

# MC44604

## High Safety Pulsed Mode Standby GreenLine™ PWM Controller

The MC44604 is an enhanced high performance controller that is specifically designed for off-line and dc-to-dc converter applications. Its high current totem pole output is ideally suited for driving a power MOSFET.

The MC44604 is an evolution of the MC44603A. Like the MC44603A, the MC44604 has been optimized to operate with universal ac mains voltage from 80 V to 280 V. It also offers enhanced safety and reliable power management thanks to its protection features (foldback, overvoltage detection, soft-start, accurate demagnetization detection).

In addition, the MC44604 offers a new efficient way to reduce the standby operating power by means of a so-called pulsed mode standby operation of the converter, significantly reducing the converter consumption in standby mode.

### Current Mode Controller

- Operation Up to 250 kHz Output Switching Frequency
- Inherent Feed Forward Compensation
- Latching PWM for Cycle-by-Cycle Current Limiting
- Oscillator with Precise Frequency Control

### High Flexibility

- Externally Programmable Reference Current
- Secondary or Primary Sensing
- High Current Totem Pole Output
- Undervoltage Lockout with Hysteresis

### Safety/Protection Features

- Overvoltage Protection Facility Against Open Loop
- Protection Against Short Circuit on Oscillator Pin
- Fully Programmable Foldback
- Soft-Start Feature
- Accurate Maximum Duty Cycle Setting
- Demagnetization (Zero Current Detection) Protection
- Internally Trimmed Reference

### GreenLine™ Controller™

- Low Startup and Operating Current
- Pulsed Mode Standby for Low Standby Losses
- Low dV/dT for Low EMI

### Features

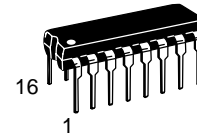
- Pb-Free Package is Available\*

\*For additional information on our Pb-Free strategy and soldering details, please download the ON Semiconductor Soldering and Mounting Techniques Reference Manual, SOLDERRM/D.



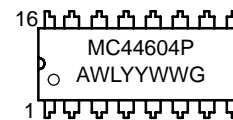
ON Semiconductor®

<http://onsemi.com>



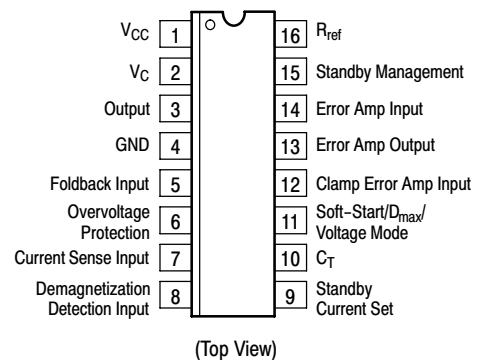
PDIP-16  
P SUFFIX  
CASE 648

### MARKING DIAGRAM



A = Assembly Location  
WL = Wafer Lot  
YY = Year  
WW = Work Week  
G = Pb-Free Package

### PIN CONNECTIONS

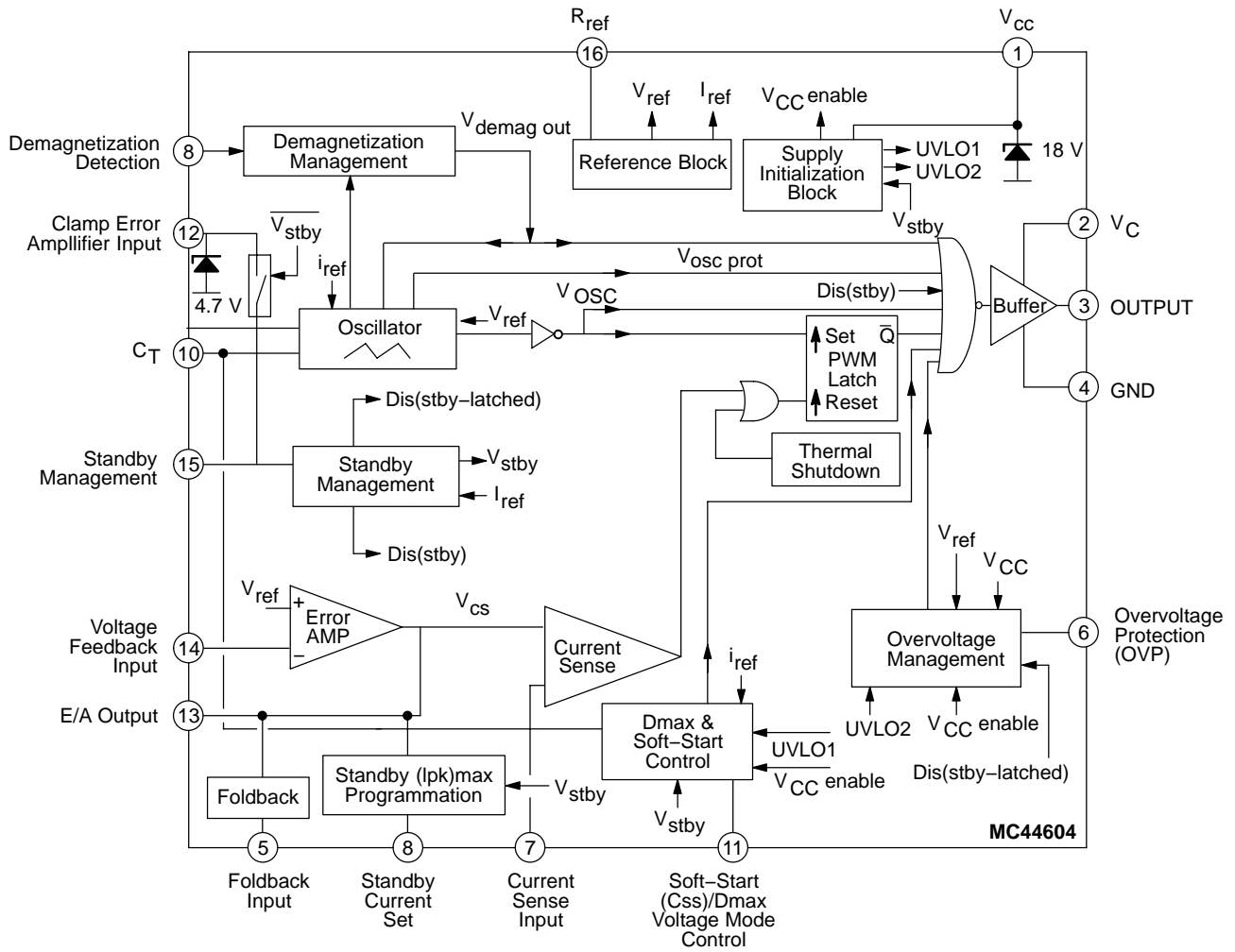


### ORDERING INFORMATION

Device	Package	Shipping
MC44604P	PDIP-16	25 Units / Rail
MC44604PG	PDIP-16 (Pb-Free)	25 Units / Rail

# MC44604

## Block Diagram



# MC44604

## MAXIMUM RATINGS

Rating	Pin #	Symbol	Value	Unit
Total Power Supply and Zener Current		$(I_{CC} + I_Z)$	30	mA
Output Supply Voltage with Respect to Ground	2 1	$V_C$ $V_{CC}$	18	V
Output Current (Note 1) – Source – Sink	3	$I_{O(\text{Source})}$ $I_{O(\text{Sink})}$	–750 750	mA
Output Energy (Capacitive Load per Cycle)		W	5.0	$\mu\text{J}$
Soft–Start	11	$V_{SS}$	–0.3 to 2.2	V
Clamp Error Amp Input	12	$V_{CLEA}$	–0.3 to 4.5	V
Foldback Input, Stand–by Management			–0.3 to $V_{CC} + 0.3$	V
Overvoltage Protection, Current Sense Input, $R_{ref}$ , Error Amp Input, Error Amp Output, $C_T$ , Stand–by Current Set		$V_{in}$	–0.3 to 5.5	V
Demagnetization Detection Input Current – Source – Sink	8	$I_{demag-ib (\text{Source})}$ $I_{demag-ib (\text{Sink})}$	–4.0 10	mA
Error Amplifier Output Sink Current	13	$I_{E/A (\text{Sink})}$	20	mA
Power Dissipation and Thermal Characteristics Maximum Power Dissipation at $T_A = 85^\circ\text{C}$ Thermal Resistance, Junction–to–Air		$P_D$ $R_{\theta JA}$	0.6 100	W $^\circ\text{C/W}$
Operating Junction Temperature		$T_J$	150	$^\circ\text{C}$
Operating Ambient Temperature		$T_A$	–25 to +85	$^\circ\text{C}$

Maximum ratings are those values beyond which device damage can occur. Maximum ratings applied to the device are individual stress limit values (not normal operating conditions) and are not valid simultaneously. If these limits are exceeded, device functional operation is not implied, damage may occur and reliability may be affected.

1. Maximum package power dissipation must be observed.

**ELECTRICAL CHARACTERISTICS** ( $V_{CC}$  and  $V_C = 12\text{ V}$  [Note 2],  $R_{ref} = 10\text{ k}\Omega$ ,  $C_T = 820\text{ pF}$ , for typical values  $T_A = 25^\circ\text{C}$ , for min/max values  $T_A = -25^\circ\text{C}$  to  $+85^\circ\text{C}$  [Note 3], unless otherwise noted.)

Characteristic	Pin #	Symbol	Min	Typ	Max	Unit
----------------	-------	--------	-----	-----	-----	------

### OUTPUT SECTION (Note 4)

Output Voltage (Note 5) Low Level Drop Voltage ( $I_{\text{Sink}} = 100\text{ mA}$ ) ( $I_{\text{Sink}} = 500\text{ mA}$ ) High Level Drop Voltage ( $I_{\text{Source}} = 200\text{ mA}$ ) ( $I_{\text{Source}} = 500\text{ mA}$ )	3	$V_{OL}$  $V_{OH}$	– – – –	1.0 1.4 1.5 2.0	1.2 2.0 2.0 2.7	V
Output Voltage During Initialization Phase $V_{CC} = 0$ to $1.0\text{ V}$ , $I_{\text{Sink}} = 10\text{ }\mu\text{A}$ $V_{CC} = 1.0$ to $5.0\text{ V}$ , $I_{\text{Sink}} = 100\text{ }\mu\text{A}$ $V_{CC} = 5.0$ to $13\text{ V}$ , $I_{\text{Sink}} = 1.0\text{ mA}$	3	$V_{OL}$	– – –	– 0.1 0.1	1.0 1.0 1.0	V
Output Voltage Rising Edge Slew–Rate ( $C_L = 1.0\text{ nF}$ , $T_J = 25^\circ\text{C}$ )	3	$dV_o/dT$	–	300	–	$\text{V}/\mu\text{s}$
Output Voltage Falling Edge Slew–Rate ( $C_L = 1.0\text{ nF}$ , $T_J = 25^\circ\text{C}$ )	3	$dV_o/dT$	–	–300	–	$\text{V}/\mu\text{s}$

### ERROR AMPLIFIER SECTION

Voltage Feedback Input ( $V_{E/A \text{ out}} = 2.5\text{ V}$ )	14	$V_{FB}$	2.4	2.5	2.6	V
Input Bias Current ( $V_{FB} = 2.5\text{ V}$ )	14	$I_{FB-ib}$	–2.0	–0.6	–	$\mu\text{A}$
Open Loop Voltage Gain ( $V_{E/A \text{ out}} = 2.0\text{ V}$ to $4.0\text{ V}$ )		$A_{VOL}$	65	70	–	dB
Unity Gain Bandwidth $T_J = 25^\circ\text{C}$ $T_A = -25^\circ\text{C}$ to $+85^\circ\text{C}$		BW	– –	– –	– 5.5	MHz
Voltage Feedback Input Line Regulation ( $V_{CC} = 10\text{ V}$ to $15\text{ V}$ )	14	$V_{FBline-reg}$	–10	–	10	mV

2. Adjust  $V_{CC}$  above the startup threshold before setting to  $12\text{ V}$ .
3. Low duty cycle pulse techniques are used during test to maintain junction temperature as close to ambient as possible.
4. No output signal when the Error Amplifier is in Low State, i.e.,  $V_{FB} = 2.7\text{ V}$ .
5.  $V_C$  must be greater than  $5.0\text{ V}$ .

# MC44604

**ELECTRICAL CHARACTERISTICS** ( $V_{CC}$  and  $V_C = 12$  V [Note 6],  $R_{ref} = 10$  k $\Omega$ ,  $C_T = 820$  pF, for typical values  $T_A = 25^\circ\text{C}$ , for min/max values  $T_A = -25^\circ$  to  $+85^\circ\text{C}$  [Note 7], unless otherwise noted.)

Characteristic	Pin #	Symbol	Min	Typ	Max	Unit
<b>ERROR AMPLIFIER SECTION (continued)</b>						
Output Current Sink ( $V_{E/A\ out} = 1.5$ V, $V_{FB} = 2.7$ V) $T_A = -25^\circ$ to $+85^\circ\text{C}$ Source ( $V_{E/A\ out} = 5.0$ V, $V_{FB} = 2.3$ V) $T_A = -25^\circ$ to $+85^\circ\text{C}$	13	$I_{Sink}$  $I_{Source}$	2.0  -2.0	12  -	-  -0.2	mA
Output Voltage Swing High State ( $I_{E/A\ out\ (source)} = 0.5$ mA, $V_{FB} = 2.3$ V) Low State ( $I_{E/A\ out\ (sink)} = 0.33$ mA, $V_{FB} = 2.7$ V)	13	$V_{OH}$ $V_{OL}$	5.5 -	6.5 1.0	7.5 1.1	V
<b>REFERENCE SECTION</b>						
Reference Output Voltage ( $V_{CC} = 10$ V to 15 V)	16	$V_{ref}$	2.4	2.5	2.6	V
Reference Current Range ( $I_{ref} = V_{ref}/R_{ref}$ , $R = 5.0$ k to 25 k $\Omega$ )	16	$I_{ref}$	-500	-	-100	$\mu\text{A}$
Reference Voltage Over $I_{ref}$ Range		$\Delta V_{ref}$	-40	-	40	mV
<b>OSCILLATOR SECTION</b>						
Frequency $T_A = 0^\circ$ to $+70^\circ\text{C}$ $T_A = -25^\circ$ to $+85^\circ\text{C}$		$F_{OSC}$	40.5 40	46 -	48.5 49	kHz
Frequency Change with Voltage ( $V_{CC} = 10$ V to 15 V)		$\Delta F_{OSC}/\Delta V$	-	0.05	-	%/V
Frequency Change with Temperature ( $T_A = -25^\circ$ to $+85^\circ\text{C}$ )		$\Delta F_{OSC}/\Delta T$	-	0.05	-	%/ $^\circ\text{C}$
Oscillator Voltage Swing (Peak-to-Peak)	10	$V_{OSC(P-P)}$	-	2.0	-	V
Ratio Charge Current/Reference Current ( $T_A = -25^\circ$ to $+85^\circ\text{C}$ )		$I_{charge}/I_{ref}$	0.35	-	0.43	-
Fixed Maximum Duty Cycle = $I_{discharge}/(I_{discharge} + I_{charge})$		D	78	80	82	%
<b>UNDERVOLTAGE LOCKOUT SECTION</b>						
Startup Threshold	1	$V_{stupa-th}$	13.6	14.5	15.4	V
Disable Voltage After Threshold Turn-On $T_A = 0^\circ$ to $+70^\circ\text{C}$ $T_A = -25^\circ$ to $+85^\circ\text{C}$	1	$V_{disable1}$	8.6 8.3	9.0 -	9.4 9.6	V
Disable Voltage After Threshold Turn-On	1	$V_{disable2}$	7.0	7.5	8.0	V
Delta $V_{CC}$ During Standby ( $V_{stupa-th} - V_{disable2}$ ) ( $T_A = -25^\circ\text{C}$ to $85^\circ\text{C}$ )	1	$V_{stupa-th} - V_{disable2}$	1.8	2.0	2.2	V
<b>DEMAGNETIZATION DETECTION SECTION</b>						
Demagnetization Detect Input Demagnetization Comparator Threshold ( $V_{pin8}$ Decreasing) Propagation Delay (Input to Output, Low to High) Input Bias Current ( $V_{demag} = 65$ mV)	8	$V_{demag-th}$ - $I_{demag-lb}$	50 - -0.5	65 0.25 -	80 - -	mV $\mu\text{s}$ $\mu\text{A}$
Negative Clamp Level ( $I_{demag} = -2.0$ mA)		$C_{L(neg)}$	-	-0.38	-	V
Positive Clamp Level ( $I_{demag} = +2.0$ mA)		$C_{L(pos)}$	-	0.72	-	V
<b>SOFT-START SECTION</b>						
Ratio Charge Current/ $I_{ref}$ $T_A = 0^\circ$ to $+70^\circ\text{C}$ $T_A = -25^\circ$ to $+85^\circ\text{C}$		$I_{ss(ch)}/I_{ref}$	0.37 0.36	0.4 -	0.43 0.44	-
Discharge Current ( $V_{soft-start} = 1.0$ V)	11	$I_{discharge}$	1.5	5.0	-	mA
Clamp Level		$V_{ss(CL)}$	2.2	2.4	2.6	V
Duty Cycle ( $R_{soft-start} = 12$ k $\Omega$ ) ( $V_{soft-start}$ (pin11) = 0.1 V)		$D_{soft-start\ 12k}$ $D_{soft-start}$	36 -	42 -	49 0	%

6. Adjust  $V_{CC}$  above the startup threshold before setting to 12 V.

7. Low duty cycle pulse techniques are used during test to maintain junction temperature as close to ambient as possible.

# MC44604

**ELECTRICAL CHARACTERISTICS** ( $V_{CC}$  and  $V_C = 12$  V [Note 8],  $R_{ref} = 10$  k $\Omega$ ,  $C_T = 820$  pF, for typical values  $T_A = 25^\circ\text{C}$ , for min/max values  $T_A = -25^\circ$  to  $+85^\circ\text{C}$  [Note 9], unless otherwise noted.)

Characteristic	Pin #	Symbol	Min	Typ	Max	Unit
<b>CURRENT SENSE SECTION</b>						
Maximum Current Sense Input Threshold ( $V_{Feedback}$ (pin14) = 2.3 V and $V_{foldback}$ (pin6) = 1.2 V)	7	$V_{CS-th}$	0.93	0.96	1.00	V
Input Bias Current	7	$I_{CS-ib}$	-10	-2.0	-	$\mu\text{A}$
Propagation Delay (Note 10) in Normal Mode in Standby Mode		$t_{CS-NM}$	-	120	200	ns
		$t_{CS-stby}$	-	120	200	
<b>OVERVOLTAGE SECTION</b>						
Protection Threshold Level on $V_{OVP}$	6	$V_{OVP-th}$	2.42	2.5	2.58	V
Propagation Delay ( $V_{OVP} > 2.58$ V to $V_{out}$ Low)			1.0	-	3.0	$\mu\text{s}$
Protection Level on $V_{CC}$ $T_A = 0^\circ$ to $+70^\circ\text{C}$ $T_A = -25^\circ$ to $+85^\circ\text{C}$		$V_{CC\ prot}$	16.1	17	17.9	V
			15.9	-	18.1	
Input Resistance $T_A = 0^\circ$ to $+70^\circ\text{C}$ $T_A = -25^\circ$ to $+85^\circ\text{C}$		-	1.5	2.0	3.0	k $\Omega$
			1.4	-	3.4	
<b>FOLDBACK SECTION (Note 11)</b>						
Current Sense Voltage Threshold ( $V_{foldback}$ (pin5) = 0.9 V)	5	$V_{CS-th}$	0.84	0.88	0.89	V
Foldback Input Bias Current ( $V_{foldback}$ (pin5) = 0 V)	5	$I_{foldback-lb}$	-6.0	-2.0	-	$\mu\text{A}$
<b>CLAMP ERROR AMPLIFIER INPUT</b>						
Clamp Level (@ $I = 30$ mA)	12	$V_{cl}$	4.5	4.7	4.9	V
<b>STANDBY PULSED MODE SECTION</b>						
Standby Initialization Current Ratio (S1 closed)	15	$I_{init}/I_{ref}$	126	140	154	-
Minimum Initialization Current Pulse Width (Note 12)		$T_{init}$	-	-	1.0	$\mu\text{s}$
Standby On Detection Current Ratio	15	$I_{det}/I_{ref}$	0.34	0.38	0.42	-
Standby Regulation Current Ratio	15	$I_{reg}/I_{ref}$	18	20.5	23	-
Standby Bias Current (S1 and S2 open; $0$ V < $V_{pin15}$ < $V_{stup-th}$ ) (Note 13)	15	$I_{stby-ib}$	-1.0	-	2.0	$\mu\text{A}$
<b>STANDBY CURRENT SET</b>						
Peak Standby Current Setting Ratio $T_A = 0^\circ$ to $+70^\circ\text{C}$ $T_A = -25^\circ$ to $+85^\circ\text{C}$	9	$I_{pk-stby}/I_{ref}$ -	0.37	0.4	0.43	-
			0.36	0.4	0.44	
Standby Current Sense Threshold Ratio (Note 14)	7	$V_{pin9}/V_{CS-st}$	2.4	2.6	2.9	-
<b>TOTAL DEVICE</b>						
Power Supply Current Startup (Note 13) Operating $T_A = -25^\circ$ to $+85^\circ\text{C}$ (Note 9)		$I_{CC}$	-	0.3	0.45	mA
			16	20	24	
Power Supply Zener Voltage ( $I_{CC} = 25$ mA)		$V_Z$	18.5	-	-	V
Thermal Shutdown		-	-	155	-	$^\circ\text{C}$

8. Adjust  $V_{CC}$  above the startup threshold before setting to 12 V.

9. Low duty cycle pulse techniques are used during test to maintain junction temperature as close to ambient as possible.

10. Current Sense Input to Output at  $V_{TH}$  of MOS transistor = 3.0 V.

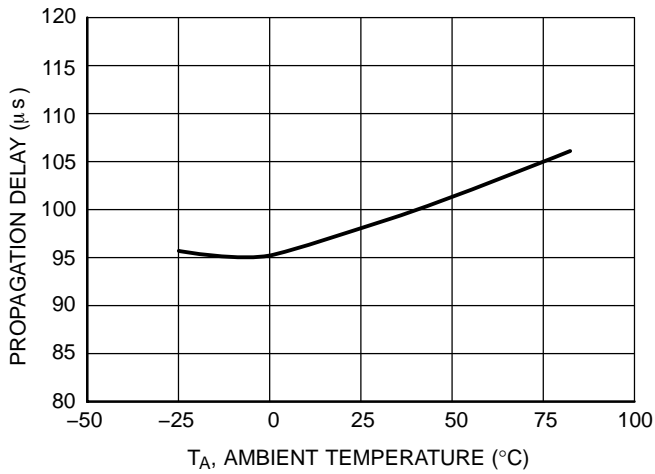
11. This function can be inhibited by connecting pin 5 to  $V_{CC}$ .

12. This is the minimum time during which the pin 15 current must be higher than  $I_{init}$  to enable the detection of the transition normal to standby mode.

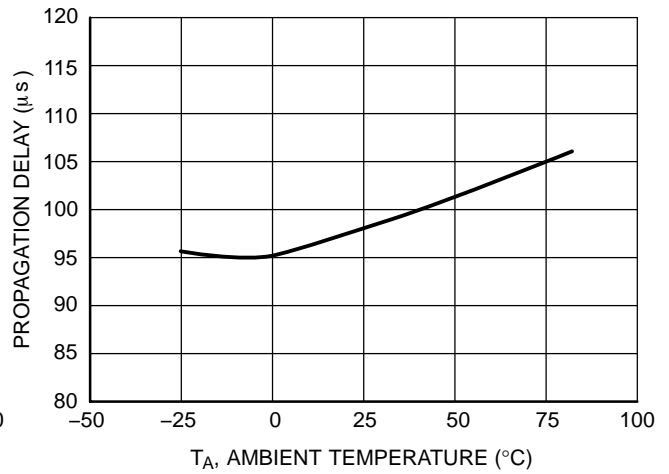
13. Tested using  $V_{CC} = 6.0$  V, 9.0 V, 13.5 V, the MC44604 being off.

14. Tested using  $V_{pin9} = 0.2$  V, 0.4 V, 0.6 V, 0.8 V, 1.0 V.

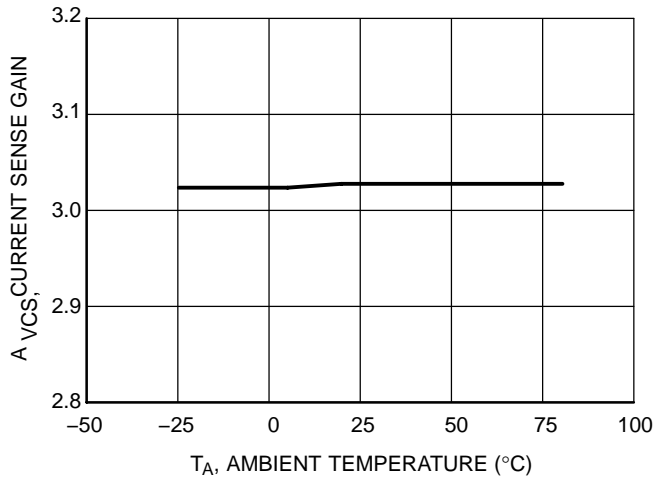
# MC44604



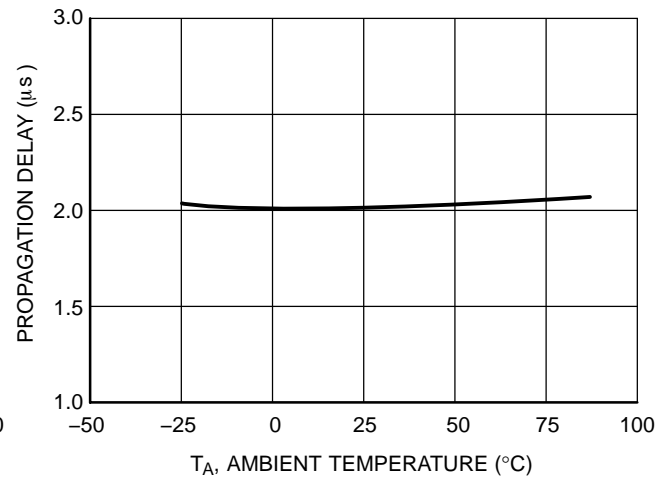
**Figure 1. Propagation Delay Current Sense Input vs. Temperature**



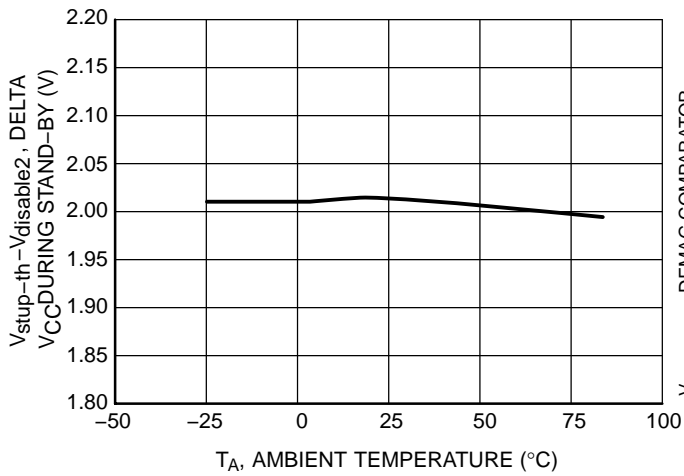
**Figure 2. Propagation Delay Current Sense Input in Standby vs. Temperature**



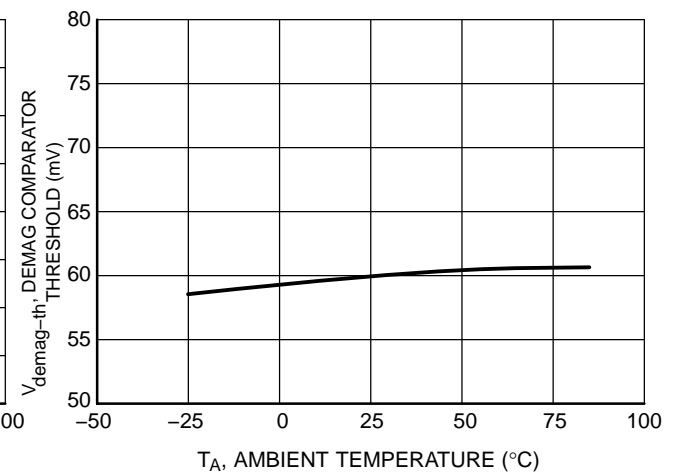
**Figure 3. Current Sense Gain vs. Temperature**



**Figure 4. Propagation Delay Current (V<sub>otp</sub> > 2.58 V to V<sub>out</sub> Low) vs. Temperature**

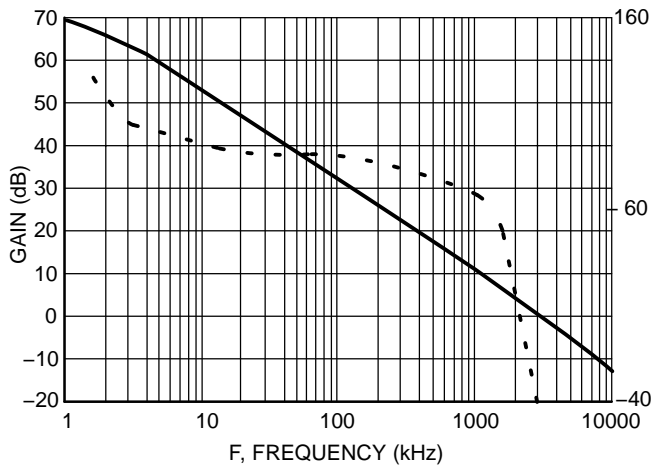


**Figure 5. Delta V<sub>CC</sub> During Standby**

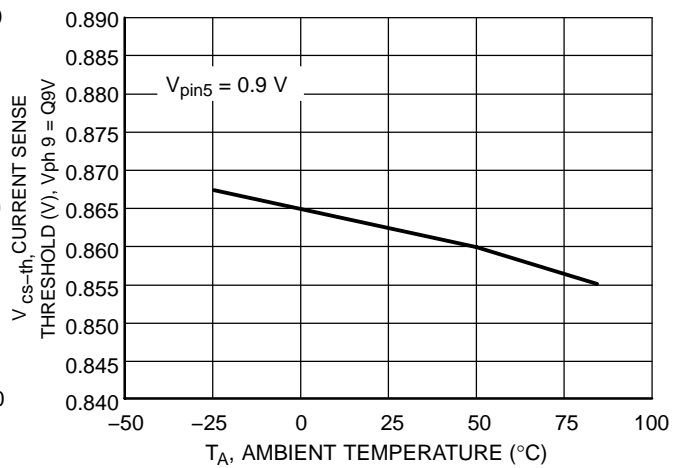


**Figure 6. Demag Comparator Threshold vs. Temperature**

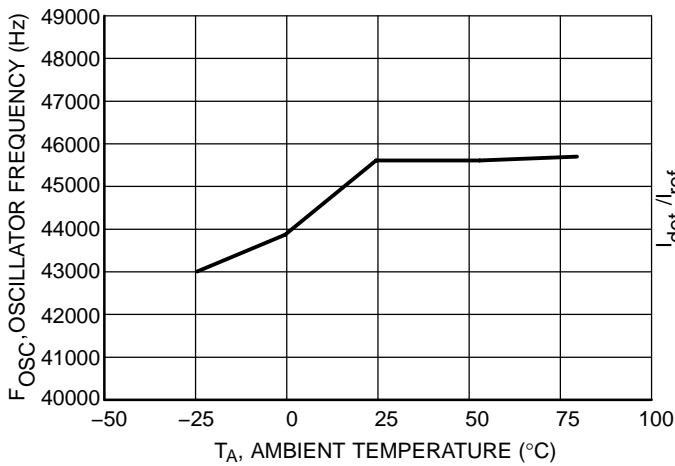
# MC44604



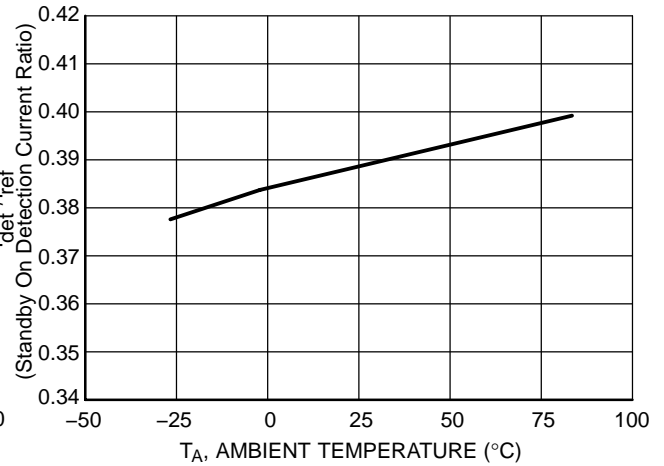
**Figure 7. Error Amplifier Gain and Phase vs. Frequency**



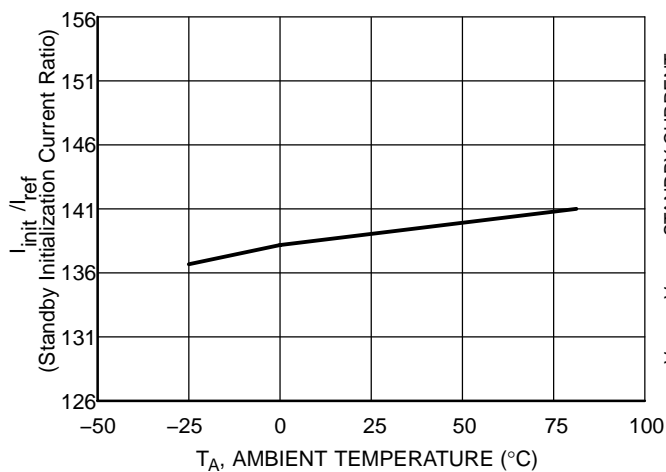
**Figure 8. Current Sense Voltage Threshold vs. Temperature**



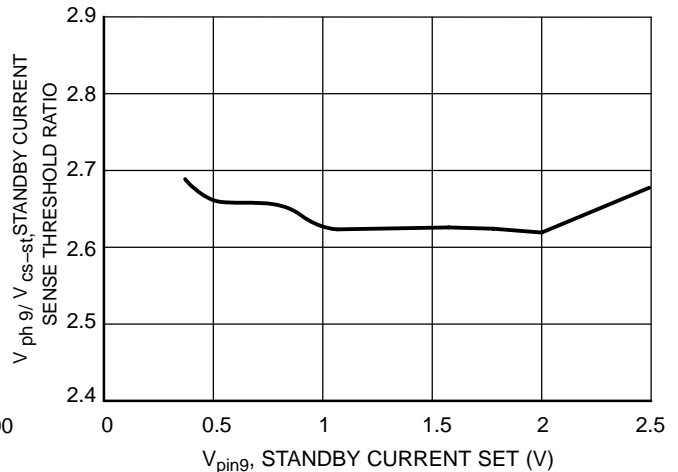
**Figure 9. Oscillator Frequency vs. Temperature**



**Figure 10. Standby On Detection Current Ratio vs. Temperature**



**Figure 11. Standby Initialization Current Ratio vs. Temperature**



**Figure 12. Standby Current Sense Threshold Ratio**

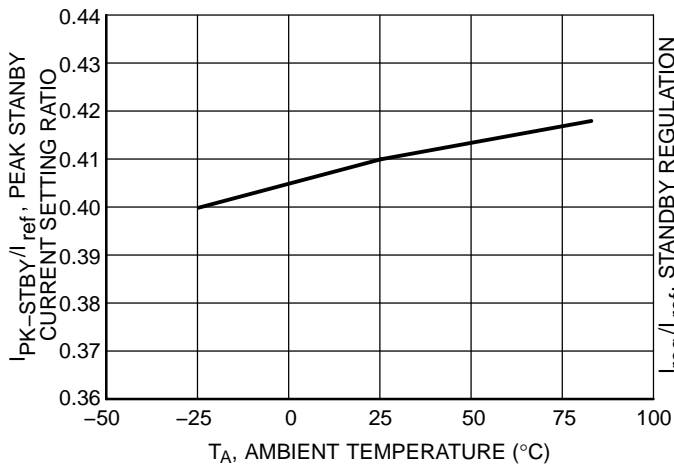


Figure 13. Peak Standby Current Setting Ratio vs. Temperature

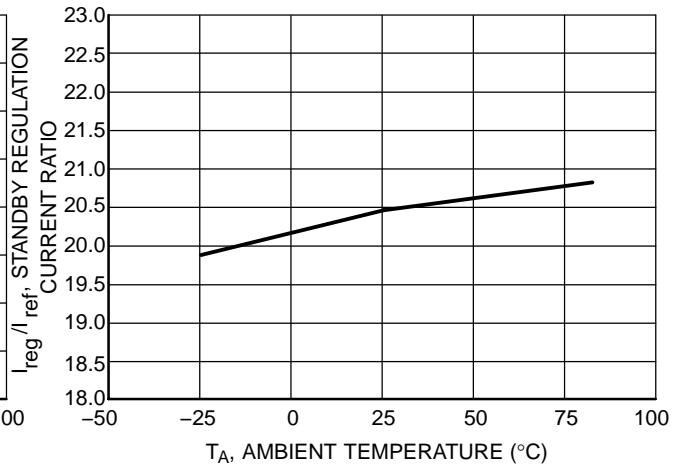


Figure 14. Standby Regulation Current Ratio vs. Temperature

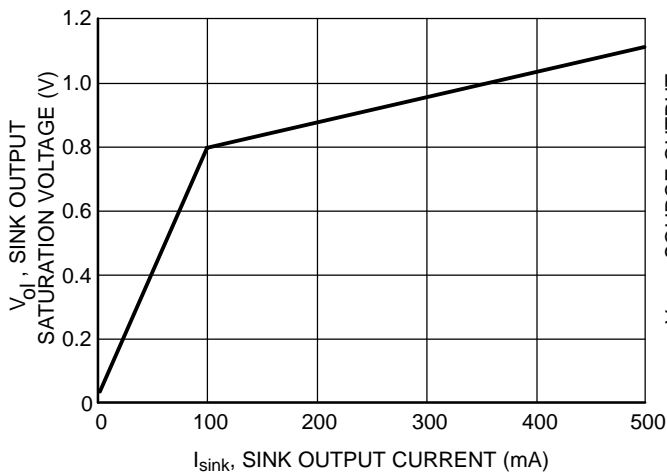


Figure 15. Sink Output Saturation Voltage vs. Sink Current

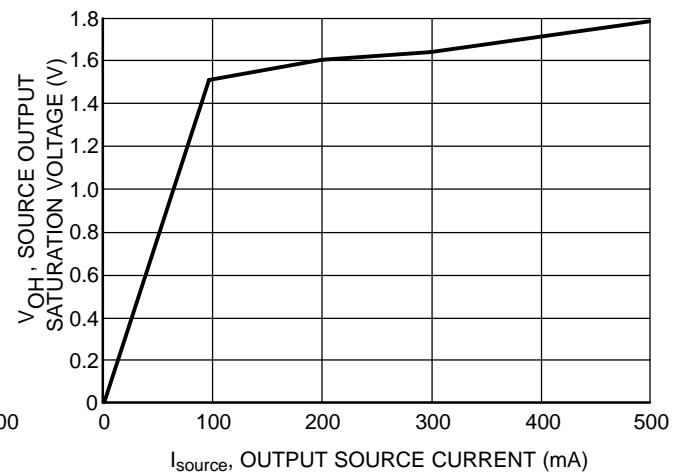


Figure 16. Source Output Saturation Voltage vs. Source Current

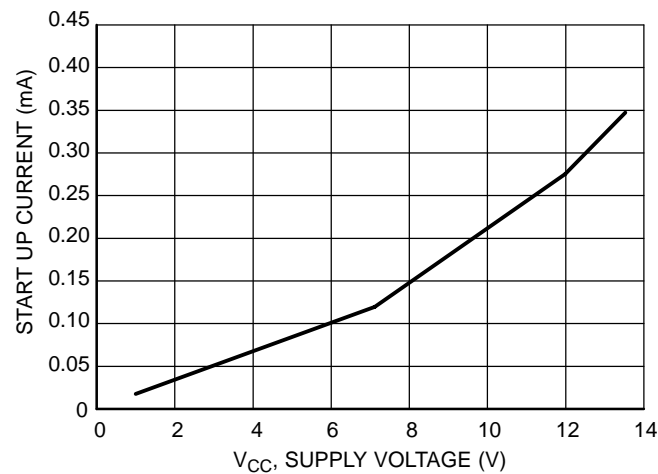


Figure 17. Startup Current vs.  $V_{CC}$

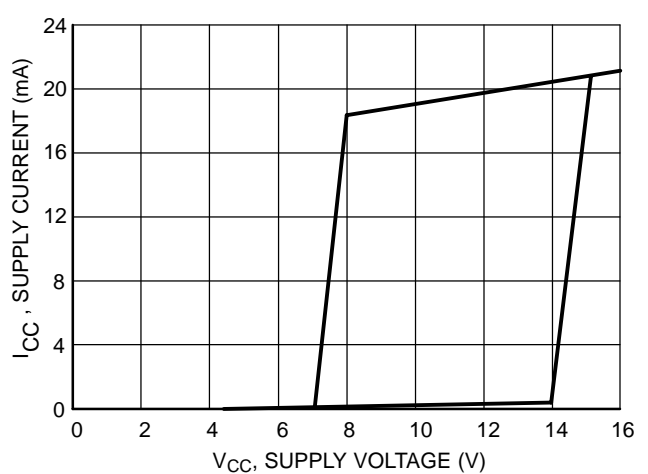
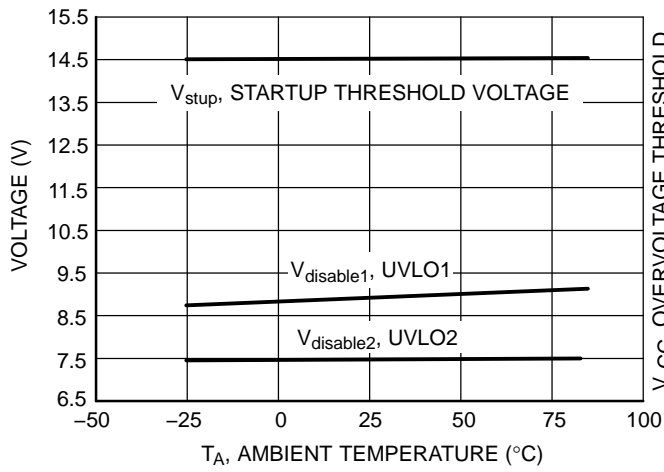


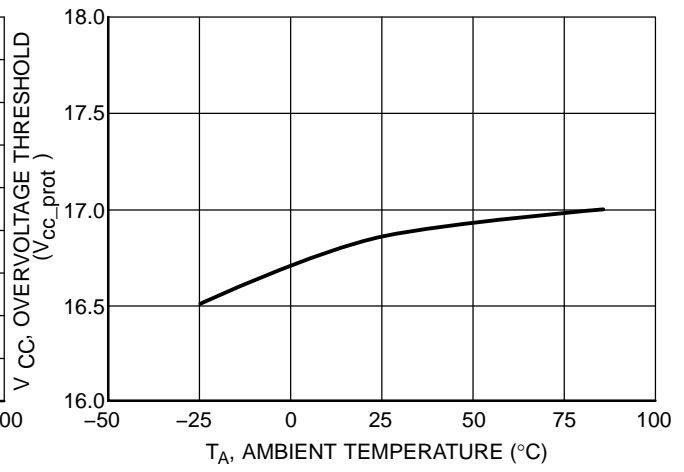
Figure 18. Supply Current vs. Supply Voltage



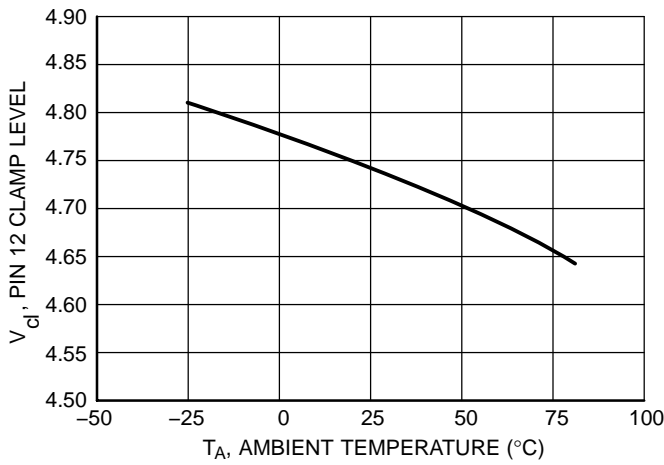
# MC44604



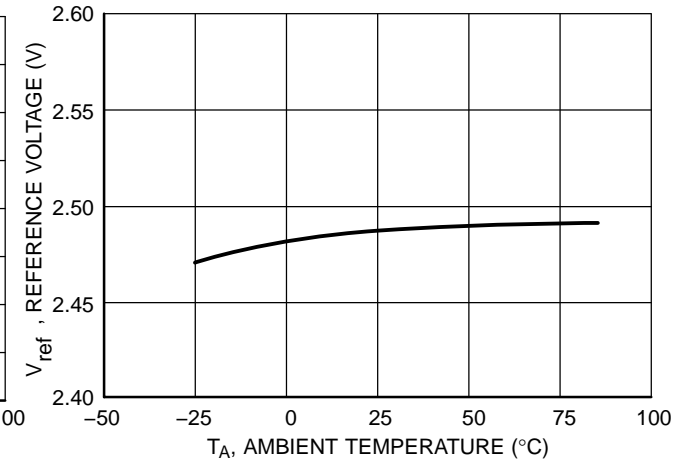
**Figure 19. Startup Threshold, UVLO1, UVLO2 Voltage vs. Temperature**



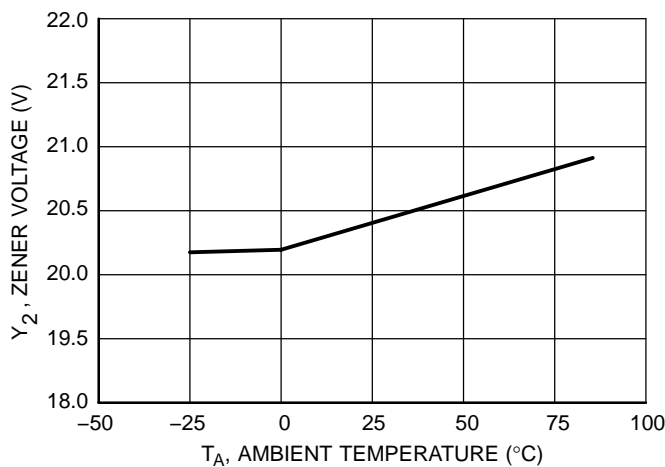
**Figure 20. Protection Level on V<sub>CC</sub> vs. Temperature**



**Figure 21. Clamp Error Amplifier Input vs. Temperature**



**Figure 22. Reference Voltage vs. Temperature**



**Figure 23. Power Supply Zener Voltage vs. Temperature**

## MC44604

Pin	Name	Pin Description
1	V <sub>CC</sub>	This pin is the positive supply of the IC.
2	V <sub>C</sub>	The output high state, V <sub>OH</sub> , is set by the voltage applied to this pin. With a separate connection to the power source, it gives the possibility to set by means of an external resistor the output source current at a different value than the sink current.
3	Output	The output current capability is suited for driving a power MOSFET. A Bipolar transistor can also be driven for low power applications. The maximum on-time of the duty cycle can last up to 80% of the switching period.
4	GND	The ground pin is a single return typically connected back to the power source, it is used as control and power ground.
5	Foldback Input	The foldback function ensures an overload protection. Feeding the foldback input with a portion of the V <sub>CC</sub> voltage (1.0 V max) establishes on the system control loop a foldback characteristic allowing a smoother startup and a sharper overload protection. The foldback action performs an active current sense clamping reduction. Above 1.0 V the foldback input is no more active.
6	Overvoltage Protection	When the overvoltage protection pin receives a voltage greater than 17 V the device gets disabled and requires a complete restart sequence. The overvoltage level is programmable.
7	Current Sense Input	A voltage proportional to the current flowing into the power switch is connected to this input. The PWM latch uses this information to terminate the conduction of the output buffer when operating in current mode. A maximum level of 1.0 V allows to limit the inductor current either in current or voltage mode of operation.
8	Demagnetization Detection	A voltage delivered by an auxiliary transformer winding provides to the demagnetization pin an indication of the magnetization state of the flyback energy reservoir. A zero voltage detection corresponds to a complete core demagnetization. The demagnetization detection ensures a discontinuous mode of operation. This function can be inhibited by connecting Pin 8 to GND.
9	Standby Current Set	Using an external resistor connected to this pin, the standby burst mode peak current can be adjusted.
10	C <sub>T</sub>	The normal mode oscillator frequency is programmed by the capacitor C <sub>T</sub> choice together with the R <sub>ref</sub> resistance value. C <sub>T</sub> , connected between pin 10 and GND, generates the oscillator sawtooth.
11	Soft-Start/D <sub>max</sub> /Voltage-Mode	A capacitor or a resistor or a voltage source connected to this pin can temporary or permanently control the effective switching duty-cycle. This pin can be used as a voltage mode control input. By connecting pin 11 to Ground, the MC44604 can be shut down.
12	Clamp Error Amplifier Input	In normal mode, the current drawn from this pin, is used by the Error Amplifier to perform the regulation. A 4.7 V zener diode clamps the voltage of this pin.
13	E/A Out	The error amplifier output is made available for loop compensation.
14	Voltage Feedback	This is the inverting input of the Error Amplifier. It uses a voltage that is built up using the current drawn from the pin 12.
15	Standby Management	This block is designed to detect the standby mode. It particularly determines if the circuit must work in standby or in normal mode at each startup. For that, it uses an information given by an external arrangement consisting of an opto-coupler. In standby mode, this block makes the circuit work in the standby configuration, and the current injected in the pin 15 is used to perform the regulation. In normal mode, this pin is internally connected to the pin 12.
16	R <sub>REF</sub>	The R <sub>REF</sub> values fixes the internal reference current which is used to perform the precise oscillator waveform. The current range goes from 100 μA up to 500 μA.

# MC44604

## Operating Description Schematics

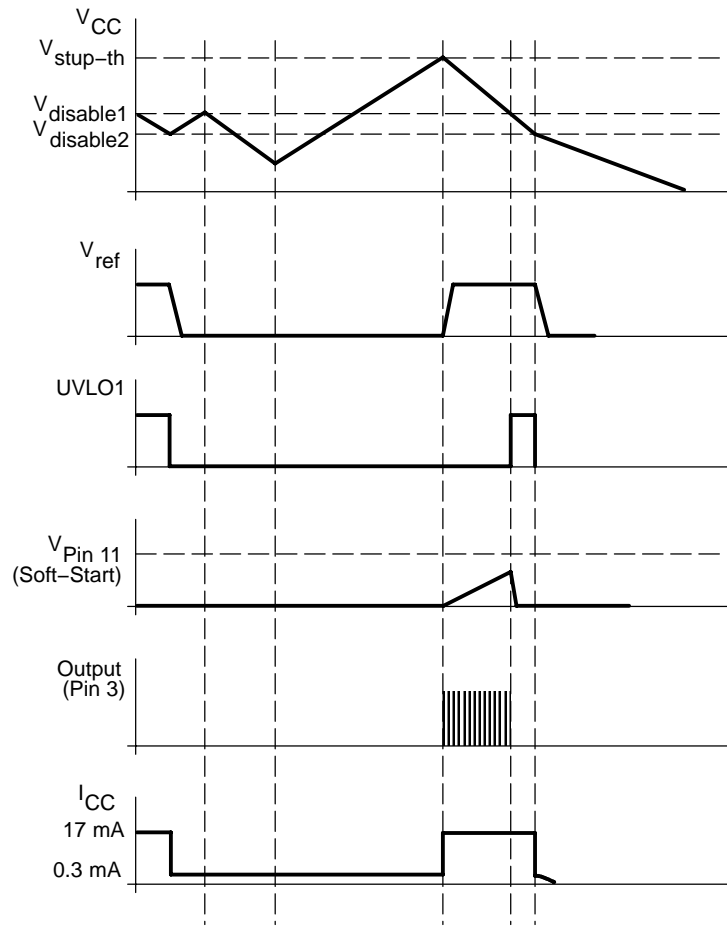


Figure 24. Switching Off Behavior

Operating Description Schematics

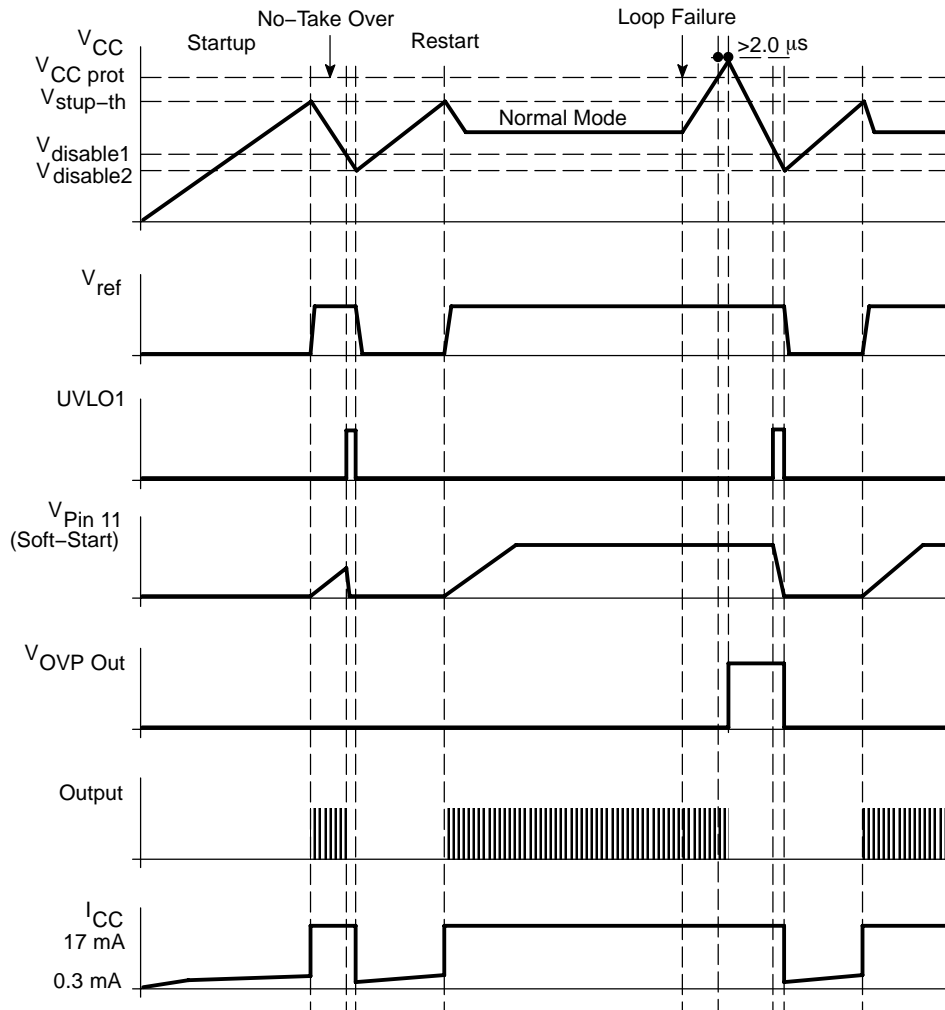


Figure 25. Starting Behavior and Overvoltage

Operating Description Schematics

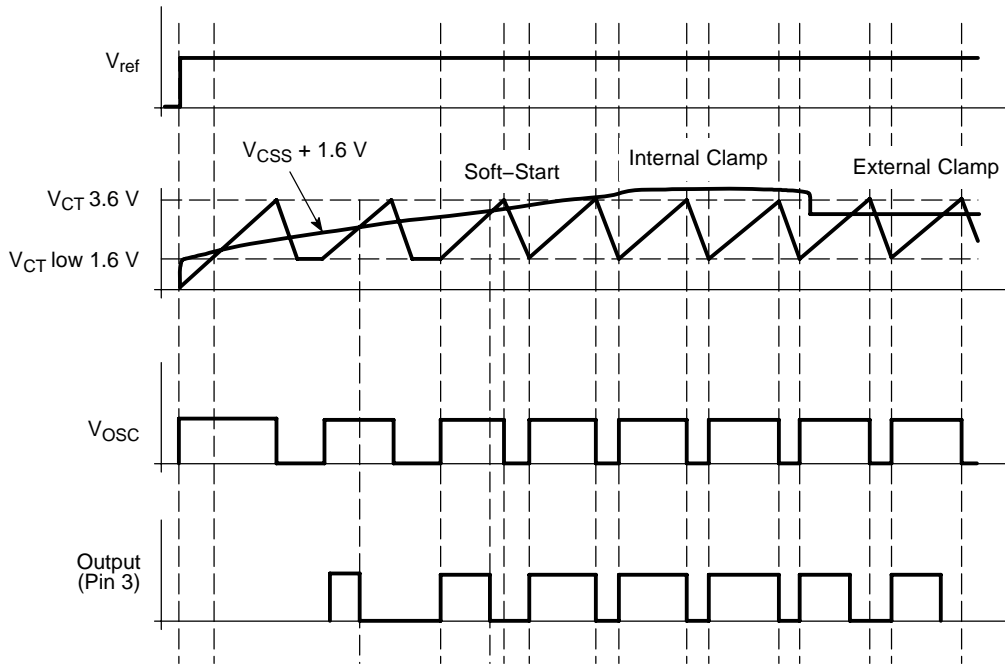


Figure 26. Soft-Start and  $D_{max}$

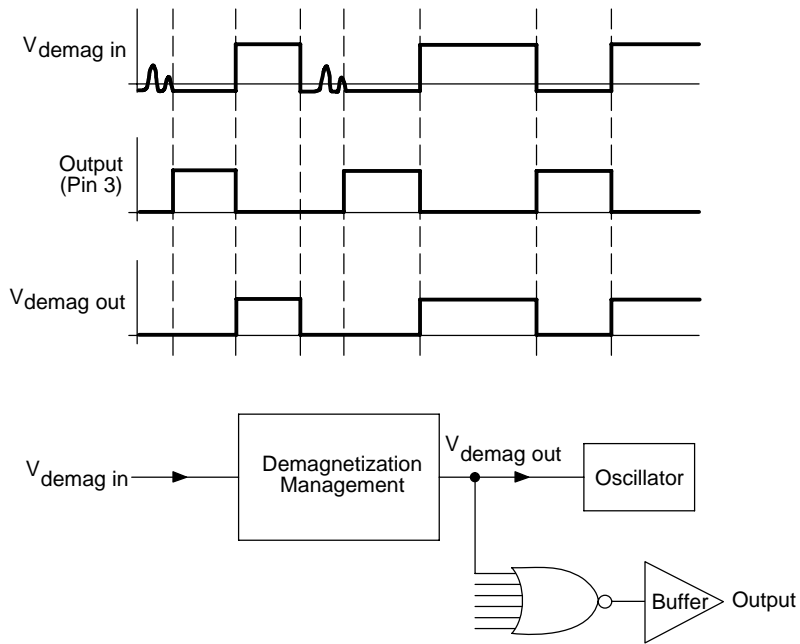


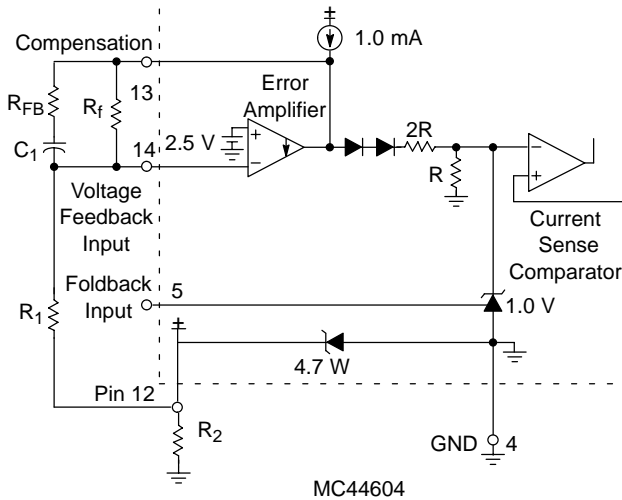
Figure 27. Demagnetization

**Error Amplifier**

A fully compensated Error Amplifier with access to the inverting input and output is provided. It features a typical DC voltage gain of 70 dB. The non-inverting input is internally biased at 2.5 V and is not pinned out. The converter output voltage is typically divided down and monitored by the inverting input. The maximum input bias current with the inverting input at 2.5 V is  $-2.0 \mu\text{A}$ . This can cause an output voltage error that is equal to the product of the input bias current and the equivalent input divider source resistance.

The Error Amp Output (Pin 13) is provided for external loop compensation. The output voltage is offset by two diodes drops ( $\approx 1.4 \text{ V}$ ) and divided by three before it connects to the inverting input of the Current Sense Comparator. This guarantees that no drive pulses appear at the Source Output (Pin 3) when Pin 13 is at its lowest state ( $V_{OL}$ ). This occurs when the power supply is operating and the load is removed, or at the beginning of a soft-start interval. The Error Amp minimum feedback resistance is limited by the amplifier's minimum source current (0.2 mA) and the required output voltage ( $V_{OH}$ ) to reach the current sense comparator's 1.0 V clamp level:

$$R_f(\text{min}) \approx \frac{3 \cdot 0(1.0 \text{ V}) + 1.4 \text{ V}}{0.2 \text{ mA}} = 22 \text{ k}\Omega$$



**Figure 28. Error Amplifier Compensation**

In a preferred embodiment, the feedback signal (current) is drawn from the pin 12 that is connected to the pin 15 in normal mode (Note 1). Using a resistor connected on pin 12, this current generates a voltage that is the input signal of the error amplifier arrangement.

Note 1. The error amplifier is not used in the standby mode regulation.

**Current Sense Comparator and PWM Latch**

The MC44604 can operate as a current mode controller and/or as a voltage mode controller. In current mode operation, the MC44604 uses the current sense comparator, where the output switch conduction is initiated by the oscillator and terminated when the peak inductor current reaches the threshold level established by the Error Amplifier output (Pin 13). Thus the error signal controls the peak inductor current on a cycle-by-cycle basis. The Current Sense Comparator PWM Latch configuration used ensures that only a single pulse appears at the Source Output during the appropriate oscillator cycle.

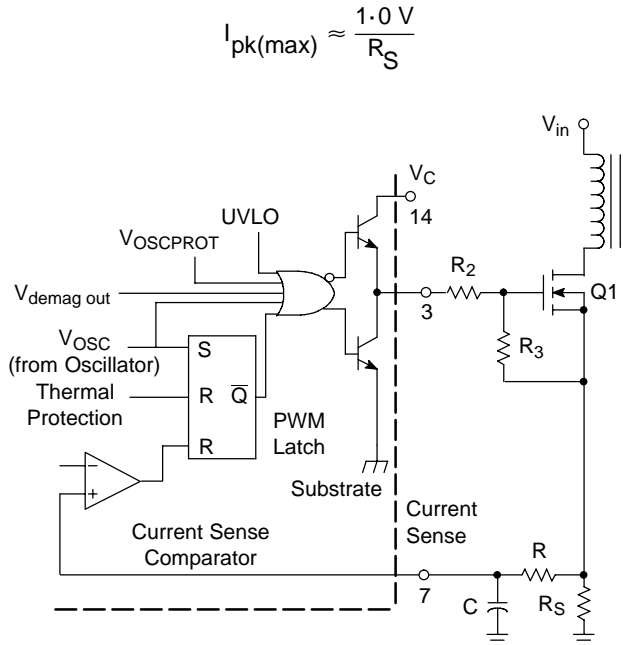
The inductor current is converted to a voltage by inserting the ground referenced sense resistor  $R_S$  in series with the power switch Q1.

In normal mode, this voltage is monitored by the Current Sense Input (Pin 7) and compared to a level derived from the Error Amp output. The peak inductor current under normal operating conditions is controlled by the voltage at Pin 13 where:

$$I_{pk} \approx \frac{V_{(\text{pin}13)} - 1.4 \text{ V}}{3 R_S}$$

The Current Sense Comparator threshold is internally clamped to 1.0 V. Therefore the maximum peak switch current is:

$$I_{pk(\text{max})} \approx \frac{1.0 \text{ V}}{R_S}$$



**Figure 29. Output Totem Pole**

**Oscillator**

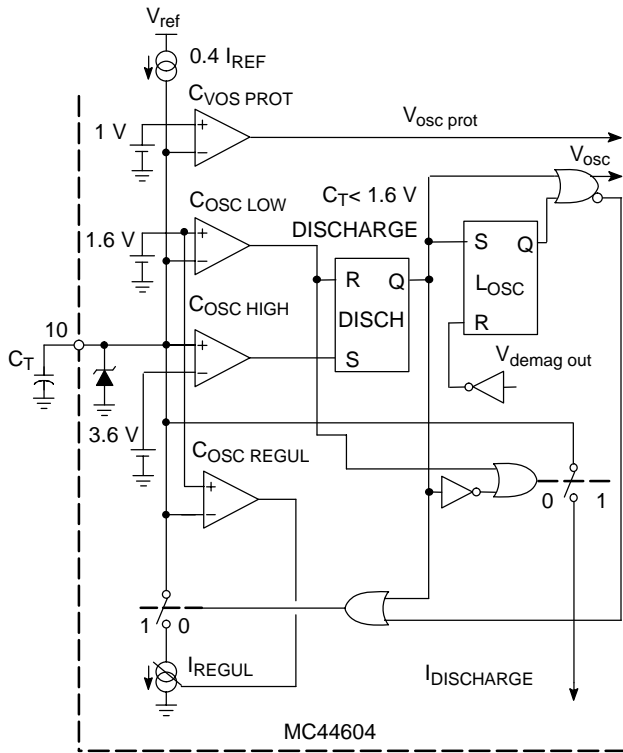
The oscillator is a very accurate sawtooth generator.

**The Sawtooth Generation**

In the steady state, the oscillator voltage varies between about 1.6 V and 3.6 V.

Indeed, the sawtooth is obtained by charging and discharging an external capacitor  $C_T$  (Pin 10), using two distinct current sources =  $I_{charge}$  and  $I_{discharge}$ . In fact,  $C_T$  is permanently connected to the charging current source ( $0.4 I_{ref}$ ) and so, the discharge current source has to be higher than the charge one to be able to decrease the  $C_T$  voltage. This condition is performed, its value being ( $2 I_{ref}$ ).

Two comparators are used to generate the sawtooth. They compare the  $C_T$  voltage to the oscillator valley and peak values. The comparison to the low value enables to detect the end of the discharge phase while the comparison to the high value determines when the charge cycle must be stopped. A latch ( $L_{DISCH}$ ) memorizes the oscillator state.



**Figure 30. Oscillator**

Now, in addition to the charge and discharge cycles, a third state can exist. This phase can be produced when at the end of the discharge phase, the oscillator has to wait for a demagnetization pulse before re-starting. During this delay, the  $C_T$  voltage must remain equal to the oscillator valley value ( $\sim 1.6$  V). So, a third regulated current source  $I_{REGUL}$  controlled by  $COSC\_REGUL$ , is connected to  $C_T$  in

order to perfectly compensate the ( $0.4 I_{ref}$ ) current source that permanently supplies  $C_T$ .

On-time is only allowed during the oscillator capacitor charge. So, the maximum duty cycle is 80%. (Note 1)

The demagnetization condition is taken into account by a second latch ( $L_{osc}$ ). (Refer to demagnetization § for further details.)

**Oscillator Frequency**

The oscillator frequency can be deduced using the following equations:

$$T_{charge} = C_T \cdot \Delta V / I_{charge}$$

$$T_{discharge} = C_T \cdot \Delta V / I_{discharge}$$

where:

$T_{charge}$  is the oscillator charge time

$\Delta V$  is the oscillator peak to peak value

$I_{charge}$  is the oscillator charge current

and

$T_{discharge}$  is the oscillator discharge time

$I_{discharge}$  is the oscillator discharge current

So, as:

$f_{osc} = 1 / (T_{charge} + T_{discharge})$  if the REGUL arrangement is not activated, the following equation can be obtained:

$$f_{osc} \sim \frac{0.395}{R_{ref} \cdot C_T}$$

**Demagnetization Block (Note 2)**

To enable the output, the  $L_{osc}$  latch complementary output must be low. Now, this latch reset is activated by the  $L_{DISCH}$  output during the discharge phase. So, to restart, the  $L_{osc}$  has to be set (refer to Figure 30). To perform this, the demagnetization signal must be low.

In a fly-back, a good means to detect the demagnetization consists in using the  $V_{CC}$  winding voltage. Indeed this voltage is:

- negative during the on-time,
- positive during the off-time,
- equal to zero for the dead-time with generally a ringing (refer to Figure 31).

That is why, the MC44604 demagnetization detection consists of a comparator that can compare the  $V_{CC}$  winding voltage to a reference that is typically equal to 65 mV.

Note 1. The output is disabled by the signal  $V_{osc\_prot}$  when  $V_{CT}$  is lower than 1 V. (Refer to Figure 29 and Figure 30.)

Note 2. The demagnetization detection can be inhibited by connecting pin 8 to the ground.

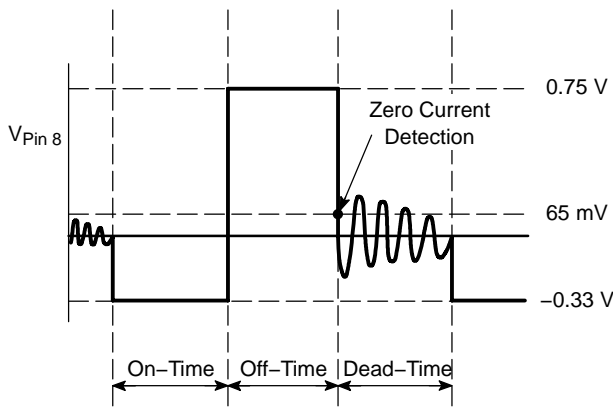


Figure 31. Demagnetization Detection

A diode D has been incorporated to clamp the positive applied voltages while an active clamping system limits the negative voltages to typically  $-0.33\text{ V}$ . This negative clamp level is sufficient to avoid the substrate diode switching on.

In addition to the comparator, a latch system has been incorporated in order to keep the demagnetization block output level low as soon as a voltage lower than  $65\text{ mV}$  is detected and as long as a new restart is produced (high level on the output) (refer to Figure 33). This process avoids that any ringing on the signal used on the pin 8, disrupts the demagnetization detection. Finally, this method results in a very accurate demagnetization detection.

For a higher safety, the demagnetization block output is also directly connected to the output, disabling it during the demagnetization phase (refer to Figure 29).

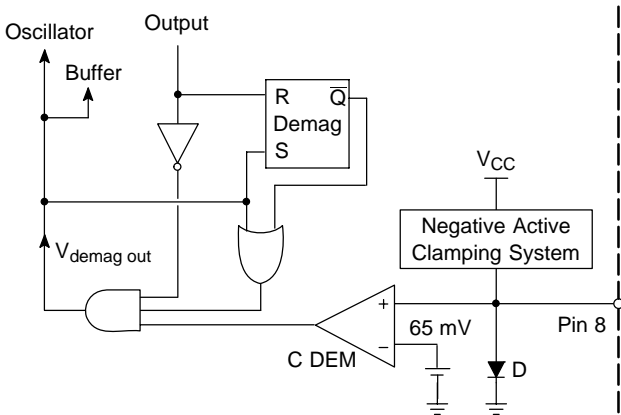


Figure 32. Demagnetization Block

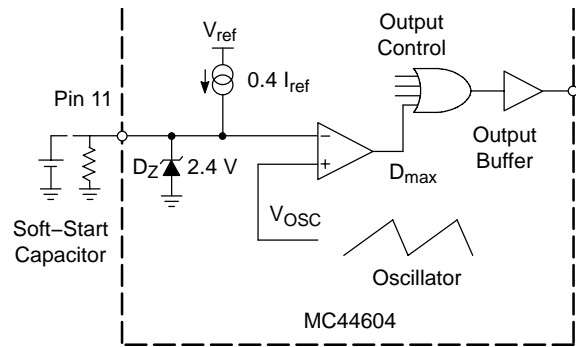


Figure 33.  $D_{max}$  and Soft-Start Block Diagram

### Maximum Duty Cycle and Soft-Start Control

As explained in the paragraph “oscillator”, the duty cycle cannot be more than 80%. Now, using the  $D_{max}$  and soft-start control, this duty cycle can be limited to a lower value. Indeed as depicted in Figure 34, the pin 11 voltage is compared to the oscillator sawtooth, so that the MC44604 output should be disabled as soon as the pin 11 level becomes lower than the oscillator voltage (refer to Figure 27 and to Figure 25).

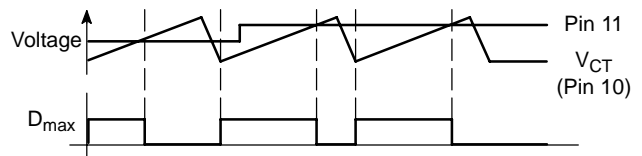


Figure 34. Maximum Duty Cycle Control

Now, using the internal current source ( $0,4 I_{ref}$ ), the pin 11 voltage can easily be fixed by connecting a resistor to this pin.

If a capacitor is connected to pin 11 (without any resistor or in parallel to a resistor for instance), the pin 11 voltage increases from 0 to its maximum value progressively (refer to Figure 26).

Thus, the allowed maximum duty cycle grows for a delay depending on the capacitor value (and the resistor value when a resistor is connected).

So, this pin can be used to limit the duty cycle during the startup phase and thus, to perform a soft-start.



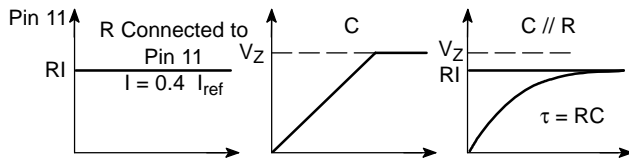


Figure 35. Different Possible Uses of Pin 11

In any case (particularly if no external component is connected to pin 11), an internal zener diode ( $D_Z$ , refer to Figure 34) is able to clamp the pin 11 voltage to a value  $V_Z$  that is higher than the oscillator value and so, that results in no max duty cycle limitation.

As soon as  $V_{disable1}$  is detected, a signal UVLO1 is generated until the  $V_{CC}$  voltage falls down to  $V_{disable2}$  (refer to the undervoltage lockout section paragraph). During the delay between the disable 1 and the disable 2, using a transistor controlled by UVLO1, the pin 11 voltage is made equal to zero in order to make the max duty cycle and soft-start arrangement ready to work for the next restart.

In standby mode, this block is inhibited in order not to interfere with the Standby Current Set.

**Protection**

The MC44604 can ensure a high converter reliability thanks to the protection it offers.

**Demagnetization Detection** (Refer to Demag §)

**Foldback**

As depicted in Figure 28, the foldback input (pin 5) enables to reduce the maximum  $V_{CS}$  value that would be equal to 1 typically, if there was no foldback action. Finally, the foldback arrangement is a programmable peak current limitation.

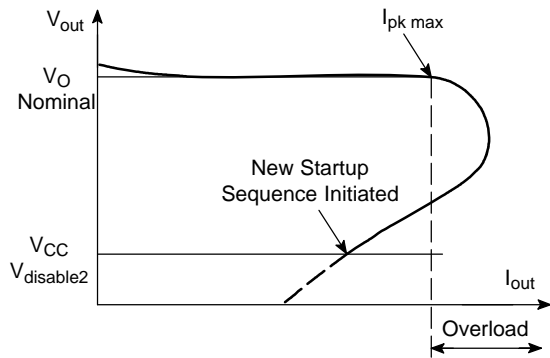


Figure 36. Foldback Characteristic

It could be used as a soft-start (by connecting to pin 5, a gradually increasing voltage) but in fact, it has been designed to provide the system with an effective overload protection.

Indeed, as the output load gradually increases, the required converter peak current becomes higher and so,

$V_{CS}$  grows up till it reaches its maximum value (normally,  $V_{CS\ max} = 1\ V$ ).

Then if the output load keeps on increasing, the system is not able to supply enough energy to maintain the output regulation. Consequently, the decreasing output can be used to apply a voltage that diminishes to a value lower than 1 V, to pin 5, in order to limit the maximum peak current. In this way, the well known foldback characteristic is obtained (refer to Figure 36).

The foldback action can be inhibited by connecting the pin 5 to  $V_{CC}$ .

**Overshoot Protection**

The overshoot arrangement consists of a comparator that compares the pin 6 voltage to  $V_{ref}$  (2,5 V) (refer to Figure 37).

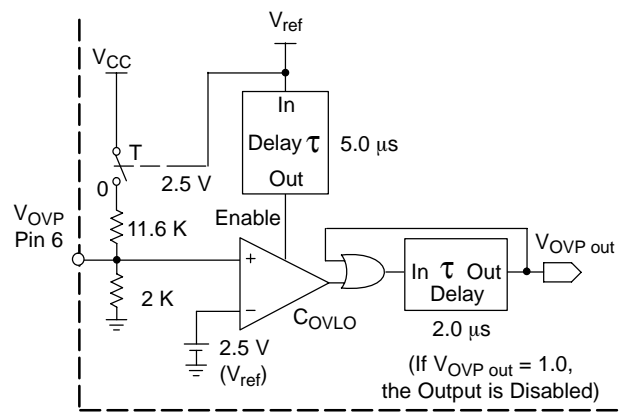


Figure 37. Overshoot Protection

If no external component is connected to pin 6, the comparator non inverting input voltage is nearly equal to:

$$\left( \frac{2\ k\Omega}{11,6\ k\Omega + 2\ k\Omega} \right) \cdot V_{CC}$$

So, the comparator output is high when:

$$\left( \frac{2\ k\Omega}{11,6\ k\Omega + 2\ k\Omega} \right) \cdot V_{CC} \geq 2,5\ V$$

$$V_{CC} \geq 17\ V$$

A delay latch ( $2\ \mu s$ ) is incorporated in order to only take into account the overvoltages that last at least  $2\ \mu s$ .

If this condition is achieved,  $V_{OVP\ out}$  the delay latch output becomes high and as this level is brought back to the input through an OR gate,  $V_{OVP\ out}$  remains high (and so, the IC output is disabled) until  $V_{ref}$  is disabled.

Consequently when an overvoltage longer than  $2\ \mu s$  is detected, the output is disabled until a new circuit restart.

The  $V_{CC}$  is connected when once the circuit has started-up in order to limit the circuit startup consumption (T is switched on when once  $V_{ref}$  has been generated).

The overvoltage section is enabled 5 μs after the regulator has started to allow the reference V<sub>ref</sub> to stabilize.

By connecting external resistors to pin 6, the threshold V<sub>CC</sub> level can be changed.

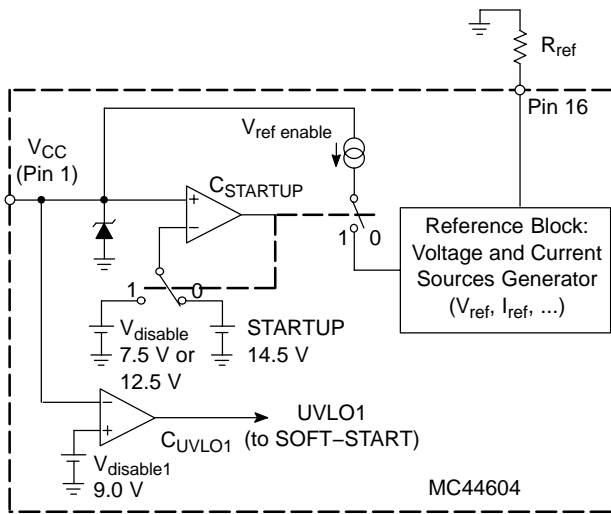


Figure 38. V<sub>CC</sub> Management

**Undervoltage Lockout Section**

As depicted in Figure 39, an undervoltage lockout has been incorporated to guarantee that the IC is fully functional before allowing operation of the system.

Indeed, the V<sub>CC</sub> is connected to the non inverting input of a comparator that has an upper threshold equal to 14,5 V (V<sub>stup-th</sub>) and a lower one equal to 7.5 V (V<sub>disable2</sub>) in normal mode and 14.5 V and 12.5 V in Standby mode (typical values) (Note 1).

This hysteresis comparator enables or disables the reference block that generates the voltage and current sources required by the system.

This block particularly, produces V<sub>ref</sub> (pin 16 voltage) and I<sub>ref</sub> that is determined by the resistor R<sub>ref</sub> connected between pin 16 and the ground:

$$I_{ref} = \frac{V_{ref}}{R_{ref}} \text{ where } V_{ref} = 2.5 \text{ V (typically)}$$

In addition to this, V<sub>CC</sub> is compared to a second threshold level that is nearly equal to 9 V (V<sub>disable1</sub>) so that in normal mode, a signal UVLO1 is generated to reset the maximum duty cycle and soft-start block and so, to disable the output stage (refer to Max. Duty Cycle and Soft-Start §) as soon as V<sub>CC</sub> becomes lower than V<sub>disable1</sub>. In this way, the circuit is reset and made ready for a next startup, before the reference block is disabled (refer to Figure 26). In standby, UVLO1 is not active (there is no need to discharge the soft-start capacitor as the soft-start pin is maintained short circuited).

Note 1. In standby the difference between V<sub>disable2</sub> and V<sub>stup-th</sub> is decreased not to have too low pulsed mode frequencies.

Thus, finally in normal mode, the upper V<sub>CC</sub> limit that enables the output to be active, is 9.4 V (maximum value of V<sub>disable1</sub>) and so the minimum hysteresis is 4.2 V. [(V<sub>stup-th</sub>)<sub>min</sub> = 13.6 V].

The large hysteresis and the low startup current of the MC44604 make it ideally suited for off-line converter applications where efficient bootstrap startup techniques are required.

**Standby Management**

The MC44604 has been designed to detect the transitions between the standby and normal mode and to manage each mode in an optimal way.

In standby, the device monitors a pulsed mode that enables to drastically reduce the power consumption.

**Pulsed Mode**

The MC44604 standby is preferably associated to a flyback configuration as depicted in Figure 39.

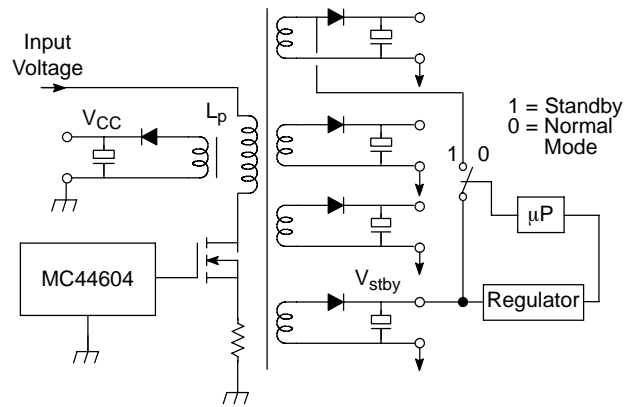


Figure 39. Standby Flyback Configuration

In effect, by this means, all the output regulation levels are divided by the ratio:

$$\frac{V_{HV}}{V_{stby}}$$

where V<sub>HV</sub> is the normal mode high voltage regulation level, V<sub>stby</sub> is the standby μP supply voltage.

For instance, in the case of TV or monitors applications, the output levels (except the μP supply voltage, V<sub>stby</sub>) are drastically reduced by a ratio in the range of 10.

Consequently, as the output voltages are reduced, the losses due to the output leakage consumption, are practically eliminated, without having to disconnect the loads.

**Startup Operations**

The choice of the right configuration (normal or standby) is performed at each startup.

That is why, as explained in the transitions §, at each change of mode, the MC44604 is first turned off so that a new startup should be performed.

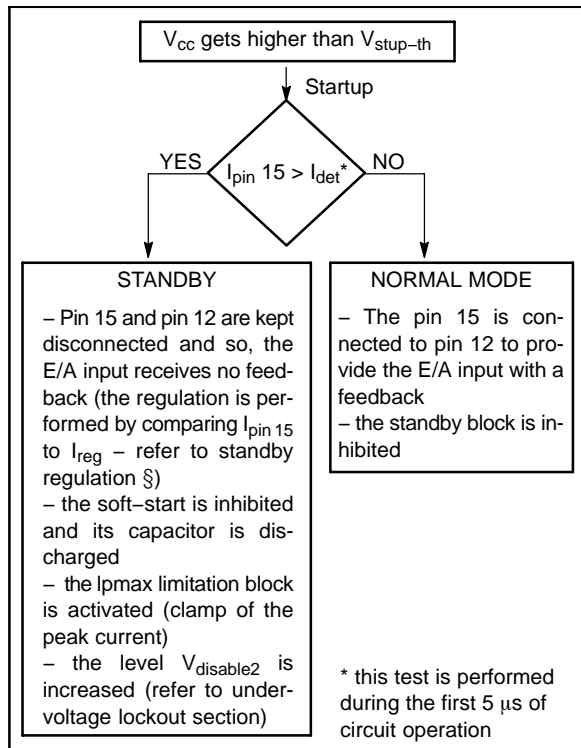


Figure 40. Startup Operation

At each startup, the circuit detects if it must work in standby or in normal mode configuration.

To do that, the circuit compares the current  $I_{pin15}$  to  $I_{det}$  so that, if:

- $I_{pin15} > I_{det}$ : Standby mode
- $I_{pin15} < I_{det}$ : Normal mode

According to the detected mode, the circuit configuration is set (refer to Figure 40).

This detection phase takes place during the first 5 µs of circuit operation in order to have the internal signals well stabilized before the decision is taken.

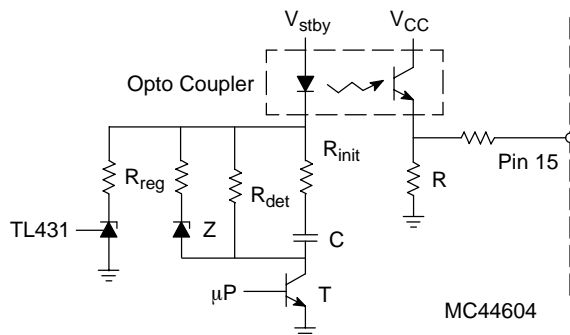


Figure 41. Standby Pin 15 Arrangement

**Standby Management**

The standby operation consists of two main phases:

- the **off phase** during which the MC44604 is off. During this sequence, the circuit  $V_{cc}$  is being charged and no energy is transferred to the output.
- the **active phase** during which the MC44604 is on. At this moment, some power can be drawn from the mains.

During the active phase, the power conversion is controlled so that:

- the normal mode regulation means (error amplifier) and the soft-start are inhibited
- the  $V_{cc}$  undervoltage lockout ( $V_{disable2}$ ) level is increased from 9 V up to 12.5 V. This limitation of the  $V_{cc}$  hysteresis enables to increase the pulsed mode frequency
- the peak inductor current is forced to be constant and equal to the level programmable by the external resistor  $R_{Ipmax}$  connected to the pin 9 so that:

$$I_{pmax} = \frac{0,4 \times I_{ref} \times R_{Ipmax}}{2,6 \times R_S}$$

where:  $I_{pmax}$  is the standby inductor peak current,  $R_S$  is the current sense resistor.

- when the pin 15 current gets higher than the threshold  $I_{reg}$  ( $20.5 \times I_{ref}$ ), this operating mode stops and the circuit output is latched off.

So, in fact, the active phase is split into two distinct sequences and finally three phases can be defined (refer to Figure 32):

- the **off phase**: the MC44604 is off and the  $V_{cc}$  capacitor is being charged. When the  $V_{cc}$  gets higher than  $V_{stup-th}$ , the circuit turns on and the switching sequence starts
- the **switching phase**: the circuit is on and forces a constant peak inductor current. This sequence lasts until  $I_{pin15}$  gets higher than  $I_{reg}$
- the **latched phase**: the circuit is on but the output is disabled. This sequence lasts until the standby  $V_{cc}$  undervoltage lockout voltage (12.5 V) is reached. A new off phase is then initialized.

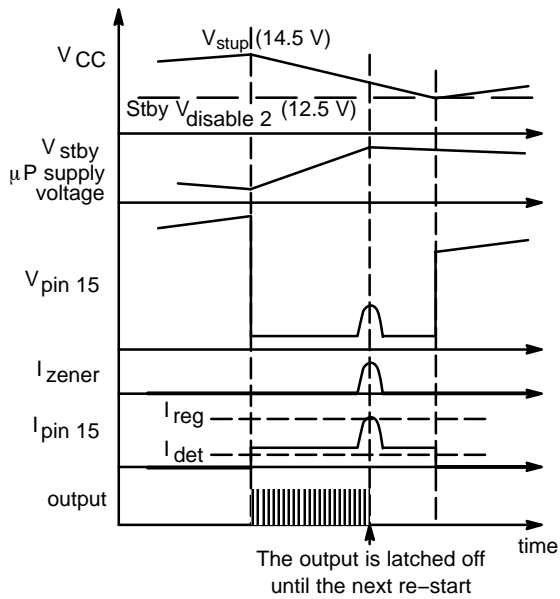


Figure 42. Standby Regulation

As a consequence,  $V_{stby}$  varies between a peak value (obtained at the end of the switching phase) and a valley level (reached at the end of the off phase).

The level of the peak value is controlled by forcing a current higher than  $I_{reg}$  in pin 15 when this level has reached the desired value.

The arrangement in Figure 41 allows to obtain this operation. A zener diode Z is connected so that a current limited by  $R_{reg}$ , is drawn by this device, when the  $\mu P$  supply voltage gets higher than  $V_z$ . By this way, the current injected in the pin 15 increases and when this current is detected as higher than  $I_{reg}$ , the output gets disabled until the next startup (Note 1).

Practically, the pin 15 current can be expressed as follows (when the zener is activated):

$$I_{pin15} = CTR \times \frac{V_{stby} - V_{opto} - V_z}{R_{reg}}$$

where: CTR is the opto coupler gain,  $V_{opto}$  is opto coupler voltage drop.

So, as the  $V_{stby}$  peak value is obtained when ( $I_{pin15} = I_{reg}$ ), it can be calculated using the following equation:

$$V_{stby\ pk} = V_z + V_{opto} + \frac{R_{reg} \times I_{reg}}{CTR}$$

Practically,  $R_{reg}$  is chosen very low (in the range of 10  $\Omega$ , low resistance just to limit the current when  $V_{stby\ pk}$  gets higher than  $V_z$ ):

$$V_{stby\ pk} \cong V_z + V_{opto}$$

Note 1. If the pin 15 current is higher than  $I_{reg}$  at startup, the output is just shutdown but not latched. The circuit must

detect a sequence during which  $I_{pin15}$  lower than  $I_{reg}$  before being able to latch gets higher than  $V_z$ ).

**Transitions Between Normal Mode and Standby Mode** (Refer to Figure 43)

The MC44604 detects a transition by comparing the pin 15 current to:

- $I_{det}$  (transition standby to normal mode)
- $I_{init}$  (transition normal mode to standby)

Each transition detection results in the circuit turning off, so that the device can work in the new mode after the following restart.

**• transition normal mode to standby:**

This transition is detected by comparing the  $I_{pin15}$  current to the threshold current ( $I_{init}$ ).

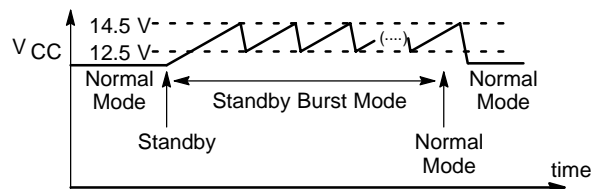
$I_{init}$  is high enough so that the opto coupler current used for the regulation, never exceeds this value.

The arrangement in Figure 41 is well adapted to this mode of operation. The  $\mu P$  initializes the standby mode by turning on the switch T. This results in the C capacitor charge that produces a peak current in the primary side of the opto coupler. C and  $R_{init}$  must be dimensioned so that the opto coupler primary side generates a pin 15 current higher than  $I_{init}$  during more than 1  $\mu s$ .

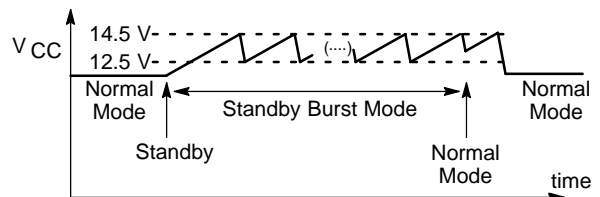
**• transition standby to normal mode:**

If the circuit detects that ( $I_{pin15} < I_{det}$ ) during standby operation, the circuit is turned off. So, if the normal mode is maintained at the following startup, the circuit will restart in a normal mode configuration.

The arrangement in Figure 41 allows to perform this detection. When the  $\mu P$  detects the end of the standby, it turns off the switch T and the opto coupler stops supplying current to the circuit.



The transition stand-by to normal mode occurs while the circuit is off ( $V_{CC}$  charge phase)



The transition stand-by to normal mode occurs while the circuit is on (working phase)

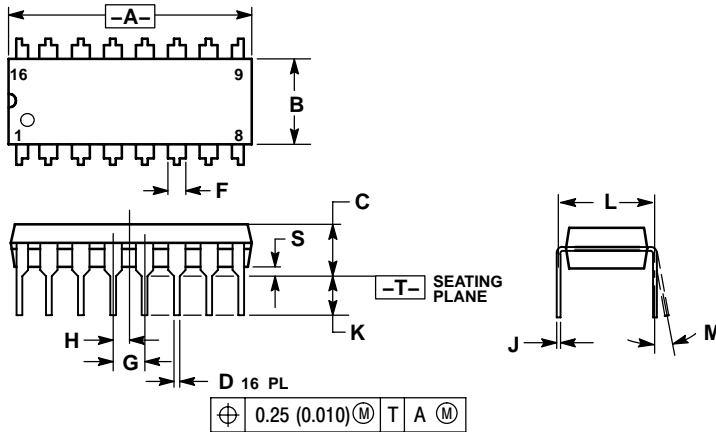
Figure 43. Transitions Between Modes



# MC44604

## PACKAGE DIMENSIONS

PDIP-16  
P SUFFIX  
CASE 648-08  
ISSUE T



**NOTES:**

1. DIMENSIONING AND TOLERANCING PER ANSI Y14.5M, 1982.
2. CONTROLLING DIMENSION: INCH.
3. DIMENSION L TO CENTER OF LEADS WHEN FORMED PARALLEL.
4. DIMENSION B DOES NOT INCLUDE MOLD FLASH.
5. ROUNDED CORNERS OPTIONAL.

DIM	INCHES		MILLIMETERS	
	MIN	MAX	MIN	MAX
A	0.740	0.770	18.80	19.55
B	0.250	0.270	6.35	6.85
C	0.145	0.175	3.69	4.44
D	0.015	0.021	0.39	0.53
F	0.040	0.70	1.02	1.77
G	0.100 BSC		2.54 BSC	
H	0.050 BSC		1.27 BSC	
J	0.008	0.015	0.21	0.38
K	0.110	0.130	2.80	3.30
L	0.295	0.305	7.50	7.74
M	0°	10°	0°	10°
S	0.020	0.040	0.51	1.01

GreenLine is a trademark of Motorola, Inc.

**ON Semiconductor** and **ON** are registered trademarks of Semiconductor Components Industries, LLC (SCILLC). SCILLC reserves the right to make changes without further notice to any products herein. SCILLC makes no warranty, representation or guarantee regarding the suitability of its products for any particular purpose, nor does SCILLC assume any liability arising out of the application or use of any product or circuit, and specifically disclaims any and all liability, including without limitation special, consequential or incidental damages. "Typical" parameters which may be provided in SCILLC data sheets and/or specifications can and do vary in different applications and actual performance may vary over time. All operating parameters, including "Typicals" must be validated for each customer application by customer's technical experts. SCILLC does not convey any license under its patent rights nor the rights of others. SCILLC products are not designed, intended, or authorized for use as components in systems intended for surgical implant into the body, or other applications intended to support or sustain life, or for any other application in which the failure of the SCILLC product could create a situation where personal injury or death may occur. Should Buyer purchase or use SCILLC products for any such unintended or unauthorized application, Buyer shall indemnify and hold SCILLC and its officers, employees, subsidiaries, affiliates, and distributors harmless against all claims, costs, damages, and expenses, and reasonable attorney fees arising out of, directly or indirectly, any claim of personal injury or death associated with such unintended or unauthorized use, even if such claim alleges that SCILLC was negligent regarding the design or manufacture of the part. SCILLC is an Equal Opportunity/Affirmative Action Employer. This literature is subject to all applicable copyright laws and is not for resale in any manner.

### PUBLICATION ORDERING INFORMATION

**LITERATURE FULFILLMENT:**  
Literature Distribution Center for ON Semiconductor  
P.O. Box 61312, Phoenix, Arizona 85082-1312 USA  
**Phone:** 480-829-7710 or 800-344-3860 Toll Free USA/Canada  
**Fax:** 480-829-7709 or 800-344-3867 Toll Free USA/Canada  
**Email:** orderlit@onsemi.com

**N. American Technical Support:** 800-282-9855 Toll Free  
USA/Canada

**Japan:** ON Semiconductor, Japan Customer Focus Center  
2-9-1 Kamimeguro, Meguro-ku, Tokyo, Japan 153-0051  
**Phone:** 81-3-5773-3850

**ON Semiconductor Website:** <http://onsemi.com>

**Order Literature:** <http://www.onsemi.com/litorder>

For additional information, please contact your local Sales Representative.

**MC44604/D**