

(3.3V) V23826-H18-C(*)

Single Mode 622 MBd ATM/SDH/SONET 1x9 Transceiver Extended Temperature Range (-40°C to 85°C)

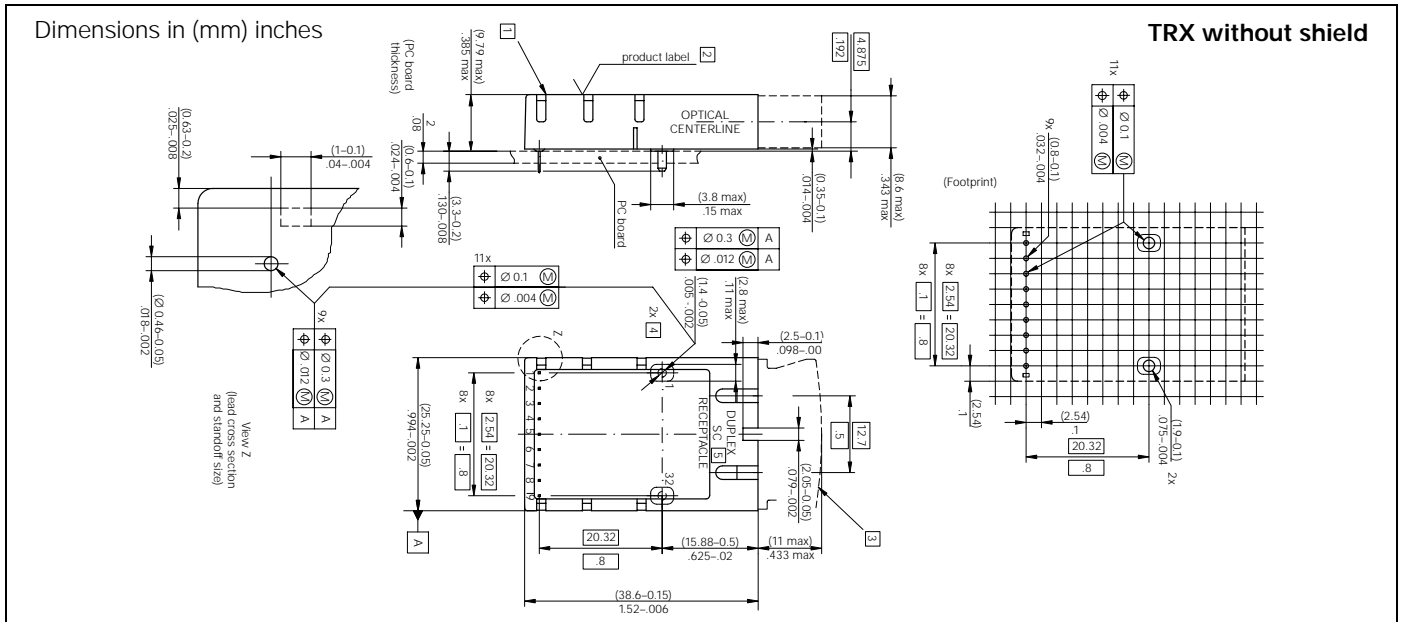

Absolute Maximum Ratings

Exceeding any one of these values may destroy the device immediately.

Package Power Dissipation ⁽¹⁾	0.9 W
Supply Voltage ($V_{CC}-V_{EE}$)	3.3 V
Data Input Levels	$V_{CC}+0.5$ V
Differential Data Input Voltage	2.5 V
Operating Ambient Temperature	-40°C to 85°C
Storage Ambient Temperature	-40°C to 85°C
Soldering Conditions Temp/Time (MIL-STD 883C, Method 2003)	250°C/5.5s

Note

- For $V_{CC}-V_{EE}$ (min., max.). 50% duty cycle. The supply current does not include the load drive current of the receiver output.

FEATURES

- Compliant with ATM, SONET OC-3, SDH STM-1 and SONET OC-12, SDH STM-4
- Meets mezzanine standard height of 9.8 mm
- Compact integrated transceiver unit with
 - MQW laser diode transmitter
 - InGaAs PIN photodiode receiver
 - Duplex SC receptacle
- Class 1 FDA and IEC laser safety compliant
- FDA Accession No. 9520890-12, 9520890-13
- Single power supply (3.3 V)
- Signal detect indicator (PECL and TTL versions)
- PECL differential inputs and outputs
- Process plug included
- Input Signal Monitor (DC/DC Version)
- Wave solderable and washable with process plug inserted
- Industry standard multisource 1x9 footprint
- For distances of up to 15 km on single mode fiber

*) Ordering Information

Input	Output	Signal detect	Voltage	Part number
AC	DC	PECL	3.3 V	V23826-H18-C316
AC	AC	TTL	3.3 V	V23826-H18-C356
DC	DC	PECL	3.3 V	V23826-H18-C366 ⁽¹⁾
AC	AC	PECL	3.3 V	V23826-H18-C376
Shield options				Add suffix to PIN
Metallized cover, forward springs				-C3
Metallized cover, backward springs				-D3

Note

- Standard version

DESCRIPTION

The Infineon single mode ATM transceiver complies with the ATM Forum's *Network Compatible ATM for Local Network Applications* document and ANSI's *Broadband ISDN—Customer Installation Interfaces, Physical Media Dependent Specification*, T1.646-1995, Bellcore - SONET OC-3 / IR-1 and OC-12 / IR-1, ITU-T G.957 STM-1 / S.1.1. and STM-4 / S.4.1. ATM was developed to facilitate solutions in multimedia applications and real time transmission. The data rate is scalable, and the ATM protocol is the basis of the broadband public networks being standardized in the International Telecommunications Union (ITU), the former International Telegraph and Telephone Consultative Committee (CCITT). ATM can also be used in local private applications.

The Infineon single mode ATM transceiver is a single unit comprised of a transmitter, a receiver, and an SC receptacle. This design frees the customer from many alignment and PC board layout concerns. The module is designed for low cost WAN applications. It can be used as the network end device interface in workstations, servers, and storage devices, and in a broad range of network devices such as bridges, routers, and intelligent hubs, as well as wide area ATM switches.

This transceiver operates at 622.080 Mbit/s from a single power supply (+3.3 Volt). The differential data inputs and outputs are PECL compatible.

Functional Description

This transceiver is designed to transmit serial data via single mode cable.

Functional Diagram

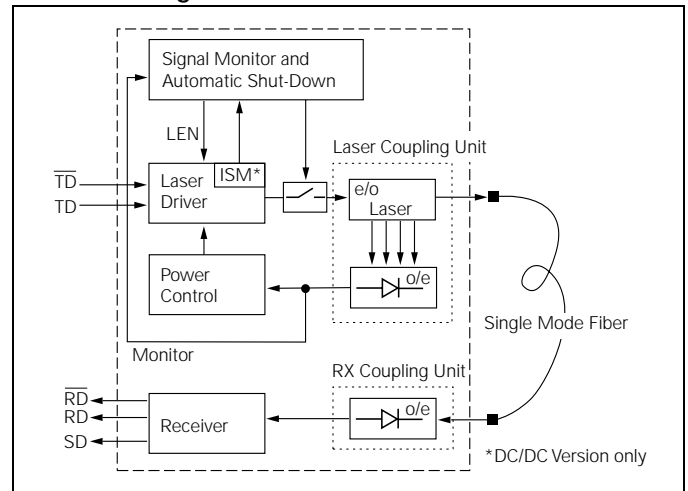

The receiver component converts the optical serial data into PECL compatible electrical data (RD and RDnot). The Signal Detect (SD, active high) shows whether optical data is present⁽¹⁾.

The transmitter converts electrical PECL compatible serial data (TD and TDnot) into optical serial data.

The following versions are available:

1. AC/DC Transceiver

Tx is AC coupled with differential 100 Ω load. Rx has standard PECL output and is DC coupled.

2. AC/AC TTL Transceiver

Tx and Rx are AC coupled. Tx has differential 100 Ω load. Signal Detect is TTL compatible.

3. DC/DC Transceiver

Standard PECL inputs and outputs Tx and Rx are DC coupled. This version contains an Input Signal Monitor (ISM), that switches off the optical power if a continuously low level is applied at Data Input.

4. AC/AC PECL Transceiver

Tx and Rx are AC coupled. Tx has differential 100 Ω load. Signal Detect is PECL compatible.

The transmitter contains a laser driver circuit that drives the modulation and bias current of the laser diode. The currents are controlled by a power control circuit to guarantee constant output power of the laser over temperature and aging.

The power control uses the output of the monitor PIN diode (mechanically built into the laser coupling unit) as a controlling signal, to prevent the laser power from exceeding the operating limits.

Single fault condition is ensured by means of an integrated automatic shutdown circuit that disables the laser when it detects transmitter failures. A reset is only possible by turning the power off, and then on again.

The transceiver contains a supervisory circuit to control the power supply. This circuit generates an internal reset signal whenever the supply voltage drops below the reset threshold. It keeps the reset signal active for at least 15 milliseconds after the voltage has risen above the reset threshold. During this time the laser is inactive.

Note

1. We recommend to switch off the transmitter supply (V_{CC-Tx}) if no transmitter input data is applied.

TECHNICAL DATA

The electro-optical characteristics described in the following tables are only valid for use under the recommended operating conditions.

Recommended Operating Conditions

Parameter	Symbol	Min.	Typ.	Max.	Units
Ambient Temperature	T_{AMB}	-40		85	°C
Power Supply Voltage	3.3 V $V_{CC-V_{EE}}$	3.1	3.3	3.5	V
Supply Current ⁽¹⁾	3.3 V I_{CC}		160	250	mA
Transmitter					
Data Input High Voltage DC/DC	$V_{IH-V_{CC}}$	-1165		-880	mV
Data Input Low Voltage DC/DC	$V_{IL-V_{CC}}$	-1810		-1475	
Data Input Differential Voltage AC/DC, AC/AC TTL, AC/AC PECL	V_{DIFF}	250		1600	
Input Data Rise/Fall Time 10%–90%	t_R, t_F	100		1300	ps
Receiver					
Input Center Wavelength	λ_C	1270		1356	nm

Note

- For $V_{CC-V_{EE}}$ (min., max.) 50% duty cycle. The supply current does not include the load drive current of the receiver output.

Transmitter Electro-Optical Characteristics

Transmitter	Symbol	Min.	Typ.	Max.	Units
Launched Power (Average) ⁽¹⁾	P_O	-15	-11	-8	dBm
Center Wavelength	λ_C	1274		1356	nm
Spectral Width (RMS)	σ_I			2.5	
Relative Intensity Noise	RIN			-120	dB/Hz
Extinction Ratio (Dynamic)	ER	8.2			dB
Reset Threshold ⁽²⁾	3.3 V V_{TH}		2.7		V
Reset Time Out ⁽²⁾	t_{RES}	15	22	35	ms
Eye Diagram ⁽³⁾	ED				

Notes

- Into single mode fiber, 9 μ m diameter.
- Laser power is shut down if power supply is below V_{TH} and switched on if power supply is above V_{TH} after t_{RES} .
- Transmitter meets ANSI T1E1.2, SONET OC-3 and OC-12, and ITU-T G.957 mask patterns.

Receiver Electro-Optical Characteristics

Receiver	Symbol	Min.	Typ.	Max.	Units
Sensitivity (Average Power) ⁽¹⁾	P_{IN}		-30	-28	dBm
Saturation (Average Power)	P_{SAT}	-8			
Signal Detect Assert Level ⁽²⁾	P_{SDA}			-28	
Signal Detect Deassert Level ⁽³⁾	P_{SDD}	-38			
Signal Detect Hysteresis	$P_{SDA}-P_{SDD}$		1.5		dB
Signal Detect Assert Time	t_{ASS}			100	μ s
Signal Detect Deassert Time	t_{DAS}			350	
Output Low Voltage ⁽⁴⁾	$V_{OL-V_{CC}}$	-1950		-1620	mV
Output High Voltage ⁽⁴⁾	$V_{OH-V_{CC}}$	-1025		-720	
Signal Detect Output Voltage AC/AC TTL ⁽⁵⁾	Low	V_{SDL}		0.5	V
	High	V_{SDH}	2		
Data Output Differential Voltage ⁽⁶⁾	V_{DIFF}	0.5	0.8	1.23	
Output Data Rise/Fall Time, 20%–80%	t_R, t_F			375	ps
Return Loss of Receiver	A_{RL}	12			dB

Notes

- Minimum average optical power at which the BER is less than 1×10^{-12} or lower. Measured with a 2²³-1 NRZ PRBS as recommended by ANSI T1E1.2, SONET OC-3 and OC-12, and ITU-T G.957.
- An increase in optical power of data signal above the specified level will cause the SIGNAL DETECT to switch from a Low state to a High state.
- A decrease in optical power of data signal below the specified level will cause the SIGNAL DETECT to switch from a High state to a Low state.
- DC/DC, AC/DC for data
DC/DC, AC/DC, AC/AC PECL for Signal Detect
PECL compatible. Load is 50 Ω into $V_{CC} - 2$ V for data, 270 Ω (3.3 V) to V_{EE} for Signal Detect. Measured under DC conditions. For dynamic measurements a tolerance of 50 mV should be added. $V_{CC}=3.3$ V. $T_{AMB}=25^\circ$ C.
- Max. output current high: -0.4 mA (drive current)
low: +2.0 mA (sink current)
- AC/AC for data. Load 50 Ω to GND or 100 Ω differential. For dynamic measurement a tolerance of 50mV should be added.

Pin Description

Pin Name	Level/Logic	Pin#	Description	
RxV _{EE}	Rx Ground	Power Supply	1	Negative power supply, normally ground
RD	Rx Output Data	PECL Output	2	Receiver output data
RDn			3	Inverted receiver output data
SD	Rx Signal Detect	PECL or TTL	4	A high level on this output shows that optical data is applied to the optical input.
RxV _{CC}	Rx 3.3 V	Power Supply	5	Positive power supply, 3.3 V
TxV _{CC}	Tx 3.3 V		6	
TDn	Tx Input Data	PECL Input	7	Inverted transmitter input data
TD			8	Transmitter input data
TxV _{EE}	Tx Ground	Power Supply	9	Negative power supply, normally ground
	Stud Pin	Mech. Support	S1/2	Not connected

Regulatory Compliance

Feature	Standard	Comments
Electrostatic Discharge (ESD) to the Electrical Pins	MIL-STD 883C Method 3015.4	Class 1 (>1000 V)
Immunity: Electrostatic Discharge (ESD) to the Duplex SC Receptacle	EN 61000-4-2 IEC 61000-4-2	Discharges of ±15kV with an air discharge probe on the receptacle cause no damage.
Immunity: Radio Frequency Electromagnetic Field	EN 61000-4-3 IEC 61000-4-3	With a field strength of 3 V/m rms, noise frequency ranges from 10 MHz to 1 GHz. No effect on transceiver performance between the specification limits.
Emission: Electromagnetic Interference EMI	FCC Class B EN 55022 Class B CISPR 22	Noise frequency range: 30 MHz to 6 GHz; Margins depend on PCB layout and chassis design

EYE SAFETY

This laser based single mode transceiver is a Class 1 product. It complies with IEC 60825-1 and FDA 21 CFR 1040.10 and 1040.11.

To meet laser safety requirements the transceiver shall be operated within the Absolute Maximum Ratings.

Caution

All adjustments have been made at the factory prior to shipment of the devices. No maintenance or alteration to the device is required.
Tampering with or modifying the performance of the device will result in voided product warranty.

Note

Failure to adhere to the above restrictions could result in a modification that is considered an act of "manufacturing," and will require, under law, recertification of the modified product with the U.S. Food and Drug Administration (ref. 21 CFR 1040.10 (i)).

Laser Data

Wavelength	1300 nm
Total output power (as defined by IEC: 50 mm aperture at 10 cm distance)	less than 2 mW
Total output power (as defined by FDA: 7 mm aperture at 20 cm distance)	less than 180 µW
Beam divergence	4°

Required Labels

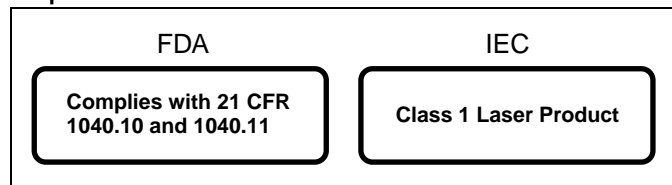

Laser Emission

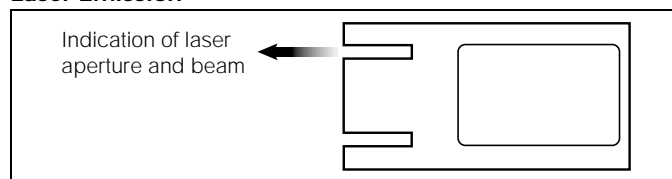

APPLICATION NOTE

ATM transceivers and matching circuits are high frequency components and shall be terminated as recommended in the application notes for proper EMI performance. Electromagnetic emission may be caused by these components.

To prevent emissions it is recommended that cutouts for the fiber connectors be designed as small as possible.

It is recommended that the Tx plug and the Rx plug be separated with a bar that divides the duplex SC opening.

APPLICATION NOTE

Single Mode 622 MBd ATM 1x9 Transceiver, DC/DC Version

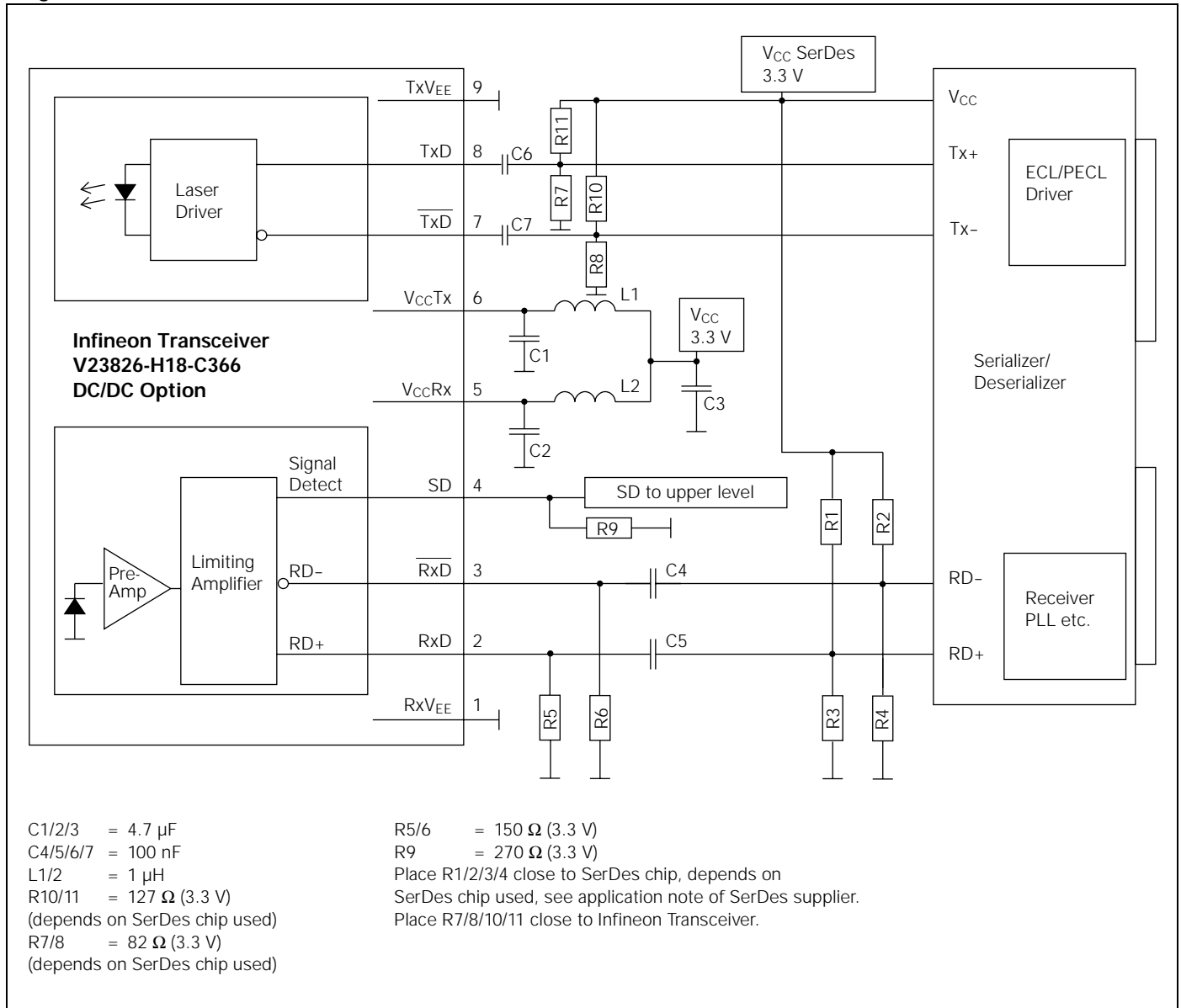

3.3 V-Transceivers can be directly connected to SerDes-Chips using standard PECL Termination network.

Value of R1...R4 may vary as long as proper 50 Ω termination to V_{EE} or 100 Ω differential is provided. The power supply filtering is required for good EMI performance. Use short tracks from the inductor L1/L2 to the module V_{CC}R_x/V_{CC}T_x. Further application notes for electrical interfacing are available upon request. Ask for Appnote 82.

We strongly recommend a V_{EE} plane under the module for getting good EMI performance.

The transceiver contains an automatic shutdown circuit. Reset is only possible if the power is turned off, and then on again. (V_{CC}T_x switched below V_{TH}).

Application Board available on request.

APPLICATION NOTE

Single Mode 622 MBd ATM 1x9 Transceiver, AC/DC Version

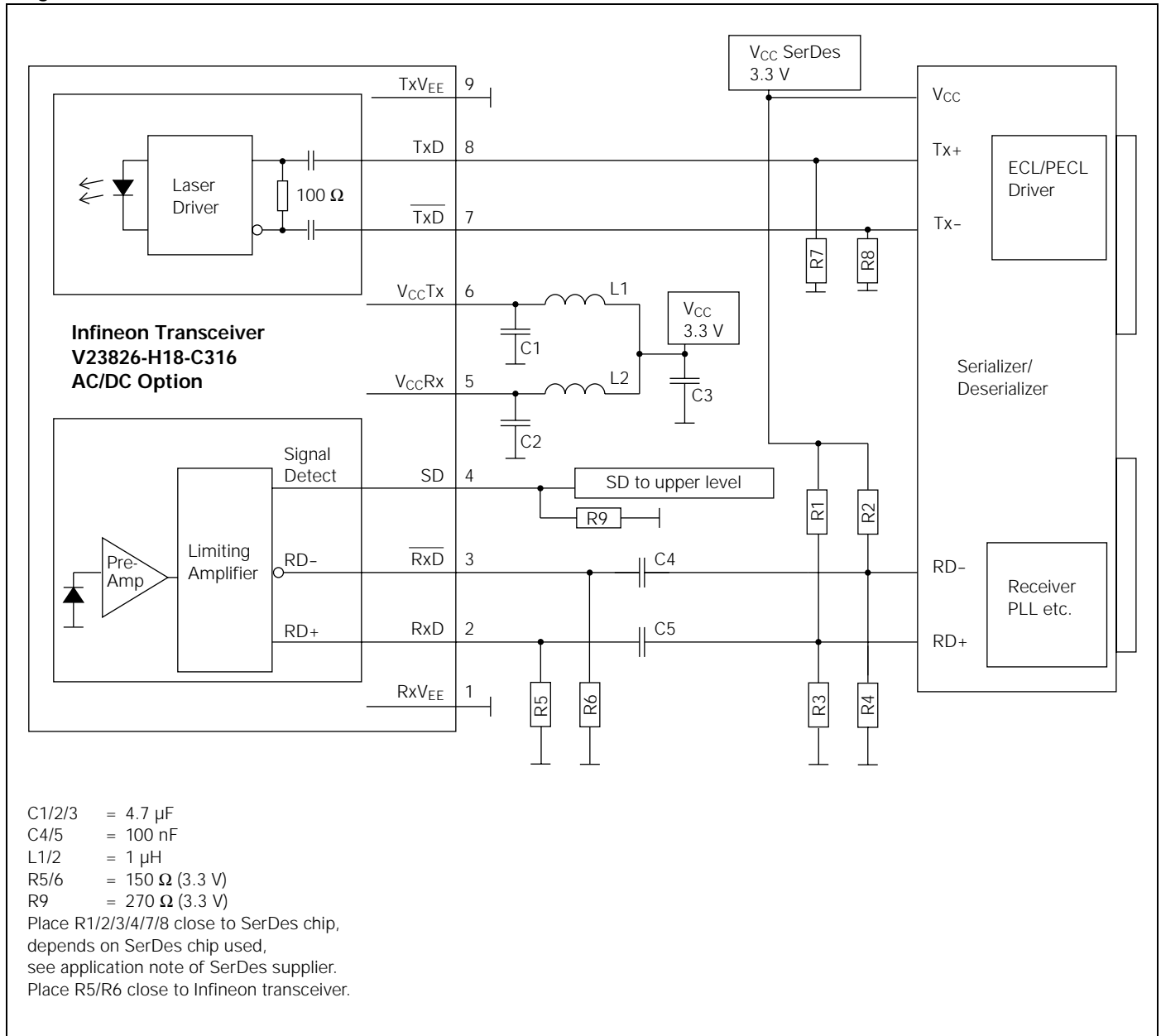

Values of R1/2/3/4 may vary as long as proper 50 Ω termination to V_{EE} or 100 Ω differential is provided. The power supply filtering is required for good EMI performance. Use short tracks from the inductor L1/L2 to the module V_{CCRx}/V_{CCTx} . Further application notes for electrical interfacing are available upon request. Ask for Appnote 82.

We strongly recommend a V_{EE} plane under the module for getting good EMI performance.

The transceiver contains an automatic shutdown circuit. Reset is only possible if the power is turned off, and then on again. (V_{CCTx} switched below V_{TH}).

Application Board available on request.

APPLICATION NOTE

Single Mode 622 MBd ATM 1x9 Transceiver, AC/AC TTL and AC/AC PECL Versions

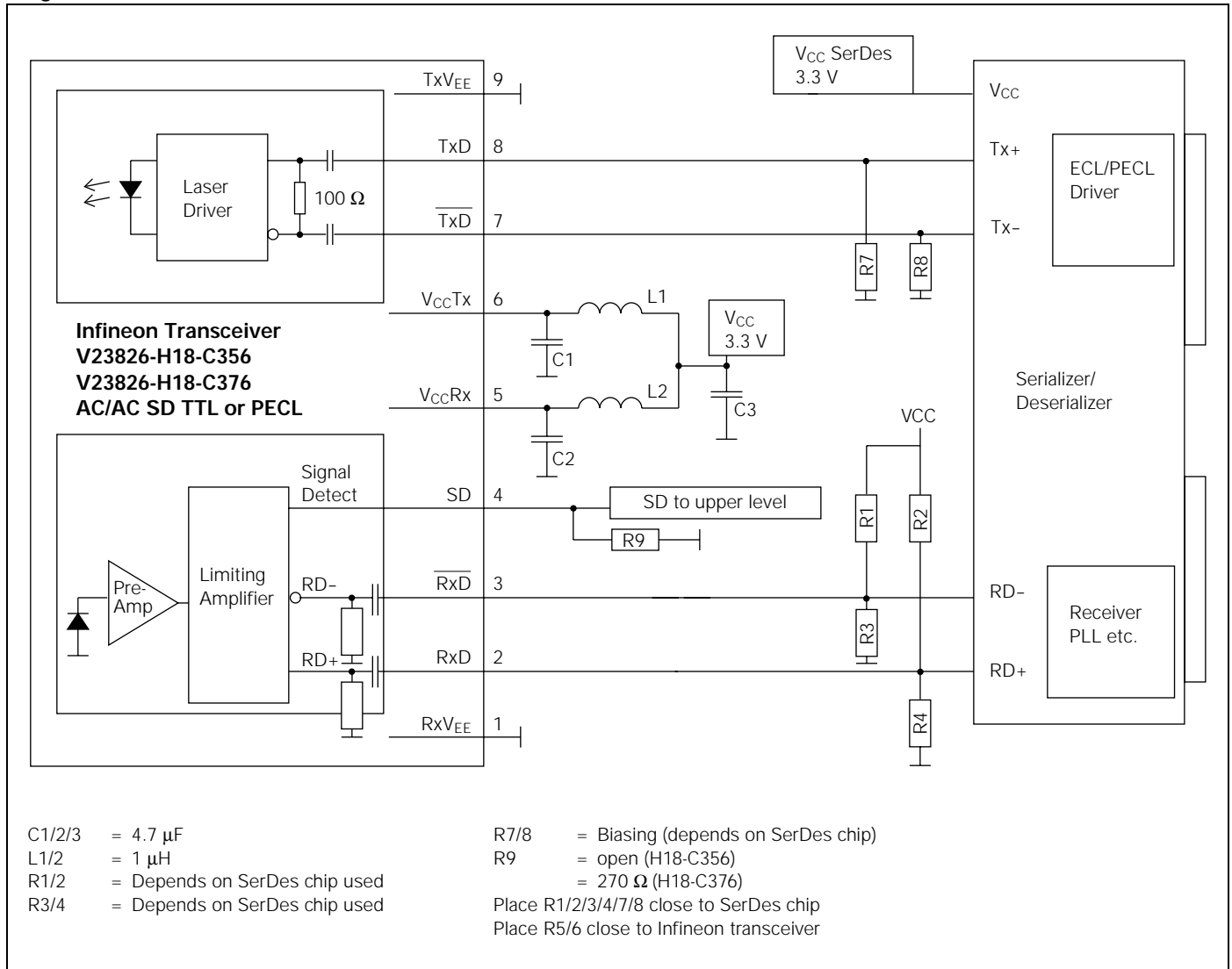

Values of R1/2/3/4 may vary as long as proper 50 Ω termination to V_{EE} or 100 Ω differential is provided. The power supply filtering is required for good EMI performance. Use short tracks from the inductor L1/L2 to the module V_{CCRx}/V_{CCTx} . Further application notes for electrical interfacing are available upon request. Ask for Appnote 82.

We strongly recommend a V_{EE} plane under the module for getting good EMI performance.

The transceiver contains an automatic shutdown circuit. Reset is only possible if the power is turned off, and then on again. (V_{CCTx} switched below V_{TH}).

Application Board available on request.

SHIELD OPTION

Shield with forward springs, -C3

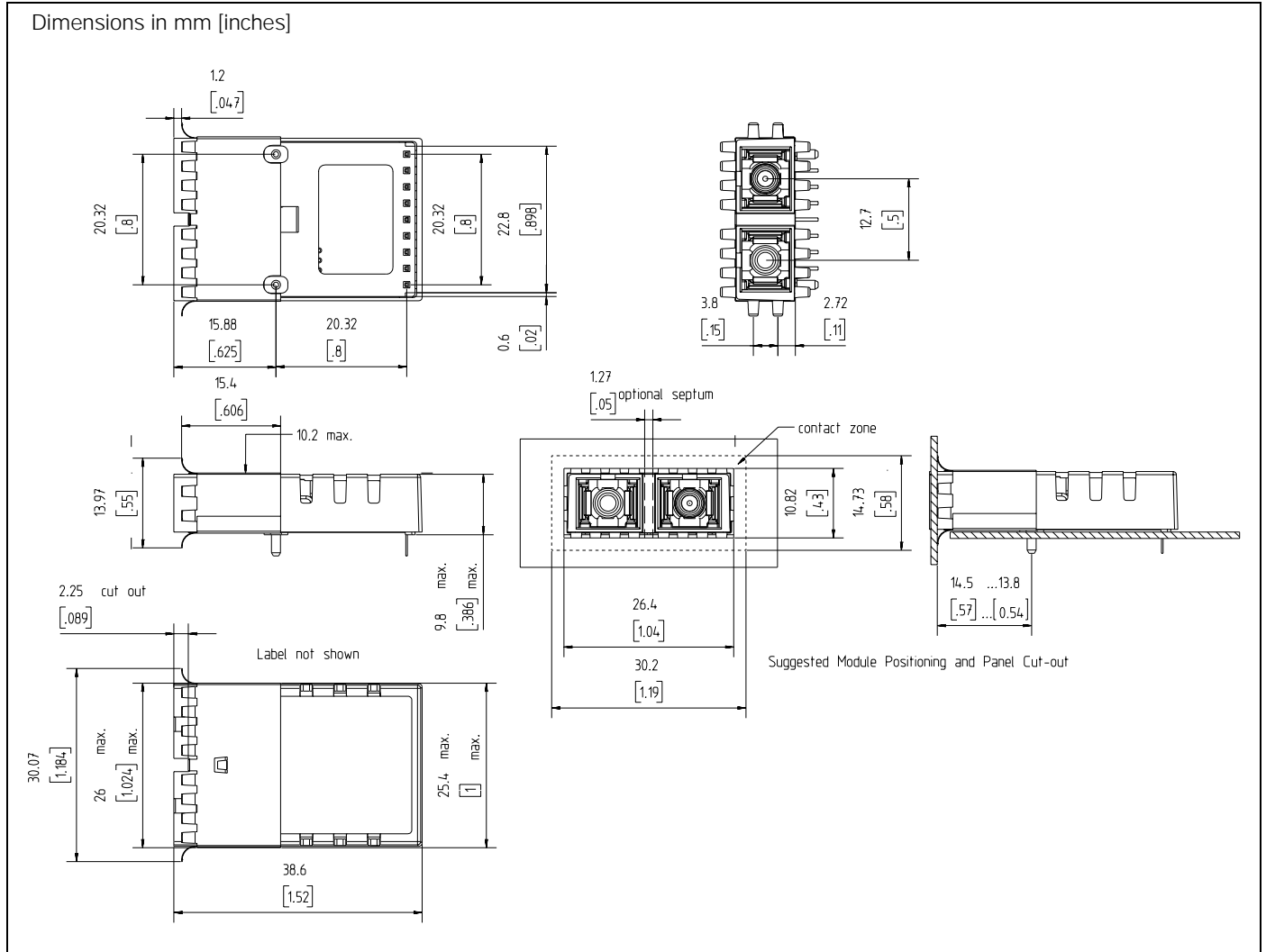

SHIELD OPTION

Shield with backward springs, -D3

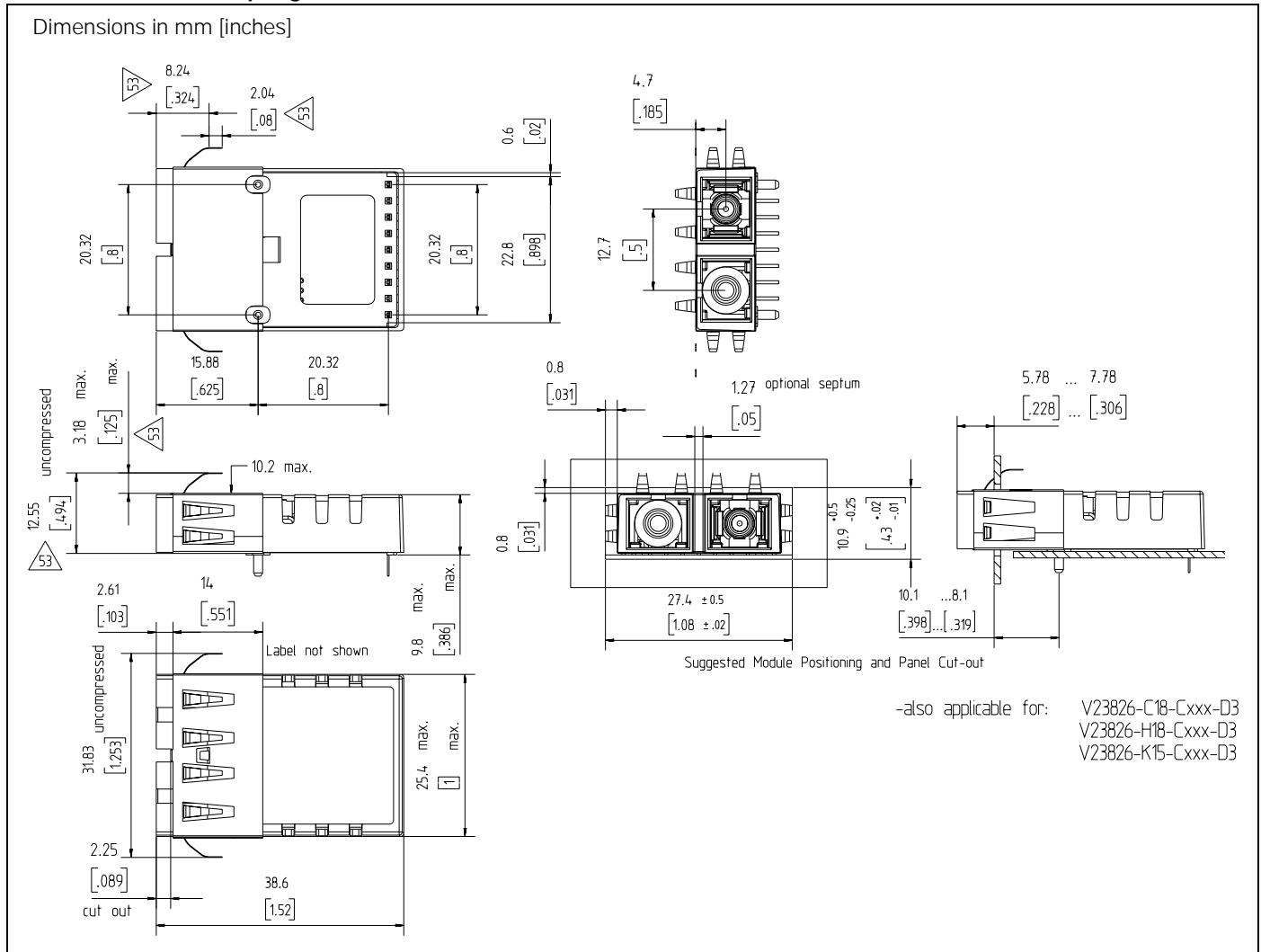

Published by Infineon Technologies AG

© Infineon Technologies AG 2000
All Rights Reserved

Attention please!

The information herein is given to describe certain components and shall not be considered as warranted characteristics.
Terms of delivery and rights to technical change reserved.
We hereby disclaim any and all warranties, including but not limited to warranties of non-infringement, regarding circuits, descriptions and charts stated herein.
Infineon Technologies is an approved CECC manufacturer.

Information

For further information on technology, delivery terms and conditions and prices please contact the Infineon Technologies offices or our Infineon Technologies Representatives worldwide - see our webpage at www.infineon.com/fiberoptics

Warnings

Due to technical requirements components may contain dangerous substances. For information on the types in question please contact your Infineon Technologies offices.

Infineon Technologies Components may only be used in life-support devices or systems with the express written approval of Infineon Technologies, if a failure of such components can reasonably be expected to cause the failure of that life-support device or system, or to affect the safety or effectiveness of that device or system. Life support devices or systems are intended to be implanted in the human body, or to support and/or maintain and sustain and/or protect human life. If they fail, it is reasonable to assume that the health of the user or other persons may be endangered.