



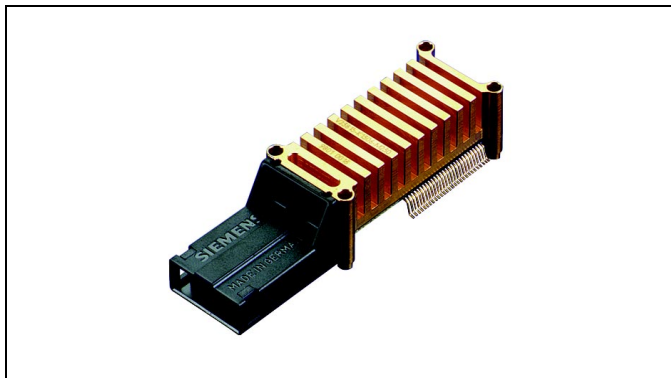
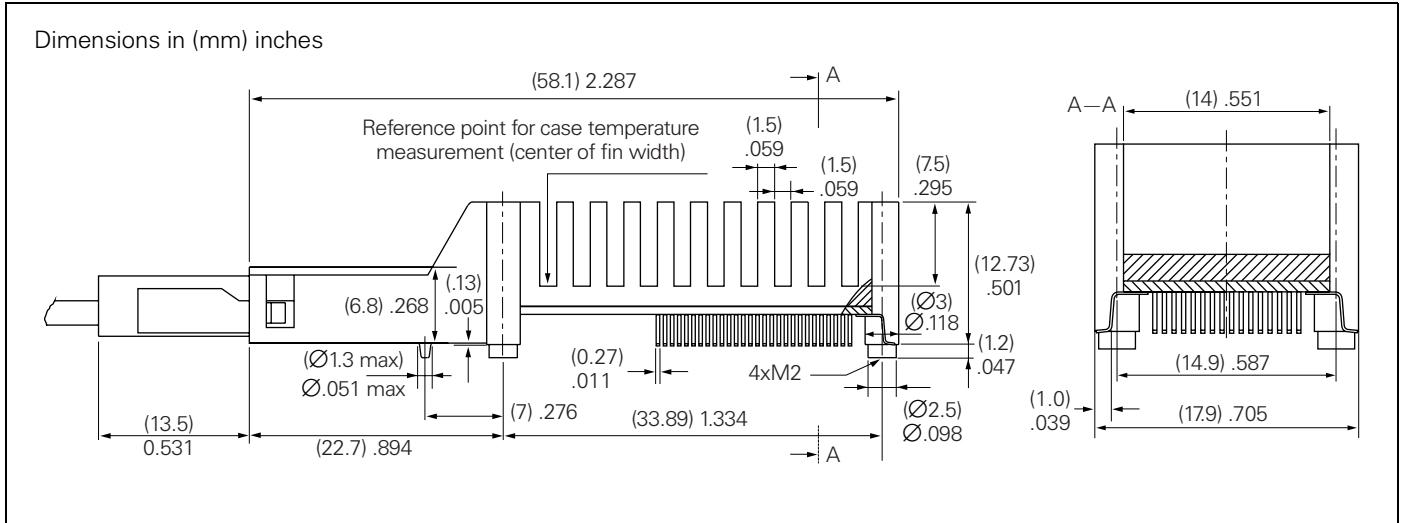
# V23814-U1306-M130

Parallel Optical Link: PAROLI™ Tx AC, 1.6 Gbit/s

# V23815-U1306-M130

Parallel Optical Link: PAROLI™ Rx AC, 1.6 Gbit/s

Preliminary



## FEATURES

- Power supply 3.3 V
- Low voltage differential signal electrical interface (LVDS)
- 12 electrical data channels
- Asynchronous, AC-coupled optical link
- 12 optical data channels
- Transmission data rate of 250-1600 Mbit/s per channel, total link data rate up to 19 Gbit/s
- Transmission distance up to 200m
- Transmitter: 840 nm VCSEL (Vertical Cavity Surface Emitting Laser) technology
- Receiver: 840 nm PIN diode array
- Fiber ribbon: 62.5 µm graded index multimode fiber
- MT based optical port
- SMD technology
- Transmitter: Class 1 FDA and Class 3A IEC laser safety compliant

## APPLICATIONS

### Telecommunication

- Switching equipment
- Access network

### Data Communication

- Interframe (rack-to-rack)
- Intraframe (board-to-board)
- On board (optical backplane)
- Interface to SCI and HIPPI 6400 standards

## Absolute Maximum Ratings

Stress beyond the values stated below may cause permanent damage to the device. Exposure to absolute maximum rating conditions for extended periods of time may affect device reliability.

Supply Voltage ( $V_{CC}-V_{EE}$ )	..... -0.3 V to 4.5 V
Data/Control Input Levels ( $V_{IN}$ ) <sup>(1)</sup>	..... -0.5 V to $V_{CC}+0.5$ V
LVDS Input Differential Voltage ( $ V_{ID} $ ) <sup>(2)</sup>	..... 2.0 V
Operating Case Temperature ( $T_{CASE}$ ) <sup>(3)</sup>	..... 0°C to 80°C
Storage Ambient Temperature ( $T_{STG}$ )	..... -20°C to 100°C
Operating Moisture	..... 20% to 85%
Storage Moisture	..... 20% to 85%
Soldering Conditions Temp/Time ( $T_{SOLD}$ , $t_{SOLD}$ ) <sup>(4)</sup>	..... 260°C/10s
ESD Resistance (all pins to $V_{EE}$ , human body model) <sup>(5)</sup>	..... 1 kV

## Notes

1. At LVDS and LVCMOS inputs.
2.  $|V_{ID}| = |(\text{input voltage of non-inverted input} - \text{input voltage of inverted input})|$ .
3. Measured at case temperature reference point (see dimensional drawing).
4. Hot bar soldering.
5. To avoid electrostatic damage the handling precautions as for MOS devices must be taken into account.

## DESCRIPTION

PAROLI is a parallel optical link for high-speed data transmission. A complete PAROLI system consists of a transmitter module, a 12-channel fiber optic cable, and a receiver module.

### Transmitter V23814-U1306-M130

The transmitter module converts parallel electrical input signals via a laser driver and a Vertical Cavity Surface Emitting Laser (VCSEL) diode array into parallel optical output signals. All input data signals are Low Voltage Differential Signals (LVDS). The data rate is 250-1600 Mbit/s for each channel. Electrical input data should be DC balanced within 144 bits. The maximum time interval of consecutive 0's and 1's (run length) should not exceed 72 bits. This will ensure that the output jitter values given for the transmitter and receiver in this data sheet will be met. Otherwise, jitter values will be exceeded.

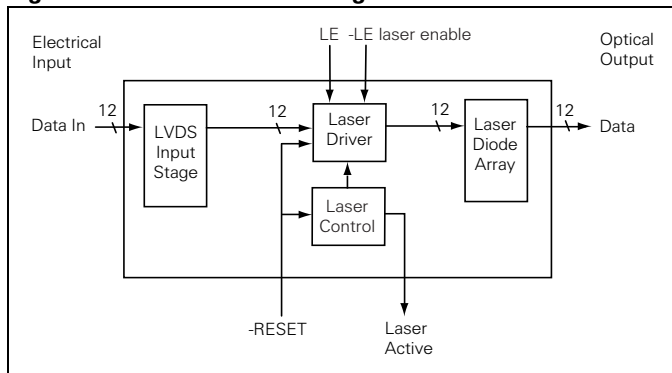
A logic low level at -RESET switches all laser outputs off. During power-up -RESET must be used as a power-on reset which disables the laser driver and laser control until the power supply has reached a 3 V level.

An additional Laser Active output is low if a laser fault is detected or -RESET is forced to low.

All nondata signals have LVCMOS levels.

Transmission delay of the PAROLI system is at a maximum 1 ns for the transmitter, 1 ns for the receiver and approximately 5 ns per meter for the fiber optic cable.

**Figure 1. Transmitter block diagram**



## LASER SAFETY

The transmitter of the AC coupled Parallel Optical Link (PAROLI) is an FDA Class 1 laser product. It complies with FDA regulations 21 CFR 1040.10 and 1040.11. The transmitter is also an IEC Class 3A laser product as defined by IEC 825-1. To avoid possible exposure to hazardous levels of invisible laser radiation, do not exceed maximum ratings.

The PAROLI module must be operated under the specified operating conditions (supply voltage between 3.0 V and 3.6 V, case temperature between 0°C and 80°C) under any circumstances to ensure laser safety.

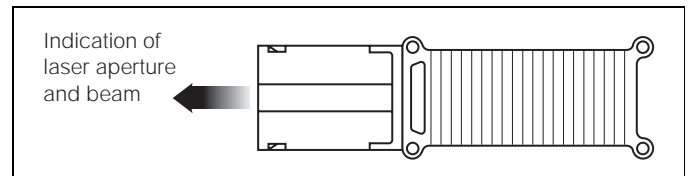
### Caution

**Do not stare into beam or view directly with optical instruments. The use of optical instruments with this product may lead to eye hazard.**

### Note

Any modification of the module will be considered an act of "manufacturing," and will require, under law, recertification of the product under FDA (21 CFR 1040.10 (i)).

## Laser Emission



## Laser safety design considerations

To ensure laser safety for all input data patterns each channel is controlled internally and will be switched off if the laser safety limits are exceeded.

An internal control unit switches the respective data channel output off if the input duty cycle permanently exceeds 57%. The alerter will not disable the channel below an input duty cycle of 57% under all circumstances.

The minimum alerter response time is 1 μs with a constant high input, i.e. in the input pattern the time interval of excessive high input (e.g. '1's in excess of a 57% duty cycle, consecutive or non-consecutive) must not exceed 1 μs, otherwise the respective channel will be switched off. The alerter switches the respective channel from off to on without the need of resetting the module.

All of the channel alerters operate independently, i.e. an alert within a channel does not affect the other channels. To decrease the power consumption of the module unused channel inputs can be tied to high input level. In this way a portion of the supply current in this channel is triggered to shut down by the corresponding alerter.

## TECHNICAL DATA

The electro-optical characteristics described in the following tables are valid only for use under the recommended operating conditions.

### Recommended Operating Conditions

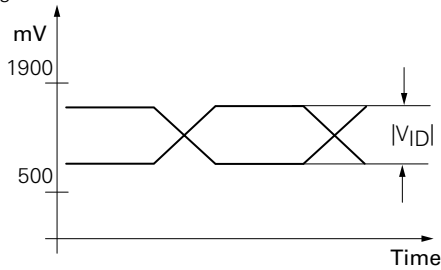
Parameter	Symbol	Min.	Max.	Units
Power Supply Voltage	V <sub>CC</sub>	3.0	3.6	V
Noise on Power Supply <sup>(1)</sup>	N <sub>PS1</sub>		10	mV
Noise on Power Supply <sup>(2)</sup>	N <sub>PS2</sub>		100	
LVDS Input Voltage Range <sup>(6)</sup>	V <sub>LVDSI</sub>	500	1900	
LVDS Input Differential Voltage <sup>(3, 6)</sup>	V <sub>ID</sub>	100	1000	
LVDS Input Skew <sup>(4)</sup>	t <sub>SPN</sub>		50	ps
LVDS Input Rise/Fall Time <sup>(5)</sup>	t <sub>R</sub> , t <sub>F</sub>	100	300	
LVCMOS Input High Voltage	V <sub>LVCMOSIH</sub>	2.0	V <sub>CC</sub>	V
LVCMOS Input Low Voltage	V <sub>LVCMOSIL</sub>	V <sub>EE</sub>	0.8	
LVCMOS Input Rise/Fall Time <sup>(7)</sup>	t <sub>R</sub> , t <sub>F</sub>		20	ns

### Notes

Voltages refer to V<sub>EE</sub>=0 V.

- Noise frequency is 1 kHz to 1 MHz. Voltage is peak-to-peak value.
- Noise frequency is 1 MHz to 1 GHz. Voltage is peak-to-peak value.
- |V<sub>ID</sub>|=(input voltage of non-inverted input minus input voltage of inverted input).
- Skew between positive and negative inputs measured at 50% level.
- 20%–80% level.

6. Level diagram:



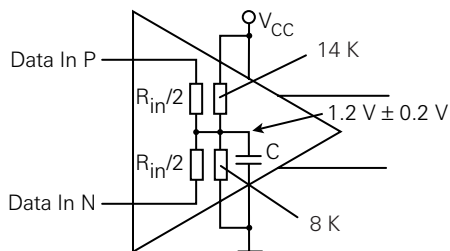
7. Measured between 0.8 V and 2.0 V.

### Transmitter Electro-Optical Characteristics

Parameter	Symbol	Min.	Typ.	Max.	Units
Supply Current	$I_{CC}$		350	450	mA
Power Consumption	P		1.2	1.6	W
Data Rate per Channel <sup>(1)</sup>	$D_R$	250		1600	MBit/s
LVC MOS Output Voltage Low	$V_{LVC MOSOL}$			0.4	V
LVC MOS Output Voltage High	$V_{LVC MOSOH}$	2.5			V
LVC MOS Input Current High/Low	$I_{LVC MOSI}$	-500		500	$\mu$ A
LVC MOS Output Current High <sup>(2)</sup>	$I_{LVC MOSOH}$			0.5	mA
LVC MOS Output Current Low <sup>(3)</sup>	$I_{LVC MOSOL}$			4.0	mA
LVDS Differential Input Impedance <sup>(4)</sup>	$R_{IN}$	80		120	$\Omega$
LVDS Input Differential Current	$ I_{II} $			5.0	mA

#### Notes

- Electrical input data should be DC balanced within 144 bits. Maximum time interval of consecutive '0's and '1's (run length) should be 72 bits.
- Source current.
- Sink current.
- LVDS Input Stage.



Parameter	Symbol	Min.	Max.	Units
Optical Rise Time <sup>(1)</sup>	$t_R$		400	ps
Optical Fall Time <sup>(1)</sup>	$t_F$			
Random Jitter ( $14\sigma$ )	$J_R$		0.23	UI
Deterministic Jitter	$J_D$		0.20	
Channel-to-channel skew <sup>(2)</sup>	$t_{CSK}$		75	ps

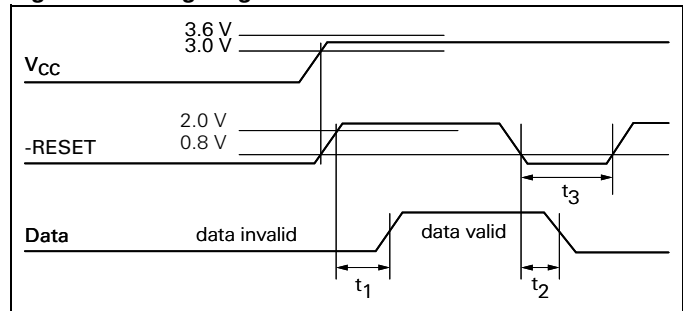
Launched Average Power	$P_{AVG}$	-11.0	-6.0	dBm
Launched Power Shutdown	$P_{SD}$		-30.0	
Center Wavelength	$\lambda_C$	820	860	nm
Spectral Width (FWHM)	$\Delta\lambda$		2	
Relative Intensity Noise	RIN		-116	dB/Hz
Extinction Ratio (dynamic)	ER	5.0		dB

#### Notes

Optical parameters valid for each channel.

- 20%–80% level.
- With input channel-to-channel skew 0 ps and a maximum LVDS channel-to-channel average deviation and swing deviation of 5%.

Figure 2. Timing diagram



Parameter	Symbol	Min.	Max.	Units
-RESET on Delay Time	$t_1$		100	ms
-RESET off Delay Time	$t_2$		50	$\mu$ s
-RESET Low Duration <sup>(1)</sup>	$t_3$	10		$\mu$ s

#### Note

- Only when not used as power on reset. At any failure recovery, -RESET must be brought to low level for at least  $t_3$ .

### Transmitter Pin Description

Pin#	Pin Name	Level/Logic	Description
1	$V_{CC}$		Power supply voltage of laser driver
2	t.b.l.o.		to be left open
3			
4			
5			
6	LA	LVC MOS Out	Laser Active High=normal operation Low=laser fault or -RESET low
7	$V_{EE}$		Ground
8	$V_{EE}$		Ground
9	t.b.l.o.		to be left open
10	t.b.l.o.		to be left open
11	$V_{EE}$		Ground
12	$V_{EE}$		Ground
13	DI01N	LVDS In	Data Input #1, inverted
14	DI01P	LVDS In	Data Input #1, non-inverted

Pin#	Pin Name	Level/Logic	Description
15	V <sub>EE</sub>		Ground
16	V <sub>EE</sub>		Ground
17	DI02N	LVDS In	Data Input #2, inverted
18	DI02P	LVDS In	Data Input #2, non- inverted
19	V <sub>EE</sub>		Ground
20	V <sub>EE</sub>		Ground
21	DI03N	LVDS In	Data Input #3, inverted
22	DI03P	LVDS In	Data Input #3, non- inverted
23	V <sub>EE</sub>		Ground
24	V <sub>EE</sub>		Ground
25	t.b.l.o.		to be left open
26	DI04N	LVDS In	Data Input #4, inverted
27	DI04P	LVDS In	Data Input #4, non- inverted
28	V <sub>EE</sub>		Ground
29	DI05N	LVDS In	Data Input #5, inverted
30	DI05P	LVDS In	Data Input #5, non- inverted
31	V <sub>EE</sub>		Ground
32	V <sub>EE</sub>		Ground
33	DI06N	LVDS In	Data Input #6, inverted
34	DI06P	LVDS In	Data Input #6, non- inverted
35	V <sub>EE</sub>		Ground
36	V <sub>EE</sub>		Ground
37	DI07N	LVDS In	Data Input #7, inverted
38	DI07P	LVDS In	Data Input #7, non- inverted
39	V <sub>EE</sub>		Ground
40	V <sub>EE</sub>		Ground
41	DI08N	LVDS In	Data Input #8, inverted
42	DI08P	LVDS In	Data Input #8, non- inverted
43	V <sub>EE</sub>		Ground
44	V <sub>EE</sub>		Ground
45	V <sub>EE</sub>		Ground
46	DI09N	LVDS In	Data Input #9, inverted
47	DI09P	LVDS In	Data Input #9, non- inverted
48	t.b.l.o.		to be left open
49	V <sub>EE</sub>		Ground
50	V <sub>EE</sub>		Ground
51	DI10N	LVDS In	Data Input #10, inverted
52	DI10P	LVDS In	Data Input #10, non- inverted
53	V <sub>EE</sub>		Ground
54	V <sub>EE</sub>		Ground
55	DI11N	LVDS In	Data Input #11, inverted
56	DI11P	LVDS In	Data Input #11, non- inverted
57	V <sub>EE</sub>		Ground
58	V <sub>EE</sub>		Ground
59	DI12N	LVDS In	Data Input #12, inverted
60	DI12P	LVDS In	Data Input #12, non- inverted

Pin#	Pin Name	Level/Logic	Description
61	V <sub>EE</sub>		Ground
62	V <sub>EE</sub>		Ground
63	t.b.l.o.		to be left open
64	-RESET	LVC MOS In	High=laser diode array is active Low=switches laser diode array off This input has an internal pull-down resistor to ensure laser safety switch off in case of unconnected -RESET input
65	V <sub>EE</sub>		Ground
66	V <sub>EE</sub>		Ground
67	LE	LVC MOS In	Laser ENABLE. High active. High=laser array is on if -LE is also active. Low=laser array is off. This input can be used for connection with an Open Fiber Control (OFC) circuit to enable IEC class 1 links. Has an internal pull-up, therefore can be left open.
68	-LE		Laser ENABLE. Low active. Low=laser array is on if LE is also active. This input can be used for connection with an Open Fiber Control (OFC) circuit to enable IEC class 1 links. Has an internal pull-down, therefore can be left open.
69	t.b.l.o.		to be left open
70	t.b.l.o.		to be left open
71	t.b.l.o.		to be left open
72	V <sub>CC</sub>		Power supply voltage of laser driver

## DESCRIPTION

### Receiver V23815-U1306-M130

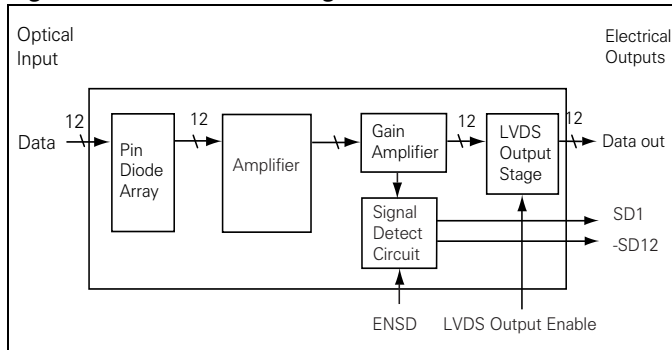
The PAROLI receiver module converts parallel optical input signals into parallel electrical output signals. The optical signals received are converted into voltage signals by PIN diodes, transimpedance amplifiers, and gain amplifiers. All output data signals are Low Voltage Differential Signals (LVDS). The data rate is 250-1600 Mbit/s for each channel. Optical input data should be DC balanced within 144 bits. The maximum time interval of consecutive 0's and 1's (run length) should not exceed 72 bits. This will ensure that the output jitter values given for the transmitter and receiver in this data sheet will be met. Otherwise, jitter values might be exceeded.

Additional Signal Detect outputs (SD1 active high / SD12 active low) show whether an optical AC input signal is present at data input 1 and/or 12. The signal detect circuit can be disabled with a logic low at ENSD. The disabled signal detect circuit will permanently generate an active level at Signal Detect outputs, even if there is insufficient signal input. This could be used for test purposes.

A logic low at LVDS Output Enable sets all data outputs to logic low. SD outputs will not be effected.

All nondata signals have LVCMOS levels. Transmission delay of the PAROLI system is at a maximum 1  $\mu$ s for the transmitter, 1  $\mu$ s for the receiver and approximately 5 ns per meter for the fiber optic cable.

**Figure 3. Receiver block diagram**



## TECHNICAL DATA

### Recommended Operating Conditions

Parameter	Symbol	Min	Max	Units
Power Supply Voltage	$V_{CC}$	3.0	3.6	V
Noise on Power Supply <sup>(1)</sup>	$N_{PS1}$		10	mV
Noise on Power Supply <sup>(2)</sup>	$N_{PS2}$		100	
Differential LVDS Termination Impedance	$R_t$	80	120	$\Omega$
LVC MOS Input High Voltage	$V_{LVCMOSIH}$	2.0	$V_{CC}$	V
LVC MOS Input Low Voltage	$V_{LVCMOSIL}$	$V_{EE}$	0.8	
LVC MOS Input Rise/Fall Time <sup>(3)</sup>	$t_R, t_F$		20	ns
Optical Input Rise/Fall Time <sup>(4)</sup>	$t_R, t_F$		400	ps
Input Extinction Ratio	ER	5.0		dB
Input Center Wavelength	$\lambda_C$	820	860	nm

### Notes

Voltages refer to  $V_{EE}=0$  V.

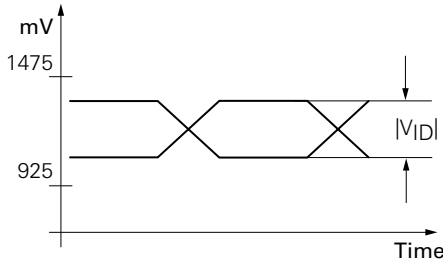
- Noise frequency: 1 kHz to 1 MHz.
- Noise frequency: 1 MHz to 1 GHz.
- Measured between 0.8 V and 2.0 V.
- 20%–80% level.

### Receiver Electro-Optical Characteristics

Parameter	Symbol	Min.	Typ.	Max.	Units
Supply Current	$I_{CC}$		250	350	mA
Power Consumption	P		0.8	1.3	W
LVDS Output Low Voltage <sup>(1,4)</sup>	$V_{LVDSOL}$	925			mV
LVDS Output High Voltage <sup>(1,4)</sup>	$V_{LVDSOH}$			1475	
LVDS Output Differential Voltage <sup>(1, 2, 4)</sup>	$ V_{OD} $	250		400	
LVDS Output Offset Voltage <sup>(1, 3, 4)</sup>	$V_{OS}$	1125		1275	
LVDS Rise/Fall Time <sup>(5)</sup>	$t_R, t_F$			400	ps
LVC MOS Output Voltage Low	$I_{LVCMOSOL}$			400	mV
LVC MOS Output Voltage High	$I_{LVCMOSOH}$	2500			
LVC MOS Input Current High/Low	$I_{LVCMOSI}$	-500		500	$\mu$ A
LVC MOS Output <sup>(8)</sup> Current High	$I_{LVCMOSOH}$			0.5	mA
LVC MOS Output <sup>(9)</sup> Current Low	$I_{LVCMOSOL}$			4.0	
Random Jitter <sup>(6, 7)</sup> ( $14\sigma$ )	$J_R$			0.31	UI
Deterministic Jitter <sup>(6)</sup>	$J_D$			0.08	
Channel-to-channel skew <sup>(10)</sup>	$t_{CSK}$			75	ps

## Notes

1. Level Diagram:



- $|V_{OD}| = |(\text{output voltage of non-inverted output minus output voltage of inverted output})|$ .
- $V_{OS} = 1/2$  (output voltage of inverted output + output voltage of non-inverted output).
- LVDS output must be terminated differentially with  $R_t$ .
- Measured between 20% and 80% level with a maximum capacitive load of 5 pF.
- With no optical input jitter.
- At sensitivity limit of -17.0 dBm at infinite ER.
- Source current
- Sink current
- With input channel-to-channel skew 0 ps.

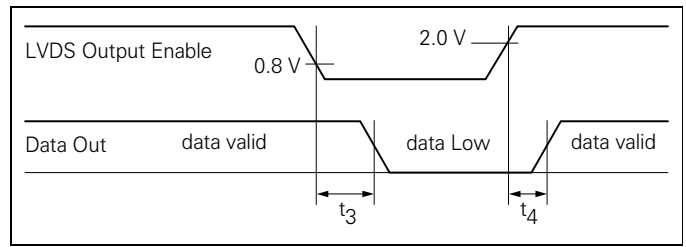
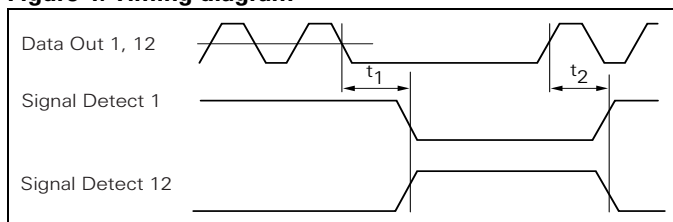
Parameter	Symbol	Min.	Typ.	Max.	Units
Data Rate Per Channel <sup>(1)</sup>	$D_R$	250		1600	Mbit/s
Sensitivity (Average Power) <sup>(2)</sup>	$P_{IN}$			-17.0	dBm
Saturation (Average Power) <sup>(2)</sup>	$P_{SAT}$	-6.0			
Signal Detect Assert Level <sup>(3)</sup>	$P_{SDA}$			-18.0	
Signal Detect Deassert Level <sup>(3)</sup>	$P_{SDD}$	-26.0			
Signal Detect Hysteresis <sup>(3)</sup>	$P_{SDA} - P_{SDD}$	1.0	2.5	4.0	dB
Return Loss of Receiver	$A_{RL}$	12			

## Notes

Optical parameters valid for each channel.

- Optical input data should be DC balanced within 100 ns. Maximum time interval of consecutive '0's and '1's (run length) should not exceed 50 ns.
- Measured with a DC balanced pattern (within 144 bits) with a maximum run length of 72 bits. BER=10<sup>-12</sup>. Extinction ratio=infinite.
- $P_{SDA}$ : Average optical power when SD switches from unactive to active.  
 $P_{SDD}$ : Average optical power when SD switches from active to unactive.

**Figure 4. Timing diagram**



Parameter	Symbol	Max.	Units
Signal Detect Deassert Time	$t_1$	10	$\mu\text{s}$
Signal Detect Assert Time	$t_2$		
LVDS Output Enable off Delay Time	$t_3$	20	ns
LVDS Output Enable on Delay Time	$t_4$		

## Receiver Pin Description

Pin#	Pin Name	Level/Logic	Description
1	$V_{EE}$		Ground
2	$V_{CC1}$		Power supply voltage of preamplifier
3	$V_{CC2}$		Power supply voltage of analog circuitry
4	t.b.l.o.		to be left open
5	-RESET	LVC MOS In	High=normal operation Low=sets all Data Outputs to low This input has an internal pull-up resistor which pulls to high level when this input is left open
6	SD1	LVC MOS Out	Signal Detect on fiber #1. High=sufficient AC power is present on fiber #1 Low=signal on fiber #1 is insufficient
7	$V_{CC3}$		Power supply voltage of digital circuitry
8	$V_{EE}$		Ground
9	t.b.l.o.		to be left open
10	$V_{EE}$		Ground
11	$V_{EE}$		Ground
12	$V_{EE}$		Ground
13	DO01P	LVDS Out	Data Output #1, non-inverted
14	DO01N	LVDS Out	Data Output #1, inverted
15	$V_{EE}$		Ground
16	$V_{EE}$		Ground
17	DO02P	LVDS Out	Data Output #2, non-inverted
18	DO02N	LVDS Out	Data Output #2, inverted
19	$V_{EE}$		Ground
20	$V_{EE}$		Ground
21	DO03P	LVDS Out	Data Output #3, non-inverted
22	DO03N	LVDS Out	Data Output #3, inverted

Pin#	Pin Name	Level/Logic	Description
23	V <sub>EE</sub>		Ground
24	V <sub>EE</sub>		Ground
25	t.b.l.o.		to be left open
26	DO04P	LVDS Out	Data Output #4, non-inverted
27	DO04N	LVDS Out	Data Output #4, inverted
28	V <sub>EE</sub>		Ground
29	DO05P	LVDS Out	Data Output #5, non-inverted
30	DO05N	LVDS Out	Data Output #5, inverted
31	V <sub>EE</sub>		Ground
32	V <sub>EE</sub>		Ground
33	DO06P	LVDS Out	Data Output #6, non-inverted
34	DO06N	LVDS Out	Data Output #6, inverted
35	V <sub>EE</sub>		Ground
36	V <sub>EE</sub>		Ground
37	DO07P	LVDS Out	Data Output #7, non-inverted
38	DO07N	LVDS Out	Data Output #7, inverted
39	V <sub>EE</sub>		Ground
40	V <sub>EE</sub>		Ground
41	DO08P	LVDS Out	Data Output #8, non-inverted
42	DO08N	LVDS Out	Data Output #8, inverted
43	V <sub>EE</sub>		Ground
44	V <sub>EE</sub>		Ground
45	V <sub>EE</sub>		Ground
46	DO09P	LVDS Out	Data Output #9, non-inverted
47	DO09N	LVDS Out	Data Output #9, inverted
48	t.b.l.o.		to be left open
49	V <sub>EE</sub>		Ground
50	V <sub>EE</sub>		Ground
51	DO10P	LVDS Out	Data Output #10, non-inverted
52	DO10N	LVDS Out	Data Output #10, inverted
53	V <sub>EE</sub>		Ground
54	V <sub>EE</sub>		Ground
55	DO11P	LVDS Out	Data Output #11, non-inverted
56	DO11N	LVDS Out	Data Output #11, inverted
57	V <sub>EE</sub>		Ground
58	V <sub>EE</sub>		Ground
59	DO12P	LVDS Out	Data Output #12, non-inverted
60	DO12N	LVDS Out	Data Output #12, inverted
61	V <sub>EE</sub>		Ground
62	V <sub>EE</sub>		Ground
63	V <sub>EE</sub>		Ground
64	t.b.l.o.		to be left open
65	V <sub>EE</sub>		Ground
66	V <sub>CC3</sub>		Power supply voltage of digital circuitry

Pin#	Pin Name	Level/Logic	Description
67	-SD12	LVC MOS Out low active	Signal Detect on fiber #12 Low=signal of sufficient AC power is present on fiber #12 High=signal on fiber #12 is insufficient
68	ENSD	LVC MOS In	High=SD1 and SD12 function enabled Low=SD1 and SD12 are set to permanent active. Internal pull-up pulls to high level when input is left open.
69	t.b.l.o.		to be left open
70	V <sub>CC2</sub>		Power supply voltage of LVDS outputs
71	V <sub>CC1</sub>		Power supply voltage of amplifier
72	V <sub>EE</sub>		Ground

### Optical Port

Designed for Infineon Simplex MT Connector (SMC)

- Port outside dimensions: 15.4 mm x 6.8 mm (width x height)
- MT compatible fiber spacing (250 μm) and alignment pin spacing (4600 μm)
- Alignment pins fixed in module port
- Integrated mechanical keying
- process plug (SMC dimensions) included with every module
- cleaning of port and connector interfaces necessary prior to mating

### Features of Infineon Simplex MT Connector (SMC)

(as part of optional PAROLI fiber optic cables)

- Uses standardized MT ferrule
- MT compatible fiber spacing (250 μm) and alignment pin spacing (4600 μm)
- Snap-in mechanism
- Ferrule bearing spring loaded
- Not strain-relieved
- Integrated mechanical keying

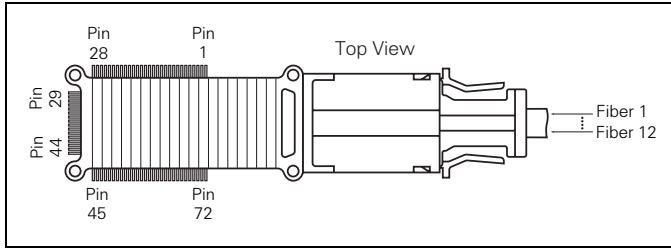
### Cleaning and Soldering Process for Transmitter and Receiver

Special care must be taken to remove residuals from the soldering and washing process, which can impact the mechanical function. Avoid the use of aggressive organic solvents like ketones, ethers, etc. Consult the supplier of the PAROLI modules and the supplier of the solder paste and flux for recommended cleaning solvents.

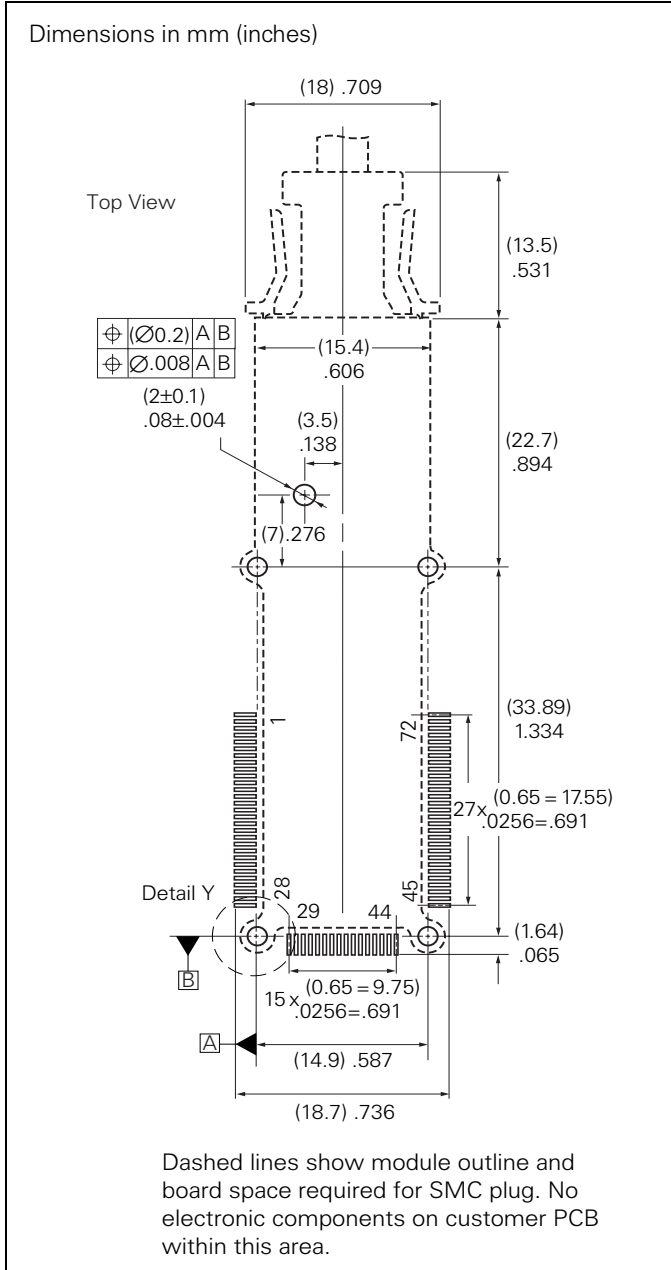
The following common cleaning solvents will not affect the module: deionized water, ethanol, and isopropyl alcohol. Air-drying is recommended to a maximum temperature of 100°C. Do not use ultrasonics.

During soldering, heat must be applied to the leads only, to ensure that the case temperature never exceeds 100°C. The module must be mounted with a hot-bar soldering process using a SnPb solder type, e.g.. S-Sn63Pb37E, in accordance with ISO 9435.

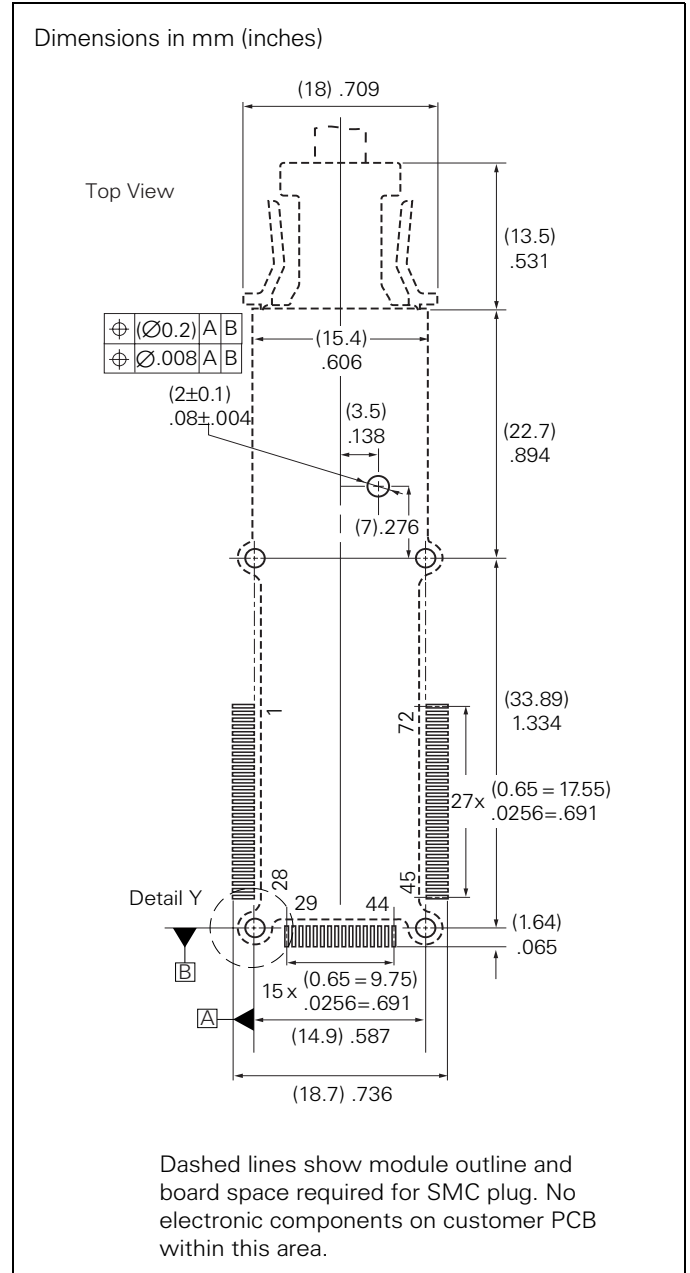
**Figure 5. Numbering convention**



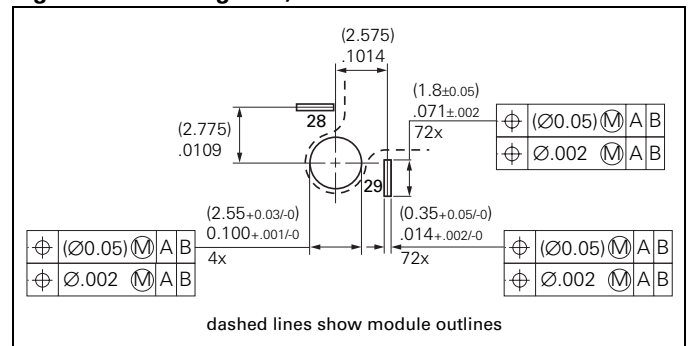
**Figure 6. Recommended footprint: receiver**



**Figure 7. Recommended footprint: transmitter**

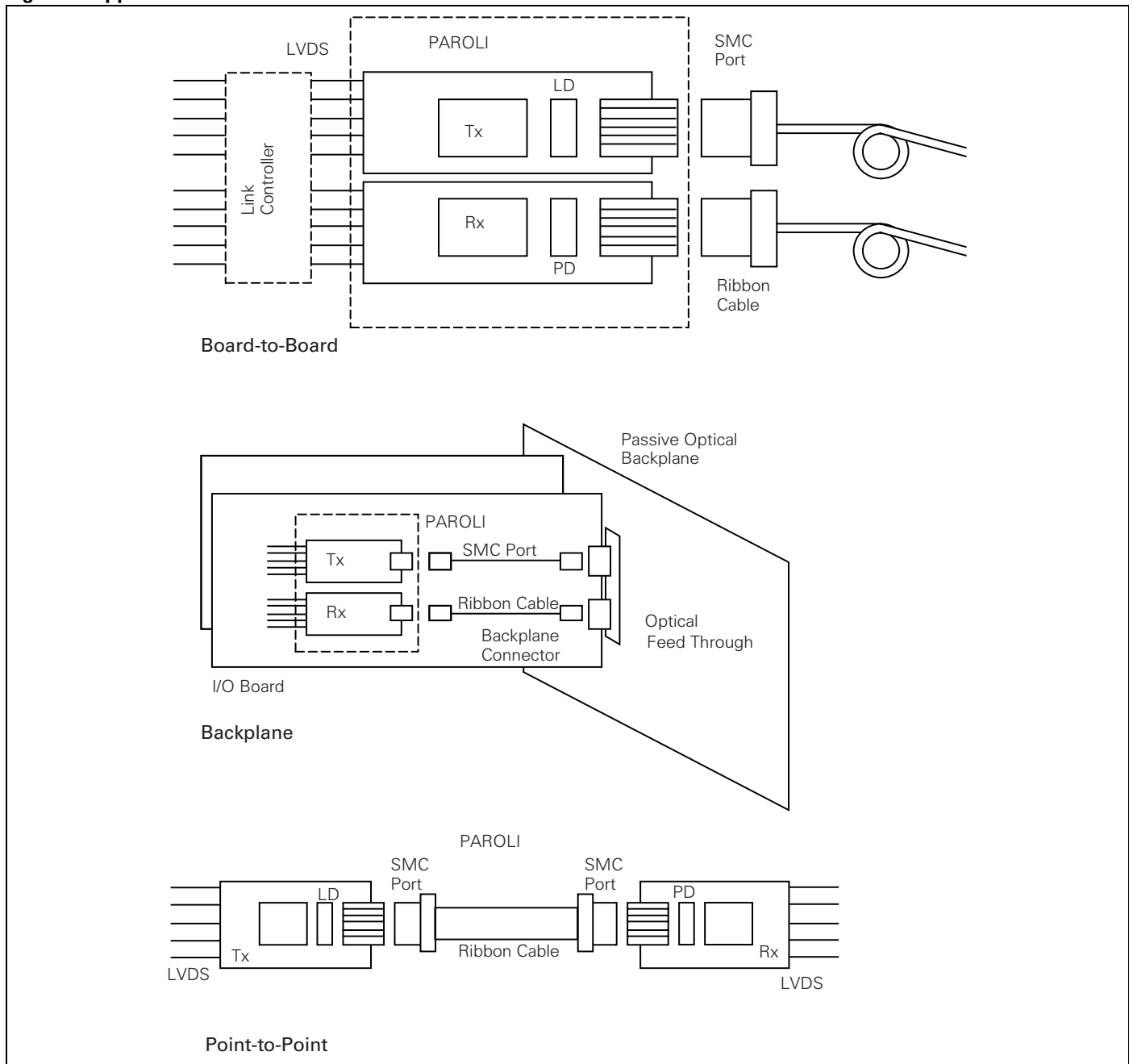


**Figure 8. Mounting hole, Detail Y**





**Figure 9. Applications**



Published by Infineon Technologies AG

© Infineon Technologies AG 1999  
All Rights Reserved

**Attention please!**

The information herein is given to describe certain components and shall not be considered as warranted characteristics.  
Terms of delivery and rights to technical change reserved.  
We hereby disclaim any and all warranties, including but not limited to warranties of non-infringement, regarding circuits, descriptions and charts stated herein.  
Infineon Technologies is an approved CECC manufacturer.

**Information**

For further information on technology, delivery terms and conditions and prices please contact the Infineon Technologies offices or our Infineon Technologies Representatives worldwide - see our webpage at [www.infineon.com/fiberoptics](http://www.infineon.com/fiberoptics)

**Warnings**

Due to technical requirements components may contain dangerous substances. For information on the types in question please contact your Infineon Technologies offices.  
Infineon Technologies Components may only be used in life-support devices or systems with the express written approval of Infineon Technologies, if a failure of such components can reasonably be expected to cause the failure of that life-support device or system, or to affect the safety or effectiveness of that device or system. Life support devices or systems are intended to be implanted in the human body, or to support and/or maintain and sustain and/or protect human life. If they fail, it is reasonable to assume that the health of the user or other persons may be endangered.