

Features

- Replaces mechanical relays
- High-performance, low-cost solution for switching between different LAN signals
- Ultra-low quiescent power (0.1µA typical)
- Low crosstalk: -90dB @ 30 MHz
- Low insertion loss or on-resistance: 3Ω typical
- Single supply operation: 3.3V
- Off isolation: -45dB @ 30 MHz
- Wide bandwidth data rates > 200 MHz
- Packages available:
 - 16-pin 150 mil wide plastic QSOP (Q)
 - 16-pin 173 mil wide plastic TSSOP (L)

Description

Pericom Semiconductor's PI3L series of logic circuits are produced using the Company's advanced submicron CMOS technology.

The PI3L100 is a Quad 2:1 multiplexer/demultiplexer LanSwitch with three-state outputs. This device can be used for switching between various standards, such as 10 Base-T and 100 Base-T. Generally, this part can be used to replace mechanical relays in low voltage LAN applications that have physical layer, unshielded twisted pair media (UTP) with either CAT 3 or CAT 5 grade cable.

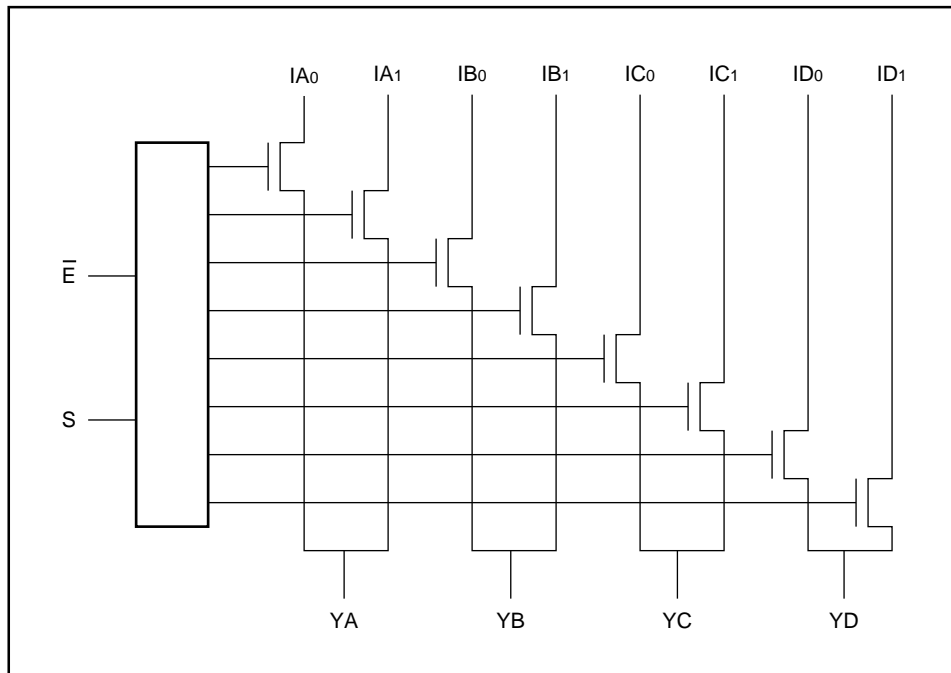
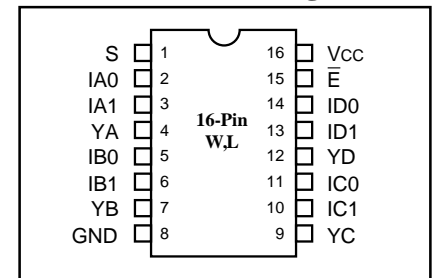
Logic Block Diagram

16-Pin Product Configuration

Product Pin Description

| Pin Name | Description |
|----------------------------------|---------------|
| IA _n -ID _n | Data Inputs |
| S | Select Inputs |
| E-bar | Enable |
| YA-YD | Data Outputs |
| GND | Ground |
| Vcc | Power |

Truth Table⁽¹⁾

| E-bar | S | YA | YB | YC | YD | Function |
|-------|---|------|------|------|------|----------|
| H | X | Hi-Z | Hi-Z | Hi-Z | Hi-Z | Disable |
| L | L | IA0 | IB0 | IC0 | ID0 | S = 0 |
| L | H | IA1 | IB1 | IC1 | ID1 | S = 1 |

Note:

1. H = High Voltage Level
L = Low Voltage Level

Maximum Ratings

(Above which the useful life may be impaired. For user guidelines, not tested.)

| | |
|--|-----------------|
| Storage Temperature | -65°C to +150°C |
| Ambient Temperature with Power Applied | 0°C to +70°C |
| Supply Voltage to Ground Potential (Inputs & V _{CC} Only) | -0.5V to +4.6V |
| Supply Voltage to Ground Potential (Outputs & D/O Only) ... | -0.5V to +4.6V |
| DC Input Voltage | -0.5V to +4.6V |
| DC Output Current | 120 mA |
| Power Dissipation | 0.5W |

Note:

Stresses greater than those listed under MAXIMUM RATINGS may cause permanent damage to the device. This is a stress rating only and functional operation of the device at these or any other conditions above those indicated in the operational sections of this specification is not implied. Exposure to absolute maximum rating conditions for extended periods may affect reliability.

DC Electrical Characteristics (Over the Operating Range, T_A = 0°C to +70°C, V_{CC} = 3.3V ±5%)

| Parameters | Description | Test Conditions(1) | Min. | Typ ⁽²⁾ | Max. | Units |
|---------------------|--------------------------------------|--|------|--------------------|------|-------|
| V _{IH} | Input HIGH Voltage | Guaranteed Logic HIGH Level | 2.0 | — | — | V |
| V _{IL} | Input LOW Voltage | Guaranteed Logic LOW Level | -0.5 | — | 0.8 | |
| I _{IH} | Input HIGH Current | V _{CC} = Max., V _{IN} = V _{CC} | — | — | ±1 | μA |
| I _{IL} | Input LOW Current | V _{CC} = Max., V _{IN} = GND | — | — | ±1 | |
| I _{OZH} | High Impedance Output Current | 0 ≤ A, B ≤ V _{CC} | — | — | ±1 | |
| V _{IK} | Clamp Diode Voltage | V _{CC} = Min., I _{IN} = -18mA | — | — | -1.2 | V |
| I _{OS} | Short Circuit Current ⁽³⁾ | A (B) = 0V, B (A) = V _{CC} | 100 | — | — | mA |
| V _H | Input Hysteresis at Control Pins | | — | 150 | — | mV |
| R _{ON} (6) | Switch On Resistance | V _{CC} = Min., V _{IN} = 0V, I _{ON} = 48mA | — | 5 | 7 | Ω |
| | | V _{CC} = Min., V _{IN} = 2.4V, I _{ON} = 15mA | — | 10 | 15 | |
| ΔR _{ON} | On Resistance Match | V _{IN} = 3.0V, E = LOW | — | — | — | |

Notes:

1. For Max. or Min. conditions, use appropriate value specified under Electrical Characteristics for applicable device type.
2. Typical values are at V_{CC} = 3.3V, T_A = 25°C ambient temperature.
3. Not more than one output should be shorted at one time. Duration of the test should not exceed one second.
4. V_{ON} (min) value is at V_{CC} = 3.3V, T_A = 70°C.

Capacitance (T_A = 25°C, f = 1 MHz)

| Parameters ⁽¹⁾ | Description | Test Conditions | Typ | Max. | Units |
|---------------------------|-------------------------------|----------------------|-----|------|-------|
| C _{IN} | Input Capacitance | V _{IN} = 0V | | 3 | pF |
| C _{OFF} | Capacitance, Switch Off (Y) | V _{IN} = 0V | | 17 | pF |
| C _{ON} | Capacitance, Switch On | V _{IN} = 0V | | 25 | pF |
| C _{OFF} | Capacitance, Switch Off (A/B) | V _{IN} = 0V | | 8 | pF |

Note:

1. This parameter is determined by device characterization but is not production tested.

Power Supply Characteristics

| Parameters | Description | Test Conditions ⁽¹⁾ | | Min. | Typ ⁽²⁾ | Max. | Units |
|------------------|---|---|---|------|--------------------|------|------------|
| I _{CC} | Quiescent Power Supply Current | V _{CC} =Max. | V _{IN} =GND or V _{CC} | — | 0.1 | 3.0 | μA |
| ΔI _{CC} | Supply Current per Input @ TTL HIGH | V _{CC} =Max. | V _{IN} =3.4V ⁽³⁾ | — | — | 750 | μA |
| I _{CCD} | Supply Current per Input per MHz ⁽⁴⁾ | V _{CC} =Max., Input Pins Open E̅=GND Control Input Toggling 50% Duty Cycle | | — | — | 0.25 | mA/ MHz |

Notes:

1. For Max. or Min. conditions, use appropriate value specified under Electrical Characteristics for the applicable device.
2. Typical values are at V_{CC} = 3.3V, +25°C ambient.
3. Per TTL driven input (V_{IN} = 3.0V, control inputs only); A and B pins do not contribute to I_{CC}.
4. This current applies to the control inputs only and represent the current required to switch internal capacitance at the specified frequency. The A and B inputs generate no significant AC or DC currents as they transition. This parameter is not tested, but is guaranteed by design.

Switching Characteristics over Operating Range

| Parameters | Description | Conditions ⁽¹⁾ | PI3L100 | | | Unit |
|--------------------------------------|---|---|---------|-----|------|------|
| | | | Com. | | | |
| | | | Min | Typ | Max | |
| t _{PLH} | Propagation Delay ^(2,3) In to Y | C _L = 50pF R _L = 500Ω | — | — | 0.25 | ns |
| t _{SY} | Bus Enable Time S to Y | | 1 | — | 4.5 | ns |
| t _{PHZ} t _{PLZ} | Bus Disable Time E̅ to Y | | 1 | — | 4.5 | ns |
| X _{TALK} | Crosstalk | R _L = 100Ω f = 30 MHz See Figure 2 | — | -90 | — | dB |
| O _{IRR} | Off Isolation | R _L = 100Ω f = 30 MHz | — | -45 | — | dB |
| B _W | -3dB Bandwidth | R _L = 100Ω See Figure 2 | — | 213 | — | MHz |
| t _{ON} | Turn On Time | R _L = 100Ω | — | — | — | ns |
| t _{OFF} | Turn Off Time | C _L = 35pF See Figure 1 | — | — | — | ns |

Notes:

1. See test circuit and waveforms.
2. This parameter is guaranteed but not tested.
3. The bus switch contributes no propagational delay other than the RC delay of the ON resistance of the switch and the load capacitance. The time constant for the switch alone is of the order of 0.25ns for 50pF load. Since this time constant is much smaller than the rise/fall times of typical driving signals, it adds very little propagational delay to the system. Propagational delay of the bus switch when used in a system is determined by the driving circuit on the driving side of the switch and its interaction with the load on the driven side.

Applications

LAN Switch

The PI3L100 was designed to switch between various standards such as 10Base-T, 100Base-T, 100VG-AnyLAN, and Token Ring. Also general purpose applications such as loopback, line termination, and line clamps that might normally use mechanical relays are also ideal uses for this LAN Switch (see Figure 1). Generally speaking, this LAN Switch can be used for data rates to 200 Mbps and data signal levels from 0V to 3.6V.

| LAN Standards | Data Rate per twisted pair (UTP) |
|---------------|----------------------------------|
| 10Base-T | 10 Mbps |
| 100Base-T | 100 Mbps |
| 100VG-AnyLAN | 25 Mbps |

V_{CC} Bias Voltage vs. R_{ON}

To keep R_{ON} to a minimum, it is recommended that the V_{CC} voltage be increased to a voltage between 3.3V and 3.6V. Ideally an input voltage between 0.2V and 3.6V will keep R_{ON} flat.

Signal Distortion

Distortion of the input signal is equated to 20LOG ΔR_{ON}/R_L. So keeping R_{ON} flat as the data signal level varies is critical to low distortion. It should also be noted that increasing the data rate increases harmonic distortion which also effects the signal amplitude.

Test Circuits

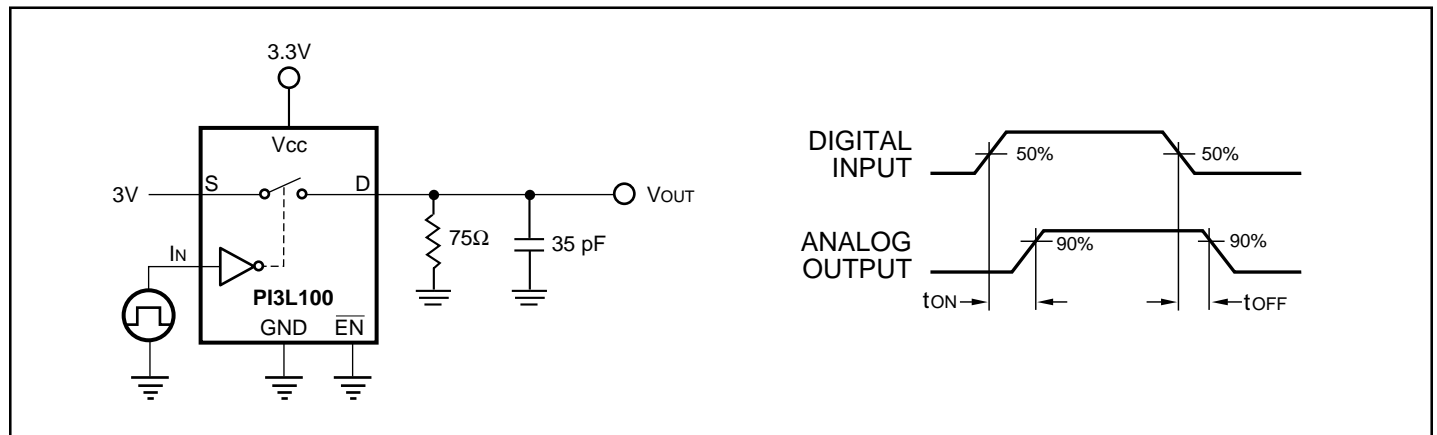

Figure 1. Switching Time

Ordering Information

| Part | Pin | Package | Temperature |
|----------|-----|-----------|----------------|
| PI3L100Q | 16 | QSOP (Q) | -40°C to +85°C |
| PI3L100L | 16 | TSSOP (L) | -40°C to +85°C |

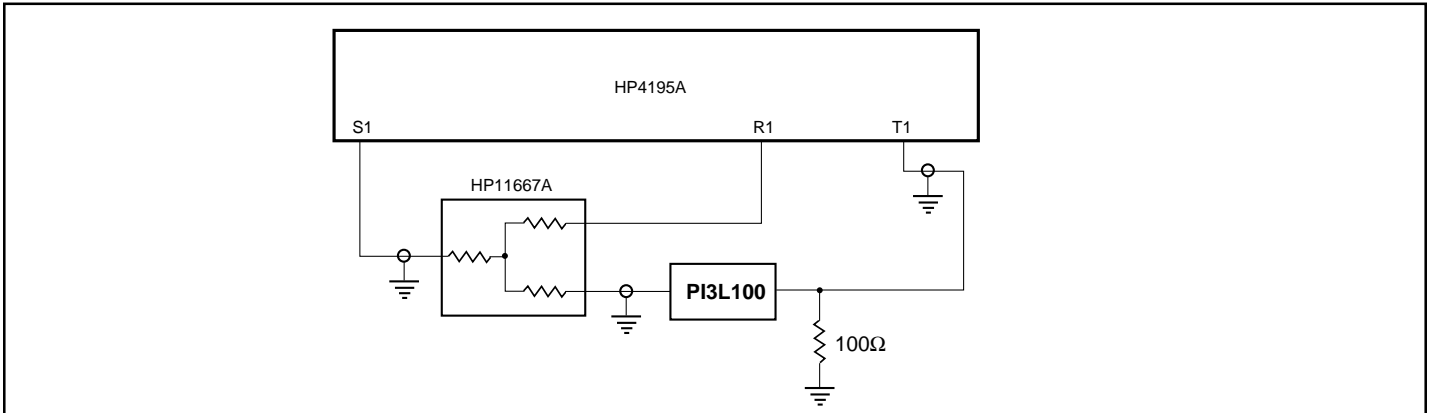

Figure 2. Gain/Phase Crosstalk, Off Isolation

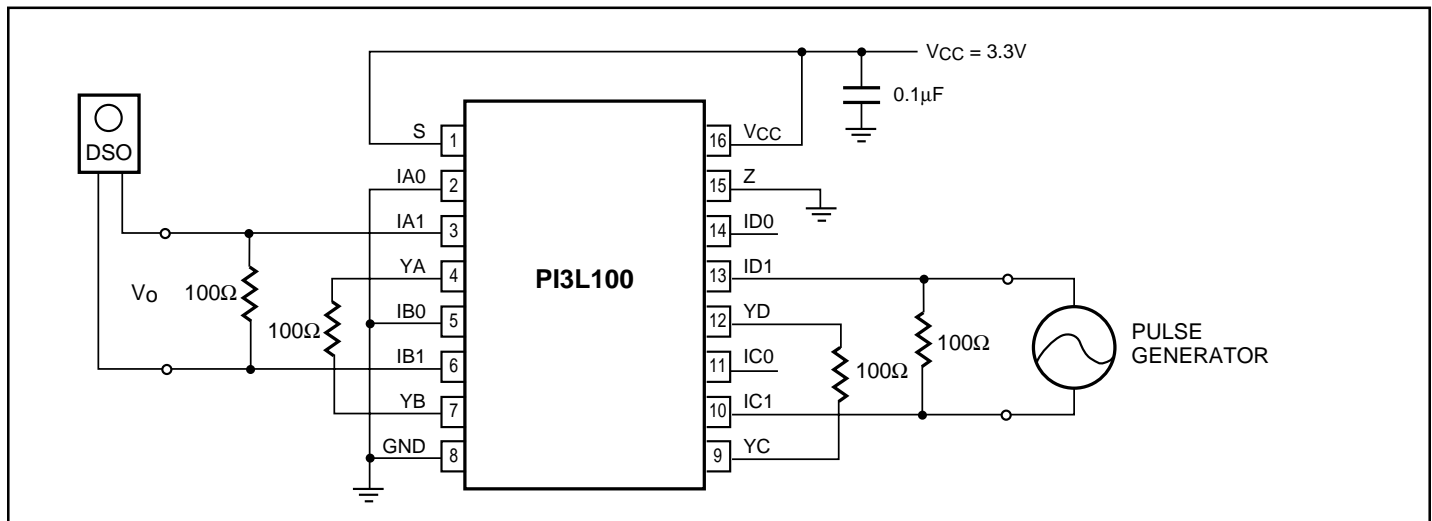

Figure 3. Differential Crosstalk Measurement

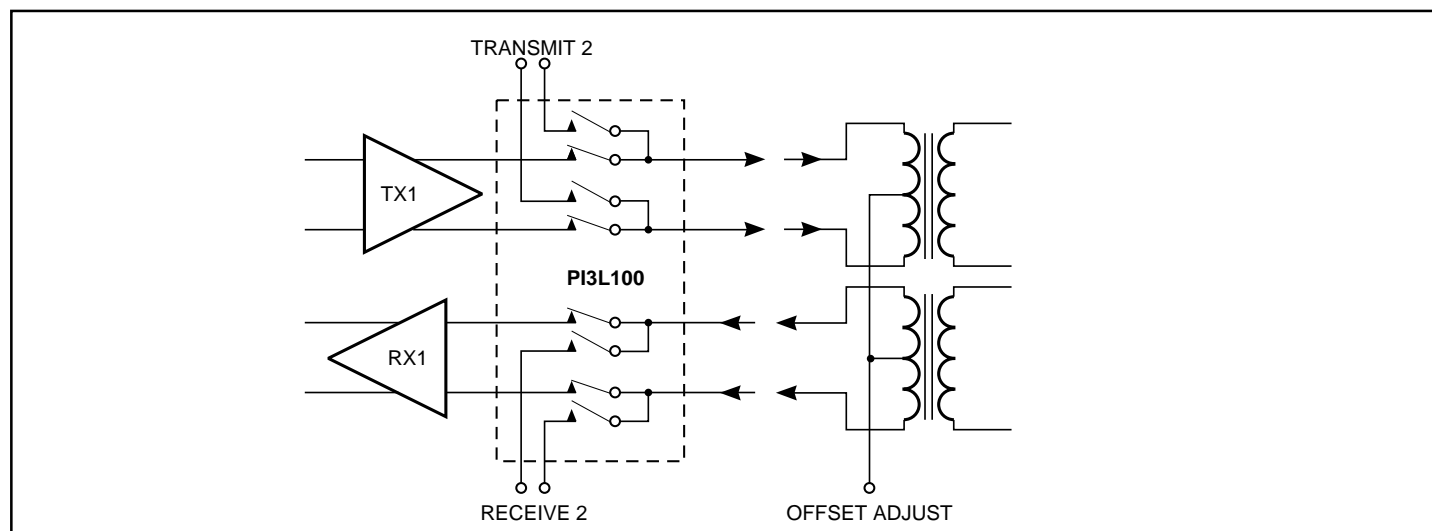
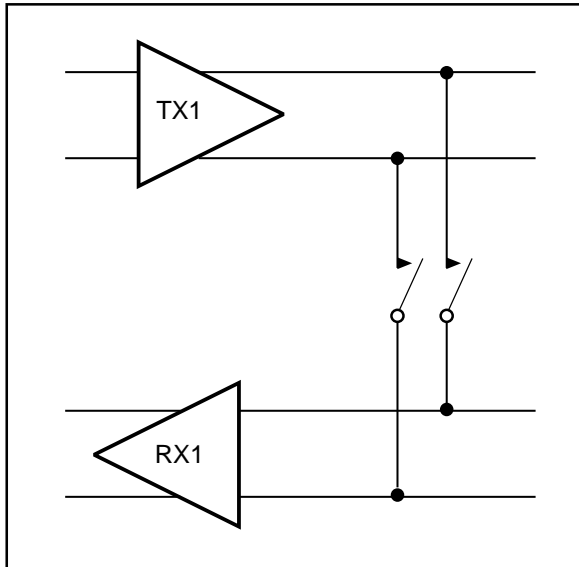
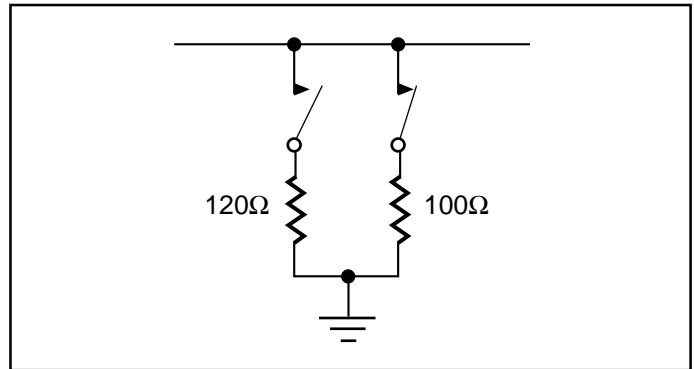
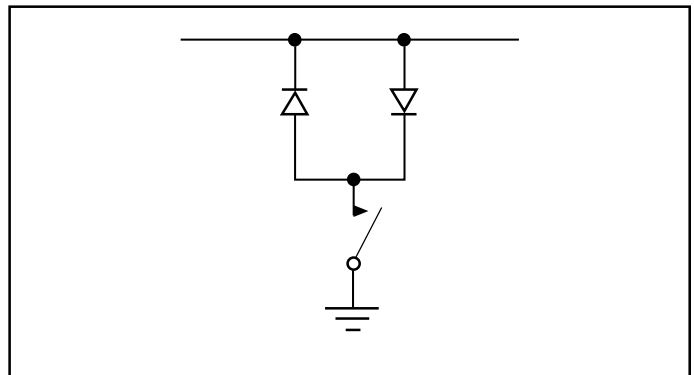

Figure 4a. Full Duplex Transceiver

Figure 4b. Loop Back

Figure 4c. Line Termination

Figure 4d. Line Clamp

LIFESUPPORT POLICY

Pericom Semiconductor Corporation's products are not authorized for use as critical components in life support devices or systems unless a specific written agreement pertaining to such intended use is executed between the manufacturer and an officer of PSC.

1. Life support devices or systems are devices or systems which:
 - (a) are intended for surgical implant into the body, or
 - (b) support or sustain life and whose failure to perform, when properly used in accordance with instructions for use provided in the labeling, can be reasonably expected to result in a significant injury to the user.
2. A critical component is any component of a life support device or system whose failure to perform can be reasonably expected to cause the failure of the life support device or system, or to affect its safety or effectiveness.

Pericom Semiconductor Corporation reserves the right to make changes to its products or specifications at any time, without notice, in order to improve design or performance and to supply the best possible product. Pericom Semiconductor does not assume any responsibility for use of any circuitry described other than the circuitry embodied in a Pericom Semiconductor product. The Company makes no representations that circuitry described herein is free from patent infringement or other rights of third parties which may result from its use. No license is granted by implication or otherwise under any patent, patent rights, or other rights, of Pericom Semiconductor Corporation.