

TC74AC138P, TC74AC138F, TC74AC138FN, TC74AC138FT

3-TO-8 LINE DECODER

The TC74AC138 is an advanced high speed CMOS 3-to-8 LINE DECODER fabricated with silicon gate and double-layer metal wiring C²MOS technology.

It achieves the high speed operation similar to equivalent Bipolar Schottky TTL while maintaining the CMOS low power dissipation.

When the device is enabled, 3 Binary Select inputs (A, B and C) determine which one of the outputs ($\bar{Y}0 - \bar{Y}7$) will go low.

When enable input G1 is held low or either $\bar{G}2A$ or $\bar{G}2B$ is held high, decoding function is inhibited and all outputs go high.

G1, $\bar{G}2A$, and $\bar{G}2B$ inputs are provided to ease cascade connection and for use as an address decoder for memory systems.

All inputs are equipped with protection circuits against static discharge or transient excess voltage.

FEATURES :

- High Speed..... $t_{pd} = 5.9ns$ (typ.) at $V_{CC} = 5V$
- Low Power Dissipation..... $I_{CC} = 8\mu A$ (Max.) at $T_a = 25^\circ C$
- High Noise Immunity..... $V_{NIH} = V_{NIL} = 28\% V_{CC}$ (Min.)
- Symmetrical Output Impedance... $|I_{OH}| = I_{OL} = 24mA$ (Min.)
Capability of driving 50 Ω transmission lines.
- Balanced Propagation Delays... $t_{pLH} \approx t_{pHL}$
- Wide Operating Voltage Range... $V_{CC} (opr) = 2V \sim 5.5V$
- Pin and Function Compatible with 74F138

(Note) The JEDEC SOP (FN) is not available in Japan.

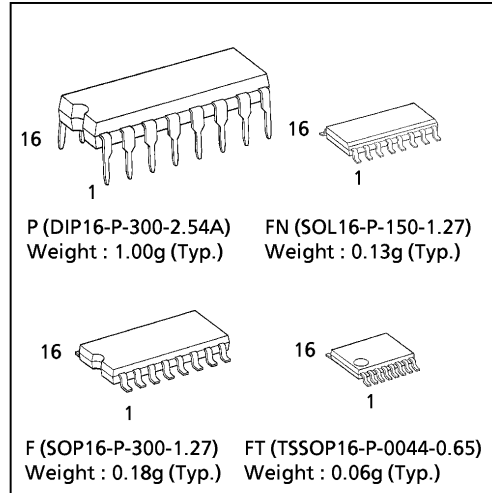

PIN ASSIGNMENT

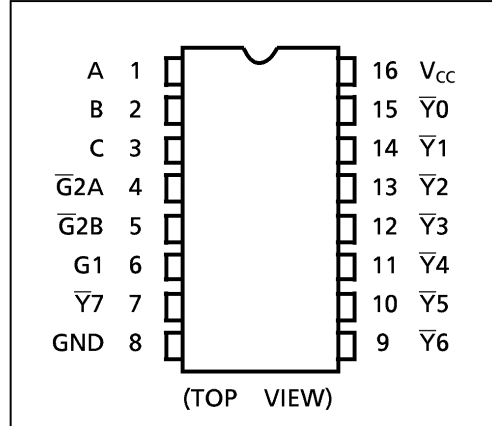

IEC LOGIC SYMBOL

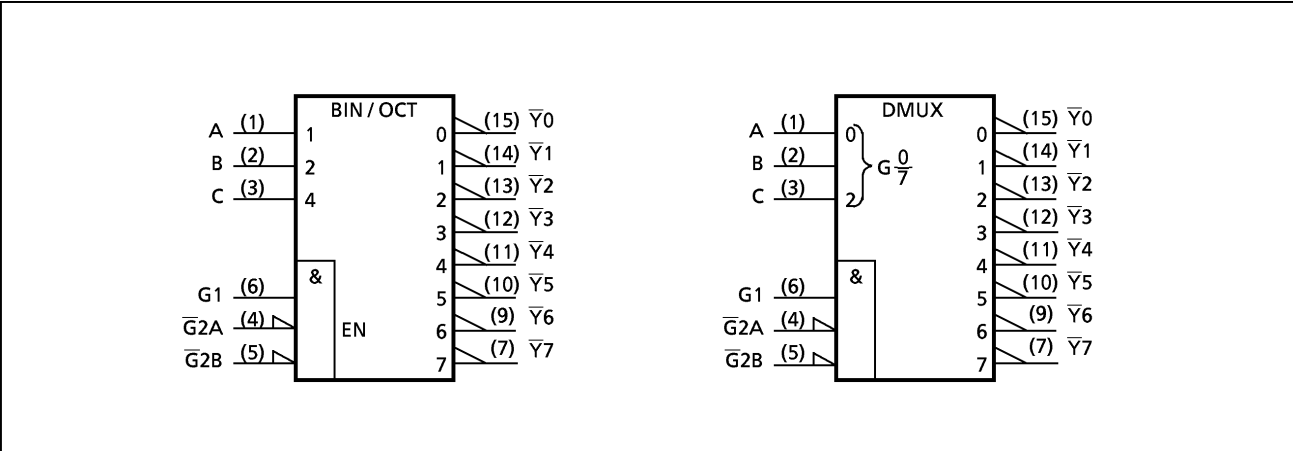

TRUTH TABLE

| INPUTS | | | | | | OUTPUTS | | | | | | | | SELECTED OUTPUT |
|--------|-------------|-------------|--------|---|---|------------|------------|------------|------------|------------|------------|------------|------------|-----------------|
| ENABLE | | | SELECT | | | $\bar{Y}0$ | $\bar{Y}1$ | $\bar{Y}2$ | $\bar{Y}3$ | $\bar{Y}4$ | $\bar{Y}5$ | $\bar{Y}6$ | $\bar{Y}7$ | |
| G1 | $\bar{G}2A$ | $\bar{G}2B$ | C | B | A | | | | | | | | | |
| L | X | X | X | X | X | H | H | H | H | H | H | H | H | NONE |
| X | H | X | X | X | X | H | H | H | H | H | H | H | H | NONE |
| X | X | H | X | X | X | H | H | H | H | H | H | H | H | NONE |
| H | L | L | L | L | L | L | H | H | H | H | H | H | H | $\bar{Y}0$ |
| H | L | L | L | L | H | H | L | H | H | H | H | H | H | $\bar{Y}1$ |
| H | L | L | L | H | L | H | H | L | H | H | H | H | H | $\bar{Y}2$ |
| H | L | L | L | H | H | H | H | L | H | H | H | H | H | $\bar{Y}3$ |
| H | L | L | H | L | L | H | H | H | L | H | H | H | H | $\bar{Y}4$ |
| H | L | L | H | L | H | H | H | H | H | L | H | H | H | $\bar{Y}5$ |
| H | L | L | H | H | L | H | H | H | H | H | L | H | H | $\bar{Y}6$ |
| H | L | L | H | H | H | H | H | H | H | H | H | L | H | $\bar{Y}7$ |

X : Don't Care

LOGIC DIAGRAM

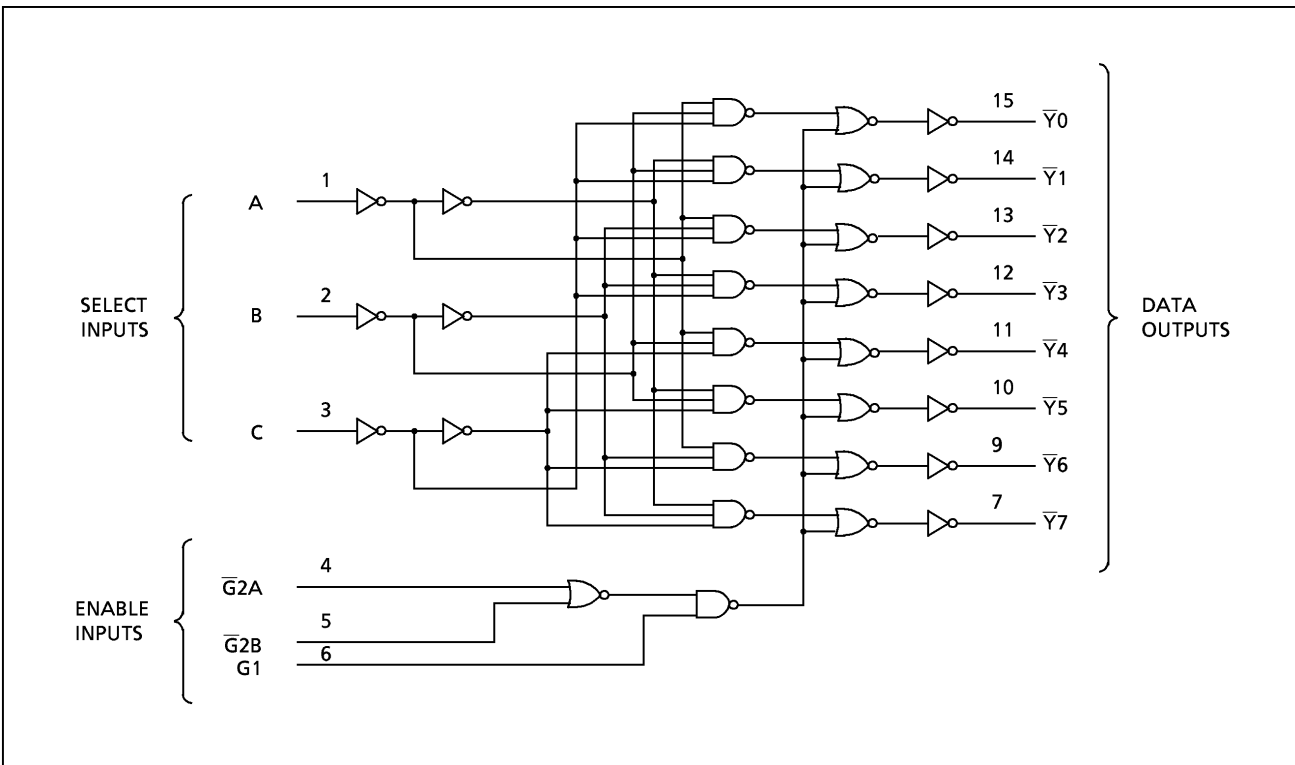

ABSOLUTE MAXIMUM RATINGS

| PARAMETER | SYMBOL | VALUE | UNIT |
|------------------------------------|------------------|------------------------------|------|
| Supply Voltage Range | V _{CC} | -0.5~7.0 | V |
| DC Input Voltage | V _{IN} | -0.5~V _{CC} + 0.5 | V |
| DC Output Voltage | V _{OUT} | -0.5~V _{CC} + 0.5 | V |
| Input Diode Current | I _{IK} | ± 20 | mA |
| Output Diode Current | I _{OK} | ± 50 | mA |
| DC Output Current | I _{OUT} | ± 50 | mA |
| DC V _{CC} /Ground Current | I _{CC} | ± 200 | mA |
| Power Dissipation | P _D | 500 (DIP)* / 180 (SOP/TSSOP) | mW |
| Storage Temperature | T _{stg} | -65~150 | °C |

*500mW in the range of Ta = -40°C~65°C. From Ta = 65°C to 85°C a derating factor of -10mW/°C should be applied up to 300mW.

RECOMMENDED OPERATING CONDITIONS

| PARAMETER | SYMBOL | VALUE | UNIT |
|--------------------------|------------------|---|--------|
| Supply Voltage | V _{CC} | 2.0~5.5 | V |
| Input Voltage | V _{IN} | 0~V _{CC} | V |
| Output Voltage | V _{OUT} | 0~V _{CC} | V |
| Operating Temperature | T _{opr} | -40~85 | °C |
| Input Rise and Fall Time | dt / dV | 0~ 100 (V _{CC} = 3.3 ± 0.3V) 0~ 20 (V _{CC} = 5 ± 0.5V) | ns / V |

DC ELECTRICAL CHARACTERISTICS

| PARAMETER | SYMBOL | TEST CONDITION | V _{CC} (V) | Ta = 25°C | | | Ta = -40~85°C | | UNIT | |
|-----------------------------|-----------------|---|---|-----------|------|-------|---------------|-------|------|---|
| | | | | MIN. | TYP. | MAX. | MIN. | MAX. | | |
| High - Level Input Voltage | V _{IH} | | 2.0 | 1.50 | — | — | 1.50 | — | V | |
| | | | 3.0 | 2.10 | — | — | 2.10 | — | | |
| | | | 5.5 | 3.85 | — | — | 3.85 | — | | |
| Low - Level Input Voltage | V _{IL} | | 2.0 | — | — | 0.50 | — | 0.50 | V | |
| | | | 3.0 | — | — | 0.90 | — | 0.90 | | |
| | | | 5.5 | — | — | 1.65 | — | 1.65 | | |
| High - Level Output Voltage | V _{OH} | V _{IN} = V _{IH} or V _{IL} | I _{OH} = -50μA | 2.0 | 1.9 | 2.0 | — | 1.9 | — | V |
| | | | | 3.0 | 2.9 | 3.0 | — | 2.9 | — | |
| | | | | 4.5 | 4.4 | 4.5 | — | 4.4 | — | |
| | | | I _{OH} = -4mA I _{OH} = -24mA I _{OH} = -75mA* | 3.0 | 2.58 | — | — | 2.48 | — | |
| | | | | 4.5 | 3.94 | — | — | 3.80 | — | |
| | | | | 5.5 | — | — | — | 3.85 | — | |
| Low - Level Output Voltage | V _{OL} | V _{IN} = V _{IH} or V _{IL} | I _{OL} = 50μA | 2.0 | — | 0.0 | 0.1 | — | 0.1 | V |
| | | | | 3.0 | — | 0.0 | 0.1 | — | 0.1 | |
| | | | | 4.5 | — | 0.0 | 0.1 | — | 0.1 | |
| | | | I _{OL} = 12mA I _{OL} = 24mA I _{OL} = 75mA* | 3.0 | — | — | 0.36 | — | 0.44 | |
| | | | | 4.5 | — | — | 0.36 | — | 0.44 | |
| | | | | 5.5 | — | — | — | — | 1.65 | |
| Input Leakage Current | I _{IN} | V _{IN} = V _{CC} or GND | 5.5 | — | — | ± 0.1 | — | ± 1.0 | μA | |
| Quiescent Supply Current | I _{CC} | V _{IN} = V _{CC} or GND | 5.5 | — | — | 8.0 | — | 80.0 | | |

* : This spec indicates the capability of driving 50Ω transmission lines.
One output should be tested at a time for a 10ms maximum duration.

AC ELECTRICAL CHARACTERISTICS ($C_L = 50\text{pF}$, $R_L = 500\Omega$, Input $t_r = t_f = 3\text{ns}$)

| PARAMETER | SYMBOL | TEST CONDITION | Ta = 25°C | | | Ta = -40~85°C | | UNIT | |
|--|---------------------|----------------|---------------------|------|------|---------------|------|------|------|
| | | | V _{CC} (V) | MIN. | TYP. | MAX. | MIN. | | MAX. |
| Propagation Delay Time (A, B, C - \bar{Y}) | t_{pLH} | | 3.3 ± 0.3 | — | 8.5 | 14.2 | 1.0 | 16.3 | ns |
| | t_{pHL} | | 5.0 ± 0.5 | — | 6.4 | 9.2 | 1.0 | 10.5 | |
| Propagation Delay Time (G1 - \bar{Y}) | t_{pLH} | | 3.3 ± 0.3 | — | 7.5 | 12.8 | 1.0 | 14.7 | |
| | t_{pHL} | | 5.0 ± 0.5 | — | 6.1 | 8.9 | 1.0 | 10.2 | |
| Propagation Delay Time ($\bar{G}2$ - \bar{Y}) | t_{pLH} | | 3.3 ± 0.3 | — | 8.8 | 15.0 | 1.0 | 17.3 | |
| | t_{pHL} | | 5.0 ± 0.5 | — | 7.2 | 10.5 | 1.0 | 12.0 | |
| Input Capacitance | C _{IN} | | — | 5 | 10 | — | 10 | pF | |
| Power Dissipation Capacitance | C _{PD} (1) | | — | 143 | — | — | — | | |

Note (1) C_{PD} is defined as the value of the internal equivalent capacitance which is calculated from the operating current consumption without load.

Average operating current can be obtained by the equation :

$$I_{CC(\text{opr.})} = C_{PD} \cdot V_{CC} \cdot f_{IN} + I_{CC}$$

DIP 16PIN PACKAGE DIMENSIONS (DIP16-P-300-2.54A)

Unit in mm

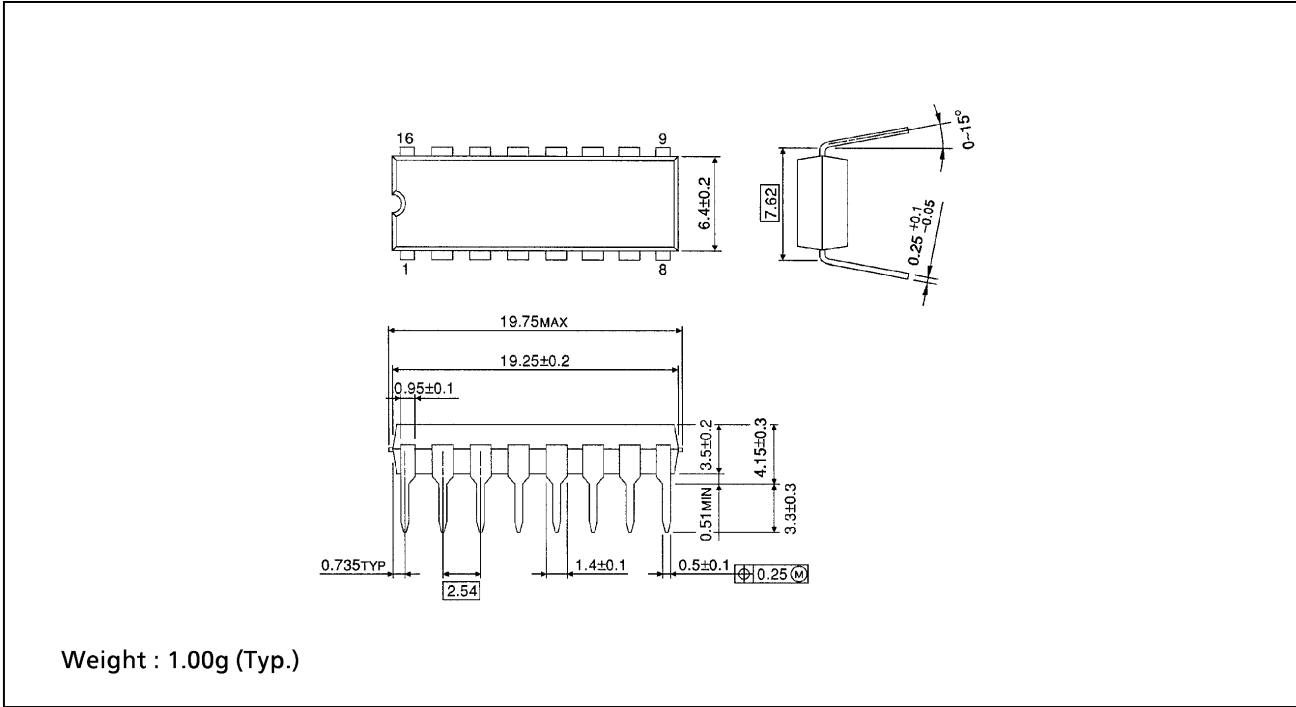

SOP 16PIN (200mil BODY) PACKAGE DIMENSIONS (SOP16-P-300-1.27)

Unit in mm

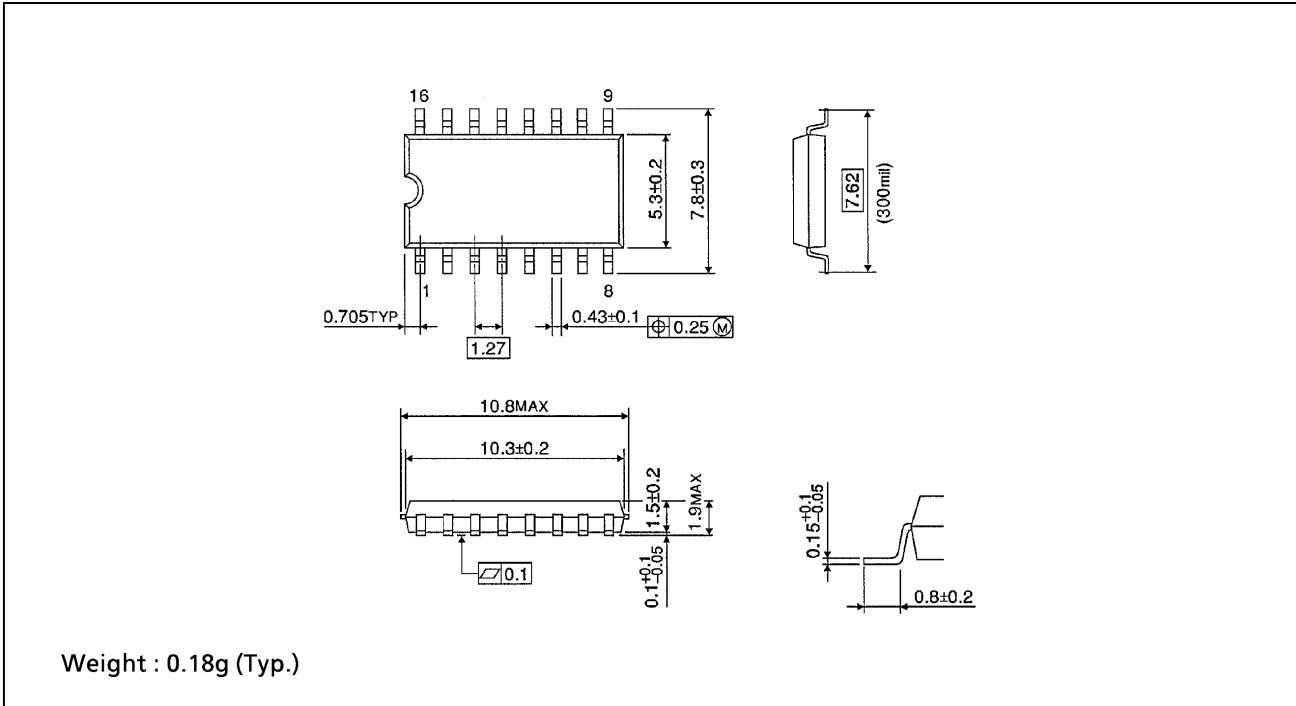

SOP 16PIN (150mil BODY) PACKAGE DIMENSIONS (SOL16-P-150-1.27)

Unit in mm

(Note) This package is not available in Japan.

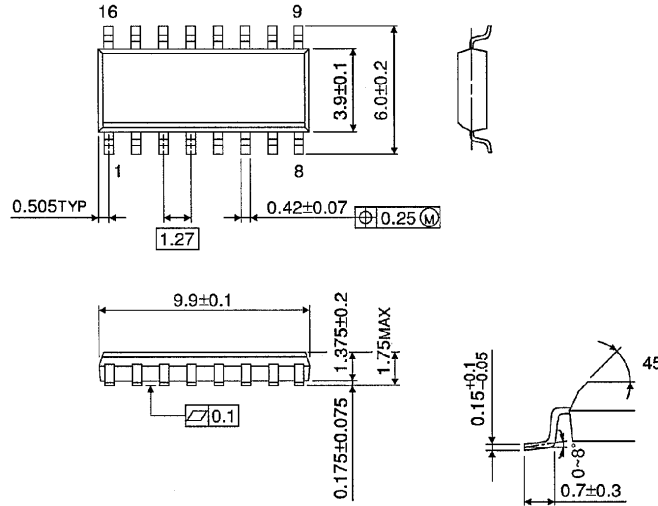

Weight : 0.13g (Typ.)

TSSOP 16PIN PACKAGE DIMENSIONS (TSSOP16-P-0044-0.65)

Unit in mm

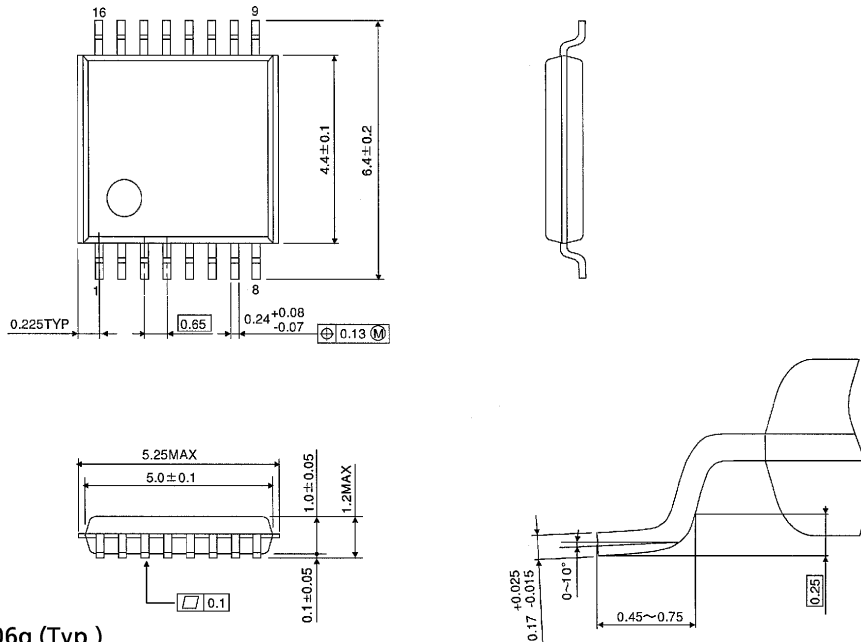

Weight : 0.06g (Typ.)

RESTRICTIONS ON PRODUCT USE

000707EBA

- TOSHIBA is continually working to improve the quality and reliability of its products. Nevertheless, semiconductor devices in general can malfunction or fail due to their inherent electrical sensitivity and vulnerability to physical stress. It is the responsibility of the buyer, when utilizing TOSHIBA products, to comply with the standards of safety in making a safe design for the entire system, and to avoid situations in which a malfunction or failure of such TOSHIBA products could cause loss of human life, bodily injury or damage to property. In developing your designs, please ensure that TOSHIBA products are used within specified operating ranges as set forth in the most recent TOSHIBA products specifications. Also, please keep in mind the precautions and conditions set forth in the "Handling Guide for Semiconductor Devices," or "TOSHIBA Semiconductor Reliability Handbook" etc..
- The TOSHIBA products listed in this document are intended for usage in general electronics applications (computer, personal equipment, office equipment, measuring equipment, industrial robotics, domestic appliances, etc.). These TOSHIBA products are neither intended nor warranted for usage in equipment that requires extraordinarily high quality and/or reliability or a malfunction or failure of which may cause loss of human life or bodily injury ("Unintended Usage"). Unintended Usage include atomic energy control instruments, airplane or spaceship instruments, transportation instruments, traffic signal instruments, combustion control instruments, medical instruments, all types of safety devices, etc.. Unintended Usage of TOSHIBA products listed in this document shall be made at the customer's own risk.
- The products described in this document are subject to the foreign exchange and foreign trade laws.
- The information contained herein is presented only as a guide for the applications of our products. No responsibility is assumed by TOSHIBA CORPORATION for any infringements of intellectual property or other rights of the third parties which may result from its use. No license is granted by implication or otherwise under any intellectual property or other rights of TOSHIBA CORPORATION or others.
- The information contained herein is subject to change without notice.