



# LM193, LM193A, LM293, LM293A, LM393, LM393A

## Low Power Dual Voltage Comparators

- Wide single-supply voltage range or dual supplies: +2V to +36V or  $\pm 1V$  to  $\pm 18V$
- Very low supply current (0.4mA) independent of supply voltage (1mW/comparator at +5V)
- Low input bias current: 25nA typ.
- Low input offset current:  $\pm 5nA$  typ.
- Low input offset voltage:  $\pm 1mV$  typ.
- Input common-mode voltage range includes ground
- Low output saturation voltage: 250mV typ. ( $I_o = 4mA$ )
- Differential input voltage range equal to the supply voltage
- TTL, DTL, ECL, MOS, CMOS compatible outputs

### Description

These devices consist of two independent low voltage comparators designed specifically to operate from a single supply over a wide range of voltages. Operation from split power supplies is also possible.

These comparators also have a unique characteristic in that the input common-mode voltage range includes ground even though operated from a single power supply voltage.

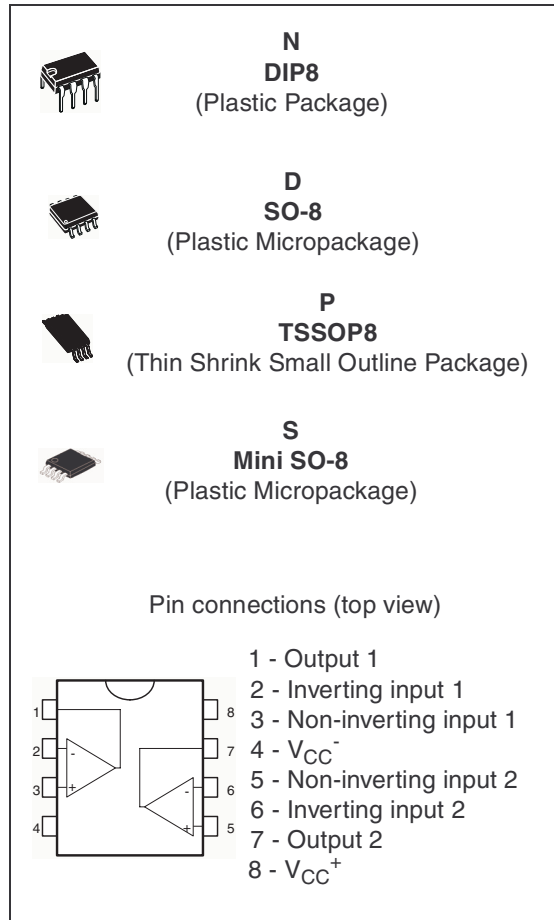

# 1 Order Codes

Part Number	Temperature Range	Package	Packing	Marking
LM193AD/LM193ADT	-55°C, +125°C	SO-8	Tube or Tape & Reel	
LM193AN		DIP8	Tube	
LM193D/LM193DT		SO-8	Tube or Tape & Reel	
LM193N		DIP8	Tube	
LM293AD/LM293ADT	-40°C, +105°C	SO-8	Tube or Tape & Reel	
LM293AN		DIP8	Tube	
LM293D/LM293DT		SO-8	Tube or Tape & Reel	
LM293N		DIP8	Tube	
LM293PT		TSSOP8 (Thin Shrink Outline Package)	Tape & Reel	
LM293ST		Mini SO-8	Tape & Reel	
LM393AD/LM393ADT	0°C, +70°C	SO-8	Tube or Tape & Reel	
LM393D/LM393DT		SO-8	Tube or Tape & Reel	
LM393N		DIP8	Tube	
LM393PT		TSSOP8 (Thin Shrink Outline Package)	Tape & Reel	
LM393ST		Mini SO-8	Tape & Reel	
LM393YDT/YD		-40°C, +125°C	SO-8 (automotive grade level)	Tube or Tape & Reel

## 2 Schematic Diagram (1/2 LM193)

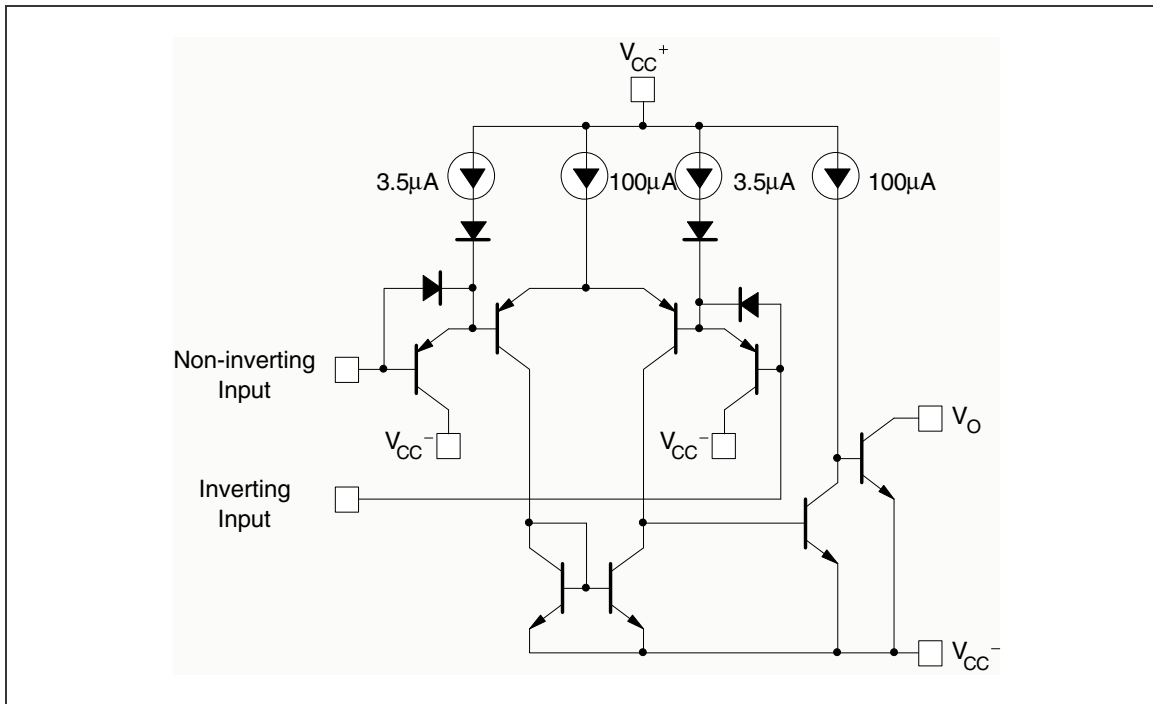

### 3 Absolute Maximum Ratings

**Table 1. Key parameters and their absolute maximum ratings**

Symbol	Parameter	Value	Unit
$V_{CC}$	Supply Voltage	$\pm 18$ or 36	V
$V_{id}$	Differential Input Voltage	$\pm 36$	V
$V_i$	Input Voltage	-0.3 to +36	V
	Output Short-circuit to Ground - note <sup>(1)</sup>	Infinite	
$P_d$	Power Dissipation <sup>(2)</sup> DIP-8 SO-8 TSSOP8 Mini SO-8	1250 710 625 580	mW
$T_{stg}$	Storage Temperature Range	-65 to +150	°C

- Short-circuits from the output to  $V_{CC}^+$  can cause excessive heating and eventual destruction. The maximum output current is approximately 20mA independent of the magnitude of  $V_{CC}^+$ .
- $P_d$  is calculated with  $T_{amb} = +25^\circ\text{C}$ ,  $T_j = +150^\circ\text{C}$  and  
 $R_{thja} = 100^\circ\text{C/W}$  for DIP8 package  
 $R_{thja} = 175^\circ\text{C/W}$  for SO-8 package  
 $R_{thja} = 200^\circ\text{C/W}$  for TSSOP8 package  
 $R_{thja} = 215^\circ\text{C/W}$  for Mini SO-8 package

**Table 2. Operating conditions**

Symbol	Parameter	Value	Unit
$V_{icm}$	Common Mode Input Voltage Range	0 to $V_{CC}^+ - 1.5$	V
$T_{oper}$	Operating Free-Air Temperature range LM193, A LM293, A LM393, A	-55 to +125 -40 to +105 0 to +70	°C

## 4 Electrical Characteristics

Table 3.  $V_{CC}^+ = +5V$ ,  $V_{CC}^- = 0V$ ,  $T_{amb} = +25^\circ C$  (unless otherwise specified)

Symbol	Parameter	LM193A - LM293A LM393A			LM193- LM293 LM393			Unit
		Min.	Typ.	Max.	Min	Typ.	Max.	
$V_{io}$	Input Offset Voltage - note <sup>(1)</sup> $T_{amb} = +25^\circ C$ $T_{min} \leq T_{amb} \leq T_{max}$		1	2 4		1	5 9	mV
$I_{io}$	Input Offset Current $T_{amb} = +25^\circ C$ $T_{min} \leq T_{amb} \leq T_{max}$		3	25 100		5	50 150	nA
$I_{ib}$	Input Bias Current ( $I^+$ or $I^-$ ) - note <sup>(2)</sup> $T_{amb} = +25^\circ C$ $T_{min} \leq T_{amb} \leq T_{max}$		25	100 300		25	250 400	nA
$A_{vd}$	Large Signal Voltage Gain $V_{CC} = 15V$ , $R_L = 15k\Omega$ , $V_o = 1V$ to $11V$	50	200		50	200		V/mV
$I_{CC}$	Supply Current (all comparators) $V_{CC} = +5V$ , no load $V_{CC} = +30V$ , no load		0.4 1	1 2.5		0.4 1	1 2.5	mA
$V_{icm}$	Input Common Mode Voltage Range - note <sup>(3)</sup> $V_{CC} = 30V$ $T_{amb} = +25^\circ C$ $T_{min} \leq T_{amb} \leq T_{max}$	0 0		$V_{CC}^+ - 1.5$ $V_{CC}^+ - 2$	0 0		$V_{CC}^+ - 1.5$ $V_{CC}^+ - 2$	V
$V_{id}$	Differential Input Voltage -note <sup>(4)</sup>			$V_{CC}^+$			$V_{CC}^+$	
$V_{OL}$	Low Level Output Voltage $V_{id} = -1V$ , $I_{sink} = 4mA$ $T_{amb} = +25^\circ C$ $T_{min} \leq T_{amb} \leq T_{max}$		250	400 700		250	400 700	mV
$I_{OH}$	High Level Output Current ( $V_{id} = 1V$ ) $V_{CC} = V_o = 30V$ $T_{amb} = +25^\circ C$ $T_{min} \leq T_{amb} \leq T_{max}$		0.1	1		0.1	1	nA $\mu A$
$I_{SINK}$	Output Sink Current $V_{id} = 1V$ , $V_o = 1.5V$	6	16		6	16		mA
tre	Response Time - note <sup>(5)</sup> $R_L = 5.1k\Omega$ connected to $V_{CC}^+$		1.3			1.3		$\mu s$
trel	Large Signal Response Time $R_L = 5.1k\Omega$ connected to $V_{CC}^+$ , $e_1 = TTL$ , $V_{(ref)} = +1.4V$		300			300		ns

- At output switch point,  $V_o \approx 1.4V$ ,  $R_s = 0$  with  $V_{CC}^+$  from 5V to 30V, and over the full common-mode range (0V to  $V_{CC}^+ - 1.5V$ ).
- The direction of the input current is out of the IC due to the PNP input stage. This current is essentially constant, independent of the state of the output, so no loading charge exists on the reference of input lines.
- The input common-mode voltage of either input signal voltage should not be allowed to go negative by more than 0.3V. The upper end of the common-mode voltage range is  $V_{CC}^+ - 1.5V$ , but either or both inputs can go to +30V without damage.
- The response time specified is for a 100mV input step with 5mV overdrive. For larger overdrive signals 300ns can be obtained.
- Positive excursions of input voltage may exceed the power supply level. As long as the other voltage remains within the common-mode range, the comparator will provide a proper output state. The low input voltage state must not be less than -0.3V (or 0.3V below the negative power supply, if used).

Figure 1. Supply current vs. supply voltage

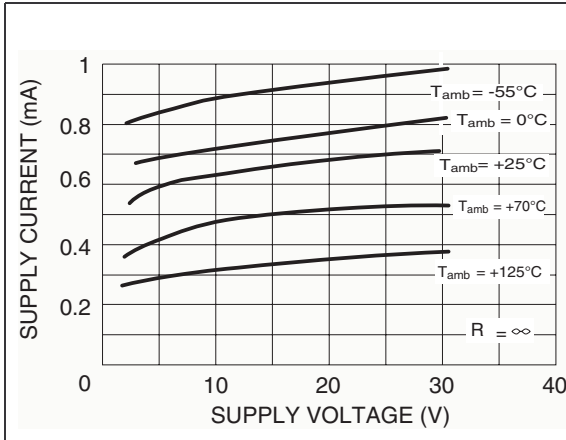

Figure 2. Input current vs. supply voltage

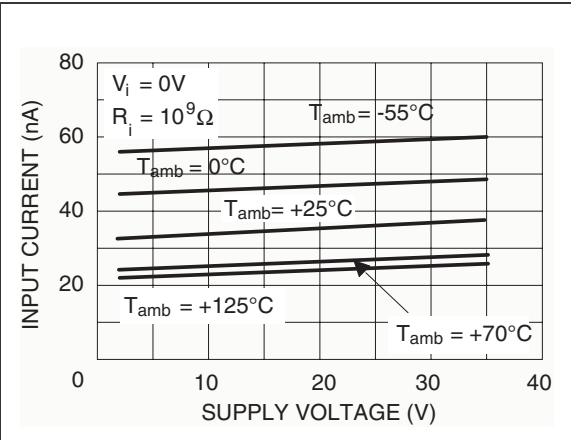

Figure 3. Output saturation voltage vs. frequency

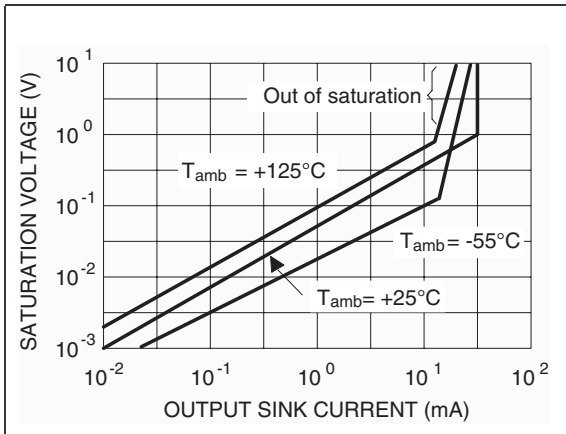

Figure 4. Response time for various input overdrives - negative transition

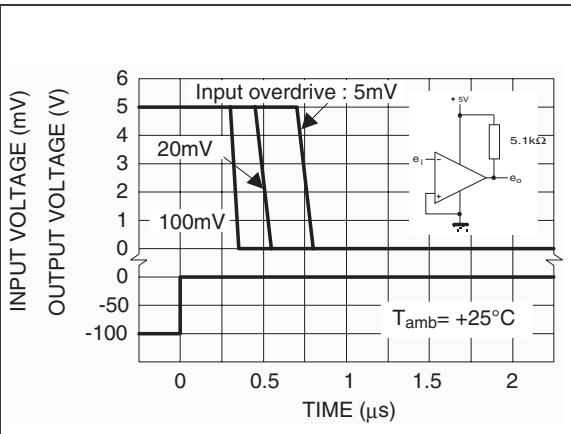
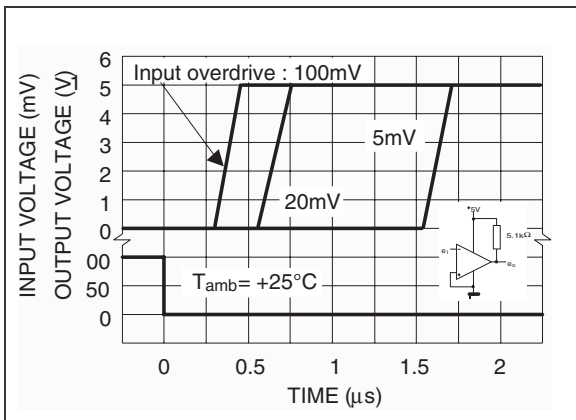

Figure 5. Response time for various input overdrives - positive transition



### 4.1 Typical applications

Figure 6. Basic comparator

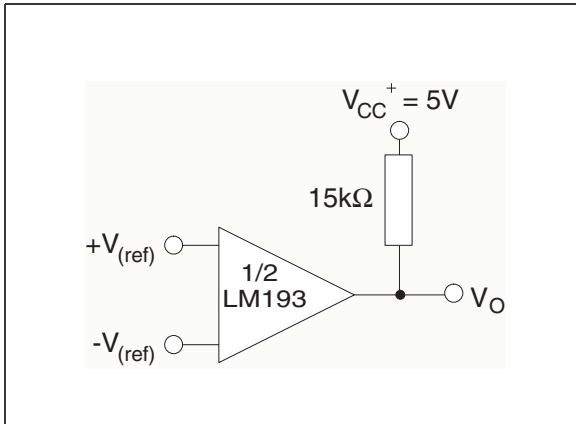

Figure 7. Driving TTL

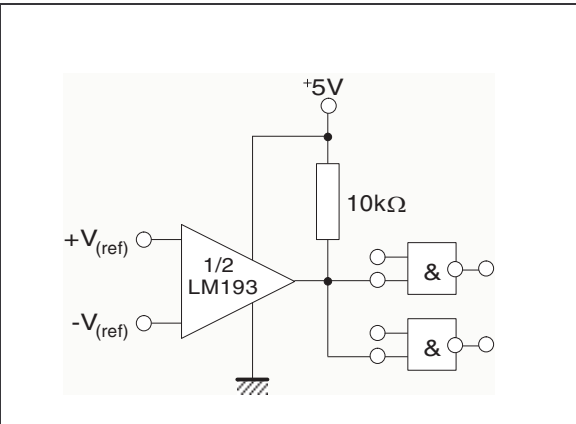

Figure 8. Low frequency op-amp

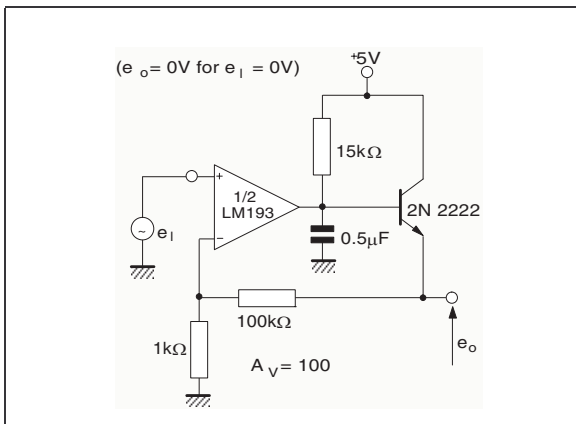

Figure 9. Driving CMOS

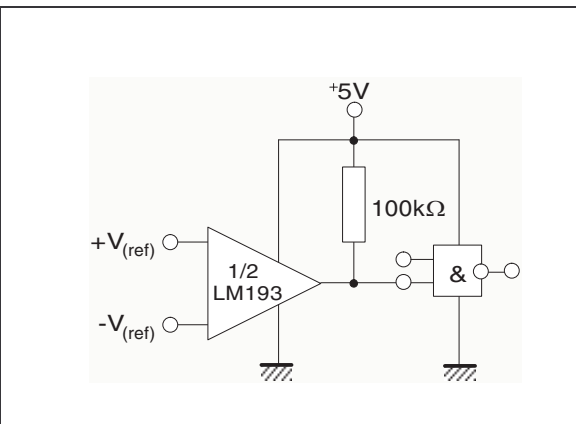

Figure 10. Low frequency op-amp

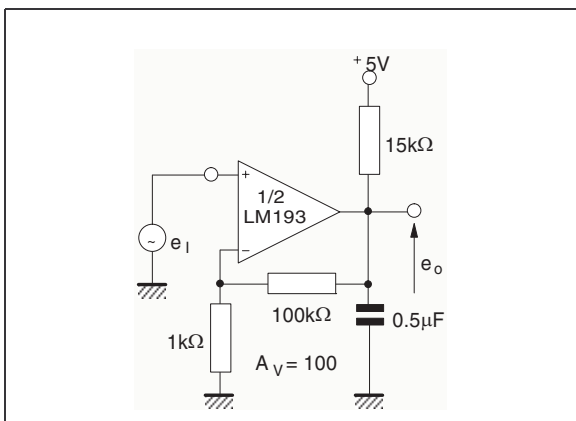

Figure 11. Transducer amplifier

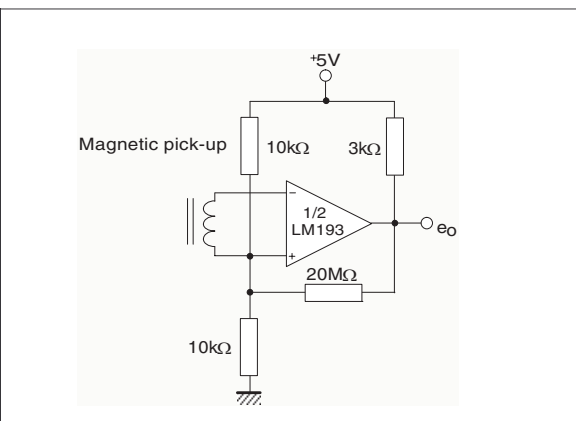

Figure 12. Low frequency op-amp with offset adjust

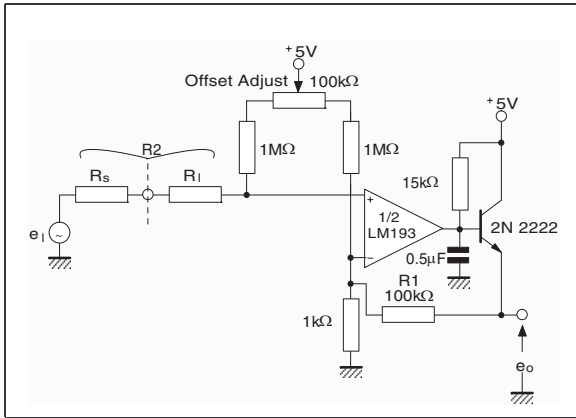

Figure 13. Zero crossing detector (single power supply)

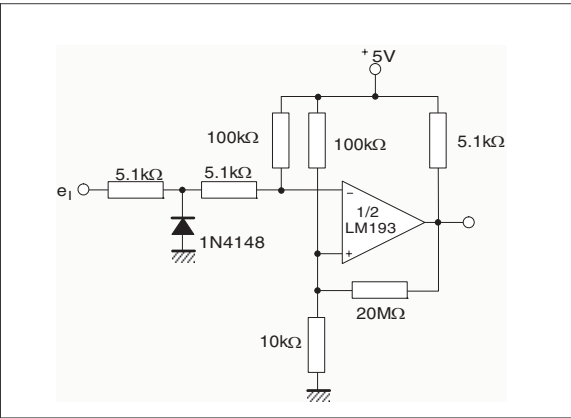

Figure 14. Limit comparator

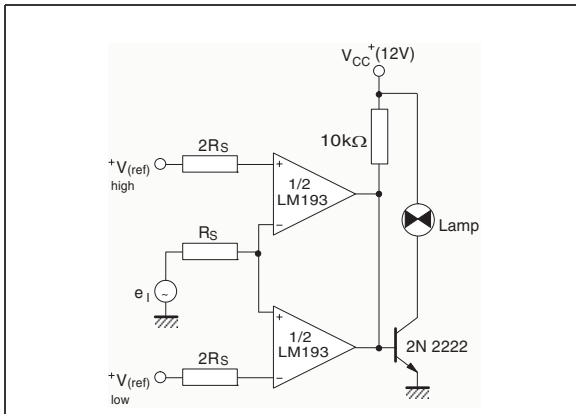

Figure 15. Crystal controlled oscillator

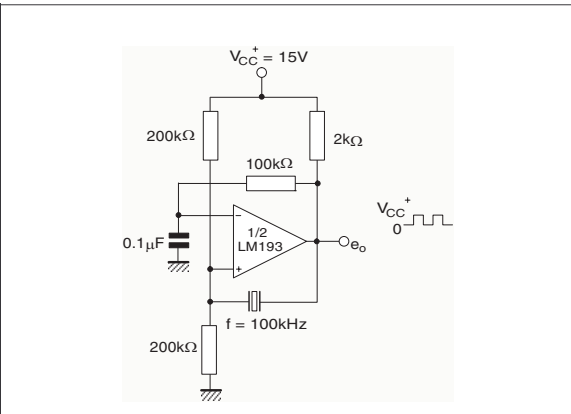

Figure 16. Split-supply applications - zero crossing detector

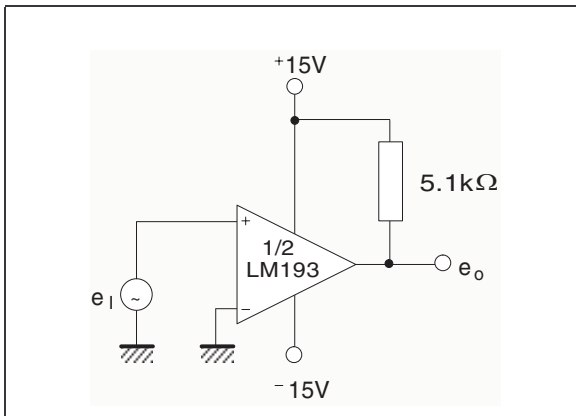

Figure 17. Comparator with a negative reference

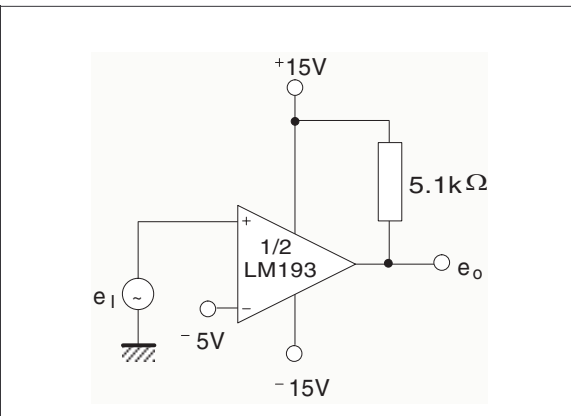
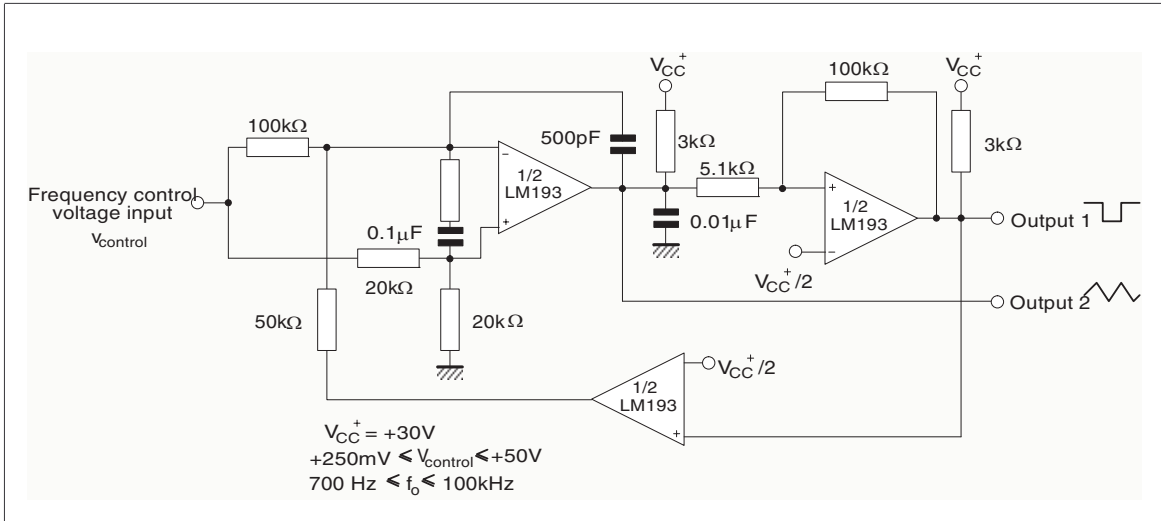



Figure 18. Two-decade high-frequency VCO



## 5 Package Mechanical Data

In order to meet environmental requirements, ST offers these devices in ECOPACK® packages. These packages have a Lead-free second level interconnect. The category of second level interconnect is marked on the package and on the inner box label, in compliance with JEDEC Standard JESD97. The maximum ratings related to soldering conditions are also marked on the inner box label. ECOPACK is an ST trademark. ECOPACK specifications are available at: [www.st.com](http://www.st.com).

### 5.1 DIP8 package

**Plastic DIP-8 MECHANICAL DATA**

DIM.	mm.			inch		
	MIN.	TYP.	MAX.	MIN.	TYP.	MAX.
A		3.3			0.130	
a1	0.7			0.028		
B	1.39		1.65	0.055		0.065
B1	0.91		1.04	0.036		0.041
b		0.5			0.020	
b1	0.38		0.5	0.015		0.020
D			9.8			0.386
E		8.8			0.346	
e		2.54			0.100	
e3		7.62			0.300	
e4		7.62			0.300	
F			7.1			0.280
I			4.8			0.189
L		3.3			0.130	
Z	0.44		1.6	0.017		0.063

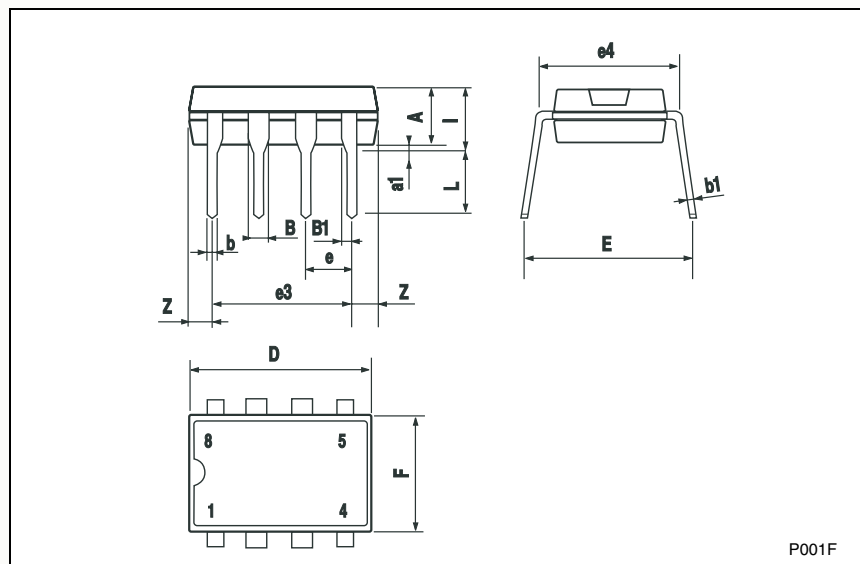

P001F

## 5.2 SO8 package

SO-8 MECHANICAL DATA						
DIM.	mm.			inch		
	MIN.	TYP.	MAX.	MIN.	TYP.	MAX.
A	1.35		1.75	0.053		0.069
A1	0.10		0.25	0.04		0.010
A2	1.10		1.65	0.043		0.065
B	0.33		0.51	0.013		0.020
C	0.19		0.25	0.007		0.010
D	4.80		5.00	0.189		0.197
E	3.80		4.00	0.150		0.157
e		1.27			0.050	
H	5.80		6.20	0.228		0.244
h	0.25		0.50	0.010		0.020
L	0.40		1.27	0.016		0.050
k	8° (max.)					
ddd			0.1			0.04

0016023/C

### 5.3 TSSOP8 package

TSSOP8 MECHANICAL DATA						
DIM.	mm.			inch		
	MIN.	TYP.	MAX.	MIN.	TYP.	MAX.
A			1.2			0.047
A1	0.05		0.15	0.002		0.006
A2	0.80	1.00	1.05	0.031	0.039	0.041
b	0.19		0.30	0.007		0.012
c	0.09		0.20	0.004		0.008
D	2.90	3.00	3.10	0.114	0.118	0.122
E	6.20	6.40	6.60	0.244	0.252	0.260
E1	4.30	4.40	4.50	0.169	0.173	0.177
e		0.65			0.0256	
K	0°		8°	0°		8°
L	0.45	0.60	0.75	0.018	0.024	0.030
L1		1			0.039	

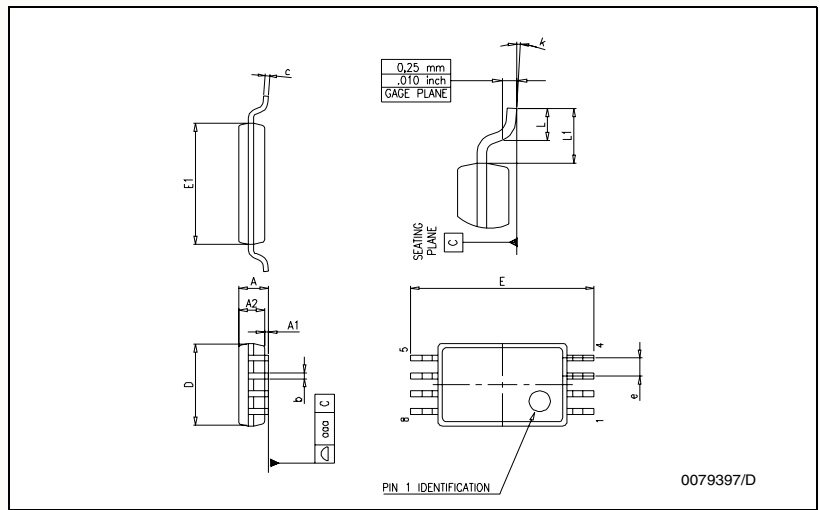

## 5.4 MiniSO8 package

miniSO-8 MECHANICAL DATA						
DIM.	mm.			inch		
	MIN.	TYP.	MAX.	MIN.	TYP.	MAX.
A			1.1			0.043
A1	0.05	0.10	0.15	0.002	0.004	0.006
A2	0.78	0.86	0.94	0.031	0.031	0.037
b	0.25	0.33	0.40	0.010	0.13	0.013
c	0.13	0.18	0.23	0.005	0.007	0.009
D	2.90	3.00	3.10	0.114	0.118	0.122
E	4.75	4.90	5.05	0.187	0.193	0.199
E1	2.90	3.00	3.10	.0114	0.118	0.122
e		0.65			0.026	
K	0°		6°	0°		6°
L	0.40	0.55	0.70	0.016	0.022	0.028
L1			0.10			0.004

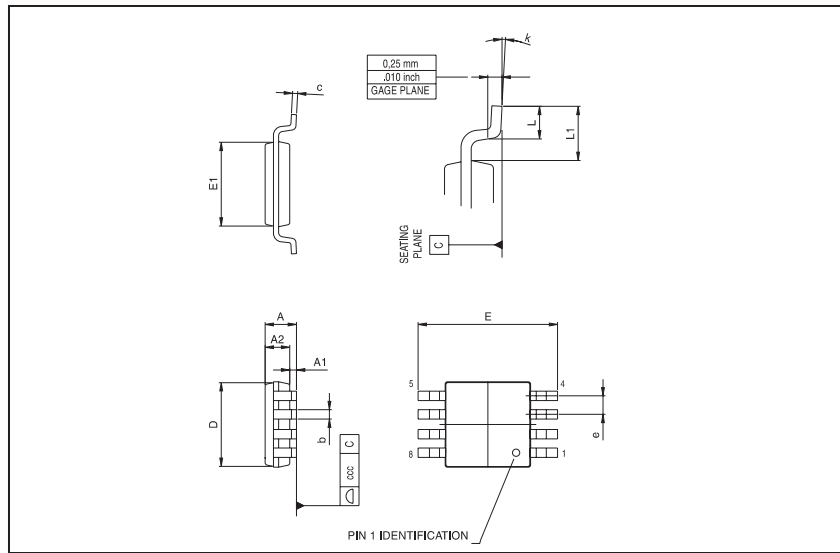

## 6 Revision History

Table 4. Document revision history

Date	Revision	Changes
July 2002	1	First Release
Jan. 2005	2	Class A of the product included in the datasheet.
May 2005	3	PPAP references inserted in the datasheet see <i>Table 1 on page 2</i> .
July 2005	4	Modification on PPAP references - Errors on part numbers see <i>Table 1 on page 2</i> .
Nov. 2005	5	Modification on <i>Table 3 on page 5</i> . LM293,A must be -40/+105°C instead of -40/+125°C.
Feb. 2006	6	Unit error for Vol parameter see <i>Table 3 on page 5</i> .

**Please Read Carefully:**

Information in this document is provided solely in connection with ST products. STMicroelectronics NV and its subsidiaries ("ST") reserve the right to make changes, corrections, modifications or improvements, to this document, and the products and services described herein at any time, without notice.

All ST products are sold pursuant to ST's terms and conditions of sale.

Purchasers are solely responsible for the choice, selection and use of the ST products and services described herein, and ST assumes no liability whatsoever relating to the choice, selection or use of the ST products and services described herein.

No license, express or implied, by estoppel or otherwise, to any intellectual property rights is granted under this document. If any part of this document refers to any third party products or services it shall not be deemed a license grant by ST for the use of such third party products or services, or any intellectual property contained therein or considered as a warranty covering the use in any manner whatsoever of such third party products or services or any intellectual property contained therein.

**UNLESS OTHERWISE SET FORTH IN ST'S TERMS AND CONDITIONS OF SALE ST DISCLAIMS ANY EXPRESS OR IMPLIED WARRANTY WITH RESPECT TO THE USE AND/OR SALE OF ST PRODUCTS INCLUDING WITHOUT LIMITATION IMPLIED WARRANTIES OF MERCHANTABILITY, FITNESS FOR A PARTICULAR PURPOSE (AND THEIR EQUIVALENTS UNDER THE LAWS OF ANY JURISDICTION), OR INFRINGEMENT OF ANY PATENT, COPYRIGHT OR OTHER INTELLECTUAL PROPERTY RIGHT.**

**UNLESS EXPRESSLY APPROVED IN WRITING BY AN AUTHORIZE REPRESENTATIVE OF ST, ST PRODUCTS ARE NOT DESIGNED, AUTHORIZED OR WARRANTED FOR USE IN MILITARY, AIR CRAFT, SPACE, LIFE SAVING, OR LIFE SUSTAINING APPLICATIONS, NOR IN PRODUCTS OR SYSTEMS, WHERE FAILURE OR MALFUNCTION MAY RESULT IN PERSONAL INJURY, DEATH, OR SEVERE PROPERTY OR ENVIRONMENTAL DAMAGE.**

Resale of ST products with provisions different from the statements and/or technical features set forth in this document shall immediately void any warranty granted by ST for the ST product or service described herein and shall not create or extend in any manner whatsoever, any liability of ST.

ST and the ST logo are trademarks or registered trademarks of ST in various countries.

Information in this document supersedes and replaces all information previously supplied.

The ST logo is a registered trademark of STMicroelectronics. All other names are the property of their respective owners.

© 2006 STMicroelectronics - All rights reserved

STMicroelectronics group of companies

Australia - Belgium - Brazil - Canada - China - Czech Republic - Finland - France - Germany - Hong Kong - India - Israel - Italy - Japan - Malaysia - Malta - Morocco - Singapore - Spain - Sweden - Switzerland - United Kingdom - United States of America

[www.st.com](http://www.st.com)

