

FEATURES

- Inherently Matched LED Current
- High Efficiency: 84% Typical
- Drives Up to Four LEDs from a 3.2V Supply
- Drives Up to Six LEDs from a 5V Supply
- 36V Rugged Bipolar Switch
- Fast 1.2MHz Switching Frequency
- Uses Tiny 1mm Tall Inductors
- Requires Only 0.22μF Output Capacitor
- Moisture Sensitivity Level 3

APPLICATIONS

- Cellular Phones
- PDAs, Handheld Computers
- Digital Cameras
- MP3 Players
- GPS Receivers

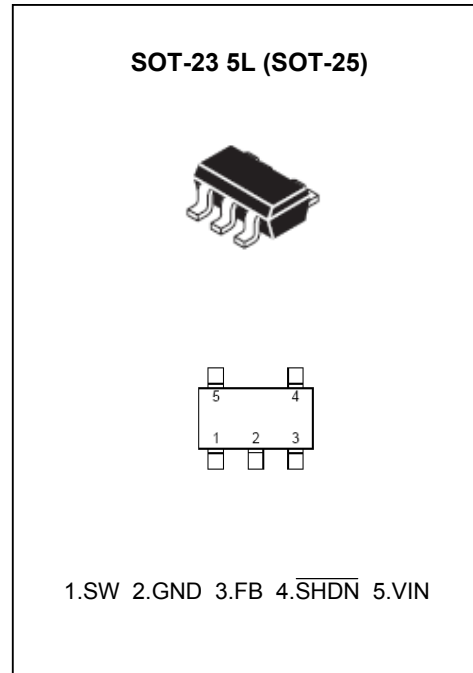

ORDERING INFORMATION

Device	Marking	Package
LM1937SF5	1937	SOT-23 5L

DESCRIPTION

The LM1937 is a step-up DC/DC converter specifically designed to drive white LEDs with a constant current. The device can drive two, three or four LEDs in series from a Li-Ion cell. Series connection of the LEDs provides identical LED currents resulting in uniform brightness and eliminating the need for ballast resistors. The output capacitor can be as small as 0.22μF, saving space versus alternative solutions. A low 95mV feedback voltage minimizes power loss for better efficiency.

TYPICAL APPLICATION CIRCUIT

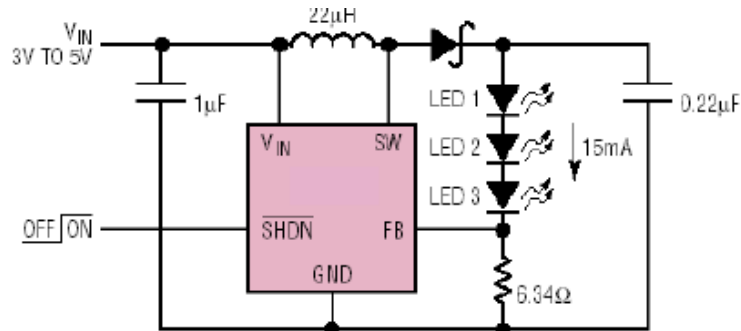
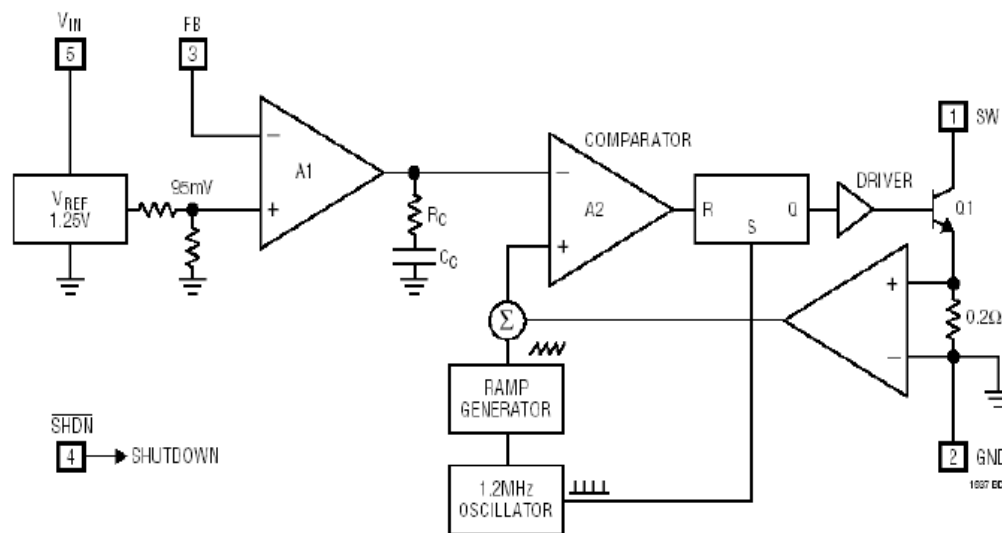

Figure 1. Li-Ion Powered Driver for Three White LEDs

PIN DESCRIPTION

PIN	PIN NAME	DESCRIPTION
1	SW	Switch Pin. Connect inductor/diode here. Minimize trace area at this pin to reduce EMI.
2	GND	Ground Pin. Connect directly to local ground plane.
3	FB	Feedback Pin. Reference voltage is 95 mV. Connect cathode of lowest LED and resistor here. Calculate resistor value according to the formula: $R_{FB} = 95 \text{ mV} / I_{LED}$.
4	SHDN	Shutdown Pin. Connect to 1.5 V or higher to enable device; 0.4 V or less to disable device.
5	VIN	Input Supply Pin. Must be locally bypassed.

BLOCK DIAGRAM



ABSOLUTE MAXIMUM RATING (Note 1)

Input Voltage (Vin)	10 V
SW Voltage	36 V
FB Voltage	10 V
SHDN Voltage	10 V
Operating Temperature (Topr)	-40 ~ +85 °C
Maximum Junction Temperature	125 °C
Storage Temperature (Tstg)	-65 ~ +125 °C
Lead Temperature (soldering, 5 sec)	260 °C

ELECTRICAL CHARACTERISTICS $T_A = 25^\circ\text{C}$, $V_{IN} = 3\text{V}$, $V_{\overline{\text{SHDN}}} = 3\text{V}$, unless otherwise noted.

PARAMETER	CONDITIONS	MIN.	TYP.	MAX.	UNIT
Minimum Operating Voltage		2.5			V
Maximum Operating Voltage				10	V
Feedback Voltage	$I_{SW} = 100\text{mA}$, Duty Cycle = 66%	86	95	104	mV
FB Pin Bias Current		10	45	100	nA
Supply Current	$\overline{\text{SHDN}} = 0\text{V}$		1.9 0.1	2.5 1.0	mA μA
Switching Frequency		0.8	1.2	1.6	MHz
Maximum Duty Cycle		85	90		%
Switch Current Limit			320		mA
Switch V_{CESAT}	$I_{SW} = 250\text{mA}$		350		mV
Switch Leakage Current	$V_{SW} = 5\text{V}$		0.01	5	μA
$\overline{\text{SHDN}}$ Voltage High		1.5			V
$\overline{\text{SHDN}}$ Voltage Low				0.4	V
$\overline{\text{SHDN}}$ Pin Bias Current			65		μA

OPERATION

The LM1937 uses a constant frequency, current mode control scheme to provide excellent line and load regulation. Operation can be best understood by referring to the block diagram in Figure 2. At the start of each oscillator cycle, the SR latch is set, which turns on the power switch Q1. A voltage proportional to the switch current is added to a stabilizing ramp and the resulting sum is fed into the positive terminal of the PWM comparator A2. When this voltage exceeds the level at the negative input of A2, the SR latch is reset turning off the power switch. The level at the negative input of A2 is set by the error amplifier A1, and is simply an amplified version of the difference between the feedback voltage and the reference voltage of 95mV. In this manner, the error amplifier sets the correct peak current level to keep the output in regulation. If the error amplifier's output increases, more current is delivered to the output; if it decreases, less current is delivered.

Minimum Output Current

The LM1937 can regulate three series LEDs connected at low output currents, down to approximately 4mA from a 4.2V supply, without pulse skipping, using the same external components as specified for 15mA operation. As current is further reduced, the device will begin skipping pulses. This will result in some low frequency ripple, although the LED current remains regulated on an average basis down to zero.

APPLICATIONS INFORMATION

Inductor Selection

A 22mH inductor is recommended for most LM1937 applications. Although small size and high efficiency are major concerns, the inductor should have low core losses at 1.2MHz and low DCR (copper wire resistance). Some inductors in this category with small size are listed in Table 1. The efficiency comparison of different inductors is shown in Figure 3.

Table 1. Recommended Inductors

PART NUMBER	DCR (Ω)	CURRENT RATING (mA)	MANUFACTURER
LQH3C220	0.71	250	Murata 814-237-1431 www.murata.com
ELJPC220KF	4.0	160	Panasonic 714-373-7334 www.panasonic.com
CDRH3D16-220	0.53	350	Sumida 847-956-0666 www.Sumida.com
LB2012B220M	1.7	75	Taiyo Yuden 408-573-4150 www.t-yuden.com
LEM2520-220	5.5	125	Taiyo Yuden 408-573-4150 www.t-yuden.com

Figure 3. Efficiency Comparison of Different Inductors

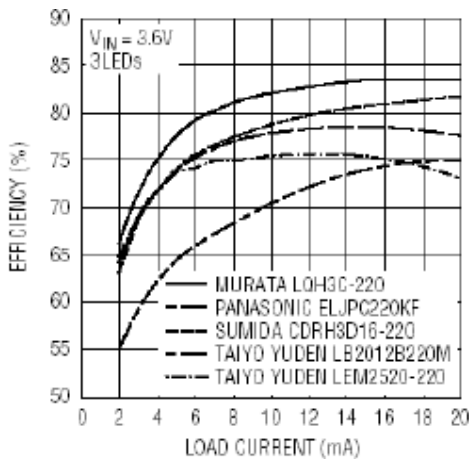

Capacitor Selection

The small size of ceramic capacitors makes them ideal for LM1937 applications. X5R and X7R types are recommended because they retain their capacitance over wider voltage and temperature ranges than other types such as Y5V or Z5U. A 1µF input capacitor and a 0.22µF output capacitor are sufficient for most LM1937 applications.

Table 2. Recommended Ceramic Capacitor Manufacturers

MANUFACTURER	PHONE	URL
Taiyo Yuden	408-573-4150	www.t-yuden.com
AVX	843-448-9411	www.avxcorp.com
Murata	814-237-1431	www.murata.com
Kemet	408-986-0424	www.kemet.com

Diode Selection

Schottky diodes, with their low forward voltage drop and fast reverse recovery, are the ideal choices for LM1937 applications. The forward voltage drop of a Schottky diode represents the conduction losses in the diode, while the diode capacitance (CT or CD) represents the switching losses. For diode selection, both forward voltage drop and diode capacitance need to be considered. Schottky diodes with higher current ratings usually have lower forward voltage drop and larger diode capacitance, which can cause significant switching losses at the 1.2MHz switching frequency of the LM1937. A Schottky diode rated at 100mA to 200mA is sufficient for most LM1937 applications. Some recommended Schottky diodes are listed in Table 3.

Table 3. Recommended Schottky Diodes

PART NUMBER	FORWARD CURRENT (mA)	VOLTAGE DROP (V)	DIODE CAPACITANCE (pF)	MANUFACTURER
CMDSH-3	100	0.58 at 100mA	7.0 at 10V	Central 831-435-1110 www.centralsemi.com
CMDSH2-3	100	0.49 at 200mA	15 at 10V	Central 831-435-1110 www.centralsemi.com
BAT54	200	0.53 at 100mA	10 at 25V	Zetex 831-543-7100 www.zetex.com

LED Current Control

The LED current is controlled by the feedback resistor (R1 in Figure 1). The feedback reference is 95mV. The LED current is $95mV/R1$. In order to have accurate LED current, precision resistors are preferred (1% is recommended). The formula and table for R1 selection are shown below. $R1 = 95mV/I_{LED}$

Table 4. R1 Resistor Value Selection

I_{LED} (mA)	R1(Ω)
5	19.1
10	9.53
12	7.87
15	6.34
20	4.75

Open-Circuit Protection

In the cases of output open circuit, when the LEDs are disconnected from the circuit or the LEDs fail, the feedback voltage will be zero. The LM1937 will then switch at a high duty cycle resulting in a high output voltage, which may cause the SW pin voltage to exceed its maximum 36V rating. A zener diode can be used at the output to limit the voltage on the SW pin (Figure 5). The zener voltage should be larger than the maximum forward voltage of the LED string. The current rating of the zener should be larger than 0.1mA.

Figure 4. LED Driver with Open-Circuit Protection

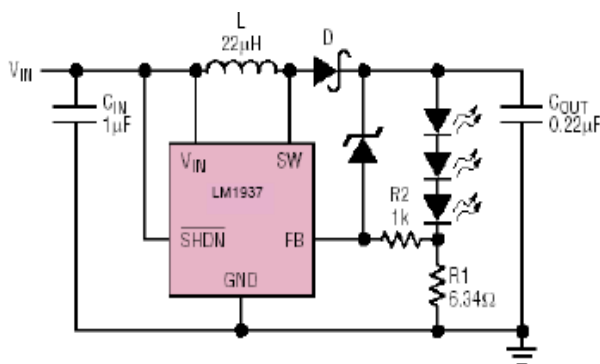

Dimming Control

There are four different types of dimming control circuits:

1. Using a PWM Signal to SHDN Pin

With the PWM signal applied to the SHDN pin, the LM1937 is turned on or off by the PWM signal. The LEDs operate at either zero or full current. The average LED current increases proportionally with the duty cycle of the PWM signal. A 0% duty cycle will turn off the LM1937 and corresponds to zero LED current. A 100% duty cycle corresponds to full current. The typical frequency range of the PWM signal is 1kHz to 10kHz. The magnitude of the PWM signal should be higher than the minimum SHDN voltage high.

2. Using a DC Voltage

For some applications, the preferred method of brightness control is a variable DC voltage to adjust the LED current. The dimming control using a DC voltage is shown in Figure 5. As the DC voltage increases, the voltage drop on R2 increases and the voltage drop on R1 decreases. Thus, the LED current decreases. The selection of R2 and R3 will make the current from the variable DC source much smaller than the LED current and much larger than the FB pin bias current. For VDC range from 0V to 2V, the selection of resistors in Figure 7 gives dimming control of LED current from 0mA to 15mA.

3. Using a Filtered PWM Signal

The filtered PWM signal can be considered as an adjustable DC voltage. It can be used to replace the variable DC voltage source in dimming control. The circuit is shown in Figure 6.

Figure 5. Dimming Control Using a DC Voltage

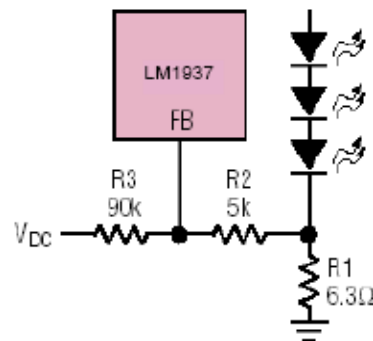

Figure 6. Dimming Control Using a Filtered PWM Signal

