

Features

- Supply Voltage up to 40V
- R_{DSon} Typically 0.8Ω at 25°C , Maximum 1.8Ω at 200°C
- Up to 1.0A Output Current
- Three Half-bridge Outputs Formed by Three High-side and Three Low-side Drivers
- Capable to Switch all Kinds of Loads Such as DC Motors, Bulbs, Resistors, Capacitors and Inductors
- No Shoot-through Current
- Outputs Short-circuit Protected
- Overtemperature Protection for Each Switch and Overtemperature Prewarning
- Undervoltage Protection
- Various Diagnostic Functions Such as Shorted Output, Open-load, Overtemperature and Power-supply Fail Detection
- Serial Data Interface, Daisy Chain Capable, up to 2 MHz Clock Frequency
- QFN18 Package

1. Description

The ATA6827 is a fully protected driver IC specially designed for high temperature applications. In mechatronic solutions, for example turbo charger or exhaust gas recirculation systems, many flaps have to be controlled by DC motor driver ICs which are located very close to the hot engine or actuator where ambient temperatures up to 150°C are usual. Due to the advantages of SOI technology junction temperatures up to 200°C are allowed. This enables new cost effective board design possibilities to achieve complex mechatronic solutions.

The ATA6827 is a fully protected Triple Half-Bridge to control up to 3 different loads by a microcontroller in automotive and industrial applications. Each of the 3 high-side and 3 low-side drivers is capable to drive currents up to 1.0A. The drivers are internally connected to form 3 half-bridges and can be controlled separately from a standard serial data interface. Therefore, all kinds of loads such as bulbs, resistors, capacitors and inductors can be combined. The IC design especially supports the application of H-bridges to drive DC motors.

Protection is guaranteed regarding short-circuit conditions, overtemperature and undervoltage. Various diagnostic functions and a very low quiescent current in standby mode opens a wide range of applications. Automotive qualification gives added value and enhanced quality for exacting requirements of automotive applications.



High Temperature Triple Half-bridge Driver with Serial Input Control

ATA6827

Preliminary

4912D-AUTO-06/07



Figure 1-1. Block Diagram

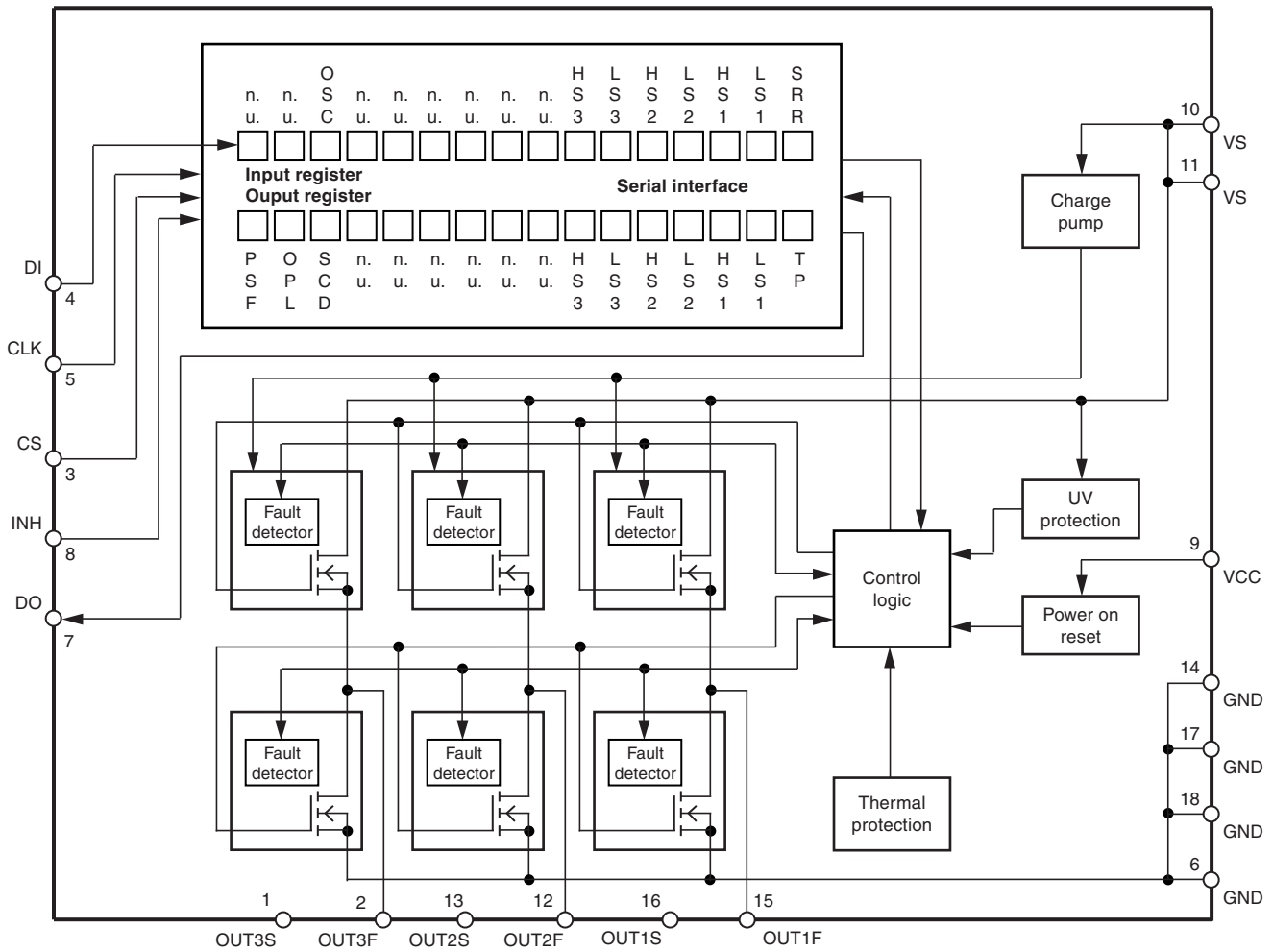

2. Pin Configuration

Figure 2-1. Pinning QFN18

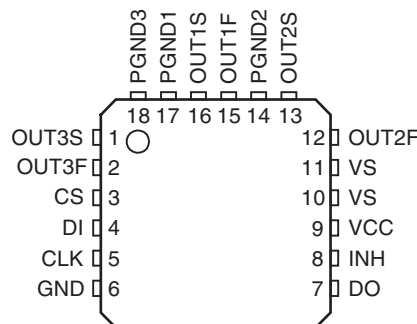

Table 2-1. Pin Description

Pin	Symbol	Function
1	OUT3S	Used only for final testing, to be connected to OUT3F
2	OUT3F	Half-bridge output 3
3	CS	Chip select input; 5-V CMOS logic level input with internal pull up; low = serial communication is enabled, high = disabled
4	DI	Serial data input; 5-V CMOS logic level input with internal pull down; receives serial data from the control device; DI expects a 16-bit control word with LSB being transferred first
5	CLK	Serial clock input; 5-V CMOS logic level input with internal pull down; controls serial data input interface and internal shift register ($f_{max} = 2$ MHz)
6	GND	Ground; reference potential
7	DO	Serial data output; 5-V CMOS logic level tri-state output for output (status) register data; sends 16-bit status information to the microcontroller (LSB is transferred first); output will remain tri-stated unless device is selected by CS = low, therefore, several ICs can operate on one data output line only.
8	INH	Inhibit input; 5-V logic input with internal pull down; low = standby, high = normal operation
9	VCC	Logic supply voltage (5 V)
10	VS	Power supply for output stages OUT1, OUT2 and OUT3, internal supply
11	VS	Power supply for output stages OUT1, OUT2 and OUT3, internal supply
12	OUT2F	Half-bridge output 2
13	OUT2S	Used only for final testing, to be connected to OUT2F
14	PGND2	Power Ground OUT2
15	OUT1F	Half-bridge output 1
16	OUT1S	Used only for final testing, to be connected to OUT13F
17	PGND1 PGND3	Power Ground OUT1 and OUT3
18	PGND1 PGND3	Power Ground OUT1 and OUT3

3. Functional Description

3.1 Serial Interface

Data transfer starts with the falling edge of the CS signal. Data must appear at DI synchronized to CLK and are accepted on the falling edge of the CLK signal. LSB (bit 0, SRR) has to be transferred first. Execution of new input data is enabled on the rising edge of the CS signal. When CS is high, pin DO is in tri-state condition. This output is enabled on the falling edge of CS. Output data will change their state with the rising edge of CLK and stay stable until the next rising edge of CLK appears. LSB (bit 0, TP) is transferred first.

Figure 3-1. Data Transfer

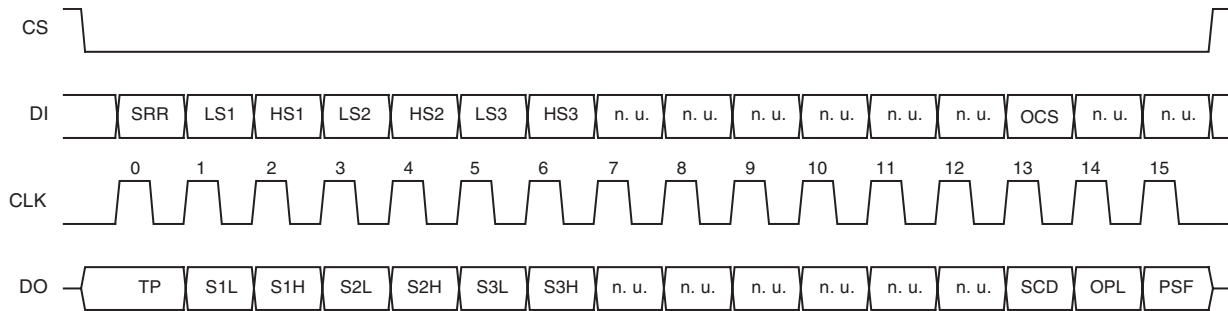

Table 3-1. Input Data Protocol

Bit	Input Register	Function
0	SRR	Status register reset (high = reset; the bits PSF, OPL and SCD in the output data register are set to low)
1	LS1	Controls output LS1 (high = switch output LS1 on)
2	HS1	Controls output HS1 (high = switch output HS1 on)
3	LS2	See LS1
4	HS2	See HS1
5	LS3	See LS1
6	HS3	See HS1
7	n. u.	Not used
8	n. u.	Not used
9	n. u.	Not used
10	n. u.	Not used
11	n. u.	Not used
12	n. u.	Not used
13	OCS	Overcurrent shutdown (high = overcurrent shutdown is active)
14	n. u.	Not used
15	n. u.	Not used

Table 3-2. Output Data Protocol

Bit	Output (Status) Register	Function
0	TP	Temperature prewarning: high = warning
1	Status LS1	High = output is on, low = output is off; not affected by SRR
2	Status HS1	High = output is on, low = output is off; not affected by SRR
3	Status LS2	Description see LS1
4	Status HS2	Description see HS1
5	Status LS3	Description see LS1
6	Status HS3	Description see HS1
7	n. u.	Not used
8	n. u.	Not used
9	n. u.	Not used
10	n. u.	Not used
11	n. u.	Not used
12	n. u.	Not used
13	SCD	Short circuit detected: set high when at least one high-side or low-side switch is switched off by a short-circuit condition. Bits 1 to 6 can be used to detect the shorted switch.
14	OPL	Open load detected: set high, when at least one active high-side or low-side switch sinks/sources a current below the open load threshold current.
15	PSF	Power-supply fail: undervoltage at pin VS detected

After power-on reset, the input register has the following status:

Bit 15	Bit 14	Bit 13 (OCS)	Bit 12	Bit 11	Bit 10	Bit 9	Bit 8	Bit 7	Bit 6 (HS3)	Bit 5 (LS3)	Bit 4 (HS2)	Bit 3 (LS2)	Bit 2 (HS1)	Bit 1 (LS1)	Bit 0 (SRR)
x	x	H	x	x	x	x	x	x	L	L	L	L	L	L	L

The following patterns are used to enable internal test modes of the IC. It is not recommended to use these patterns during normal operation.

Bit 15	Bit 14	Bit 13 (OCS)	Bit 12	Bit 11	Bit 10	Bit 9	Bit 8	Bit 7	Bit 6 (HS3)	Bit 5 (LS3)	Bit 4 (HS2)	Bit 3 (LS2)	Bit 2 (HS1)	Bit 1 (LS1)	Bit 0 (SRR)
H	H	H	H	H	L	L	L	L	L	L	L	L	L	L	L
H	H	H	L	L	H	H	L	L	L	L	L	L	L	L	L
H	H	H	L	L	L	L	H	H	L	L	L	L	L	L	L

3.2 Power-supply Fail

In case of undervoltage at pin VS, the Power-Supply Fail bit (PSF) in the output register is set and all outputs are disabled. To detect an undervoltage, its duration has to be longer than the undervoltage detection delay time t_{dUV} . The outputs are enabled immediately when supply voltage recovers to a normal operating value. The PSF bit stays high until it is reset by the SRR (Status Register Reset) bit in the input register.

3.3 Open-load Detection

If the current through a high-side or low-side switch in the ON-state stays below the open-load detection threshold, the open-load detection bit (OPL) in the output register is set.

The OPL bit stays high until it is reset by the SRR bit in the input register. To detect an open load, its duration has to be longer than the open-load detection delay time t_{dSd} .

3.4 Overtemperature Protection

If the junction temperature of one or more output stages exceeds the thermal prewarning threshold, $T_{jPW\ set}$, the temperature prewarning bit (TP) in the output register is set. When the temperature falls below the thermal prewarning threshold, $T_{jPW\ reset}$, the bit TP is reset. The TP bit can be read without transferring a complete 16-bit data word. The status of TP is available at pin DO with the falling edge of CS. After the microcontroller has read this information, CS is set high and the data transfer is interrupted without affecting the status of input and output registers.

If the junction temperature of one or more output stages exceeds the thermal shutdown threshold, $T_{j\ switch\ off}$, all outputs are disabled and the corresponding bits in the output register are set to low. The outputs can be enabled again when the temperature falls below the thermal shutdown threshold, $T_{j\ switch\ on}$ and the SRR bit in the input register is set to high. Hysteresis of thermal prewarning and shutdown threshold avoids oscillations.

3.5 Short-circuit Protection

The output currents are limited by a current regulator. Overcurrent detection is activated by writing a high to the OCS (Overcurrent Shutdown) bit in the input register. When the current in an output stage exceeds the overcurrent limitation and shutdown threshold, it is switched off after a delay time (t_{dSd}). The short-circuit detection bit (SCD) is set and the corresponding status bit in the output register is set to low. For OCS = low the overcurrent shutdown is inactive. The SCD bit is also set if the current exceeds the overcurrent limitation and shutdown threshold, but the outputs are not affected. By writing a high to the SRR bit in the input register the SCD bit is reset and the disabled outputs are enabled.

3.6 Inhibit

Applying 0V to pin 8 (INH) inhibits the ATA6827.

All output switches are then turned off and switched to tri-state. The data in the output register is deleted. The output switches can be activated again by switching pin 8 (INH) to 5V which initiates an internal power-on reset.

4. Absolute Maximum Ratings

Stresses beyond those listed under “Absolute Maximum Ratings” may cause permanent damage to the device. This is a stress rating only and functional operation of the device at these or any other conditions beyond those indicated in the operational sections of this specification is not implied. Exposure to absolute maximum rating conditions for extended periods may affect device reliability.

All values refer to GND pins.

Parameters	Pin	Symbol	Value	Unit
Supply voltage	10, 11	V_{VS}	-0.3 to +40	V
Supply voltage $t < 0.5s; I_S > -2A$	10, 11	V_{VS}	-1	V
Logic supply voltage	9	V_{VCC}	-0.3 to +7	V
Logic input voltage	3, 4, 5, 8	$V_{CS}, V_{DI}, V_{CLK}, V_{INH}$	-0.3 to $V_{VCC} + 0.3$	V
Logic output voltage	7	V_{DO}	-0.3 to $V_{VCC} + 0.3$	V
Input current	3, 4, 5, 8	$I_{CS}, I_{DI}, I_{CLK}, I_{INH}$	-10 to +10	mA
Output current	7	I_{DO}	-10 to +10	mA
Output current	2, 12, 15	$I_{Out3}, I_{Out2}, I_{Out1}$	Internally limited, see output specification	
Output voltage	2, 12, 15	$I_{Out3}, I_{Out2}, I_{Out1}$	-0.3 to +40	V
Reverse conducting current ($t_{pulse} = 150 \mu s$)	2, 12, 15	$I_{Out3}, I_{Out2}, I_{Out1}$	17	A
Junction temperature range		T_j	-40 to +200	°C
Storage temperature range		T_{STG}	-55 to +200	°C
Ambient temperature range		T_a	-40 to +150	°C

5. Thermal Resistance

Parameters	Test Conditions	Symbol	Value	Unit
Junction case		R_{thjc}	maximum 15	K/W
Junction ambient	(1)	R_{thJA}	40	K/W

Notes: 1. Depends on PCB board design

6. Operating Range

Parameters	Symbol	Value	Unit
Supply voltage	V_{VS}	$V_{UV}^{(2)}$ to 40	V
Logic supply voltage	V_{VCC}	4.75 to 5.25	V
Logic input voltage	$V_{CS}, V_{DI}, V_{CLK}, V_{INH}$	-0.3 to V_{VCC}	V
Serial interface clock frequency	f_{CLK}	2	MHz
Junction temperature range	T_j	-40 to +200	°C

Note: Threshold for undervoltage detection

7. Noise and Surge Immunity

Parameters	Test Conditions	Value
Conducted interferences	ISO 7637-1	Level 4 ⁽¹⁾
Interference suppression	VDE 0879 Part 2	Level 5
ESD (Human Body Model)	ESD S 5.1	2 kV
CDM (Charged Device Model)	ESD STM 5.3.1-1999 all pins	500V

Note: Test pulse 5: $V_{smax} = 40V$

8. Electrical Characteristics

$7.5V < V_{VS} < 40V$; $4.75V < V_{VCC} < 5.25V$; INH = High; $-40^{\circ}C \leq T_j \leq 200^{\circ}C$; $T_a \leq 150^{\circ}C$; unless otherwise specified, all values refer to GND pins.

No.	Parameters	Test Conditions	Pin	Symbol	Min.	Typ.	Max.	Unit	Type*
1	Current Consumption								
1.1	Quiescent current VS	$V_{VS} < 20V$, INH = low	10, 11	I_{VS}		1	60	μA	A
1.2	Quiescent current VCC	$4.75V < V_{VCC} < 5.25V$, INH = low	9	I_{VCC}		15	40	μA	A
1.3	Supply current VS	$V_{VS} < 20V$ normal operating, all outputs off	10, 11	I_{VS}		4	6	mA	A
1.4	Supply current VCC	$4.75V < V_{VCC} < 5.25V$, normal operating	9	I_{VCC}		350	500	μA	A
1.5	Discharge current VS	$V_{VS} = 32.5V$, INH = low	10, 11	I_{VS}	0.5		5.5	mA	A
1.6	Discharge current VS	$V_{VS} = 40V$, INH = low	10, 11	I_{VS}	2.0		10	mA	A
2	Undervoltage Detection, Power-on Reset								
2.1	Power-on reset threshold		9	V_{VCC}	3.1	3.9	4.5	V	A
2.2	Power-on reset delay time	After switching on V_{CC}		t_{dPor}	30	95	190	μs	A
2.3	Undervoltage-detection threshold	$V_{CC} = 5V$	10, 11	V_{UV}	5.5		7.1	V	A
2.4	Undervoltage-detection hysteresis	$V_{CC} = 5V$	10, 11	ΔV_{UV}		0.6		V	A
2.5	Undervoltage-detection delay time			t_{dUV}	10		40	μs	A
3	Thermal Prewarning and Shutdown								
3.1	Thermal prewarning set			$T_{jPW\ set}$	170	195	220	$^{\circ}C$	B
3.2	Thermal prewarning reset			$T_{jPW\ reset}$	155	180	205	$^{\circ}C$	B
3.3	Thermal prewarning hysteresis			ΔT_{jPW}		15		$^{\circ}C$	B
3.4	Thermal shutdown off			$T_{j\ switch\ off}$	200	225	250	$^{\circ}C$	B
3.5	Thermal shutdown on			$T_{j\ switch\ on}$	185	210	235	$^{\circ}C$	B

*) Type means: A = 100% tested, B = 100% correlation tested, C = Characterized on samples, D = Design parameter

Note: 1. Delay time between rising edge of the input signal at pin CS after data transmission and switch on output stages to 90% of final level. Device not in standby for $t > 1\ ms$

8. Electrical Characteristics (Continued)

7.5V < V_{VS} < 40V; 4.75V < V_{VCC} < 5.25 V; INH = High; -40°C ≤ T_j ≤ 200°C; T_a ≤ 150°C; unless otherwise specified, all values refer to GND pins.

No.	Parameters	Test Conditions	Pin	Symbol	Min.	Typ.	Max.	Unit	Type*
3.6	Thermal shutdown hysteresis			$\Delta T_{j \text{ switch off}}$		15		°C	B
3.7	Ratio thermal shutdown off/thermal prewarning set			$\frac{T_{j \text{ switch off}}}{T_{jPW \text{ set}}}$	1.05	1.15			B
3.8	Ratio thermal shutdown on/thermal prewarning reset			$\frac{T_{j \text{ switch on}}}{T_{jPW \text{ reset}}}$	1.05	1.15			B
4	Output Specification (OUT1-OUT3)								
4.1	On resistance	I _{Out 1-3} = -0.9A	2, 12, 15	R _{DSON1-3}			1.8	Ω	A
4.2		I _{Out 1-3} = +0.9A	2, 12, 15	R _{DSON1-3}			1.8	Ω	A
4.3	High-side output leakage current	V _{Out 1-3} = 0V, output stages off	2, 12, 15	I _{Out1-3}	-60			μA	A
4.4	Low-side output leakage current	V _{Out 1-3} = V _{VS} , output stages off	2, 12, 15	I _{Out1-3}			300	μA	A
4.5	High-side switch reverse diode forward voltage	I _{Out 1-3} = 1.5A	2, 12, 15	V _{Out1-3} - V _{VS}			2	V	A
4.6	Low-side switch reverse diode forward voltage	I _{Out 1-3} = -1.5A	2, 12, 15	V _{Out 1-3}	-2			V	A
4.7	High-side overcurrent limitation and shutdown threshold	7.5V < V _S < 20V	2, 12, 15	I _{Out1-3}	1.0	1.3	1.7	AA	A
4.8	Low-side overcurrent limitation and shutdown threshold	7.5V < V _S < 20V	2, 12, 15	I _{Out1-3}	-1.7	-1.3	-1.0	A	A
4.18	High-side overcurrent limitation and shutdown threshold	20V < V _S < 40V	2, 12, 15	I _{Out1-3}	1.0	1.3	2.0	AA	A
4.19	Low-side overcurrent limitation and shutdown threshold	20V < V _S < 40V	2, 12, 15	I _{Out1-3}	-2.0	-1.3	-1.0	A	A
4.9	Overcurrent shutdown delay time		2, 12, 15	t _{dSd}	10		40	μs	A
4.10	High-side open-load detection threshold		2, 12, 15	I _{Out1-3}	-55	-30	-5	mA	A
4.11	Low-side open-load detection threshold		2, 12, 15	I _{Out1-3}	5	30	55	mA	A
4.12	Open-load detection delay time			t _{dSd}	200		600	μs	A

*) Type means: A = 100% tested, B = 100% correlation tested, C = Characterized on samples, D = Design parameter

Note: 1. Delay time between rising edge of the input signal at pin CS after data transmission and switch on output stages to 90% of final level. Device not in standby for t > 1 ms

8. Electrical Characteristics (Continued)

7.5V < V_{VS} < 40V; 4.75V < V_{VCC} < 5.25 V; INH = High; -40°C ≤ T_j ≤ 200°C; T_a ≤ 150°C; unless otherwise specified, all values refer to GND pins.

No.	Parameters	Test Conditions	Pin	Symbol	Min.	Typ.	Max.	Unit	Type*
4.13	High-side output switch on delay ⁽¹⁾	V _{VS} = 13V R _{Load} = 30Ω		t _{don}			20	μs	A
4.14	Low-side output switch on delay ⁽¹⁾	V _{VS} = 13V R _{Load} = 30Ω		t _{don}			20	μs	A
4.15	High-side output switch off delay ⁽¹⁾	V _{VS} = 13V R _{Load} = 30Ω		t _{doff}			20	μs	A
4.16	Low-side output switch off delay ⁽¹⁾	V _{VS} = 13V R _{Load} = 30Ω		t _{doff}			3	μs	A
4.17	Dead time between corresponding high- and low-side switches	V _{VS} = 13V R _{Load} = 30Ω		t _{don} - t _{doff}	1			μs	A
5	Logic Inputs DI, CLK, CS, INH								
5.1	Input voltage low-level threshold		3, 4, 5, 8	V _{IL}	0.3 × V _{VCC}			V	A
5.2	Input voltage high-level threshold		3, 4, 5, 8	V _{IH}			0.7 × V _{VCC}	V	A
5.3	Hysteresis of input voltage		3, 4, 5, 8	ΔV _I	50		700	mV	B
5.4	Pull-down current pin DI, CLK, INH	V _{DI} , V _{CLK} , V _{INH} = V _{CC}	4, 5, 8	I _{PD}	5		70	μA	A
5.5	Pull-up current Pin CS	V _{CS} = 0V	3	I _{PU}	-70		-5	μA	A
6	Serial Interface – Logic Output DO								
6.1	Output-voltage low level	I _{DOL} = 2 mA	7	V _{DOL}			0.4	V	A
6.2	Output-voltage high level	I _{DOL} = -2 mA	7	V _{DOH}	V _{VCC} -0.7V			V	A
6.3	Leakage current (tri-state)	V _{CS} = V _{CC} 0V < V _{DO} < V _{VCC}	7	I _{DO}	-15		+15	μA	A
7	Inhibit Input - Timing								
7.1	Delay time from standby to normal operation			t _{dINH}			100	μs	A

*) Type means: A =100% tested, B = 100% correlation tested, C = Characterized on samples, D = Design parameter

Note: 1. Delay time between rising edge of the input signal at pin CS after data transmission and switch on output stages to 90% of final level. Device not in standby for t > 1 ms

9. Serial Interface – Timing

No.	Parameters	Test Conditions	Pin	Timing Chart No. ⁽¹⁾	Symbol	Min.	Typ.	Max.	Unit	Type*
8.1	DO enable after CS falling edge	$C_{DO} = 100 \text{ pF}$	7	1	t_{ENDO}			200	ns	D
8.2	DO disable after CS rising edge	$C_{DO} = 100 \text{ pF}$	7	2	t_{DISDO}			200	ns	D
8.3	DO fall time	$C_{DO} = 100 \text{ pF}$	7	-	t_{DOF}			100	ns	D
8.4	DO rise time	$C_{DO} = 100 \text{ pF}$	7	-	t_{DOR}			100	ns	D
8.5	DO valid time	$C_{DO} = 100 \text{ pF}$	7	10	t_{DOVal}			200	ns	D
8.6	CS setup time		3	4	$t_{CSSethl}$	225			ns	D
8.7	CS setup time		3	8	$t_{CSSethh}$	225			ns	D
8.8	CS high time		3	9	t_{CSh}	500			ns	D
8.9	CLK high time		5	5	t_{CLKh}	225			ns	D
8.10	CLK low time		5	6	t_{CLKl}	225			ns	D
8.11	CLK period time		5	-	t_{CLKp}	500			ns	D
8.12	CLK setup time		5	7	$t_{CLKsethl}$	225			ns	D
8.13	CLK setup time		5	3	$t_{CLKsethh}$	225			ns	D
8.14	DI setup time		4	11	t_{DIset}	40			ns	D
8.15	DI hold time		4	12	t_{DIHold}	40			ns	D

*) Type means: A =100% tested, B = 100% correlation tested, C = Characterized on samples, D = Design parameter

Note: 1. Serial Interface Timing with Chart Numbers

Figure 9-1. Serial Interface Timing with Chart Numbers

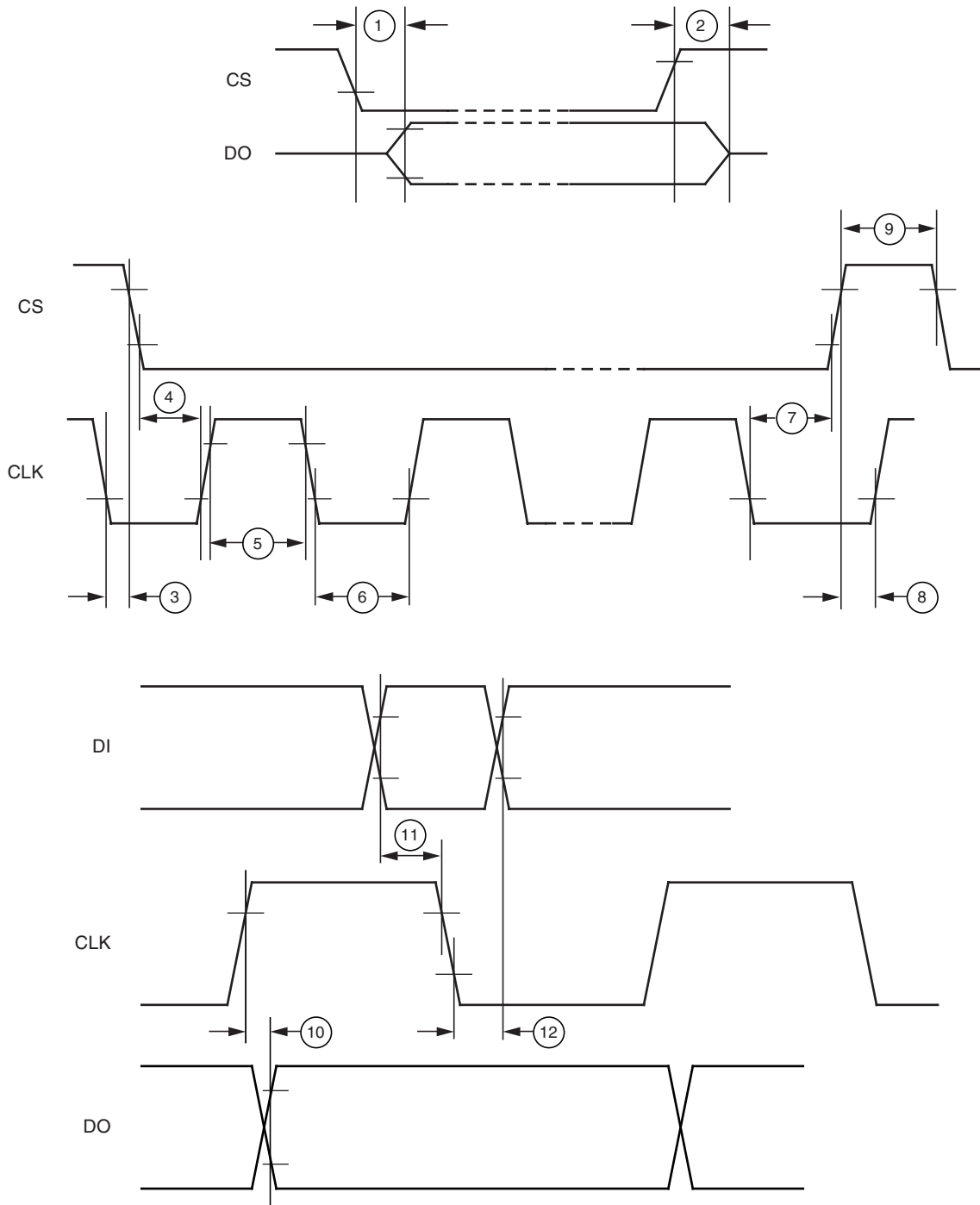

Inputs DI, CLK, CS: High level = $0.7 \times V_{CC}$, low level = $0.3 \times V_{CC}$
 Output DO: High level = $0.8 \times V_{CC}$, low level = $0.2 \times V_{CC}$

10. Application Circuit

Figure 10-1. Application Circuit

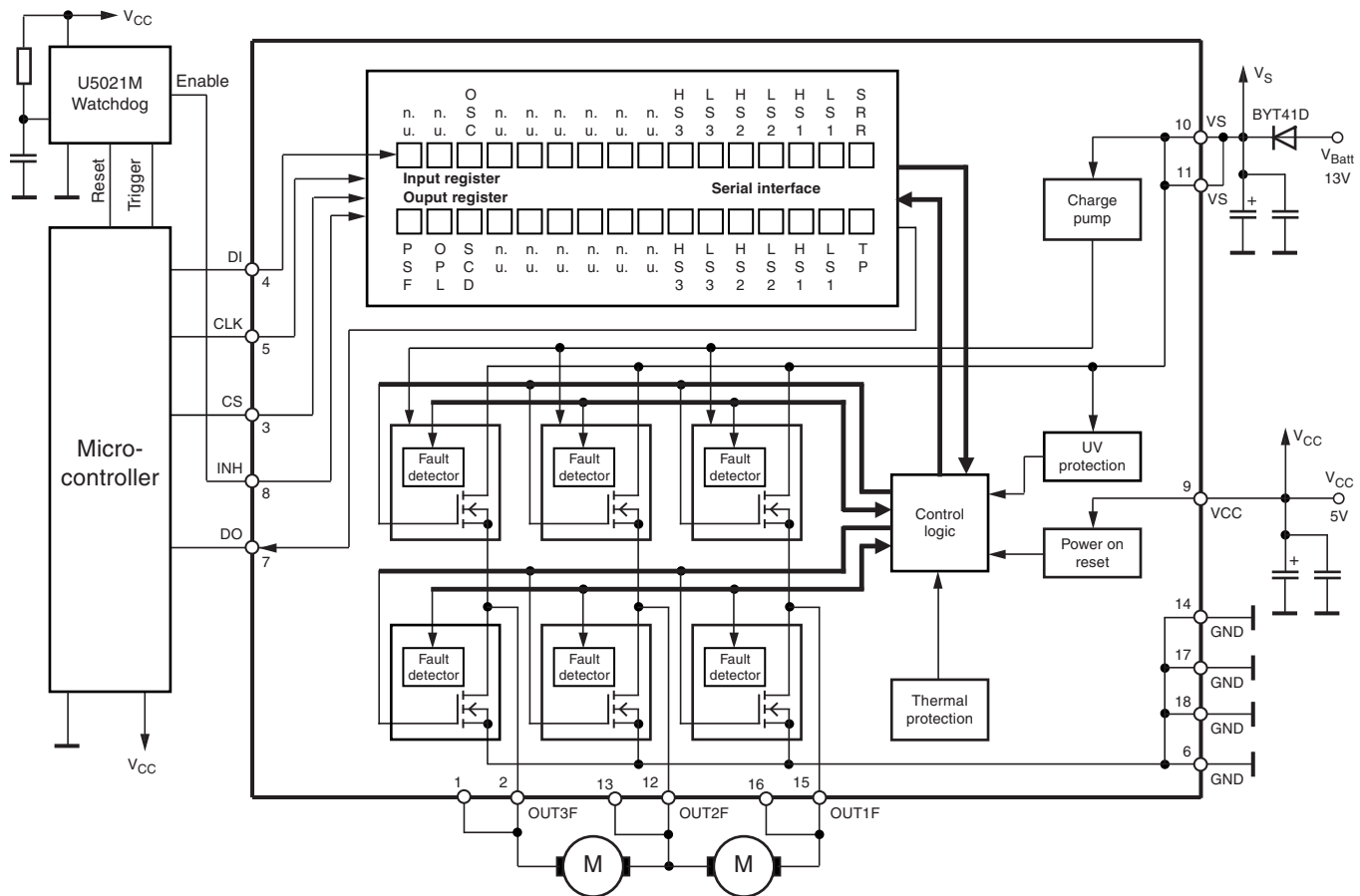

11. Application Notes

It is strongly recommended to connect the blocking capacitors at V_{CC} and V_S as close as possible to the power supply and GND pins.

Recommended value for capacitors at V_S :

Electrolytic capacitor $C > 22 \mu\text{F}$ in parallel with a ceramic capacitor $C = 100 \text{ nF}$. The value for electrolytic capacitor depends on external loads, conducted interferences and reverse conducting current $I_{\text{Out}1,2,3}$ (see Section 4. "Absolute Maximum Ratings" on page 7).

Recommended value for capacitors at V_{CC} :

Electrolytic capacitor $C > 10 \mu\text{F}$ in parallel with a ceramic capacitor $C = 100 \text{ nF}$.

To reduce thermal resistance it is recommended to place cooling areas on the PCB as close as possible to the GND pins and to the die pad.

12. Ordering Information

Extended Type Number	Package	Remarks
ATA6827-PIQW	QFN18, 4 mm × 4 mm	Taped and reeled, Pb-free

13. Package Information

Package: VQFN_4 x 4_18L

Exposed pad 2.7 x 3.175

Dimensions in mm

Not indicated tolerances ± 0.05

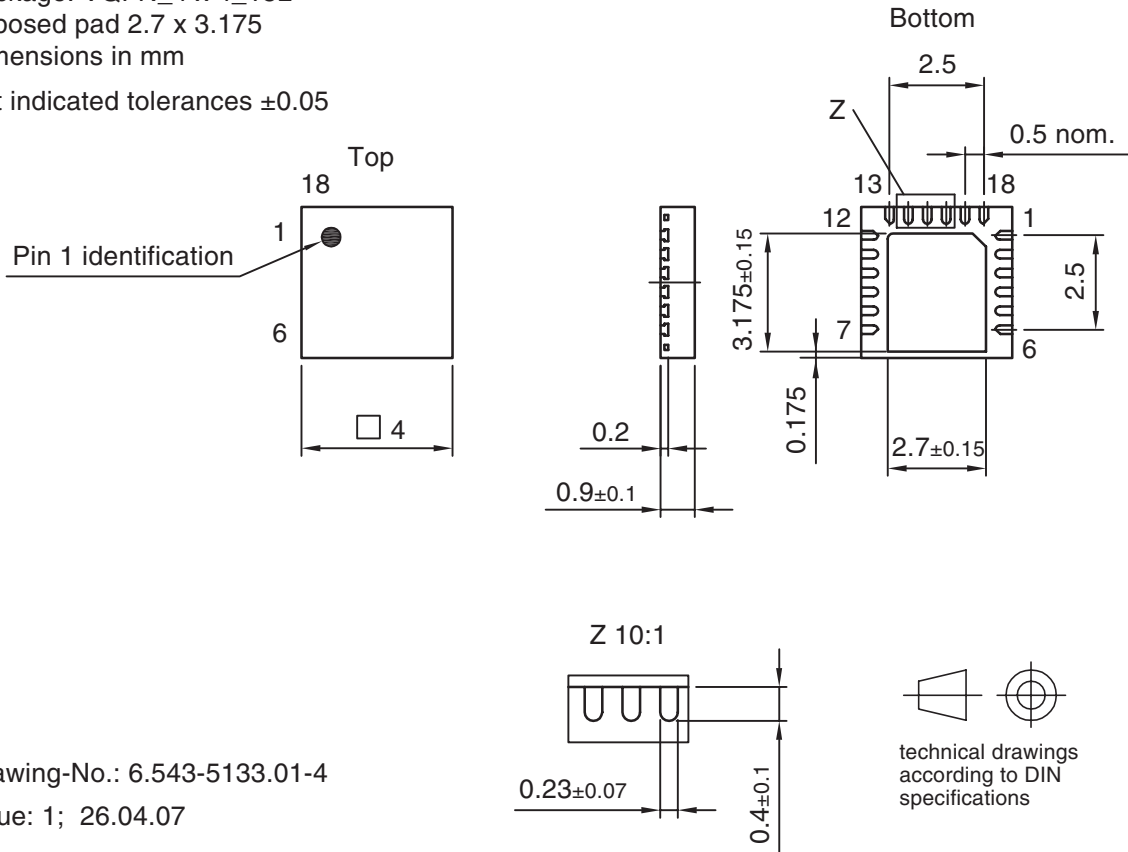

Drawing-No.: 6.543-5133.01-4

Issue: 1; 26.04.07

14. Revision History

Please note that the following page numbers referred to in this section refer to the specific revision mentioned, not to this document.

Revision No.	History
4912D-auto-06/07	<ul style="list-style-type: none"> • Put datasheet in a new template • Package drawing changed • Block diagram changed • Pinning drawing changed • Pin Description table changed • Application circuit drawing changed



Headquarters

Atmel Corporation
2325 Orchard Parkway
San Jose, CA 95131
USA
Tel: 1(408) 441-0311
Fax: 1(408) 487-2600

International

Atmel Asia
Room 1219
Chinachem Golden Plaza
77 Mody Road Tsimshatsui
East Kowloon
Hong Kong
Tel: (852) 2721-9778
Fax: (852) 2722-1369

Atmel Europe
Le Krebs
8, Rue Jean-Pierre Timbaud
BP 309
78054
Saint-Quentin-en-Yvelines Cedex
France
Tel: (33) 1-30-60-70-00
Fax: (33) 1-30-60-71-11

Atmel Japan
9F, Tonetsu Shinkawa Bldg.
1-24-8 Shinkawa
Chuo-ku, Tokyo 104-0033
Japan
Tel: (81) 3-3523-3551
Fax: (81) 3-3523-7581

Product Contact

Web Site
www.atmel.com

Technical Support
auto_drivers@atmel.com

Sales Contact
www.atmel.com/contacts

Literature Requests
www.atmel.com/literature

Disclaimer: The information in this document is provided in connection with Atmel products. No license, express or implied, by estoppel or otherwise, to any intellectual property right is granted by this document or in connection with the sale of Atmel products. **EXCEPT AS SET FORTH IN ATMEL'S TERMS AND CONDITIONS OF SALE LOCATED ON ATMEL'S WEB SITE, ATMEL ASSUMES NO LIABILITY WHATSOEVER AND DISCLAIMS ANY EXPRESS, IMPLIED OR STATUTORY WARRANTY RELATING TO ITS PRODUCTS INCLUDING, BUT NOT LIMITED TO, THE IMPLIED WARRANTY OF MERCHANTABILITY, FITNESS FOR A PARTICULAR PURPOSE, OR NON-INFRINGEMENT. IN NO EVENT SHALL ATMEL BE LIABLE FOR ANY DIRECT, INDIRECT, CONSEQUENTIAL, PUNITIVE, SPECIAL OR INCIDENTAL DAMAGES (INCLUDING, WITHOUT LIMITATION, DAMAGES FOR LOSS OF PROFITS, BUSINESS INTERRUPTION, OR LOSS OF INFORMATION) ARISING OUT OF THE USE OR INABILITY TO USE THIS DOCUMENT, EVEN IF ATMEL HAS BEEN ADVISED OF THE POSSIBILITY OF SUCH DAMAGES.** Atmel makes no representations or warranties with respect to the accuracy or completeness of the contents of this document and reserves the right to make changes to specifications and product descriptions at any time without notice. Atmel does not make any commitment to update the information contained herein. Unless specifically provided otherwise, Atmel products are not suitable for, and shall not be used in, automotive applications. Atmel's products are not intended, authorized, or warranted for use as components in applications intended to support or sustain life.

© 2007 Atmel Corporation. All rights reserved. Atmel®, logo and combinations thereof, and others are registered trademarks or trademarks of Atmel Corporation or its subsidiaries. Other terms and product names may be trademarks of others.