

---

## Features

- Temperature and Supply Voltage Compensated Flashing Frequency
- Frequency Doubling Indicates Lamp Outage
- Relay Driver Output with High Current Carrying Capacity and Low Saturation Voltage
- Minimum Lamp Load for Flasher Operation:  $\geq 1W$
- Very Low Susceptibility to EMI
- Protection According to ISO/TR 7637/1 Level 4



## 1. Description

The bipolar integrated circuit U643B is used in relay-controlled automotive flashers where a high-level EMC is required.

Lamp outage is indicated by frequency doubling during hazard warning as well as direction mode.



---

**Flasher IC with  
30-m $\Omega$  Shunt**

---

**U643B**

Rev. 4727B-AUTO-09/05



## 2. Block Diagram

**Figure 2-1.** Car Flasher Application Circuit, Resistor  $R_1$  and  $R_2$ : 0.25W;  $R_4$  for Protection Against Continuous Reversed Polarity: 0.5W

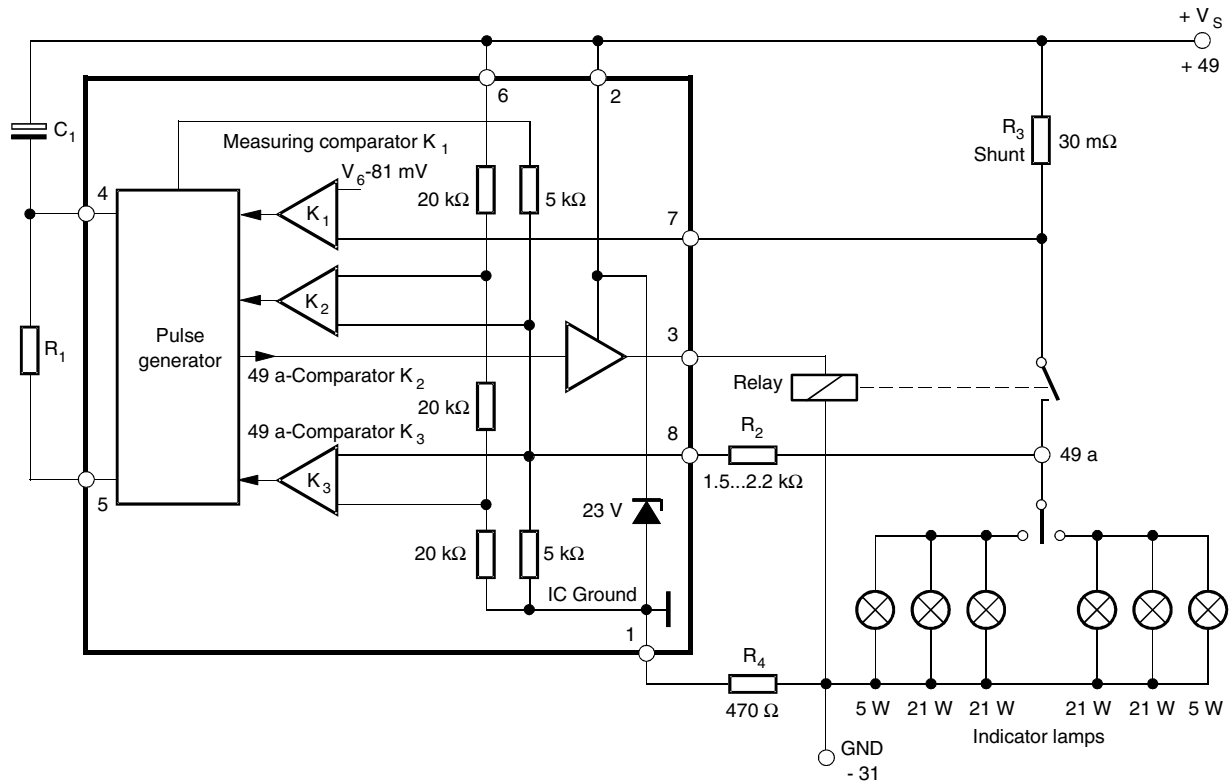

### 3. Pin Configuration

Figure 3-1. Pinning

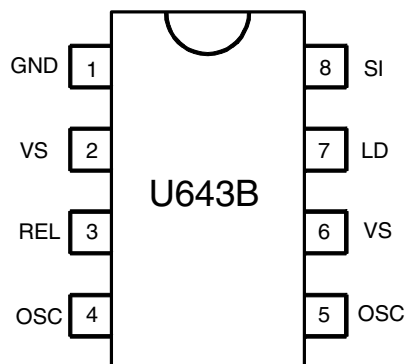

Table 3-1. Pin Description

Pin	Symbol	Function
1	GND	IC ground
2	VS	Supply voltage $V_S$
3	REL	Relay driver
4	OSC	$C_1$ Oscillator
5	OSC	$R_1$ Oscillator
6	VS	Supply voltage $V_S$
7	LD	Lamp failure detection
8	SI	Start input (49a)

## 4. Functional Description

### 4.1 Pin 1, GND

The U643B is protected against damage in case of battery reversal via resistor  $R_4$  to ground (–31). An integrated protection circuit together with external resistances  $R_2$  and  $R_4$  limits the current pulses in the IC.

### 4.2 Pin 2, Supply Voltage, $V_S$ Power

The arrangement of the supply connections to pin 2 must be so as to ensure that on the connection printed circuit board (PCB), the resistance of  $V_S$  to pin 6 is lower than that to pin 2.

### 4.3 Pin 3, Relay Control Output (Driver)

The relay control output is a high-side driver with a low saturation voltage. It is capable of driving a typical automotive relay with a minimum coil resistance of  $60\Omega$ .

### 4.4 Pin 4 and 5, Oscillator

The flashing frequency,  $f_1$ , is determined by the  $R_1C_1$  components as given by the formula below (see [Figure 2-1 on page 2](#)):

$$f_1 \approx \frac{1}{R_1 \times C_1 \times 1.5} \text{ Hz}$$

where  $C_1 \leq 47 \mu\text{F}$ ,  $R_1 = 6.8 \text{ k}\Omega$  to  $510 \text{ k}\Omega$

In case of a lamp outage (see pin 7) the oscillator frequency is switched to the lamp outage frequency  $f_2$  with  $f_2 \approx 2.2 \times f_1$ .

Duty cycle in normal flashing mode: 50%

Duty cycle in lamp outage mode: 40% (bright phase)

### 4.5 Pin 6, Supply Voltage, Sense

For accurate monitoring via the shunt resistor, a minimized layer resistance from point  $V_S$ /shunt to pin 6 is recommended.

## 4.6 Pin 7, Lamp Outage Detection

The lamp current is monitored via an external shunt resistor  $R_3$  and an internal comparator K1 with its reference voltage of typically 81 mV ( $V_S = 12V$ ). The outage of one lamp is detected according to the following calculation:

Nominal current of 1 lamp:  $21W / (V_S = 12V): I_{lamp} = 1.75A$

Nominal current of 2 lamps:  $2 \times 21W / (V_S = 12V): I_{lamp} = 3.5A$ .

The detection threshold should be set in the middle of the current range:

$I_{outage} \approx 2.7A$

Thus, the shunt resistor is calculated as:

$R_3 = V_T (K1) / I_{outage}$

$R_3 = 81 \text{ mV} / 2.7A = 30 \text{ m}\Omega$

Comparator K1's reference voltage is matched to the characteristics of filament lamps (see Control Signal Threshold in ["Electrical Characteristics" on page 6](#)).

The combination of shunt resistor and resistance of wire harness prevents pin 7 from a too high voltage in the case of shorted lamps.

## 4.7 Pin 8, Start Input

Start condition for flashing: the voltage at pin 8 has to be below K3 threshold (flasher switch closed).

Humidity and dirt may decrease the resistance between 49a and GND. If this leakage resistance is  $> 5 \text{ k}\Omega$ , the IC still remains in the OFF condition. In this case the voltage at pin 8 is between the thresholds of comparators K2 and K3.

During the bright phase the voltage at pin 8 is above the K2 threshold, during the dark phase it is below the K3 threshold. For proper start conditions a minimum lamp wattage of 1W is required.

## 5. Absolute Maximum Ratings

Stresses beyond those listed under “Absolute Maximum Ratings” may cause permanent damage to the device. This is a stress rating only and functional operation of the device at these or any other conditions beyond those indicated in the operational sections of this specification is not implied. Exposure to absolute maximum rating conditions for extended periods may affect device reliability.

Reference point pin 1

Parameters		Symbol	Value	Unit
Supply voltage	Pins 2 and 6	$V_S$	16.5	V
<b>Surge Forward Current</b>				
$t_p = 0.1$ ms	Pins 2 and 6	$I_{FSM}$	1.5	A
$t_p = 300$ ms	Pins 2 and 6	$I_{FSM}$	1.0	A
$t_p = 300$ ms	Pin 8	$I_{FSM}$	50	mA
Output current	Pin 3	$I_O$	0.3	A
<b>Power Dissipation</b>				
$T_{amb} = 95^\circ\text{C}$	DIP 8	$P_{tot}$	420	mW
	SO8	$P_{tot}$	340	mW
$T_{amb} = 60^\circ\text{C}$	DIP 8	$P_{tot}$	690	mW
	SO8	$P_{tot}$	560	mW
Junction temperature		$T_J$	150	$^\circ\text{C}$
Ambient temperature range		$T_{amb}$	-40 to +95	$^\circ\text{C}$
Storage temperature range		$T_{stg}$	-55 to +150	$^\circ\text{C}$

## 6. Thermal Resistance

Parameters		Symbol	Value	Unit
Junction ambient	DIP8	$R_{thJA}$	110	K/W
	SO8	$R_{thJA}$	160	K/W

## 7. Electrical Characteristics

Typical values under normal operation in application circuit (see [Figure 2-1 on page 2](#)),  $V_S (+49, \text{pin 2 and 6}) = 12\text{V}$ .

Reference point ground (-31),  $T_{amb} = 25^\circ\text{C}$ , unless otherwise specified.

Parameters	Test Conditions	Symbol	Min.	Typ.	Max.	Unit
Supply voltage range	Pins 2 and 6	$V_S (+49)$		9 to 15		V
Supply current	Pins 2 and 6 Dark phase Bright phase	$I_S$		4.5	8	mA
		$I_S$		7.0	11	mA
Relay output: Saturation voltage	Pin 3 $I_O = 150$ mA, $V_S = 9\text{V}$ with resistance = $60\Omega$	$V_O$			1.0	V
Reverse current		$I_O$			0.1	mA
Start delay	First bright phase	$t_{on}$			10	ms
Frequency tolerance		$\delta f_1$	-5		+5	%
Bright period	Basic frequency $f_1$ Control frequency $f_2$	$\Delta f_1$	47		53	%
		$\Delta f_2$	37		45	%
Frequency increase	Lamp outage	$f_2$	$2.15 f_1$		$2.3 f_1$	Hz
Control signal threshold	$V_S = 15\text{V}$ , pin 7	$V_{R3}$	85	91	97	mV
	$V_S = 9\text{V}$ , pin 7	$V_{R3}$	66	71	76	mV
	$V_S = 12\text{V}$ , pin 7	$V_{R3}$	76	81	87	mV
Leakage resistance	49a to GND	$R_P$		4	5	k $\Omega$
Lamp load		$P_L$	1			W

## 8. Ordering Information

Extended Type Number	Package	Remarks
U643B-MY	DIP8	Pb-free
U643B-MFPY	SO8	Tubed, Pb-free
U643B-MFPG3Y	SO8	Taped and reeled, Pb-free

## 9. Package Information

### 9.1 DIP8

Package: DIP 8  
Dimensions in mm

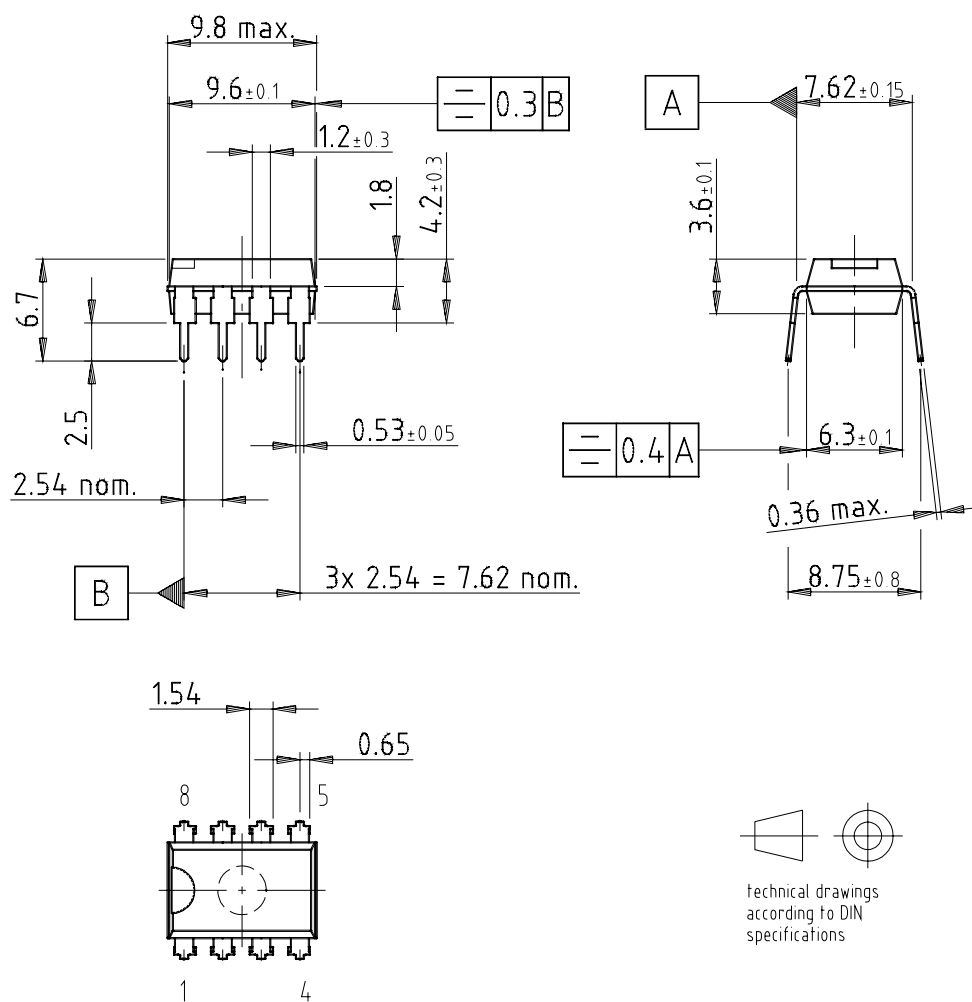

Drawing-No.: 6.543-5040.01-4  
Issue: 1; 16.01.02

## 9.2 SO8

### Package SO8

Dimensions in mm

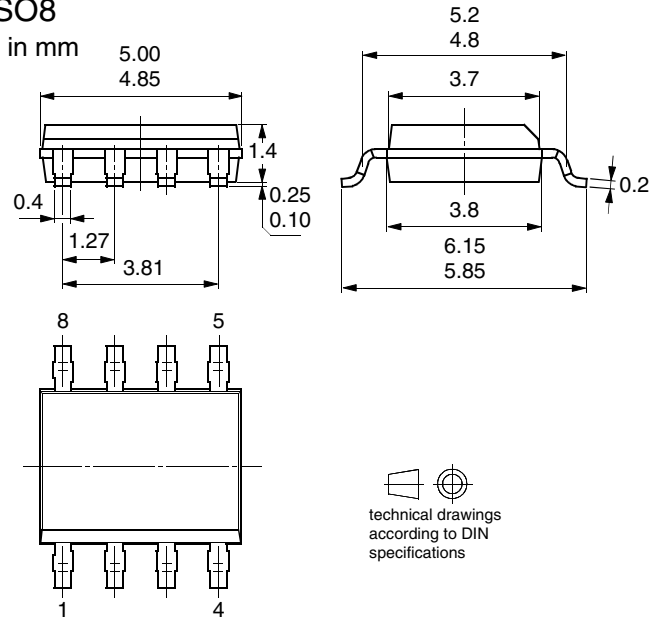

## 10. Revision History

Please note that the following page numbers referred to in this section refer to the specific revision mentioned, not to this document.

Revision No.	History
4727B-AUTO-09/05	<ul style="list-style-type: none"> <li>• Put datasheet in a new template</li> <li>• Updated text to new style guide</li> <li>• First page: Pb-free logo added</li> <li>• Page 6: Ordering Information changed</li> </ul>





## Atmel Corporation

2325 Orchard Parkway  
San Jose, CA 95131, USA  
Tel: 1(408) 441-0311  
Fax: 1(408) 487-2600

## Regional Headquarters

### Europe

Atmel Sarl  
Route des Arsenaux 41  
Case Postale 80  
CH-1705 Fribourg  
Switzerland  
Tel: (41) 26-426-5555  
Fax: (41) 26-426-5500

### Asia

Room 1219  
Chinachem Golden Plaza  
77 Mody Road Tsimshatsui  
East Kowloon  
Hong Kong  
Tel: (852) 2721-9778  
Fax: (852) 2722-1369

### Japan

9F, Tonetsu Shinkawa Bldg.  
1-24-8 Shinkawa  
Chuo-ku, Tokyo 104-0033  
Japan  
Tel: (81) 3-3523-3551  
Fax: (81) 3-3523-7581

## Atmel Operations

### Memory

2325 Orchard Parkway  
San Jose, CA 95131, USA  
Tel: 1(408) 441-0311  
Fax: 1(408) 436-4314

### Microcontrollers

2325 Orchard Parkway  
San Jose, CA 95131, USA  
Tel: 1(408) 441-0311  
Fax: 1(408) 436-4314

La Chantrerie  
BP 70602  
44306 Nantes Cedex 3, France  
Tel: (33) 2-40-18-18-18  
Fax: (33) 2-40-18-19-60

### ASIC/ASSP/Smart Cards

Zone Industrielle  
13106 Rousset Cedex, France  
Tel: (33) 4-42-53-60-00  
Fax: (33) 4-42-53-60-01

1150 East Cheyenne Mtn. Blvd.  
Colorado Springs, CO 80906, USA  
Tel: 1(719) 576-3300  
Fax: 1(719) 540-1759

Scottish Enterprise Technology Park  
Maxwell Building  
East Kilbride G75 0QR, Scotland  
Tel: (44) 1355-803-000  
Fax: (44) 1355-242-743

### RF/Automotive

Theresienstrasse 2  
Postfach 3535  
74025 Heilbronn, Germany  
Tel: (49) 71-31-67-0  
Fax: (49) 71-31-67-2340

1150 East Cheyenne Mtn. Blvd.  
Colorado Springs, CO 80906, USA  
Tel: 1(719) 576-3300  
Fax: 1(719) 540-1759

### Biometrics/Imaging/Hi-Rel MPU/ High Speed Converters/RF Datacom

Avenue de Rochepleine  
BP 123  
38521 Saint-Egreve Cedex, France  
Tel: (33) 4-76-58-30-00  
Fax: (33) 4-76-58-34-80

---

### Literature Requests

[www.atmel.com/literature](http://www.atmel.com/literature)

**Disclaimer:** The information in this document is provided in connection with Atmel products. No license, express or implied, by estoppel or otherwise, to any intellectual property right is granted by this document or in connection with the sale of Atmel products. **EXCEPT AS SET FORTH IN ATMEL'S TERMS AND CONDITIONS OF SALE LOCATED ON ATMEL'S WEB SITE, ATMEL ASSUMES NO LIABILITY WHATSOEVER AND DISCLAIMS ANY EXPRESS, IMPLIED OR STATUTORY WARRANTY RELATING TO ITS PRODUCTS INCLUDING, BUT NOT LIMITED TO, THE IMPLIED WARRANTY OF MERCHANTABILITY, FITNESS FOR A PARTICULAR PURPOSE, OR NON-INFRINGEMENT. IN NO EVENT SHALL ATMEL BE LIABLE FOR ANY DIRECT, INDIRECT, CONSEQUENTIAL, PUNITIVE, SPECIAL OR INCIDENTAL DAMAGES (INCLUDING, WITHOUT LIMITATION, DAMAGES FOR LOSS OF PROFITS, BUSINESS INTERRUPTION, OR LOSS OF INFORMATION) ARISING OUT OF THE USE OR INABILITY TO USE THIS DOCUMENT, EVEN IF ATMEL HAS BEEN ADVISED OF THE POSSIBILITY OF SUCH DAMAGES.** Atmel makes no representations or warranties with respect to the accuracy or completeness of the contents of this document and reserves the right to make changes to specifications and product descriptions at any time without notice. Atmel does not make any commitment to update the information contained herein. Unless specifically provided otherwise, Atmel products are not suitable for, and shall not be used in, automotive applications. Atmel's products are not intended, authorized, or warranted for use as components in applications intended to support or sustain life.

© Atmel Corporation 2005. All rights reserved. Atmel®, logo and combinations thereof, Everywhere You Are® and others, are registered trademarks or trademarks of Atmel Corporation or its subsidiaries. Other terms and product names may be trademarks of others.



Printed on recycled paper.

4727B-AUTO-09/05