



# ±15kV ESD-Protected, +5V RS-232 Transceivers

## General Description

The MAX202E–MAX213E, MAX232E/MAX241E line drivers/receivers are designed for RS-232 and V.28 communications in harsh environments. Each transmitter output and receiver input is protected against ±15kV electrostatic discharge (ESD) shocks, without latching. The various combinations of features are outlined in the *Selector Guide*. The drivers and receivers for all ten devices meet all EIA/TIA-232E and CCITT V.28 specifications at data rates up to 120kbps, when loaded in accordance with the EIA/TIA-232E specification.

The MAX211E/MAX213E/MAX241E are available in 28-pin SO packages, as well as a 28-pin SSOP that uses 60% less board space. The MAX202E/MAX232E come in 16-pin TSSOP, narrow SO, wide SO, and DIP packages. The MAX203E comes in a 20-pin DIP/SO package, and needs no external charge-pump capacitors. The MAX205E comes in a 24-pin wide DIP package, and also eliminates external charge-pump capacitors. The MAX206E/MAX207E/MAX208E come in 24-pin SO, SSOP, and narrow DIP packages. The MAX232E/MAX241E operate with four 1µF capacitors, while the MAX202E/MAX206E/MAX207E/MAX208E/MAX211E/MAX213E operate with four 0.1µF capacitors, further reducing cost and board space.

## Applications

Notebook, Subnotebook, and Palmtop Computers  
Battery-Powered Equipment  
Hand-Held Equipment

## Next-Generation Device Features

- ◆ For Low-Voltage Applications  
MAX3222E/MAX3232E/MAX3237E/MAX3241E/  
MAX3246E: ±15kV ESD-Protected Down to  
10nA, +3.0V to +5.5V, Up to 1Mbps, True RS-232  
Transceivers (MAX3246E Available in a UCSP™  
Package)
- ◆ For Low-Power Applications  
MAX3221/MAX3223/MAX3243: 1µA Supply  
Current, True +3V to +5.5V RS-232 Transceivers  
with Auto-Shutdown™
- ◆ For Space-Constrained Applications  
MAX3233E/MAX3235E: ±15kV ESD-Protected,  
1µA, 250kbps, +3.0V/+5.5V, Dual RS-232  
Transceivers with Internal Capacitors
- ◆ For Low-Voltage or Data Cable Applications  
MAX3380E/MAX3381E: +2.35V to +5.5V, 1µA,  
2Tx/2Rx RS-232 Transceivers with ±15kV ESD-  
Protected I/O and Logic Pins

Ordering Information, Pin Configurations, and Typical  
Operating Circuits appear at end of data sheet.

AutoShutdown and UCSP are trademarks of Maxim Integrated  
Products, Inc.

## Selector Guide

PART	NO. OF RS-232 DRIVERS	NO. OF RS-232 RECEIVERS	RECEIVERS ACTIVE IN SHUTDOWN	NO. OF EXTERNAL CAPACITORS (µF)	LOW-POWER SHUTDOWN	TTL TRI-STATE
MAX202E	2	2	0	4 (0.1)	No	No
MAX203E	2	2	0	None	No	No
MAX205E	5	5	0	None	Yes	Yes
MAX206E	4	3	0	4 (0.1)	Yes	Yes
MAX207E	5	3	0	4 (0.1)	No	No
MAX208E	4	4	0	4 (0.1)	No	No
MAX211E	4	5	0	4 (0.1)	Yes	Yes
MAX213E	4	5	2	4 (0.1)	Yes	Yes
MAX232E	2	2	0	4 (1)	No	No
MAX241E	4	5	0	4 (1)	Yes	Yes



For pricing, delivery, and ordering information, please contact Maxim/Dallas Direct! at  
1-888-629-4642, or visit Maxim's website at [www.maxim-ic.com](http://www.maxim-ic.com).

# ±15kV ESD-Protected, +5V RS-232 Transceivers

## ABSOLUTE MAXIMUM RATINGS

V <sub>CC</sub> .....	-0.3V to +6V	20-Pin Plastic DIP (derate 11.11mW/°C above +70°C)...	889mW
V <sub>+</sub> .....	(V <sub>CC</sub> - 0.3V) to +14V	20-Pin SO (derate 10.00mW/°C above +70°C).....	800mW
V <sub>-</sub> .....	-14V to +0.3V	24-Pin Narrow Plastic DIP	
Input Voltages		(derate 13.33mW/°C above +70°C) .....	1.07W
T <sub>IN</sub> .....	-0.3V to (V <sub>+</sub> + 0.3V)	24-Pin Wide Plastic DIP	
R <sub>IN</sub> .....	±30V	(derate 14.29mW/°C above +70°C).....	1.14W
Output Voltages		24-Pin SO (derate 11.76mW/°C above +70°C).....	941mW
T <sub>OUT</sub> .....	(V <sub>-</sub> - 0.3V) to (V <sub>+</sub> + 0.3V)	24-Pin SSOP (derate 8.00mW/°C above +70°C) .....	640mW
R <sub>OUT</sub> .....	-0.3V to (V <sub>CC</sub> + 0.3V)	28-Pin SO (derate 12.50mW/°C above +70°C).....	1W
Short-Circuit Duration, T <sub>OUT</sub> .....	Continuous	28-Pin SSOP (derate 9.52mW/°C above +70°C) .....	762mW
Continuous Power Dissipation (T <sub>A</sub> = +70°C)		Operating Temperature Ranges	
16-Pin Plastic DIP (derate 10.53mW/°C above +70°C)....	842mW	MAX2_EC_.....	0°C to +70°C
16-Pin Narrow SO (derate 8.70mW/°C above +70°C) .....	696mW	MAX2_EE_.....	-40°C to +85°C
16-Pin Wide SO (derate 9.52mW/°C above +70°C) .....	762mW	Storage Temperature Range .....	-65°C to +165°C
16-Pin TSSOP (derate 9.4mW/°C above +70°C) .....	755mW	Lead Temperature (soldering, 10sec) .....	+300°C

Stresses beyond those listed under "Absolute Maximum Ratings" may cause permanent damage to the device. These are stress ratings only, and functional operation of the device at these or any other conditions beyond those indicated in the operational sections of the specifications is not implied. Exposure to absolute maximum rating conditions for extended periods may affect device reliability.

## ELECTRICAL CHARACTERISTICS

(V<sub>CC</sub> = +5V ±10% for MAX202E/206E/208E/211E/213E/232E/241E; V<sub>CC</sub> = +5V ±5% for MAX203E/205E/207E; C1-C4 = 0.1µF for MAX202E/206E/207E/208E/211E/213E; C1-C4 = 1µF for MAX232E/241E; T<sub>A</sub> = T<sub>MIN</sub> to T<sub>MAX</sub>; unless otherwise noted. Typical values are at T<sub>A</sub> = +25°C.)

PARAMETER	SYMBOL	CONDITIONS	MIN	TYP	MAX	UNITS
<b>DC CHARACTERISTICS</b>						
V <sub>CC</sub> Supply Current	I <sub>CC</sub>	No load, T <sub>A</sub> = +25°C	MAX202E/203E	8	15	mA
			MAX205E-208E	11	20	
			MAX211E/213E	14	20	
			MAX232E	5	10	
			MAX241E	7	15	
Shutdown Supply Current		T <sub>A</sub> = +25°C, Figure 1	MAX205E/206E	1	10	µA
			MAX211E/241E	1	10	
			MAX213E	15	50	
<b>LOGIC</b>						
Input Pull-Up Current		T <sub>IN</sub> = 0V (MAX205E-208E/211E/213E/241E)		15	200	µA
Input Leakage Current		T <sub>IN</sub> = 0V to V <sub>CC</sub> (MAX202E/203E/232E)			±10	µA
Input Threshold Low	V <sub>IL</sub>	T <sub>IN</sub> ; EN, $\overline{\text{SHDN}}$ (MAX213E) or $\overline{\text{EN}}$ , SHDN (MAX205E-208E/211E/241E)			0.8	V
Input Threshold High	V <sub>IH</sub>	T <sub>IN</sub>	2.0			V
		EN, $\overline{\text{SHDN}}$ (MAX213E) or $\overline{\text{EN}}$ , SHDN (MAX205E-208E/211E/241E)	2.4			
Output Voltage Low	V <sub>OL</sub>	R <sub>OUT</sub> ; I <sub>OUT</sub> = 3.2mA (MAX202E/203E/232E) or I <sub>OUT</sub> = 1.6mA (MAX205E/208E/211E/213E/241E)			0.4	V
Output Voltage High	V <sub>OH</sub>	R <sub>OUT</sub> ; I <sub>OUT</sub> = -1.0mA	3.5	V <sub>CC</sub> - 0.4		V
Output Leakage Current		$\overline{\text{EN}}$ = V <sub>CC</sub> , EN = 0V, 0V ≤ R <sub>OUT</sub> ≤ V <sub>CC</sub> , MAX205E-208E/211E/213E/241E outputs disabled		±0.05	±10	µA

# ±15kV ESD-Protected, +5V RS-232 Transceivers

MAX202E-MAX213E, MAX232E/MAX241E

## ELECTRICAL CHARACTERISTICS (continued)

(V<sub>CC</sub> = +5V ±10% for MAX202E/206E/208E/211E/213E/232E/241E; V<sub>CC</sub> = +5V ±5% for MAX203E/205E/207E; C<sub>1</sub>-C<sub>4</sub> = 0.1µF for MAX202E/206E/207E/208E/211E/213E; C<sub>1</sub>-C<sub>4</sub> = 1µF for MAX232E/241E; T<sub>A</sub> = T<sub>MIN</sub> to T<sub>MAX</sub>; unless otherwise noted. Typical values are at T<sub>A</sub> = +25°C.)

PARAMETER	SYMBOL	CONDITIONS	MIN	TYP	MAX	UNITS	
<b>EIA/TIA-232E RECEIVER INPUTS</b>							
Input Voltage Range			-30		30	V	
Input Threshold Low		T <sub>A</sub> = +25°C, V <sub>CC</sub> = 5V	All parts, normal operation		0.8	1.2	V
			MAX213E, $\overline{\text{SHDN}} = 0\text{V}$ , EN = V <sub>CC</sub>		0.6	1.5	
Input Threshold High		T <sub>A</sub> = +25°C, V <sub>CC</sub> = 5V	All parts, normal operation		1.7	2.4	V
			MAX213E (R4, R5), $\overline{\text{SHDN}} = 0\text{V}$ , EN = V <sub>CC</sub>		1.5	2.4	
Input Hysteresis		V <sub>CC</sub> = 5V, no hysteresis in shutdown	0.2	0.5	1.0	V	
Input Resistance		T <sub>A</sub> = +25°C, V <sub>CC</sub> = 5V	3	5	7	kΩ	
<b>EIA/TIA-232E TRANSMITTER OUTPUTS</b>							
Output Voltage Swing		All drivers loaded with 3kΩ to ground (Note 1)	±5	±9		V	
Output Resistance		V <sub>CC</sub> = V <sub>+</sub> = V <sub>-</sub> = 0V, V <sub>OUT</sub> = ±2V	300			Ω	
Output Short-Circuit Current				±10	±60	mA	
<b>TIMING CHARACTERISTICS</b>							
Maximum Data Rate		R <sub>L</sub> = 3kΩ to 7kΩ, C <sub>L</sub> = 50pF to 1000pF, one transmitter switching	120			kbps	
Receiver Propagation Delay	t <sub>PLHR</sub> , t <sub>PHLR</sub>	C <sub>L</sub> = 150pF	All parts, normal operation		0.5	10	µs
			MAX213E (R4, R5), $\overline{\text{SHDN}} = 0\text{V}$ , EN = V <sub>CC</sub>		4	40	
Receiver Output Enable Time		MAX205E/206E/211E/213E/241E normal operation, Figure 2		600		ns	
Receiver Output Disable Time		MAX205E/206E/211E/213E/241E normal operation, Figure 2		200		ns	
Transmitter Propagation Delay	t <sub>PLHT</sub> , t <sub>PHLT</sub>	R <sub>L</sub> = 3kΩ, C <sub>L</sub> = 2500pF, all transmitters loaded		2		µs	
Transition-Region Slew Rate		T <sub>A</sub> = +25°C, V <sub>CC</sub> = 5V, R <sub>L</sub> = 3kΩ to 7kΩ, C <sub>L</sub> = 50pF to 1000pF, measured from -3V to +3V or +3V to -3V, Figure 3	3	6	30	V/µs	
<b>ESD PERFORMANCE: TRANSMITTER OUTPUTS, RECEIVER INPUTS</b>							
ESD-Protection Voltage		Human Body Model		±15		kV	
		IEC1000-4-2, Contact Discharge		±8			
		IEC1000-4-2, Air-Gap Discharge		±15			

**Note 1:** MAX211EE\_ \_ tested with V<sub>CC</sub> = +5V ±5%.

# ±15kV ESD-Protected, +5V RS-232 Transceivers

## Typical Operating Characteristics

(Typical Operating Circuits,  $V_{CC} = +5V$ ,  $T_A = +25^\circ C$ , unless otherwise noted.)

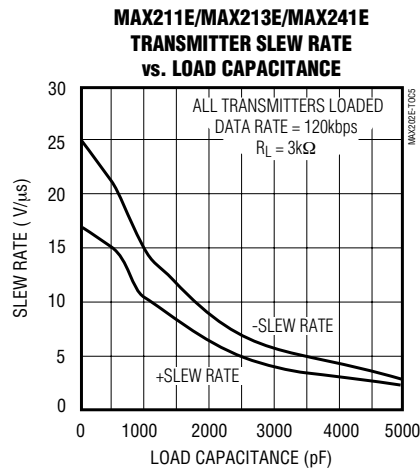
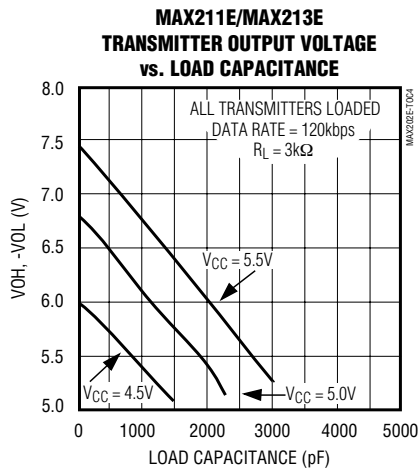
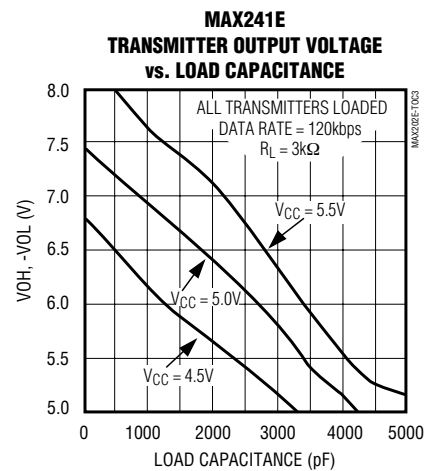
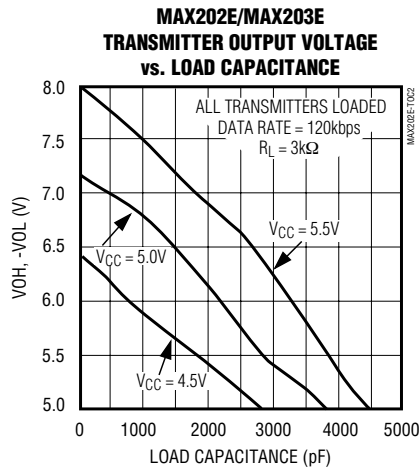
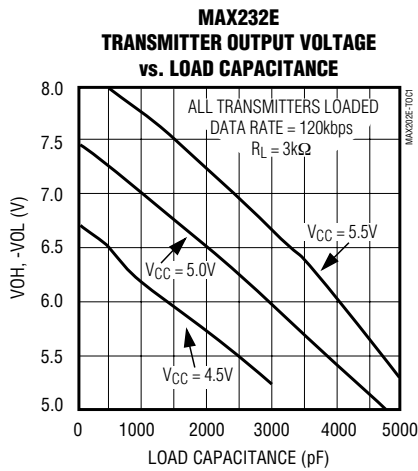

# ±15kV ESD-Protected, +5V RS-232 Transceivers

## Typical Operating Characteristics (continued)

(Typical Operating Circuits,  $V_{CC} = +5V$ ,  $T_A = +25^\circ C$ , unless otherwise noted.)

MAX202E-MAX213E, MAX232E/MAX241E

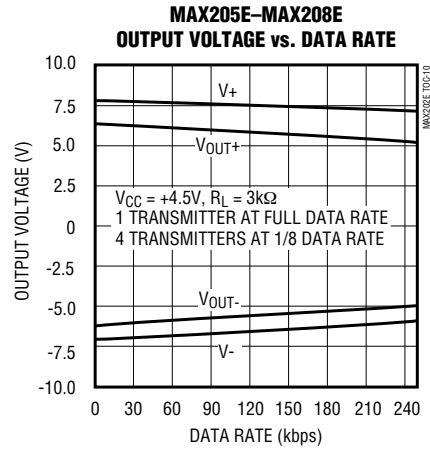
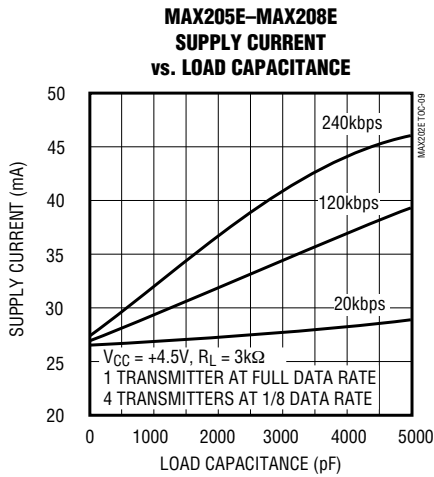
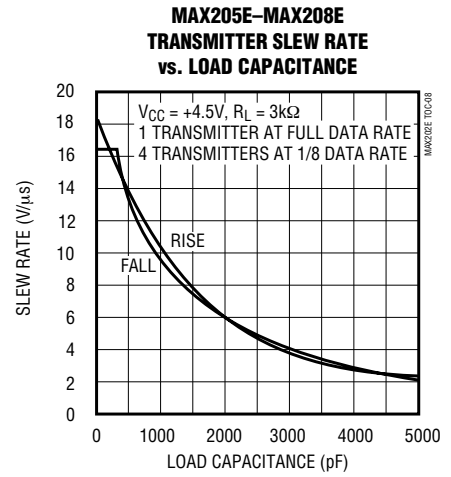
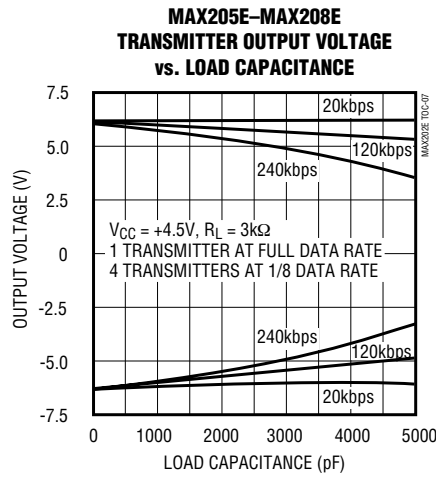
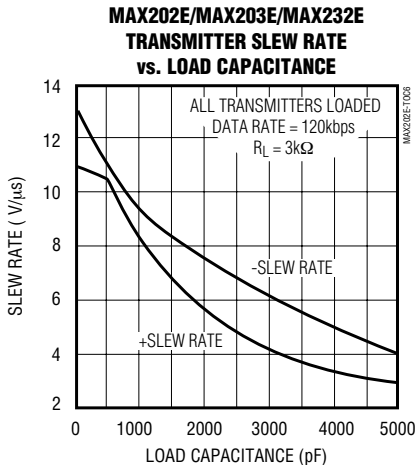

# ±15kV ESD-Protected, +5V RS-232 Transceivers

## Pin Descriptions

### MAX202E/MAX232E

PIN		NAME	FUNCTION
DIP/SOT/SSOP	LCC		
1, 3	2, 4	C1+, C1-	Terminals for positive charge-pump capacitor
2	3	V+	+2V <sub>CC</sub> voltage generated by the charge pump
4, 5	5, 7	C2+, C2-	Terminals for negative charge-pump capacitor
6	8	V-	-2V <sub>CC</sub> voltage generated by the charge pump
7, 14	9, 18	T_OUT	RS-232 Driver Outputs
8, 13	10, 17	R_IN	RS-232 Receiver Outputs
9, 12	12, 15	R_OUT	RS-232 Receiver Outputs
10, 11	13, 14	T_IN	RS-232 Driver Inputs
15	19	GND	Ground
16	20	V <sub>CC</sub>	+4.5V to +5.5V Supply-Voltage Input
—	1, 6, 11, 16	N.C.	No Connect—not internally connected.

### MAX203E

PIN		NAME	FUNCTION
DIP	SO		
1, 2	1, 2	T_IN	RS-232 Driver Inputs
3, 20	3, 20	R_OUT	RS-232 Receiver Outputs
4, 19	4, 19	R_IN	RS-232 Receiver Inputs
5, 18	5, 18	T_OUT	RS-232 Transmitter Outputs
6, 9	6, 9	GND	Ground
7	7	V <sub>CC</sub>	+4.5V to +5.5V Supply-Voltage Input
8	13	C1+	Make no connection to this pin.
10, 16	11, 16	C2-	Connect pins together.
12, 17	10, 17	V-	-2V <sub>CC</sub> voltage generated by the charge pump. Connect pins together.
13	14	C1-	Make no connection to this pin.
14	8	V+	+2V <sub>CC</sub> voltage generated by the charge pump
11, 15	12, 15	C2+	Connect pins together.

### MAX205E

PIN	NAME	FUNCTION
1–4, 19	T_OUT	RS-232 Driver Outputs
5, 10, 13, 18, 24	R_IN	RS-232 Receiver Inputs
6, 9, 14, 17, 23	R_OUT	TTL/CMOS Receiver Outputs. All receivers are inactive in shutdown.
7, 8, 15, 16, 22	T_IN	TTL/CMOS Driver Inputs. Internal pull-ups to V <sub>CC</sub> .
11	GND	Ground
12	V <sub>CC</sub>	+4.75V to +5.25V Supply Voltage
20	$\overline{\text{EN}}$	Receiver Enable—active low
21	SHDN	Shutdown Control—active high

# ±15kV ESD-Protected, +5V RS-232 Transceivers

## Pin Descriptions (continued)

### MAX206E

PIN	NAME	FUNCTION
1, 2, 3, 24	T_OUT	RS-232 Driver Outputs
4, 16, 23	R_IN	RS-232 Receiver Inputs
5, 17, 22	R_OUT	TTL/CMOS Receiver Outputs. All receivers are inactive in shutdown.
6, 7, 18, 19	T_IN	TTL/CMOS Driver Inputs. Internal pull-ups to V <sub>CC</sub> .
8	GND	Ground
9	V <sub>CC</sub>	+4.5V to +5.5V Supply Voltage
10, 12	C1+, C1-	Terminals for positive charge-pump capacitor
11	V+	+2V <sub>CC</sub> generated by the charge pump
13, 14	C2+, C2-	Terminals for negative charge-pump capacitor
15	V-	-2V <sub>CC</sub> generated by the charge pump
20	$\overline{\text{EN}}$	Receiver Enable—active low
21	SHDN	Shutdown Control—active high

### MAX207E

PIN	NAME	FUNCTION
1, 2, 3, 20, 24	T_OUT	RS-232 Driver Outputs
4, 16, 23	R_IN	RS-232 Receiver Inputs
5, 17, 22	R_OUT	TTL/CMOS Receiver Outputs. All receivers are inactive in shutdown.
6, 7, 18, 19, 21	T_IN	TTL/CMOS Driver Inputs. Internal pull-ups to V <sub>CC</sub> .
8	GND	Ground
9	V <sub>CC</sub>	+4.75V to +5.25V Supply Voltage
10, 12	C1+, C1-	Terminals for positive charge-pump capacitor
11	V+	+2V <sub>CC</sub> generated by the charge pump
13, 14	C2+, C2-	Terminals for negative charge-pump capacitor
15	V-	-2V <sub>CC</sub> generated by the charge pump

### MAX208E

PIN	NAME	FUNCTION
1, 2, 20, 24	T_OUT	RS-232 Driver Outputs
3, 7, 16, 23	R_IN	RS-232 Receiver Inputs
4, 6, 17, 22	R_OUT	TTL/CMOS Receiver Outputs. All receivers are inactive in shutdown.
5, 18, 19, 21	T_IN	TTL/CMOS Driver Inputs. Internal pull-ups to V <sub>CC</sub> .
8	GND	Ground
9	V <sub>CC</sub>	+4.5V to +5.5V Supply Voltage
10, 12	C1+, C1-	Terminals for positive charge-pump capacitor
11	V+	+2V <sub>CC</sub> generated by the charge pump
13, 14	C2+, C2-	Terminals for negative charge-pump capacitor
15	V-	-2V <sub>CC</sub> generated by the charge pump

MAX202E-MAX213E, MAX232E/MAX241E

# ±15kV ESD-Protected, +5V RS-232 Transceivers

## Pin Descriptions (continued)

### MAX211E/MAX213E/MAX241E

PIN	NAME	FUNCTION
1, 2, 3, 28	T_OUT	RS-232 Driver Outputs
4, 9, 18, 23, 27	R_IN	RS-232 Receiver Inputs
5, 8, 19, 22, 26	R_OUT	TTL/CMOS Receiver Outputs. For the MAX213E, receivers R4 and R5 are active in shutdown mode when EN = 1. For the MAX211E and MAX241E, all receivers are inactive in shutdown.
6, 7, 20, 21	T_IN	TTL/CMOS Driver Inputs. Only the MAX211E, MAX213E, and MAX241E have internal pull-ups to V <sub>CC</sub> .
10	GND	Ground
11	V <sub>CC</sub>	+4.5V to +5.5V Supply Voltage
12, 14	C1+, C1-	Terminals for positive charge-pump capacitor
13	V+	+2V <sub>CC</sub> voltage generated by the charge pump
15, 16	C2+, C2-	Terminals for negative charge-pump capacitor
17	V-	-2V <sub>CC</sub> voltage generated by the charge pump
24	$\overline{\text{EN}}$	Receiver Enable—active low (MAX211E, MAX241E)
	EN	Receiver Enable—active high (MAX213E)
25	SHDN	Shutdown Control—active high (MAX211E, MAX241E)
	$\overline{\text{SHDN}}$	Shutdown Control—active low (MAX213E)

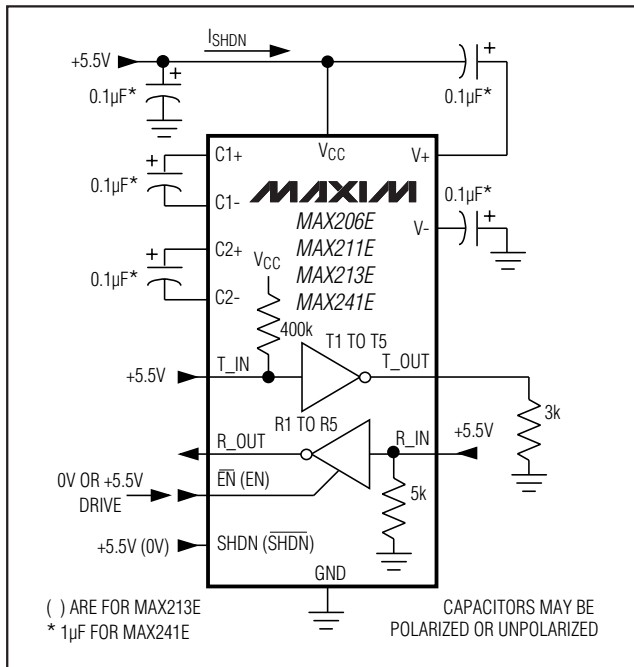

Figure 1. Shutdown-Current Test Circuit (MAX206E, MAX211E/MAX213E/MAX241E)

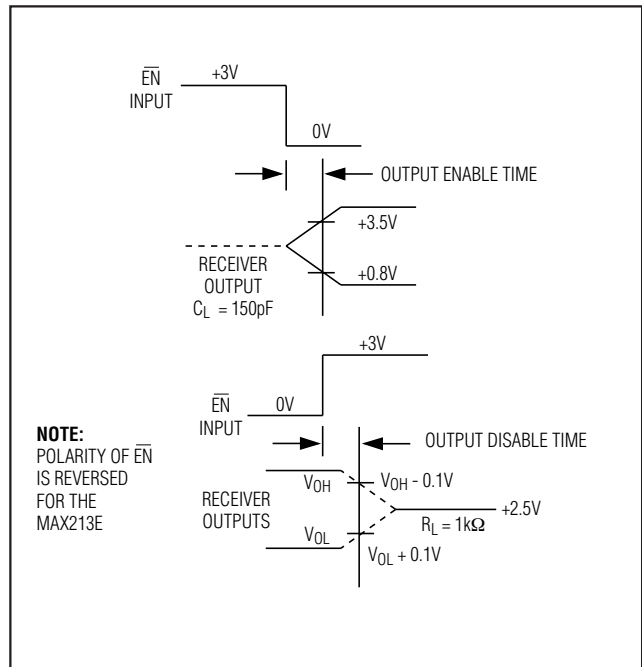

Figure 2. Receiver Output Enable and Disable Timing (MAX205E/MAX206E/MAX211E/MAX213E/MAX241E)



# ±15kV ESD-Protected, +5V RS-232 Transceivers

**MAX202E-MAX213E, MAX232E/MAX241E**

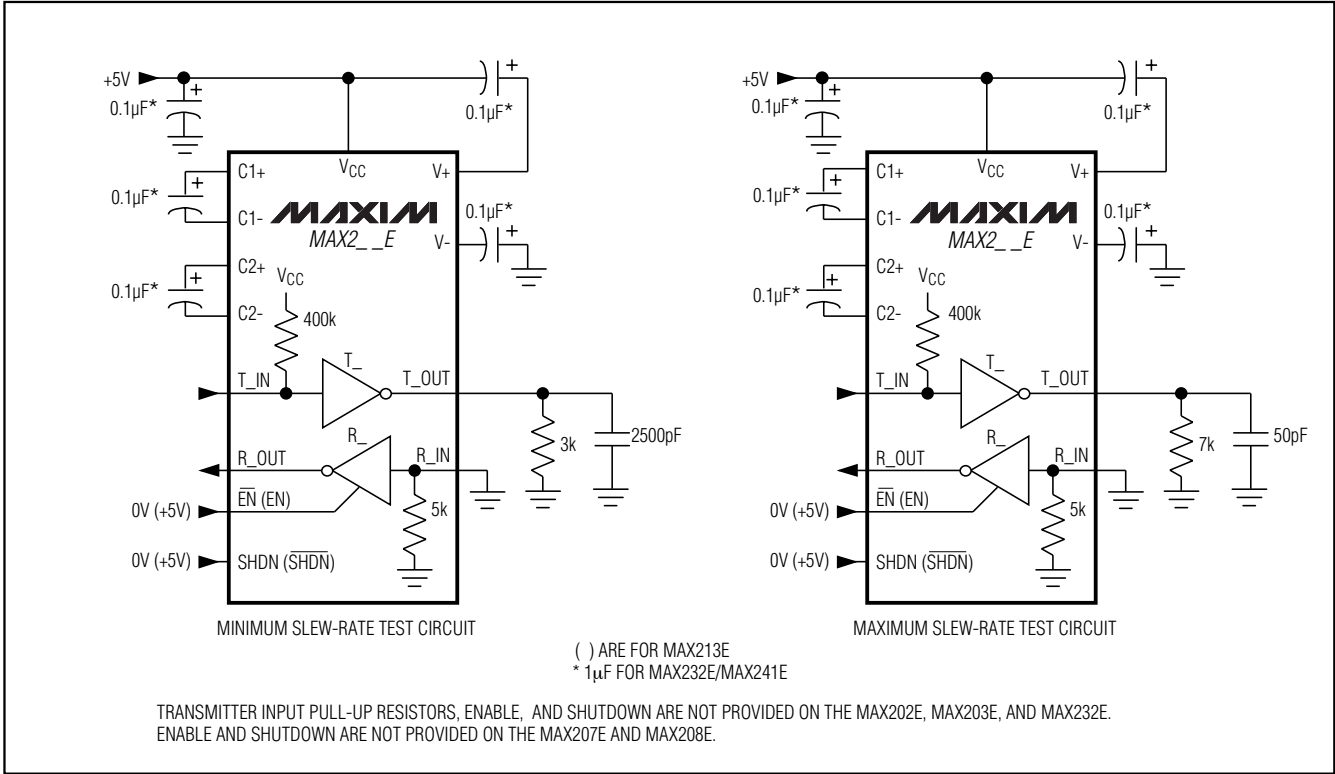

Figure 3. Transition Slew-Rate Circuit

## Detailed Description

The MAX202E-MAX213E, MAX232E/MAX241E consist of three sections: charge-pump voltage converters, drivers (transmitters), and receivers. These E versions provide extra protection against ESD. They survive ±15kV discharges to the RS-232 inputs and outputs, tested using the Human Body Model. When tested according to IEC1000-4-2, they survive ±8kV contact-discharges and ±15kV air-gap discharges. The rugged E versions are intended for use in harsh environments or applications where the RS-232 connection is frequently changed (such as notebook computers). The standard (non-"E") MAX202, MAX203, MAX205-MAX208, MAX211, MAX213, MAX232, and MAX241 are recommended for applications where cost is critical.

### +5V to ±10V Dual Charge-Pump Voltage Converter

The +5V to ±10V conversion is performed by dual charge-pump voltage converters (Figure 4). The first charge-pump converter uses capacitor C1 to double the +5V into +10V, storing the +10V on the output filter capacitor, C3. The second uses C2 to invert the +10V

into -10V, storing the -10V on the V- output filter capacitor, C4.

In shutdown mode, V+ is internally connected to VCC by a 1kΩ pull-down resistor, and V- is internally connected to ground by a 1kΩ pull up resistor.

### RS-232 Drivers

With VCC = 5V, the typical driver output voltage swing is ±8V when loaded with a nominal 5kΩ RS-232 receiver. The output swing is guaranteed to meet EIA/TIA-232E and V.28 specifications that call for ±5V minimum output levels under worst-case conditions. These include a 3kΩ load, minimum VCC, and maximum operating temperature. The open-circuit output voltage swings from (V+ - 0.6V) to V-.

Input thresholds are CMOS/TTL compatible. The unused drivers' inputs on the MAX205E-MAX208E, MAX211E, MAX213E, and MAX241E can be left unconnected because 400kΩ pull up resistors to VCC are included on-chip. Since all drivers invert, the pull up resistors force the unused drivers' outputs low. The MAX202E, MAX203E, and MAX232E do not have pull up resistors on the transmitter inputs.

# ±15kV ESD-Protected, +5V RS-232 Transceivers

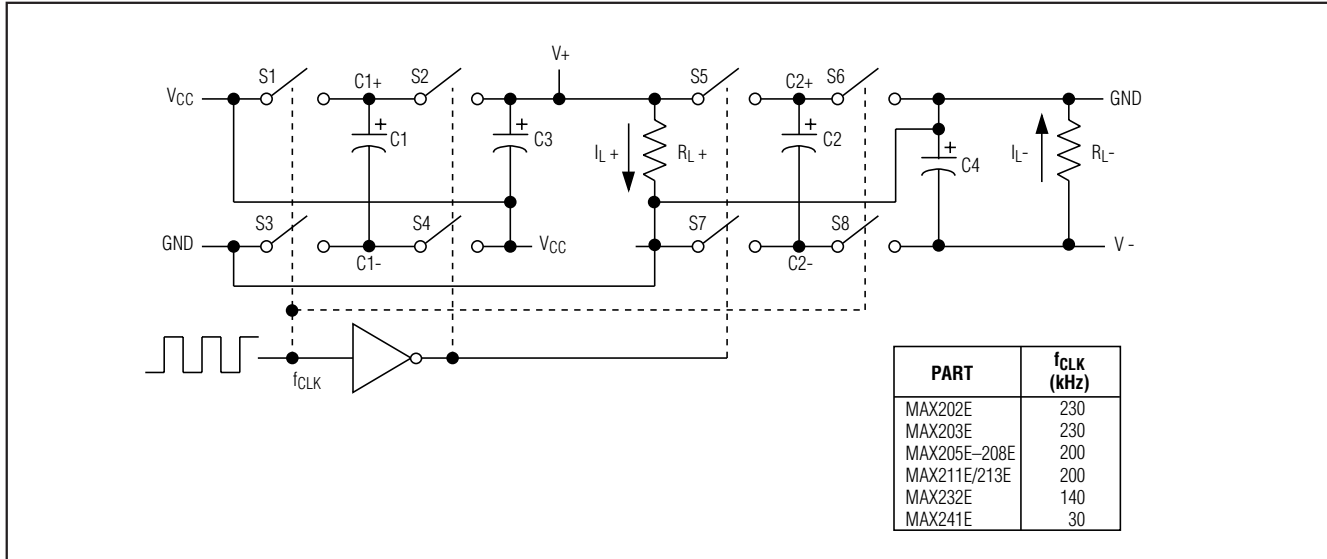

Figure 4. Charge-Pump Diagram

When in low-power shutdown mode, the MAX205E/MAX206E/MAX211E/MAX213E/MAX241E driver outputs are turned off and draw only leakage currents—even if they are back-driven with voltages between 0V and 12V. Below -0.5V in shutdown, the transmitter output is diode-clamped to ground with a 1kΩ series impedance.

### RS-232 Receivers

The receivers convert the RS-232 signals to CMOS-logic output levels. The guaranteed 0.8V and 2.4V receiver input thresholds are significantly tighter than the ±3V thresholds required by the EIA/TIA-232E specification. This allows the receiver inputs to respond to TTL/CMOS-logic levels, as well as RS-232 levels.

The guaranteed 0.8V input low threshold ensures that receivers shorted to ground have a logic 1 output. The 5kΩ input resistance to ground ensures that a receiver with its input left open will also have a logic 1 output.

Receiver inputs have approximately 0.5V hysteresis. This provides clean output transitions, even with slow rise/fall-time signals with moderate amounts of noise and ringing.

In shutdown, the MAX213E's R4 and R5 receivers have no hysteresis.

### Shutdown and Enable Control (MAX205E/MAX206E/MAX211E/MAX213E/MAX241E)

In shutdown mode, the charge pumps are turned off, V+ is pulled down to VCC, V- is pulled to ground, and the transmitter outputs are disabled. This reduces supply current typically to 1μA (15μA for the MAX213E). The time required to exit shutdown is under 1ms, as shown in Figure 5.

### Receivers

All MAX213E receivers, except R4 and R5, are put into a high-impedance state in shutdown mode (see Tables 1a and 1b). The MAX213E's R4 and R5 receivers still function in shutdown mode. These two awake-in-shutdown receivers can monitor external activity while maintaining minimal power consumption.

The enable control is used to put the receiver outputs into a high-impedance state, to allow wire-OR connection of two EIA/TIA-232E ports (or ports of different types) at the UART. It has no effect on the RS-232 drivers or the charge pumps.

**Note:** The enable control pin is active low for the MAX211E/MAX241E ( $\overline{EN}$ ), but is active high for the MAX213E (EN). The shutdown control pin is active high for the MAX205E/MAX206E/MAX211E/MAX241E (SHDN), but is active low for the MAX213E ( $\overline{SHDN}$ ).

# ±15kV ESD-Protected, +5V RS-232 Transceivers

MAX202E-MAX213E, MAX232E/MAX241E

The MAX213E's receiver propagation delay is typically 0.5µs in normal operation. In shutdown mode, propagation delay increases to 4µs for both rising and falling transitions. The MAX213E's receiver inputs have approximately 0.5V hysteresis, except in shutdown, when receivers R4 and R5 have no hysteresis.

When entering shutdown with receivers active, R4 and R5 are not valid until 80µs after SHDN is driven low. When coming out of shutdown, all receiver outputs are invalid until the charge pumps reach nominal voltage levels (less than 2ms when using 0.1µF capacitors).

### ±15kV ESD Protection

As with all Maxim devices, ESD-protection structures are incorporated on all pins to protect against electrostatic discharges encountered during handling and assembly. The driver outputs and receiver inputs have extra protection against static electricity. Maxim's engineers developed state-of-the-art structures to protect these pins against ESD of ±15kV without damage. The ESD structures withstand high ESD in all states: normal operation, shutdown, and powered down. After an ESD event, Maxim's E versions keep working without latchup, whereas competing RS-232 products can latch and must be powered down to remove latchup.

ESD protection can be tested in various ways; the transmitter outputs and receiver inputs of this product family are characterized for protection to the following limits:

- 1) ±15kV using the Human Body Model
- 2) ±8kV using the contact-discharge method specified in IEC1000-4-2
- 3) ±15kV using IEC1000-4-2's air-gap method.

### ESD Test Conditions

ESD performance depends on a variety of conditions. Contact Maxim for a reliability report that documents test set-up, test methodology, and test results.

### Human Body Model

Figure 6a shows the Human Body Model, and Figure 6b shows the current waveform it generates when discharged into a low impedance. This model consists of a 100pF capacitor charged to the ESD voltage of interest, which is then discharged into the test device through a 1.5kΩ resistor.

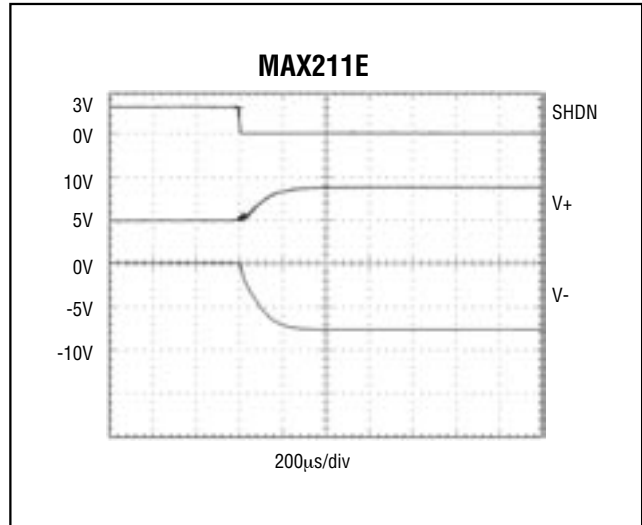

Figure 5. MAX211E V+ and V- when Exiting Shutdown (0.1µF capacitors)

**Table 1a. MAX205E/MAX206E/MAX211E/MAX241E Control Pin Configurations**

SHDN	EN	OPERATION STATUS	Tx	Rx
0	0	Normal Operation	All Active	All Active
0	1	Normal Operation	All Active	All High-Z
1	X	Shutdown	All High-Z	All High-Z

X = Don't Care

**Table 1b. MAX213E Control Pin Configurations**

SHDN	EN	OPERATION STATUS	Tx 1-4	Rx	
				1-3	4, 5
0	0	Shutdown	All High-Z	High-Z	High-Z
0	1	Shutdown	All High-Z	High-Z	Active*
1	0	Normal Operation	All Active	High-Z	High-Z
1	1	Normal Operation	All Active	Active	Active

\*Active = active with reduced performance

# ±15kV ESD-Protected, +5V RS-232 Transceivers

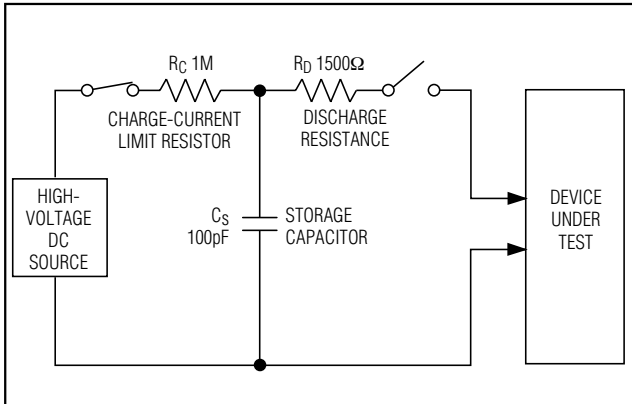

Figure 6a. Human Body ESD Test Model

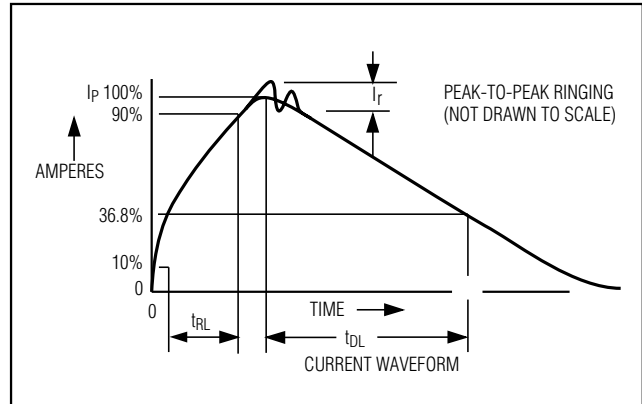

Figure 6b. Human Body Model Current Waveform

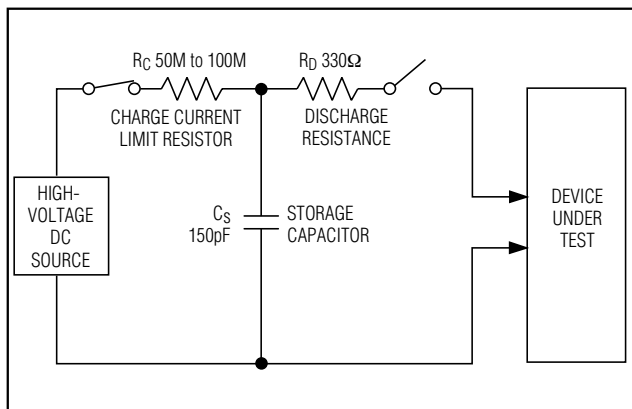

Figure 7a. IEC1000-4-2 ESD Test Model

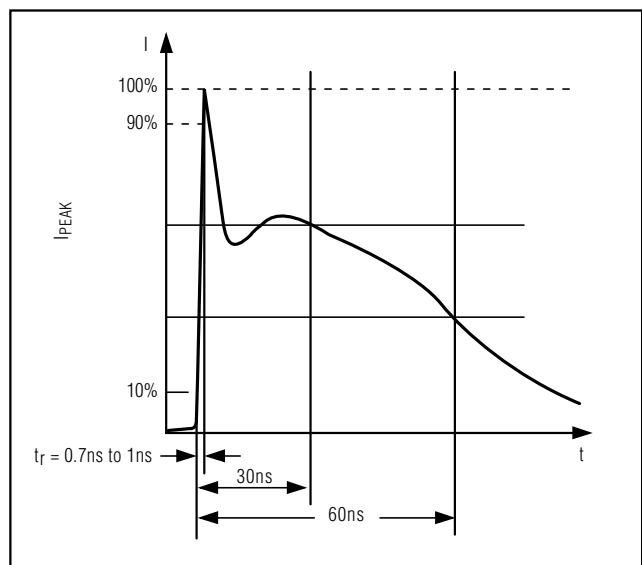

Figure 7b. IEC1000-4-2 ESD Generator Current Waveform

### IEC1000-4-2

The IEC1000-4-2 standard covers ESD testing and performance of finished equipment; it does not specifically refer to integrated circuits. The MAX202E/MAX203E-MAX213E, MAX232E/MAX241E help you design equipment that meets level 4 (the highest level) of IEC1000-4-2, without the need for additional ESD-protection components.

The major difference between tests done using the Human Body Model and IEC1000-4-2 is higher peak current in IEC1000-4-2, because series resistance is lower in the IEC1000-4-2 model. Hence, the ESD withstand voltage measured to IEC1000-4-2 is generally lower than that measured using the Human Body Model. Figure 7b shows the current waveform for the 8kV IEC1000-4-2 level-four ESD contact-discharge test.

The air-gap test involves approaching the device with a charged probe. The contact-discharge method connects the probe to the device before the probe is energized.

### Machine Model

The Machine Model for ESD tests all pins using a 200pF storage capacitor and zero discharge resistance. Its objective is to emulate the stress caused by contact that occurs with handling and assembly during manufacturing. Of course, all pins require this protection during manufacturing, not just RS-232 inputs and outputs. Therefore, after PC board assembly, the Machine Model is less relevant to I/O ports.

# ±15kV ESD-Protected, +5V RS-232 Transceivers

MAX202E-MAX213E, MAX232E/MAX241E

## Applications Information

### Capacitor Selection

The capacitor type used for C1–C4 is not critical for proper operation. The MAX202E, MAX206–MAX208E, MAX211E, and MAX213E require 0.1µF capacitors, and the MAX232E and MAX241E require 1µF capacitors, although in all cases capacitors up to 10µF can be used without harm. Ceramic, aluminum-electrolytic, or tantalum capacitors are suggested for the 1µF capacitors, and ceramic dielectrics are suggested for the 0.1µF capacitors. When using the minimum recommended capacitor values, make sure the capacitance value does not degrade excessively as the operating temperature varies. If in doubt, use capacitors with a larger (e.g., 2x) nominal value. The capacitors' effective series resistance (ESR), which usually rises at low temperatures, influences the amount of ripple on V+ and V-.

Use larger capacitors (up to 10µF) to reduce the output impedance at V+ and V-. This can be useful when "stealing" power from V+ or from V-. The MAX203E and MAX205E have internal charge-pump capacitors.

Bypass VCC to ground with at least 0.1µF. In applications sensitive to power-supply noise generated by the charge pumps, decouple VCC to ground with a capacitor the same size as (or larger than) the charge-pump capacitors (C1–C4).

### V+ and V- as Power Supplies

A small amount of power can be drawn from V+ and V-, although this will reduce both driver output swing and noise margins. Increasing the value of the charge-pump capacitors (up to 10µF) helps maintain performance when power is drawn from V+ or V-.

### Driving Multiple Receivers

Each transmitter is designed to drive a single receiver. Transmitters can be paralleled to drive multiple receivers.

### Driver Outputs when Exiting Shutdown

The driver outputs display no ringing or undesirable transients as they come out of shutdown.

### High Data Rates

These transceivers maintain the RS-232 ±5.0V minimum driver output voltages at data rates of over 120kbps. For data rates above 120kbps, refer to the Transmitter Output Voltage vs. Load Capacitance graphs in the *Typical Operating Characteristics*. Communication at these high rates is easier if the capacitive loads on the transmitters are small; i.e., short cables are best.

**Table 2. Summary of EIA/TIA-232E, V.28 Specifications**

PARAMETER		CONDITIONS	EIA/TIA-232E, V.28 SPECIFICATIONS
Driver Output Voltage	0 Level	3kΩ to 7kΩ load	+5V to +15V
	1 Level	3kΩ to 7kΩ load	-5V to -15V
Driver Output Level, Max		No load	±25V
Data Rate		3kΩ ≤ R <sub>L</sub> ≤ 7kΩ, C <sub>L</sub> ≤ 2500pF	Up to 20kbps
Receiver Input Voltage	0 Level		+3V to +15V
	1 Level		-3V to -15V
Receiver Input Level			±25V
Instantaneous Slew Rate, Max		3kΩ ≤ R <sub>L</sub> ≤ 7kΩ, C <sub>L</sub> ≤ 2500pF	30V/µs
Driver Output Short-Circuit Current, Max			100mA
Transition Rate on Driver Output		V.28	1ms or 3% of the period
		EIA/TIA-232E	4% of the period
Driver Output Resistance		-2V < V <sub>OUT</sub> < +2V	300Ω

# ±15kV ESD-Protected, +5V RS-232 Transceivers

**Table 3. DB9 Cable Connections Commonly Used for EIA/TIAE-232E and V.24 Asynchronous Interfaces**

PIN	CONNECTION	
1	Received Line Signal Detector (sometimes called Carrier Detect, DCD)	Handshake from DCE
2	Receive Data (RD)	Data from DCE
3	Transmit Data (TD)	Data from DTE
4	Data Terminal Ready	Handshake from DTE
5	Signal Ground	Reference point for signals
6	Data Set Ready (DSR)	Handshake from DCE
7	Request to Send (RTS)	Handshake from DTE
8	Clear to Send (CTS)	Handshake from DCE
9	Ring Indicator	Handshake from DCE

## Pin Configurations and Typical Operating Circuits (continued)

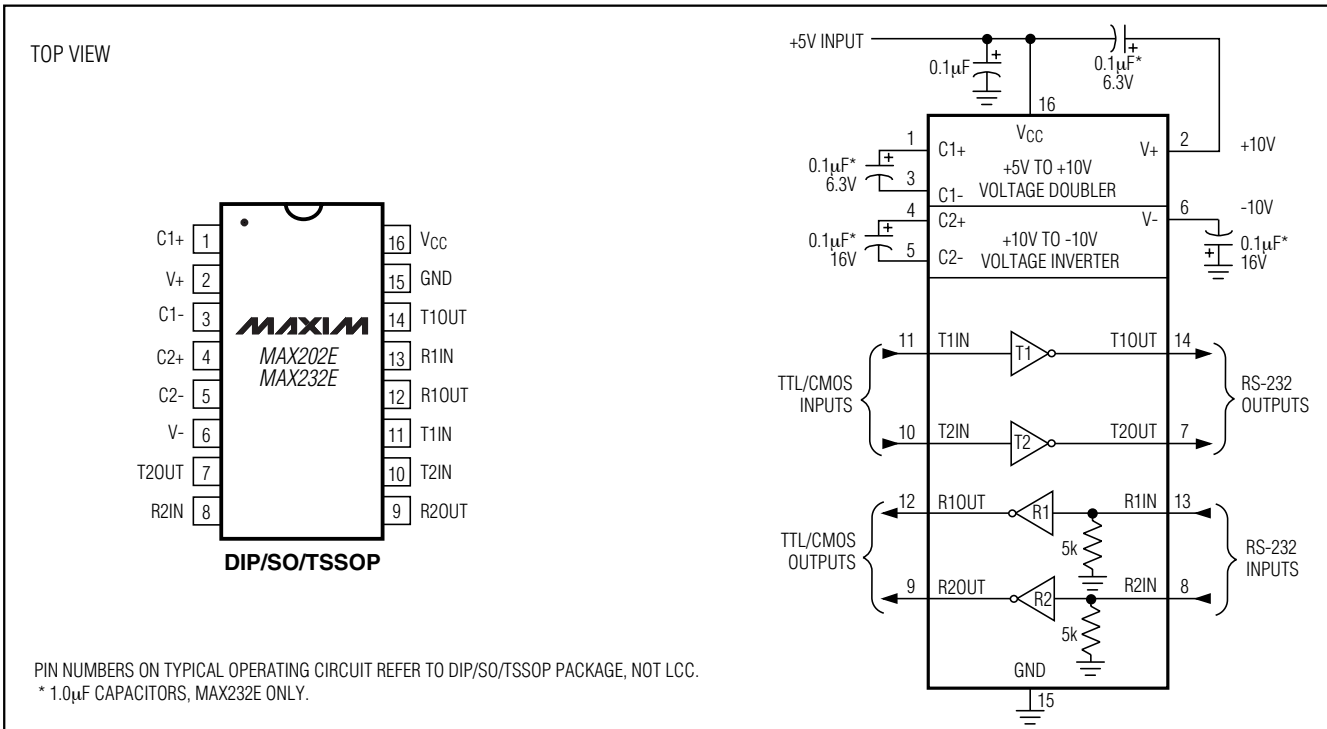

# ±15kV ESD-Protected, +5V RS-232 Transceivers

## Pin Configurations and Typical Operating Circuits (continued)

**MAX202E-MAX213E, MAX232E/MAX241E**

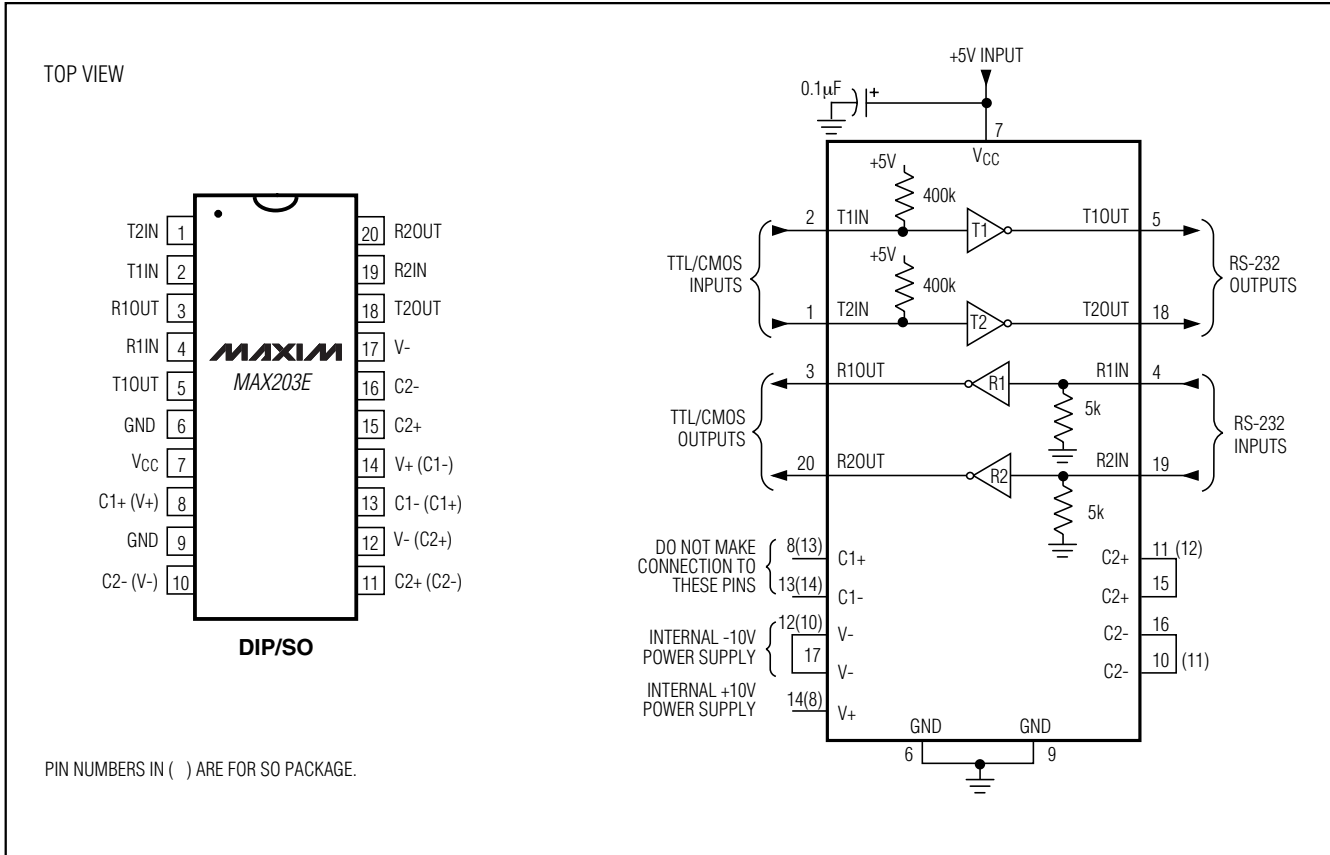

# ±15kV ESD-Protected, +5V RS-232 Transceivers

## Pin Configurations and Typical Operating Circuits (continued)

**MAX202E-MAX213E, MAX232E/MAX241E**

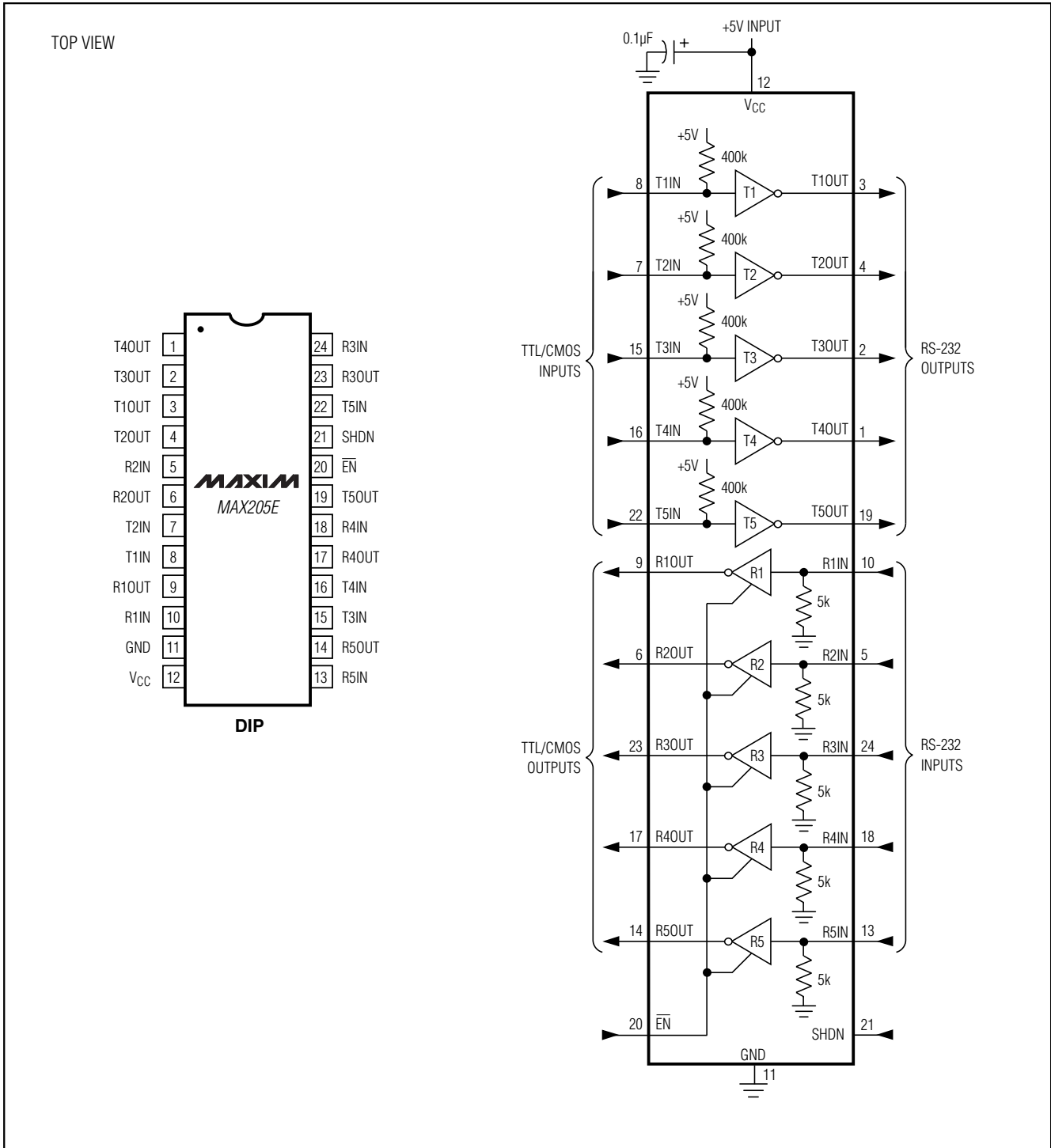



# ±15kV ESD-Protected, +5V RS-232 Transceivers

## Pin Configurations and Typical Operating Circuits (continued)

**MAX202E-MAX213E, MAX232E/MAX241E**

TOP VIEW

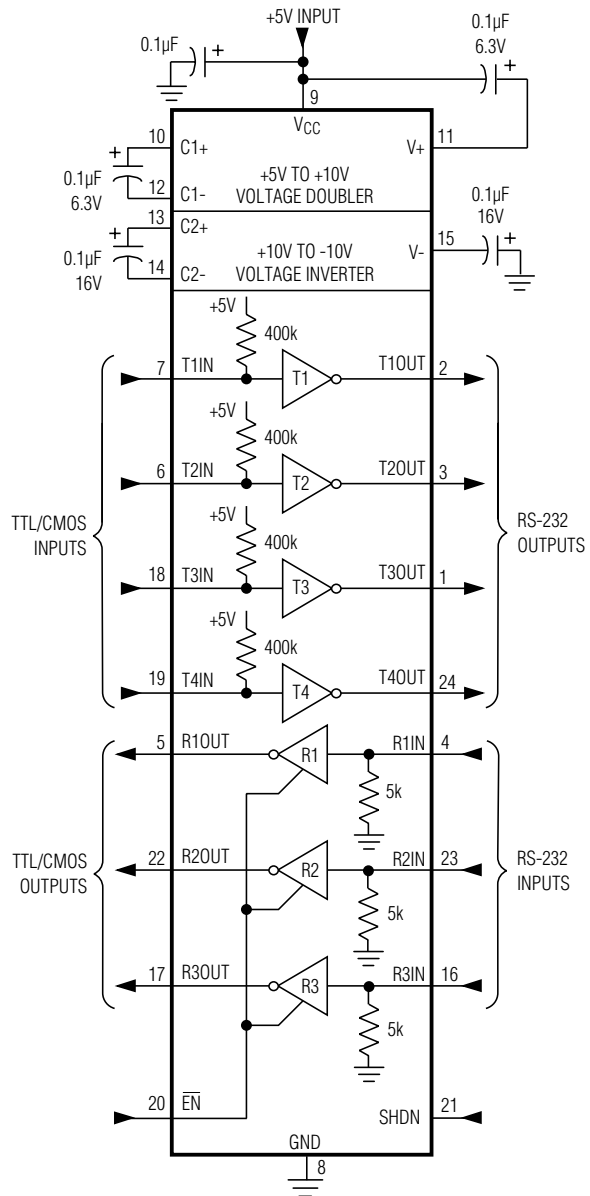
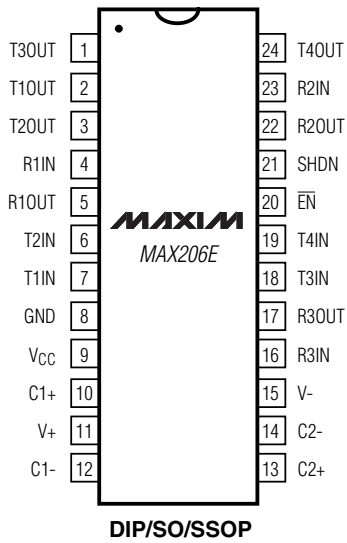

# ±15kV ESD-Protected, +5V RS-232 Transceivers

**MAX202E-MAX213E, MAX232E/MAX241E**

## Pin Configurations and Typical Operating Circuits (continued)

TOP VIEW

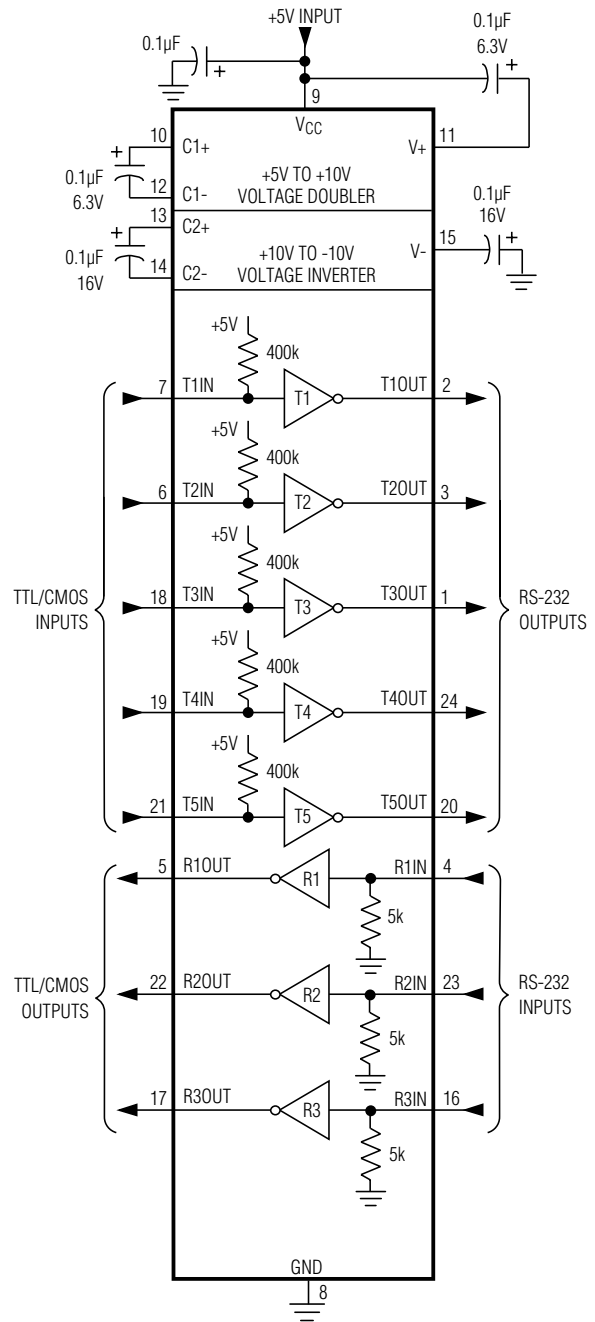
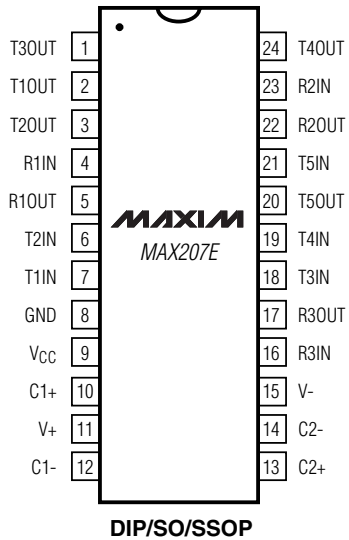

# ±15kV ESD-Protected, +5V RS-232 Transceivers

## Pin Configurations and Typical Operating Circuits (continued)

**MAX202E-MAX213E, MAX232E/MAX241E**

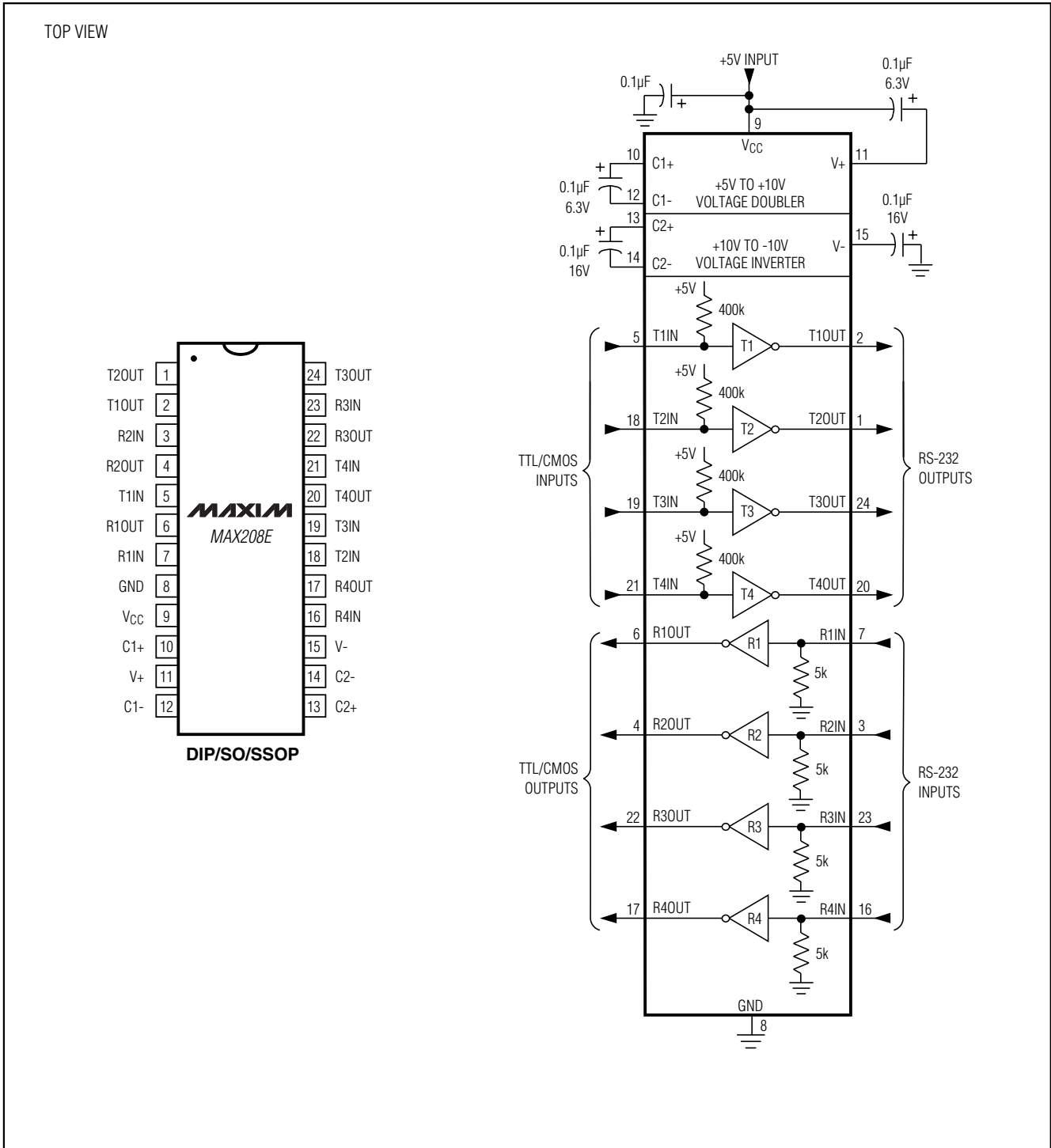

# ±15kV ESD-Protected, +5V RS-232 Transceivers

**MAX202E-MAX213E, MAX232E/MAX241E**

## Pin Configurations and Typical Operating Circuits (continued)

TOP VIEW

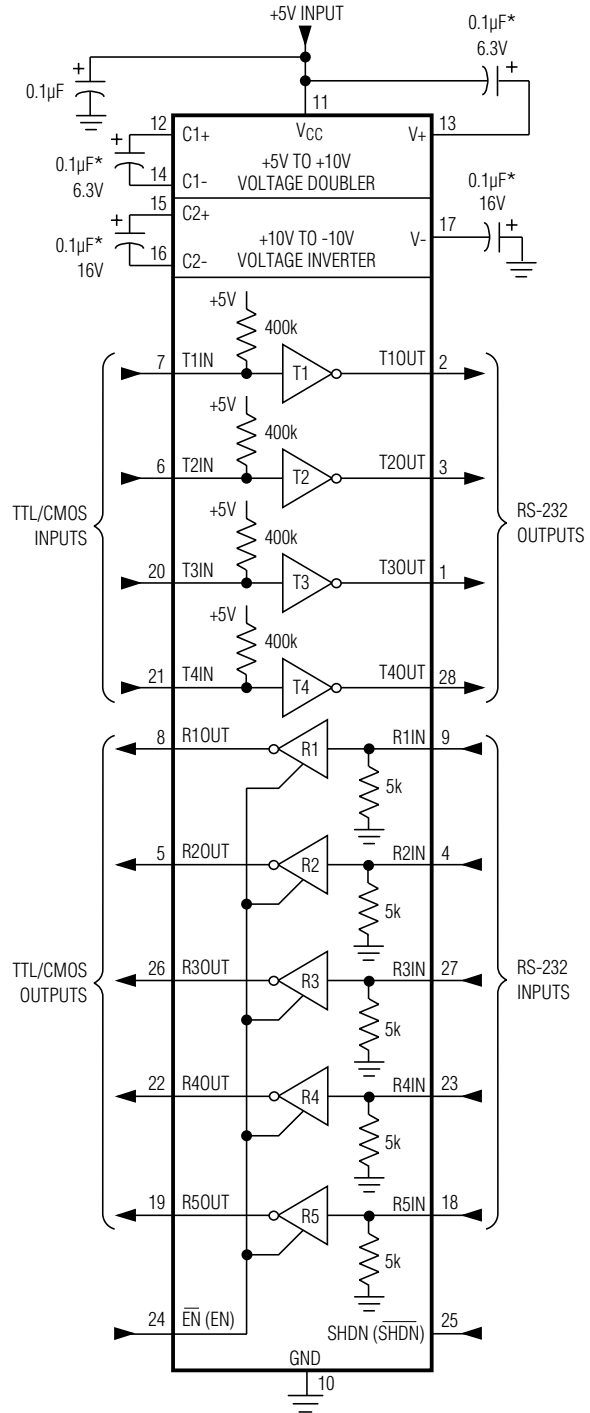
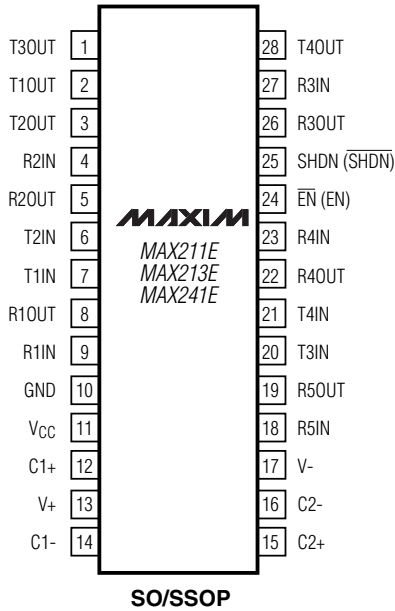

( ) ARE FOR MAX213E ONLY  
 \* 1.0µF CAPACITORS, MAX241E ONLY

# ±15kV ESD-Protected, +5V RS-232 Transceivers

## Ordering Information

PART	TEMP RANGE	PIN-PACKAGE
<b>MAX202ECPE</b>	0°C to +70°C	16 Plastic DIP
MAX202ECSE	0°C to +70°C	16 Narrow SO
MAX202ECUE	0°C to +70°C	16 TSSOP
MAX202ECWE	0°C to +70°C	16 Wide SO
MAX202EC/D	0°C to +70°C	Dice*
MAX202EEPE	-40°C to +85°C	16 Plastic DIP
MAX202EESE	-40°C to +85°C	16 Narrow SO
MAX202EEUE	-40°C to +85°C	16 TSSOP
MAX202EEWE	-40°C to +85°C	16 Wide SO
<b>MAX203ECP</b>	0°C to +70°C	20 Plastic DIP
MAX203ECWP	0°C to +70°C	20 SO
MAX203EEPP	-40°C to +85°C	20 Plastic DIP
MAX203EEWP	-40°C to +85°C	20 SO
<b>MAX205ECPG</b>	0°C to +70°C	24 Wide Plastic DIP
MAX205EEPG	-40°C to +85°C	24 Wide Plastic DIP
<b>MAX206ECNG</b>	0°C to +70°C	24 Narrow Plastic DIP
MAX206ECWG	0°C to +70°C	24 SO
MAX206ECAG	0°C to +70°C	24 SSOP
MAX206EENG	-40°C to +85°C	24 Narrow Plastic DIP
MAX206EEWG	-40°C to +85°C	24 SO
MAX206EEAG	-40°C to +85°C	24 SSOP
<b>MAX207ECNG</b>	0°C to +70°C	24 Narrow Plastic DIP
MAX207ECWG	0°C to +70°C	24 SO
MAX207ECAG	0°C to +70°C	24 SSOP
MAX207EENG	-40°C to +85°C	24 Narrow Plastic DIP
MAX207EEWG	-40°C to +85°C	24 SO
MAX207EEAG	-40°C to +85°C	24 SSOP

PART	TEMP RANGE	PIN-PACKAGE
<b>MAX208ECNG</b>	0°C to +70°C	24 Narrow Plastic DIP
MAX208ECWG	0°C to +70°C	24 SO
MAX208ECAG	0°C to +70°C	24 SSOP
MAX208EENG	-40°C to +85°C	24 Narrow Plastic DIP
MAX208EEWG	-40°C to +85°C	24 SO
MAX208EEAG	-40°C to +85°C	24 SSOP
<b>MAX211ECWI</b>	0°C to +70°C	28 SO
MAX211ECAI	0°C to +70°C	28 SSOP
MAX211EEWI	-40°C to +85°C	28 SO
MAX211EEAI	-40°C to +85°C	28 SSOP
<b>MAX213ECWI</b>	0°C to +70°C	28 SO
MAX213ECAI	0°C to +70°C	28 SSOP
MAX213EEWI	-40°C to +85°C	28 SO
MAX213EEAI	-40°C to +85°C	28 SSOP
<b>MAX232ECPE</b>	0°C to +70°C	16 Plastic DIP
MAX232ECSE	0°C to +70°C	16 Narrow SO
MAX232ECWE	0°C to +70°C	16 Wide SO
MAX232EC/D	0°C to +70°C	Dice*
MAX232EEPE	-40°C to +85°C	16 Plastic DIP
MAX232EESE	-40°C to +85°C	16 Narrow SO
MAX232EEWE	-40°C to +85°C	16 Wide SO
<b>MAX241ECWI</b>	0°C to +70°C	28 SO
MAX241ECAI	0°C to +70°C	28 SSOP
MAX241EEWI	-40°C to +85°C	28 SO
MAX241EEAI	-40°C to +85°C	28 SSOP

\*Dice are specified at  $T_A = +25^\circ\text{C}$ .

**MAX202E-MAX213E, MAX232E/MAX241E**

# ±15kV ESD-Protected, +5V RS-232 Transceivers

## Chip Topographies

**MAX202E-MAX213E, MAX232E/MAX241E**

MAX202E/MAX232E

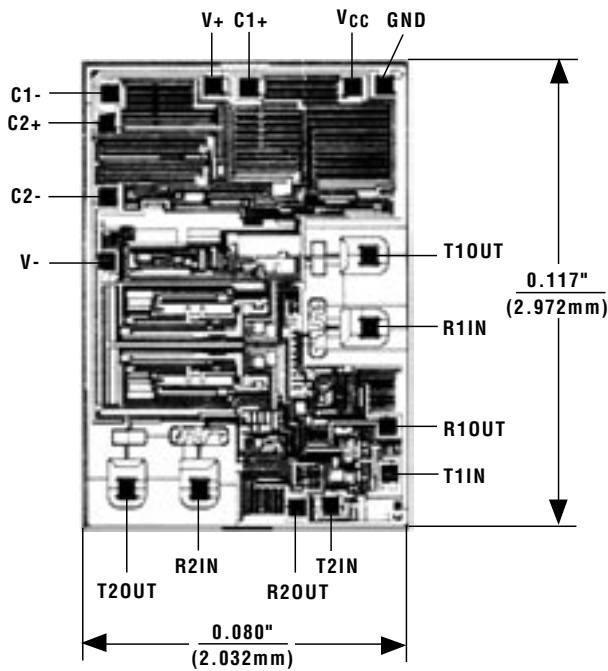

MAX211E/MAX213E/MAX241E

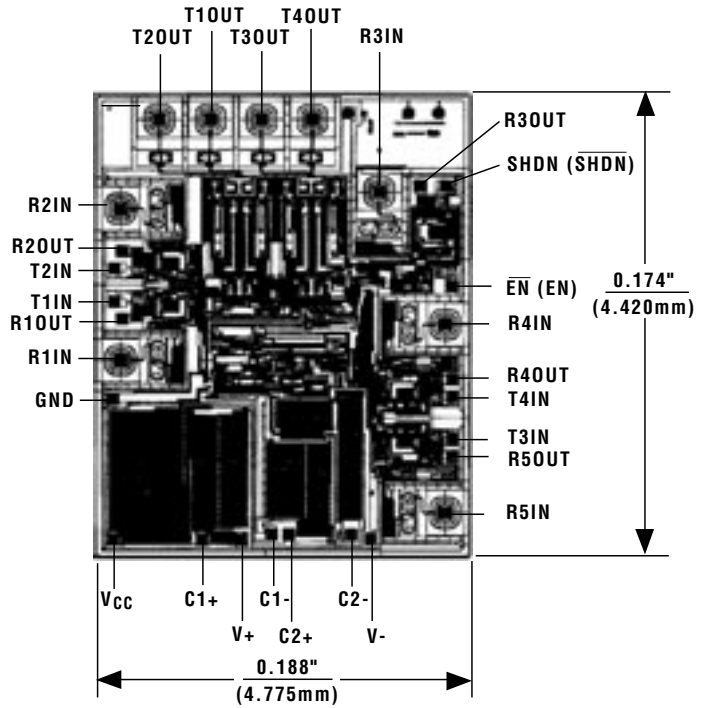

( ) ARE FOR MAX213E ONLY

TRANSISTOR COUNT: 123  
SUBSTRATE CONNECTED TO GND

TRANSISTOR COUNT: 542  
SUBSTRATE CONNECTED TO GND

## Chip Information

### MAX205E/MAX206E/MAX207E/MAX208E

TRANSISTOR COUNT: 328  
SUBSTRATE CONNECTED TO GND

# ±15kV ESD-Protected, +5V RS-232 Transceivers

## Package Information

(The package drawing(s) in this data sheet may not reflect the most current specifications. For the latest package outline information, go to [www.maxim-ic.com/packages](http://www.maxim-ic.com/packages).)

MAX202E-MAX213E, MAX232E/MAX241E

PDIPN.EPS

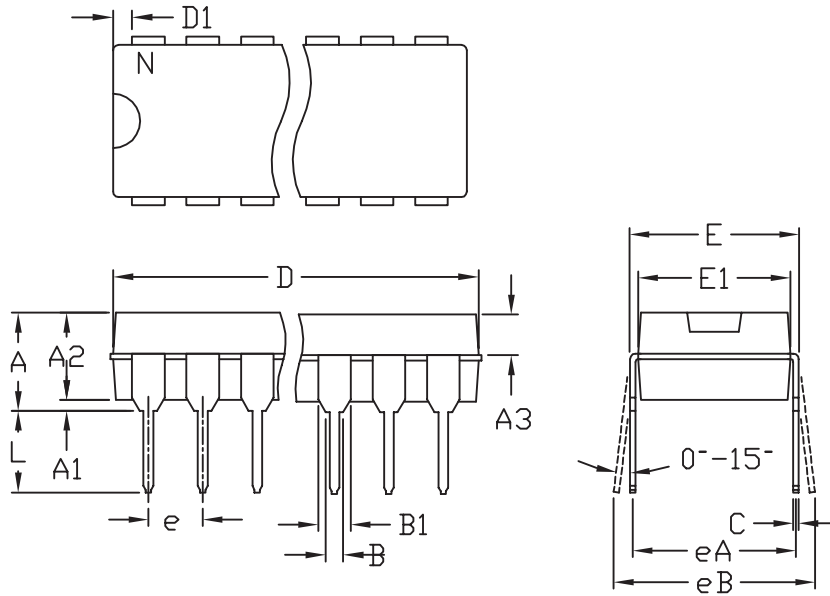

	INCHES		MILLIMETERS	
	MIN	MAX	MIN	MAX
A	---	0.180	---	4.572
A1	0.015	---	0.38	---
A2	0.125	0.175	3.18	4.45
A3	0.055	0.080	1.40	2.03
B	0.015	0.022	0.381	0.56
B1	0.045	0.065	1.14	1.65
C	0.008	0.014	0.2	0.355
D1	0.005	0.080	0.13	2.03
E	0.300	0.325	7.62	8.26
E1	0.240	0.310	6.10	7.87
e	0.100 BSC.		2.54 BSC.	
eA	0.300 BSC.		7.62 BSC.	
eB	0.400 BSC.		10.16 BSC.	
L	0.115	0.150	2.921	3.81

	INCHES		MILLIMETERS		N	MS001
	MIN	MAX	MIN	MAX		
D	0.348	0.390	8.84	9.91	8	AB
D	0.735	0.765	18.67	19.43	14	AC
D	0.745	0.765	18.92	19.43	16	AA
D	0.885	0.915	22.48	23.24	18	AD
D	1.015	1.045	25.78	26.54	20	AE
D	1.14	1.265	28.96	32.13	24	AF
D	1.360	1.380	34.54	35.05	28	*5

- NOTES:
1. D&E DO NOT INCLUDE MOLD FLASH
  2. MOLD FLASH OR PROTRUSIONS NOT TO EXCEED .15mm (.006")
  3. CONTROLLING DIMENSION: MILLIMETER
  4. MEETS JEDEC MS001-XX AS SHOWN IN ABOVE TABLE
  5. SIMILAR TO JEDEC MO-058AB
  6. N = NUMBER OF PINS

 <small>230 SAN GABRIEL DR. SUNNYVALE CA 94085 FAX (408) 737 7794</small> <small>PROPRIETARY INFORMATION</small>	PACKAGE FAMILY OUTLINE: PDIP .300"	1/1	21-0043 D
	TITLE		DOCUMENT CONTROL NUMBER REV

# ±15kV ESD-Protected, +5V RS-232 Transceivers

## Package Information (continued)

(The package drawing(s) in this data sheet may not reflect the most current specifications. For the latest package outline information, go to [www.maxim-ic.com/packages](http://www.maxim-ic.com/packages).)

DIM	INCHES		MILLIMETERS	
	MIN	MAX	MIN	MAX
A	0.068	0.078	1.73	1.99
A1	0.002	0.008	0.05	0.21
B	0.010	0.015	0.25	0.38
C	0.004	0.008	0.09	0.20
D	SEE VARIATIONS			
E	0.205	0.212	5.20	5.38
e	0.0256 BSC		0.65 BSC	
H	0.301	0.311	7.65	7.90
L	0.025	0.037	0.63	0.95
$\alpha$	0 $^{\circ}$	8 $^{\circ}$	0 $^{\circ}$	8 $^{\circ}$

D	INCHES		MILLIMETERS		N
	MIN	MAX	MIN	MAX	
D	0.239	0.249	6.07	6.33	14L
D	0.239	0.249	6.07	6.33	16L
D	0.278	0.289	7.07	7.33	20L
D	0.317	0.328	8.07	8.33	24L
D	0.397	0.407	10.07	10.33	28L

NOTES:

- D&E DO NOT INCLUDE MOLD FLASH.
- MOLD FLASH OR PROTRUSIONS NOT TO EXCEED .15 MM (.006").
- CONTROLLING DIMENSION: MILLIMETERS.
- MEETS JEDEC MO150.
- LEADS TO BE COPLANAR WITHIN 0.10 MM.

**DALLAS SEMICONDUCTOR** **MAXIM**

PROPRIETARY INFORMATION

TITLE:  
PACKAGE OUTLINE, SSOP, 5.3 MM

APPROVAL	DOCUMENT CONTROL NO. 21-0056	REV. C	1/1
----------	---------------------------------	-----------	-----

SSOP-EPS



# ±15kV ESD-Protected, +5V RS-232 Transceivers

## Package Information (continued)

(The package drawing(s) in this data sheet may not reflect the most current specifications. For the latest package outline information, go to [www.maxim-ic.com/packages](http://www.maxim-ic.com/packages).)

MAX202E-MAX213E, MAX232E/MAX241E

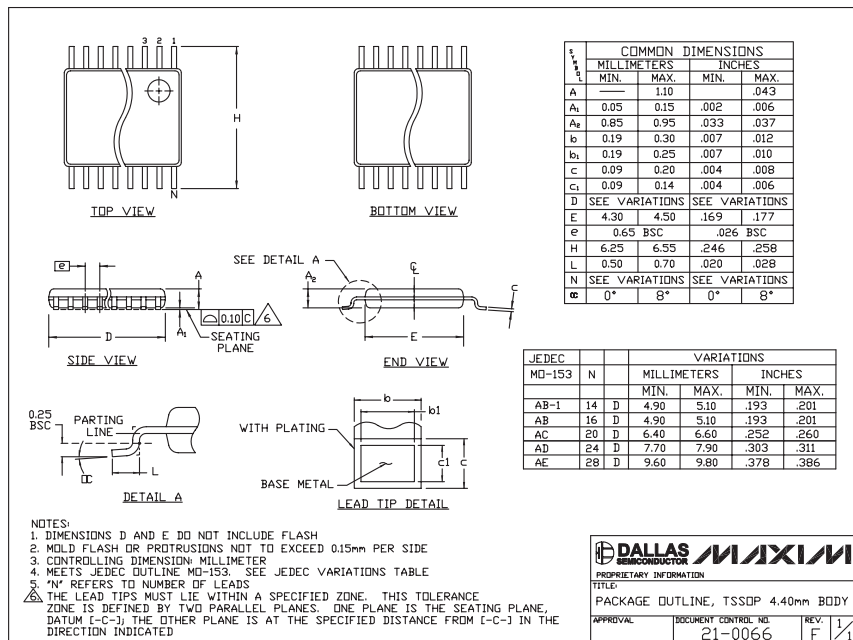
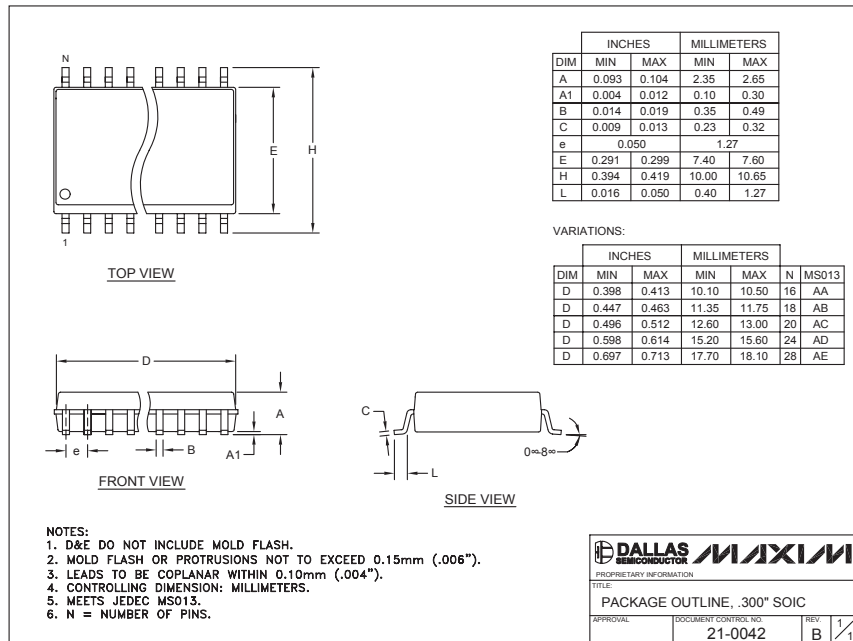

Maxim cannot assume responsibility for use of any circuitry other than circuitry entirely embodied in a Maxim product. No circuit patent licenses are implied. Maxim reserves the right to change the circuitry and specifications without notice at any time.

Maxim Integrated Products, 120 San Gabriel Drive, Sunnyvale, CA 94086 (408) 737-7600 25