



ST207E

± 15KV ESD PROTECTED 5V RS-232 TRANSCEIVER

PRELIMINARY DATA

- ESD PROTECTION FOR RS-232 I/O PINS:
± 15 KV HUMAN BODY MODEL
- GUARANTEED 120kbps DATA RATE -
LapLink™ COMPATIBLE
- GUARANTEED SLEW RATE 3V/μs (Min)
- OPERATE FROM A SINGLE 5V POWER
SUPPLY
- PACKAGED IN SO-24, SSO-24 AND TSSOP24
PACKAGES

DESCRIPTION

The ST207E is a 5 driver and 3 receiver devices designed for RS-232 and V.28 communications in harsh environments. Each transmitter output and receiver input is protected against ±15KV electrostatic discharge (ESD) shocks. The drivers and receivers of the ST207E meet all EIA/TIA-232E and CCITT V.28 specifications at data rates up to 120Kbps, when loaded in accordance with the EIA/TIA-232E specification.

The ST207E operates with four 0.1μF capacitors. It comes in 24-pin SO and TSSOP packages.

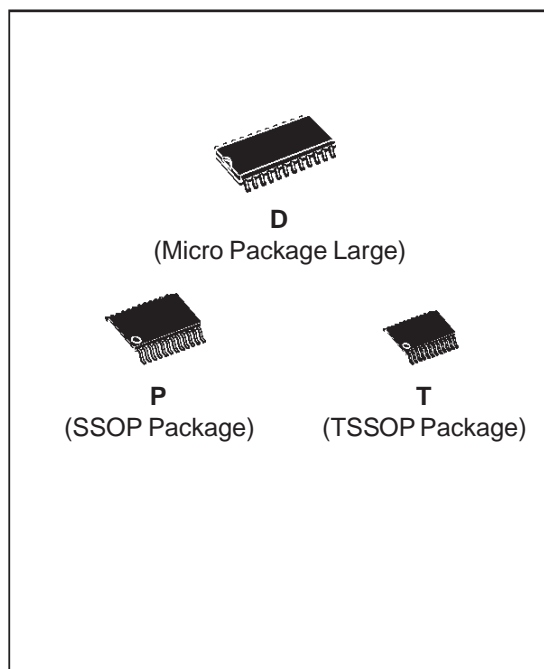

ORDER CODES

Type	Temperature Range	Package	Comments
ST207ECD	0 to 70 °C	SO-24 (Tube)	33 parts per tube / 25 tube per box
ST207EBD	-40 to 85 °C	SO-24 (Tube)	33 parts per tube / 25 tube per box
ST207ECDR	0 to 70 °C	SO-24 (Tape & Reel)	1000 parts per reel
ST207EBDR	-40 to 85 °C	SO-24 (Tape & Reel)	1000 parts per reel
ST207ECTR	0 to 70 °C	TSSOP24 (Tape & Reel)	2500 parts per reel
ST207EBTR	-40 to 85 °C	TSSOP24 (Tape & Reel)	2500 parts per reel
ST207ECPR	0 to 70 °C	SSOP24 (Tape & Reel)	
ST207EBPR	-40 to 85 °C	SSOP24 (Tape & Reel)	

PIN CONFIGURATION

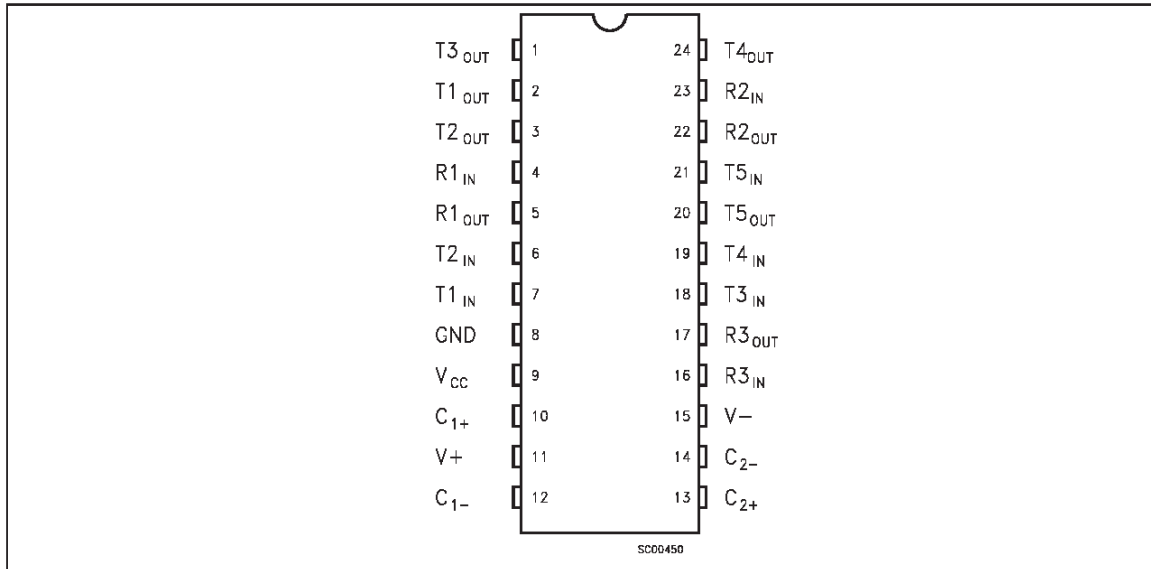

PIN DESCRIPTION

PIN No	SYMBOL	NAME AND FUNCTION
1	T3 _{OUT}	RS-232 Driver Output
2	T1 _{OUT}	RS-232 Driver Output
3	T2 _{OUT}	RS-232 Driver Output
4	R1 _{IN}	RS-232 Receiver Input
5	R1 _{OUT}	TTL/CMOS Receiver Outputs. All The Receivers Are Inactive In Shutdown
6	T2 _{IN}	TTL/CMOS Driver Inputs. Internal Pull-up to V _{CC}
7	T1 _{IN}	TTL/CMOS Driver Inputs. Internal Pull-up to V _{CC}
8	GND	Ground
9	V _{CC}	4.75V to 5.25V Supply Voltage
10	C1 ₊	Terminal For Positive Charge-pump Capacitor
11	V ₊	2V _{CC} Generated By The Charge Pump
12	C1 ₋	Terminal For Positive Charge-pump Capacitor
13	C2 ₊	Terminal For Negative Charge-pump Capacitor
14	C2 ₊	Terminal For Negative Charge-pump Capacitor
15	V ₋	-2V _{CC} Generated By The Charge Pump
16	R3 _{IN}	RS-232 Receiver Input
17	R3 _{OUT}	TTL/CMOS Receiver Outputs. All The Receivers Are Inactive In Shutdown
18	T3 _{IN}	TTL/CMOS Driver Inputs. Internal Pull-up to V _{CC}
19	T4 _{IN}	TTL/CMOS Driver Inputs. Internal Pull-up to V _{CC}
20	T5 _{OUT}	RS-232 Driver Output
21	T5 _{IN}	TTL/CMOS Driver Inputs. Internal Pull-up to V _{CC}
22	R2 _{OUT}	TTL/CMOS Receiver Outputs. All The Receivers Are Inactive In Shutdown
23	R2 _{IN}	RS-232 Receiver Input

ABSOLUTE MAXIMUM RATINGS (Note 1)

Symbol	Parameter	Value	Unit
V _{CC}	Supply Voltage	-0.3 to 6	V
V ₊	Extra Positive Voltage	(V _{CC} - 0.3) to 14	V
V ₋	Extra Negative Voltage	-14 to 0.3	V
T _{IN}	Transmitter Input Voltage Range	-0.3 to (V _{CC} + 0.3)	V
R _{IN}	Receiver Input Voltage Range	±30	V
T _{OUT}	Transmitter Output Voltage Range	(V ₋ - 0.3) to (V ₊ + 0.3)	V
R _{OUT}	Receiver Output Voltage Range	-0.3 to (V _{CC} + 0.3)	V
T _{SCTOUT}	Short Circuit Duration on T _{OUT}	Continuous	
T _{stg}	Storage Temperature Range	-65 to +150	°C

Absolute Maximum Ratings are those values beyond which damage to the device may occur. Functional operation under these condition is not implied.

ESD PERFORMANCE: TRANSMITTER OUTPUTS, RECEIVER INPUTS

Symbol	Parameter	Test Conditions	Value			Unit
			Min.	Typ.	Max.	
ESD	ESD Protection Voltage	Human Body Model		±15		kV

ELECTRICAL CHARACTERISTICS (C₁ -C₄ = 0.1μF, V_{CC} = 5V ± 5% T_A = Min to Max, unless otherwise specified. Typical Valus are referred to T_A = 25 °C)

Symbol	Parameter	Test Conditions	Value			Unit
			Min.	Typ.	Max.	
I _{SUPPLY}	V _{CC} Power Supply Current	No Load, T _A = 25 °C		2	5	mA

RECEIVER ELECTRICAL CHARACTERISTICS (C₁ -C₄ = 0.1μF, V_{CC} = 5V ± 5% T_A = Min to Max, unless otherwise specified. Typical Valus are referred to T_A = 25 °C)

Symbol	Parameter	Test Conditions	Value			Unit
			Min.	Typ.	Max.	
V _{RIN}	Receiver Input Voltage Operating Range		-30		30	V
V _{RIL}	Input Threshold Low	T _A = 25 °C, V _{CC} = 5 V	0.8	1.2		V
V _{RIH}	Input Threshold High	T _A = 25 °C, V _{CC} = 5 V		1.7	2.4	V
V _{RIHYS}	Input Hysteresis	V _{CC} = 5 V, no hysteresis in shutdown	0.2	0.5	1	V
R _{RIN}	Input Resistance	T _A = 25 °C, V _{CC} = 5 V	3	5	7	KΩ
V _{OL}	Output Voltage Low				0.4	V
V _{OH}	Output Voltage High	I _{OUT} = -1mA	3.5	V _{CC} -0.4		V

TRANSMITTER ELECTRICAL CHARACTERISTICS ($C_1 - C_4 = 0.1\mu\text{F}$, $V_{CC} = 5\text{V} \pm 5\%$ $T_A = \text{Min to Max}$, unless otherwise specified. Typical Values are referred to $T_A = 25^\circ\text{C}$)

Symbol	Parameter	Test Conditions	Value			Unit
			Min.	Typ.	Max.	
V_{TOUT}	Output Voltage Swing	All drivers loaded with $3\text{K}\Omega$ to GND	± 5	± 8.5		V
R_{OUT}	Transmitter Output Resistance	$V_{CC} = V_+ = V_- = 0\text{V}$ $V_{\text{OUT}} = \pm 2\text{V}$	300			Ω
I_{SC}	Transmitter Output Short Circuit Current			± 18	± 60	mA
I_{IL}	Input Pull-Up Current	$T_{\text{IN}} = 0\text{V}$		15	200	μA
V_{TIL}	Input Logic Threshold Low				0.8	V
V_{TIH}	Input Logic Threshold High		2			V

TIMING CHARACTERISTICS ($C_1 - C_4 = 0.1\mu\text{F}$, $V_{CC} = 5\text{V} \pm 5\%$ $T_A = \text{Min to Max}$, unless otherwise specified. Typical Values are referred to $T_A = 25^\circ\text{C}$)

Symbol	Parameter	Test Conditions	Value			Unit
			Min.	Typ.	Max.	
DR	Maximum Data Rate	$R_L = 3\text{K}\Omega$ to $7\text{K}\Omega$, $C_L = 50\text{pF}$ to 1000pF one transmitter switching	120			kbps
t_{PLHR} t_{PHLR}	Receiver Propagation Delay	All drivers loaded with $3\text{K}\Omega$ to GND		0.2	10	μs
t_{PLHT} t_{PHLT}	Transmitter Propagation Delay	$R_L = 3\text{K}\Omega$, $C_L = 2500\text{pF}$ all transmitters loaded		2		μs
SR	Transition-Region Slew Rate	$T_A = 25^\circ\text{C}$ $V_{CC} = 5\text{V}$ $R_L = 3\text{K}\Omega$ to $7\text{K}\Omega$, $C_L = 50\text{pF}$ to 1000pF measure from -3V to 3V or 3V to -3V	3	7	30	$\text{V}/\mu\text{s}$

APPLICATION CIRCUITS (note 1, note 2)

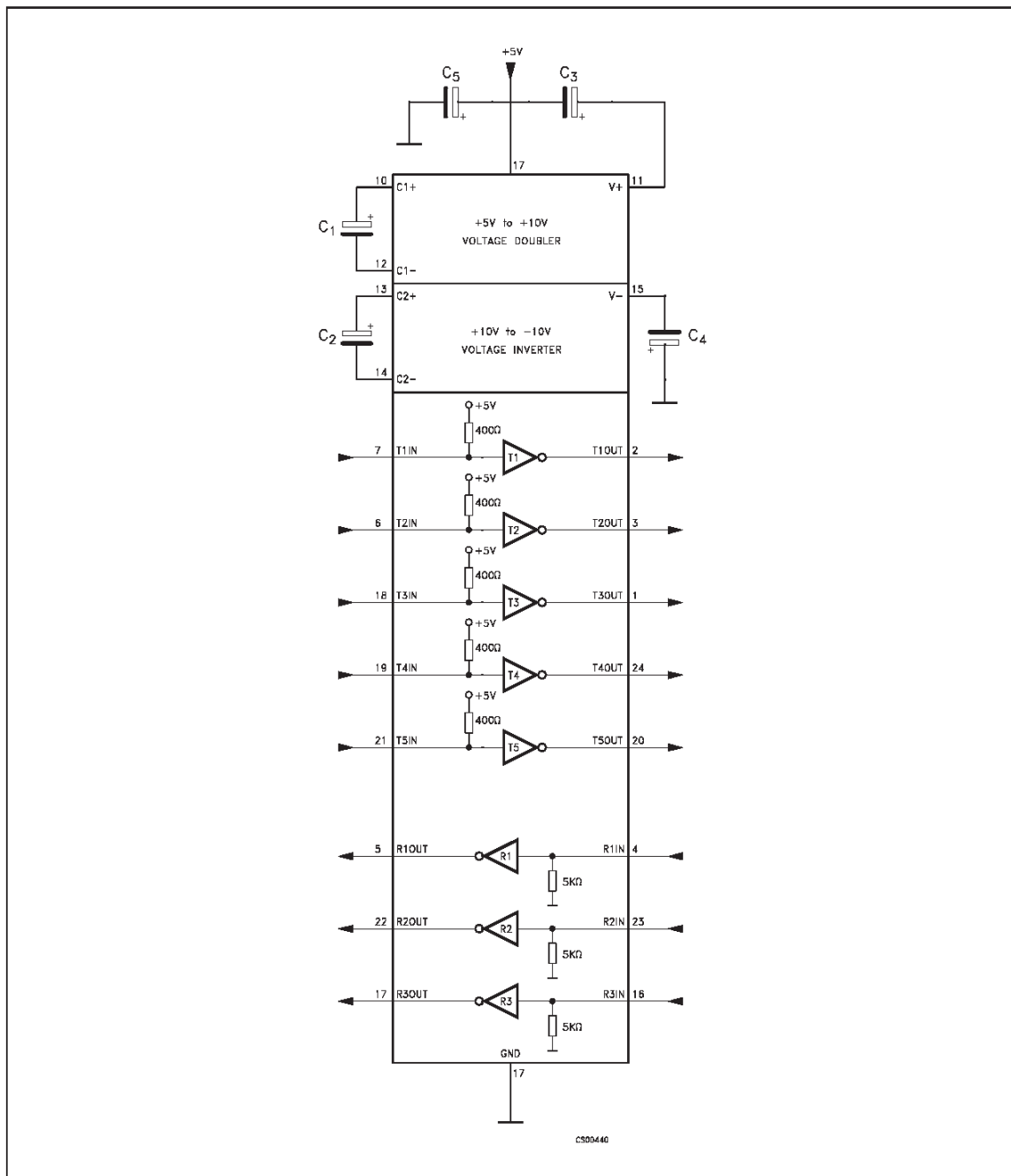

Note 1: C₁₋₄ capacitors can even be 1 μ F ones.

Note 2: C₁₋₄ can be common or biased capacitors.

Capacitance Value (μ F)

DEVICES	C1	C2	C3	C4	C5
ST207E	0.1	0.1	0.1	0.1	0.1

SO-24 MECHANICAL DATA

DIM.	mm			inch		
	MIN.	TYP.	MAX.	MIN.	TYP.	MAX.
A			2.65			0.104
a1	0.10		0.20	0.004		0.007
a2			2.45			0.096
b	0.35		0.49	0.013		0.019
b1	0.23		0.32	0.009		0.012
C		0.50			0.020	
c1	45 (typ.)					
D	15.20		15.60	0.598		0.614
E	10.00		10.65	0.393		0.420
e		1.27			0.05	
e3		13.97			0.55	
F	7.40		7.60	0.291		0.299
L	0.50		1.27	0.19		0.050
S	8 (max.)					

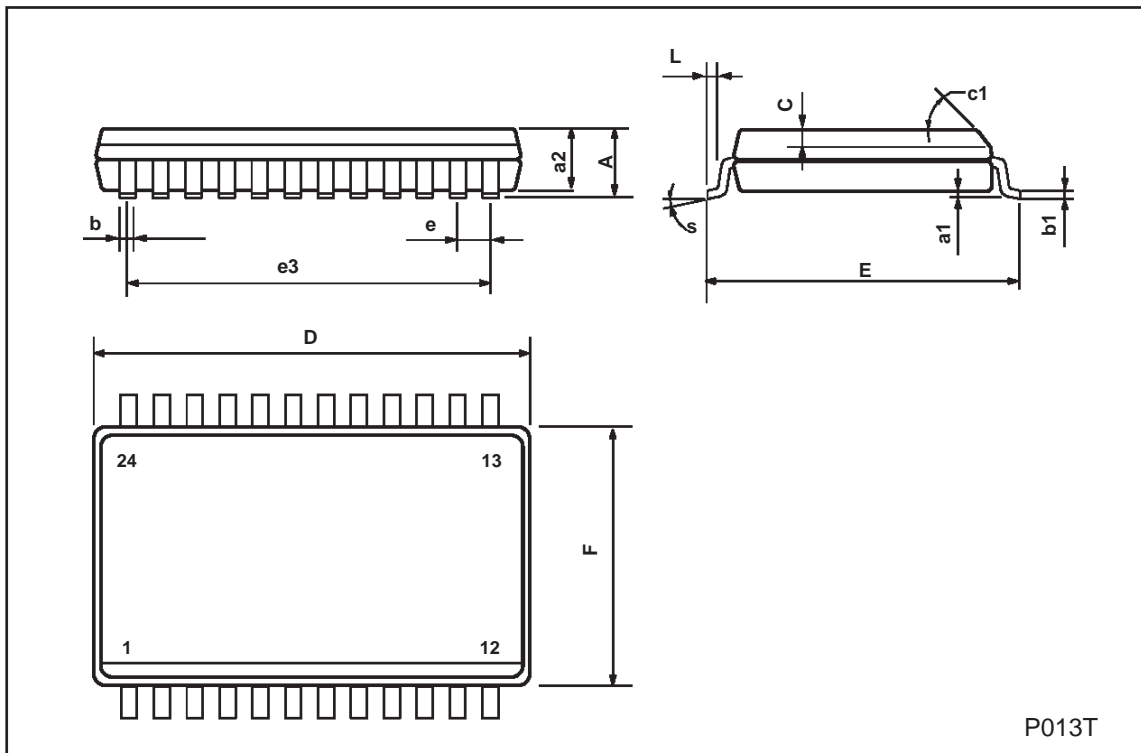

SSOP24 MECHANICAL DATA

DIM.	mm			inch		
	MIN.	TYP.	MAX.	MIN.	TYP.	MAX.
A			2.00			0.079
A1			0.25			0.010
A2	1.51		2.00	0.059		0.079
b	0.25	0.30	0.35	0.010	0.012	0.014
c	0.10		0.35	0.004		0.014
D	8.35		9.35	0.329		0.368
E	7.6		8.7	0.299		0.343
E1	5.02	6.10	6.22	0.198	0.240	0.245
e		0.65 BSC			0.0256 BSC	
K	0°		10°	0°		10°
L	0.25	0.50	0.80	0.010	0.020	0.031

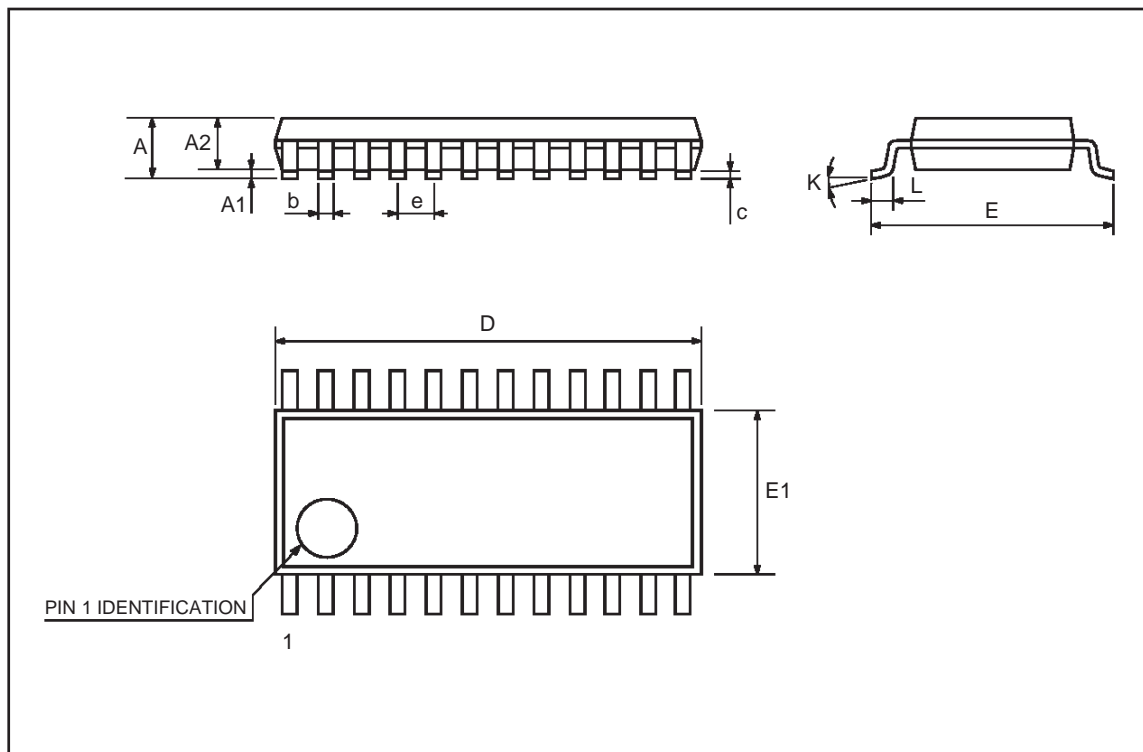

TSSOP24 MECHANICAL DATA

DIM.	mm			inch		
	MIN.	TYP.	MAX.	MIN.	TYP.	MAX.
A			1.1			0.433
A1	0.05	0.10	0.15	0.002	0.004	0.006
A2	0.85	0.9	0.95	0.335	0.354	0.374
b	0.19		0.30	0.0075		0.0118
c	0.09		0.2	0.0035		0.0079
D	7.7	7.8	7.9	0.303	0.307	0.311
E	6.25	6.4	6.5	0.246	0.252	0.256
E1	4.3	4.4	4.48	0.169	0.173	0.176
e		0.65 BSC			0.0256 BSC	
K	0°	4°	8°	0°	4°	8°
L	0.50	0.60	0.70	0.020	0.024	0.028

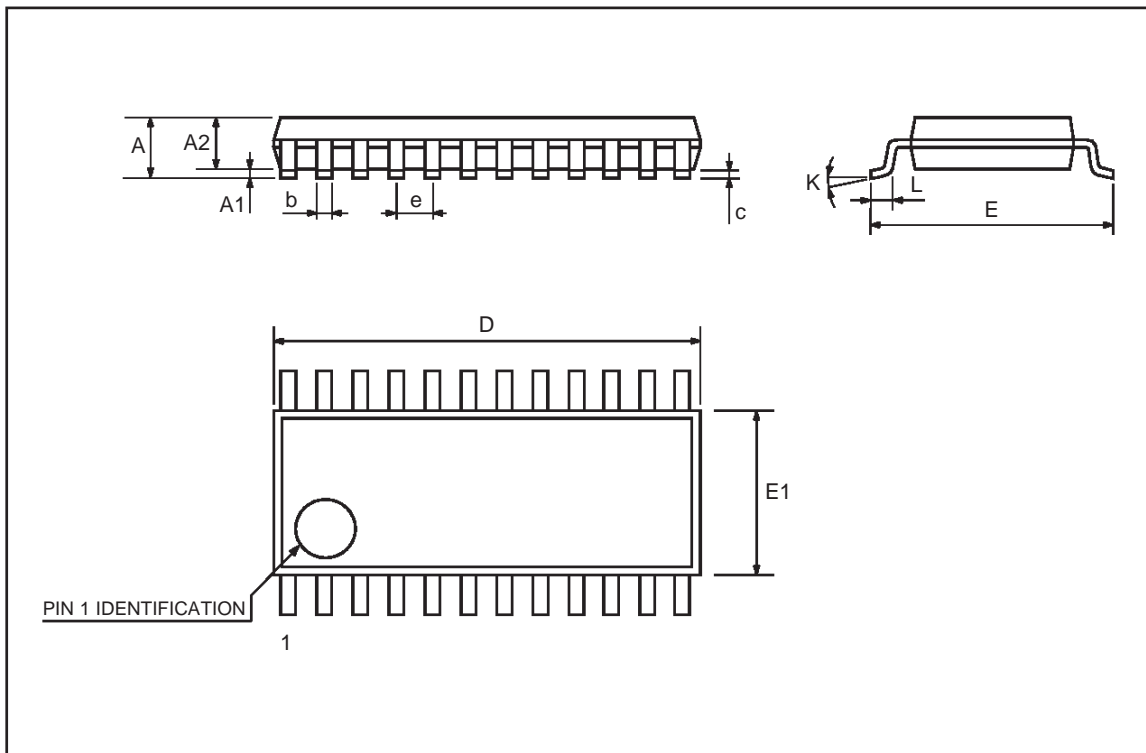

Information furnished is believed to be accurate and reliable. However, STMicroelectronics assumes no responsibility for the consequences of use of such information nor for any infringement of patents or other rights of third parties which may result from its use. No license is granted by implication or otherwise under any patent or patent rights of STMicroelectronics. Specification mentioned in this publication are subject to change without notice. This publication supersedes and replaces all information previously supplied. STMicroelectronics products are not authorized for use as critical components in life support devices or systems without express written approval of STMicroelectronics.

The ST logo is a registered trademark of STMicroelectronics

© 2000 STMicroelectronics – Printed in Italy – All Rights Reserved

STMicroelectronics GROUP OF COMPANIES

Australia - Brazil - China - Finland - France - Germany - Hong Kong - India - Italy - Japan - Malaysia - Malta - Morocco
Singapore - Spain - Sweden - Switzerland - United Kingdom - U.S.A.

<http://www.st.com>

