



MC34119

LINEAR INTEGRATED CIRCUIT

LOW POWER AUDIO AMPLIFIER

DESCRIPTION

The UTC MC34119 is a low power audio amplifier IC intended for the telephone applications, such as in speakerphones. It provides differential speaker outputs to maximize output swing at low supply voltages. Coupling capacitor to the speaker is not required. Open loop gain is 80dB, and the closed loop gain is set with two external resistors. The Mute pin permits powering down and/or muting the input signal.

FEATURES

- *Wide operating supply voltage: $V_{CC}=2V\sim 16V$
- *Low quiescent supply current ($I_{CC}=2.7mA$, typ)
- *Medium output power ($P_{OUT}=250mW$ at $V_{CC}=6V$, $R_L=32\Omega$, THD=10%)
- *Load impedance range (8 to 100ohm)
- *Low distortion
- *Mute function ($I_{CC}=65\mu A$, typ)
- *Minimum number of external parts required

ORDERING INFORMATION

Ordering Number		Package	Packing
Normal	Lead Free Plating		
MC34119-D08-T	MC34119L-D08-T	DIP-8	Tube
MC34119-P08-R	MC34119L-P08-R	TSSOP-8	Tape Reel
MC34119-P08-T	MC34119L-P08-T	TSSOP-8	Tube
MC34119-S08-R	MC34119L-S08-R	SOP-8	Tape Reel
MC34119-S08-T	MC34119L-S08-T	SOP-8	Tube

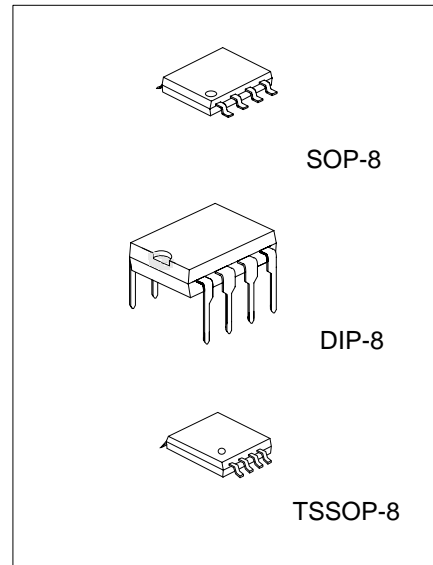

*Pb-free plating product number:MC34119L

<p>MC34119L-D08-T</p> <p>(1)Packing Type (2)Package Type (3)Lead Plating</p>	<p>(1) T: Tube, R: Tape Reel (2) D08: DIP-8, P08: TSSOP-8, S08: SOP-8 (3) L: Lead Free Plating, Blank: Pb/Sn</p>
--	--

■ PIN CONFIGURATION

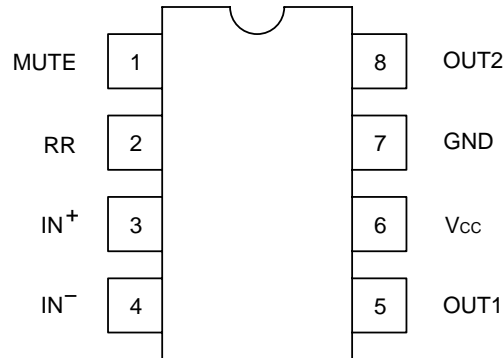

PIN	NAME	DESCRIPTION
1	Mute	This pin can be used to power down the IC to conserve power, or for muting, or both. When at a logic "LOW" (less than 0.8V), the IC is enabled for normal operation. When at a logic "HIGH" (2V to Vcc), the IC is disabled. If Mute is open, that is equivalent to a logic "LOW".
2	Ripple Rejection	A capacitor at this pin increase power supply rejection, and affects turn-on time. This pin can be left open if the capacitor at pin 3 is sufficient.
3	Input(+)	Analog Ground for the amplifiers. A 1 μ F capacitor at this pin (with a 5 μ F capacitor at pin 2) provides 52dB(typ) of power supply rejection. Turn-on time of the circuit is affected by the capacitor on this pin. This pin can be used as an alternative input.
4	Input(-)	Amplifier input. The input capacitor and resistor set low frequency roll-off and input impedance. The feedback resistor is connected between this pin and output 1.
5	Output 1	Amplifier output 1. The DC level is about $(V_{cc}-0.7V)/2$.
6	Vcc	DC supply voltage is applied to this pin($V_{cc}=2\sim 16V$).
7	GND	Ground pin.
8	Output 2	Amplifier output 2. This signal is equal in amplitude, but 180°out of phase with that output 1, the DC level is about $(V_{cc}-0.7V)/2$.

■ BLOCK DIAGRAM

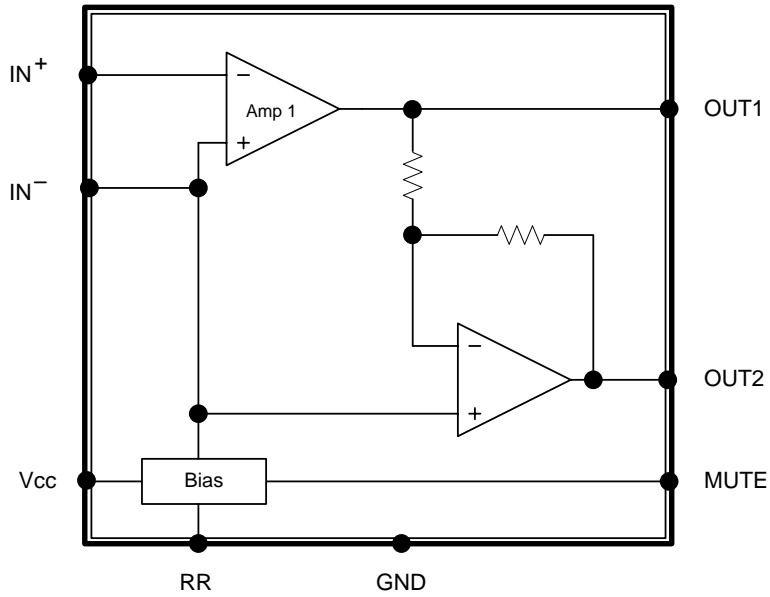

■ ABSOLUTE MAXIMUM RATINGS (Ta=25°C)

PARAMETER	SYMBOL	RATINGS	UNIT
Supply Voltage	V _{CC}	-1~+18	V
Output Current	I _{OUT}	±250	mA
Maximum Input, Ripple Rejection, Mute Pin Voltage	V _{IN}	-1~+1	V
Applied Output Voltage (Output Pin When Disabled)	V _{OUT}	-1~+1	V
Junction Temperature	T _J	+125	°C
Operating Temperature	T _{OPR}	-20 ~ +85	°C
Storage Temperature	T _{STG}	-40 ~ +150	°C

Note: Absolute maximum ratings are those values beyond which the device which the device could be permanently damaged. Absolute maximum ratings are stress ratings only and functional device operation is not implied.

■ RECOMMENDED OPERATION CONDITIONS (Ta=25°C)

PARAMETER	SYMBOL	RATINGS	UNIT
Supply Voltage	V _{CC}	2~16	V
Load Impedance	Z _L	8~100	Ω
Peak Load Current	I _{L(PEAK)}	±200	mA
Differential Gain (5KHz Bandwidth)	ΔGV	0~46	dB
Voltage at Mute	V _{I(MUTE)}	0~V _{CC}	V
Ambient Temperature	T _a	-20~+70	°C

■ ELECTRICAL CHARACTERISTICS (V_{CC}=6V, Ta=25°C, unless otherwise specified)

PARAMETER	SYMBOL	TEST CONDITIONS	MIN	TYP	MAX	UNIT
DC PARAMETER						
Operating Current	I _{CC}	V _{CC} =3V, Mute=0.8V		2.7	4	mA
		V _{CC} =16V, Mute=0.8V		3.3	5	mA
		V _{CC} =3V, Mute=2V		65	100	μA
Output Voltage	V _{OUT}	R _L =16Ω, R ₁ =75KΩ, V _{CC} =3V	1	1.15	1.25	V
		R _L =16Ω, R ₁ =75KΩ, V _{CC} =6V		2.65		V
		R _L =16Ω, R ₁ =75KΩ, V _{CC} =12V		5.65		V
Output Offset Voltage	V _{O(OFF)}	V _{CC} =6V, R _F =75KΩ, R _L =32Ω	-30	0	30	mV
Output High Level	V _{OH}	2V<V _{CC} <16V, I _{OUT} =-75mA		V _{CC} -1		V
Output Low Level	V _{OL}	2V<V _{CC} <16V, I _{OUT} =75mA		0.16		V
Input Bias Current	I _{I(BIAS)}			-100	-200	nA
Equivalent Resistance	R _{EQ}	Pin 3	100	150	220	KΩ
		Pin 2	18	25	40	KΩ
AC PARAMETER						
Open Loop Gain of Amp. 1	Gv1		80			dB
Open Loop Gain of Amp. 2	Gv2	f=1KHz, R _L =32Ω	-0.35	0	0.35	dB
Output Power	P _{OUT}	V _{CC} =3V, R _L =6Ω, THD<10%		55		mW
		V _{CC} =6V, R _L =32Ω, THD<10%		250		mW
		V _{CC} =12V, R _L =100Ω, THD<10%		400		mW
Total Harmonic Distortion (f=1KHz)	THD	V _{CC} =6V, R _L =32Ω, P _{OUT} =125mW		0.5	1	%
		V _{CC} <3V, R _L =8Ω, P _{OUT} =20mW		0.5		%
		V _{CC} <12V, R _L =32Ω, P _{OUT} =200mW		0.6		%
Gain Bandwidth Product	GB _W			1.5		MHz
Power Supply Rejection (V _{CC} =6V, ΔV _{CC} =3V)	RR	C ₁ =∞, C ₂ =0.01μF		50		dB
		C ₁ =0.1μF, C ₂ =0, f=1KHz		12		dB
		C ₁ =1μF, C ₂ =5μF, f=1KHz		52		dB
Muting	Gv(MUTE)	Mute=2V, 1KHz<f<20KHz	70			dB

MC34119

LINEAR INTEGRATED CIRCUIT

■ TYPICAL CIRCUIT

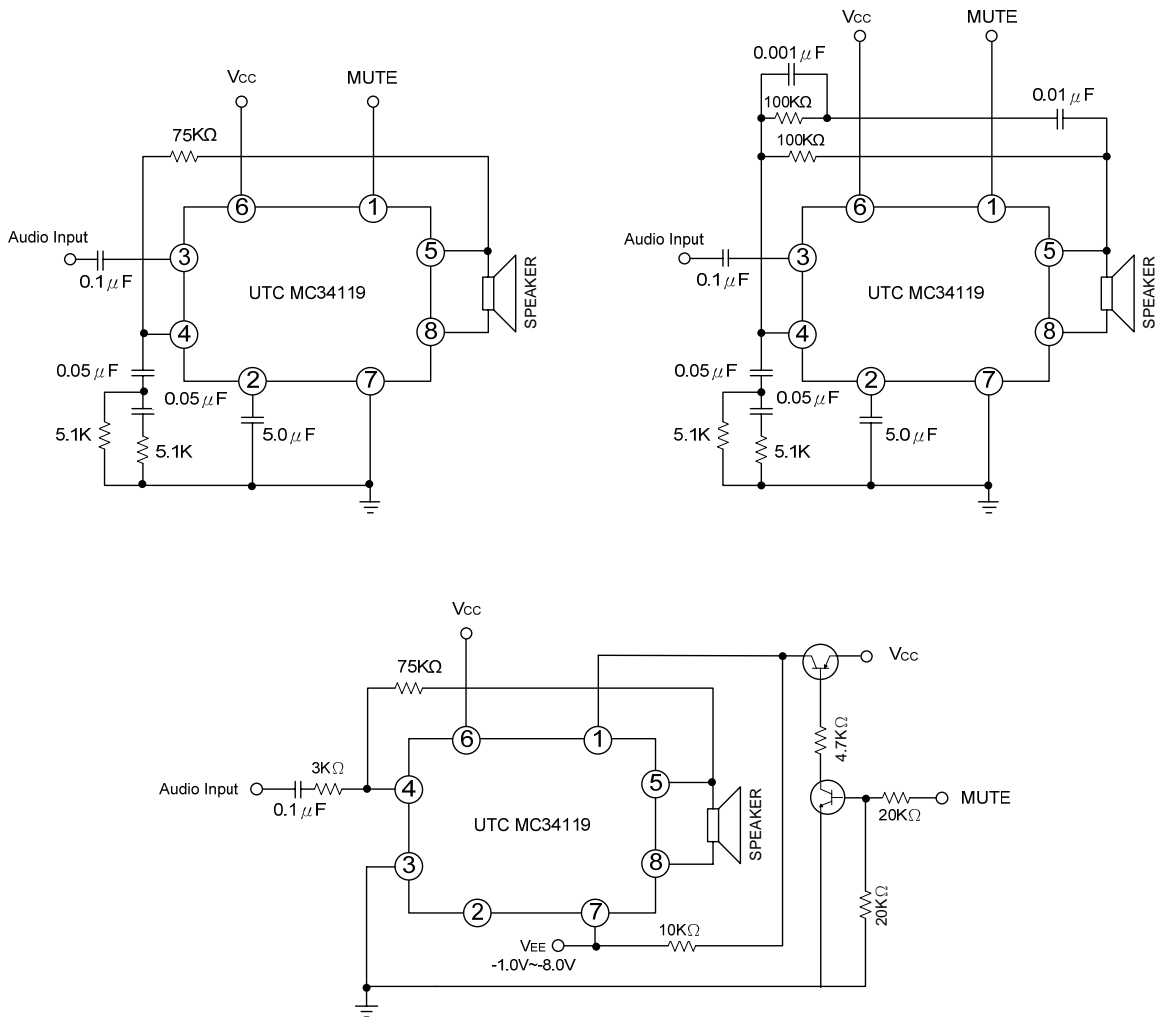

TYPICAL CHARACTERISTICS

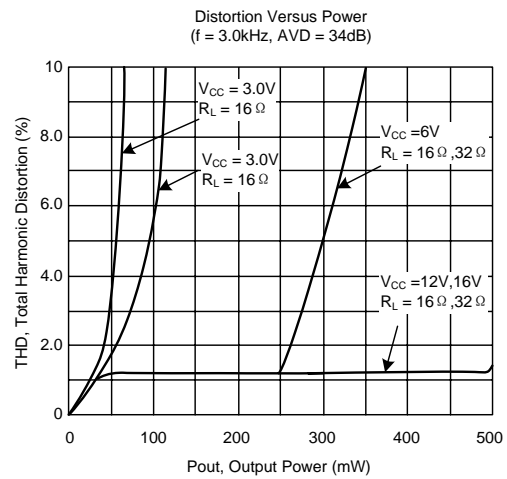
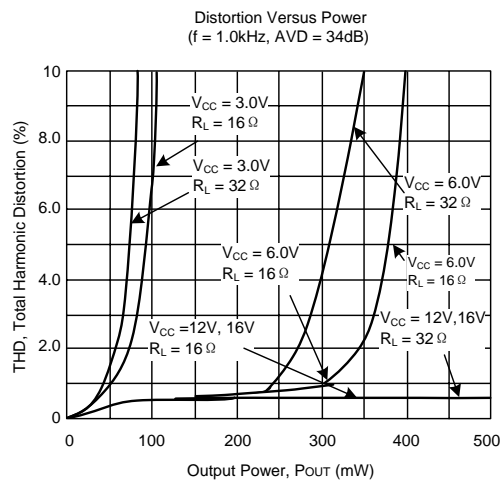
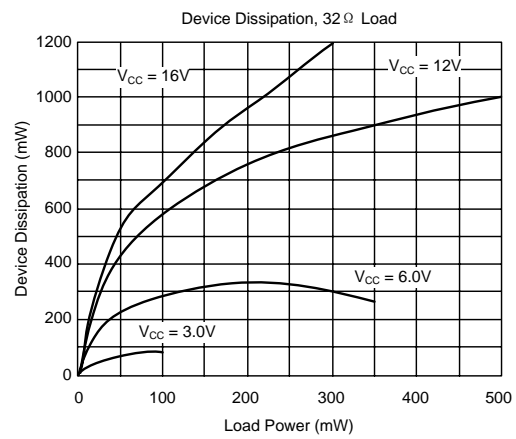
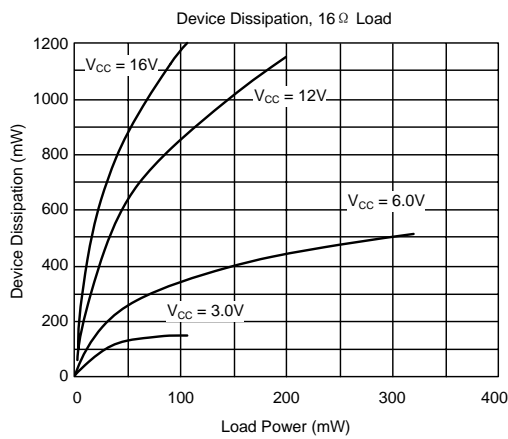
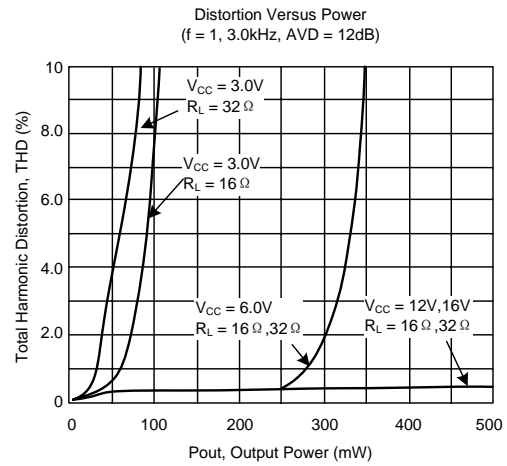
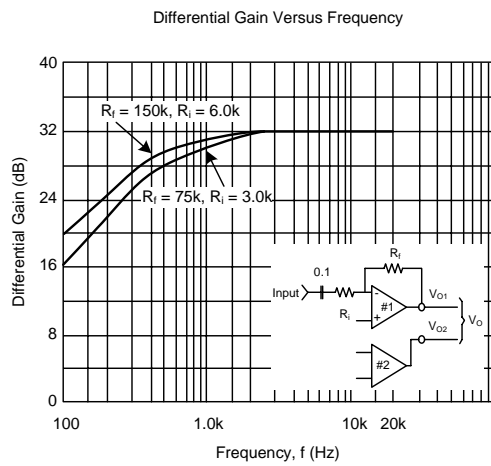

TYPICAL CHARACTERISTICS(Cont.)

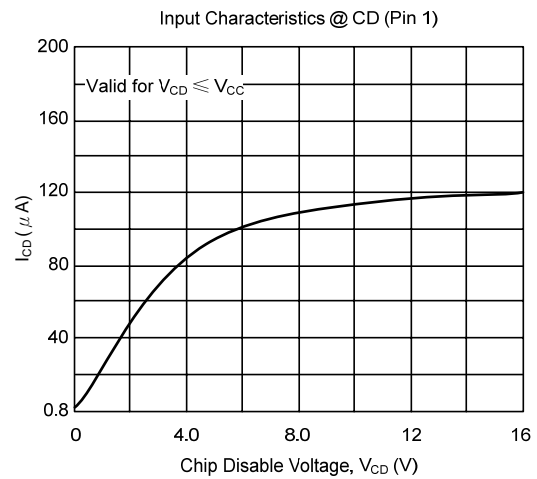
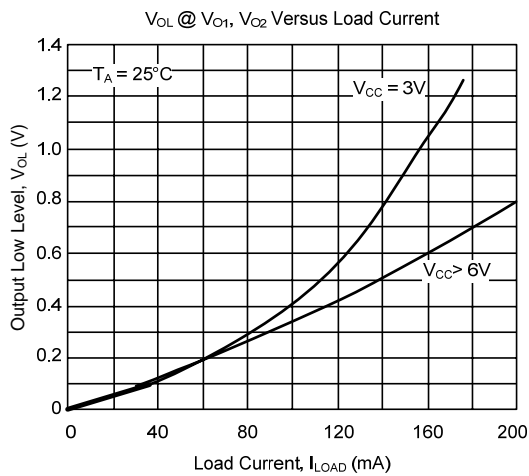
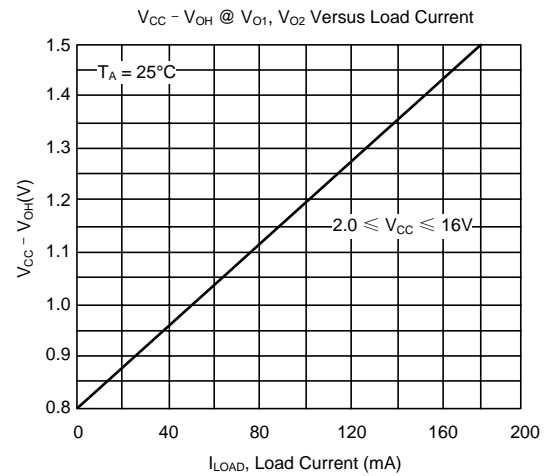
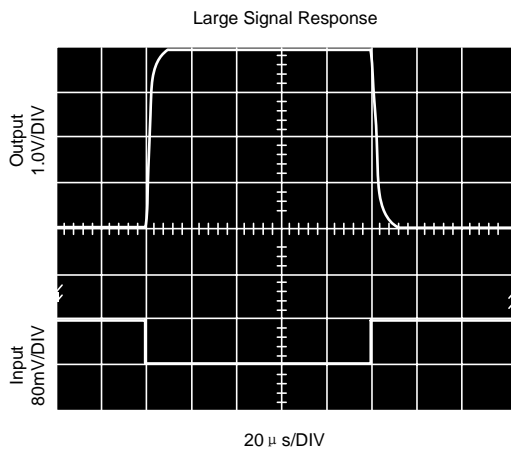
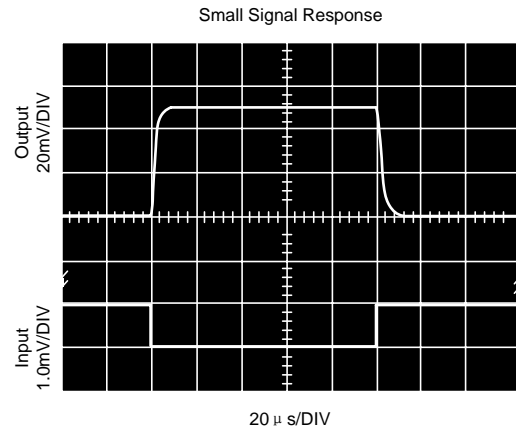
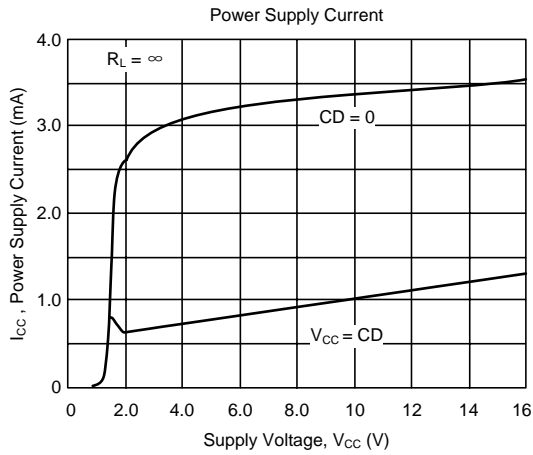

UTC assumes no responsibility for equipment failures that result from using products at values that exceed, even momentarily, rated values (such as maximum ratings, operating condition ranges, or other parameters) listed in products specifications of any and all UTC products described or contained herein. UTC products are not designed for use in life support appliances, devices or systems where malfunction of these products can be reasonably expected to result in personal injury. Reproduction in whole or in part is prohibited without the prior written consent of the copyright owner. The information presented in this document does not form part of any quotation or contract, is believed to be accurate and reliable and may be changed without notice.

