

## **3.3v I/O Controller for Port Replicators and Docking Stations**

**Data Brief**

### **Product Features**

---

- 3.3 Volt Operation (5V Tolerant)
- 32 SMBus-Hosted General Purpose Input/Output Pins
  - SMBus Slave Controller Enables Read/Write Access to GPIO Ports
  - SMBus Runs on and GPIO Pins are Driven by Suspend Supply (VTR)
  - SMBus Interrupt Pin
  - SMBus Isolation Circuitry
- PC99a/PC2001 Compliant
- ACPI 1.0/2.0 Compliant
- Power Management Interface
- LPC Interface
  - Multiplexed Command, Address and Data Bus
  - Serial IRQ Interface Compatible with Serialized IRQ Support for PCI Systems
  - nIO\_PME pin for UART Ring Indicate
  - PCI Clock Run Support
- 4 LPC-Hosted General Purpose Input/Output Pins
- Serial Port
  - Full Function Serial Port
  - High Speed 16C550A Compatible UART with 16-Byte Send/Receive FIFOs
  - Programmable Baud Rate Generator supports 230k and 460k Baud
  - Modem Control Circuitry
  - 480 Address and 15 IRQ Options
  - Ring Indicator Wakeup Event
- Multi-Mode™ Parallel Port with ChiProtect™
  - Standard Mode IBM PC/XT®, PC/AT®, and PS/2™ Compatible Bidirectional Parallel Port
  - Enhanced Parallel Port (EPP) Compatible - EPP 1.7 and EPP 1.9 (IEEE 1284 Compliant)
  - IEEE 1284 Compliant Enhanced Capabilities Port (ECP)
  - ChiProtect Circuitry for Protection
  - 480 Address, Up to 15 IRQ and Three DMA Options
- XNOR-Chain
- 100 pin TQFP lead-free RoHS compliant package

## ORDERING INFORMATION

### Order Number:

LPC47N237-MT for 100 pin TQFP lead-free RoHS compliant package



80 ARKAY DRIVE, HAUPPAUGE, NY 11788 (631) 435-6000, FAX (631) 273-3123

Copyright © 2007 SMSC or its subsidiaries. All rights reserved.

Circuit diagrams and other information relating to SMSC products are included as a means of illustrating typical applications. Consequently, complete information sufficient for construction purposes is not necessarily given. Although the information has been checked and is believed to be accurate, no responsibility is assumed for inaccuracies. SMSC reserves the right to make changes to specifications and product descriptions at any time without notice. Contact your local SMSC sales office to obtain the latest specifications before placing your product order. The provision of this information does not convey to the purchaser of the described semiconductor devices any licenses under any patent rights or other intellectual property rights of SMSC or others. All sales are expressly conditional on your agreement to the terms and conditions of the most recently dated version of SMSC's standard Terms of Sale Agreement dated before the date of your order (the "Terms of Sale Agreement"). The product may contain design defects or errors known as anomalies which may cause the product's functions to deviate from published specifications. Anomaly sheets are available upon request. SMSC products are not designed, intended, authorized or warranted for use in any life support or other application where product failure could cause or contribute to personal injury or severe property damage. Any and all such uses without prior written approval of an Officer of SMSC and further testing and/or modification will be fully at the risk of the customer. Copies of this document or other SMSC literature, as well as the Terms of Sale Agreement, may be obtained by visiting SMSC's website at <http://www.smSC.com>. SMSC is a registered trademark of Standard Microsystems Corporation ("SMSC"). Product names and company names are the trademarks of their respective holders.

**SMSC DISCLAIMS AND EXCLUDES ANY AND ALL WARRANTIES, INCLUDING WITHOUT LIMITATION ANY AND ALL IMPLIED WARRANTIES OF MERCHANTABILITY, FITNESS FOR A PARTICULAR PURPOSE, TITLE, AND AGAINST INFRINGEMENT AND THE LIKE, AND ANY AND ALL WARRANTIES ARISING FROM ANY COURSE OF DEALING OR USAGE OF TRADE. IN NO EVENT SHALL SMSC BE LIABLE FOR ANY DIRECT, INCIDENTAL, INDIRECT, SPECIAL, PUNITIVE, OR CONSEQUENTIAL DAMAGES; OR FOR LOST DATA, PROFITS, SAVINGS OR REVENUES OF ANY KIND; REGARDLESS OF THE FORM OF ACTION, WHETHER BASED ON CONTRACT; TORT; NEGLIGENCE OF SMSC OR OTHERS; STRICT LIABILITY; BREACH OF WARRANTY; OR OTHERWISE; WHETHER OR NOT ANY REMEDY OF BUYER IS HELD TO HAVE FAILED OF ITS ESSENTIAL PURPOSE, AND WHETHER OR NOT SMSC HAS BEEN ADVISED OF THE POSSIBILITY OF SUCH DAMAGES.**



## General Description

---

The LPC47N237 is a 3.3V (5V Tolerant) PC99a/PC2001 compliant Docking I/O controller. The device, which implements the LPC interface, includes I/O functionality. LPC47N237's LPC interface supports LPC I/O and DMA cycles. There is also a SMBus hosted GPIO Block.

The LPC47N237 provides 4 LPC general purpose pins which offer flexibility to the system designer. The legacy I/O included in the LPC47N237 are: a 16C550A compatible UART; one Multi-Mode parallel port including ChiProtect circuitry plus EPP and ECP. The parallel port is compatible with IBM PC/AT architecture, as well as IEEE 1284 EPP and ECP. The LPC47N237 incorporates sophisticated power control circuitry (PCC) which includes support for PME. The PCC supports multiple low power-down modes. The LPC47N237 is ACPI 1.0b/2.0 compatible.

The I/O Address, DMA Channel and hardware IRQ of each logical device in the LPC47N237 may be reprogrammed through the internal configuration registers. There are up to 480 (960 for Parallel Port) I/O address location options, a Serialized IRQ interface, and three DMA channels.

The SMBus hosted GPIO Block includes 32 GPIOs that are powered by standby supply. The GPIOs can be used to assert an interrupt on a change in state of a GPIO. These events are indicated on the nSMBINT pin.

IBM, PC/XT and PC/AT are registered trademarks and PS/2 is a trademark of International Business Machines Corporation.

SMSC is a registered trademark and Ultra I/O, ChiProtect, and Multi-Mode are trademarks of Standard Microsystems Corporation.

# Block Diagram

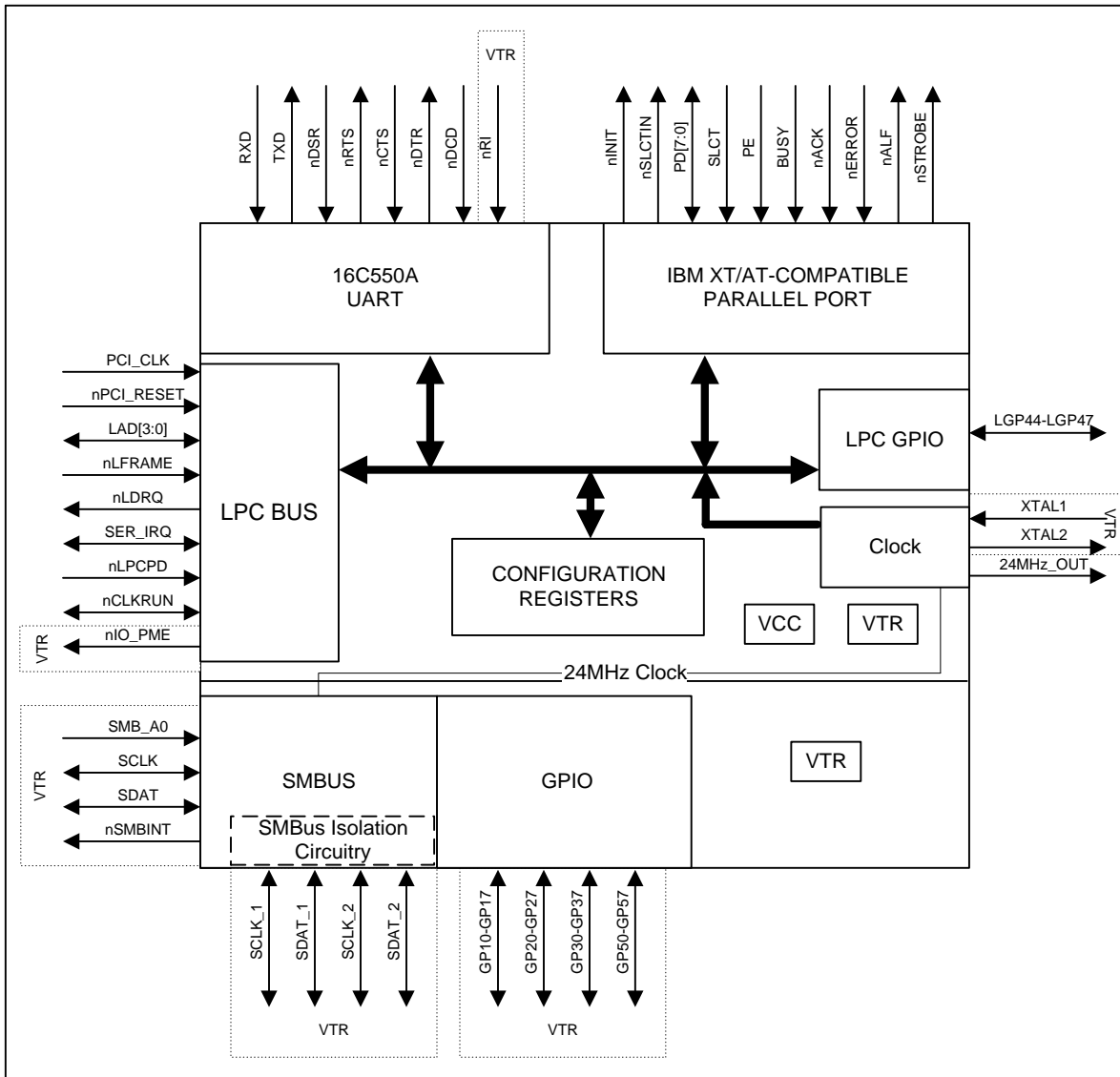
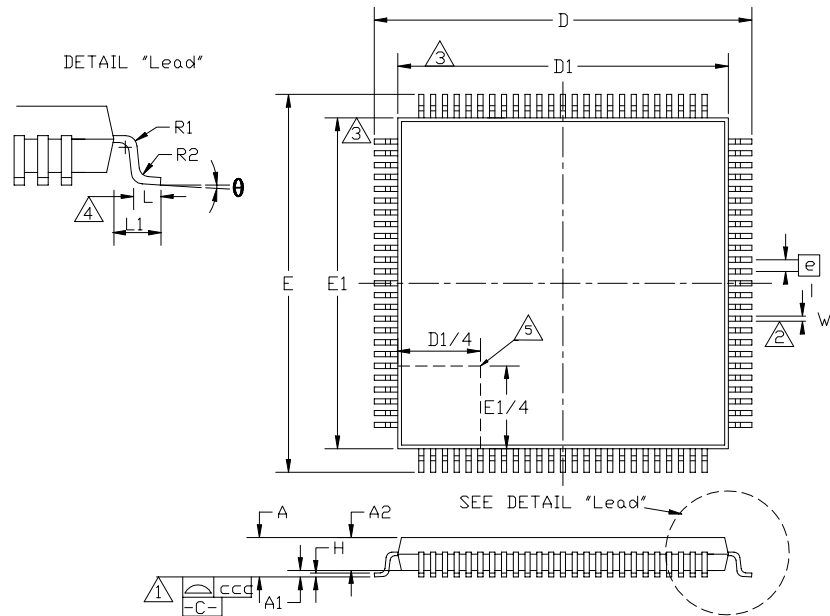

Figure 1 – LPC47N237 Block Diagram

# Package Outline



**Figure 2 – 100 Pin TQFP Package Outline**

**Table 1 – 100 Pin TQFP Package Parameters**

	MIN	NOMINAL	MAX	REMARKS
A	~	~	1.60	Overall Package Height
A1	0.05	~	0.15	Standoff
A2	1.35	~	1.45	Body Thickness
D	15.80	~	16.20	X Span
D1	13.90	~	14.10	X body Size
E	15.80	~	16.20	Y Span
E1	13.90	~	14.10	Y body Size
H	0.09	~	0.20	Lead Frame Thickness
L	0.45	0.60	0.75	Lead Foot Length
L1	~	1.00	~	Lead Length
e	0.50 Basic			Lead Pitch
θ	0°	~	7°	Lead Foot Angle
W	0.17	0.22	0.27	Lead Width
R1	0.08	~	~	Lead Shoulder Radius
R2	0.08	~	0.20	Lead Foot Radius
ccc	~	~	0.08	Coplanarity

**Notes:**

1. Controlling Unit: millimeter.
2. Tolerance on the position of the leads is  $\pm 0.04$  mm maximum.
3. Package body dimensions D1 and E1 do not include the mold protrusion. Maximum mold protrusion is 0.25 mm.
4. Dimension for foot length L measured at the gauge plane 0.25 mm above the seating plane.
5. Details of pin 1 identifier are optional but must be located within the zone indicated.