

3.3v I/O Controller for Port Replicators and Docking Stations

Datasheet

Product Features

- 3.3 Volt Operation (5V Tolerant)
- 32 SMBus-Hosted General Purpose Input/Output Pins
 - SMBus Slave Controller Enables Read/Write Access to GPIO Ports
 - SMBus Runs on and GPIO Pins are Driven by Suspend Supply (VTR)
 - SMBus Interrupt Pin
 - SMBus Isolation Circuitry
- PC99a/PC2001 Compliant
- ACPI 1.0/2.0 Compliant
- Power Management Interface
- LPC Interface
 - Multiplexed Command, Address and Data Bus
 - Serial IRQ Interface Compatible with Serialized IRQ Support for PCI Systems
 - nIO_PME pin for UART Ring Indicate
 - PCI Clock Run Support
- 4 LPC-Hosted General Purpose Input/Output Pins
- Serial Port
 - Full Function Serial Port
 - High Speed 16C550A Compatible UART with 16-Byte Send/Receive FIFOs
 - Programmable Baud Rate Generator supports 230k and 460k Baud
 - Modem Control Circuitry
 - 480 Address and 15 IRQ Options
 - Ring Indicator Wakeup Event
- Multi-Mode™ Parallel Port with ChiProtect™
 - Standard Mode IBM PC/XT®, PC/AT®, and PS/2™ Compatible Bidirectional Parallel Port
 - Enhanced Parallel Port (EPP) Compatible - EPP 1.7 and EPP 1.9 (IEEE 1284 Compliant)
 - IEEE 1284 Compliant Enhanced Capabilities Port (ECP)
 - ChiProtect Circuitry for Protection
 - 480 Address, Up to 15 IRQ and Three DMA Options
- XNOR-Chain
- 100 pin TQFP package; green, lead-free package also available

ORDERING INFORMATION**Order Number(s):**

LPC47N237-MD for 100 pin TQFP package

LPC47N237-MT for 100 pin TQFP package (green, lead-free)



80 Arkay Drive
Hauppauge, NY 11788
(631) 435-6000
FAX (631) 273-3123

Copyright © SMSC 2004. All rights reserved.

Circuit diagrams and other information relating to SMSC products are included as a means of illustrating typical applications. Consequently, complete information sufficient for construction purposes is not necessarily given. Although the information has been checked and is believed to be accurate, no responsibility is assumed for inaccuracies. SMSC reserves the right to make changes to specifications and product descriptions at any time without notice. Contact your local SMSC sales office to obtain the latest specifications before placing your product order. The provision of this information does not convey to the purchaser of the described semiconductor devices any licenses under any patent rights or other intellectual property rights of SMSC or others. All sales are expressly conditional on your agreement to the terms and conditions of the most recently dated version of SMSC's standard Terms of Sale Agreement dated before the date of your order (the "Terms of Sale Agreement"). The product may contain design defects or errors known as anomalies which may cause the product's functions to deviate from published specifications. Anomaly sheets are available upon request. SMSC products are not designed, intended, authorized or warranted for use in any life support or other application where product failure could cause or contribute to personal injury or severe property damage. Any and all such uses without prior written approval of an Officer of SMSC and further testing and/or modification will be fully at the risk of the customer. Copies of this document or other SMSC literature, as well as the Terms of Sale Agreement, may be obtained by visiting SMSC's website at <http://www.smsc.com>. SMSC is a registered trademark of Standard Microsystems Corporation ("SMSC"). Product names and company names are the trademarks of their respective holders.

SMSC DISCLAIMS AND EXCLUDES ANY AND ALL WARRANTIES, INCLUDING WITHOUT LIMITATION ANY AND ALL IMPLIED WARRANTIES OF MERCHANTABILITY, FITNESS FOR A PARTICULAR PURPOSE, TITLE, AND AGAINST INFRINGEMENT AND THE LIKE, AND ANY AND ALL WARRANTIES ARISING FROM ANY COURSE OF DEALING OR USAGE OF TRADE.

IN NO EVENT SHALL SMSC BE LIABLE FOR ANY DIRECT, INCIDENTAL, INDIRECT, SPECIAL, PUNITIVE, OR CONSEQUENTIAL DAMAGES; OR FOR LOST DATA, PROFITS, SAVINGS OR REVENUES OF ANY KIND; REGARDLESS OF THE FORM OF ACTION, WHETHER BASED ON CONTRACT; TORT; NEGLIGENCE OF SMSC OR OTHERS; STRICT LIABILITY; BREACH OF WARRANTY; OR OTHERWISE; WHETHER OR NOT ANY REMEDY OF BUYER IS HELD TO HAVE FAILED OF ITS ESSENTIAL PURPOSE, AND WHETHER OR NOT SMSC HAS BEEN ADVISED OF THE POSSIBILITY OF SUCH DAMAGES.

TABLE OF CONTENTS

Chapter 1	General Description	10
Chapter 2	Pin Configuration.....	11
Chapter 3	Pin Layout.....	12
Chapter 4	Description of Pin Functions	13
4.1	Buffer Name Description	18
4.2	Pins That Require External Resistors	19
Chapter 5	Block Diagram.....	20
Chapter 6	Power/Clock Functionality.....	21
6.1	3.3 Volt Operation / 5 Volt Tolerance	21
6.2	VCC Power.....	21
6.3	VTR Power	21
6.3.1	Trickle Power Functionality	22
6.4	24 MHz Crystal.....	22
6.5	24 MHz Output	22
6.6	Internal PWRGOOD	22
6.7	Maximum Current Values.....	23
6.8	Power Management Events (PME/SCI).....	23
Chapter 7	Functional Description.....	24
7.1	Super I/O Registers	24
7.2	Host Processor Communication.....	24
7.3	LPC Interface	24
7.3.1	LPC Interface Signal Definition	25
	<i>LPC Cycles.....</i>	<i>25</i>
	<i>Field Definitions</i>	<i>25</i>
	<i>nLFRAME Usage</i>	<i>25</i>
	<i>I/O Read and Write Cycles</i>	<i>26</i>
	<i>DMA Read and Write Cycles.....</i>	<i>26</i>
	<i>DMA Protocol</i>	<i>26</i>
7.3.2	Power Management.....	26
	<i>CLOCKRUN Protocol</i>	<i>26</i>
	<i>LPCPD Protocol</i>	<i>26</i>
	<i>SYNC Protocol</i>	<i>27</i>
	<i>Typical Usage.....</i>	<i>27</i>
	<i>SYNC Timeout</i>	<i>27</i>
	<i>SYNC Patterns and Maximum Number of SYNCs.....</i>	<i>27</i>
	<i>SYNC Error Indication</i>	<i>28</i>
	<i>I/O and DMA START Fields</i>	<i>28</i>
	<i>Reset Policy</i>	<i>28</i>
7.3.3	LPC Transfers	28
	<i>Wait State Requirements.....</i>	<i>28</i>
Chapter 8	Serial Port (UART)	29
8.1	Register Description.....	29
8.1.1	Receive Buffer Register (RB).....	29
8.1.2	Transmit Buffer Register (TB).....	30
8.1.3	Interrupt Enable Register (IER).....	30
8.1.4	FIFO Control Register (FCR).....	30
8.1.5	Interrupt Identification Register (IIR).....	31
8.1.6	Line Control Register (LCR).....	33
8.1.7	Modem Control Register (MCR)	34
8.1.8	Line Status Register (LSR).....	35

8.1.9	Modem Status Register (MSR).....	37
8.1.10	Scratchpad Register (SCR).....	38
8.2	Programmable Baud Rate Generator (AND Divisor Latches DLH, DLL)	38
8.3	Effect Of The Reset on Register File	38
8.4	FIFO Interrupt Mode Operation.....	38
8.5	FIFO Polled Mode Operation	39
8.6	Notes On Serial Port Operation	42
8.6.1	FIFO Mode Operation.....	42
8.6.2	TX AND RX FIFO Operation.....	42
Chapter 9	Parallel Port.....	44
9.1	IBM XT/AT Compatible, Bi-Directional And EPP Modes	45
9.1.1	Data Port	45
9.1.2	Status Port.....	45
9.1.3	Control Port	46
9.1.4	EPP Address Port.....	47
9.1.5	EPP Data Port 0	47
9.1.6	EPP Data Port 1	48
9.1.7	EPP Data Port 2	48
9.1.8	EPP Data Port 3	48
9.2	EPP 1.9 Operation	48
9.2.1	Software Constraints	48
9.2.2	EPP 1.9 Write	48
9.2.3	EPP 1.9 Read	49
9.3	EPP 1.7 Operation	50
9.3.1	Software Constraints	50
9.3.2	EPP 1.7 Write	50
9.3.3	EPP 1.7 Read	50
9.4	Extended Capabilities Parallel Port.....	51
9.5	Vocabulary	51
9.6	ECP Implementation Standard.....	53
9.6.1	Description.....	53
9.6.2	Register Definitions.....	54
	<i>Data And ecpAFifo Port.....</i>	<i>55</i>
	<i>Device Status Register (DSR).....</i>	<i>55</i>
	<i>Device Control Register (DCR).....</i>	<i>56</i>
	<i>cFifo (Parallel Port Data FIFO).....</i>	<i>57</i>
	<i>ecpDFifo (ECP Data FIFO).....</i>	<i>57</i>
	<i>tFifo (Test FIFO Mode).....</i>	<i>57</i>
	<i>cnfgA (Configuration Register A).....</i>	<i>58</i>
	<i>cnfgB (Configuration Register B).....</i>	<i>58</i>
	<i>ecr (Extended Control Register).....</i>	<i>58</i>
9.6.3	Operation.....	61
	<i>Mode Switching/Software Control</i>	<i>61</i>
	<i>ECP Operation</i>	<i>61</i>
	<i>Termination from ECP Mode.....</i>	<i>61</i>
	<i>Command/Data</i>	<i>62</i>
	<i>Data Compression.....</i>	<i>62</i>
	<i>Pin Definition</i>	<i>62</i>
	<i>LPC Connections.....</i>	<i>62</i>
	<i>Interrupts.....</i>	<i>63</i>
	<i>FIFO Operation</i>	<i>63</i>
	<i>DMA Transfers</i>	<i>63</i>
	<i>DMA Mode - Transfers from the FIFO to the Host.....</i>	<i>64</i>
	<i>Programmed I/O Mode or Non-DMA Mode</i>	<i>64</i>
	<i>Programmed I/O - Transfers from the FIFO to the Host</i>	<i>64</i>
	<i>Programmed I/O - Transfers from the Host to the FIFO</i>	<i>65</i>
Chapter 10	Power Management.....	66

10.1	UART Power Management	66
10.1.1	Exit Auto Powerdown	66
10.2	Parallel Port Power Management	66
10.2.1	Exit Auto Powerdown	67
Chapter 11	Serial IRQ.....	68
11.1	Timing Diagrams For SER_IRQ Cycle	68
11.1.1	SER_IRQ Cycle Control	69
11.1.2	SER_IRQ Data Frame	69
11.1.3	Stop Cycle Control	70
11.1.4	Latency.....	70
11.1.5	EOI/ISR Read Latency	70
11.1.6	AC/DC Specification Issue	70
11.1.7	Reset and Initialization	71
Chapter 12	PCI CLKRUN Support	72
12.1	Overview	72
12.2	nCLKRUN for Serial IRQ	72
12.3	nCLKRUN for nLDRQ	72
12.4	Using nCLKRUN	72
Chapter 13	LPC General Purpose I/O.....	75
13.1	Description	75
13.2	GPIO Control.....	75
13.3	GPIO Operation	76
Chapter 14	PME Support.....	78
Chapter 15	SMBus GPIO Block.....	79
15.1	SMBus Slave Controller	79
15.1.1	SMBus Pins.....	79
15.1.2	Bus Protocols	80
	Write Byte.....	80
	Read Byte.....	80
15.1.3	Slave Address	80
15.1.4	Invalid Protocol Response Behavior.....	81
15.1.5	General Call Address Response	81
15.1.6	Slave Device Time-Out	81
15.1.7	Stretching the SCLK Signal.....	81
15.1.8	SMBus Timing.....	81
15.1.9	Bus Reset Sequence	81
15.1.10	SMBus Alert Response	82
15.2	SMBus Isolation Logic	82
15.3	SMBus Controlled GPIOs	83
15.3.1	GPIO Pins	84
15.4	SMBus GPIO Registers	84
15.4.1	Direction Registers.....	84
15.4.2	Output Type Registers	84
15.4.3	Data Registers	84
15.4.4	GPIO Mask Registers	84
15.4.5	GPIO Change Status Register	85
15.5	Operation of SMBus Interrupt	85
Chapter 16	Runtime Registers.....	89
16.1	Runtime Registers Block Summary	89
16.2	Runtime Registers Block Description	89
Chapter 17	Configuration	91
17.1	Configuration Access Ports.....	91

17.2	Configuration State	91
17.2.1	Entering the Configuration State	91
17.2.2	Configuration Register Programming	92
17.2.3	Exiting the Configuration State	92
17.2.4	Programming Example	92
17.2.5	Configuration Select Register (CSR)	92
17.3	Configuration Registers Summary	93
17.4	Configuration Registers Description	95
17.4.1	CR00	95
17.4.2	CR01	95
17.4.3	CR02	96
17.4.4	CR03	96
17.4.5	CR04	97
17.4.6	CR05 – CR06	97
17.4.7	CR07	97
17.4.8	CR08	98
17.4.9	CR09	98
17.4.10	CR0A	98
17.4.11	CR0B	99
17.4.12	CR0C	99
17.4.13	CR0D	99
17.4.14	CR0E	99
17.4.15	CR0F	99
17.4.16	CR10	100
17.4.17	CR11	100
17.4.18	CR12 - CR13	101
17.4.19	CR14	102
17.4.20	CR15	102
17.4.21	CR16 – CR20	102
17.4.22	CR21	103
17.4.23	CR22	103
17.4.24	CR23	103
17.4.25	CR24	104
17.4.26	CR25	104
17.4.27	CR26	105
17.4.28	CR27	105
17.4.29	CR28	106
17.4.30	CR29	107
17.4.31	CR2A – CR2E	107
17.4.32	CR2F – CR30	107
17.4.33	CR31 – CR36	108
17.4.34	CR37	108
17.4.35	CR38	109
17.4.36	CR39	109
17.5	Logical Device Base I/O Address and Range	110
17.6	Note A. Logical Device IRQ and DMA Operation	111
Chapter 18	SMBus GPIO Register Map	112
18.1	SMBus GPIO Register Summary	112
18.2	SMBus GPIO Register Description	112
Chapter 19	Operational Description	118
19.1	Maximum Guaranteed Ratings	118
19.2	DC Electrical Characteristics	118
Chapter 20	Timing Diagrams	122
20.1	ECP Parallel Port Timing	129
20.1.1	Parallel Port FIFO (Mode 101)	129
20.1.2	ECP Parallel Port Timing	129
20.1.3	Forward-Idle	129

20.1.4	Forward Data Transfer Phase	129
20.1.5	Reverse-Idle Phase.....	129
20.1.6	Reverse Data Transfer Phase.....	129
20.1.7	Output Drivers	130
Chapter 21	XNOR-Chain Test Mode.....	135
21.1	Entering and Exiting Test Mode.....	135
21.1.1	XNOR-Chain test mode can be entered as follows:	135
21.1.2	XNOR-Chain test mode can be exited as follows:.....	135
21.2	Pin List of XNOR Chain	136
21.3	Setup of XNOR Chain.....	136
21.4	Testing Procedure.....	136
Chapter 22	Package Outline	138

LIST OF FIGURES

Figure 3.1	– LPC47N237 Pin Layout.....	12
Figure 5.1	– LPC47N237 Block Diagram	20
Figure 8.1	- Serial Data	33
Figure 11.1	A. Start Frame timing with source sampled a low pulse on IRQ1.....	68
Figure 11.2	B. Stop Frame Timing with Host using 17 SER_IRQ sampling period	68
Figure 12.1	– nCLKRUN System Implementation Example	73
Figure 12.2	– Clock Start Illustration	74
Figure 13.1	- GPIO Function Illustration	76
Figure 15.1	– SMBus Isolation Switch.....	83
Figure 15.2	- GPIO Transition Cases	86
Figure 15.3	– Sample Representation of nSMBINT Assertion Logic.....	88
Figure 20.1	- POWER-UP TIMING.....	122
Figure 20.2	– 24MHz_OUT CLOCK TIMING	123
Figure 20.3	– PCI CLOCK TIMING	123
Figure 20.4	- RESET TIMING	123
Figure 20.5	– Output Timing Measurement Conditions, LPC Signals	124
Figure 20.6	– Input Timing Measurement Conditions, LPC Signals	124
Figure 20.7	– LPC I/O Write	124
Figure 20.8	– LPC I/O Read.....	125
Figure 20.9	– DMA Request Assertion Through nLDRQ.....	125
Figure 20.10	– LPC DMA Write (First Byte)	125
Figure 20.11	– LPC DMA Read (First Byte)	125
Figure 20.12	– EPP 1.9 Data or Address Write Cycle.....	126
Figure 20.13	– EPP 1.9 Data or Address Read Cycle.....	127
Figure 20.14	– EPP 1.7 Data or Address Write Cycle.....	128
Figure 20.15	– EPP 1.7 Data or Address Read Cycle.....	128
Figure 20.16	– Parallel Port FIFO Timing.....	130
Figure 20.17	- ECP Parallel Port Forward Timing	131
Figure 20.18	- ECP Parallel Port Reverse Timing.....	132
Figure 20.19	– SER_IRQ Setup and Hold Time	133
Figure 20.20	– Serial Port Data.....	133
Figure 20.21	– SMBus Timing.....	134
Figure 21.1	– XNOR-CHAIN TEST STRUCTURE	135
Figure 22.1	– 100 Pin TQFP Package Outline	138

LIST OF TABLES

Table 2.1	– LPC47N237 Pin Configuration	11
Table 4.1	– Pin Description	13
Table 7.1	- Super I/O Block Addresses	24

Table 8.1 - Addressing the Serial Port	29
Table 8.2 – UART Interrupt Control Table	32
Table 8.3 – UART Baud Rates	39
Table 8.4 – UART Reset Function Table	40
Table 8.5 – Register Summary for an Individual UART Channel	41
Table 9.1 - Parallel Port Connector	45
Table 9.2 - EPP Pin Descriptions	51
Table 9.3 - ECP Pin Descriptions	53
Table 9.4 - ECP Register Definitions	54
Table 9.5 – Parallel Port Mode Description	55
Table 9.6 - Extended Control Register	60
Table 9.7 - Parallel Port IRQ Selection	60
Table 9.8 - Parallel Port DMA Selection	60
Table 9.9 – ECP Forward/Reserve Channel Commands	62
Table 11.1 - SER_IRQ Sampling Periods	69
Table 12.1 – LPC47N237 nCLKRUN Function	73
Table 13.1 – General Purpose I/O Port Assignments	75
Table 13.2 - GPIO Configuration Summary	76
Table 13.3 – GPIO Read/Write Behavior	77
Table 15.1 – SMBus Pins	80
Table 15.2 – SMBus Write Byte Protocol	80
Table 15.3 – SMBus Read Byte Protocol	80
Table 15.4 – SMBus GPIO Pins	84
Table 15.5 – SMBus GPIO Events State Table in LPC47N237	86
Table 16.1 - Runtime Register Block Summary	89
Table 16.2 – Runtime Registers Block Description	89
Table 17.1 – Configuration Access Ports	91
Table 17.2 – Configuration Registers Summary	93
Table 17.3 – CR00	95
Table 17.4 – CR01	96
Table 17.5 – CR02	96
Table 17.6 – CR04	97
Table 17.7 – CR07	98
Table 17.8 – CR09	98
Table 17.9 – CR0A	99
Table 17.10 – CR0C	99
Table 17.11 – CR0F	100
Table 17.12 – CR10	100
Table 17.13 – CR11	101
Table 17.14 – CR12	101
Table 17.15 – CR13	102
Table 17.16 - CR15	102
Table 17.17 – CR21	103
Table 17.18 - CR22	103
Table 17.19 - CR23	104
Table 17.20 - Parallel Port Addressing Options	104
Table 17.21 - CR24	104
Table 17.22 - CR26	105
Table 17.23 - DMA Selection	105
Table 17.24 - CR27	105
Table 17.25 – IRQ Encoding	106
Table 17.26 – CR28	106
Table 17.27 – UART Interrupt Operation	107
Table 17.28 – CR29	107
Table 17.29 – CR2F	108
Table 17.30 – CR30	108
Table 17.31 – CR37	109
Table 17.32 – CR38	109
Table 17.33 – CR39	110
Table 17.34 – I/O Base Address Configuration Register Description	110



Table 18.1 – SMBus GPIO Register Summary 112
Table 18.2 – SMBus GPIO Register Description..... 112
Table 22.1 – 100 Pin TQFP Package Parameters 138

Chapter 1 General Description

The LPC47N237 is a 3.3V (5V Tolerant) PC99a/PC2001 compliant Docking I/O controller. The device, which implements the LPC interface, includes I/O functionality. LPC47N237's LPC interface supports LPC I/O and DMA cycles. There is also a SMBus hosted GPIO Block.

The LPC47N237 provides 4 LPC general purpose pins which offer flexibility to the system designer. The legacy I/O included in the LPC47N237 are: a 16C550A compatible UART; one Multi-Mode parallel port including ChiProtect circuitry plus EPP and ECP. The parallel port is compatible with IBM PC/AT architecture, as well as IEEE 1284 EPP and ECP. The LPC47N237 incorporates sophisticated power control circuitry (PCC) which includes support for PME. The PCC supports multiple low power-down modes. The LPC47N237 is ACPI 1.0b/2.0 compatible.

The I/O Address, DMA Channel and hardware IRQ of each logical device in the LPC47N237 may be reprogrammed through the internal configuration registers. There are up to 480 (960 for Parallel Port) I/O address location options, a Serialized IRQ interface, and three DMA channels.

The SMBus hosted GPIO Block includes 32 GPIOs that are powered by standby supply. The GPIOs can be used to assert an interrupt on a change in state of a GPIO. These events are indicated on the nSMBINT pin.

Chapter 2 Pin Configuration

Table 2.1 shows the pin configuration of LPC47N237. This pin configuration is subject to change.

Table 2.1 – LPC47N237 Pin Configuration

PIN #	NAME	PIN #	NAME	PIN #	NAME	PIN #	NAME
1	VTR	26	nPCI_RESET	51	GP13	76	VSS
2	SDAT_1	27	nLPCPD	52	GP14	77	SLCT
3	SDAT	28	nCLKRUN	53	VCC	78	PE
4	SDAT_2	29	PCI_CLK	54	GP15	79	BUSY
5	SMB_A0	30	SER_IRQ	55	GP16	80	nACK
6	nSMBINT	31	VSS	56	VSS	81	nERROR
7	VSS	32	VTR	57	GP20	82	nALF
8	SCLK_1	33	GP31	58	GP21	83	nSTROBE
9	SCLK	34	GP32	59	GP22	84	RXD
10	SCLK_2	35	GP33	60	VSS	85	TXD
11	GP30	36	GP34	61	XTAL1	86	nDSR
12	GP37	37	GP35	62	XTAL2	87	nRTS
13	VCC	38	GP36	63	VTR	88	nCTS
14	GP23	39	VSS	64	24MHz_OUT	89	nDTR
15	GP10	40	GP24	65	VCC	90	nRI
16	GP17	41	GP25	66	nINIT	91	nDCD
17	nIO_PME	42	GP26	67	nSLCTIN	92	GP50
18	VTR	43	GP27	68	PD0	93	VCC
19	VSS	44	LGP44	69	PD1	94	GP51
20	LAD0	45	LGP45	70	PD2	95	GP52
21	LAD1	46	LGP46	71	PD3	96	GP53
22	LAD2	47	LGP47/ SYSOPT	72	PD4	97	GP54
23	LAD3	48	VCC	73	PD5	98	GP55
24	nLFRAME	49	GP11	74	PD6	99	GP56
25	nLDRQ	50	GP12	75	PD7	100	GP57

Chapter 3 Pin Layout

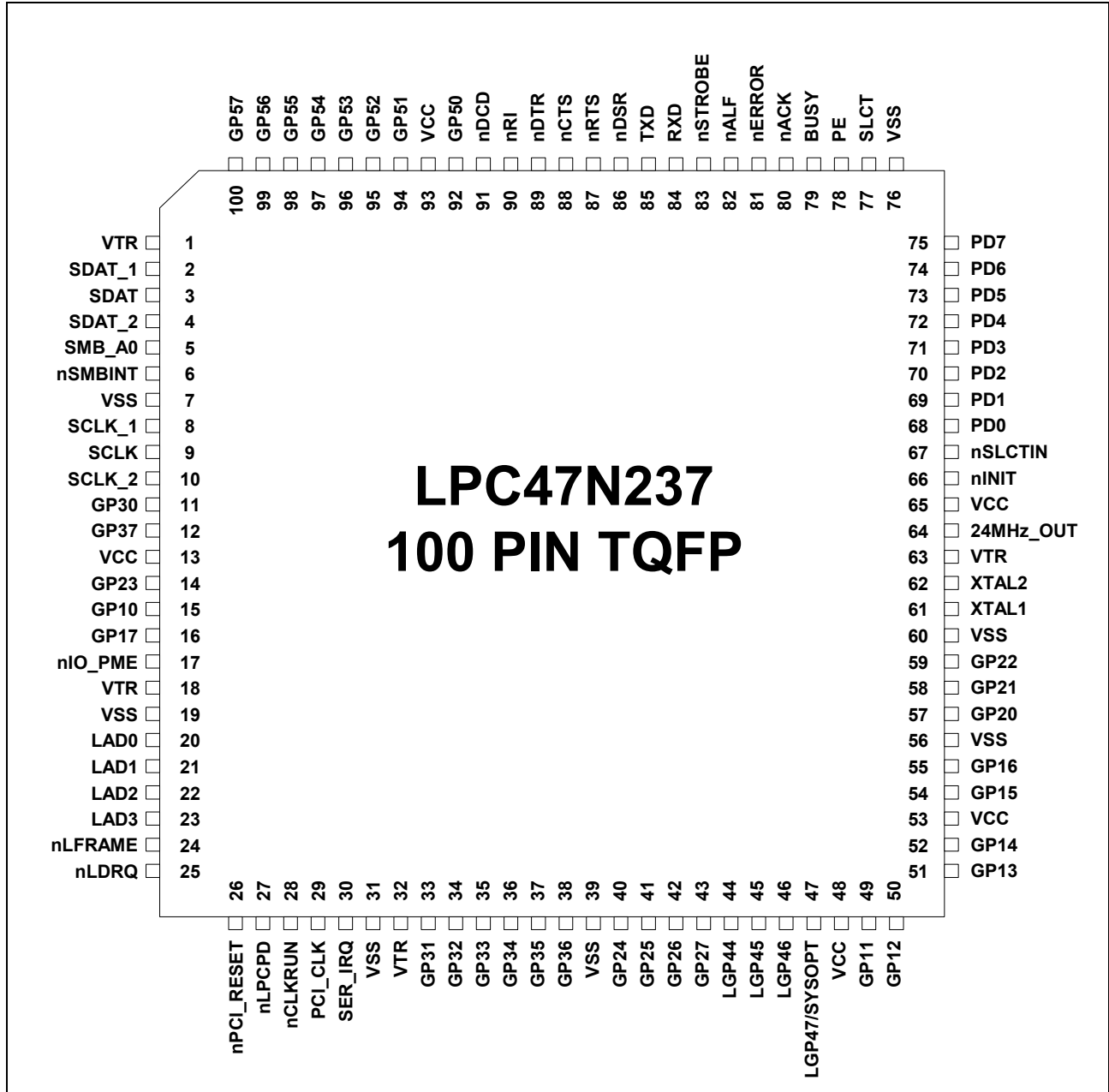

Figure 3.1 – LPC47N237 Pin Layout

Chapter 4 Description of Pin Functions

Table 4.1 – Pin Description

PIN#	NAME (NOTE 4.1)	DESCRIPTION	BUFFER NAME (NOTE 4.2)	PWR WELL (NOTE 4.3)	NOTES
POWER PINS (16)					
1, 18, 32, 63	VTR	+3.3 Volt Standby Supply Voltage (4)			
13, 48, 53, 65, 93	VCC	+3.3 Volt Supply Voltage (5)			
7, 19, 31, 39, 56, 60, 76	VSS	Ground (7)			
CLOCKS (3)					
61	XTAL1	24MHz Crystal Clock Input. It can also be used as single-ended oscillator clock input.	ICLK	VTR	(Note 4.4)
62	XTAL2	24MHz Crystal Clock Output	OCLK	VTR	(Note 4.4)
64	24MHz_OUT	24MHz Clock Output	O12	VCC	(Note 4.5)
PROCESSOR/HOST LPC INTERFACE (12)					
17	nIO_PME	This active low Power Management signal allows to request wakeup. It can be configured to be Push-Pull output	OD12	VTR	
23:20	LAD[3:0]	Active high LPC I/O used for multiplexed command, address and data bus.	PCI_IO	VCC	
24	nLFRAME	Active low input indicates start of new cycle and termination of broken cycle.	PCI_I	VCC	
25	nLDRQ	Active low output used for encoded DMA/Bus Master request for the LPC interface.	PCI_O	VCC	
26	nPCI_RESET	Active low input used as LPC Interface Reset.	PCI_I	VCC	
27	nLPCPD	Active low input Power Down signal indicates that the LPC47N237 should prepare for power to be shut-off on the LPC interface.	PCI_I	VCC	(Note 4.6)
28	nCLKRUN	This signal is used to indicate the PCI clock status and to request that a stopped clock be started.	PCI_IOD	VCC	
29	PCI_CLK	PCI clock input.	PCI_ICLK	VCC	
30	SER_IRQ	Serial IRQ pin used with the PCI_CLK pin to transfer LPC47N237 interrupts to the host.	PCI_IO	VCC	
SERIAL PORT INTERFACE (8)					
84	RXD	Receiver serial data input.	IS	VCC	
85	TXD	Transmit serial data output.	O12	VCC	

PIN#	NAME (NOTE 4.1)	DESCRIPTION	BUFFER NAME (NOTE 4.2)	PWR WELL (NOTE 4.3)	NOTES
86	nDSR	Active low Data Set Ready input for the serial port. Handshake signal which notifies the UART that the modem is ready to establish the communication link. The CPU can monitor the status of nDSR signal by reading bit 5 of Modem Status Register (MSR). A nDSR signal state change from low to high after the last MSR read will set MSR bit 1 to a 1. If bit 3 of Interrupt Enable Register is set, the interrupt is generated when nDSR changes state. Note: Bit 5 of MSR is the complement of nDSR.	I	VCC	
87	nRTS	Active low Request to Send outputs for the Serial Port. Handshake output signal notifies modem that the UART is ready to transmit data. This signal can be programmed by writing to bit 1 of the Modem Control Register (MCR). The hardware reset will reset the nRTS signal to inactive mode (high). nRTS is forced inactive during loop mode operation.	O8	VCC	
88	nCTS	Active low Clear to Send inputs for the serial port. Handshake signal which notifies the UART that the modem is ready to receive data. The CPU can monitor the status of nCTS signal by reading bit 4 of Modem Status Register (MSR). A nCTS signal state change from low to high after the last MSR read will set MSR bit 0 to a 1. If bit 3 of the Interrupt Enable Register is set, the interrupt is generated when nCTS changes state. The nCTS signal has no effect on the transmitter. Note: Bit 4 of MSR is the complement of nCTS.	I	VCC	
89	nDTR	Active low Data Terminal Ready outputs for the serial port. Handshake output signal notifies modem that the UART is ready to establish data communication link. This signal can be programmed by writing to bit 0 of Modem Control Register (MCR). The hardware reset will reset the nDTR signal to inactive mode (high). nDTR is forced inactive during loop mode operation.	O8	VCC	

PIN#	NAME (NOTE 4.1)	DESCRIPTION	BUFFER NAME (NOTE 4.2)	PWR WELL (NOTE 4.3)	NOTES
90	nRI	Active low Ring Indicator inputs for the serial port. Handshake signal which notifies the UART that the telephone ring signal is detected by the modem. The CPU can monitor the status of nRI signal by reading bit 6 of Modem Status Register (MSR). A nRI signal state change from low to high after the last MSR read will set MSR bit 2 to a 1. If bit 3 of Interrupt Enable Register is set, the interrupt is generated when nRI changes state. Note: Bit 6 of MSR is the complement of nRI. This pin can be used for wakeup.	I	VTR	(Note 4.7)
91	nDCD	Active low Data Carrier Detect inputs for the serial port. Handshake signal which notifies the UART that carrier signal is detected by the modem. The CPU can monitor the status of nDCD signal by reading bit 7 of Modem Status Register (MSR). A nDCD signal state change from low to high after the last MSR read will set MSR bit 3 to a 1. If bit 3 of Interrupt Enable Register is set, the interrupt is generated when nDCD changes state. Note: Bit 7 of MSR is the complement of nDCD.	I	VCC	
PARALLEL PORT INTERFACE (17)					
66	nINIT	This output is bit 2 of the printer control register. This is used to initiate the printer when low. Refer to Parallel Port description for use of this pin in ECP and EPP mode. Can be configured as an Open-Drain Output.	OP14	VCC	
67	nSLCTIN	This active low output selects the printer. This is the complement of bit 3 of the Printer Control Register. Refer to Parallel Port description for use of this pin in ECP and EPP mode. Can be Configured as an Open-Drain Output.	OP14	VCC	
68	PD0	Port Data 0 I/O	IOP14	VCC	
69	PD1	Port Data 1 I/O	IOP14	VCC	
70	PD2	Port Data 2 I/O	IOP14	VCC	
71	PD3	Port Data 3 I/O	IOP14	VCC	
72	PD4	Port Data 4 I/O	IOP14	VCC	
73	PD5	Port Data 5 I/O	IOP14	VCC	
74	PD6	Port Data 6 I/O	IOP14	VCC	
75	PD7	Port Data 7 I/O	IOP14	VCC	

PIN#	NAME (NOTE 4.1)	DESCRIPTION	BUFFER NAME (NOTE 4.2)	PWR WELL (NOTE 4.3)	NOTES
77	SLCT	This high active input from the printer indicates that it has power on. Bit 4 of the Printer Status Register reads the SLCT input. Refer to Parallel Port description for use of this pin in ECP and EPP mode.	I	VCC	
78	PE	Another status input from the printer, a high indicating that the printer is out of paper. Bit 5 of the Printer Status Register reads the PE input. Refer to Parallel Port description for use of this pin in ECP and EPP mode.	I	VCC	
79	BUSY	This is a status input from the printer, a high indicating that the printer is not ready to receive new data. Bit 7 of the Printer Status Register is the complement of the BUSY input. Refer to Parallel Port description for use of this pin in ECP and EPP mode.	I	VCC	
80	nACK	A low active input from the printer indicating that it has received the data and is ready to accept new data. Bit 6 of the Printer Status Register reads the nACK input. Refer to Parallel Port description for use of this pin in ECP and EPP mode.	I	VCC	
81	nERROR	A low on this input from the printer indicates that there is a error condition at the printer. Bit 3 of the Printer Status register reads the nERR input. Refer to Parallel Port description for use of this pin in ECP and EPP mode.	I	VCC	
82	nALF	This output goes low to cause the printer to automatically feed one line after each line is printed. The nALF output is the complement of bit 1 of the Printer Control Register. Refer to Parallel Port description for use of this pin in ECP and EPP mode. Can be configured as an Open-Drain Output.	OP14	VCC	
83	nSTROBE	An active low pulse on this output is used to strobe the printer data into the printer. The nSTROBE output is the complement of bit 0 of the Printer Control Register. Refer to Parallel Port description for use of this pin in ECP and EPP mode. Can be configured as an Open-Drain Output.	OP14	VCC	
LPC GENERAL PURPOSE I/O (4)					
44-46	LGP44- LGP46	General Purpose I/O. These pins default as inputs.	IO8	VCC	

PIN#	NAME (NOTE 4.1)	DESCRIPTION	BUFFER NAME (NOTE 4.2)	PWR WELL (NOTE 4.3)	NOTES
47	LGP47 (SYSOPT)	LPC General Purpose I/O. System Option. At trailing edge of hardware reset this pin is latched to determine the configuration base address: 0=Index Base I/O Address 0x2E; 1=Index Base I/O Address 0x4E.	IO8	VCC	(Note 4.8)
SMBus GPIO BLOCK (40)					
9	SCLK	SMBus Clock IOD	IS2OD12	VTR	
3	SDAT	SMBus Data IOD	IS2OD12	VTR	
6	nSMBINT	SMBus Interrupt Open-Drain Output	OD8	VTR	
5	SMB_A0	LSB of SMBus Address sampled on VTR POR. Connect to GND or pull-up to VTR.	I	VTR	
15,49, 50,51, 52,54, 55,16	GP10-GP17	SMBus Controlled General Purpose I/O. The GPIOs can be programmed as open-drain output. These pins are either-edge wakeup inputs and can be driven under VTR power. The default is input on VTR POR.	IO8	VTR	
57- 59, 14, 40-43	GP20-GP27				
11, 33- 38, 12	GP30-GP37				
92, 94- 100	GP50-GP57				
8	SCLK_1	SMBus Clock 1 IOD. This is an SMBus Clock pin that can be isolated from the SCLK pin (in conjunction with SDAT_1)	IS2OD12	VTR	
2	SDAT_1	SMBus Data 1 IOD. This is an SMBus Data pin that can be isolated from the SDAT pin (in conjunction with SCLK_1)	IS2OD12	VTR	
10	SCLK_2	SMBus Clock 2 IOD. This is an SMBus Clock pin that can be isolated from the SCLK pin (in conjunction with SDAT_2)	IS2OD12	VTR	
4	SDAT_2	SMBus Data 2 IOD. This is an SMBus Data pin that can be isolated from the SDAT pin (in conjunction with SCLK_2)	IS2OD12	VTR	

- Note 4.1** The “n” as the first letter of a signal name or the “#” as the suffix of a signal name indicates an “Active Low” signal.
- Note 4.2** The Buffers are described in the “Buffer Name Description” section.
- Note 4.3** Pins that require external pull-ups (including open-drain outputs) are listed in the “Pins That Require External Resistors” section and should be pulled to the supply shown in the power well column. Other output pins are driven under the power well shown. Inputs pins that are shown under suspend power well are design dependent and may not be active under suspend power.
- Note 4.4** The 24MHz XTAL is active under VTR power when VCC is off. This is the clock source to the SMBus block.
- Note 4.5** The 24MHz output is active under VCC power only.
- Note 4.6** The nLPCPD pin may be tied high. The LPC interface will function properly if the nPCI_RESET signal follows the protocol defined for the nLRESET signal in the “Low Pin Count Interface Specification”.
- Note 4.7** This pin is input to VCC and VTR powered logic internal to the part.
- Note 4.8** The SYSOPT pin requires an external pulldown resistor to put the base IO address for configuration at 0x02E. An external pullup resistor is required to move the base IO address for configuration to 0x04E.

4.1 Buffer Name Description

Note: The buffer type values are specified at VCC=3.3V. Refer to the “Operational Description” section.

I	Input TTL Compatible.
IS	Input with 100mV Schmitt Trigger.
IS2	Input with 250mV Schmitt Trigger.
ICLK	Crystal Input
OCLK	Crystal Output
O8	Output, 8mA sink, 4mA source.
OD8	Open Drain Output, 8mA sink.
IO8	Input/Output, 8mA sink, 4mA source.
IS2OD12	Input with 250mV Schmitt Trigger/Output (Open Drain), 12mA sink.
O12	Output, 12mA sink, 6mA source.
OD12	Open Drain Output, 12mA sink.
OP14	Output, 14mA sink, 14mA source.
IOP14	Input/Output, 14mA sink, 14mA source. Backdrive protected.
PCI_I	Input. These pins meet the PCI 3.3V AC and DC Characteristics. (Note 4.9)
PCI_O	Output. These pins meet the PCI 3.3V AC and DC Characteristics. (Note 4.9)
PCI_IO	Input/Output. These pins meet the PCI 3.3V AC and DC Characteristics. (Note 4.9)
PCI_IOD	Input/Output (Open Drain). These pins meet the PCI 3.3V AC and DC Characteristics. (Note 4.9)
PCI_ICLK	Clock Input. These pins meet the PCI 3.3V AC and DC Characteristics and timing. (Note 4.10)

Note 4.9 See the “PCI Local Bus Specification,” Revision 2.1, Section 4.2.2.

Note 4.10 See the “PCI Local Bus Specification,” Revision 2.1, Section 4.2.2 and 4.2.3.

4.2 Pins That Require External Resistors

The following pins require external pull-up resistors:

- LAD[3:0]
- nLDRQ
- SER_IRQ
- nCLKRUN
- nIO_PME if used as Open Drain Output
- nALF if used as Open Drain Output
- nSTROBE if used as Open Drain Output
- nINIT if used as Open Drain Output
- nSLCTIN if used as Open Drain Output
- SMB_A0 – this pin has weak internal pull-down. External pull-up can be used to change the LSB of SMBus device address.
- SDAT
- SCLK
- nSMBINT
- SDAT_1
- SCLK_1
- SDAT_2
- SCLK_2

The following pin requires external pull-up/pull-down resistor:

- LGP47 (YSOPT) – pull-up or pull-down is required for YSOPT strap option to set system base IO address.
- GPIOs

Chapter 5 Block Diagram

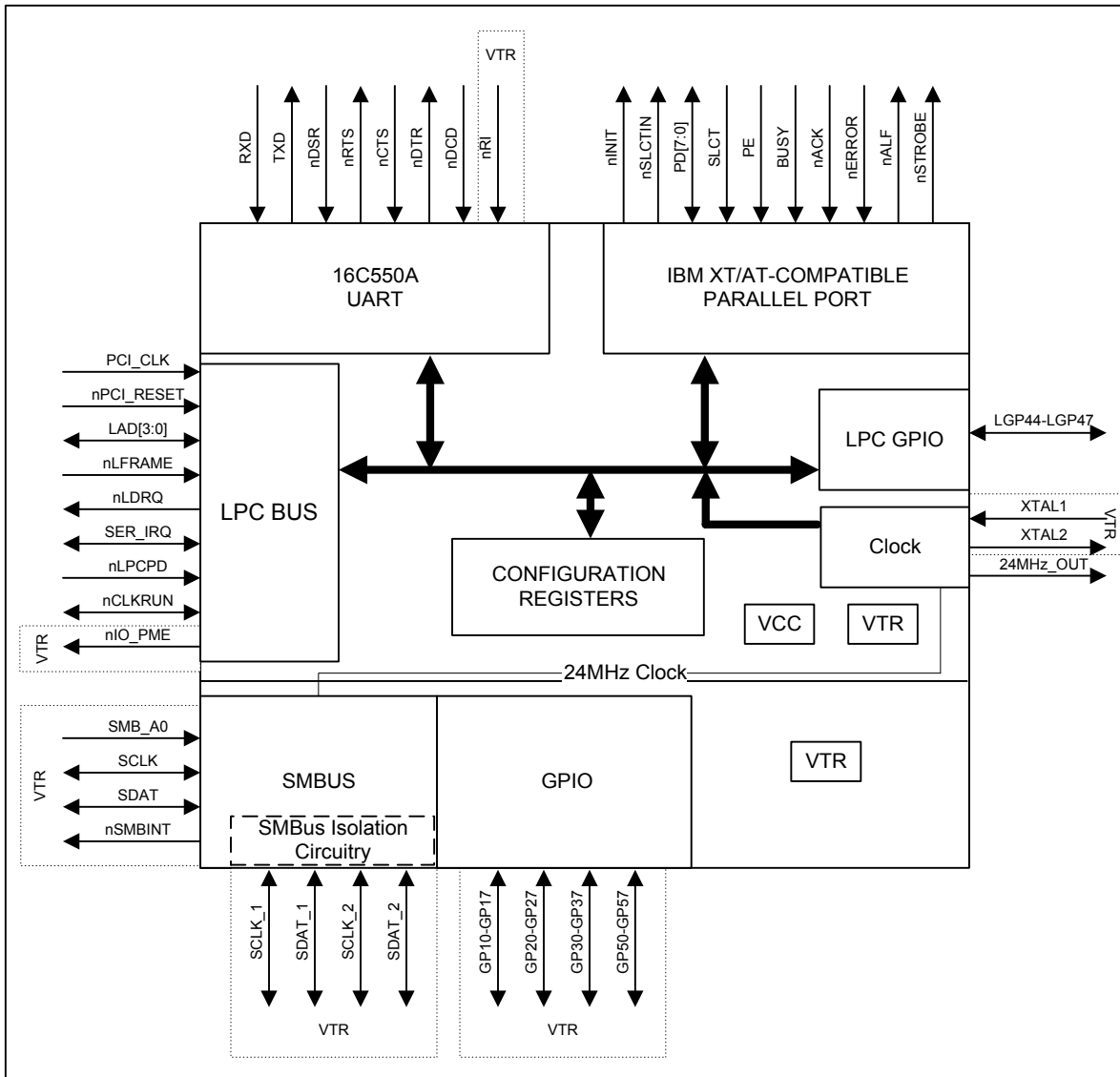

Figure 5.1 – LPC47N237 Block Diagram

Chapter 6 Power/Clock Functionality

The LPC47N237 has two power planes: VCC and VTR. It contains 24 MHz crystal pins and 24 MHz clock output.

6.1 3.3 Volt Operation / 5 Volt Tolerance

The LPC47N237 is a 3.3 Volt part. It is intended solely for 3.3V applications. Non-LPC bus pins are 5V tolerant; that is, the input voltage is 5.5V max, and the I/O buffer output pads are backdrive protected.

The LPC interface pins are 3.3 V only. These signals meet PCI DC specifications for 3.3V signaling. These pins are:

- LAD[3:0]
- nLFRAME
- nLDRQ
- nLPCPD

The input voltage for all other pins is 5.5V max. These pins include all non-LPC Bus pins and the following pins:

- nPCI_RESET
- PCI_CLK
- SER_IRQ
- nCLKRUN
- nIO_PME

6.2 VCC Power

The LPC47N237 is a 3.3 Volt part. The VCC supply is 3.3 Volts (nominal). See the Operational Description Section and the Maximum Current Values subsection.

6.3 VTR Power

The LPC47N237 requires a trickle supply (V_{TR}) to provide sleep current for the programmable wake-up events in the PME interface when V_{CC} is removed. The VTR supply is 3.3 Volts (nominal). See the Operational Description Section. The maximum VTR current that is required depends on the functions that are used in the part. See Trickle Power Functionality subsection and the Maximum Current Values subsection. If the LPC47N237 is not intended to provide wake-up capabilities on standby current, V_{TR} can be connected to V_{CC} . The V_{TR} pin generates a V_{TR} Power-on-Reset signal to initialize these components.

Note: If V_{TR} is to be used for programmable wake-up events when V_{CC} is removed, V_{TR} must be at its full minimum potential at least 10 μ s before V_{CC} begins a power-on cycle. When V_{TR} and V_{CC} are fully powered, the potential difference between the two supplies must not exceed 500mV.

6.3.1 Trickle Power Functionality

The following requirements apply to all I/O pins that are specified to be 5 volt tolerant.

- I/O buffers that are not wake-up compatible are powered by VCC. In the absence of VCC they are backdrive protected (they do not impose load on any VTR powered circuitry). These pins do not have input buffers into the wakeup logic that are powered by VTR, and are not used for wakeup.
- I/O buffers that are wake-up event compatible are powered by VTR. These pins have input buffers into the wakeup logic that are powered by VTR.
- I/O buffers that may be configured as either push-pull or open drain under VTR power (VCC=0), are powered by VTR. This means they will, at a minimum, source their specified current from VTR even when VCC is present.

The following list summarizes the blocks, registers and pins that are powered by VTR.

- Blocks and Pins in SIO Block
- PME interface block
- Runtime register block (includes PME and GP data registers)
- Pins for PME Wakeup:
 - nIO_PME
 - nRI
- XTAL1 and XTAL2 pins
- SMBus GPIO Block
 - SMBus Controller
 - GPIO Block
 - Pins
- GP10-GP30, GP50-GP57. These GPIOs can be used to detect an edge on the pin and can be driven under VTR power.
- SCLK, SDAT, SMB_A0, nSMBINT, SCLK_1, SDAT_1, SCLK_2, SDAT_2

6.4 24 MHz Crystal

The LPC47N237 utilizes 24 MHz crystal pins XTAL1 and XTAL2. The XTAL1 pin can also be used to as a single-ended clock source pin provided that XTAL2 is left unconnected. The 24 MHz clock is used to generate specific clock needed for various logic in the Super I/O Block. This clock also is also used for the SMBus GPIO Block. The XTAL1 and XTAL2 pins are powered by VTR and this clock source is available both when VCC is active and when the part is under VTR power only (VCC=0).

6.5 24 MHz Output

The 24MHz_OUT is a 24 MHz clock output pin and is powered by VCC. This clock in not available when VCC = 0.

6.6 Internal PWRGOOD

An internal PWRGOOD logical control is included to minimize the effects of pin-state uncertainty in the host interface as V_{CC} cycles on and off. When the internal PWRGOOD signal is “1” (active), V_{CC} > 2.3V (nominal), and the LPC47N237 host interface is active. When the internal PWRGOOD signal is “0”

(inactive), $V_{CC} \leq 2.3V$ (nominal), and the LPC47N237 host interface is inactive; that is, LPC bus reads and writes will not be decoded.

The LPC47N237 device VTR pins that are listed in the “Trickle Power Functionality” section will remain active when the internal PWRGOOD signal has gone inactive, provided V_{TR} is powered.

6.7 Maximum Current Values

See the “Operational Description” section for the maximum current values.

The maximum VTR current, I_{TR} , is given with all outputs open (not loaded), and all inputs transitioning from/to 0V to/from 3.3V. The total maximum current for the part is the unloaded value PLUS the maximum current sourced by the pin that is driven by VTR. The pins that are powered by VTR are listed in the “Trickle Power Functionality” section.

The maximum VCC current, I_{CC} , is given with all outputs open (not loaded) and all inputs transitioning from/to 0V to/from 3.3V.

6.8 Power Management Events (PME/SCI)

The LPC47N237 offers support for Power Management Events (PMEs), also referred to as System Control Interrupt (SCI) events. The terms PME and SCI are used synonymously throughout this document to refer to the indication of an event to the chipset via the assertion of the nIO_PME output signal. See the “PME Support” section.

Chapter 7 Functional Description

The following sections describe the functional blocks located in the LPC47N237 (see Figure 5.1). All the functional blocks are dedicated to the Super I/O portion of the chip, except the SMBus GPIO Block. The SMBus GPIO Block is maintained separately from the Super I/O components and is defined in the “SMBus GPIO Block” section. The various Super I/O components are described in the following sections and their registers are implemented as typical Plug-and-Play components (see “Configuration” section). The SMBus GPIO Block registers are accessible via the SMBus slave address and are defined in the “SMBus GPIO Register Map” section. The Super I/O components is powered by VCC and VTR (where wakeup functionality is required). The SMBus GPIO Block is powered by VTR.

It should be noted that there are two main interfaces used to access the components of this chip. The LPC interface is used to access the Super I/O registers and the SMBus is used to access the SMBus GPIO registers.

7.1 Super I/O Registers

The address map, shown below in Table 7.1, shows the addresses of the different blocks of the Super I/O immediately after power up. The base addresses of the Serial Port, and Parallel Port, Runtime Register Block and Configuration Register block can be moved via the configuration registers. Some addresses are used to access more than one register.

7.2 Host Processor Communication

The host processor communicates with the LPC47N237 through a series of read/write registers via the LPC interface. The port addresses for these registers are shown in Table 7.1. Register access is accomplished through I/O cycles or DMA transfers. All registers are 8 bits wide.

Table 7.1 - Super I/O Block Addresses

ADDRESS	BLOCK NAME
Base+(0-7)	Serial Port
Base+(0-3)	Parallel Port
Base+(0-7)	SPP
Base+(0-7)	EPP
Base+(0-3), +(400-402)	ECP
Base+(0-7), +(400-402)	ECP+EPP+SPP
Base + (0-3)	Runtime Registers
Base + (0-1)	Configuration

Note: Refer to the configuration registers description for setting the base addresses.

7.3 LPC Interface

The following sub-sections specify the implementation of the LPC bus.

7.3.1 LPC Interface Signal Definition

The signals required for the LPC bus interface are described in the table below. LPC bus signals use PCI 33MHz electrical signal characteristics.

SIGNAL NAME	TYPE	DESCRIPTION
LAD[3:0]	I/O	LPC address/data bus. Multiplexed command, address and data bus.
nLFRAME	Input	Frame signal. Indicates start of new cycle and termination of broken cycle
nPCI_RESET	Input	PCI Reset. Used as LPC Interface Reset.
nLDRQ	Output	Encoded DMA/Bus Master request for the LPC interface.
nIO_PME	OD	Power Mgt Event signal. Allows the LPC47N237 to request wakeup.
nLPCPD	Input	Powerdown Signal. Indicates that the LPC47N237 should prepare for power to be shut on the LPC interface.
SER_IRQ	I/O	Serial IRQ.
PCI_CLK	Input	PCI Clock.
nCLKRUN	I/OD	Clock Run. Allows the LPC47N237 to request the stopped PCI_CLK be started.

LPC Cycles

The following cycle types are supported by the LPC protocol.

CYCLE TYPE	TRANSFER SIZE
I/O Write	1 Byte
I/O Read	1 Byte
DMA Write	1 Byte
DMA Read	1 Byte

The LPC47N237 ignores cycles that it does not support.

Field Definitions

The data transfers are based on specific fields that are used in various combinations, depending on the cycle type. These fields are driven onto the LAD[3:0] signal lines to communicate address, control and data information over the LPC bus between the host and the LPC47N237. See the *Low Pin Count (LPC) Interface Specification* Revision 1.0 from Intel, Section 4.2 for definition of these fields.

nLFRAME Usage

nLFRAME is used by the host to indicate the start of cycles and the termination of cycles due to an abort or time-out condition. This signal is to be used by the LPC47N237 to know when to monitor the bus for a cycle.

This signal is used as a general notification that the LAD[3:0] lines contain information relative to the start or stop of a cycle, and that the LPC47N237 monitors the bus to determine whether the cycle is intended for it. The use of nLFRAME allows the LPC47N237 to enter a lower power state internally. There is no need for the LPC47N237 to monitor the bus when it is inactive, so it can decouple its state machines from the bus, and internally gate its clocks.

When the LPC47N237 samples nLFRAME active, it immediately stops driving the LAD[3:0] signal lines on the next clock and monitor the bus for new cycle information.

The nLFRAME signal functions as described in the Low Pin Count (LPC) Interface Specification Revision 1.0.

I/O Read and Write Cycles

The LPC47N237 is the target for I/O cycles. I/O cycles are initiated by the host for register or FIFO accesses, and will generally have minimal Sync times. The minimum number of wait-states between bytes is 1. EPP cycles will depend on the speed of the external device, and may have much longer Sync times.

Data transfers are assumed to be exactly 1-byte. If the CPU requested a 16 or 32-bit transfer, the host will break it up into 8-bit transfers.

See the *Low Pin Count (LPC) Interface Specification Reference*, Section 5.2, for the sequence of cycles for the I/O Read and Write cycles.

DMA Read and Write Cycles

DMA read cycles involve the transfer of data from the host (main memory) to the LPC47N237. DMA write cycles involve the transfer of data from the LPC47N237 to the host (main memory). Data will be coming from or going to a FIFO and will have minimal Sync times. Data transfers to/from the LPC47N237 are 1 byte.

See the *Low Pin Count (LPC) Interface Specification Reference*, Section 6.4, for the field definitions and the sequence of the DMA Read and Write cycles.

DMA Protocol

DMA on the LPC bus is handled through the use of the nLDRQ lines from the LPC47N237 and special encodings on LAD[3:0] from the host.

The DMA mechanism for the LPC bus is described in the Low Pin Count (LPC) Specification Revision 1.0.

7.3.2 Power Management

CLOCKRUN Protocol

See the *Low Pin Count (LPC) Interface Specification Reference*, Section 8.1 and "PCI CLKRUN Support" section.

LPCPD Protocol

The LPC47N237 will function properly if the nLPCPD signal goes active and then inactive again without nPCI_RESET becoming active. This is a requirement for notebook power management functions.

Although the LPC Bus spec 1.0 section 8.2 states, "After nLPCPD goes back inactive, the LPC I/F will always be reset using LRST#", this statement does not apply for mobile systems. LRST# (nPCI_RESET) will not occur if the LPC Bus power was not removed. For example, when exiting a "light" sleep state (ACPI S1, APM POS), LRST# (nPCI_RESET) will not occur. When exiting a "deeper" sleep state (ACPI S3-S5, APM STR, STD, soft-off), LRST# (nPCI_RESET) will occur.

The nLPCPD pin is implemented as a "local" powergood for the LPC bus in the LPC47N237. It is not used as a global powergood for the chip. It is used to reset the LPC block and hold it in reset.

An internal powergood is implemented in LPC47N237 to minimize power dissipation in the entire chip.

Prior to going to a low-power state, the system will assert the nLPCPD signal. It will go active at least 30 microseconds prior to the LCLK# (PCI_CLK) signal stopping low and power being shut to the other LPC I/F signals.

Upon recognizing nLPCPD active, the LPC47N237 will drive the nLDRQ signal low or tri-state, and do so until nLPCPD goes back active.

Upon recognizing nLPCPD inactive, the LPC47N237 will drive its nLDRQ signal high.

See the *Low Pin Count (LPC) Interface Specification* Reference, Section 8.2.

SYNC Protocol

See the *Low Pin Count (LPC) Interface Specification* Reference, Section 4.2.1.8 for a table of valid SYNC values.

Typical Usage

The SYNC pattern is used to add wait states. For read cycles, the LPC47N237 immediately drives the SYNC pattern upon recognizing the cycle. The host immediately drives the sync pattern for write cycles. If the LPC47N237 needs to assert wait states, it does so by driving 0101 or 0110 on LAD[3:0] until it is ready, at which point it will drive 0000 or 1001. The LPC47N237 will choose to assert 0101 or 0110, but not switch between the two patterns.

The data (or wait state SYNC) will immediately follow the 0000 or 1001 value.

The SYNC value of 0101 is intended to be used for normal wait states, wherein the cycle will complete within a few clocks. The LPC47N237 uses a SYNC of 0101 for all wait states in a DMA transfer.

The SYNC value of 0110 is intended to be used where the number of wait states is large. This is provided for EPP cycles, where the number of wait states could be quite large (>1 microsecond). However, the LPC47N237 uses a SYNC of 0110 for all wait states in an I/O transfer.

The SYNC value is driven within 3 clocks.

SYNC Timeout

The SYNC value is driven within 3 clocks. If the host observes 3 consecutive clocks without a valid SYNC pattern, it will abort the cycle.

The LPC47N237 does not assume any particular timeout. When the host is driving SYNC, it may have to insert a very large number of wait states, depending on PCI latencies and retries.

SYNC Patterns and Maximum Number of SYNCs

If the SYNC pattern is 0101, then the host assumes that the maximum number of SYNCs is 8.

If the SYNC pattern is 0110, then no maximum number of SYNCs is assumed. The LPC47N237 has protection mechanisms to complete the cycle. This is used for EPP data transfers and will utilize the same timeout protection that is in EPP.

SYNC Error Indication

The LPC47N237 reports errors via the LAD[3:0] = 1010 SYNC encoding.

If the host was reading data from the LPC47N237, data will still be transferred in the next two nibbles. This data may be invalid, but it will be transferred by the LPC47N237. If the host was writing data to the LPC47N237, the data had already been transferred.

In the case of multiple byte cycles, such as DMA cycles, an error SYNC terminates the cycle. Therefore, if the host is transferring 4 bytes from a device, if the device returns the error SYNC in the first byte, the other three bytes will not be transferred.

I/O and DMA START Fields

I/O and DMA cycles use a START field of 0000.

Reset Policy

The following rules govern the reset policy:

1. When nPCI_RESET goes inactive (high), the clock is assumed to have been running for 100usec prior to the removal of the reset signal, so that everything is stable. This is the same reset active time after clock is stable that is used for the PCI bus.
2. When nPCI_RESET goes active (low):
 - a) the host drives the nLFRAME signal high, tristates the LAD[3:0] signals, and ignores the nLDRQ signal.
 - b) the LPC47N237 ignores nLFRAME, tristate the LAD[3:0] pins and drive the nLDRQ signal inactive (high).

7.3.3 LPC Transfers

Wait State Requirements

I/O Transfers

The LPC47N237 inserts three wait states for an I/O read and two wait states for an I/O write cycle. A SYNC of 0110 is used for all I/O transfers. The exception to this is for transfers where IOCHRDY would be deasserted in an ISA transfer (i.e., EPP or IrCC transfers) in which case the sync pattern of 0110 is used and a large number of syncs may be inserted (up to 330 which corresponds to a timeout of 10us).

DMA Transfers

The LPC47N237 inserts three wait states for a DMA read and four wait states for a DMA write cycle. A SYNC of 0101 is used for all DMA transfers.

See the example timing for the LPC cycles in the “Timing Diagrams” section.

Chapter 8 Serial Port (UART)

The LPC47N237 incorporates a full function UART. They are compatible with the 16450, the 16450 ACE registers and the 16C550A. The UART perform serial-to-parallel conversion on received characters and parallel-to-serial conversion on transmit characters. The data rates are independently programmable from 460.8K baud down to 50 baud. The character options are programmable for 1 start; 1, 1.5 or 2 stop bits; even, odd, sticky or no parity; and prioritized interrupts. The UART contains a programmable baud rate generator that is capable of dividing the input clock or crystal by a number from 1 to 65535. The UART is also capable of supporting the MIDI data rate. Refer to the Configuration Registers for information on disabling, power down and changing the base address of the UARTs. The interrupt from a UART is enabled by programming OUT2 of that UART to a logic "1". OUT2 being a logic "0" disables that UART's interrupt.

8.1 Register Description

Addressing of the accessible registers of the Serial Port is shown below. The base addresses of the serial ports are defined by the configuration registers (see Configuration section). The Serial Port registers are located at sequentially increasing addresses above these base addresses. The LPC47N237 serial port register set is described below.

Table 8.1 - Addressing the Serial Port

DLAB (NOTE 8.1)	A2	A1	A0	REGISTER NAME
0	0	0	0	Receive Buffer (read)
0	0	0	0	Transmit Buffer (write)
0	0	0	1	Interrupt Enable (read/write)
X	0	1	0	Interrupt Identification (read)
X	0	1	0	FIFO Control (write)
X	0	1	1	Line Control (read/write)
X	1	0	0	Modem Control (read/write)
X	1	0	1	Line Status (read/write)
X	1	1	0	Modem Status (read/write)
X	1	1	1	Scratchpad (read/write)
1	0	0	0	Divisor LSB (read/write)
1	0	0	1	Divisor MSB (read/write)

Note 8.1 DLAB is Bit 7 of the Line Control Register

The following section describes the operation of the registers.

8.1.1 Receive Buffer Register (RB)

Address Offset = 0H, DLAB = 0, READ ONLY

This register holds the received incoming data byte. Bit 0 is the least significant bit, which is transmitted and received first. Received data is double buffered; this uses an additional shift register to receive the serial data stream and convert it to a parallel 8 bit word which is transferred to the Receive Buffer register. The shift register is not accessible.

8.1.2 Transmit Buffer Register (TB)

Address Offset = 0H, DLAB = 0, WRITE ONLY

This register contains the data byte to be transmitted. The transmit buffer is double buffered, utilizing an additional shift register (not accessible) to convert the 8 bit data word to a serial format. This shift register is loaded from the Transmit Buffer when the transmission of the previous byte is complete.

8.1.3 Interrupt Enable Register (IER)

Address Offset = 1H, DLAB = 0, READ/WRITE

The lower four bits of this register control the enables of the five interrupt sources of the Serial Port interrupt. It is possible to totally disable the interrupt system by resetting bits 0 through 3 of this register. Similarly, setting the appropriate bits of this register to a high, selected interrupts can be enabled. Disabling the interrupt system inhibits the Interrupt Identification Register and disables any Serial Port interrupt out of the LPC47N237. All other system functions operate in their normal manner, including the Line Status and MODEM Status Registers. The contents of the Interrupt Enable Register are described below.

Bit 0

This bit enables the Received Data Available Interrupt (and timeout interrupts in the FIFO mode) when set to logic "1".

Bit 1

This bit enables the Transmitter Holding Register Empty Interrupt when set to logic "1".

Bit 2

This bit enables the Received Line Status Interrupt when set to logic "1". The error sources causing the interrupt are Overrun, Parity, Framing and Break. The Line Status Register must be read to determine the source.

Bit 3

This bit enables the MODEM Status Interrupt when set to logic "1". This is caused when one of the Modem Status Register bits changes state.

Bits 4 through 7

These bits are always logic "0".

8.1.4 FIFO Control Register (FCR)

Address Offset = 2H, DLAB = X, WRITE

This is a write only register at the same location as the IIR. This register is used to enable and clear the FIFOs, set the RCVR FIFO trigger level. Note: DMA is not supported. The UART FCR is shadowed in the UART FIFO Control Shadow Register (CR15). See the Configuration section for description on these registers.

Bit 0

Setting this bit to a logic "1" enables both the XMIT and RCVR FIFOs. Clearing this bit to a logic "0" disables both the XMIT and RCVR FIFOs and clears all bytes from both FIFOs. When changing from FIFO Mode to non-FIFO (16450) mode, data is automatically cleared from the FIFOs. This bit must be a 1 when other bits in this register are written to or they will not be properly programmed.

Bit 1

Setting this bit to a logic "1" clears all bytes in the RCVR FIFO and resets its counter logic to 0. The shift register is not cleared. This bit is self-clearing.

Bit 2

Setting this bit to a logic "1" clears all bytes in the XMIT FIFO and resets its counter logic to 0. The shift register is not cleared. This bit is self-clearing.

Bit 3

Writing to this bit has no effect on the operation of the UART. DMA modes are not supported in this chip.

Bit 4,5

Reserved

Bit 6,7

These bits are used to set the trigger level for the RCVR FIFO interrupt.

BIT 7	BIT 6	RCVR FIFO TRIGGER LEVEL (BYTES)
0	0	1
0	1	4
1	0	8
1	1	14

8.1.5 Interrupt Identification Register (IIR)

Address Offset = 2H, DLAB = X, READ

By accessing this register, the host CPU can determine the highest priority interrupt and its source. Four levels of priority interrupt exist. They are in descending order of priority:

1. Receiver Line Status (highest priority)
2. Received Data Ready
3. Transmitter Holding Register Empty
4. MODEM Status (lowest priority)

Information indicating that a prioritized interrupt is pending and the source of that interrupt is stored in the Interrupt Identification Register (refer to Interrupt Control Table). When the CPU accesses the IIR, the Serial Port freezes all interrupts and indicates the highest priority pending interrupt to the CPU. During this

CPU access, even if the Serial Port records new interrupts, the current indication does not change until access is completed. The contents of the IIR are described below.

Bit 0

This bit can be used in either a hardwired prioritized or polled environment to indicate whether an interrupt is pending. When bit 0 is a logic "0", an interrupt is pending and the contents of the IIR may be used as a pointer to the appropriate internal service routine. When bit 0 is a logic "1", no interrupt is pending.

Bits 1 and 2

These two bits of the IIR are used to identify the highest priority interrupt pending as indicated by the Interrupt Control Table.

Bit 3

In non-FIFO mode, this bit is a logic "0". In FIFO mode this bit is set along with bit 2 when a timeout interrupt is pending.

Bits 4 and 5

These bits of the IIR are always logic "0".

Bits 6 and 7

These two bits are set when the FIFO CONTROL Register bit 0 equals 1.

Table 8.2 – UART Interrupt Control Table

FIFO MODE ONLY	INTERRUPT IDENTIFICATION REGISTER			INTERRUPT SET AND RESET FUNCTIONS				
	BIT 3	BIT 2	BIT 1	BIT 0	PRIORITY LEVEL	INTERRUPT TYPE	INTERRUPT SOURCE	INTERRUPT RESET CONTROL
0	0	0	0	1	-	None	None	-
0	1	1	1	0	Highest	Receiver Line Status	Overrun Error, Parity Error, Framing Error or Break Interrupt	Reading the Line Status Register
0	1	0	0	0	Second	Received Data Available	Receiver Data Available	Read Receiver Buffer or the FIFO drops below the trigger level.
1	1	0	0	0	Second	Character Timeout Indication	No Characters Have Been Removed From or Input to the RCVR FIFO during the last 4 Char times and there is at least 1 char in it during this time	Reading the Receiver Buffer Register

FIFO MODE ONLY	INTERRUPT IDENTIFICATION REGISTER			INTERRUPT SET AND RESET FUNCTIONS			
	BIT 3	BIT 2	BIT 1	BIT 0	PRIORITY LEVEL	INTERRUPT TYPE	INTERRUPT SOURCE
0	0	1	0	Third	Transmitter Holding Register Empty	Transmitter Holding Register Empty	Reading the IIR Register (if Source of Interrupt) or Writing the Transmitter Holding Register
0	0	0	0	Fourth	MODEM Status	Clear to Send or Data Set Ready or Ring Indicator or Data Carrier Detect	Reading the MODEM Status Register

8.1.6 Line Control Register (LCR)

Address Offset = 3H, DLAB = 0, READ/WRITE

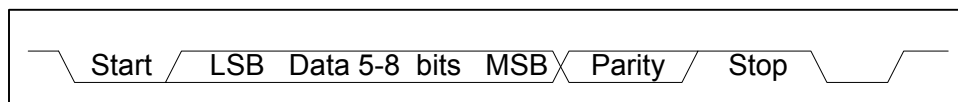

Figure 8.1 - Serial Data

This register contains the format information of the serial line. The bit definitions are:

Bits 0 and 1

These two bits specify the number of bits in each transmitted or received serial character. The encoding of bits 0 and 1 is as follows:

The Start, Stop and Parity bits are not included in the word length.

BIT 1	BIT 0	WORD LENGTH
0	0	5 Bits
0	1	6 Bits
1	0	7 Bits
1	1	8 Bits

Bit 2

This bit specifies the number of stop bits in each transmitted or received serial character. The following table summarizes the information.

BIT 2	WORD LENGTH	NUMBER OF STOP BITS
0	--	1
1	5 bits	1.5
1	6 bits	2
1	7 bits	2
1	8 bits	2

Note: The receiver will ignore all stop bits beyond the first, regardless of the number used in transmitting.

Bit 3

Parity Enable bit. When bit 3 is a logic "1", a parity bit is generated (transmit data) or checked (receive data) between the last data word bit and the first stop bit of the serial data. (The parity bit is used to generate an even or odd number of 1s when the data word bits and the parity bit are summed).

Bit 4

Even Parity Select bit. When bit 3 is a logic "1" and bit 4 is a logic "0", an odd number of logic "1"s is transmitted or checked in the data word bits and the parity bit. When bit 3 is a logic "1" and bit 4 is a logic "1" an even number of bits is transmitted and checked.

Bit 5

Stick Parity bit. When parity is enabled it is used in conjunction with bit 4 to select Mark or Space Parity. When LCR bits 3, 4 and 5 are 1 the Parity bit is transmitted and checked as 0 (Space Parity). If bits 3 and 5 are 1 and bit 4 is a 0, then the Parity bit is transmitted and checked as 1 (Mark Parity). If bit 5 is 0 Stick Parity is disabled.

Bit 6

Set Break Control bit. When bit 6 is a logic "1", the transmit data output (TXD) is forced to the Spacing or logic "0" state and remains there (until reset by a low level bit 6) regardless of other transmitter activity. This feature enables the Serial Port to alert a terminal in a communications system.

Bit 7

Divisor Latch Access bit (DLAB). It must be set high (logic "1") to access the Divisor Latches of the Baud Rate Generator during read or write operations. It must be set low (logic "0") to access the Receiver Buffer Register, the Transmitter Holding Register, or the Interrupt Enable Register.

8.1.7 Modem Control Register (MCR)

Address Offset = 4H, DLAB = X, READ/WRITE

This 8 bit register controls the interface with the MODEM or data set (or device emulating a MODEM). The contents of the MODEM control register are described below.

Bit 0

This bit controls the Data Terminal Ready (nDTR) output. When bit 0 is set to a logic "1", the nDTR output is forced to a logic "0". When bit 0 is a logic "0", the nDTR output is forced to a logic "1".

Bit 1

This bit controls the Request To Send (nRTS) output. Bit 1 affects the nRTS output in a manner identical to that described above for bit 0.

Bit 2

This bit controls the Output 1 (OUT1) bit. This bit does not have an output pin and can only be read or written by the CPU.

Bit 3

Output 2 (OUT2). This bit is used to enable an UART interrupt. When OUT2 is a logic "0", the serial port interrupt output is forced to a high impedance state - disabled. When OUT2 is a logic "1", the serial port interrupt outputs are enabled.

Bit 4

This bit provides the loopback feature for diagnostic testing of the Serial Port. When bit 4 is set to logic "1", the following occur:

1. The TXD is set to the Marking State(logic "1").
2. The receiver Serial Input (RXD) is disconnected.
3. The output of the Transmitter Shift Register is "looped back" into the Receiver Shift Register input.
4. All MODEM Control inputs (nCTS, nDSR, nRI and nDCD) are disconnected.
5. The four MODEM Control outputs (nDTR, nRTS, OUT1 and OUT2) are internally connected to the four MODEM Control inputs (nDSR, nCTS, RI, DCD).
6. The Modem Control output pins are forced inactive high.
7. Data that is transmitted is immediately received.

This feature allows the processor to verify the transmit and receive data paths of the Serial Port. In the diagnostic mode, the receiver and the transmitter interrupts are fully operational. The MODEM Control Interrupts are also operational but the interrupts' sources are now the lower four bits of the MODEM Control Register instead of the MODEM Control inputs. The interrupts are still controlled by the Interrupt Enable Register.

Bits 5 through 7

These bits are permanently set to logic zero.

8.1.8 Line Status Register (LSR)

Address Offset = 5H, DLAB = X, READ/WRITE

Bit 0

Data Ready (DR). It is set to a logic "1" whenever a complete incoming character has been received and transferred into the Receiver Buffer Register or the FIFO. Bit 0 is reset to a logic "0" by reading all of the data in the Receive Buffer Register or the FIFO.

Bit 1

Overrun Error (OE). Bit 1 indicates that data in the Receiver Buffer Register was not read before the next character was transferred into the register, thereby destroying the previous character. In FIFO mode, an

overrun error will occur only when the FIFO is full and the next character has been completely received in the shift register, the character in the shift register is overwritten but not transferred to the FIFO. The OE indicator is set to a logic "1" immediately upon detection of an overrun condition, and reset whenever the Line Status Register is read.

Bit 2

Parity Error (PE). Bit 2 indicates that the received data character does not have the correct even or odd parity, as selected by the even parity select bit. The PE is set to a logic "1" upon detection of a parity error and is reset to a logic "0" whenever the Line Status Register is read. In the FIFO mode this error is associated with the particular character in the FIFO it applies to. This error is indicated when the associated character is at the top of the FIFO.

Bit 3

Framing Error (FE). Bit 3 indicates that the received character did not have a valid stop bit. Bit 3 is set to a logic "1" whenever the stop bit following the last data bit or parity bit is detected as a zero bit (Spacing level). The FE is reset to a logic "0" whenever the Line Status Register is read. In the FIFO mode this error is associated with the particular character in the FIFO it applies to. This error is indicated when the associated character is at the top of the FIFO. The Serial Port will try to resynchronize after a framing error. To do this, it assumes that the framing error was due to the next start bit, so it samples this 'start' bit twice and then takes in the 'data'.

Bit 4

Break Interrupt (BI). Bit 4 is set to a logic "1" whenever the received data input is held in the Spacing state (logic "0") for longer than a full word transmission time (that is, the total time of the start bit + data bits + parity bits + stop bits). The BI is reset after the CPU reads the contents of the Line Status Register. In the FIFO mode this error is associated with the particular character in the FIFO it applies to. This error is indicated when the associated character is at the top of the FIFO. When break occurs only one zero character is loaded into the FIFO. Restarting after a break is received, requires the serial data (RXD) to be logic "1" for at least 1/2 bit time.

Note: Bits 1 through 4 are the error conditions that produce a Receiver Line Status Interrupt whenever any of the corresponding conditions are detected and the interrupt is enabled.

Bit 5

Transmitter Holding Register Empty (THRE). Bit 5 indicates that the Serial Port is ready to accept a new character for transmission. In addition, this bit causes the Serial Port to issue an interrupt when the Transmitter Holding Register interrupt enable is set high. The THRE bit is set to a logic "1" when a character is transferred from the Transmitter Holding Register into the Transmitter Shift Register. The bit is reset to logic "0" whenever the CPU loads the Transmitter Holding Register. In the FIFO mode this bit is set when the XMIT FIFO is empty, it is cleared when at least 1 byte is written to the XMIT FIFO. Bit 5 is a read only bit.

Bit 6

Transmitter Empty (TEMT). Bit 6 is set to a logic "1" whenever the Transmitter Holding Register (THR) and Transmitter Shift Register (TSR) are both empty. It is reset to logic "0" whenever either the THR or TSR contains a data character. Bit 6 is a read only bit. In the FIFO mode this bit is set whenever the THR and TSR are both empty.

Bit 7

This bit is permanently set to logic "0" in the 450 mode. In the FIFO mode, this bit is set to a logic "1" when there is at least one parity error, framing error or break indication in the FIFO. This bit is cleared when the LSR is read if there are no subsequent errors in the FIFO.

8.1.9 Modem Status Register (MSR)

Address Offset = 6H, DLAB = X, READ/WRITE

This 8 bit register provides the current state of the control lines from the MODEM (or peripheral device). In addition to this current state information, four bits of the MODEM Status Register (MSR) provide change information. These bits are set to logic "1" whenever a control input from the MODEM changes state. They are reset to logic "0" whenever the MODEM Status Register is read.

Bit 0

Delta Clear To Send (DCTS). Bit 0 indicates that the nCTS input to the chip has changed state since the last time the MSR was read.

Bit 1

Delta Data Set Ready (DDSR). Bit 1 indicates that the nDSR input has changed state since the last time the MSR was read.

Bit 2

Trailing Edge of Ring Indicator (TERI). Bit 2 indicates that the nRI input has changed from logic "0" to logic "1".

Bit 3

Delta Data Carrier Detect (DDCD). Bit 3 indicates that the nDCD input to the chip has changed state.

Note: Whenever bit 0, 1, 2, or 3 is set to a logic "1", a MODEM Status Interrupt is generated.

Bit 4

This bit is the complement of the Clear To Send (nCTS) input. If bit 4 of the MCR is set to logic "1", this bit is equivalent to nRTS in the MCR.

Bit 5

This bit is the complement of the Data Set Ready (nDSR) input. If bit 4 of the MCR is set to logic "1", this bit is equivalent to DTR in the MCR.

Bit 6

This bit is the complement of the Ring Indicator (nRI) input. If bit 4 of the MCR is set to logic "1", this bit is equivalent to OUT1 in the MCR.

Bit 7

This bit is the complement of the Data Carrier

Detect (nDCD) input. If bit 4 of the MCR is set to logic "1", this bit is equivalent to OUT2 in the MCR.

8.1.10 Scratchpad Register (SCR)

Address Offset =7H, DLAB =X, READ/WRITE

This 8 bit read/write register has no effect on the operation of the Serial Port. It is intended as a scratchpad register to be used by the programmer to hold data temporarily.

8.2 Programmable Baud Rate Generator (AND Divisor Latches DLH, DLL)

The Serial Port contains a programmable Baud Rate Generator that is capable of dividing the internal PLL clock by any divisor from 1 to 65535. The internal PLL clock is divided down to generate a 1.8462MHz frequency for Baud Rates less than 38.4k, a 1.8432MHz frequency for 115.2k, a 3.6864MHz frequency for 230.4k and a 7.3728MHz frequency for 460.8k. This output frequency of the Baud Rate Generator is 16x the Baud rate. Two 8 bit latches store the divisor in 16 bit binary format. These Divisor Latches must be loaded during initialization in order to insure desired operation of the Baud Rate Generator. Upon loading either of the Divisor Latches, a 16 bit Baud counter is immediately loaded. This prevents long counts on initial load. If a 0 is loaded into the BRG registers the output divides the clock by the number 3. If a 1 is loaded the output is the inverse of the input oscillator. If a two is loaded the output is a divide by 2 signal with a 50% duty cycle. If a 3 or greater is loaded the output is low for 2 bits and high for the remainder of the count. The input clock to the BRG is a 1.8462 MHz clock.

Table 8.3 shows the baud rates possible.

8.3 Effect Of The Reset on Register File

The Reset Function Table (Table 8.4) details the effect of the Reset input on each of the registers of the Serial Port.

8.4 FIFO Interrupt Mode Operation

When the RCVR FIFO and receiver interrupts are enabled (FCR bit 0 = "1", IER bit 0 = "1"), RCVR interrupts occur as follows:

1. The receive data available interrupt will be issued when the FIFO has reached its programmed trigger level; it is cleared as soon as the FIFO drops below its programmed trigger level.
2. The IIR receive data available indication also occurs when the FIFO trigger level is reached. It is cleared when the FIFO drops below the trigger level.
3. The receiver line status interrupt (IIR=06H), has higher priority than the received data available (IIR=04H) interrupt.
4. The data ready bit (LSR bit 0) is set as soon as a character is transferred from the shift register to the RCVR FIFO. It is reset when the FIFO is empty.

When RCVR FIFO and receiver interrupts are enabled, RCVR FIFO timeout interrupts occur as follows:

1. A FIFO timeout interrupt occurs if all the following conditions exist:
 - At least one character is in the FIFO.
 - The most recent serial character received was longer than 4 continuous character times ago. (If 2 stop bits are programmed, the second one is included in this time delay).
 - The most recent CPU read of the FIFO was longer than 4 continuous character times ago.

This will cause a maximum character received to interrupt issued delay of 160 msec at 300 BAUD with a 12 bit character.

2. Character times are calculated by using the RCLK input for a clock signal (this makes the delay proportional to the baudrate).
3. When a timeout interrupt has occurred it is cleared and the timer reset when the CPU reads one character from the RCVR FIFO.
4. When a timeout interrupt has not occurred the timeout timer is reset after a new character is received or after the CPU reads the RCVR FIFO.

When the XMIT FIFO and transmitter interrupts are enabled (FCR bit 0 = "1", IER bit 1 = "1"), XMIT interrupts occur as follows:

1. The transmitter holding register interrupt (02H) occurs when the XMIT FIFO is empty; it is cleared as soon as the transmitter holding register is written to (1 of 16 characters may be written to the XMIT FIFO while servicing this interrupt) or the IIR is read.
2. The transmitter FIFO empty indications will be delayed 1 character time minus the last stop bit time whenever the following occurs: THRE=1 and there have not been at least two bytes at the same time in the transmitter FIFO since the last THRE=1. The transmitter interrupt after changing FCR0 will be immediate, if it is enabled.

Character timeout and RCVR FIFO trigger level interrupts have the same priority as the current received data available interrupt; XMIT FIFO empty has the same priority as the current transmitter holding register empty interrupt.

8.5 FIFO Polled Mode Operation

With FCR bit 0 = "1" resetting IER bits 0, 1, 2 or 3 or all to zero puts the UART in the FIFO Polled Mode of operation. Since the RCVR and XMITTER are controlled separately, either one or both can be in the polled mode of operation. In this mode, the user's program will check RCVR and XMITTER status via the LSR. LSR definitions for the FIFO Polled Mode are as follows:

- Bit 0=1 as long as there is one byte in the RCVR FIFO.
- Bits 1 to 4 specify which error(s) have occurred. Character error status is handled the same way as when in the interrupt mode, the IIR is not affected since EIR bit 2=0.
- Bit 5 indicates when the XMIT FIFO is empty.
- Bit 6 indicates that both the XMIT FIFO and shift register are empty.
- Bit 7 indicates whether there are any errors in the RCVR FIFO.

There is no trigger level reached or timeout condition indicated in the FIFO Polled Mode, however, the RCVR and XMIT FIFOs are still fully capable of holding characters.

Table 8.3 – UART Baud Rates

DESIRED BAUD RATE	DIVISOR USED TO GENERATE 16X CLOCK	PERCENT ERROR DIFFERENCE BETWEEN DESIRED AND ACTUAL (NOTE 8.2)	HIGH SPEED BIT (NOTE 8.3)
50	2304	0.001	X
75	1536	-	X
110	1047	-	X
134.5	857	0.004	X
150	768	-	X
300	384	-	X
600	192	-	X

DESIRED BAUD RATE	DIVISOR USED TO GENERATE 16X CLOCK	PERCENT ERROR DIFFERENCE BETWEEN DESIRED AND ACTUAL (NOTE 8.2)	HIGH SPEED BIT (NOTE 8.3)
1200	96	-	X
1800	64	-	X
2000	58	0.005	X
2400	48	-	X
3600	32	-	X
4800	24	-	X
7200	16	-	X
9600	12	-	X
19200	6	-	X
38400	3	0.030	X
57600	2	0.16	X
115200	1	0.16	X
230400	32770	0.16	1
460800	32769	0.16	1

Note 8.2 The percentage error for all baud rates, except where indicated otherwise, is 0.2%.

Note 8.3 The High Speed bit is located in the Device Configuration Space.

Table 8.4 – UART Reset Function Table

REGISTER/SIGNAL	RESET CONTROL	RESET STATE
Interrupt Enable Register	RESET	All bits low
Interrupt Identification Reg.	RESET	Bit 0 is high; Bits 1 - 7 low
FIFO Control	RESET	All bits low
Line Control Reg.	RESET	All bits low
MODEM Control Reg.	RESET	All bits low
Line Status Reg.	RESET	All bits low except 5, 6 high
MODEM Status Reg.	RESET	Bits 0 - 3 low; Bits 4 - 7 input
TXD1, TXD2	RESET	High
INTRPT (RCVR errs)	RESET/Read LSR	Low
INTRPT (RCVR Data Ready)	RESET/Read RBR	Low
INTRPT (THRE)	RESET/ReadIIR/Write THR	Low
OUT2B	RESET	High
RTSB	RESET	High
DTRB	RESET	High
OUT1B	RESET	High
RCVR FIFO	RESET/ FCR1*FCR0/_FCR0	All Bits Low
XMIT FIFO	RESET/ FCR1*FCR0/_FCR0	All Bits Low



Table 8.5 – Register Summary for an Individual UART Channel

REGISTER ADDRESS (Note 8.4)	REGISTER NAME	REGISTER SYMBOL	BIT 0	BIT 1	BIT 2	BIT 3	BIT 4	BIT 5	BIT 6	BIT 7
ADDR = 0 DLAB = 0	Receive Buffer Register (Read Only)	RBR	Data Bit 0 (Note 8.5)	Data Bit 1	Data Bit 2	Data Bit 3	Data Bit 4	Data Bit 5	Data Bit 6	Data Bit 7
ADDR = 0 DLAB = 0	Transmitter Holding Register (Write Only)	THR	Data Bit 0	Data Bit 1	Data Bit 2	Data Bit 3	Data Bit 4	Data Bit 5	Data Bit 6	Data Bit 7
ADDR = 1 DLAB = 0	Interrupt Enable Register	IER	Enable Received Data Available Interrupt (ERDAI)	Enable Transmitter Holding Register Empty Interrupt (ETHREI)	Enable Receiver Line Status Interrupt (ELSI)	Enable MODEM Status Interrupt (EMSI)	0	0	0	0
ADDR = 2	Interrupt Ident. Register (Read Only)	IIR	"0" if Interrupt Pending	Interrupt ID Bit	Interrupt ID Bit	Interrupt ID Bit (Note 8.9)	0	0	FIFOs Enabled (Note 8.9)	FIFOs Enabled (Note 8.9)
ADDR = 2	FIFO Control Register (Write Only)	FCR (Note 8.11)	FIFO Enable	RCVR FIFO Reset	XMIT FIFO Reset	DMA Mode Select (Note 8.10)	Reserved	Reserved	RCVR Trigger LSB	RCVR Trigger MSB
ADDR = 3	Line Control Register	LCR	Word Length Select Bit 0 (WLS0)	Word Length Select Bit 1 (WLS1)	Number of Stop Bits (STB)	Parity Enable (PEN)	Even Parity Select (EPS)	Stick Parity	Set Break	Divisor Latch Access Bit (DLAB)
ADDR = 4	MODEM Control Register	MCR	Data Terminal Ready (DTR)	Request to Send (RTS)	OUT1 (Note 8.7)	OUT2 (Note 8.7)	Loop	0	0	0
ADDR = 5	Line Status Register	LSR	Data Ready (DR)	Overrun Error (OE)	Parity Error (PE)	Framing Error (FE)	Break Interrupt (BI)	Transmitter Holding Register (THRE)	Transmitter Empty (TEMT) (Note 8.6)	Error in RCVR FIFO (Note 8.9)
ADDR = 6	MODEM Status Register	MSR	Delta Clear to Send (DCTS)	Delta Data Set Ready (DDSR)	Trailing Edge Ring Indicator (TERI)	Delta Data Carrier Detect (DDCD)	Clear to Send (CTS)	Data Set Ready (DSR)	Ring Indicator (RI)	Data Carrier Detect (DCD)
ADDR = 7	Scratch Register (Note 5)	SCR	Bit 0	Bit 1	Bit 2	Bit 3	Bit 4	Bit 5	Bit 6	Bit 7
ADDR = 0 DLAB = 1	Divisor Latch (LS)	DDL	Bit 0	Bit 1	Bit 2	Bit 3	Bit 4	Bit 5	Bit 6	Bit 7
ADDR = 1 DLAB = 1	Divisor Latch (MS)	DLM	Bit 8	Bit 9	Bit 10	Bit 11	Bit 12	Bit 13	Bit 14	Bit 15

DATASHEET

- Note 8.4** DLAB is Bit 7 of the Line Control Register (ADDR = 3).
- Note 8.5** Bit 0 is the least significant bit. It is the first bit serially transmitted or received.
- Note 8.6** When operating in the XT mode, this bit will be set any time that the transmitter shift register is empty.
- Note 8.7** This bit no longer has a pin associated with it.
- Note 8.8** When operating in the XT mode, this register is not available.
- Note 8.9** These bits are always zero in the non-FIFO mode.
- Note 8.10** Writing a one to this bit has no effect. DMA modes are not supported in this chip.
- Note 8.11** The UART FCR is shadowed in the UART FIFO Control Shadow Register (CR15).

8.6 Notes On Serial Port Operation

8.6.1 FIFO Mode Operation

GENERAL

The RCVR FIFO will hold up to 16 bytes regardless of which trigger level is selected.

8.6.2 TX AND RX FIFO Operation

The Tx portion of the UART transmits data through TXD as soon as the CPU loads a byte into the Tx FIFO. **The UART will prevent loads to the Tx FIFO if it currently holds 16 characters.** Loading to the Tx FIFO will again be enabled as soon as the next character is transferred to the Tx shift register. These capabilities account for the largely autonomous operation of the Tx.

The UART starts the above operations typically with a Tx interrupt. The chip issues a Tx interrupt whenever the Tx FIFO is empty and the Tx interrupt is enabled, except in the following instance. Assume that the Tx FIFO is empty and the CPU starts to load it. When the first byte enters the FIFO the Tx FIFO empty interrupt will transition from active to inactive. Depending on the execution speed of the service routine software, the UART may be able to transfer this byte from the FIFO to the shift register before the CPU loads another byte. If this happens, the Tx FIFO will be empty again and typically the UART's interrupt line would transition to the active state. This could cause a system with an interrupt control unit to record a Tx FIFO empty condition, even though the CPU is currently servicing that interrupt. **Therefore, after the first byte has been loaded into the FIFO the UART will wait one serial character transmission time before issuing a new Tx FIFO empty interrupt. This one character Tx interrupt delay will remain active until at least two bytes have the Tx FIFO empties after this condition, the Tx been loaded into the FIFO, concurrently. When interrupt will be activated without a one character delay.**

Rx support functions and operation are quite different from those described for the transmitter. The Rx FIFO receives data until the number of bytes in the FIFO equals the selected interrupt trigger level. At that time if Rx interrupts are enabled, the UART will issue an interrupt to the CPU. The Rx FIFO will continue to store bytes until it holds 16 of them. It will not accept any more data when it is full. Any more data entering the Rx shift register will set the Overrun Error flag. Normally, the FIFO depth and the programmable trigger levels will give the CPU ample time to empty the Rx FIFO before an overrun occurs.



One side-effect of having a Rx FIFO is that the selected interrupt trigger level may be above the data level in the FIFO. This could occur when data at the end of the block contains fewer bytes than the trigger level. No interrupt would be issued to the CPU and the data would remain in the UART. **To prevent the software from having to check for this situation the chip incorporates a timeout interrupt.**

The timeout interrupt is activated when there is a least one byte in the Rx FIFO, and neither the CPU nor the Rx shift register has accessed the Rx FIFO within 4 character times of the last byte. The timeout interrupt is cleared or reset when the CPU reads the Rx FIFO or another character enters it.

These FIFO related features allow optimization of CPU/UART transactions and are especially useful given the higher baud rate capability (256 kbaud).

Chapter 9 Parallel Port

The LPC47N237 incorporates an IBM XT/AT compatible parallel port. This supports the optional PS/2 type bi-directional parallel port (SPP), the Enhanced Parallel Port (EPP) and the Extended Capabilities Port (ECP) parallel port modes. Refer to the Configuration Registers for information on disabling, power down, changing the base address of the parallel port, and selecting the mode of operation.

The parallel port also incorporates SMSC's ChiProtect circuitry, which prevents possible damage to the parallel port due to printer power-up.

The functionality of the Parallel Port is achieved through the use of eight addressable ports, with their associated registers and control gating. The control and data port are read/write by the CPU, the status port is read/write in the EPP mode. The address map of the Parallel Port is shown below.

DATA PORT	BASE ADDRESS + 00H
STATUS PORT	BASE ADDRESS + 01H
CONTROL PORT	BASE ADDRESS + 02H
EPP ADDR PORT	BASE ADDRESS + 03H
EPP DATA PORT 0	BASE ADDRESS + 04H
EPP DATA PORT 1	BASE ADDRESS + 05H
EPP DATA PORT 2	BASE ADDRESS + 06H
EPP DATA PORT 3	BASE ADDRESS + 07H

The bit map of these registers is:

	D0	D1	D2	D3	D4	D5	D6	D7	NOTE
DATA PORT	PD0	PD1	PD2	PD3	PD4	PD5	PD6	PD7	(Note 9.1)
STATUS PORT	TMOUT	0	0	nERR	SLCT	PE	nACK	nBUSY	(Note 9.1)
CONTROL PORT	STROBE	AUTOFD	nINIT	SLC	IRQE	PCD	0	0	(Note 9.1)
EPP ADDR PORT	PD0	PD1	PD2	PD3	PD4	PD5	PD6	PD7	(Note 9.2)
EPP DATA PORT 0	PD0	PD1	PD2	PD3	PD4	PD5	PD6	PD7	(Note 9.2)
EPP DATA PORT 1	PD0	PD1	PD2	PD3	PD4	PD5	PD6	PD7	(Note 9.2)
EPP DATA PORT 2	PD0	PD1	PD2	PD3	PD4	PD5	PD6	PD7	(Note 9.2)
EPP DATA PORT 3	PD0	PD1	PD2	PD3	PD4	PD5	PD6	PD7	(Note 9.2)

Note 9.1 These registers are available in all modes.

Note 9.2 These registers are only available in EPP mode.

Table 9.1 - Parallel Port Connector

HOST CONNECTOR	SMSC PIN NUMBER	STANDARD	EPP	ECP
1	83	nSTROBE	nWrite	nStrobe
2-9	68-75	PD<0:7>	PData<0:7>	PData<0:7>
10	80	nACK	Intr	nAck
11	79	BUSY	nWait	Busy, PeriphAck(3)
12	78	PE	(User Defined)	PError, nAckReverse(3)
13	77	SLCT	(User Defined)	Select
14	82	nALF	nDatastb	nAutoFd, HostAck(3)
15	81	nERROR	(User Defined)	nFault(1) nPeriphRequest(3)
16	66	nINIT	nRESET	nInit(1) nReverseRqst(3)
17	67	nSLCTIN	nAddrstrb	nSelectIn(1,3)

(1) = Compatible Mode

(3) = High Speed Mode

Note: For the cable interconnection required for ECP support and the Slave Connector pin numbers, refer to the IEEE 1284 Extended Capabilities Port Protocol and ISA Standard, Rev. 1.14, July 14, 1993. This document is available from Microsoft.

9.1 IBM XT/AT Compatible, Bi-Directional And EPP Modes

9.1.1 Data Port

ADDRESS OFFSET = 00H

The Data Port is located at an offset of '00H' from the base address. The data register is cleared at initialization by RESET. During a WRITE operation, the Data Register latches the contents of the internal data bus. The contents of this register are buffered (non inverting) and output onto the PD0 - PD7 ports. During a READ operation in SPP mode, PD0 - PD7 ports are buffered (not latched) and output to the host CPU.

9.1.2 Status Port

ADDRESS OFFSET = 01H

The Status Port is located at an offset of '01H' from the base address. The contents of this register are latched for the duration of a read cycle. The bits of the Status Port are defined as follows:

BIT 0 TMOUT - TIME OUT

This bit is valid in EPP mode only and indicates that a 10 usec time out has occurred on the EPP bus. A logic zero means that no time out error has occurred; a logic 1 means that a time out error has been detected.

The means of clearing the TIMEOUT bit is controlled by the TIMEOUT_SELECT bit as follows. The TIMEOUT_SELECT bit is located at bit 2 of CR21.

- If the TIMEOUT_SELECT bit is cleared ('0'), the TIMEOUT bit is cleared on the trailing edge of the read of the EPP Status Register (default)
- If the TIMEOUT_SELECT bit is set ('1'), the TIMEOUT bit is cleared on a write of '1' to the TIMEOUT bit.

The TIMEOUT bit is cleared on PCI_RESET regardless of the state of the TIMEOUT_SELECT bit.

BITS 1, 2 - are not implemented as register bits, during a read of the Printer Status Register these bits are a low level.

BIT 3 nERR - nERROR

The level on the nERROR input is read by the CPU as bit 3 of the Printer Status Register. A logic 0 means an error has been detected; a logic 1 means no error has been detected.

BIT 4 SLCT - PRINTER SELECTED STATUS

The level on the SLCT input is read by the CPU as bit 4 of the Printer Status Register. A logic 1 means the printer is on line; a logic 0 means it is not selected.

BIT 5 PE - PAPER END

The level on the PE input is read by the CPU as bit 5 of the Printer Status Register. A logic 1 indicates a paper end; a logic 0 indicates the presence of paper.

BIT 6 nACK - nACKNOWLEDGE

The level on the nACK input is read by the CPU as bit 6 of the Printer Status Register. A logic 0 means that the printer has received a character and can now accept another. A logic 1 means that it is still processing the last character or has not received the data.

BIT 7 nBUSY - nBUSY

The complement of the level on the BUSY input is read by the CPU as bit 7 of the Printer Status Register. A logic 0 in this bit means that the printer is busy and cannot accept a new character. A logic 1 means that it is ready to accept the next character.

9.1.3 Control Port

ADDRESS OFFSET = 02H

The Control Port is located at an offset of '02H' from the base address. The Control Register is initialized by the RESET input, bits 0 to 5 only being affected; bits 6 and 7 are hard wired low.

BIT 0 STROBE - STROBE

This bit is inverted and output onto the nSTROBE output.

BIT 1 AUTOFD - AUTOFEED

This bit is inverted and output onto the nAUTOFD output. A logic 1 causes the printer to generate a line feed after each line is printed. A logic 0 means no autofeed.

BIT 2 nINIT - nINITIATE OUTPUT

This bit is output onto the nINIT output without inversion.

BIT 3 SLCTIN - PRINTER SELECT INPUT

This bit is inverted and output onto the nSLCTIN output. A logic 1 on this bit selects the printer; a logic 0 means the printer is not selected.

BIT 4 IRQE - INTERRUPT REQUEST ENABLE

The interrupt request enable bit when set to a high level may be used to enable interrupt requests from the Parallel Port to the CPU. An interrupt request is generated on the IRQ port by a positive going nACK input. When the IRQE bit is programmed low the IRQ is disabled.

BIT 5 PCD - PARALLEL CONTROL DIRECTION

Parallel Control Direction is not valid in printer mode. In printer mode, the direction is always out regardless of the state of this bit. In bi-directional, EPP or ECP mode, a logic 0 means that the printer port is in output mode (write); a logic 1 means that the printer port is in input mode (read).

Bits 6 and 7 during a read are a low level, and cannot be written.

9.1.4 EPP Address Port

ADDRESS OFFSET = 03H

The EPP Address Port is located at an offset of '03H' from the base address. The address register is cleared at initialization by RESET. During a WRITE operation, the contents of the internal data bus DB0-DB7 are buffered (non inverting) and output onto the PD0 - PD7 ports. An LPC I/O write cycle causes an EPP ADDRESS WRITE cycle to be performed, during which the data is latched for the duration of the EPP write cycle. During a READ operation, PD0 - PD7 ports are read. An LPC I/O read cycle causes an EPP ADDRESS READ cycle to be performed and the data output to the host CPU, the deassertion of ADDRSTB latches the PData for the duration of the read cycle. This register is only available in EPP mode.

9.1.5 EPP Data Port 0

ADDRESS OFFSET = 04H

The EPP Data Port 0 is located at an offset of '04H' from the base address. The data register is cleared at initialization by RESET. During a WRITE operation, the contents of the internal data bus DB0-DB7 are buffered (non inverting) and output onto the PD0 - PD7 ports. An LPC I/O write cycle causes an EPP DATA WRITE cycle to be performed, during which the data is latched for the duration of the EPP write cycle. During a READ operation, PD0 - PD7 ports are read. An LPC I/O read cycle causes an EPP READ cycle to be performed and the data output to the host CPU, the deassertion of DATASTB latches the PData for the duration of the read cycle. This register is only available in EPP mode.

9.1.6 EPP Data Port 1

ADDRESS OFFSET = 05H

The EPP Data Port 1 is located at an offset of '05H' from the base address. Refer to EPP DATA PORT 0 for a description of operation. This register is only available in EPP mode.

9.1.7 EPP Data Port 2

ADDRESS OFFSET = 06H

The EPP Data Port 2 is located at an offset of '06H' from the base address. Refer to EPP DATA PORT 0 for a description of operation. This register is only available in EPP mode.

9.1.8 EPP Data Port 3

ADDRESS OFFSET = 07H

The EPP Data Port 3 is located at an offset of '07H' from the base address. Refer to EPP DATA PORT 0 for a description of operation. This register is only available in EPP mode.

9.2 EPP 1.9 Operation

When the EPP mode is selected in the configuration register, the standard and bi-directional modes are also available. If no EPP Read, Write or Address cycle is currently executing, then the PDx bus is in the standard or bi-directional mode, and all output signals (STROBE, AUTOFD, INIT) are as set by the SPP Control Port and direction is controlled by PCD of the Control port.

In EPP mode, the system timing is closely coupled to the EPP timing. For this reason, a watchdog timer is required to prevent system lockup. The timer indicates if more than 10usec have elapsed from the start of the EPP cycle to nWAIT being deasserted (after command). If a time-out occurs, the current EPP cycle is aborted and the time-out condition is indicated in Status bit 0.

During an EPP cycle, if STROBE is active, it overrides the EPP write signal forcing the PDx bus to always be in a write mode and the nWRITE signal to always be asserted.

9.2.1 Software Constraints

Before an EPP cycle is executed, the software must ensure that the control register bit PCD is a logic "0" (i.e., a 04H or 05H should be written to the Control port). If the user leaves PCD as a logic "1", and attempts to perform an EPP write, the chip is unable to perform the write (because PCD is a logic "1") and will appear to perform an EPP read on the parallel bus, no error is indicated.

9.2.2 EPP 1.9 Write

The timing for a write operation (address or data) is shown in timing diagram EPP Write Data or Address cycle. The chip inserts wait states into the LPC I/O write cycle until it has been determined that the write cycle can complete. The write cycle can complete under the following circumstances:

1. If the EPP bus is not ready (nWAIT is active low) when nDATASTB or nADDRSTB goes active then the write can complete when nWAIT goes inactive high.
2. If the EPP bus is ready (nWAIT is inactive high) then the chip must wait for it to go active low before changing the state of nDATASTB, nWRITE or nADDRSTB. The write can complete once nWAIT is determined inactive.

Write Sequence of operation

1. The host initiates an I/O write cycle to the selected EPP register.
2. If WAIT is not asserted, the chip must wait until WAIT is asserted.
3. The chip places address or data on PData bus, clears PDIR, and asserts nWRITE.
4. Chip asserts nDATASTB or nADDRSTRB indicating that PData bus contains valid information, and the WRITE signal is valid.
5. Peripheral deasserts nWAIT, indicating that any setup requirements have been satisfied and the chip may begin the termination phase of the cycle.
6. a.) The chip deasserts nDATASTB or nADDRSTRB, this marks the beginning of the termination phase. If it has not already done so, the peripheral should latch the information byte now.
b.) The chip latches the data from the internal data bus for the PData bus and drives the sync that indicates that no more wait states are required followed by the TAR to complete the write cycle.
7. Peripheral asserts nWAIT, indicating to the host that any hold time requirements have been satisfied and acknowledging the termination of the cycle.
8. Chip may modify nWRITE and nPDATA in preparation for the next cycle.

9.2.3 EPP 1.9 Read

The timing for a read operation (data) is shown in timing diagram EPP Read Data cycle. The chip inserts wait states into the LPC I/O read cycle until it has been determined that the read cycle can complete. The read cycle can complete under the following circumstances:

1. If the EPP bus is not ready (nWAIT is active low) when nDATASTB goes active then the read can complete when nWAIT goes inactive high.
2. If the EPP bus is ready (nWAIT is inactive high) then the chip must wait for it to go active low before changing the state of WRITE or before nDATASTB goes active. The read can complete once nWAIT is determined inactive.

Read Sequence of Operation

1. The host initiates an I/O read cycle to the selected EPP register.
2. If WAIT is not asserted, the chip must wait until WAIT is asserted.
3. The chip tri-states the PData bus and deasserts nWRITE.
4. Chip asserts nDATASTB or nADDRSTRB indicating that PData bus is tri-stated, PDIR is set and the nWRITE signal is valid.
5. Peripheral drives PData bus valid.
6. Peripheral deasserts nWAIT, indicating that PData is valid and the chip may begin the termination phase of the cycle.
7. a.) The chip latches the data from the PData bus for the internal data bus and deasserts nDATASTB or nADDRSTRB. This marks the beginning of the termination phase.
b.) The chip drives the sync that indicates that no more wait states are required and drives valid data onto the LAD[3:0] signals, followed by the TAR to complete the read cycle.
8. Peripheral tri-states the PData bus and asserts nWAIT, indicating to the host that the PData bus is tri-stated.
9. Chip may modify nWRITE, PDIR and nPDATA in preparation for the next cycle.

9.3 EPP 1.7 Operation

When the EPP 1.7 mode is selected in the configuration register, the standard and bi-directional modes are also available. If no EPP Read, Write or Address cycle is currently executing, then the PDx bus is in the standard or bi-directional mode, and all output signals (STROBE, AUTOFD, INIT) are as set by the SPP Control Port and direction is controlled by PCD of the Control port.

In EPP mode, the system timing is closely coupled to the EPP timing. For this reason, a watchdog timer is required to prevent system lockup. The timer indicates if more than 10usec have elapsed from the start of the EPP cycle to the end of the cycle. If a time-out occurs, the current EPP cycle is aborted and the time-out condition is indicated in Status bit 0.

9.3.1 Software Constraints

Before an EPP cycle is executed, the software must ensure that the control register bits D0, D1 and D3 are set to zero. Also, bit D5 (PCD) is a logic "0" for an EPP write or a logic "1" for an EPP read.

9.3.2 EPP 1.7 Write

The timing for a write operation (address or data) is shown in timing diagram EPP 1.7 Write Data or Address cycle. The chip inserts wait states into the I/O write cycle when nWAIT is active low during the EPP cycle. This can be used to extend the cycle time. The write cycle can complete when nWAIT is inactive high.

Write Sequence of Operation

1. The host sets PDIR bit in the control register to a logic "0". This asserts nWRITE.
2. The host initiates an I/O write cycle to the selected EPP register.
3. The chip places address or data on PData bus.
4. Chip asserts nDATASTB or nADDRSTRB indicating that PData bus contains valid information, and the WRITE signal is valid.
5. If nWAIT is asserted, the chip inserts wait states into I/O write cycle until the peripheral deasserts nWAIT or a time-out occurs.
6. The chip drives the final sync, deasserts nDATASTB or nADDRSTRB and latches the data from the internal data bus for the PData bus.
7. Chip may modify nWRITE, PDIR and nPDATA in preparation of the next cycle.

9.3.3 EPP 1.7 Read

The timing for a read operation (data) is shown in timing diagram EPP 1.7 Read Data cycle. The chip inserts wait states into the I/O read cycle when nWAIT is active low during the EPP cycle. This can be used to extend the cycle time. The read cycle can complete when nWAIT is inactive high.

Read Sequence of Operation

1. The host sets PDIR bit in the control register to a logic "1". This deasserts nWRITE and tri-states the PData bus.
2. The host initiates an I/O read cycle to the selected EPP register.
3. Chip asserts nDATASTB or nADDRSTRB indicating that PData bus is tri-stated, PDIR is set and the nWRITE signal is valid.

4. If nWAIT is asserted, the chip inserts wait states into the I/O read cycle until the peripheral deasserts nWAIT or a time-out occurs.
5. The Peripheral drives PData bus valid.
6. The Peripheral deasserts nWAIT, indicating that PData is valid and the chip may begin the termination phase of the cycle.
7. The chip drives the final sync and deasserts nDATASTB or nADDRSTRB.
8. Peripheral tri-states the PData bus.
9. Chip may modify nWRITE, PDIR and nPDATA in preparation of the next cycle.

Table 9.2 - EPP Pin Descriptions

EPP SIGNAL	EPP NAME	TYPE	EPP DESCRIPTION
nWRITE	nWrite	O	This signal is active low. It denotes a write operation.
PD<0:7>	Address/Data	I/O	Bi-directional EPP byte wide address and data bus.
INTR	Interrupt	I	This signal is active high and positive edge triggered. (Pass through with no inversion, Same as SPP).
WAIT	nWait	I	This signal is active low. It is driven inactive as a positive acknowledgement from the device that the transfer of data is completed. It is driven active as an indication that the device is ready for the next transfer.
DATASTB	nData Strobe	O	This signal is active low. It is used to denote data read or write operation.
RESET	nReset	O	This signal is active low. When driven active, the EPP device is reset to its initial operational mode.
ADDRSTB	nAddress Strobe	O	This signal is active low. It is used to denote address read or write operation.
PE	Paper End	I	Same as SPP mode.
SLCT	Printer Selected Status	I	Same as SPP mode.
nERR	Error	I	Same as SPP mode.

Notes:

- SPP and EPP can use 1 common register.
- nWrite is the only EPP output that can be over-riden by SPP control port during an EPP cycle. For correct EPP read cycles, PCD is required to be a low.

9.4 Extended Capabilities Parallel Port

ECP provides a number of advantages, some of which are listed below. The individual features are explained in greater detail in the remainder of this section.

High performance half-duplex forward and reverse channel Interlocked handshake, for fast reliable transfer
 Optional single byte RLE compression for improved throughput (64:1)
 Channel addressing for low-cost peripherals
 Maintains link and data layer separation
 Permits the use of active output drivers
 permits the use of adaptive signal timing
 Peer-to-peer capability.

9.5 Vocabulary

The following terms are used in this document:

Assert: When a signal asserts it transitions to a "true" state, when a signal deasserts it transitions to a "false" state.

- forward: Host to Peripheral communication.
 reverse: Peripheral to Host communication
 Pword: A port word; equal in size to the width of the LPC interface. For this implementation, PWord is always 8 bits.
 1 A high level.
 0 A low level.

These terms may be considered synonymous:

PeriphClk, nAck
 HostAck, nAutoFd
 PeriphAck, Busy
 nPeriphRequest, nFault
 nReverseRequest, nInIt
 nAckReverse, PError
 Xflag, Select
 ECPMode, nSelectIn
 HostClk, nStrobe

Reference Document: IEEE 1284 Extended Capabilities Port Protocol and ISA Interface Standard, Rev 1.14, July 14, 1993. This document is available from Microsoft.

The bit map of the Extended Parallel Port registers is:

	D7	D6	D5	D4	D3	D2	D1	D0	NOTE	
data	PD7	PD6	PD5	PD4	PD3	PD2	PD1	PD0		
ecpAFifo	Addr/RLE	Address or RLE field							(Note 9.4)	
dsr	nBusy	nAck	PError	Select	nFault	0	0	0	(Note 9.3)	
dcr	0	0	Direction	ackIntEn	SelectIn	nInIt	autof d	strobe	(Note 9.3)	
cFifo	Parallel Port Data FIFO								(Note 9.4)	
ecpDFifo	ECP Data FIFO								(Note 9.4)	
tFifo	Test FIFO								(Note 9.4)	
cnfgA	0	0	0	1	0	0	0	0		
cnfgB	compress	intrValue	Parallel Port IRQ			Parallel Port DMA				
ecr	MODE			nErrIntrEn	dmaEn	servicIn tr	full	empty		

Note 9.3 These registers are available in all modes.

Note 9.4 All FIFOs use one common 16 byte FIFO.

Note 9.5 The ECP Parallel Port Config Reg B reflects the IRQ and DMA channel selected by the Configuration Registers.

9.6 ECP Implementation Standard

This specification describes the standard interface to the Extended Capabilities Port (ECP). All LPC devices supporting ECP must meet the requirements contained in this section or the port will not be supported by Microsoft. For a description of the ECP Protocol, please refer to the IEEE 1284 Extended Capabilities Port Protocol and ISA Interface Standard, Rev. 1.14, July 14, 1993. This document is available from Microsoft.

9.6.1 Description

The port is software and hardware compatible with existing parallel ports so that it may be used as a standard LPT port if ECP is not required. The port is designed to be simple and requires a small number of gates to implement. It does not do any "protocol" negotiation, rather it provides an automatic high burst-bandwidth channel that supports DMA for ECP in both the forward and reverse directions.

Small FIFOs are employed in both forward and reverse directions to smooth data flow and improve the maximum bandwidth requirement. The size of the FIFO is 16 bytes deep. The port supports an automatic handshake for the standard parallel port to improve compatibility mode transfer speed.

The port also supports run length encoded (RLE) decompression (required) in hardware. Compression is accomplished by counting identical bytes and transmitting an RLE byte that indicates how many times the next byte is to be repeated. Decompression simply intercepts the RLE byte and repeats the following byte the specified number of times. Hardware support for compression is optional.

Table 9.3 - ECP Pin Descriptions

NAME	TYPE	DESCRIPTION
nStrobe	O	During write operations nStrobe registers data or address into the slave on the asserting edge (handshakes with Busy).
PData 7:0	I/O	Contains address or data or RLE data.
nAck	I	Indicates valid data driven by the peripheral when asserted. This signal handshakes with nAutoFd in reverse.
PeriphAck (Busy)	I	This signal deasserts to indicate that the peripheral can accept data. This signal handshakes with nStrobe in the forward direction. In the reverse direction this signal indicates whether the data lines contain ECP command information or data. The peripheral uses this signal to flow control in the forward direction. It is an "interlocked" handshake with nStrobe. PeriphAck also provides command information in the reverse direction.
PError (nAckReverse)	I	Used to acknowledge a change in the direction the transfer (asserted = forward). The peripheral drives this signal low to acknowledge nReverseRequest. It is an "interlocked" handshake with nReverseRequest. The host relies upon nAckReverse to determine when it is permitted to drive the data bus.
Select	I	Indicates printer on line.

NAME	TYPE	DESCRIPTION
nAutoFd (HostAck)	O	Requests a byte of data from the peripheral when asserted, handshaking with nAck in the reverse direction. In the forward direction this signal indicates whether the data lines contain ECP address or data. The host drives this signal to flow control in the reverse direction. It is an "interlocked" handshake with nAck. HostAck also provides command information in the forward phase.
nFault (nPeriphRequest)	I	Generates an error interrupt when asserted. This signal provides a mechanism for peer-to-peer communication. This signal is valid only in the forward direction. During ECP Mode the peripheral is permitted (but not required) to drive this pin low to request a reverse transfer. The request is merely a "hint" to the host; the host has ultimate control over the transfer direction. This signal would be typically used to generate an interrupt to the host CPU.
nInit	O	Sets the transfer direction (asserted = reverse, deasserted = forward). This pin is driven low to place the channel in the reverse direction. The peripheral is only allowed to drive the bi-directional data bus while in ECP Mode and HostAck is low and nSelectIn is high.
nSelectIn	O	Always deasserted in ECP mode.

9.6.2 Register Definitions

The register definitions are based on the standard IBM addresses for LPT. All of the standard printer ports are supported. The additional registers attach to an upper bit decode of the standard LPT port definition to avoid conflict with standard ISA devices. The port is equivalent to a generic parallel port interface and may be operated in that mode. The port registers vary depending on the mode field in the ecr. The table below lists these dependencies. Operation of the devices in modes other than those specified is undefined.

Table 9.4 - ECP Register Definitions

NAME	ADDRESS (NOTE 9.6)	ECP MODES	FUNCTION
data	+000h R/W	000-001	Data Register
ecpAFifo	+000h R/W	011	ECP FIFO (Address)
dsr	+001h R/W	All	Status Register
dcr	+002h R/W	All	Control Register
cFifo	+400h R/W	010	Parallel Port Data FIFO
ecpDFifo	+400h R/W	011	ECP FIFO (DATA)
tFifo	+400h R/W	110	Test FIFO
cnfgA	+400h R	111	Configuration Register A
cnfgB	+401h R/W	111	Configuration Register B
ecr	+402h R/W	All	Extended Control Register

Note 9.6 These addresses are added to the parallel port base address as selected by configuration register or jumpers.

Note 9.7 All addresses are qualified with AEN. Refer to the AEN pin definition.

Table 9.5 – Parallel Port Mode Description

MODE	DESCRIPTION (NOTE 9.8)
000	SPP mode
001	PS/2 Parallel Port mode
010	Parallel Port Data FIFO mode
011	ECP Parallel Port mode
100	EPP mode (If this option is enabled in the configuration registers)
101	Reserved
110	Test mode
111	Configuration mode

Note 9.8 Refer to ECR Register Description

Data And ecpAFifo Port

ADDRESS OFFSET = 00H

Modes 000 and 001 (Data Port)

The Data Port is located at an offset of '00H' from the base address. The data register is cleared at initialization by RESET. During a WRITE operation, the Data Register latches the contents of the data bus. The contents of this register are buffered (non inverting) and output onto the PD0 - PD7 ports. During a READ operation, PD0 - PD7 ports are read and output to the host CPU.

Mode 011 (ECP FIFO - Address/RLE)

A data byte written to this address is placed in the FIFO and tagged as an ECP Address/RLE. The hardware at the ECP port transmits this byte to the peripheral automatically. The operation of this register is only defined for the forward direction (direction is 0). Refer to the ECP Parallel Port Forward Timing Diagram, located in the Timing Diagrams section of this data sheet .

Device Status Register (DSR)

ADDRESS OFFSET = 01H

The Status Port is located at an offset of '01H' from the base address. Bits 0 - 2 are not implemented as register bits, during a read of the Printer Status Register these bits are a low level. The bits of the Status Port are defined as follows:

BIT 3 nFault

The level on the nFault input is read by the CPU as bit 3 of the Device Status Register.

BIT 4 Select

The level on the Select input is read by the CPU as bit 4 of the Device Status Register.

BIT 5 PError

The level on the PError input is read by the CPU as bit 5 of the Device Status Register. Printer Status Register.

BIT 6 nAck

The level on the nAck input is read by the CPU as bit 6 of the Device Status Register.

BIT 7 nBusy

The complement of the level on the BUSY input is read by the CPU as bit 7 of the Device Status Register.

Device Control Register (DCR)**ADDRESS OFFSET = 02H**

The Control Register is located at an offset of '02H' from the base address. The Control Register is initialized to zero by the RESET input, bits 0 to 5 only being affected; bits 6 and 7 are hard wired low.

BIT 0 STROBE - STROBE

This bit is inverted and output onto the nSTROBE output.

BIT 1 AUTOFD - AUTOFEED

This bit is inverted and output onto the nAUTOFD output. A logic 1 causes the printer to generate a line feed after each line is printed. A logic 0 means no autofeed.

BIT 2 nINIT - nINITIATE OUTPUT

This bit is output onto the nINIT output without inversion.

BIT 3 SELECTIN

This bit is inverted and output onto the nSLCTIN output. A logic 1 on this bit selects the printer; a logic 0 means the printer is not selected.

BIT 4 ackIntEn - INTERRUPT REQUEST ENABLE

The interrupt request enable bit when set to a high level may be used to enable interrupt requests from the Parallel Port to the CPU due to a low to high transition on the nACK input. Refer to the description of the interrupt under Operation, Interrupts.

BIT 5 DIRECTION

If mode=000 or mode=010, this bit has no effect and the direction is always out regardless of the state of this bit. In all other modes, Direction is valid and a logic 0 means that the printer port is in output mode (write); a logic 1 means that the printer port is in input mode (read).

BITS 6 and 7 during a read are a low level, and cannot be written.

cFifo (Parallel Port Data FIFO)

ADDRESS OFFSET = 400h

Mode = 010

Bytes written or DMAed from the system to this FIFO are transmitted by a hardware handshake to the peripheral using the standard parallel port protocol. Transfers to the FIFO are byte aligned. This mode is only defined for the forward direction.

ecpDFifo (ECP Data FIFO)

ADDRESS OFFSET = 400H

Mode = 011

Bytes written or DMAed from the system to this FIFO, when the direction bit is 0, are transmitted by a hardware handshake to the peripheral using the ECP parallel port protocol. Transfers to the FIFO are byte aligned.

Data bytes from the peripheral are read under automatic hardware handshake from ECP into this FIFO when the direction bit is 1. Reads or DMAs from the FIFO will return bytes of ECP data to the system.

tFifo (Test FIFO Mode)

ADDRESS OFFSET = 400H

Mode = 110

Data bytes may be read, written or DMAed to or from the system to this FIFO in any direction. Data in the tFIFO will not be transmitted to the parallel port lines using a hardware protocol handshake. However, data in the tFIFO may be displayed on the parallel port data lines.

The tFIFO will not stall when overwritten or underrun. If an attempt is made to write data to a full tFIFO, the new data is not accepted into the tFIFO. If an attempt is made to read data from an empty tFIFO, the last data byte is re-read again. The full and empty bits must always keep track of the correct FIFO state. The tFIFO will transfer data at the maximum ISA rate so that software may generate performance metrics.

The FIFO size and interrupt threshold can be determined by writing bytes to the FIFO and checking the full and serviceIntr bits.

The writeIntrThreshold can be determined by starting with a full tFIFO, setting the direction bit to 0 and emptying it a byte at a time until serviceIntr is set. This may generate a spurious interrupt, but will indicate that the threshold has been reached.

The readIntrThreshold can be determined by setting the direction bit to 1 and filling the empty tFIFO a byte at a time until serviceIntr is set. This may generate a spurious interrupt, but will indicate that the threshold has been reached.

Data bytes are always read from the head of tFIFO regardless of the value of the direction bit. For example if 44h, 33h, 22h is written to the FIFO, then reading the tFIFO will return 44h, 33h, 22h in the same order as was written.

cnfgA (Configuration Register A)

ADDRESS OFFSET = 400H

Mode = 111

This register is a read only register. When read, 10H is returned. This indicates to the system that this is an 8-bit implementation. (PWord = 1 byte)

cnfgB (Configuration Register B)

ADDRESS OFFSET = 401H

Mode = 111

BIT 7 compress

This bit is read only. During a read it is a low level. This means that this chip does not support hardware RLE compression. It does support hardware de-compression!

BIT 6 intrValue

Returns the value of the interrupt to determine possible conflicts.

BITS [5:3] Parallel Port IRQ (read-only)

Refer to Table 9.7.

BITS [2:0] Parallel Port DMA (read-only)

Refer to Table 9.8.

ecr (Extended Control Register)

ADDRESS OFFSET = 402H

Mode = all

This register controls the extended ECP parallel port functions.

BITS 7,6,5

These bits are Read/Write and select the Mode.

BIT 4 nErrIntrEn

Read/Write (Valid only in ECP Mode)

- 1: Disables the interrupt generated on the asserting edge of nFault.
- 0: Enables an interrupt pulse on the high to low edge of nFault. Note that an interrupt will be generated if nFault is asserted (interrupting) and this bit is written from a 1 to a 0. This prevents interrupts from being lost in the time between the read of the ecr and the write of the ecr.

BIT 3 dmaEn

Read/Write

- 1: Enables DMA (DMA starts when serviceIntr is 0).
- 0: Disables DMA unconditionally.

BIT 2 serviceIntr

Read/Write

- 1: Disables DMA and all of the service interrupts.
- 0: Enables one of the following 3 cases of interrupts. Once one of the 3 service interrupts has occurred serviceIntr bit shall be set to a 1 by hardware. It must be reset to 0 to re-enable the interrupts. Writing this bit to a 1 will not cause an interrupt.

case dmaEn=1:

During DMA (this bit is set to a 1 when terminal count is reached).

case dmaEn=0 direction=0:

This bit shall be set to 1 whenever there are writeIntrThreshold or more bytes free in the FIFO.

case dmaEn=0 direction=1:

This bit shall be set to 1 whenever there are readIntrThreshold or more valid bytes to be read from the FIFO.

BIT 1 full

Read only

- 1: The FIFO cannot accept another byte or the FIFO is completely full.
- 0: The FIFO has at least 1 free byte.

BIT 0 empty

Read only

- 1: The FIFO is completely empty.
- 0: The FIFO contains at least 1 byte of data.

Table 9.6 - Extended Control Register

R/W	MODE
000:	Standard Parallel Port Mode . In this mode the FIFO is reset and common drain drivers are used on the control lines (nStrobe, nAutoFd, nInIt and nSelectIn). Setting the direction bit will not tri-state the output drivers in this mode.
001:	PS/2 Parallel Port Mode. Same as above except that direction may be used to tri-state the data lines and reading the data register returns the value on the data lines and not the value in the data register. All drivers have active pull-ups (push-pull).
010:	Parallel Port FIFO Mode. This is the same as 000 except that bytes are written or DMAed to the FIFO. FIFO data is automatically transmitted using the standard parallel port protocol. Note that this mode is only useful when direction is 0. All drivers have active pull-ups (push-pull).
011:	ECP Parallel Port Mode. In the forward direction (direction is 0) bytes placed into the ecpDFifo and bytes written to the ecpAFifo are placed in a single FIFO and transmitted automatically to the peripheral using ECP Protocol. In the reverse direction (direction is 1) bytes are moved from the ECP parallel port and packed into bytes in the ecpDFifo. All drivers have active pull-ups (push-pull).
100:	Selects EPP Mode: In this mode, EPP is selected if the EPP supported option is selected in configuration register CR04 (Bits[1,0] and Bit[6]). All drivers have active pull-ups (push-pull).
101:	Reserved
110:	Test Mode. In this mode the FIFO may be written and read, but the data will not be transmitted on the parallel port. All drivers have active pull-ups (push-pull).
111:	Configuration Mode. In this mode the configA, configB registers are accessible at 0x400 and 0x401. All drivers have active pull-ups (push-pull).

Table 9.7 - Parallel Port IRQ Selection

IRQ SELECTED	CNFGB BITS [5:3]
15	110
14	101
11	100
10	011
9	010
7	001
5	111
All Others	000

Table 9.8 - Parallel Port DMA Selection

DMA SELECTED	CNFGB BITS [2:0]
3	011
2	010
1	001
All Others	000

9.6.3 Operation

Mode Switching/Software Control

Software will execute P1284 negotiation and all operation prior to a data transfer phase under programmed I/O control (mode 000 or 001). Hardware provides an automatic control line handshake, moving data between the FIFO and the ECP port only in the data transfer phase (modes 011 or 010).

Setting the mode to 011 or 010 will cause the hardware to initiate data transfer.

If the port is in mode 000 or 001 it may switch to any other mode. If the port is not in mode 000 or 001 it can only be switched into mode 000 or 001. The direction can only be changed in mode 001.

ECP Operation

Prior to ECP operation the Host must negotiate on the parallel port to determine if the peripheral supports the ECP protocol. This is a somewhat complex negotiation carried out under program control in mode 000.

After negotiation, it is necessary to initialize some of the port bits. The following are required:

Set `Direction = 0`, enabling the drivers.

Set `strobe = 0`, causing the `nStrobe` signal to default to the deasserted state.

Set `autoFd = 0`, causing the `nAutoFd` signal to default to the deasserted state.

Set `mode = 011` (ECP Mode)

ECP address/RLE bytes or data bytes may be sent automatically by writing the `ecpAFifo` or `ecpDFifo` respectively.

Note that all FIFO data transfers are byte wide and byte aligned. Address/RLE transfers are byte-wide and only allowed in the forward direction.

The host may switch directions by first switching to mode = 001, negotiating for the forward or reverse channel, setting direction to 1 or 0, then setting mode = 011. When direction is 1 the hardware shall handshake for each ECP read data byte and attempt to fill the FIFO. Bytes may then be read from the `ecpDFifo` as long as it is not empty.

ECP transfers may also be accomplished (albeit slowly) by handshaking individual bytes under program control in mode = 001, or 000.

Termination from ECP Mode

Termination from ECP Mode is similar to the termination from Nibble/Byte Modes. The host is permitted to terminate from ECP Mode only in specific well-defined states. The termination can only be executed while the bus is in the forward direction. To terminate while the channel is in the reverse direction, it must first be transitioned into the forward direction.

Command/Data

ECP Mode supports two advanced features to improve the effectiveness of the protocol for some applications. The features are implemented by allowing the transfer of normal 8 bit data or 8 bit commands.

When in the forward direction, normal data is transferred when HostAck is high and an 8 bit command is transferred when HostAck is low.

The most significant bit of the command indicates whether it is a run-length count (for compression) or a channel address.

When in the reverse direction, normal data is transferred when PeriphAck is high and an 8 bit command is transferred when PeriphAck is low. The most significant bit of the command is always zero. Reverse channel addresses are seldom used and may not be supported in hardware.

Table 9.9 – ECP Forward/Reverse Channel Commands

Forward Channel Commands (HostAck Low)	
Reverse Channel Commands (PeriphAck Low)	
D7	D[6:0]
0	Run-Length Count (0-127) (mode 0011 0X00 only)
1	Channel Address (0-127)

Data Compression

The ECP port supports run length encoded (RLE) decompression in hardware and can transfer compressed data to a peripheral. Run length encoded (RLE) compression in hardware is not supported. To transfer compressed data in ECP mode, the compression count is written to the ecpAFifo and the data byte is written to the ecpDFifo.

Compression is accomplished by counting identical bytes and transmitting an RLE byte that indicates how many times the next byte is to be repeated. Decompression simply intercepts the RLE byte and repeats the following byte the specified number of times. When a run-length count is received from a peripheral, the subsequent data byte is replicated the specified number of times. A run-length count of zero specifies that only one byte of data is represented by the next data byte, whereas a run-length count of 127 indicates that the next byte should be expanded to 128 bytes. To prevent data expansion, however, run-length counts of zero should be avoided.

Pin Definition

The drivers for nStrobe, nAutoFd, nInIt and nSelectIn are open-drain in mode 000 and are push-pull in all other modes.

LPC Connections

The interface can never stall causing the host to hang. The width of data transfers is strictly controlled on an I/O address basis per this specification. All FIFO-DMA transfers are byte wide, byte aligned and end on a byte boundary. (The PWord value can be obtained by reading Configuration Register A, crfgA, described in the next section). Single byte wide transfers are always possible with standard or PS/2 mode using program control of the control signals.

Interrupts

The interrupts are enabled by `serviceIntr` in the `ecr` register.

`serviceIntr = 1` Disables the DMA and all of the service interrupts.

`serviceIntr = 0` Enables the selected interrupt condition. If the interrupting condition is valid, then the interrupt is generated immediately when this bit is changed from a 1 to a 0. This can occur during Programmed I/O if the number of bytes removed or added from/to the FIFO does not cross the threshold.

An interrupt is generated when:

1. For DMA transfers: When `serviceIntr` is 0, `dmaEn` is 1 and the DMA TC cycle is received.
2. For Programmed I/O:
 - a) When `serviceIntr` is 0, `dmaEn` is 0, `direction` is 0 and there are `writeIntrThreshold` or more free bytes in the FIFO. Also, an interrupt is generated when `serviceIntr` is cleared to 0 whenever there are `writeIntrThreshold` or more free bytes in the FIFO.
 - b) When `serviceIntr` is 0, `dmaEn` is 0, `direction` is 1 and there are `readIntrThreshold` or more bytes in the FIFO. Also, an interrupt is generated when `serviceIntr` is cleared to 0 whenever there are `readIntrThreshold` or more bytes in the FIFO.
3. When `nErrIntrEn` is 0 and `nFault` transitions from high to low or when `nErrIntrEn` is set from 1 to 0 and `nFault` is asserted.
4. When `ackIntEn` is 1 and the `nAck` signal transitions from a low to a high.

FIFO Operation

The FIFO threshold is set in the chip configuration registers. All data transfers to or from the parallel port can proceed in DMA or Programmed I/O (non-DMA) mode as indicated by the selected mode. The FIFO is used by selecting the Parallel Port FIFO mode or ECP Parallel Port Mode. (FIFO test mode will be addressed separately.) After a reset, the FIFO is disabled. Each data byte is transferred by a Programmed I/O cycle or DMA cycle depending on the selection of DMA or Programmed I/O mode.

The following paragraphs detail the operation of the FIFO flow control. In these descriptions, `<threshold>` ranges from 1 to 16. The parameter `FIFOTHR`, which the user programs, is one less and ranges from 0 to 15.

A low threshold value (i.e. 2) results in longer periods of time between service requests, but requires faster servicing of the request for both read and write cases. The host must be very responsive to the service request. This is the desired case for use with a "fast" system. A high value of threshold (i.e. 12) is used with a "sluggish" system by affording a long latency period after a service request, but results in more frequent service requests.

DMA Transfers

DMA transfers are always to or from the `ecpDFifo`, `tFifo` or `CFifo`. DMA utilizes the standard PC DMA services. To use the DMA transfers, the host first sets up the direction and state as in the programmed I/O case. Then it programs the DMA controller in the host with the desired count and memory address. Lastly it sets `dmaEn` to 1 and `serviceIntr` to 0. The ECP requests DMA transfers from the host by encoding the `nLDRQ` pin. The DMA will empty or fill the FIFO using the appropriate direction and mode. When the terminal count in the DMA controller is reached, an interrupt is generated and `serviceIntr` is asserted,

disabling DMA. In order to prevent possible blocking of refresh requests a DMA cycle shall not be requested for more than 32 DMA cycles in a row. The FIFO is enabled directly by the host initiating a DMA cycle for the requested channel, and addresses need not be valid. An interrupt is generated when a TC cycle is received. (Note: The only way to properly terminate DMA transfers is with a TC cycle.)

DMA may be disabled in the middle of a transfer by first disabling the host DMA controller. Then setting `serviceIntr` to 1, followed by setting `dmaEn` to 0, and waiting for the FIFO to become empty or full. Restarting the DMA is accomplished by enabling DMA in the host, setting `dmaEn` to 1, followed by setting `serviceIntr` to 0.

DMA Mode - Transfers from the FIFO to the Host

Note: In the reverse mode, the peripheral may not continue to fill the FIFO if it runs out of data to transfer, even if the chip continues to request more data from the peripheral.

The ECP requests a DMA cycle whenever there is data in the FIFO. The DMA controller responds to the request by reading data from the FIFO. The ECP stop requesting DMA cycles when the FIFO becomes empty or when a TC cycle is received, indicating that no more data is required. If the ECP stops requesting DMA cycles due to the FIFO going empty, then a DMA cycle is requested again as soon as there is one byte in the FIFO. If the ECP stops requesting DMA cycles due to the TC cycle, then a DMA cycle is requested again when there is one byte in the FIFO, and `serviceIntr` has been re-enabled.

Programmed I/O Mode or Non-DMA Mode

The ECP or parallel port FIFOs may also be operated using interrupt driven programmed I/O. Software can determine the `writeIntrThreshold`, `readIntrThreshold`, and FIFO depth by accessing the FIFO in Test Mode.

Programmed I/O transfers are to the `ecpDFifo` at 400H and `ecpAFifo` at 000H or from the `ecpDFifo` located at 400H, or to/from the `tFifo` at 400H. To use the programmed I/O transfers, the host first sets up the direction and state, sets `dmaEn` to 0 and `serviceIntr` to 0.

The ECP requests programmed I/O transfers from the host by activating the interrupt. The programmed I/O will empty or fill the FIFO using the appropriate direction and mode.

Note: A threshold of 16 is equivalent to a threshold of 15. These two cases are treated the same.

Programmed I/O - Transfers from the FIFO to the Host

In the reverse direction an interrupt occurs when `serviceIntr` is 0 and `readIntrThreshold` bytes are available in the FIFO. If at this time the FIFO is full it can be emptied completely in a single burst, otherwise `readIntrThreshold` bytes may be read from the FIFO in a single burst.

`readIntrThreshold` = (16 - <threshold>) data bytes in FIFO

An interrupt is generated when `serviceIntr` is 0 and the number of bytes in the FIFO is greater than or equal to (16 - <threshold>). (If the threshold = 12, then the interrupt is set whenever there are 4-16 bytes in the FIFO). The host must respond to the request by reading data from the FIFO. This process is repeated until the last byte is transferred out of the FIFO. If at this time the FIFO is full, it can be completely emptied in a single burst, otherwise a minimum of (16 - <threshold>) bytes may be read from the FIFO in a single burst.

Programmed I/O - Transfers from the Host to the FIFO

In the forward direction an interrupt occurs when serviceIntr is 0 and there are writeIntrThreshold or more bytes free in the FIFO. At this time if the FIFO is empty it can be filled with a single burst before the empty bit needs to be re-read. Otherwise it may be filled with writeIntrThreshold bytes.

writeIntrThreshold = (16-<threshold>) free bytes in FIFO

An interrupt is generated when serviceIntr is 0 and the number of bytes in the FIFO is less than or equal to <threshold>. (If the threshold = 12, then the interrupt is set whenever there are 12 or less bytes of data in the FIFO.) The host must respond to the request by writing data to the FIFO. If at this time the FIFO is empty, it can be completely filled in a single burst, otherwise a minimum of (16-<threshold>) bytes may be written to the FIFO in a single burst. This process is repeated until the last byte is transferred into the FIFO.

Chapter 10 Power Management

Power management capabilities are provided for the following logical devices: UART and the parallel port. For each logical device, two types of power management are provided: direct powerdown and auto powerdown.

10.1 UART Power Management

Direct power management is controlled by CR02. Refer to the Configuration section for more information.

Auto Power Management is enabled by the UART enable bit in CR07. When set, the bit allow the following auto power management operations:

1. The transmitter enters auto powerdown when the transmit buffer and shift register are empty.
2. The receiver enters powerdown when the following conditions are all met:
 - a) Receive FIFO is empty
 - b) The receiver is waiting for a start bit.

Note: While in powerdown the Ring Indicator interrupt is still valid and transitions when the RI input changes.

10.1.1 Exit Auto Powerdown

The transmitter exits powerdown on a write to the XMIT buffer. The receiver exits auto powerdown when RXDx changes state.

10.2 Parallel Port Power Management

Direct power management is controlled by Bit[2] in CR01. Refer to the Configuration section for more information.

Auto Power Management is enabled by Bit[4] in CR07 . When set, this bit allows the ECP or EPP logical parallel port blocks to be placed into powerdown when not being used.

The EPP logic is in powerdown under any of the following conditions:

1. EPP is not enabled in the configuration registers.
2. EPP is not selected through ecr while in ECP mode.

The ECP logic is in powerdown under any of the following conditions:

1. ECP is not enabled in the configuration registers.
2. SPP, PS/2 Parallel port or EPP mode is selected through ecr while in ECP mode.

10.2.1 Exit Auto Powerdown

The parallel port logic can change powerdown modes when the ECP mode is changed through the ecr register or when the parallel port mode is changed through the configuration registers.

Chapter 11 Serial IRQ

The LPC47N237 supports the serial interrupt to transmit interrupt information to the host system. The serial interrupt scheme adheres to the Serial IRQ Specification for PCI Systems, Version 6.0. The PCI_CLK, SER_IRQ and nCLKRUN pins are used for this interface. The Serial IRQ/CLKRUN Enable bit D7 in CR29 activates the serial interrupt interface.

11.1 Timing Diagrams For SER_IRQ Cycle

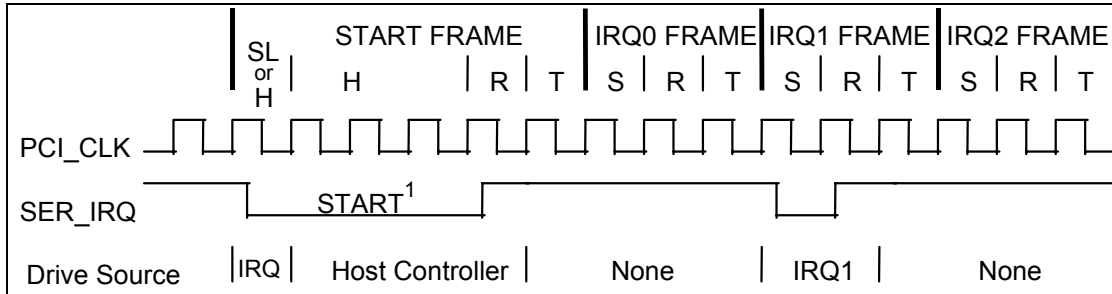

Figure 11.1 A. Start Frame timing with source sampled a low pulse on IRQ1

Note: H=Host Control; R=Recovery; T=Turn-Around; SL=Slave Control; S=Sample

Note 1: Start Frame pulse can be 4-8 clocks wide depending on the location of the device in the PCI bridge hierarchy in a synchronous bridge design.

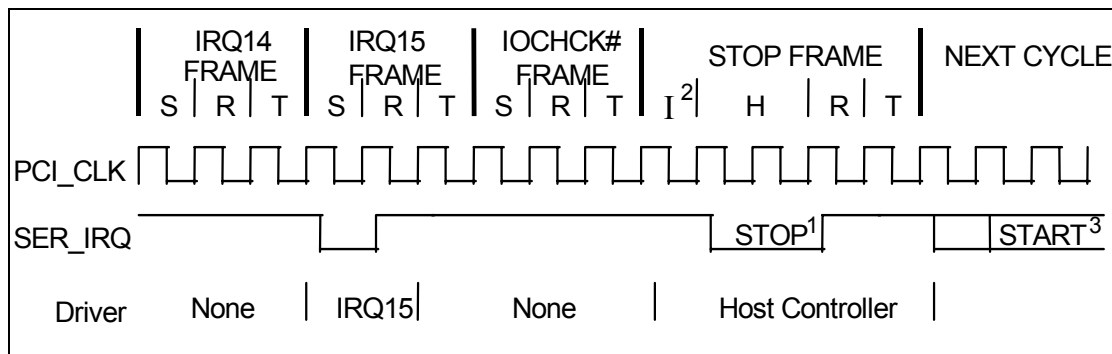

Figure 11.2 B. Stop Frame Timing with Host using 17 SER_IRQ sampling period

Note: H=Host Control; R=Recovery; T=Turn-Around; S=Sample; I=Idle

Note 1: Stop pulse is 2 clocks wide for Quiet mode, 3 clocks wide for Continuous mode.

Note 2: There may be none, one or more Idle states during the Stop Frame.

Note 3: The next SER_IRQ cycle's Start Frame pulse may or may not start immediately after the turn-around clock of the Stop Frame.

11.1.1 SER_IRQ Cycle Control

There are two modes of operation for the SER_IRQ Start Frame.

1. **Quiet (Active) Mode:** Any device may initiate a Start Frame by driving the SER_IRQ low for one clock, while the SER_IRQ is Idle. After driving low for one clock the SER_IRQ is immediately tri-stated without at any time driving high. A Start Frame may not be initiated while the SER_IRQ is Active. The SER_IRQ is Idle between Stop and Start Frames. The SER_IRQ is Active between Start and Stop Frames. This mode of operation allows the SER_IRQ to be Idle when there are no IRQ/Data transitions which should be most of the time.

Once a Start Frame has been initiated the Host Controller will take over driving the SER_IRQ low in the next clock and will continue driving the SER_IRQ low for a programmable period of three to seven clocks. This makes a total low pulse width of four to eight clocks. Finally, the Host Controller will drive the SER_IRQ back high for one clock, then tri-state.

Any SER_IRQ Device (i.e., The LPC47N237) which detects any transition on an IRQ/Data line for which it is responsible must initiate a Start Frame in order to update the Host Controller unless the SER_IRQ is already in an SER_IRQ Cycle and the IRQ/Data transition can be delivered in that SER_IRQ Cycle.

2. **Continuous (Idle) Mode:** Only the Host controller can initiate a Start Frame to update IRQ/Data line information. All other SER_IRQ agents become passive and may not initiate a Start Frame. SER_IRQ will be driven low for four to eight clocks by Host Controller. This mode has two functions. It can be used to stop or idle the SER_IRQ or the Host Controller can operate SER_IRQ in a continuous mode by initiating a Start Frame at the end of every Stop Frame.

An SER_IRQ mode transition can only occur during the Stop Frame. Upon reset, SER_IRQ bus is defaulted to Continuous mode, therefore only the Host controller can initiate the first Start Frame. Slaves must continuously sample the Stop Frames pulse width to determine the next SER_IRQ Cycle's mode.

11.1.2 SER_IRQ Data Frame

Once a Start Frame has been initiated, the LPC47N237 will watch for the rising edge of the Start Pulse and start counting IRQ/Data Frames from there. Each IRQ/Data Frame is three clocks: Sample phase, Recovery phase, and Turn-around phase. During the Sample phase the LPC47N237 drives the SER_IRQ low, if and only if, its last detected IRQ/Data value was low. If its detected IRQ/Data value is high, SER_IRQ is left tri-stated. During the Recovery phase the LPC47N237 drives the SER_IRQ high, if and only if, it had driven the SER_IRQ low during the previous Sample Phase. During the Turn-around Phase the LPC47N237 tri-states the SER_IRQ. The LPC47N237 will drive the SER_IRQ line low at the appropriate sample point if its associated IRQ/Data line is low, regardless of which device initiated the Start Frame.

The Sample Phase for each IRQ/Data follows the low to high transition of the Start Frame pulse by a number of clocks equal to the IRQ/Data Frame times three, minus one. (e.g. The IRQ5 Sample clock is the sixth IRQ/Data Frame, $(6 \times 3) - 1 = 17$ th clock after the rising edge of the Start Pulse).

Table 11.1 - SER_IRQ Sampling Periods

SER_IRQ PERIOD	SIGNAL SAMPLED	# OF CLOCKS PAST START
1	Not Used	2
2	IRQ1	5
3	IRQ2	8
4	IRQ3	11
5	IRQ4	14

SER_IRQ PERIOD	SIGNAL SAMPLED	# OF CLOCKS PAST START
6	IRQ5	17
7	IRQ6	20
8	IRQ7	23
9	IRQ8	26
10	IRQ9	29
11	IRQ10	32
12	IRQ11	35
13	IRQ12	38
14	IRQ13	41
15	IRQ14	44
16	IRQ15	47

SER_IRQ Period 14 is used to transfer IRQ13. Logical devices Parallel Port and Serial Port have IRQ13 as a choice for their primary interrupt.

11.1.3 Stop Cycle Control

Once all IRQ/Data Frames have completed the Host Controller will terminate SER_IRQ activity by initiating a Stop Frame. Only the Host Controller can initiate the Stop Frame. A Stop Frame is indicated when the SER_IRQ is low for two or three clocks. If the Stop Frame's low time is two clocks then the next SER_IRQ Cycle's sampled mode is the Quiet mode; and any SER_IRQ device may initiate a Start Frame in the second clock or more after the rising edge of the Stop Frame's pulse. If the Stop Frame's low time is three clocks then the next SER_IRQ Cycle's sampled mode is the Continuous mode; and only the Host Controller may initiate a Start Frame in the second clock or more after the rising edge of the Stop Frame's pulse.

11.1.4 Latency

Latency for IRQ/Data updates over the SER_IRQ bus in bridge-less systems with the minimum Host supported IRQ/Data Frames of seventeen, will range up to 96 clocks (3.84 μ S with a 25MHz PCI Bus or 2.88 μ S with a 33MHz PCI Bus). If one or more PCI to PCI Bridge is added to a system, the latency for IRQ/Data updates from the secondary or tertiary buses will be a few clocks longer for synchronous buses, and approximately double for asynchronous buses.

11.1.5 EOI/ISR Read Latency

Any serialized IRQ scheme has a potential implementation issue related to IRQ latency. IRQ latency could cause an EOI or ISR Read to precede an IRQ transition that it should have followed. This could cause a system fault. The host interrupt controller is responsible for ensuring that these latency issues are mitigated. The recommended solution is to delay EOIs and ISR Reads to the interrupt controller by the same amount as the SER_IRQ Cycle latency in order to ensure that these events do not occur out of order.

11.1.6 AC/DC Specification Issue

All SER_IRQ agents must drive / sample SER_IRQ synchronously related to the rising edge of PCI bus clock. The SER_IRQ pin uses the electrical specification of PCI bus. Electrical parameters will follow PCI spec. section 4, sustained tri-state.

11.1.7 Reset and Initialization

The SER_IRQ bus uses nPCI_RESET as its reset signal. The SER_IRQ pin is tri-stated by all agents while nPCI_RESET is active. With reset, SER_IRQ Slaves are put into the (continuous) IDLE mode. The Host Controller is responsible for starting the initial SER_IRQ Cycle to collect system's IRQ/Data default values. The system then follows with the Continuous/Quiet mode protocol (Stop Frame pulse width) for subsequent SER_IRQ Cycles. It is Host Controller's responsibility to provide the default values to 8259's and other system logic before the first SER_IRQ Cycle is performed. For SER_IRQ system suspend, insertion, or removal application, the Host controller should be programmed into Continuous (IDLE) mode first. This is to guarantee SER_IRQ bus is in IDLE state before the system configuration changes.

Chapter 12 PCI CLKRUN Support

12.1 Overview

The LPC47N237 supports the PCI nCLKRUN signal. nCLKRUN is used to indicate the PCI clock status as well as to request that a stopped clock be started. Figure 12.1 for an example of a typical system implementation using nCLKRUN.

If the LPC47N237 SIRQ_CLKRUN_EN signal is disabled, it will disable the nCLKRUN support related to nLDRQ in addition to disabling the SER_IRQ and the nCLKRUN associated with SER_IRQ.

nCLKRUN is an open drain output and an input. Refer to the *PCI Mobile Design Guide Rev 1.0* for a description of the nCLKRUN function.

12.2 nCLKRUN for Serial IRQ

The LPC47N237 supports the PCI nCLKRUN signal for the Serial IRQs. If an SIO interrupt occurs while the PCI clock is stopped, nCLKRUN is asserted before the serial interrupt signal is driven active.

See “Using nCLKRUN” section below for more details.

12.3 nCLKRUN for nLDRQ

nCLKRUN support is also provided in the LPC47N237 for the nLDRQ signal. If a device requests DMA service while the PCI clock is stopped, nCLKRUN is asserted to restart the PCI clock. This is required to drive the nLDRQ signal active.

See “Using nCLKRUN” section for more details.

12.4 Using nCLKRUN

If nCLKRUN is sampled “high”, the PCI clock is stopped or stopping. If nCLKRUN is sampled “low”, the PCI clock is starting or started (running). If a device in the LPC47N237 asserts or de-asserts an interrupt or asserts a DMA request, and nCLKRUN is sampled “high”, the LPC47N237 requests the restoration of the clock by asserting the nCLKRUN signal asynchronously (Figure 12.2). The LPC47N237 holds nCLKRUN low until it detects two rising edges of the clock. After the second clock edge, the LPC47N237 disables the open drain driver (Figure 12.2).

The LPC47N237 will not assert nCLKRUN under any conditions if SIRQ_CLKRUN_EN is inactive (“0”). The SIRQ_CLKRUN_EN bit is D7 in CR29.

The LPC47N237 will not assert nCLKRUN if it is already driven low by the central resource; i.e., the PCI CLOCK GENERATOR in Figure 12.1. The LPC47N237 will not assert nCLKRUN unless the line has been deasserted for two successive clocks; i.e., before the clock was stopped (Figure 12.2).

Table 12.1 – LPC47N237 nCLKRUN Function

SIRQ_CLKRUN_EN	INTERNAL INTERRUPTS/ DMA REQUESTS	NCLKRUN	ACTION
0	X	X	None
1	NO CHANGE	X	None
	CHANGE/ASSERTION (Note 12.1)	0	None
		1	Assert nCLKRUN (Note 12.2)

Note 12.1 “Change/Assertion” means either-edge change on any internal IRQs routed to the SIRQ block or assertion of an internal DMA request by a device in LPC47N237. The “assertion” detection logic runs asynchronously to the PCI Clock and regardless of the Serial IRQ mode; i.e., “continuous” or “quiet”.

Note 12.2 The nCLKRUN signal is ‘1’ for at least two consecutive clocks before LPC47N237 asserts (‘0’) it.

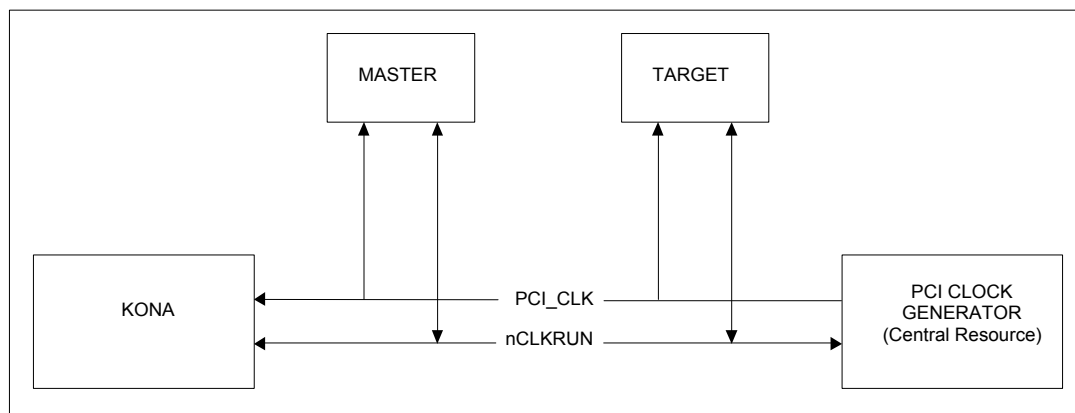
**Figure 12.1 – nCLKRUN System Implementation Example**

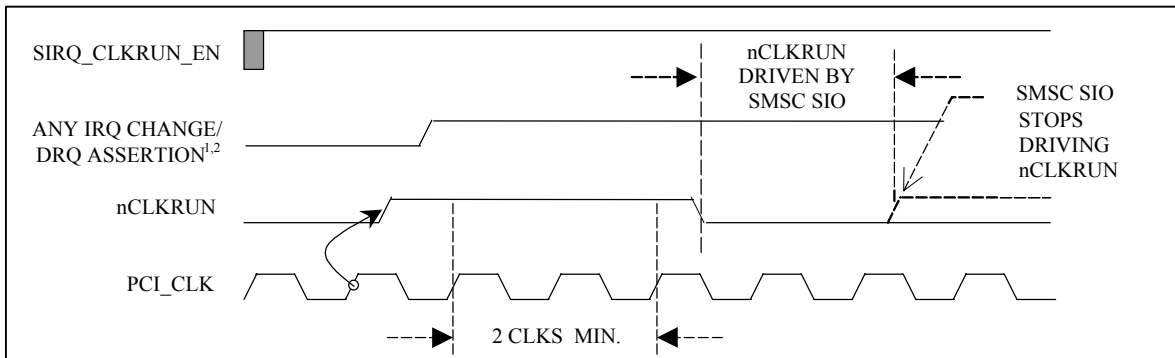
Figure 12.2 – Clock Start Illustration

Note 12.3 The signal “ANY IRQ CHANGE/DRQ ASSERTION” is the same as “CHANGE/ASSERTION” in Table 12.1.

Note 12.4 The LPC47N237 continually monitors the state of nCLKRUN to maintain the PCI Clock until an active “ANY IRQ CHANGE/DRQ ASSERTION” condition has been transferred to the host in a SER_IRQ/DMA cycle. For example, if “ANY IRQ CHANGE/DRQ ASSERTION” is asserted before nCLKRUN is de-asserted (not shown in Figure 12.2), the LPC47N237 will assert nCLKRUN as needed until the SER_IRQ/DMA cycle has completed.

Chapter 13 LPC General Purpose I/O

The LPC47N237 provides a set of flexible Input/Output control functions to the system designer through the 4 independently programmable LPC controlled General Purpose I/O pins (LGP44-LGP47). The LPC GPIOs are VCC powered and are not available under VTR power only.

13.1 Description

Each LPC GPIO port has a 1-bit data register. GPIOs are controlled by GPIO control registers located in the Configuration section. The data register for each GPIO port is represented as a bit in one of the 8-bit GPIO DATA Register, LGP_DATA. The bits in the registers reflect the value of the associated GPIO pin as follows. Pin is an input: The bit is the value of the GPIO pin. Pin is an output: The value written to the bit goes to the GPIO pin. Latched on read and write. The GPIO data registers are located in the Runtime Register block; see the Runtime Registers section.

Table 13.1 – General Purpose I/O Port Assignments

DEFAULT FUNCTION	DATA REGISTER (NOTE 13.1)	DATA REGISTER BIT NO.	REGISTER OFFSET (HEX)
Reserved	LGP_DATA	0	02
Reserved		1	
Reserved		2	
Reserved		3	
LGP44		4	
LGP45		5	
LGP46		6	
LGP47		7	

Note 13.1 The GPIO Data Registers are located at the offset shown from the RUNTIME REGISTERS BLOCK address.

13.2 GPIO Control

Each GPIO port has an 8-bit control register that controls the behavior of the pin. This register is defined in the Configuration section of this specification.

Each GPIO port may be configured as either an input or an output. If the pin is configured as an output, it will be push-pull. Inputs and outputs can be configured as non-inverting or inverting. LPC GPIO Direction Register determine the port direction and LPC GPIO Polarity Register determine the signal polarity.

The basic GPIO configuration options are summarized in Table 13.2.

Table 13.3 – GPIO Read/Write Behavior

HOST OPERATION	GPIO INPUT PORT	GPIO OUTPUT PORT
READ	LATCHED VALUE OF GPIO PIN	LAST WRITE TO GPIO DATA REGISTER
WRITE	NO EFFECT	BIT PLACED IN GPIO DATA REGISTER

Chapter 14 PME Support

The LPC47N237 offers support for Power Management Events (PMEs), also referred to as System Control Interrupt (SCI) events in an ACPI system. A power management event is indicated to the chipset via the assertion of the nIO_PME signal. In the LPC47N237, the nIO_PME is asserted by active transitions on the ring indicator inputs nRI pin. The nIO_PME pin can be programmed to be active high or active low via bit 6 in the nIO_PME Output Type and Polarity register (CR39). The nIO_PME pin function defaults to active low, open-drain output. The output buffer type of the pin can be programmed to be open-drain or push-pull via bit 7 in the CR39. This pin is powered by VTR. See the Configuration section for description on CR39 register.

Ring Indicate PME functionality is controlled by the RI_PME_Status and RI_PME_EN bits in the PME_STS and PME_EN registers respectively. These registers are located in the Runtime Registers Block. The status bit is set on high-to-low transitions on the nRI pin. If the enable bit is set and if the status bit is set, the nIO_PME will be active low for Ring Indicate wake event.

The nIO_PME pin can be programmed to be an open drain, active low, driver. The LPC47N237 nIO_PME pin is fully isolated from other external devices that might pull the nIO_PME signal low; i.e., the nIO_PME signal is capable of being driven high externally by another active device or pullup even when the LPC47N237 VCC is grounded, providing VTR power is active.

Chapter 15 SMBus GPIO Block

- The SMBus GPIO block is a standalone block and consists into two blocks:
 - SMBus Slave Controller
 - SMBus Controlled GPIO Block
- The SMBus GPIOs will be accessed via the SMBus interface. There will be no LPC Host access to the GPIOs in the SMBus GPIO Block.
- The SMBus controller and the GPIO block is powered by VTR.

SMBus Isolation Circuitry controls the connection of up to two devices to the SMBus. Two pairs of SMBus pins (SCLK_1/SDAT_1, SCLK_2/SDAT_2) are individually software selectable to connect internally to the SCLK and SDAT pins.

See the sub sections below for description on SMBus Slave Controller and the SMBus Controlled GPIO Block.

15.1 SMBus Slave Controller

The host processor communicates with the LPC47N237 through a series of read/write registers via the SMBus interface. SMBus is a serial communication protocol between a computer host and its peripheral devices.

The default power on SMBus address is 010010x binary, where x reflects the state defined by the SMB_A0 pin.

The LPC47N237 SMBus implementation is a subset of the SMBus interface to the host. The SMBus Controller Block is a *slave-only* SMBus device. The implementation in the LPC47N237 is a subset of SMBus since it only supports two protocols.

The Read Byte and Write Byte protocols are the only valid SMBus protocols for the LPC47N237. The part responds to other protocols as described in the “Invalid Protocol Response Behavior” Section. Reference the System Management Bus Specification, Rev 1.1.

The SMBus interface is used to read and write the registers in the LPC47N237. The only valid registers for a read or write protocol are the registers shown in the “SMBus GPIO Register”.

15.1.1 SMBus Pins

Table 15.1 shows the SMBus pins.

Table 15.1 – SMBus Pins

PIN NAME	TYPE	PWR WELL	DESCRIPTION
SMB_A0	I	VTR	SMBus LSB address pin with
SCLK	IOD	VTR	SMBus Clock IOD
SDAT	IOD	VTR	SMBus Data IOD
nSMBINT	OD	VTR	Active low SMBus Interrupt Open-Drain output
SCLK_1	IOD	VTR	SMBus Clock IOD
SDAT_1	IOD	VTR	SMBus Data IOD
SCLK_2	IOD	VTR	SMBus Clock IOD
SDAT_2	IOD	VTR	SMBus Data IOD

15.1.2 Bus Protocols

Typical Write Byte, Read Byte protocols are shown below. Register accesses are performed using 7-bit slave addressing, an 8-bit register address field, and an 8-bit data field. The shading indicates the LPC47N237 driving data on the SDAT line; otherwise host data is on the SDAT line.

The slave address is the unique SMBus Interface Address for the LPC47N237 that identifies it on SMBus. The register address field is the internal address of the register to be accessed. The register data field is the data that the host is attempting to write to the register or the contents of the register that the host is attempting to read.

Data bytes are transferred MSB first.

When using the LPC47N237 SMBus Interface, a read and write will always consist of the SMBus Interface Address byte, followed by the Register Address byte, then the data byte.

Write Byte

The Write Byte protocol is used to write data to the registers. The data will only be written if the protocol shown in Table 15.2 is performed correctly. Only one byte is transferred at time for a Write Byte protocol.

Table 15.2 – SMBus Write Byte Protocol

Field:	Start	Slave Addr	Wr	Ack	Reg. Addr	Ack	Reg. Data	Ack	Stop
Bits:	1	7	1	1	8	1	8	1	1

Read Byte

The Read Byte protocol is used to read data from the registers. The data will only be read if the protocol shown in Table 15.3 is performed correctly. Only one byte is transferred at time for a Read Byte protocol.

Table 15.3 – SMBus Read Byte Protocol

Field:	Start	Slave Addr	Wr	Ack	Reg. Addr	Ack	Start	Slave Addr	Rd	Ack	Reg. Data	Nack	Stop
Bits:	1	7	1	1	8	1	1	7	1	1	8	1	1

15.1.3 Slave Address

The slave address is the unique address for the LPC47N237 that identifies the device on SMBus.

The LPC47N237 slave address is determined by the level on the SMB_A0 pin on a VTR POR. The level on this pin forms the LSB of the 7-bit address 010010x, where x is the state of the SMB_A0 on VTR POR. This pin may be used to support up to 2 of these devices in a given system.

The upper 6 bits of the LPC47N237's slave address are hardwired in the LPC47N237.

15.1.4 Invalid Protocol Response Behavior

Registers that are accessed with an invalid protocol will not be updated. A register will only be updated following a valid protocol. The only valid protocols are the read byte, receive byte and write byte protocols described above.

The only valid slave address is determined by the level on the SMB_A0 pin as the LSB of the address 010010x.

The only valid registers for a read or write protocol are the registers shown in the Registers Section. Reserved registers are not considered valid registers.

Attempting to communicate with the LPC47N237 over SMBus with an invalid slave address, invalid register address or invalid protocol will result in no response, and the SMBus Slave Interface will return to the idle state.

15.1.5 General Call Address Response

The LPC47N237 will not respond to a general call address of 0000 000.

15.1.6 Slave Device Time-Out

The device will time-out when SCLK is held low for 25ms-35ms. The SMBus slave interface resets and returns to idle by 35msec.

15.1.7 Stretching the SCLK Signal

The LPC47N237 supports stretching of the SCLK by other devices on the SMBus. The LPC47N237 does not stretch the SCLK.

15.1.8 SMBus Timing

The SMBus Slave Interface complies with the SMBus AC Timing Specification. See the SMBus timing in "Timing Diagrams" section.

15.1.9 Bus Reset Sequence

The SMBus Slave Interface will reset and return to the idle state upon a START field followed immediately by a STOP field.

15.1.10 SMBus Alert Response

The LPC47N237 does not implement the nSMBALERT response.

15.2 SMBus Isolation Logic

The SMBus Isolation Circuitry is used to control the connection of up to two devices to the SMBus. The two pairs of SMBus pins (SCLK_1/SDAT_1, SCLK_2/SDAT_2) are individually software selectable to connect internally to SMBus. The selection allows for the two SMBus devices to be disconnected, individually connected (one or the other) or both connected to SMBus.

Note that the SMBus slave device (GPIO Controller) in the part is always connected to the SMBus via the SCLK/SDAT pins.

When one of the pairs of SCLK_1/SDAT_1 or SCLK_2/SDAT_2 pins are selected, the SMBus signals from/to the SCLK/SDAT pins and the internal SMBus Slave device are passed through to/from the selected SMBus pair. When both pairs are selected, then these devices can also communicate with each other.

The SMBus Isolation Logic is implemented as a switch that internally connects neither, one or the other or both devices to the SMBus as selected through the bits defined below.

The following bits are used to select the SMBus device to be isolated from the SMBus. The SMBus Isolation register at 0x0E holds these bits.

Bits[1:0]: These bits control which pair of SMBus pins (SCLK_1/SDAT_1, SCLK_2/SDAT_2) are connected to the SMBus.

00 = Both SMBus devices isolated from SMBus (default). In this case, both device 1 and device 2 are isolated from the internal SMBus slave device and all external SMBus devices (including each other).

01 = SCLK_1/SDAT_1 connected to SCLK/SDAT. In this case, device 1 can communicate with the internal SMBus slave device and any external slave devices on SMBus (excluding device 2).

10 = SCLK_2/SDAT_2 connected to SCLK/SDAT. In this case, device 2 can communicate with the internal SMBus slave device and any external slave devices on SMBus (excluding device 1).

11 = Both SMBus devices connected to SMBus. In this case, device 1 and device 2 can communicate with the internal SMBus slave device and any external slave devices on SMBus (including each other).

Bits[7:2] are reserved.

The following figure shows a representation of the switch in the system.

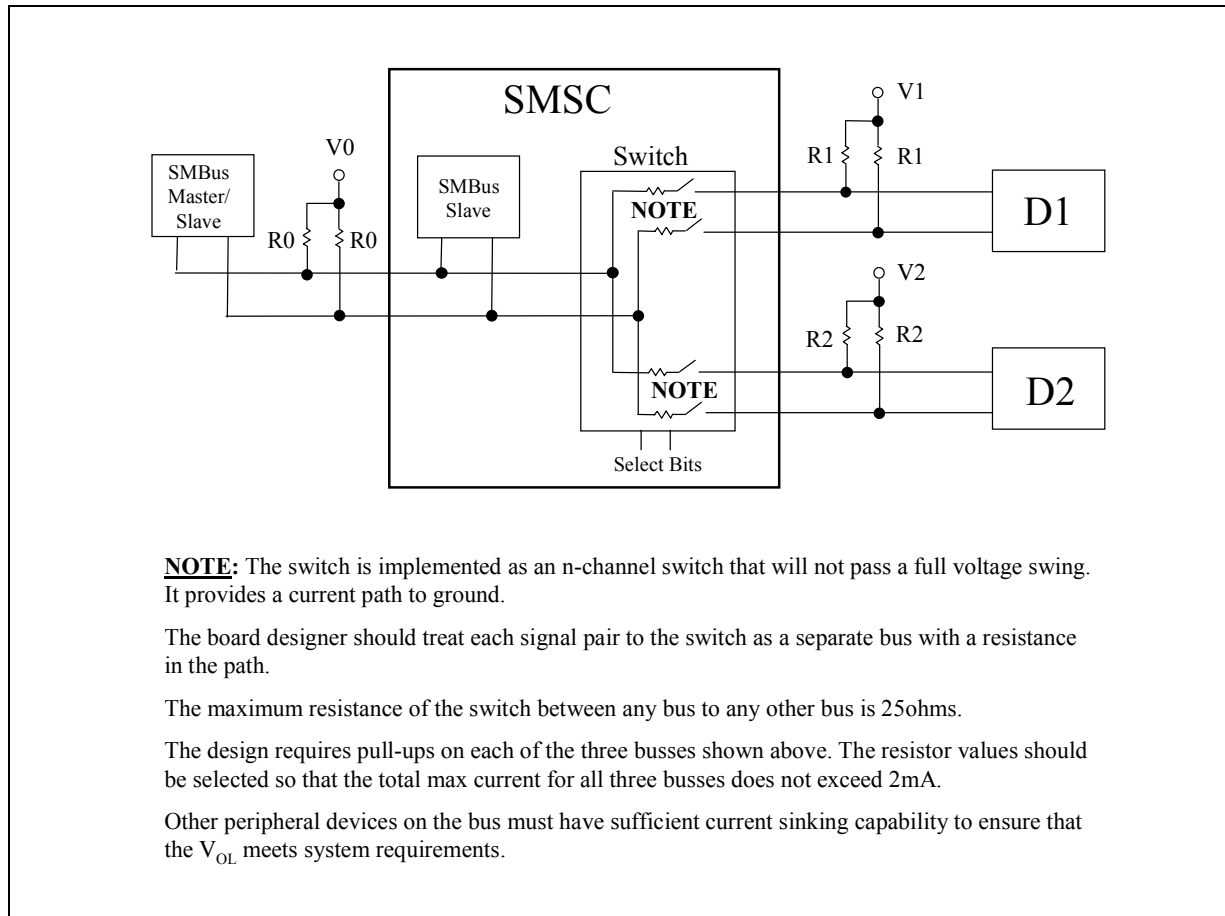

Figure 15.1 – SMBus Isolation Switch

The following gives some sample values of pull-up resistor values to the following voltages: $V_0=5V$, $V_1=3.3V$, $V_2=5V$ (refer to the figure above).

	Total Current for all three busses =2mA max	Total Current for all three busses = 350uA max
R0	7k	35k
R1	6k	25k
R2	9k	45k

The estimated max capacitance is 35pf into the SDAT/SCLK pins and 30pF into the SDAT_1,2/SCLK_1,2 pins.

15.3 SMBus Controlled GPIOs

SMBus GPIO summary:

- 32 GPIO pins
- Pins and Registers Powered by VTR. All SMBus GPIOs can drive under VTR power.
- Wake on Change – set the status bit on both a high-to-low and a low-to-high edge. Assert nSMBINT pin if associated mask bit is set.

- 4 Direction Registers
- 4 Output Type Registers
- 4 Data Registers
- 4 Mask Registers
- 1 Change Status Register

15.3.1 GPIO Pins

Table 15.4 shows the SMBus GPIOs pins.

- These pins are powered by VTR
- These pins sink 8mA and source 4 mA current under VTR power.
- The default on these pins will be input on VTR POR in the LPC47N237.

Table 15.4 – SMBus GPIO Pins

PIN NAME	BUFFER	PWR WELL	DESCRIPTION
GP10 – GP17, GP20 – GP27, GP30 – GP37, GP50 – GP57	IO8	VTR	General Purpose I/O

15.4 SMBus GPIO Registers

See the following sub section for functionality of the SMBus GPIO registers. These registers are in the SMBus runtime register space and are listed in the “SMBus GPIO Register Map” section.

15.4.1 Direction Registers

There are four direction registers containing bits for each GPIO pin. The Direction register is used to select input or output direction on the GPIO pin.

15.4.2 Output Type Registers

There are four output type registers containing bits for each GPIO pin. The output type register is used to selection whether the GPIO pin will be push-pull or open-drain.

15.4.3 Data Registers

The data register will reflect the state of the GPIO input if the GP pin is used as input. It is used to set the state of the GPIO pin when the GPIO is used as output.

15.4.4 GPIO Mask Registers

There are four mask registers containing bits for each GPIO pin. The bits in the Mask registers are used to enable/disable wakeup events on the Change Status register. See the “GPIO Change Status Register” section for more information.

15.4.5 GPIO Change Status Register

There are four bits in the change status register – one for each data register. The change status register is used to indicate whether any of the data register bits (if GPIO is programmed as an input and unmasked) has changed state since the last read of the data register. The change status register bit is cleared on the read of the corresponding data register. See the “SMBus GPIO Register” section and “Operation of SMBus Interrupt” section.

If any of the bits in this register is set to ‘1’, the nSMBINT pin will go active low. All bits in this register must be cleared for the nSMBINT pin to be inactive high.

15.5 Operation of SMBus Interrupt

The operation of the GPIO pins, GPIO data register bits, change status register bits and nSMBINT pin is summarized below.

- A change in the state of a GPIO pin is latched. A change in the state of the GPIO pin will never be missed, even during a read of the data register.
- If a GPIO pin changes more than once in between reads of the data register, the interrupt remains active but the data bit will transition (as in case 2 of Figure 15.2 below).
- If not masked, the change status register bit will be set and the interrupt pin will go active.
- The change status register bit remains set and the interrupt stays active until the associated data register is read.
- The change status register bit and the interrupt is cleared in the start of the read of the associated data register. Note: The nSMBINT pin is cleared when there are no bits set in the GPIO Change Status Register.
- Clearing the mask bit to ‘0’ will cause not an interrupt.
- Writes to the GPIO data register while the GPIO pin is in output mode will not set the status change bit and will not cause the interrupt to go active.
- Writes to the GPIO data register while the GPIO pin is in input mode will not set the status change bit and will not cause the interrupt to go active. The data that is written will be stored in the GPIO output buffer, and when the GPIO is switched from input to output, what is in the output buffer is reflected on the pin.
- Glitch filtering is implemented as follows: Min 15ns, Max 100ns (40ns typical)

Figure 15.2 shows two cases of GPIO transitions and the generation of the SMBus interrupt .

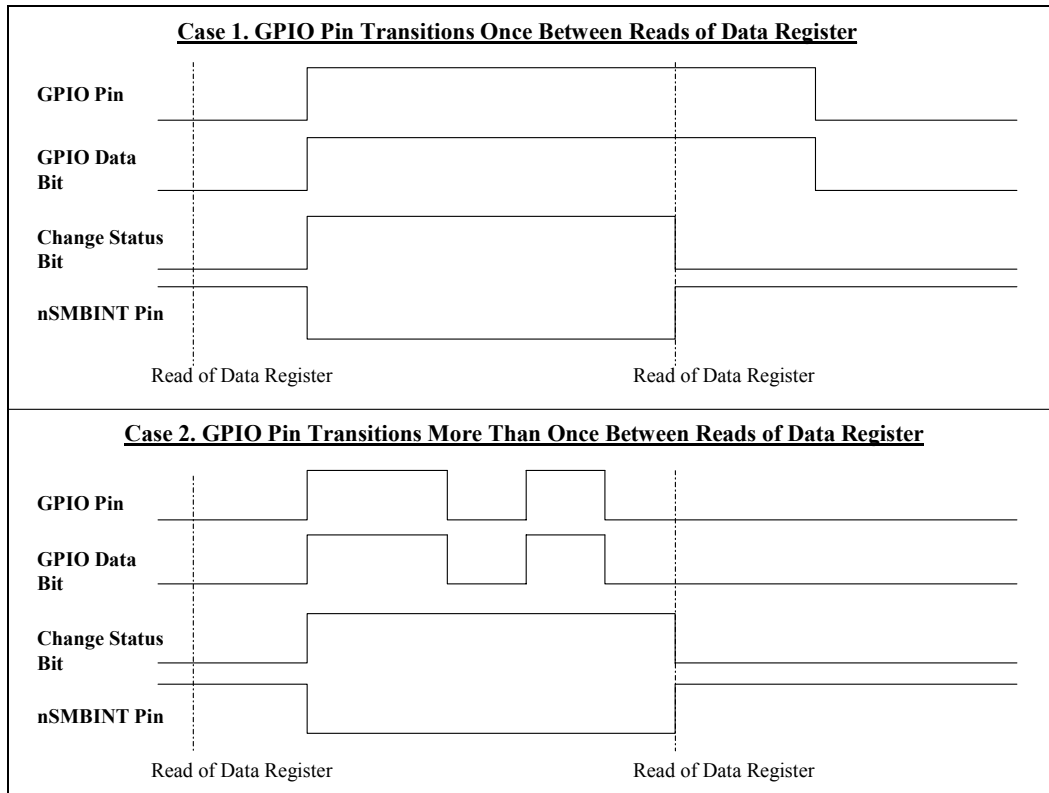
Figure 15.2 - GPIO Transition Cases

See Table 15.5 for a summary of GPIO Event States.

Table 15.5 – SMBus GPIO Events State Table in LPC47N237

State	GPIO Direction 0 = IN 1 = OUT	GPx Pin	GPIO Data Register, GPx Bit	GPIO Mask Register 0 = UnMask 1 = Mask	GPIO Change Status Register 0 = No Change 1 = Change	nSMBINT Pin	Read of GPIO Data Register
S0	0	0	0	0	0	1	No
S1	0	0→1	0→1	0	0→1	1→0	No
S2	0	1	1	0	1→0	0→1	Read
S3	0	1→0	1→0	0	0→1	1→0	No
S4	0	0→1	0→1	0	1	0	No
S5	0	1	1	0	1→0	0→1	Read
S6	0	1	1	0→1	0	1	No
S7	0	1→0	1→0	1	0	1	No
S8	0	0	0	1→0	0	1	No
S9	1	X	X	X	0	1	No

State description:

S0: GPIO pin low, no transition.

S1: GPIO pin transitions from low to high. GPIO data bit changes state to '1'. Sets GPIO Change Status bit, asserts interrupt.

S2: Read of data register clears GPIO Change Status bit, deasserts interrupt. Note: The nSMBINT pin is cleared when there are no bits set in the GPIO Change Status Register.

S3: GPIO pin transitions from high to low. GPIO data bit changes state to '0'. Sets GPIO Change Status bit, asserts interrupt.

S4: GPIO pin transitions from low to high. GPIO data bit changes state, nSMBINT remains active.

S5: Read of data register clears GPIO Change Status bit, deasserts interrupt. Note: The nSMBINT pin is cleared when there are no bits set in the GPIO Change Status Register.

S6: Mask bit is set. No effect on change status bit or interrupt.

S7: GPIO pin transitions from high to low while GPIO is masked. GPIO data bit changes state to '0'. No effect on change status bit or interrupt.

S8: Mask bit is cleared. No effect on change status bit or interrupt.

S9: GPIO in output mode. Change in GPx pin does not effect GPIO data bit for input. Change status bit will not be set and interrupt will not go active regardless of mask bit.

Figure 15.3 shows a representation of the nSMBINT assertion logic. It is not intended to imply a specific logic design.

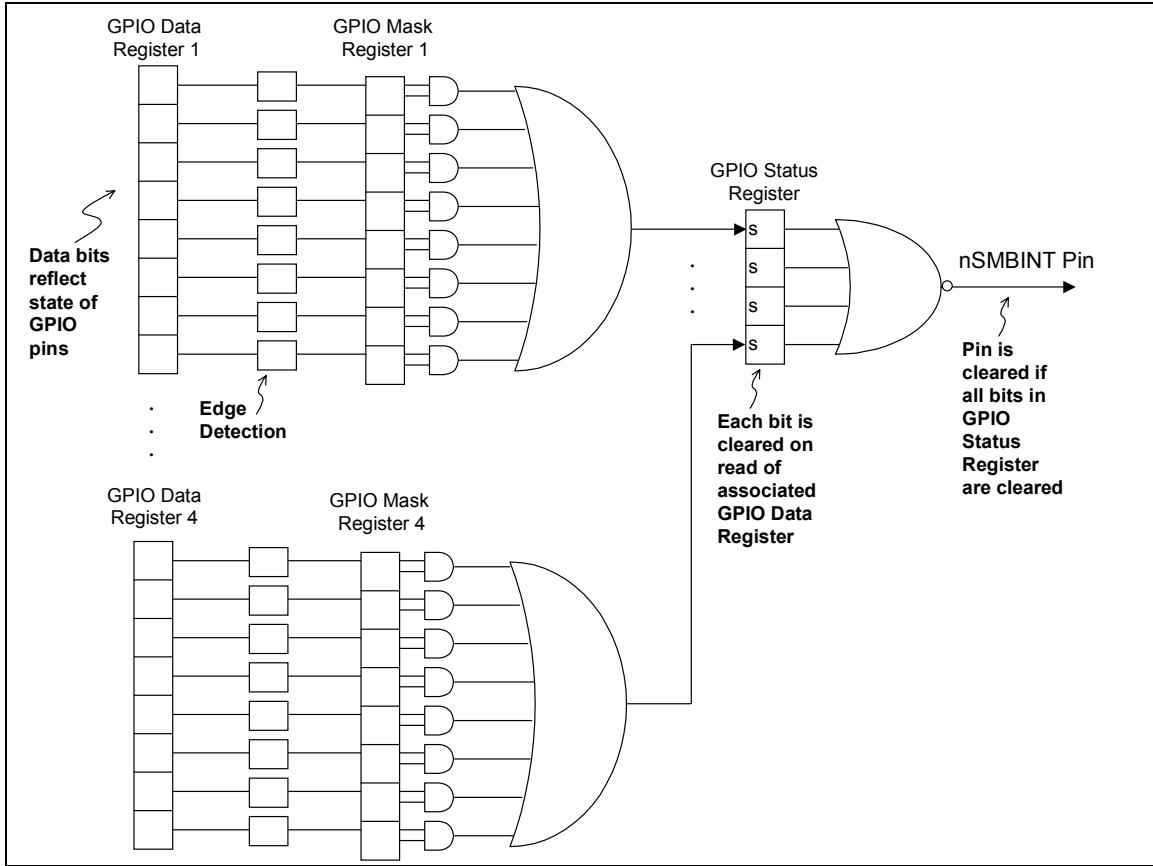

Figure 15.3 – Sample Representation of nSMBINT Assertion Logic

Chapter 16 Runtime Registers

16.1 Runtime Registers Block Summary

The runtime registers are located at the address programmed in the Runtime Register Block Base Address configuration registers located in CR2F and CR30. The part performs 16-bit address qualification on the Runtime Register Base Address (bits[11:0] are decoded and bits[15:12] must be zero). The runtime register block may be located within the range 0x0100-0x0FFC on 4-byte boundaries. Decodes are disabled if the Runtime Register Base Address is located below 0x100. These registers are powered by VTR.

Table 16.1 - Runtime Register Block Summary

REGISTER OFFSET (hex)	TYPE	HARD RESET	VCC POR	VTR POR	REGISTER
00	R/W	-	-	0x00	PME_STS
01	R/W	-	-	0x00	PME_EN
02	R/W	-	-	0x00	LGP_DATA
03	R	-	-	-	Reserved – read only, read returns 0.

Notes:

- Hard Reset: nPCI_RESET pin asserted.
- Reserved bits return 0 on read.

16.2 Runtime Registers Block Description

Table 16.2 – Runtime Registers Block Description

NAME/DEFAULT	REGISTER OFFSET (TYPE)	DESCRIPTION
PME_STS Default = 0x00 on VTR POR	0x00 (R/W)	Bit[0] RI_PME_Status = 0 (default) = 1 Set when nRI1 transitions from high-to-low. If the RI_PME_EN bit is set, nIO_PME pin will be active. Bit[7:1] Reserved PME_Status is not affected by Vcc POR, SOFT RESET or HARD RESET. Writing a “1” to PME_Status will clear it and will stop asserting nIO_PME, if enabled. Writing a “0” to PME_Status has no effect.
PME_EN Default = 0x00 on VTR POR	0x01 (R/W)	Bit[0] RI_PME_EN = 0 nRI wake event disabled = 1 nRI wake event enabled Bit[7:1] Reserved PME_En is not affected by Vcc POR, SOFT RESET or HARD RESET

NAME/DEFAULT	REGISTER OFFSET (TYPE)	DESCRIPTION
LGP_DATA Default = 0x00 on VTR POR	0x02 (R/W)	General Purpose I/O Data Register Bit[3:0] Reserved Bit[4] LGP44 Bit[5] LGP45 Bit[6] LGP46 Bit[7] LGP47
N/A	0x03 (R)	Reserved, read only – read returns 0.

Chapter 17 Configuration

The configuration of the LPC47N237 is programmed through hardware selectable Configuration Access Ports that appear when the chip is placed into the configuration state. The LPC47N237 logical device blocks, if enabled, will operate normally in the configuration state.

17.1 Configuration Access Ports

The Configuration Access Ports are the CONFIG PORT, the INDEX PORT, and the DATA PORT (Table 17.1). The base address of these registers is controlled by the LGP47 (SYSOPT) pin and by the Configuration Port Base Address registers CR12 and CR13. To determine the configuration base address at power-up, the state of the LGP47 (SYSOPT) pin is latched by the falling edge of a hardware reset. If the latched state is a 0, the base address of the Configuration Access Ports is located at address 0x02E; if the latched state is a 1, the base address is located at address 0x04E. The base address is relocatable via CR12 and CR13.

Table 17.1 – Configuration Access Ports

PORT NAME	SYSOPT = 0	SYSOPT = 1	TYPE
CONFIG PORT	0x02E	0x04E	WRITE
INDEX PORT	0x02E	0x04E	READ/WRITE (Note 17.1, Note 17.2)
DATA PORT	INDEX PORT + 1		READ/WRITE (Note 17.1)

Note 17.1 The INDEX and DATA ports are active only when the LPC47N237 is in the configuration state.

Note 17.2 The INDEX PORT is only readable in the configuration state.

17.2 Configuration State

The configuration registers are used to select programmable chip options. The LPC47N237 operates in two possible states: the run state and the configuration state. After power up by default the chip is in the run state. To program the configuration registers, the configuration state must be explicitly enabled. Programming the configuration registers typically follows this sequence:

1. Enter the Configuration State,
2. Program the Configuration Register(s),
3. Exit the Configuration State.

17.2.1 Entering the Configuration State

To enter the configuration state write the Configuration Access Key to the CONFIG PORT. The Configuration Access Key is one byte of 55H data. The LPC47N237 will automatically activate the Configuration Access Ports following this procedure.

17.2.2 Configuration Register Programming

The LPC47N237 contains configuration registers CR00-CR39. After the LPC47N237 enters the configuration state, configuration registers can be programmed by first writing the register index number (00 - 39H) to the Configuration Select Register (CSR) through the INDEX PORT and then writing or reading the configuration register contents through the DATA PORT. Configuration register access remains enabled until the configuration state is explicitly exited.

17.2.3 Exiting the Configuration State

To exit the configuration state, write one byte of AAH data to the CONFIG PORT. The LPC47N237 will automatically deactivate the Configuration Access Ports following this procedure, at which point configuration register access cannot occur until the configuration state is explicitly re-enabled.

17.2.4 Programming Example

The following is a configuration register programming example written in Intel 8086 assembly language.

```
-----  
; ENTER CONFIGURATION STATE |  
-----  
MOV  DX,02EH      ;SYSOPT = 0  
MOV  AX,055H  
OUT  DX,AL  
-----  
; CONFIGURE REGISTER CR0-CRx |  
-----  
MOV  DX,02EH  
MOV  AL,00H  
OUT  DX,AL      ;Point to CR0  
MOV  DX,02FH  
MOV  AL,3FH  
OUT  DX,AL      ;Update CR0  
;  
MOV  DX,02EH  
MOV  AL,01H  
OUT  DX,AL      ;Point to CR1  
MOV  DX,02FH  
MOV  AL,9FH  
OUT  DX,AL      ;Update CR1  
;  
; Repeat for all CRx registers  
;  
-----  
; EXIT CONFIGURATION STATE |  
-----  
MOV  DX,02EH  
MOV  AX,AAH  
OUT  DX,AL
```

17.2.5 Configuration Select Register (CSR)

The Configuration Select Register can only be accessed when the LPC47N237 is in the configuration state. The CSR is located at the INDEX PORT address and must be initialized with configuration register index before the register can be accessed using the DATA PORT.

17.3 Configuration Registers Summary

The configuration registers are set to their default values at power up and are RESET as indicated in Table 17.2 and the register descriptions that follow.

Table 17.2 – Configuration Registers Summary

REGISTER INDEX	TYPE	HARD RESET (NOTE 17.3)	VCC POR	VTR POR	REGISTER
CR00	R/W	-	0x20	-	Valid Config Cycle
CR01	R/W	bit[7]=1	0x9C	-	PP Power/Mode/CR Lock
CR02	R/W	-	0x08	-	UART Power
CR03	R	-	-	-	Reserved – read only, read returns 0.
CR04	R/W	-	0x00	-	PP and UART Miscellaneous
CR05	R	-	-	-	Reserved – read only, read returns 0.
CR06	R	-	-	-	Reserved – read only, read returns 0.
CR07	R/W	-	0x00	-	Auto Power Management
CR08	R/W	-	-	-	Reserved – read only, read returns 0.
CR09	R/W	-	0x00	-	Test 4
CR0A	R/W	-	0x00	-	ECP FIFO Threshold
CR0B	R	-	-	-	Reserved – read only, read returns 0.
CR0C	R/W	0x00	0x00	-	UART Mode
CR0D	R	-	0x13	-	Device ID
CR0E	R	-	0x00	-	Revision ID
CR0F	R/W	-	0x00	-	Test 1
CR10	R/W	-	0x00	-	Test 2
CR11	R/W	-	0x00	-	Test 3
CR12	R/W	SYSOPT=0:0x2E SYSOPT=1:0x4E		-	Configuration Base Address 0
CR13	R/W	SYSOPT=0:0x00 SYSOPT=1:0x00		-	Configuration Base Address 1
CR14	R	-	-	-	Reserved – read only, read returns 0.
CR15	R	-	-	-	UART FCR Shadow
CR16	R	-	-	-	Reserved – read only, read returns 0.
CR17	R	-	-	-	Reserved – read only, read returns 0.
CR18	R	-	-	-	Reserved – read only, read returns 0.
CR19	R	-	-	-	Reserved – read only, read returns 0.
CR1A	R	-	-	-	Reserved – read only, read returns 0.
CR1B	R	-	-	-	Reserved – read only, read returns 0.

REGISTER INDEX	TYPE	HARD RESET (NOTE 17.3)	VCC POR	VTR POR	REGISTER
CR1C	R	-	-	-	Reserved – read only, read returns 0.
CR1D	R	-	-	-	Reserved – read only, read returns 0.
CR1E	R	-	-	-	Reserved – read only, read returns 0.
CR1F	R	-	-	-	Reserved – read only, read returns 0.
CR20	R	-	-	-	Reserved – read only, read returns 0.
CR21	R/W	-	0x00	-	EPP Timeout Select
CR22	R/W	0x00	0x00	-	ECP Software Select
CR23	R/W	-	0x00	-	Parallel Port Base Address
CR24	R/W	-	0x00	-	UART Base Address
CR25	R	-	-	-	Reserved – read only, read returns 0.
CR26	R/W	-	0x00	-	PP DMA Select
CR27	R/W	-	0x00	-	PP IRQ Select
CR28	R/W	-	0x00	-	UART IRQ Select
CR29	R/W	-	0x80	-	SIRQ_CLKRUN_En
CR2A	R	-	-	-	Reserved – read only, read returns 0.
CR2B	R	-	-	-	Reserved – read only, read returns 0.
CR2C	R	-	-	-	Reserved – read only, read returns 0.
CR2D	R	-	-	-	Reserved – read only, read returns 0.
CR2E	R	-	-	-	Reserved – read only, read returns 0.
CR2F	R/W	-	0x00	-	Runtime Register Block Address 2
CR30	R/W	-	0x00	-	Runtime Register Block Address 1
CR31	R	-	-	-	Reserved – read only, read returns 0.
CR32	R	-	-	-	Reserved – read only, read returns 0.
CR33	R	-	-	-	Reserved – read only, read returns 0.
CR34	R	-	-	-	Reserved – read only, read returns 0.
CR35	R	-	-	-	Reserved – read only, read returns 0.
CR36	R	-	-	-	Reserved – read only, read returns 0.
CR37	R/W	-	-	0x00	LPC GPIO Direction Register
CR38	R/W	-	-	0x00	LPC GPIO Polarity Register

REGISTER INDEX	TYPE	HARD RESET (NOTE 17.3)	VCC POR	VTR POR	REGISTER
CR39	R/W	-	-	0x80	nIO_PME Output Type and Polarity
CR3A – CR3F	R	-	-	-	Reserved – read only, read returns 0.

Note 17.3 Hard Reset: nPCI_RESET pin asserted.

17.4 Configuration Registers Description

17.4.1 CR00

CR00 can only be accessed in the configuration state and after the CSR has been initialized to 00H.

Table 17.3 – CR00

Valid Configuration Cycle		
Type: R/W		Default: 0x20 on VCC POR
BIT NO.	BIT NAME	DESCRIPTION
0-2	Reserved	Read Only. A read returns 0
3-6	Reserved	Read only. A read returns bit 5 as a 1 and bits 3, 4 and 6 as a 0.
7	Valid	A high level on this software controlled bit can be used to indicate that a valid configuration cycle has occurred. The control software must take care to set this bit at the appropriate times. Set to zero after power up. This bit has no effect on any other hardware in the chip.

17.4.2 CR01

CR01 can only be accessed in the configuration state and after the CSR has been initialized to 01H.

Table 17.4 – CR01

PP Power/Mode/CR Lock		
Type: R/W		Default: 0x9C on VCC POR; Bit[7] = 1 on HARD RESET
BIT NO.	BIT NAME	DESCRIPTION
0,1	Reserved	Read Only. A read returns "0".
2	Parallel Port Power (Note 17.4)	A high level on this bit, supplies power to the Parallel Port (Default). A low level on this bit puts the Parallel Port in low power mode.
3	Parallel Port Mode	Parallel Port Mode. A high level on this bit, sets the Parallel Port for Printer Mode (Default). A low level on this bit enables the Extended Parallel port modes. Refer to Bits 0 and 1 of CR4
4	Reserved	Read Only. A read returns "1".
5,6	Reserved	Read Only. A read returns "0".
7	Lock CRx	A high level on this bit enables the reading and writing of CR00 – CR39 (Default). A low level on this bit disables the reading and writing of CR00 – CR39. Note: once the Lock CRx bit is set to "0", this bit can only be set to "1" by a hard reset or power-up reset.

Note 17.4 Power Down bits disable the respective logical device and associated pins, however the power down bit does not disable the selected address range for the logical device. To disable the host address registers the logical device's base address must be set below 100h. Devices that are powered down but still reside at a valid I/O base address will participate in Plug-and-Play range checking.

17.4.3 CR02

CR02 can only be accessed in the configuration state and after the CSR has been initialized to 02H.

Table 17.5 – CR02

UART Power		
Type: R/W		Default: 0x08 on VCC POR; Bit[7] = 0 on HARD RESET
BIT NO.	BIT NAME	DESCRIPTION
0-2	Reserved	Read Only. A read returns "0".
3	UART Power Down	A high level on this bit, allows normal operation of the Primary Serial Port (Default). A low level on this bit places the Primary Serial Port into Power Down Mode.
4-7	Reserved	Read Only. A read returns "0".

Note: Power Down bits disable the respective logical device and associated pins, however the power down bit does not disable the selected address range for the logical device. To disable the host address registers the logical device's base address must be set below 100h. Devices that are powered down but still reside at a valid I/O base address will participate in Plug-and-Play range checking.

17.4.4 CR03

This register is reserved, read only, and returns 0 when read.

17.4.5 CR04

CR04 can only be accessed in the configuration state and after the CSR has been initialized to 04H.

Table 17.6 – CR04

PP and UART Miscellaneous				
Type: R/W			Default: 0x00 on VCC POR	
BIT NO.	BIT NAME	DESCRIPTION		
1,0	Parallel Port Extended Modes	Bit 1	Bit 0	If CR1 bit 3 is a low level then:
		0	0	Standard and Bi-directional Modes (SPP) (default)
		0	1	EPP Mode and SPP
		1	0	ECP Mode (Note 17.6)
		1	1	ECP Mode & EPP Mode (Note 17.5, Note 17.6)
2,3	Reserved	Reserved - Read as 0.		
4	MIDI 1 (Note 17.7)	Serial Clock Select Port: A low level on this bit disables MIDI support (default). A high level on this bit enables MIDI support.		
5	Reserved	Reserved - Read as 0.		
6	EPP Type	0 = EPP 1.9 (default) 1 = EPP 1.7		
7	Reserved	Reserved - Read as 0.		

Note 17.5 In this mode, EPP can be selected through the ecr register of ECP as mode 100.

Note 17.6 SPP can be selected through the ecr register of ECP as mode 000.

Note 17.7 MIDI Support: The Musical Instrumental Digital Interface (MIDI) operates at 31.25Kbaud (+/-1%).

17.4.6 CR05 – CR06

These registers are reserved, read only, and return 0 when read.

17.4.7 CR07

CR07 can only be accessed in the configuration state and after the CSR has been initialized to 07H. CR07 controls auto power management.

Table 17.7 – CR07

Auto Power Management		
Type: R/W		Default: 0x00 on VCC POR; Bits[7:4] = 0000 on HARD RESET
BIT NO.	BIT NAME	DESCRIPTION
0-3	Reserved	Read Only. A read returns 0.
4	Parallel Port Enable	This bit controls the AUTOPOWER DOWN feature of the Parallel Port. The function is: 0 = Auto powerdown disabled (default) 1 = Auto powerdown enabled This bit is reset to the default state by POR or a hardware reset.
5	Reserved	Read Only. A read returns 0.
6	UART Enable	This bit controls the AUTOPOWER DOWN feature of the UART. The function is: 0 = Auto powerdown disabled (default) 1 = Auto powerdown enabled This bit is reset to the default state by POR or a hardware reset.
7	Reserved	Read Only. A read returns 0.

17.4.8 CR08

This register is reserved, read only, and returns 0 when read.

17.4.9 CR09

CR09 can only be accessed in the configuration state and after the CSR has been initialized to 09H. CR09 is a test control register and all bits must be treated as Reserved.

Note: All test modes are reserved for SMSC use. Activating test mode registers may produce undesired results.

Table 17.8 – CR09

Test 4		
Type: R/W		Default: 0x00 on VCC POR
BIT NO.	BIT NAME	DESCRIPTION
0	Test 24	RESERVED FOR SMSC USE
1	Test 25	
2	Test 26	
3	Test 27	
4	Test 28	
5	Test 29	
6	Test 30	
7	Test 31	

17.4.10 CR0A

CR0A can only be accessed in the configuration state and after the CSR has been initialized to 0AH. CR0A defines the FIFO threshold for the ECP mode parallel port.

Table 17.9 – CR0A

ECP FIFO Threshold/IR MUX		
Type: R/W		Default: 0x00 on VCC POR; Bits[7:6] = 00 on HARD RESET
BIT NO.	BIT NAME	DESCRIPTION
0	THR0	ECP FIFO Threshold 0.
1	THR1	ECP FIFO Threshold 1.
2	THR2	ECP FIFO Threshold 2.
3	THR3	ECP FIFO Threshold 3.
4-7	Reserved	Read Only. A read returns 0.

17.4.11 CR0B

This register is reserved, read only, and returns 0 when read.

17.4.12 CR0C

CR0C can only be accessed in the configuration state and after the CSR has been initialized to 0CH. CR0C controls the operating mode of the UART. This register is reset to the default state by a POR or a hardware reset.

Table 17.10 – CR0C

UART Mode		
Type: R/W		Default: 0x00 on VCC POR and HARD RESET
BIT NO.	BIT NAME	DESCRIPTION
0-5	Reserved	Read Only. A read returns 0.
6	UART Speed	This bit enables the high speed mode of UART. 1 = High speed enabled 0 = Standard (default)
7	Reserved	Read Only. A read returns 0.

17.4.13 CR0D

CR0D can only be accessed in the configuration state and after the CSR has been initialized to 0DH. This register is read only. CR0D contains the LPC47N237 Device ID. This register is hardwired to 13H.

17.4.14 CR0E

CR0E can only be accessed in the configuration state and after the CSR has been initialized to 0EH. This register is read only. CR0E contains the current LPC47N237 Chip Revision Level starting at 00H.

17.4.15 CR0F

CR0F can only be accessed in the configuration state and after the CSR has been initialized to 0FH. CR0F is a test control register and all bits must be treated as Reserved.

Note: All test modes are reserved for SMSC use. Activating test mode registers may produce undesired results.

Table 17.11 – CR0F

Test 1		
Type: R/W		Default: 0x00 on VCC POR
BIT NO.	BIT NAME	DESCRIPTION
0	Test 0	RESERVED FOR SMSC USE
1	Test 1	
2	Test 2	
3	Test 3	
4	Test 4	
5	Test 5	
6	Test 6	
7	Test 7	

17.4.16 CR10

CR10 can only be accessed in the configuration state and after the CSR has been initialized to 10H. CR10 is a test control register and all bits must be treated as Reserved.

Note: All test modes are reserved for SMSC use. Activating test mode registers may produce undesired results.

Table 17.12 – CR10

Test 2		
Type: R/W		Default: 0x00 on VCC POR
BIT NO.	BIT NAME	DESCRIPTION
0	Test 8	RESERVED FOR SMSC USE
1	Test 9	
2	Test 10	
3	Test 11	
4	Test 12	
5	Test 13	
6	Test 14	
7	Test 15	

17.4.17 CR11

CR11 can only be accessed in the configuration state and after the CSR has been initialized to 11H. CR11 is a test control register and all bits must be treated as Reserved.

Note: All test modes are reserved for SMSC use. Activating test mode registers may produce undesired results.

Table 17.13 – CR11

Test 3		
Type: R/W		Default: 0x00 on VCC POR
BIT NO.	BIT NAME	DESCRIPTION
0	Test 16	RESERVED FOR SMSC USE
1	Test 17	
2	Test 18	
3	Test 19	
4	Test 20	
5	Test 21	
6	Test 22	
7	Test 23	

17.4.18 CR12 - CR13

CR12 and CR13 are the LPC47N237 Configuration Ports base address registers. These registers are used to relocate the Configuration Ports base address beyond the power-up defaults determined by the SYSOPT pin programming.

CR12 contains the Configuration Ports base address bits A[7:0]. CR13 contains the Configuration Ports base address bits A[10:8]. The address bits A[15:11] must be '00000' to access the configuration port.

The Configuration Ports base address is relocatable on even-byte boundaries; i.e., A0 = '0'.

At power-up the Configuration Ports base address is determined by the SYSOPT pin programming. To relocate the Configuration Ports base address after power-up, first write the lower address bits of the new base address to CR12 and then write the upper address bits to CR13.

Note: Writing CR13 changes the Configuration Ports base address.

Table 17.14 – CR12

Configuration Ports Base Address Byte 0 (Note)		
Type: R/W		Default: 0x2E (SYSOPT=0) 0x4E (SYSOPT=1) on VCC POR and HARD RESET
BIT NO.	BIT NAME	DESCRIPTION
0	Reserved	Read Only. A read returns 0.
1	A1	Configuration Ports Base Address Byte 0 for decoder.
2	A2	
3	A3	
4	A4	
5	A5	
6	A6	
7	A7	

Note: The Configuration Ports Base Address is relocatable on even-byte boundaries; i.e., A0 = "0".

Table 17.15 – CR13

Configuration Ports Base Address Byte 1 (Note)		
Type: R/W		Default: 0x00 (SYSOPT=0) 0x00 (SYSOPT=1) on VCC POR and HARD RESET
BIT NO.	BIT NAME	DESCRIPTION
0	A8	Configuration Ports Base Address Byte 1 for decoder.
1	A9	
2	A10	
3-7	Reserved	Read Only. A read returns 0.

Note: Writing CR13 changes the Configuration Ports base address.

17.4.19 CR14

This register is reserved, read only, and returns 0 when read.

17.4.20 CR15

CR15 can only be accessed in the configuration state and after the CSR has been initialized to 15H. CR15 shadows the bits in the write-only UART run-time FCR register.

Table 17.16 - CR15

UART FCR Shadow Register			
Type: R/W		Default: N/A	
BIT NO.	BIT NAME	DESCRIPTION	
0	FIFO Enable	Setting this bit to a logic "1" enables both the XMIT and RCVR FIFOs	
1	RCVR FIFO Reset	Setting this bit to a logic "1" clears all bytes in the RCVR FIFO and resets its counter logic to 0. This bit is self clearing.	
2	XMIT FIFO Reset	Setting this bit to a logic "1" clears all bytes in the XMIT FIFO and resets its counter logic to 0. This bit is self-clearing.	
3	DMA Mode Select	Writing to this bit has no effect on the operation of the UART.	
4,5	Reserved	Read Only. A read returns 0.	
6,7	RCVR Trigger	These bits are used to set the trigger level for the RCVR FIFO interrupt.	
		BIT7	BIT6
		0	0
		0	1
		1	0
		1	1
		RCVR FIFO TRIGGER LEVEL (BYTES)	
		1	
		4	
		8	
		14	

17.4.21 CR16 – CR20

These registers are reserved, read only, and return 0 when read.

17.4.22 CR21

CR21 can only be accessed in the configuration state and after the CSR has been initialized to 21H.

Table 17.17 – CR21

EPP Timeout Select		
Type: R/W		Default: 0x00 on VCC POR
BIT NO.	BIT NAME	DESCRIPTION
0,1	Reserved	Read Only. A read returns 0.
2	TIMEOUT_SELECT	This bit selects the means of clearing the TIMEOUT bit in the EPP Status register. If the TIMEOUT_SELECT bit is cleared ('0'), the TIMEOUT bit is cleared on the trailing edge of the read of the EPP Status Register (default). If the TIMEOUT_SELECT bit is set ('1'), the TIMEOUT bit is cleared on a write of '1' to the TIMEOUT bit.
3-7	Reserved	Read Only. A read returns 0.

17.4.23 CR22

The ECP Software Select register CR22 contains the ECP IRQ Select bits and the ECP DMA Select bits. CR22 is part of the ECP DMA/IRQ Software Indicators described in the ECP cnfgB register. CR22 is read/write.

Note: All of the ECP DMA/IRQ Software Indicators, including CR22, are software-only. Writing these bits does not affect the ECP hardware DMA or IRQ channels that are configured in CR26 and CR27.

Table 17.18 - CR22

ECP Software Select Register		
Type: R/W		Default: 0x00 on VCC POR and HARD RESET
BIT NO.	BIT NAME	DESCRIPTION
2:0	ECP DMA Select	ECP DMA software Indicator
5:3	ECP IRQ Select	ECP IRQ Software Indicator
6,7	Reserved	Read Only. A read returns 0.

17.4.24 CR23

CR23 can only be accessed in the configuration state and after the CSR has been initialized to 23H. CR23 is used to select the base address of the parallel port. If EPP is not enabled, the parallel port can be set to 192 locations on 4-byte boundaries from 100H - 3FCH; if EPP is enabled, the parallel port can be set to 96 locations on 8-byte boundaries from 100H - 3F8H. To disable the parallel port, set ADR9 and ADR8 to zero.

Parallel Port Address Decoding: address bits A[15:10] must be '000000' to access the Parallel Port when in Compatible, Bi-directional, or EPP modes. A10 is active when in ECP mode.

Table 17.19 - CR23

Parallel Port Base Address		
Type: R/W		Default: 0x00 on VCC POR
BIT NO.	BIT NAME	DESCRIPTION
0	ADR2	Parallel Port Base Address bits for decoder.
1	ADR3	
2	ADR4	
3	ADR5	
4	ADR6	
5	ADR7	
6	ADR8	
7	ADR9	

Table 17.20 - Parallel Port Addressing Options

EPP ENABLED	ADDRESSING (LOW BITS) DECODE
No	A[1:0] = XXb
Yes	A[2:0] = XXXb

17.4.25 CR24

CR24 can only be accessed in the configuration state and after the CSR has been initialized to 24H. CR24 is used to select the base address of Serial Port (UART). The serial port can be set to 96 locations on 8-byte boundaries from 100H - 3F8H. To disable Serial Port, set ADR9 and ADR8 to zero. Set CR24.0 to 0 when writing the UART Base Address.

Serial Port Address Decoding: address bits A[15:10] must be '000000' to access UART registers. A[2:0] are decoded as XXXb.

Table 17.21 - CR24

UART Base Address Register		
Type: R/W		Default: 0x00 on VCC POR
BIT NO.	BIT NAME	DESCRIPTION
0	Reserved	Read Only. A read returns 0.
1	ADR3	Serial Port Base Address bits for decoder.
2	ADR4	
3	ADR5	
4	ADR6	
5	ADR7	
6	ADR8	
7	ADR9	

17.4.26 CR25

This register is reserved, read only, and returns 0 when read.

17.4.27 CR26

CR26 can only be accessed in the configuration state and after the CSR has been initialized to 26H. CR26 is used to select the DMA for the Parallel Port (bits 0 - 3). Any unselected DMA Request output (DRQ) is in tristate.

Table 17.22 - CR26

PP DMA Selection Register		
Type: R/W		Default: 0x00 on VCC POR
BIT NO.	BIT NAME	DESCRIPTION
3:0	PP DMA Select	These bits are used to select DMA for Parallel Port.
7:4	Reserved	Read Only. A read returns 0.

Table 17.23 - DMA Selection

BITS[3:0] OR BITS[7:4]	DMA SELECTED
0000	RESERVED
0001	DMA1
0010	DMA2
0011	DMA3
0100	RESERVED
....
....
1110	RESERVED
1111	NONE

17.4.28 CR27

CR27 can only be accessed in the configuration state and after the CSR has been initialized to 27H. CR27 is used to select the IRQ for the Parallel Port (bits 3 - 0). Any unselected IRQ output (registers CR27 - CR29) is in tri-state.

Table 17.24 - CR27

PP IRQ Selection Register		
Type: R/W		Default: 0x00 on VCC POR
BIT NO.	BIT NAME	DESCRIPTION
3:0	PP IRQ Select	These bits are used to select IRQ for Parallel Port.
7:4	Reserved	Read Only. A read returns 0.

Table 17.25 – IRQ Encoding

BITS[3:0] OR BITS[7:4]	IRQ SELECTED
0000	NONE
0001	IRQ_1
0010	IRQ_2
0011	IRQ_3
0100	IRQ_4
0101	IRQ_5
0110	IRQ_6
0111	IRQ_7
1000	IRQ_8
1001	IRQ_9
1010	IRQ_10
1011	IRQ_11
1100	IRQ_12
1101	IRQ_13
1110	IRQ_14
1111	IRQ_15

17.4.29 CR28

CR28 can only be accessed in the configuration state and after the CSR has been initialized to 28H. CR28 is used to select the IRQ for Serial Port (bits 7 - 4). Refer to the IRQ encoding for CR27 (Table 17.25). Any unselected IRQ output (registers CR27 - CR28) is in tristate.

Table 17.26 – CR28

UART Interrupt Selection		
Type: R/W		Default: 0x00 on VCC POR
BIT NO.	BIT NAME	DESCRIPTION
3:0	Reserved	Read Only. A read returns 0.
7:4	UART IRQ Select	These bits are used to select IRQ for Serial Port. See IRQ encoding for CR27 (Table 17.25).

Table 17.27 – UART Interrupt Operation

UART		IRQ PIN
UART OUT2 bit	UART IRQ Output State	UART Pin State
0	Z	Z
1	asserted	1
1	de-asserted	0
0	Z	Z
0	Z	Z
1	asserted	1
1	asserted	1
1	de-asserted	0
1	de-asserted	0

17.4.30 CR29

CR29 can only be accessed in the configuration state and after the CSR has been initialized to 29H.

Table 17.28 – CR29

SIRQ_CLKRUN_En		
Type: R/W		Default: 0x80 on VCC POR
BIT NO.	BIT NAME	DESCRIPTION
0-6	Reserved	Read Only. A read returns 0.
7	SIRQ_CLKRUN_EN	Serial IRQ and CLKRUN enable bit. 0 = Disable 1 = Enable (default)

17.4.31 CR2A – CR2E

These registers are reserved, read only, and return 0 when read.

17.4.32 CR2F – CR30

CR2F and CR30 can only be accessed in the configuration state and after the CSR has been initialized to 2FH and 30H. The CR2F and CR30 are used to set the Runtime Register Block base address ADR[11:2]. The Runtime Register Block base address can be set to 960 locations on 4-byte boundaries from 100H – FFCH. To disable Runtime Registers Block, set ADR11 – ADR8 to zero.

SCE Address Decoding: address bits A[15:12] must be '0000' to access Runtime Register Block registers. A[1:0] are decoded as XXb.

Table 17.29 – CR2F

Runtime Registers Block Base Address 2		
Type: R/W		Default: 0x00 on VCC POR
BIT NO.	BIT NAME	DESCRIPTION
0-5	Reserved	Read only, read returns 0.
6	ADR2	The bits in this register along with CR30 are used to program the location of the Runtime Register Block Base Address.
7	ADR3	

Table 17.30 – CR30

Runtime Registers Block Base Address 1		
Type: R/W		Default: 0x00 on VCC POR
BIT NO.	BIT NAME	DESCRIPTION
0	ADR4	The bits in this register along with CR2F are used to program the location of the Runtime Register Block Base Address.
1	ADR5	
2	ADR6	
3	ADR7	
4	ADR8	
5	ADR9	
6	ADR10	
7	ADR11	

17.4.33 CR31 – CR36

These registers are reserved, read only, and return 0 when read.

17.4.34 CR37

CR37 can only be accessed in the configuration state and after the CSR has been initialized to 37H. CR37 is the LPC GPIO Direction Register and is used to select the direction of LGP44-LGP47 pins.

Table 17.31 – CR37

LPC GPIO Direction Register		
Type: R/W		Default: 0x00 on VTR POR
BIT NO.	BIT NAME	DESCRIPTION
0	Reserved	The bits in this register are used to select the direction of the LGP44-LGP47 pins. 0=Input 1=Output
1	Reserved	
2	Reserved	
3	Reserved	
4	LGP44	
5	LGP45	
6	LGP46	
7	LGP47	

17.4.35 CR38

CR38 can only be accessed in the configuration state and after the CSR has been initialized to 38H. CR38 is the LPC GPIO Polarity Register and is used to select the polarity of LGP44-LGP47 pins.

Table 17.32 – CR38

LPC GPIO Polarity Register		
Type: R/W		Default: 0x00 on VTR POR
BIT NO.	BIT NAME	DESCRIPTION
0	Reserved	The bits in this register are used to select the polarity of the LGP44-LGP47 pins. 0=Non-Inverted 1=Inverted
1	Reserved	
2	Reserved	
3	Reserved	
4	LGP44	
5	LGP45	
6	LGP46	
7	LGP47	

17.4.36 CR39

CR39 can only be accessed in the configuration state and after the CSR has been initialized to 39H. CR39 is used to program nIO_PME pin output type and polarity.

Table 17.33 – CR39

nIO_PME Output Type and Polarity		
Type: R/W		Default: 0x80 on VTR POR
BIT NO.	BIT NAME	DESCRIPTION
5:0	Reserved	Read Only. A read returns 0.
6	nIO_PME Polarity Select	This bit is used to select the polarity of the nIO_PME pin 0=Non-Inverted 1=Inverted Note: configuring this pin function with non-inverted polarity will give an active low output signal. The output type can be either open drain or push-pull.
7	nIO_PME	The bits in this register are used to select the output buffer type of the nIO_PME pin. 0=Push-pull 1=Open Drain

17.5 Logical Device Base I/O Address and Range

Table 17.34 – I/O Base Address Configuration Register Description

LOGICAL DEVICE	REGISTER INDEX	BASE I/O RANGE	FIXED BASE OFFSETS
Parallel Port	0x23	[0x0100:0x03FC] on 4-byte boundaries (EPP Not supported) or [0x0100:0x03F8] on 8-byte boundaries	+0 : Data/ecpAfifo +1 : Status +2 : Control +400h : cfifo/ecpDfifo/tfifo/cnfgA +401h : cnfgB +402h : ecr
		(all modes supported, EPP is only available when the base address is on an 8-byte boundary)	+3 : EPP Address +4 : EPP Data 0 +5 : EPP Data 1 +6 : EPP Data 2 +7 : EPP Data 3
Serial Port	0x24	[0x0100:0x03F8] on 8 byte boundaries	+0 : RB/TB/LSB div +1 : IER/MSB div +2 : IIR/FCR +3 : LCR +4 : MCR +5 : LSR +6 : MSR +7 : SCR
Runtime Register Block	0x2F and 0x30	[0x0100:0x0FFC] on 4-byte boundaries	+00 : PME_STS +01: PME_EN +02: LGP_DATA +03: Reserved

LOGICAL DEVICE	REGISTER INDEX	BASE I/O RANGE	FIXED BASE OFFSETS
Config. Port	0x12, 0x13 (Note 17.8)	[0x0100:0x07FE] On 2-byte boundaries	See Configuration Registers in Table 17.2. They are accessed through the index and DATA ports located at the Configuration Port address and the Configuration Port address +1 respectively.

Note 17.8 The Configuration Port is at either 0x02E or 0x04E (for SYSOPT=0 or SYSOPT=1) at power up and can be relocated via CR12 and CR13.

17.6 Note A. Logical Device IRQ and DMA Operation

IRQ and DMA Enable and Disable: Any time the IRQ or DMA channel for a logical block is disabled by a register bit in that logical block, the IRQ and/or DMA channel is disabled. This is in addition to the IRQ and DMA channel disabled by the Configuration Registers (active bit or address not valid).

Parallel Port:

- I. SPP and EPP modes: Control Port (Base+2) bit D4 (IRQE) set to "0", IRQ is disabled.
- ii. ECP Mode:
 - (1) (DMA) dmaEn from ecr register. See table below.
 - (2) IRQ - See table below.

MODE (FROM ECR REGISTER)		IRQ CONTROLLED BY	DMA CONTROLLED BY
000	PRINTER	IRQE	dmaEn
001	SPP	IRQE	dmaEn
010	FIFO	(on)	dmaEn
011	ECP	(on)	dmaEn
100	EPP	IRQE	dmaEn
101	RES	IRQE	dmaEn
110	TEST	(on)	dmaEn
111	CONFIG	IRQE	dmaEn

Chapter 18 SMBus GPIO Register Map

The SMBus runtime registers are located at the address shown from the SMBus slave address. These registers are powered by VTR. Reserved bits and registers return 0 on read.

18.1 SMBus GPIO Register Summary

Table 18.1 – SMBus GPIO Register Summary

REGISTER ADDRESS (HEX)	TYPE	VTR POR	REGISTER
00	R	0x5C	Company ID
01	R	0x00	Revision Number
02 – 0D	R	-	Reserved – read only, read returns 0.
0E	R/W	0x00	SMBus Isolation
0F	R/W	0x00	GPCHG_STS
10	R/W	0x00	GPDIR1
11	R/W	0x00	GPDIR2
12	R/W	0x00	GPDIR3
13	R/W	0x00	GPDIR4
14	R/W	0x00	GPOT1
15	R/W	0x00	GPOT2
16	R/W	0x00	GPOT3
17	R/W	0x00	GPOT4
18	R/W	0x00	GP1
19	R/W	0x00	GP2
1A	R/W	0x00	GP3
1B	R/W	0x00	GP4
1C	R/W	0x00	GPMSK1
1D	R/W	0x00	GPMSK2
1E	R/W	0x00	GPMSK3
1F	R/W	0x00	GPMSK4

18.2 SMBus GPIO Register Description

Table 18.2 – SMBus GPIO Register Description

NAME/DEFAULT	REGISTER OFFSET (TYPE)	DESCRIPTION
Company ID	0x00 (R)	This register is hardwired to 0x5C for Company ID.
Revision Number	0x01 (R)	This register is hardwired to 0x00 for Revision Number.
N/A	0x02 – 0x0D (R)	Reserved, read only. Read returns 0.

NAME/DEFAULT	REGISTER OFFSET (TYPE)	DESCRIPTION
SMBus Isolation Default = 0x00 on VTR POR	0x0E (R/W)	SMBus Isolation Select. Bits[1:0] control which pair of SMBus pins (SCLK_1/SDAT_1, SCLK_2/SDAT_2) are connected to the SMBus. Bits[1:0]: SMBus Isolation Select 00= both SMBus devices isolated from SMBus (default) 01= SCLK_1/SDAT_1 connected to SMBus 10= SCLK_2/SDAT_2 connected to SMBus 11= both SMBus devices connected to SMBus Bits[7:2] Reserved.
GPCHG_STS Default = 0x00 on VTR POR	0x0F (R/W)	GPIO Change Status Register 0 = No Change since last GP data register read 1 = Changed since last GP data register read Bit[0] GP1 Data Register Bit[1] GP2 Data Register Bit[2] GP3 Data Register Bit[3] GP4 Data Register Bit[7:4] Reserved
GPDIR1 Default = 0x00 on VTR POR	0x10 (R/W)	GPIO Direction Register 1 0 = Input 1 = Output Bit[0] GP10 Bit[1] GP11 Bit[2] GP12 Bit[3] GP13 Bit[4] GP14 Bit[5] GP15 Bit[6] GP16 Bit[7] GP17
GPDIR2 Default = 0x00 on VTR POR	0x11 (R/W)	GPIO Direction Register 2 0 = Input 1 = Output Bit[0] GP20 Bit[1] GP21 Bit[2] GP22 Bit[3] GP23 Bit[4] GP24 Bit[5] GP25 Bit[6] GP26 Bit[7] GP27

NAME/DEFAULT	REGISTER OFFSET (TYPE)	DESCRIPTION
GPDIR3 Default = 0x00 on VTR POR	0x12 (R/W)	GPIO Direction Register 3 0 = Input 1 = Output Bit[0] GP30 Bit[1] GP31 Bit[2] GP32 Bit[3] GP33 Bit[4] GP34 Bit[5] GP35 Bit[6] GP36 Bit[7] GP37
GPDIR4 Default = 0x00 on VTR POR	0x13 (R/W)	GPIO Direction Register 4 0 = Input 1 = Output Bit[0] GP50 Bit[1] GP51 Bit[2] GP52 Bit[3] GP53 Bit[4] GP54 Bit[5] GP55 Bit[6] GP56 Bit[7] GP57
GPOT1 Default = 0x00 on VTR POR	0x14 (R/W)	GPIO Output Type 1 0 = Push-Pull 1 = Open-Drain Bit[0] GP10 Bit[1] GP11 Bit[2] GP12 Bit[3] GP13 Bit[4] GP14 Bit[5] GP15 Bit[6] GP16 Bit[7] GP17
GPOT2 Default = 0x00 on VTR POR	0x15 (R/W)	GPIO Output Type 2 0 = Push-Pull 1 = Open-Drain Bit[0] GP20 Bit[1] GP21 Bit[2] GP22 Bit[3] GP23 Bit[4] GP24 Bit[5] GP25 Bit[6] GP26 Bit[7] GP27

NAME/DEFAULT	REGISTER OFFSET (TYPE)	DESCRIPTION
GPOT3 Default = 0x00 on VTR POR	0x16 (R/W)	GPIO Output Type 3 0 = Push-Pull 1 = Open-Drain Bit[0] GP30 Bit[1] GP31 Bit[2] GP32 Bit[3] GP33 Bit[4] GP34 Bit[5] GP35 Bit[6] GP36 Bit[7] GP37
GPOT4 Default = 0x00 on VTR POR	0x17 (R/W)	GPIO Output Type 4 0 = Push-Pull 1 = Open-Drain Bit[0] GP50 Bit[1] GP51 Bit[2] GP52 Bit[3] GP53 Bit[4] GP54 Bit[5] GP55 Bit[6] GP56 Bit[7] GP57
GP1 Default = 0x00 on VTR POR	0x18 (R/W)	GPIO Data Register 1 Reflects the state of the GPx pin if the GPIO is configured as input. Controls the state of the GPx pin if the GPIO is configured as output. Bit[0] GP10 Bit[1] GP11 Bit[2] GP12 Bit[3] GP13 Bit[4] GP14 Bit[5] GP15 Bit[6] GP16 Bit[7] GP17
GP2 Default = 0x00 on VTR POR	0x19 (R/W)	GPIO Data Register 2 Reflects the state of the GPx pin if the GPIO is configured as input. Controls the state of the GPx pin if the GPIO is configured as output. Bit[0] GP20 Bit[1] GP21 Bit[2] GP22 Bit[3] GP23 Bit[4] GP24 Bit[5] GP25 Bit[6] GP26 Bit[7] GP27

NAME/DEFAULT	REGISTER OFFSET (TYPE)	DESCRIPTION
GP3 Default = 0x00 on VTR POR	0x1A (R/W)	GPIO Data Register 3 Reflects the state of the GPx pin if the GPIO is configured as input. Controls the state of the GPx pin if the GPIO is configured as output. Bit[0] GP30 Bit[1] GP31 Bit[2] GP32 Bit[3] GP33 Bit[4] GP34 Bit[5] GP35 Bit[6] GP36 Bit[7] GP37
GP4 Default = 0x00 on VTR POR	0x1B (R/W)	GPIO Data Register 4 Reflects the state of the GPx pin if the GPIO is configured as input. Controls the state of the GPx pin if the GPIO is configured as output. Bit[0] GP50 Bit[1] GP51 Bit[2] GP52 Bit[3] GP53 Bit[4] GP54 Bit[5] GP55 Bit[6] GP56 Bit[7] GP57
GPMSK1 Default = 0x00 on VTR POR	0x1C (R/W)	GPIO Mask Register 1 0 = UnMasked 1 = Masked Bit[0] GP10 Bit[1] GP11 Bit[2] GP12 Bit[3] GP13 Bit[4] GP14 Bit[5] GP15 Bit[6] GP16 Bit[7] GP17
GPMSK2 Default = 0x00 on VTR POR	0x1D (R/W)	GPIO Mask Register 2 0 = UnMasked 1 = Masked Bit[0] GP20 Bit[1] GP21 Bit[2] GP22 Bit[3] GP23 Bit[4] GP24 Bit[5] GP25 Bit[6] GP26 Bit[7] GP27

NAME/DEFAULT	REGISTER OFFSET (TYPE)	DESCRIPTION
GPMSK3 Default = 0x00 on VTR POR	0x1E (R/W)	GPIO Mask Register 3 0 = UnMasked 1 = Masked Bit[0] GP30 Bit[1] GP31 Bit[2] GP32 Bit[3] GP33 Bit[4] GP34 Bit[5] GP35 Bit[6] GP36 Bit[7] GP37
GPMSK4 Default = 0x00 on VTR POR	0x1F (R/W)	GPIO Mask Register 4 0 = UnMasked 1 = Masked Bit[0] GP50 Bit[1] GP51 Bit[2] GP52 Bit[3] GP53 Bit[4] GP54 Bit[5] GP55 Bit[6] GP56 Bit[7] GP57

Chapter 19 Operational Description

19.1 Maximum Guaranteed Ratings

Operating Temperature Range	0°C to +70°C
Storage Temperature Range	-55° to +150°C
Lead Temperature Range	Refer to JEDEC Spec. J-STD-020
Maximum V_{CC}	+5.5V
Positive Voltage on any pin, with respect to Ground	$V_{CC}+10\%V$
Positive Voltage on any pin, with respect to Ground	-0.3V

Note: Stresses above those listed above and below could cause permanent damage to the device. This is a stress rating only and functional operation of the device at any other condition above those indicated in the operation sections of this specification is not implied. When powering this device from laboratory or system power supplies, it is important that the Absolute Maximum Ratings not be exceeded or device failure can result. Some power supplies exhibit voltage spikes on their outputs when the AC power is switched on or off. In addition, voltage transients on the AC power line may appear on the DC output. If this possibility exists, it is suggested that a clamp circuit be used.

19.2 DC Electrical Characteristics

($T_A = 0^{\circ}C - 70^{\circ}C$, $V_{CC} = +3.3 V \pm 10\%$)

PARAMETER	SYMBOL	MIN	TYP	MAX	UNITS	COMMENTS
I Type Input Buffer						
Low Input Level	V_{IL}			0.8	V	TTL Levels
High Input Level	V_{IH}	2.0		5.5	V	TTL Levels
IS Type Input Buffer						
Low Input Level	V_{IL}			0.8	V	Schmitt Trigger
High Input Level	V_{IH}	2.2		5.5	V	Schmitt Trigger
Schmitt Trigger Hysteresis	V_{HYS}		100		mV	
IS2 Type Input Buffer						
Low Input Level	V_{IL}			0.8	V	Schmitt Trigger
High Input Level	V_{IH}	2.1		5.5	V	Schmitt Trigger
Schmitt Trigger Hysteresis	V_{HYS}		250		mV	

PARAMETER	SYMBOL	MIN	TYP	MAX	UNITS	COMMENTS
ICLK and OCLK Type Buffer						
Load Capacitance	CL		TBD		pF	Use a 24 MHz parallel resonant crystal oscillator. The load capacitors are seen by the crystal as two capacitors in series and is approximately $CL = X / Y$ $X = CL1 * CL2$ $Y = CL1 + CL2$. For example, a 12.5pF crystal should use two 25pF capacitors for proper loading.
Equivalent Series Resistance	ESR			TBD	Ω	
O8 Type Buffer						
Low Output Level	V_{OL}			0.4	V	$I_{OL} = 8mA$
High Output Level	V_{OH}	2.4			V	$I_{OH} = -4mA$
OD8 Type Buffer						
Low Output Level	V_{OL}			0.4	V	$I_{OL} = 8mA$
High Output Level	V_{OH}			$V_{CC}+10\%$	V	Open Drain; $V_{CC}=3.3V$ (5V Max)
O12 Type Buffer						
Low Output Level	V_{OL}			0.4	V	$I_{OL} = 12mA$
High Output Level	V_{OH}	2.4			V	$I_{OH} = -6mA$
OD12 Type Buffer						
Low Output Level	V_{OL}			0.4	V	$I_{OL} = 12mA$
High Output Level	V_{OH}			$V_{CC}+10\%$	V	Open Drain; $V_{CC}=3.3V$ (5V Max)
OD14 Type Buffer						
Low Output Level	V_{OL}			0.4	V	$I_{OL} = 14mA$
High Output Level	V_{OH}			$V_{CC}+10\%$	V	Open Drain; $V_{CC}=3.3V$
OP14 Type Buffer						
Low Output Level	V_{OL}			0.4	V	$I_{OL} = 14mA$
High Output Level	V_{OH}	2.4			V	$I_{OH} = -14mA$

PARAMETER	SYMBOL	MIN	TYP	MAX	UNITS	COMMENTS
IO8 Type Buffer						
Low Input Level	V_{IL}			0.8	V	TTL Levels
High Input Level	V_{IH}	2.0		5.5	V	TTL Levels
Low Output Level	V_{OL}			0.4	V	$I_{OL} = 8\text{mA}$
High Output Level	V_{OH}	2.4			V	$I_{OH} = -4\text{mA}$
IS2OD12 Type Buffer						
Low Input Level	V_{IL}			0.8	V	Schmitt Trigger
High Input Level	V_{IH}	2.1		5.5	V	Schmitt Trigger
Schmitt Trigger Hysteresis	V_{HYS}		250		mV	
Low Output Level	V_{OL}			0.4	V	$I_{OL} = 12\text{mA}$
High Output Level	V_{OH}			$V_{CC}+10\%$	V	Open Drain; $V_{CC}=3.3\text{V}$ (5V Max)
IOP14 Type Buffer						
Low Input Level	V_{IL}			0.8	V	TTL Levels
High Input Level	V_{IH}	2.0		5.5	V	TTL Levels
Low Output Level	V_{OL}			0.4	V	$I_{OL} = 14\text{mA}$
High Output Level	V_{OH}	2.4			V	$I_{OH} = -14\text{mA}$
PCI Type Buffers (PCI_ICLK, PCI_I, PCI_O, PCI_IO, PCI_IOD)	3.3V PCI 2.1 Compatible.					
Leakage Current (ALL – except IS2, IS2OD12 and PCI Buffers)						(Note 19.1)
Input High Current	$I_{LEAK_{IH}}$			10	μA	$V_{IN} = V_{CC}$
Input Low Current	$I_{LEAK_{IL}}$			-10	μA	$V_{IN} = 0\text{V}$
Leakage Current (IS2 and IS2OD12)						(Note 19.1)
Input High Current	$I_{LEAK_{IH}}$			5	μA	$V_{IN} = V_{CC}$
Input Low Current	$I_{LEAK_{IL}}$			-5	μA	$V_{IN} = 0\text{V}$

PARAMETER	SYMBOL	MIN	TYP	MAX	UNITS	COMMENTS
Backdrive Protect/ChiProtect (All except PCI Buffers)						
Input High Current	ILEAK _{IH}			10*	μA	V _{CC} = 0V V _{IN} = 5.5V Max
Input Low Current	ILEAK _{IL}			-10*	μA	V _{IN} = 0V * For IS2 and IS2OD8 this value is 5 / -5 uA.
5V Tolerant Pins (All except PCI Buffers)						
Input High Current	ILEAK _{IH}			10*	μA	V _{CC} = 0V V _{IN} = 5.5V Max
Input Low Current	ILEAK _{IL}			-10*	μA	V _{IN} = 0V * For IS2 and IS2OD8 this value is 5 / -5 uA.
Leakage Current (PCI Buffers)						
Input High Current	ILEAK _{IH}			10	μA	V _{CC} = 0V and V _{CC} = 3.3V V _{IN} = 3.6V Max
Input Low Current	ILEAK _{IL}			-10	μA	V _{IN} = 0V
V_{CC} Supply Current Active	I _{CC}			10	mA	All outputs open, all inputs transitioning from/to 0V to/from 3.3V).
V_{TR} Supply Current Active	I _{TR}			20	mA	All outputs, all inputs transitioning from/to 0V to/from 3.3V).

Notes:

- Voltages are measured from the local ground potential, unless otherwise specified.
- Typicals are at TA=25°C and represent most likely parametric norm.
- The maximum allowable power dissipation at any temperature is PD = (TJmax - TA) / QJA.
- Timing specifications are tested at the TTL logic levels, VIL=0.4V for a falling edge and VIH=2.4V for a rising edge. TRI-STATE output voltage is forced to 1.4V.

Note 19.1 All leakage currents are measured with all pins in high impedance.

CAPACITANCE T_A = 25°C; f_c = 1MHz; V_{CC} = 3.3V ±10%

PARAMETER	SYMBOL	LIMITS			UNIT	TEST CONDITION
		MIN	TYP	MAX		
Clock Input Capacitance	C _{IN}			20	pF	All pins except pin under test tied to AC ground
Input Capacitance	C _{IN}			10	pF	
Output Capacitance	C _{OUT}			20	pF	

Note: The input capacitance of a port is measured at the connector pins.

Chapter 20 Timing Diagrams

For the Timing Diagrams shown, the following capacitive loads are used on outputs.

NAME	CAPACITANCE TOTAL (PF)
SER_IRQ	50
LAD[3:0]	50
nLDRQ	50
PD[0:7]	240
nSTROBE	240
nALF	240
SLCTIN	240
TXD	50
nCLKRUN	50
SDAT	240
SCLK	240

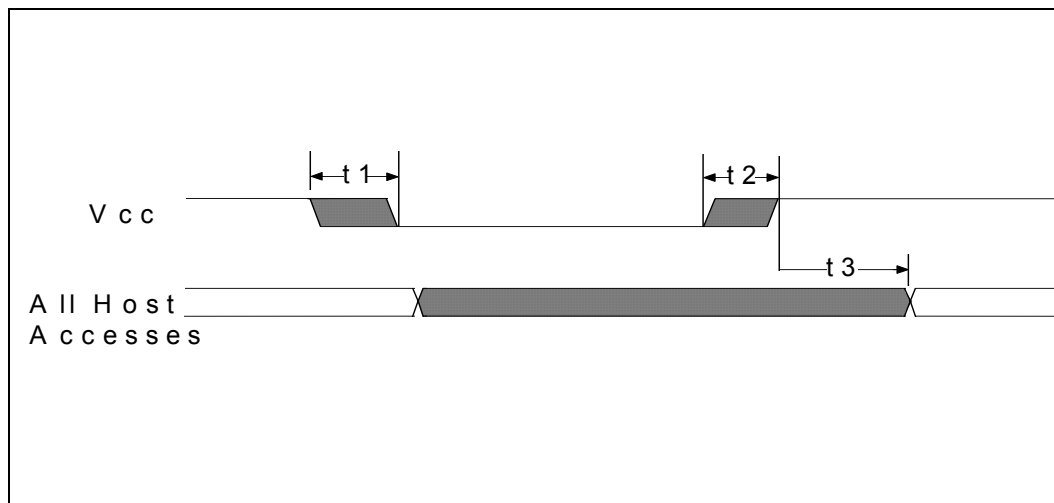

Figure 20.1 - POWER-UP TIMING

NAME	DESCRIPTION	MIN	TYP	MAX	UNITS
t1	Vcc Slew from 2.7V to 0V	300			μs
t2	Vcc Slew from 0V to 2.7V	100			μs
t3	All Host Accesses After Powerup (Note 4.1)	125		500	μs

Note 20.1 Internal write-protection period after Vcc passes 2.7 volts on power-up

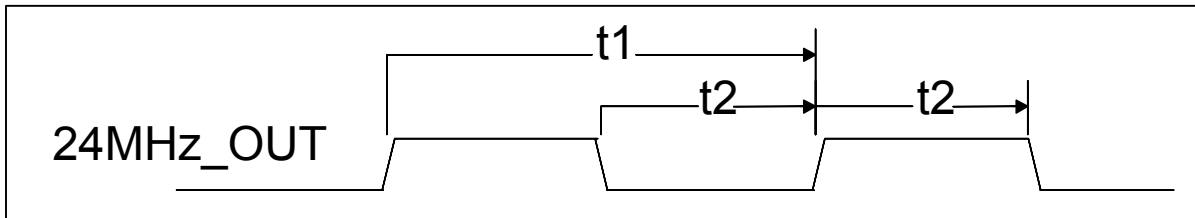

Figure 20.2 – 24MHz_OUT CLOCK TIMING

NAME	DESCRIPTION	MIN	TYP	MAX	UNITS
t1	Clock Cycle Time for 24MHZ		41.66		ns
t2	Clock High Time/Low Time for 24MHz	TBD	20.83		ns
	Clock Rise Time/Fall Time (not shown)			TBD	ns

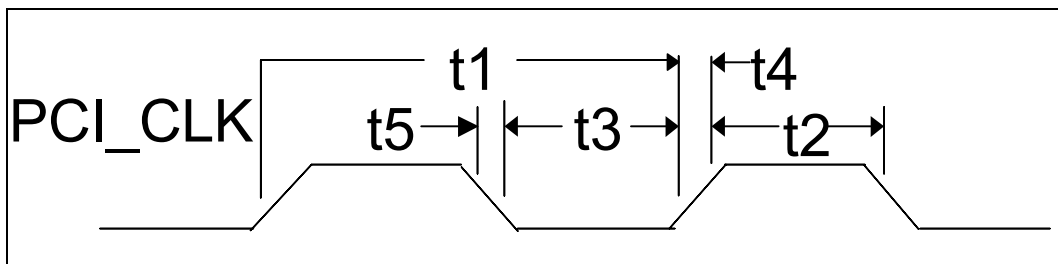

Figure 20.3 – PCI CLOCK TIMING

NAME	DESCRIPTION	MIN	TYP	MAX	UNITS
t1	Period	30		33.3	nsec
t2	High Time	12			nsec
t3	Low Time	12			nsec
t4	Rise Time			3	nsec
t5	Fall Time			3	nsec

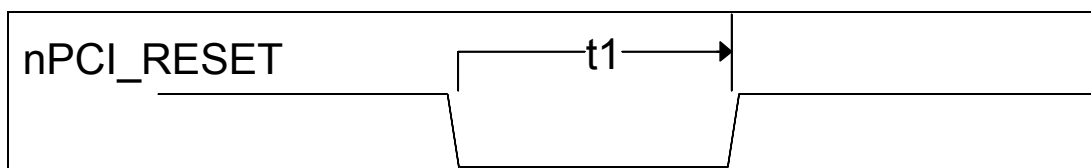
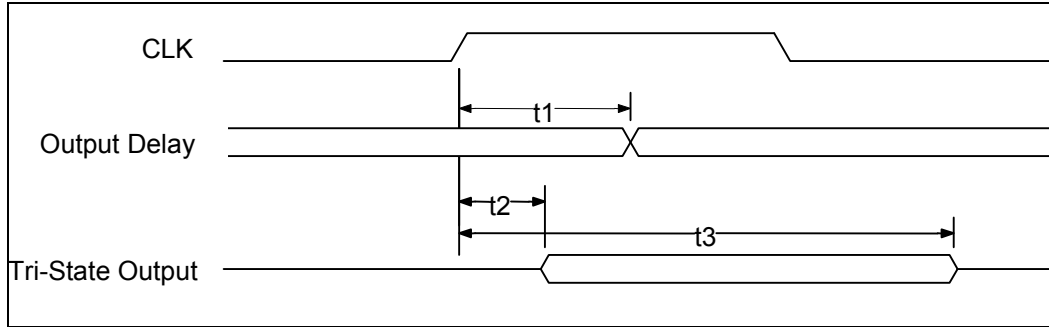
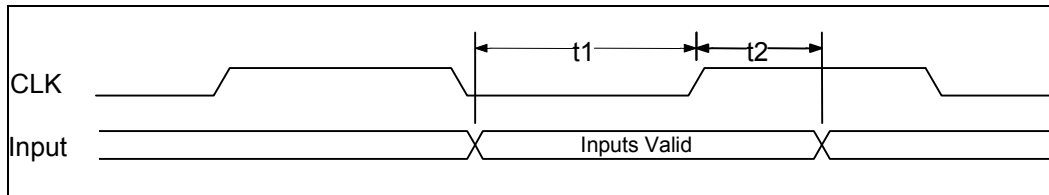

Figure 20.4 - RESET TIMING

NAME	DESCRIPTION	MIN	TYP	MAX	UNITS
t1	nPCI_RESET width	1			ms

Figure 20.5 – Output Timing Measurement Conditions, LPC Signals

NAME	DESCRIPTION	MIN	TYP	MAX	UNITS
t1	CLK to Signal Valid Delay – Bused Signals	2		11	ns
t2	Float to Active Delay	2		11	ns
t3	Active to Float Delay			28	ns

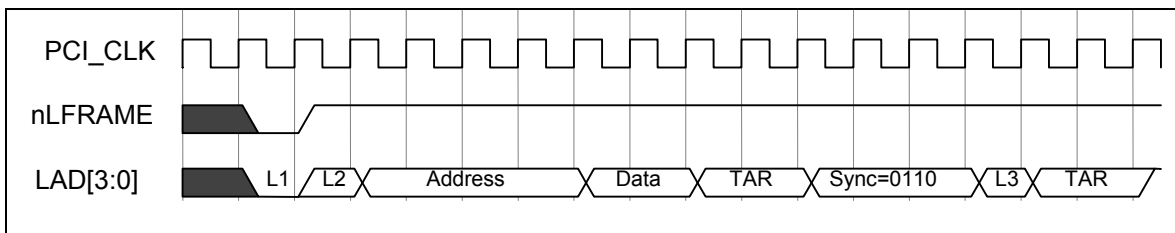
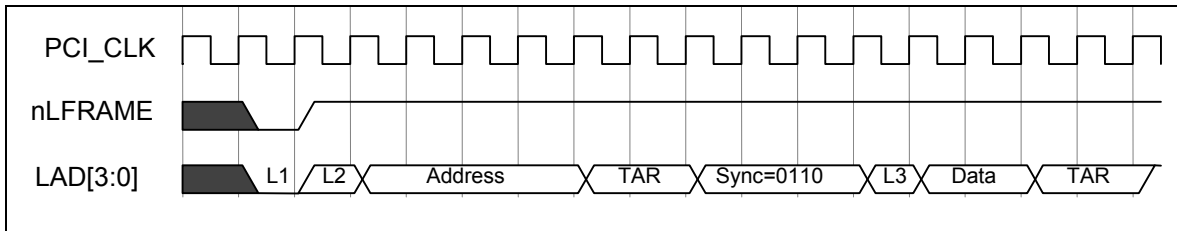

Figure 20.6 – Input Timing Measurement Conditions, LPC Signals

NAME	DESCRIPTION	MIN	TYP	MAX	UNITS
t1	Input Set Up Time to CLK – Bused Signals	7			ns
t2	Input Hold Time from CLK	0			ns



Note: L1=Start; L2=CYCTYP+DIR; L3=Sync of 0000

Figure 20.7 – LPC I/O Write



Note: L1=Start; L2=CYCTYP+DIR; L3=Sync of 0000

Figure 20.8 – LPC I/O Read

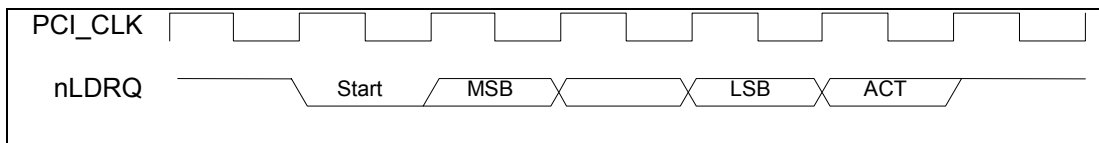
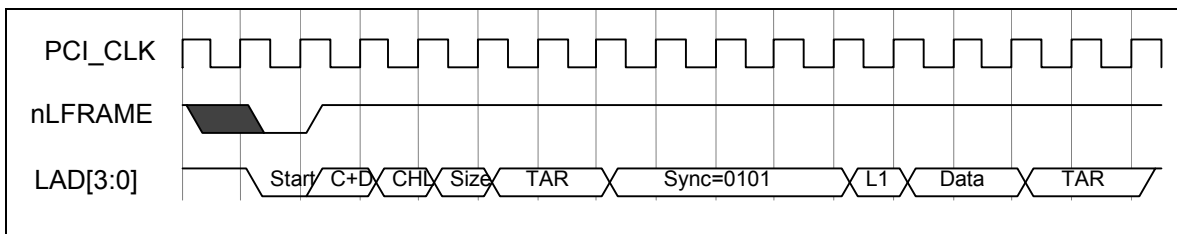
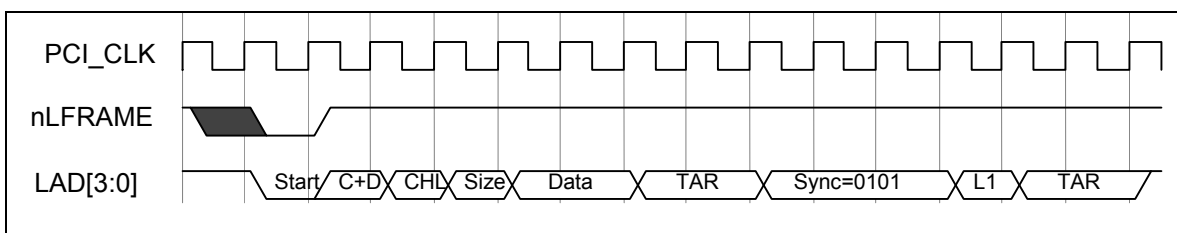

Figure 20.9 – DMA Request Assertion Through nLDRQ



Note: L1=Sync of 0000

Figure 20.10 – LPC DMA Write (First Byte)



Note: L1=Sync of 0000

Figure 20.11 – LPC DMA Read (First Byte)

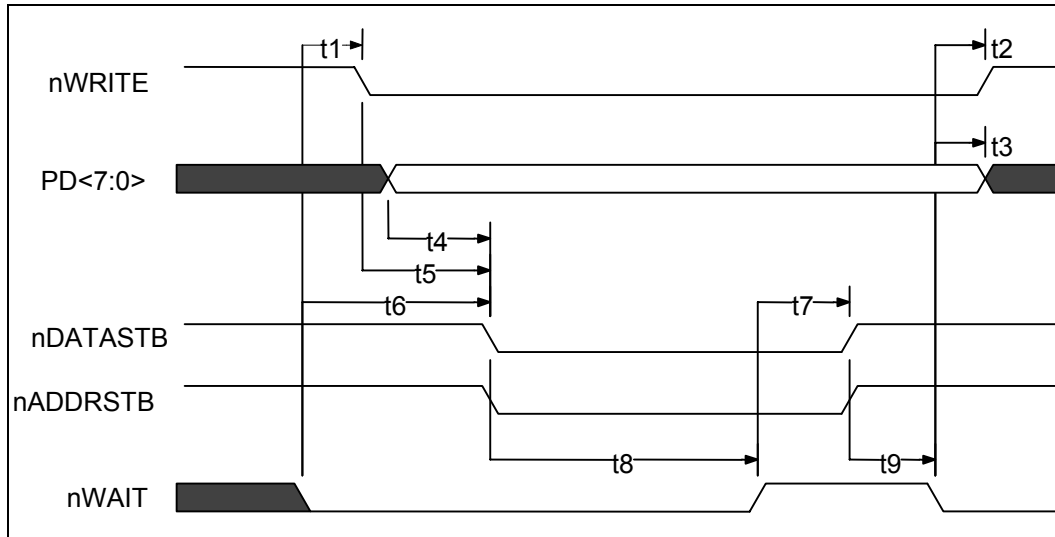
Figure 20.12 – EPP 1.9 Data or Address Write Cycle

NAME	DESCRIPTION	MIN	TYP	MAX	UNITS
t1	nWAIT Asserted to nWRITE Asserted (Note 20.2)	60		185	ns
t2	nWAIT Asserted to nWRITE Change (Note 20.2)	60		185	ns
t3	nWAIT Asserted to PDATA Invalid (Note 20.2)	0			ns
t4	PDATA Valid to Command Asserted	10			ns
t5	nWRITE to Command Asserted	5		35	ns
t6	nWAIT Asserted to Command Asserted (Note 20.2)	60		210	ns
t7	nWAIT Deasserted to Command Deasserted (Note 20.2)	60		190	ns
t8	Command Asserted to nWAIT Deasserted	0		10	μs
t9	Command Deasserted to nWAIT Asserted	0			ns

Note 20.2 nWAIT must be filtered to compensate for ringing on the parallel bus cable. WAIT is considered to have settled after it does not transition for a minimum of 50 nsec.

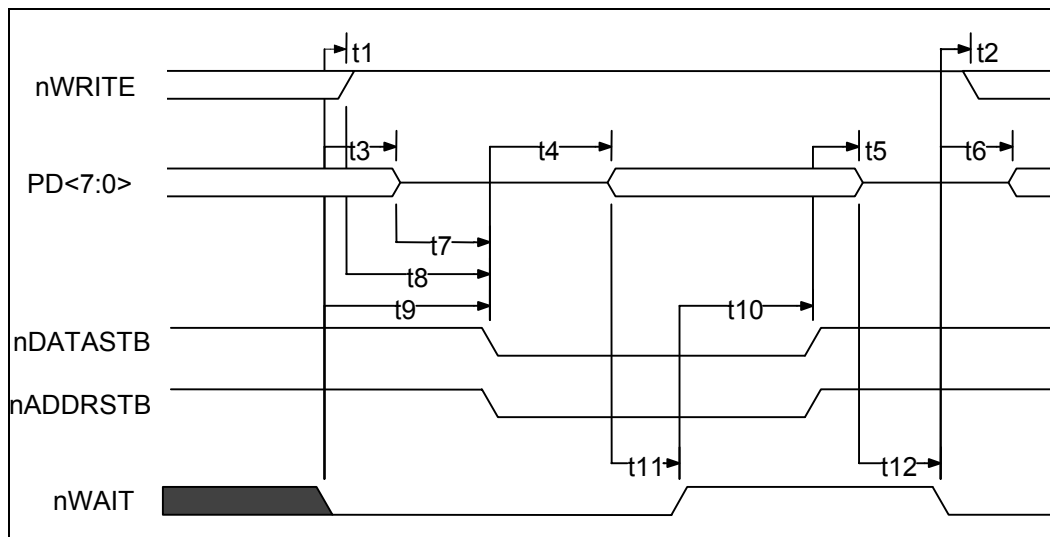
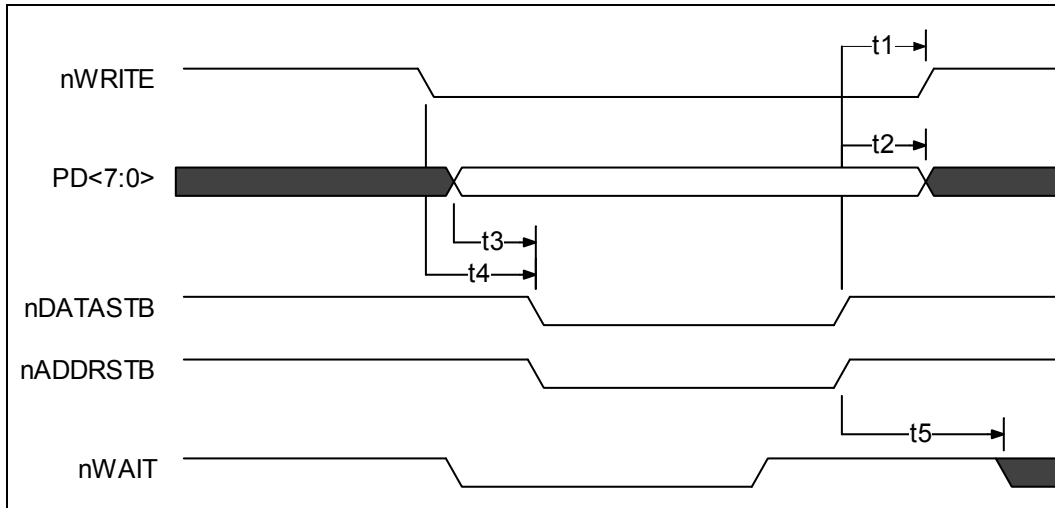

Figure 20.13 – EPP 1.9 Data or Address Read Cycle

NAME	DESCRIPTION	MIN	TYP	MAX	UNITS
t1	nWAIT Asserted to nWRITE Deasserted	0		185	ns
t2	nWAIT Asserted to nWRITE Modified (Note 20.3, Note 20.4)	60		190	ns
t3	nWAIT Asserted to PDATA Hi-Z (Note 20.3)	60		180	ns
t4	Command Asserted to PDATA Valid	0			ns
t5	Command Deasserted to PDATA Hi-Z	0			ns
t6	nWAIT Asserted to PDATA Driven (Note 20.3)	60		190	ns
t7	PDATA Hi-Z to Command Asserted	0		30	ns
t8	nWRITE Deasserted to Command	1			ns
t9	nWAIT Asserted to Command Asserted	0		195	ns
t10	nWAIT Deasserted to Command Deasserted (Note 20.3)	60		180	ns
t11	PDATA Valid to nWAIT Deasserted	0			ns
t12	PDATA Hi-Z to nWAIT Asserted	0			μs

Note 20.3 nWAIT is considered to have settled after it does not transition for a minimum of 50 ns.

Note 20.4 When not executing a write cycle, EPP nWRITE is inactive high.

Figure 20.14 – EPP 1.7 Data or Address Write Cycle

NAME	DESCRIPTION	MIN	TYP	MAX	UNITS
t1	Command Deasserted to nWRITE Change	0		40	ns
t2	Command Deasserted to PDATA Invalid	50			ns
t3	PDATA Valid to Command Asserted	10		35	ns
t4	nWRITE to Command	5		35	ns
t5	Command Deasserted to nWAIT Deasserted	0			ns

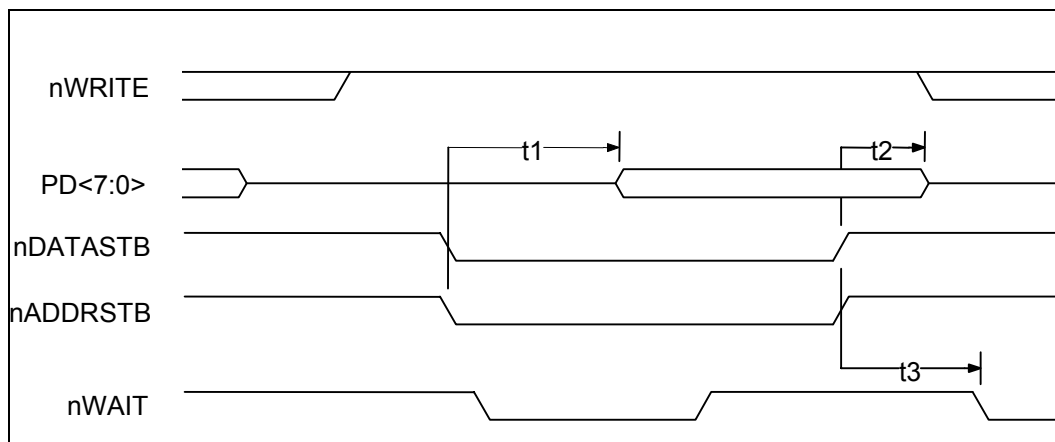
Figure 20.15 – EPP 1.7 Data or Address Read Cycle

NAME	DESCRIPTION	MIN	TYP	MAX	UNITS
t1	Command Asserted to PDATA Valid	0			ns
t2	Command Deasserted to PDATA Hi-Z	0			ns
t3	Command Deasserted to nWAIT Deasserted	0			ns

20.1 ECP Parallel Port Timing

20.1.1 Parallel Port FIFO (Mode 101)

The standard parallel port is run at or near the peak 500KBytes/sec allowed in the forward direction using DMA. The state machine does not examine nACK and begins the next transfer based on Busy. Refer to Figure 20.16.

20.1.2 ECP Parallel Port Timing

The timing is designed to allow operation at approximately 2.0 Mbytes/sec over a 15ft cable. If a shorter cable is used then the bandwidth will increase.

20.1.3 Forward-Idle

When the host has no data to send it keeps HostClk (nStrobe) high and the peripheral will leave PeriphClk (Busy) low.

20.1.4 Forward Data Transfer Phase

The interface transfers data and commands from the host to the peripheral using an interlocked PeriphAck and HostClk. The peripheral may indicate its desire to send data to the host by asserting nPeriphRequest.

The Forward Data Transfer Phase may be entered from the Forward-Idle Phase. While in the Forward Phase the peripheral may asynchronously assert the nPeriphRequest (nFault) to request that the channel be reversed. When the peripheral is not busy it sets PeriphAck (Busy) low. The host then sets HostClk (nStrobe) low when it is prepared to send data. The data must be stable for the specified setup time prior to the falling edge of HostClk. The peripheral then sets PeriphAck (Busy) high to acknowledge the handshake. The host then sets HostClk (nStrobe) high. The peripheral then accepts the data and sets PeriphAck (Busy) low, completing the transfer. This sequence is shown in Figure 20.17.

The timing is designed to provide 3 cable round-trip times for data setup if Data is driven simultaneously with HostClk (nStrobe).

20.1.5 Reverse-Idle Phase

The peripheral has no data to send and keeps PeriphClk high. The host is idle and keeps HostAck low.

20.1.6 Reverse Data Transfer Phase

The interface transfers data and commands from the peripheral to the host using an interlocked HostAck and PeriphClk.

The Reverse Data Transfer Phase may be entered from the Reverse-Idle Phase. After the previous byte has been accepted the host sets HostAck (nALF) low. The peripheral then sets PeriphClk (nACK) low when it has data to send. The data must be stable for the specified setup time prior to the falling edge of PeriphClk. When the host is ready to accept a byte it sets HostAck (nALF) high to acknowledge the

handshake. The peripheral then sets PeriphClk (nACK) high. After the host has accepted the data it sets HostAck (nALF) low, completing the transfer. This sequence is shown in Figure 20.18.

20.1.7 Output Drivers

To facilitate higher performance data transfer, the use of balanced CMOS active drivers for critical signals (Data, HostAck, HostClk, PeriphAck, PeriphClk) are used in ECP Mode. Because the use of active drivers can present compatibility problems in Compatible Mode (the control signals, by tradition, are specified as open-drain), the drivers are dynamically changed from open-drain to push-pull. The timing for the dynamic driver change is specified in then IEEE 1284 Extended Capabilities Port Protocol and ISA Interface Standard, Rev. 1.14, July 14, 1993, available from Microsoft. The dynamic driver change must be implemented properly to prevent glitching the outputs.

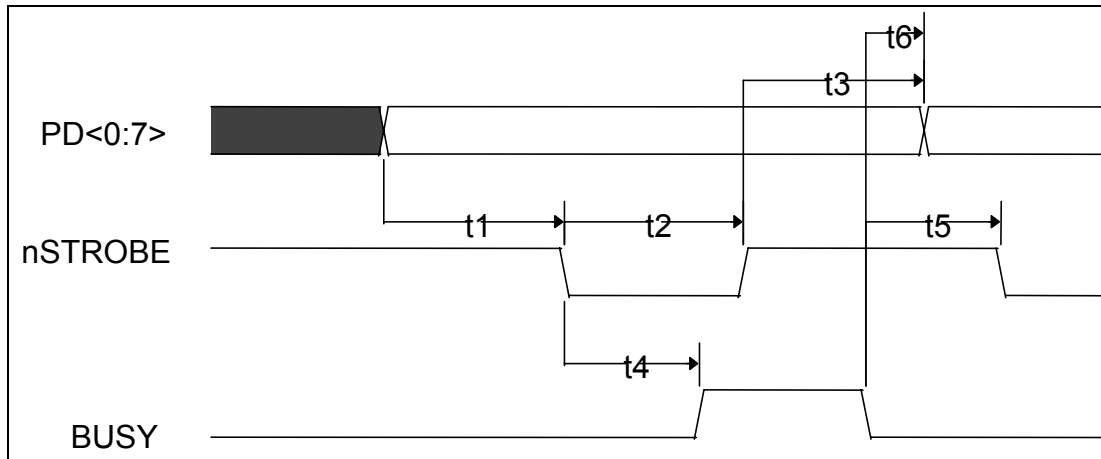

Figure 20.16 – Parallel Port FIFO Timing

NAME	DESCRIPTION	MIN	TYP	MAX	UNITS
t1	PDATA Valid to nSTROBE Active	600			ns
t2	nSTROBE Active Pulse Width	600			ns
t3	PDATA Hold from nSTROBE Inactive (Note 20.5)	450			ns
t4	nSTROBE Active to BUSY Active			500	ns
t5	BUSY Inactive to nSTROBE Active	680			ns
t6	BUSY Inactive to PDATA Invalid (Note 20.5)	80			ns

Note 20.5 The data is held until BUSY goes inactive or for time t3, whichever is longer. This only applies if another data transfer is pending. If no other data transfer is pending, the data is held indefinitely.

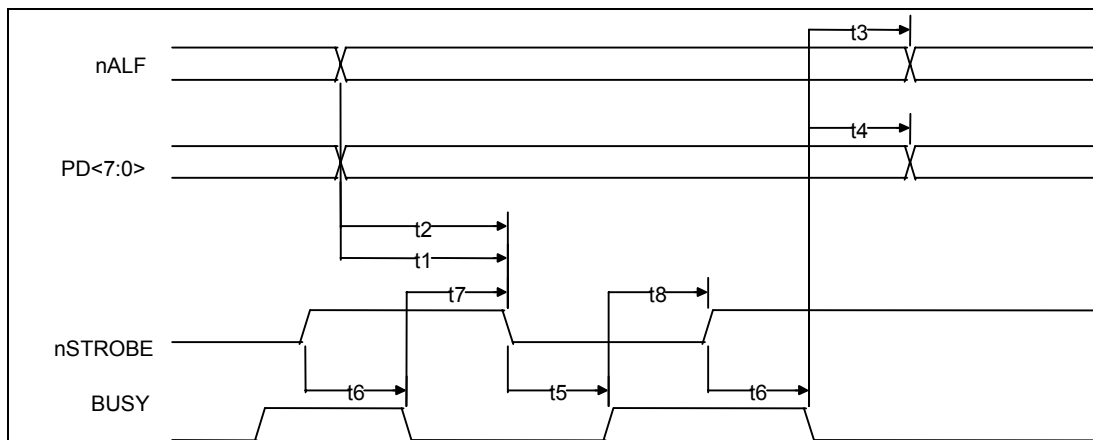
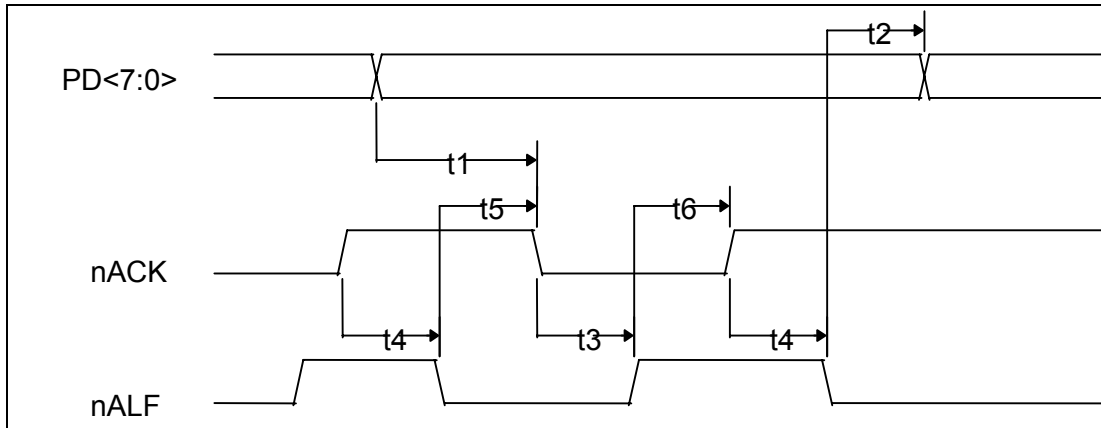

Figure 20.17 - ECP Parallel Port Forward Timing

NAME	DESCRIPTION	MIN	TYP	MAX	UNITS
t1	nALF Valid to nSTROBE Asserted	0		60	ns
t2	PDATA Valid to nSTROBE Asserted	0		60	ns
t3	BUSY Deasserted to nALF Changed (Note 20.6, Note 20.7)	80		180	ns
t4	BUSY Deasserted to PDATA Changed (Note 20.6, Note 20.7)	80		180	ns
t5	nSTROBE Asserted to Busy Asserted	0			ns
t6	nSTROBE Deasserted to Busy Deasserted	0			ns
t7	BUSY Deasserted to nSTROBE Asserted (Note 20.6, Note 20.7)	80		200	ns
t8	BUSY Asserted to nSTROBE Deasserted (Note 20.7)	80		180	ns

Note 20.6 Maximum value only applies if there is data in the FIFO waiting to be written out.

Note 20.7 BUSY is not considered asserted or deasserted until it is stable for a minimum of 75 to 130 ns.

Figure 20.18 - ECP Parallel Port Reverse Timing

NAME	DESCRIPTION	MIN	TYP	MAX	UNITS
t1	PDATA Valid to nACK Asserted	0			ns
t2	nALF Deasserted to PDATA Changed	0			ns
t3	nACK Asserted to nALF Deasserted (Note 20.8, Note 20.9)	80		200	ns
t4	nACK Deasserted to nALF Asserted (Note 20.9)	80		200	ns
t5	nALF Asserted to nACK Asserted	0			ns
t6	nALF Deasserted to nACK Deasserted	0			ns

Note 20.8 Maximum value only applies if there is room in the FIFO and terminal count has not been received. ECP can stall by keeping nALF low.

Note 20.9 nACK is not considered asserted or deasserted until it is stable for a minimum of 75 to 130 ns.

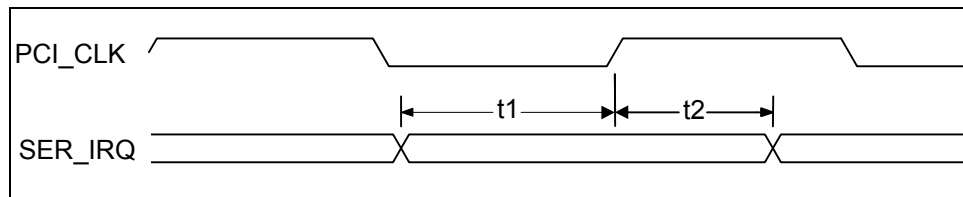

Figure 20.19 – SER_IRQ Setup and Hold Time

NAME	DESCRIPTION	MIN	TYP	MAX	UNITS
t1	SER_IRQ Setup Time to PCI_CLK Rising	7			nsec
t2	SER_IRQ Hold Time to PCI_CLK Rising	0			nsec

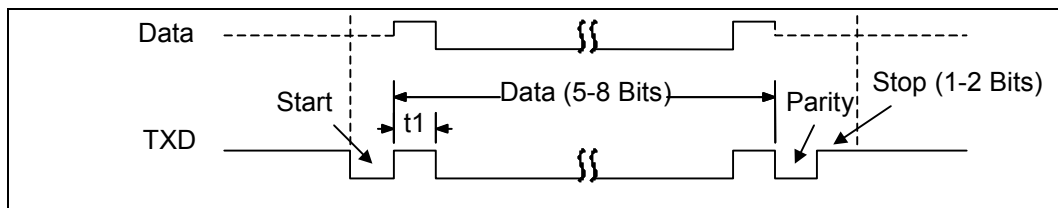
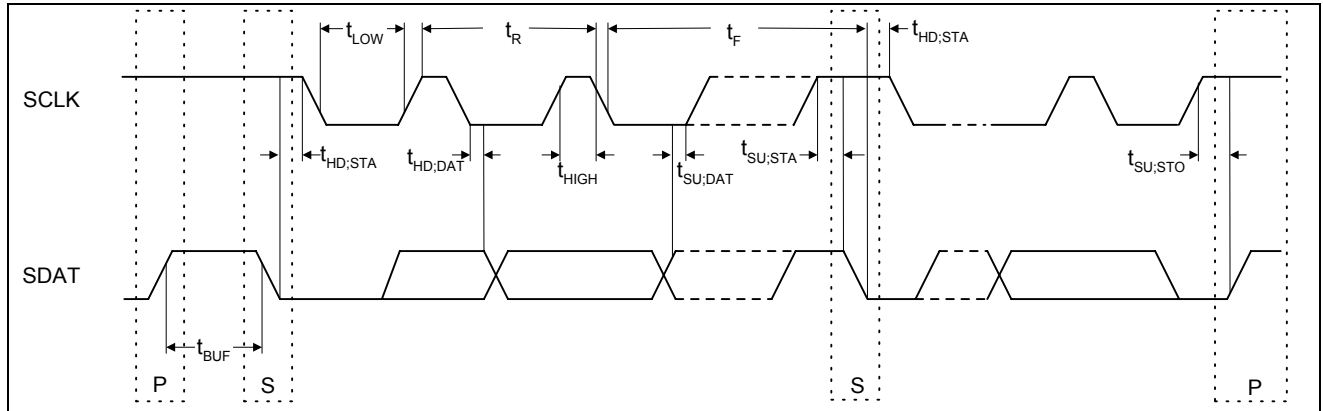

Figure 20.20 – Serial Port Data

NAME	DESCRIPTION	MIN	TYP	MAX	UNITS
t1	Serial Port Data Bit Time		t_{BR}^{-1}		nsec

Note: t_{BR} is 1/Baud Rate. The Baud Rate is programmed through the divisor latch registers. Baud Rates have percentage errors indicated in the “Baud Rate” table in the “Serial Port” section.

Figure 20.21 – SMBus Timing

SYMBOL	PARAMETER	LIMITS		UNITS	COMMENTS
		MIN	MAX		
Fsmb	SMB Operating Frequency	10	100	kHz	
Tbuf	Bus free time between Stop and Start Condition	4.7		μs	
T _{hd:sta}	Hold time after (Repeated) Start Condition. After this period, the first clock is generated.	4.0		μs	
T _{su:sta}	Repeated Start Condition setup time	4.7		μs	
T _{su:sto}	Stop Condition setup time	4.0		μs	
T _{hd:dat}	Data hold time	0		ns	
T _{su:dat}	Data setup time	250		ns	
T _{timeout}	Max. Clock low time	25	35	ms	(Note 20.10)
T _{low}	Clock low period	4.7		μs	
T _{high}	Clock high period	4.0	50	μs	(Note 20.11)
T _{low: sext}	Cumulative clock low extend time (slave device)		25	ms	
T _{low: mext}	Cumulative clock low extend time (master device)		10	ms	
T _f	Clock/Data Fall Time		300	ns	
T _r	Clock/Data Rise Time		1000	ns	

Note 20.10 A device will timeout when any clock low exceeds this value.

Note 20.11 T_{HIGH} Max provides a simple guaranteed method for devices to detect bus idle conditions.

Chapter 21 XNOR-Chain Test Mode

The LPC47N237 provides board test capability through the implementation of XNOR chain. See following sub-sections.

XNOR-Chain test structure allows users to confirm that all pins are in contact with the motherboard during assembly and test operations. See Figure 21.1 below. When the chip is in the XNOR chain test mode, setting the state of any of the input pins to the opposite of its current state will cause the output of the chain to toggle.

The XNOR-Chain test structure must be activated to perform these tests. When the XNOR-Chain is activated, the LPC47N237 pin functions are disconnected from the device pins, which all become input pins except for one output pin at the end of XNOR-Chain.

The tests that are performed when the XNOR-Chain test structure is activated require the board-level test hardware to control the device pins and observe the results at the XNOR-Chain output pin.

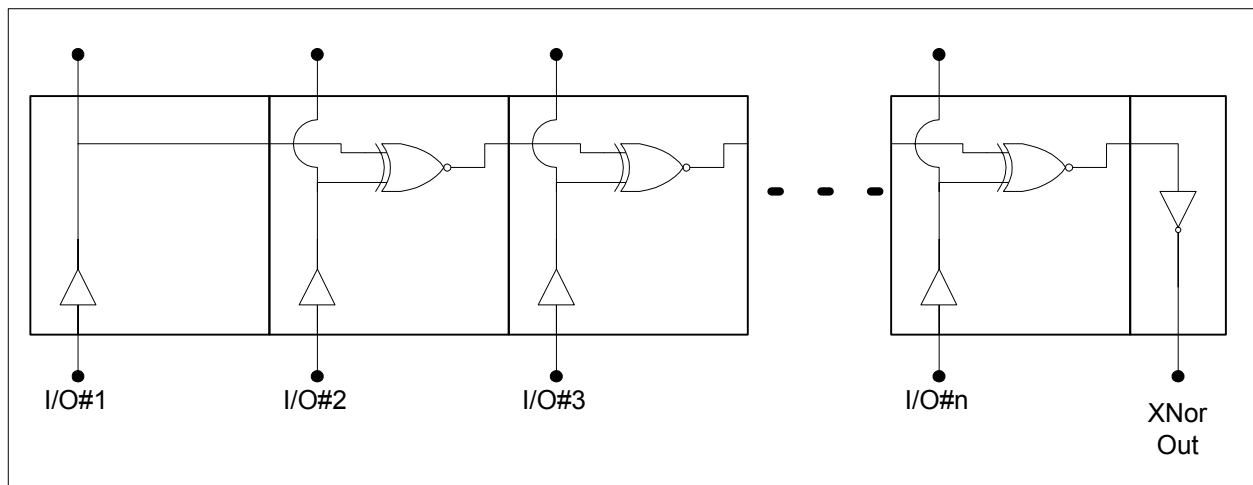

Figure 21.1 – XNOR-CHAIN TEST STRUCTURE

21.1 Entering and Exiting Test Mode

21.1.1 XNOR-Chain test mode can be entered as follows:

On the rising (deasserting) edge of nPCI_RESET, drive nLFRAME low and drive LAD[0] low.

21.1.2 XNOR-Chain test mode can be exited as follows:

On the rising (deasserting) edge of nPCI_RESET, drive either nLFRAME or LAD[0] high.

The nPCI_RESET pin is not included in the XNOR-Chain. The XNOR-Chain output pin# is 17, nIO_PME. See the following subsections for more details.

21.2 Pin List of XNOR Chain

Pins 1 to 100 on the chip are inputs to the first XNOR chain, with the exception of the following:

1. VCC (pins 13, 48, 53, 65 and 93) and VTR (pins 1, 18, 32 and 63).
2. VSS (pins 7, 19, 31, 39, 56, 60 and 76).
3. nIO_PME (pin 17) This is the chain output.
4. nPCI_RESET (pin 26).
5. XTAL1 (pin 61) and XTAL2 (pin 62)

To put the chip in the first XNOR chain test mode, tie LAD0 (pin 10) and nLFRAME (pin 24) low. Then toggle nPCI_RESET (pin 26) from a low to a high state. Once the chip is put into XNOR chain test mode, LAD0 (pin 20) and nLFRAME (pin 24) become part of the chain.

To exit the first XNOR chain test mode tie LAD0 (pin 20) or nLFRAME (pin 24) high. Then toggle nPCI_RESET (pin 26) from a low to a high state. A VCC POR will also cause the XNOR chain test mode to be exited. To verify the test mode has been exited, observe the output at nIO_PME (pin 17). Toggling any of the input pins in the chain should not cause its state to change.

21.3 Setup of XNOR Chain

Warning: Ensure power supply is off during setup.

1. Connect VSS (pins 7, 19, 31, 39, 56, 60 and 76) to ground.
2. Connect VCC (pins 13, 48, 53, 65 and 93) and VTR (pins 1, 18, 32 and 63) to VCC (3.3V).
3. Connect an oscilloscope or voltmeter to nIO_PME (pin 17).
4. All other pins should be tied to ground.

21.4 Testing Procedure

1. Turn power on.
2. With LAD0 (pin 20) and nLFRAME (pin 24), low, bring nPCI_RESET (pin 26) high. The chip is now in XNOR chain test mode. At this point, all inputs to the first XNOR chain are low. The output, on nIO_PME (pin 17), should also be low. Refer to INITIAL CONFIG on TRUTH TABLE 1.
3. Bring pin 100 high. The output on nIO_PME (pin 17) should go high. Refer to STEP ONE on TRUTH TABLE 1.
4. In descending pin order, bring each input high. The output should switch states each time an input is toggled. Continue until all inputs are high. The output on nIO_PME should now be low. Refer to END CONFIG on TRUTH TABLE 1.
5. The current state of the chip is now represented by INITIAL CONFIG in TRUTH TABLE 2.
6. Each input should now be brought low, starting at pin one and continuing in ascending order. Continue until all inputs are low. The output on nIO_PME should now be low. Refer to TRUTH TABLE 2.
7. To exit test mode, tie LAD0 (pin 20) OR nLFRAME (pin 24) high, and toggle nPCI_RESET from a low to a high state.

TRUTH TABLE 1 - Toggling Inputs in Descending Order

	PIN 100	PIN 99	PIN 98	PIN 97	PIN 96	PIN ...	PIN 1	OUTPUT PIN 17
INITIAL CONFIG	L	L	L	L	L	L	L	L
STEP 1	H	L	L	L	L	L	L	H
STEP 2	H	H	L	L	L	L	L	L
STEP 3	H	H	H	L	L	L	L	H
STEP 4	H	H	H	H	L	L	L	L
STEP 5	H	H	H	H	H	L	L	H
...
STEP N-1	H	H	H	H	H	H	L	H
END CONFIG	H	H	H	H	H	H	H	L

TRUTH TABLE 2 - Toggling Inputs in Ascending Order

	PIN 1	PIN 2	PIN 3	PIN 4	PIN 5	PIN ...	PIN 100	OUTPUT PIN 17
INITIAL CONFIG	H	H	H	H	H	H	H	L
STEP 1	L	H	H	H	H	H	H	H
STEP 2	L	L	H	H	H	H	H	L
STEP 3	L	L	L	H	H	H	H	H
STEP 4	L	L	L	L	H	H	H	L
STEP 5	L	L	L	L	L	H	H	H
...
STEP N-1	L	L	L	L	L	L	H	H
END CONFIG	L	L	L	L	L	L	L	L

Chapter 22 Package Outline

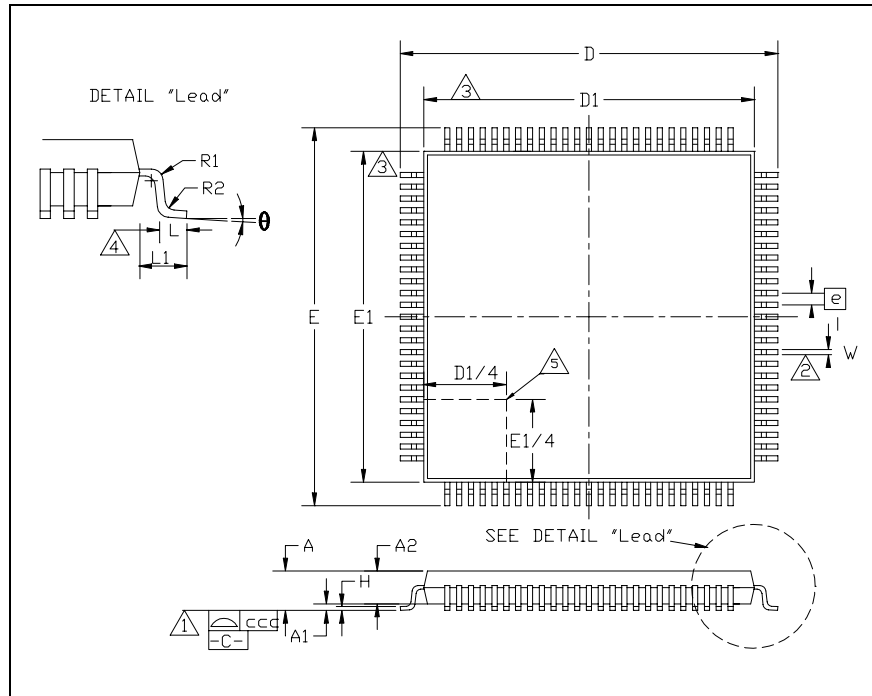

Figure 22.1 – 100 Pin TQFP Package Outline

Table 22.1 – 100 Pin TQFP Package Parameters

	MIN	NOMINAL	MAX	REMARKS
A	~	~	1.60	Overall Package Height
A1	0.05	~	0.15	Standoff
A2	1.35	~	1.45	Body Thickness
D	15.80	~	16.20	X Span
D1	13.90	~	14.10	X body Size
E	15.80	~	16.20	Y Span
E1	13.90	~	14.10	Y body Size
H	0.09	~	0.20	Lead Frame Thickness
L	0.45	0.60	0.75	Lead Foot Length
L1	~	1.00	~	Lead Length
e	0.50 Basic			Lead Pitch
θ	0°	~	7°	Lead Foot Angle
W	0.17	0.22	0.27	Lead Width
R1	0.08	~	~	Lead Shoulder Radius
R2	0.08	~	0.20	Lead Foot Radius
ccc	~	~	0.08	Coplanarity

Notes:

1. Controlling Unit: millimeter.
2. Tolerance on the position of the leads is ± 0.04 mm maximum.
3. Package body dimensions D1 and E1 do not include the mold protrusion. Maximum mold protrusion is 0.25 mm.
4. Dimension for foot length L measured at the gauge plane 0.25 mm above the seating plane.
5. Details of pin 1 identifier are optional but must be located within the zone indicated.