

# SIEMENS

## Microcomputer Components

8-Bit CMOS Single-Chip Microcontroller

# SAB 80C517/80C537

Data Sheet 04.95

## High-Performance 8-Bit CMOS Single-Chip Microcontroller

**SAB 80C517/80C537**

### Advanced Information

SAB 80C517  
SAB 80C537

Microcontroller with factory mask-programmable ROM  
Microcontroller for external ROM

- Versions for 12 MHz and 16 MHz operating frequency
- 8 K × 8 ROM (SAB 80C517 only)
- 256 × 8 on-chip RAM
- Superset of SAB 80C51 architecture:
  - 1 μs instruction cycle time at 12 MHz
  - 750 ns instruction cycle time at 16 MHz
  - 256 directly addressable bits Boolean processor
  - 64 Kbyte external data and program memory addressing
- Four 16-bit timer/counters
- Powerful 16-bit compare/capture unit (CCU) with up to 21 high-speed or PWM output channels and 5 capture inputs
- Versatile "fail-safe" provisions
- Fast 32-bit division, 16-bit 2 multiplication, 32-bit normalize and shift by peripheral MUL/DIV unit (MDU)
- Eight data pointers for external memory addressing
- Fourteen interrupt vectors, four priority levels selectable
- 8-bit A/D converter with 12 multiplexed inputs and programmable ref. voltages
- Two full duplex serial interfaces
- Fully upward compatible with SAB 80C515
- Extended power saving modes
- Nine ports: 56 I/O lines, 12 input lines
- Two temperature ranges available:
  - 0 to 70 °C
  - 40 to 85 °C
- Plastic packages: P-LCC-84, P-MQFP-100-2

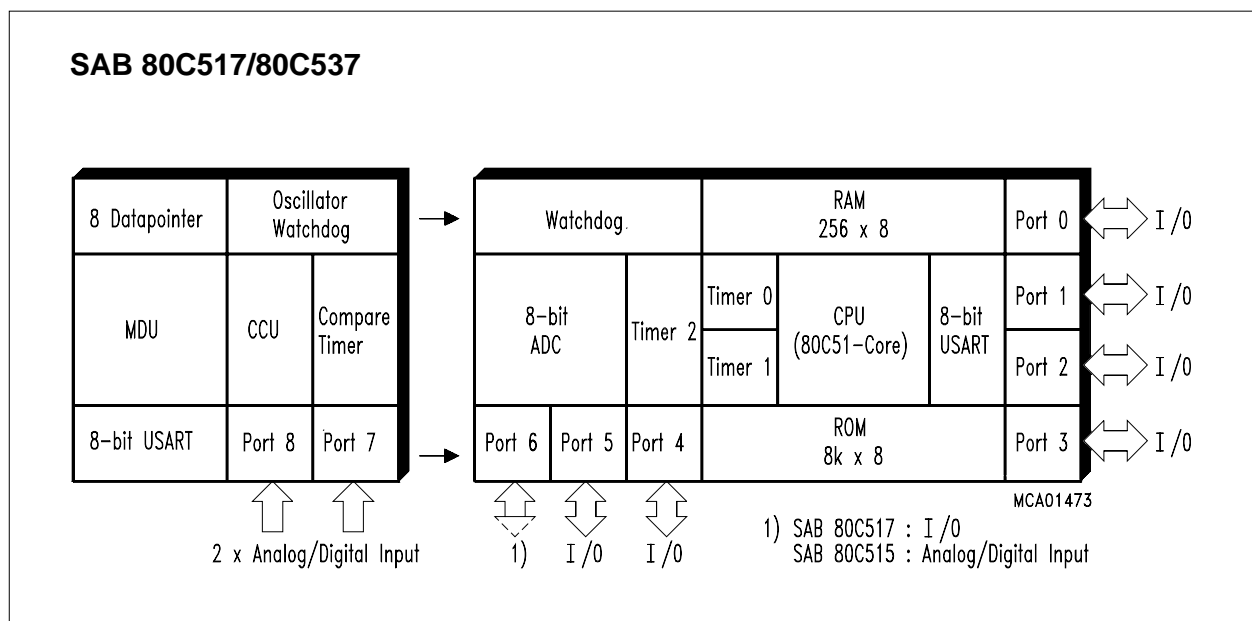

The SAB 80C517/80C537 is a high-end member of the Siemens SAB 8051 family of microcontrollers. It is designed in Siemens ACMOS technology and based on the SAB 8051 architecture. ACMOS is a technology which combines high-speed and density characteristics with low-power consumption or dissipation.

While maintaining all the SAB 80C515 features and operating characteristics the SAB 80C517 is expanded in its arithmetic capabilities, "fail-safe" characteristics, analog signal processing and timer capabilities. The SAB 80C537 is identical with the SAB 80C517 except that it lacks the on-chip program memory. The SAB 80C517/SAB 80C537 is supplied in a 84 pin plastic leaded chip carrier package (P-LCC-84) and in a 100-pin plastic quad metric flat package (P-MQFP-100-2).

### Ordering Information

Type	Ordering Code	Package	Description 8-bit CMOS Microcontroller
SAB 80C517-N	Q67120-C397	P-LCC-84	with factory mask-programmable ROM, 12 MHz
SAB 80C517-M	TBD	P-MQFP-100-2	
SAB 80C537-N	Q67120-C452	P-LCC-84	for external memory, 12 MHz
SAB 80C537-M	TBD	P-MQFP-100-2	
SAB 80C517-N-T40/85	Q67120-C483	P-LCC-84	with factory mask-programmable ROM, 12 MHz, ext. temperature – 40 to 85 °C
SAB 80C517-M-T40/85	TBD	P-MQFP-100-2	
SAB 80C537-N-T40/85	Q67120-C484	P-LCC-84	for external ROM, 12 MHz, ext. temperature – 40 to 85 °C
SAB 80C537-M-T40/85	TBD	P-MQFP-100-2	
SAB 80C517-N16	Q67120-C723	P-LCC-84	with mask-programmable ROM, 16 MHz ext. temperature – 40 to 110 °C
SAB 80C517-M16	TBD	P-MQFP-100-2	
SAB 80C537-N16	Q67120-C722	P-LCC-84	for external memory, 16 MHz
SAB 80C537-M16	TBD	P-MQFP-100-2	
SAB 80C517-N16-T40/85	Q67120-C724	P-LCC-84	with mask-programmable ROM, 16 MHz ext. temperature – 40 to 85 °C
SAB 80C517-16-N-T40/85	Q67120-C725	P-LCC-84	with factory mask-programmable ROM, 12 MHz

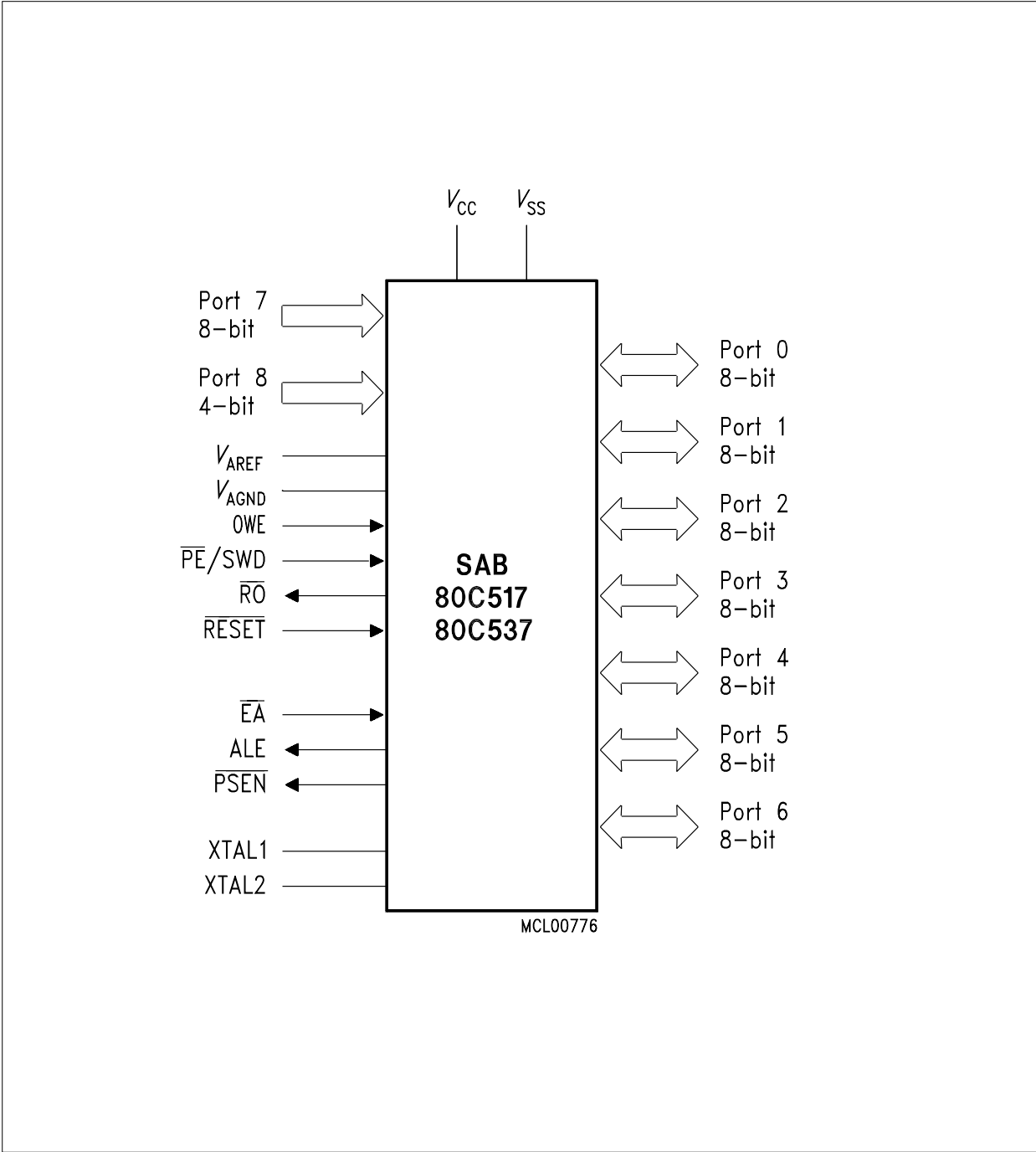

Logic Symbol

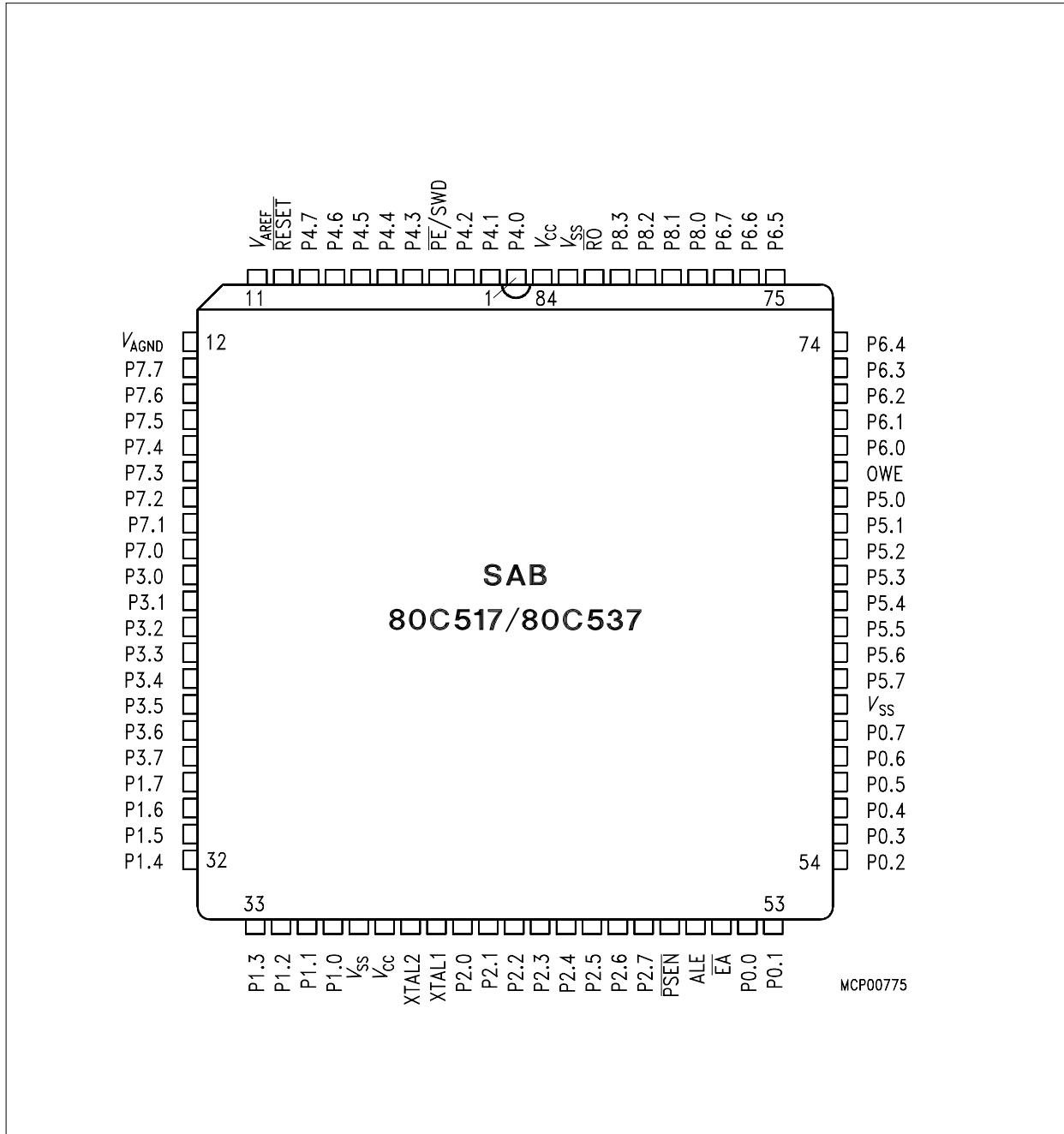

**Pin Configuration**  
(P-LCC-84)

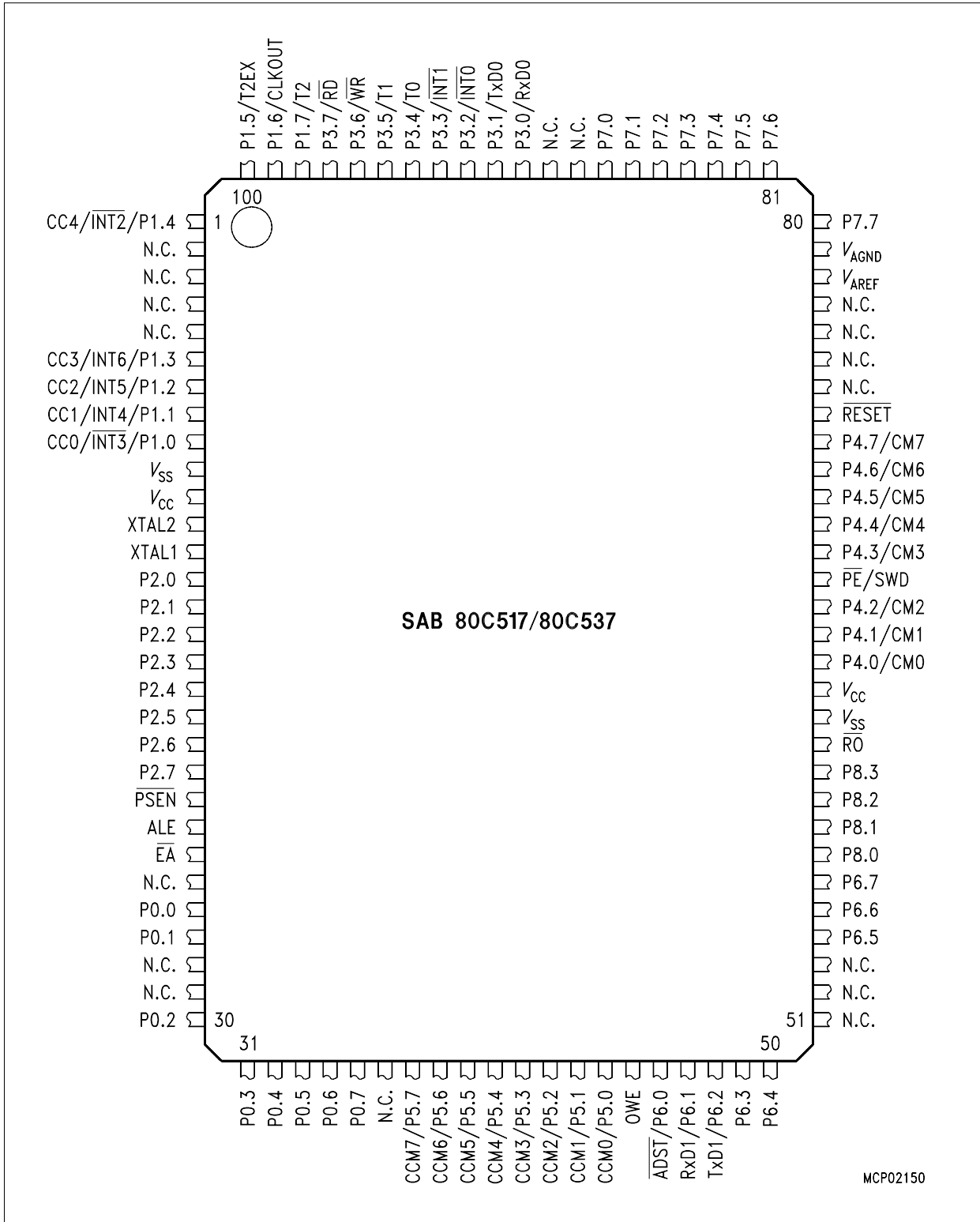

MCP02150

**Pin Configuration**  
(P-MQFP-100-2)

## Pin Definitions and Functions

Symbol	Pin Number		I/O *)	Function
	P-LCC-84	P-MQFP-100-2		
P4.0 – P4.7	1– 3, 5 – 9	64 - 66, 68 - 72	I/O	<p><b>Port 4</b> is a bidirectional I/O port with internal pull-up resistors. Port 4 pins that have 1 s written to them are pulled high by the internal pull-up resistors, and in that state can be used as inputs. As inputs, port 4 pins being externally pulled low will source current (<math>I_{IL}</math>, in the DC characteristics) because of the internal pull-up resistors.</p> <p>This port also serves alternate compare functions. The secondary functions are assigned to the pins of port 4 as follows:</p> <ul style="list-style-type: none"> <li>– CM0 (P4.0): Compare Channel 0</li> <li>– CM1 (P4.1): Compare Channel 1</li> <li>– CM2 (P4.2): Compare Channel 2</li> <li>– CM3 (P4.3): Compare Channel 3</li> <li>– CM4 (P4.4): Compare Channel 4</li> <li>– CM5 (P4.5): Compare Channel 5</li> <li>– CM6 (P4.6): Compare Channel 6</li> <li>– CM7 (P4.7): Compare Channel 7</li> </ul>
$\overline{PE}/SWD$	4	67	I	<p><b>Power saving modes enable/ Start Watchdog Timer</b></p> <p>A low level on this pin allows the software to enter the power down, idle and slow down mode. In case the low level is also seen during reset, the watchdog timer function is off on default.</p> <p>Use of the software controlled power saving modes is blocked, when this pin is held on high level. A high level during reset performs an automatic start of the watchdog timer immediately after reset. When left unconnected this pin is pulled high by a weak internal pull-up resistor.</p>

\* I = Input  
O = Output

### Pin Definitions and Functions (cont'd)

Symbol	Pin Number		I/O *)	Function
	P-LCC-84	P-MQFP-100-2		
$\overline{\text{RESET}}$	10	73	I	$\overline{\text{RESET}}$ A low level on this pin for the duration of one machine cycle while the oscillator is running resets the SAB 80C517. A small internal pull-up resistor permits power-on reset using only a capacitor connected to $V_{SS}$ .
$V_{\text{AREF}}$	11	78		<b>Reference voltage</b> for the A/D converter.
$V_{\text{AGND}}$	12	79		<b>Reference ground</b> for the A/D converter.
P7.7 -P7.0	13 - 20	80 - 87	I	<b>Port 7</b> is an 8-bit unidirectional input port. Port pins can be used for digital input, if voltage levels meet the specified input high/low voltages, and for the lower 8-bit of the multiplexed analog inputs of the A/D converter, simultaneously.

\* I = Input  
O = Output



Pin Definitions and Functions (cont'd)

Symbol	Pin Number		I/O *)	Function
	P-LCC-84	P-MQFP-100-2		
P3.0 - P3.7	21 - 28	90 - 97	I/O	<p><b>Port 3</b> is a bidirectional I/O port with internal pull-up resistors. Port 3 pins that have 1 s written to them are pulled high by the internal pull-up resistors, and in that state can be used as inputs. As inputs, port 3 pins being externally pulled low will source current (<math>I_{IL}</math>, in the DC characteristics) because of the internal pull-up resistors. Port 3 also contains the interrupt, timer, serial port 0 and external memory strobe pins that are used by various options. The output latch corresponding to a secondary function must be programmed to a one (1) for that function to operate. The secondary functions are assigned to the pins of port 3, as follows:</p> <ul style="list-style-type: none"> <li>– <math>R \times D0</math> (P3.0): receiver data input (asynchronous) or data input/output (synchronous) of serial interface</li> <li>– <math>T \times D0</math> (P3.1): transmitter data output (asynchronous) or clock output (synchronous) of serial interface 0</li> <li>– <math>\overline{INT0}</math> (P3.2): interrupt 0 input/timer 0 gate control</li> <li>– <math>\overline{INT1}</math> (P3.3): interrupt 1 input/timer 1 gate control</li> <li>– T0 (P3.4): counter 0 input</li> <li>– T1 (P3.5): counter 1 input</li> <li>– <math>\overline{WR}</math> (P3.6): the write control signal latches the data byte from port 0 into the external data memory</li> <li>– <math>\overline{RD}</math> (P3.7): the read control signal enables the external data memory to port 0</li> </ul>

\* I = Input  
O = Output

Pin Definitions and Functions (cont'd)

Symbol	Pin Number		I/O *)	Function
	P-LCC-84	P-MQFP-100-2		
P1.7 - P1.0	29 - 36	98 - 100, 1, 6 - 9	I/O	<p><b>Port 1</b> is a bidirectional I/O port with internal pull-up resistors. Port 1 pins that have 1 s written to them are pulled high by the internal pull-up resistors, and in that state can be used as inputs. As inputs, port 1 pins being externally pulled low will source current (<math>I_{IL}</math>, in the DC characteristics) because of the internal pull-up resistors. It is used for the low order address byte during program verification. It also contains the interrupt, timer, clock, capture and compare pins that are used by various options. The output latch must be programmed to a one (1) for that function to operate (except when used for the compare functions). The secondary functions are assigned to the port 1 pins as follows:</p> <ul style="list-style-type: none"> <li>- <math>\overline{INT3}/CC0</math> (P1.0): <math>\overline{interrupt\ 3\ input/compare\ 0\ output\ /capture\ 0\ input}</math></li> <li>- <math>\overline{INT4}/CC1</math> (P1.1): <math>\overline{interrupt\ 4\ input\ /compare\ 1\ output\ /capture\ 1\ input}</math></li> <li>- <math>\overline{INT5}/CC2</math> (P1.2): <math>\overline{interrupt\ 5\ input\ /compare\ 2\ output\ /capture\ 2\ input}</math></li> <li>- <math>\overline{INT6}/CC3</math> (P1.3): <math>\overline{interrupt\ 6\ input\ /compare\ 3\ output\ /capture\ 3\ input}</math></li> <li>- <math>\overline{INT2}/CC4</math> (P1.4): <math>\overline{interrupt\ 2\ input\ /compare\ 4\ output\ /capture\ 4\ input}</math></li> <li>- T2EX (P1.5): timer 2 external reload trigger input</li> <li>- CLKOUT (P1.6): system clock output</li> <li>- T2 (P1.7): counter 2 input</li> </ul>

\* I = Input  
O = Output

## Pin Definitions and Functions (cont'd)

Symbol	Pin Number		I/O *)	Function
	P-LCC-84	P-MQFP-100-2		
XTAL2	39	12	–	<b>XTAL2</b> Input to the inverting oscillator amplifier and input to the internal clock generator circuits.
XTAL1	40	13	–	<b>XTAL1</b> Output of the inverting oscillator amplifier. To drive the device from an external clock source, XTAL2 should be driven, while XTAL1 is left unconnected. There are no requirements on the duty cycle of the external clock signal, since the input to the internal clocking circuitry is divided down by a divide-by-two flip-flop. Minimum and maximum high and low times as well as rise/fall times specified in the AC characteristics must be observed.
P2.0 - P2.7	41 - 48	14 - 21	I/O	<b>Port 2</b> is a bidirectional I/O port with internal pull-up resistors. Port 2 pins that have 1 s written to them are pulled high by the internal pull-up resistors, and in that state can be used as in-puts. As inputs, port 2 pins being externally pulled low will source current ( $I_{IL}$ , in the DC characteristics) because of the internal pull-up resistors. Port 2 emits the high-order address byte during fetches from external program memory and during accesses to external data memory that use 16-bit addresses (MOVX @DPTR). In this application it uses strong internal pull-up resistors when issuing 1 s. During accesses to external data memory that use 8-bit addresses (MOVX @Ri), port 2 issues the contents of the P2 special function register.

\* I = Input  
O = Output

## Pin Definitions and Functions (cont'd)

Symbol	Pin Number		I/O *)	Function
	P-LCC-84	P-MQFP-100-2		
$\overline{\text{PSEN}}$	49	22	O	The <b>Program Store Enable</b> output is a control signal that enables the external program memory to the bus during external fetch operations. It is activated every six oscillator periods except during external data memory accesses. Remains high during internal program execution.
ALE	50	23	O	The <b>Address Latch Enable</b> output is used for latching the address into external memory during normal operation. It is activated every six oscillator periods except during an external data memory access
$\overline{\text{EA}}$	51	24	I	<b>External Access Enable</b> When held at high level, instructions are fetched from the internal ROM when the PC is less than 8192. When held at low level, the SAB 80C517 fetches all instructions from external program memory. For the SAB 80C537 this pin must be tied low
P0.0 - P0.7	52 - 59	26 - 27, 30 - 35	I/O	<b>Port 0</b> is an 8-bit open-drain bidirectional I/O port. Port 0 pins that have 1 s written to them float, and in that state can be used as high-impedance inputs. Port 0 is also the multiplexed low-order address and data bus during accesses to external program or data memory. In this application it uses strong internal pull-up resistors when issuing 1 s. Port 0 also outputs the code bytes during program verification in the SAB 83C517. External pull-up resistors are required during program verification.

\* I = Input  
O = Output

## Pin Definitions and Functions (cont'd)

Symbol	Pin Number		I/O *)	Function
	P-LCC-84	P-MQFP-100-2		
P5.7 - P5.0	61 - 68	37 - 44	I/O	<p><b>Port 5</b> is a bidirectional I/O port with internal pull-up resistors. Port 5 pins that have 1 s written to them are pulled high by the internal pull-up resistors, and in that state can be used as inputs. As inputs, port 5 pins being externally pulled low will source current (<math>I_{IL}</math>, in the DC characteristics) because of the internal pull-up resistors. This port also serves the alternate function "Concurrent Compare". The secondary functions are assigned to the port 5 pins as follows:</p> <ul style="list-style-type: none"> <li>– CCM0 (P5.0): concurrent compare 0</li> <li>– CCM1 (P5.1): concurrent compare 1</li> <li>– CCM2 (P5.2): concurrent compare 2</li> <li>– CCM3 (P5.3): concurrent compare 3</li> <li>– CCM4(P5.4): concurrent compare 4</li> <li>– CCM5 (P5.5): concurrent compare 5</li> <li>– CCM6 (P5.6): concurrent compare 6</li> <li>– CCM7(P5.7): concurrent compare 7</li> </ul>
OWE	69	45	I	<p><b>Oscillator Watchdog Enable</b> A high level on this pin enables the oscillator watchdog. When left unconnected this pin is pulled high by a weak internal pull-up resistor. When held at low level the oscillator watchdog function is off.</p>

\* I = Input

O = Output

## Pin Definitions and Functions (cont'd)

Symbol	Pin Number		I/O *)	Function
	P-LCC-84	P-MQFP-100-2		
P6.0 - P6.7	70 - 77	46 - 50, 54 - 56	I/O	<p><b>Port 6</b> is a bidirectional I/O port with internal pull-up resistors. Port 6 pins that have 1 s written to them are pulled high by the internal pull-up resistors, and in that state can be used as inputs. As inputs, port 6 pins being externally pulled low will source current (<math>I_{IL}</math>, in the DC characteristics) because of the internal pull-up resistors. Port 6 also contains the external A/D converter control pin and the transmit and receive pins for serial channel 1. The output latch corresponding to a secondary function must be programmed to a one (1) for that function to operate. The secondary functions are assigned to the pins of port 6, as follows:</p> <ul style="list-style-type: none"> <li>– <math>\overline{ADST}</math> (P6.0): external A/D converter start pin</li> <li>– <math>R \times D1</math> (P6.1): receiver data input of serial interface 1</li> <li>– <math>T \times D1</math> (P6.2): transmitter data output of serial interface 1</li> </ul>
P8.0 - P8.3	78 - 81	57 - 60	I	<p><b>Port 8</b> is a 4-bit unidirectional input port. Port pins can be used for digital input, if voltage levels meet the specified input high/low voltages, and for the higher 4-bit of the multiplexed analog inputs of the A/D converter, simultaneously</p>

\* I = Input  
O = Output

## Pin Definitions and Functions (cont'd)

Symbol	Pin Number		I/O *)	Function
	P-LCC-84	P-MQFP-100-2		
$\overline{RO}$	82	61	O	<b>Reset Output</b> This pin outputs the internally synchronized reset request signal. This signal may be generated by an external hardware reset, a watchdog timer reset or an oscillator watch-dog reset. The reset output is active low.
$V_{SS}$	37,60, 83	10, 62	–	<b>Circuit ground potential</b>
$V_{CC}$	38,84	11, 63	–	<b>Supply Terminal</b> for all operating modes
N.C.	–	2 - 5, 25, 28 - 29, 36, 51 - 53, 74 - 77; 88 - 89	–	Not connected

\*) I = Input

O = Output

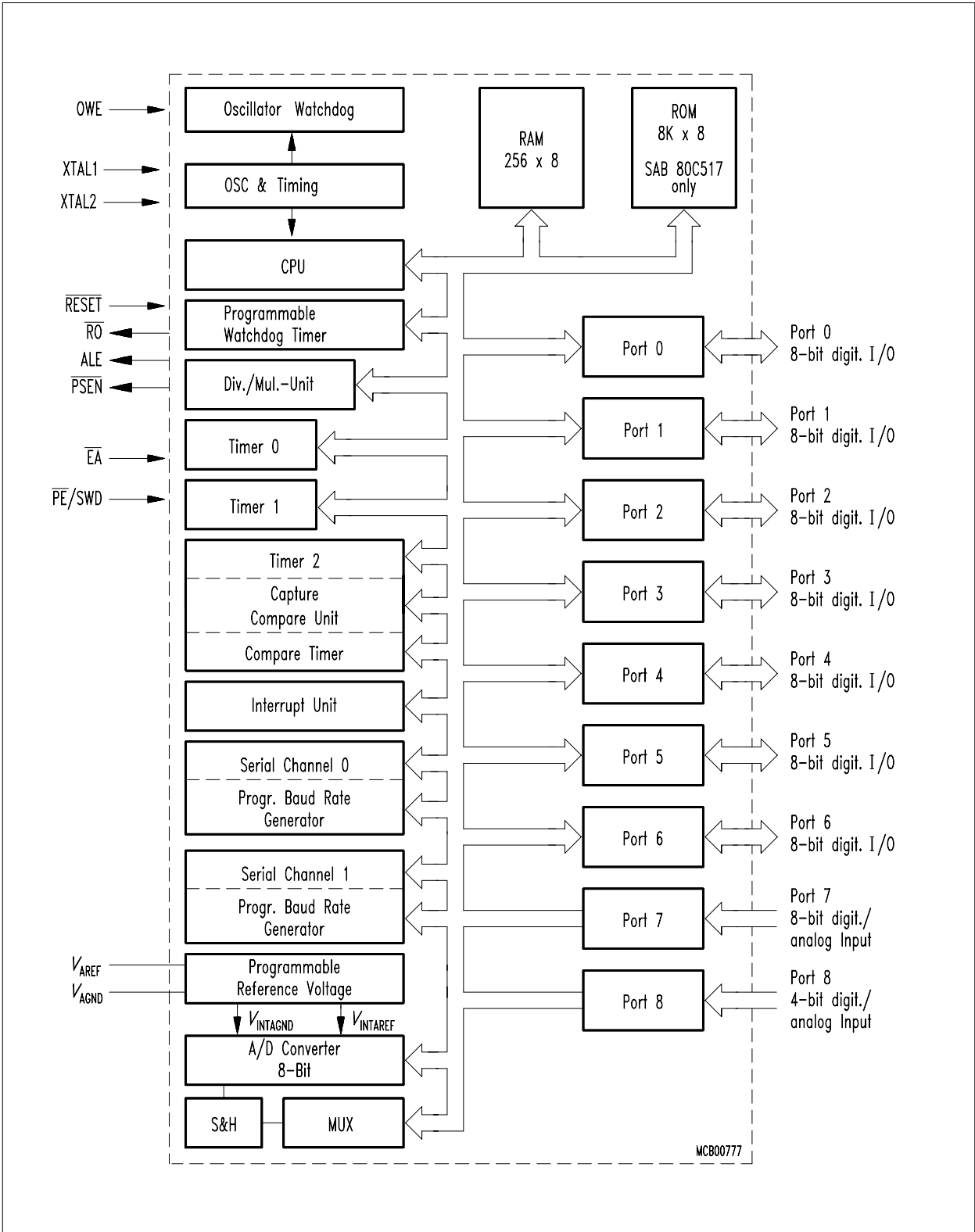

**Figure 1**  
**Block Diagram**



## Functional Description

The SAB 80C517 is based on 8051 architecture. It is a fully compatible member of the Siemens SAB 8051/80C51 microcontroller family being a significantly enhanced SAB 80C515. The SAB 80C517 is therefore 100 % compatible with code written for the SAB 80C515.

## CPU

Having an 8-bit CPU with extensive facilities for bit-handling and binary BCD arithmetics the SAB 80C517 is optimized for control applications. With a 12 MHz crystal, 58% of the instructions execute in 1  $\mu$ s.

Being designed to close the performance gap to the 16-bit microcontroller world, the SAB 80C517's CPU is supported by a powerful 32-/16-bit arithmetic unit and a more flexible addressing of external memory by eight 16-bit datapointers.

## Memory Organisation

According to the SAB 8051 architecture, the SAB 80C517 has separate address spaces for program and data memory. Figure 2 illustrates the mapping of address spaces.

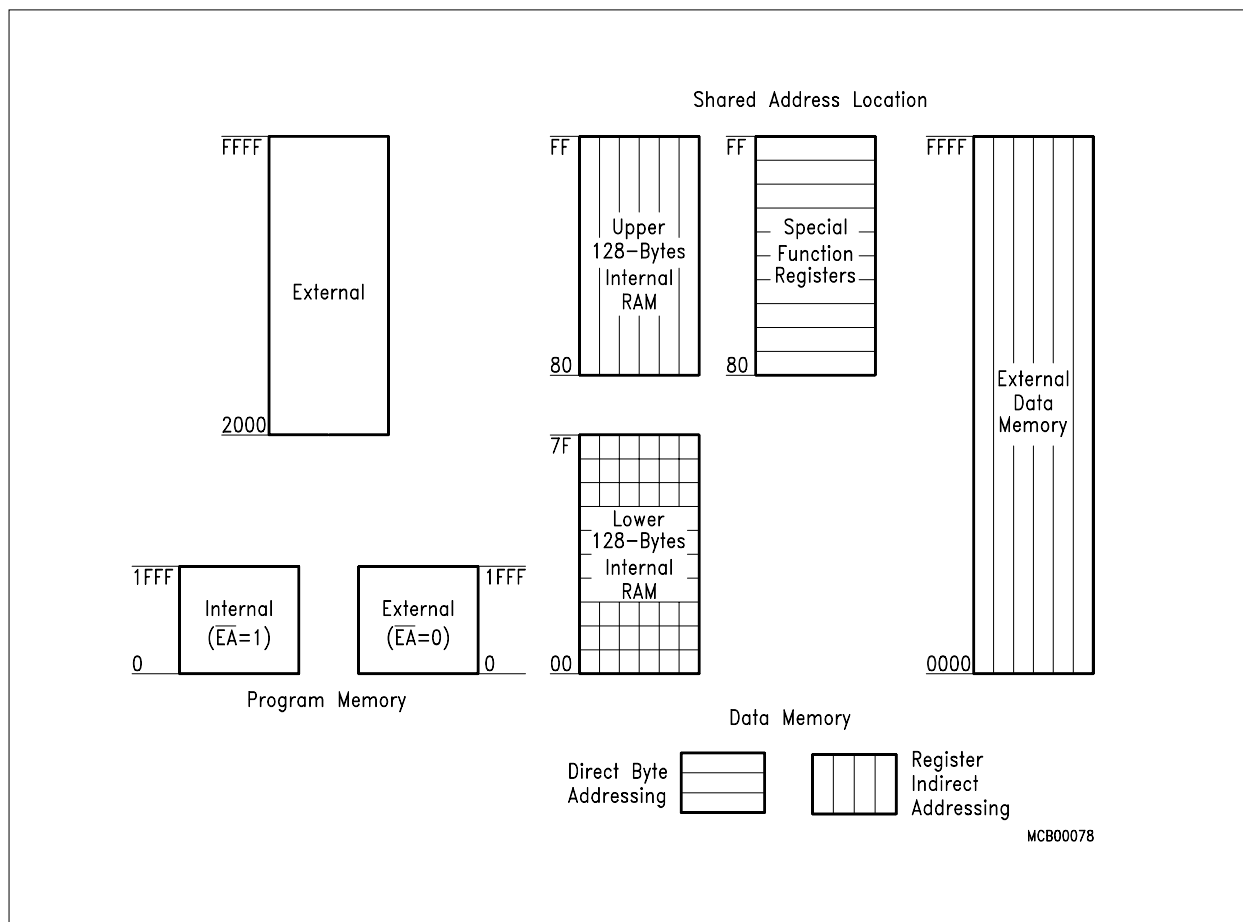

**Figure 2**  
**Memory Mapping**

### Program Memory

The SAB 80C517 has 8 KByte of on-chip ROM, while the SAB 80C537 has no internal ROM. The program memory can externally be expanded up to 64 Kbyte. Pin EA controls whether program fetches below address 2000<sub>H</sub> are done from internal or external memory.

### Data Memory

The data memory space consists of an internal and an external memory space.

### External Data Memory

Up to 64 KByte external data memory can be addressed by instructions that use 8-bit or 16-bit indirect addressing. For 8-bit addressing MOVX instructions utilizing registers R0 and R1 can be used. A 16-bit external memory addressing is supported by eight 16-bit datapointers.

### Multiple Datapointers

As a functional enhancement to standard 8051 controllers, the SAB 80C517 contains eight 16-bit datapointers. The instruction set uses just one of these datapointers at a time. The selection of the actual datapointers is done in special function register DPSEL (data pointer select, addr. 92<sub>H</sub>). **Figure 3** illustrates the addressing mechanism.

### Internal Data Memory

The internal data memory is divided into three physically distinct blocks:

- the lower 128 bytes of RAM including four banks of eight registers each
- the upper 128 byte of RAM
- the 128 byte special function register area.

A mapping of the internal data memory is also shown in **figure 2**. The overlapping address spaces are accessed by different addressing modes. The stack can be located anywhere in the internal data memory.

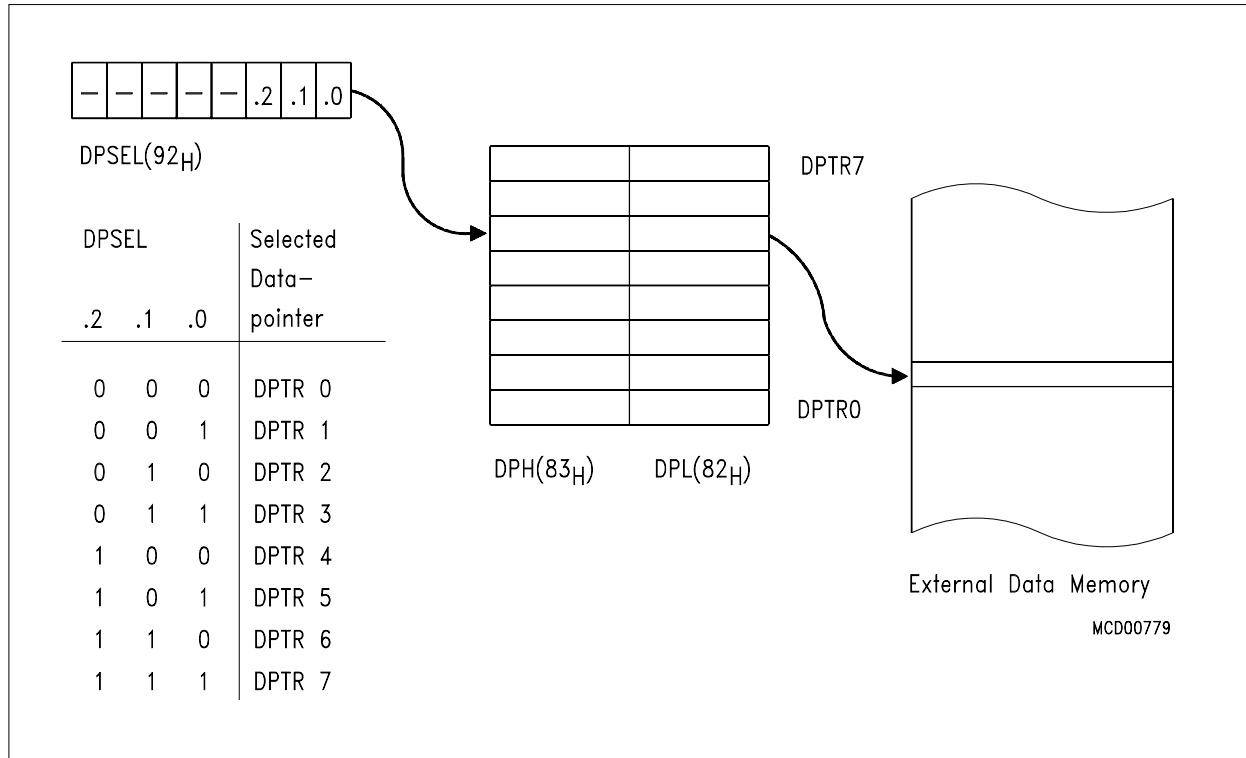

**Figure 3**  
**Addressing of External Data Memory**

## Special Function Registers

All registers, except the program counter and the four general purpose register banks, reside in the special function register area. The 81 special function registers include arithmetic registers, pointers, and registers that provide an interface between the CPU and the on-chip peripherals. There are also 128 directly addressable bits within the SFR area. The special function registers are listed in **table 1**. In this table they are organized in groups which refer to the functional blocks of the SAB 80C517. Block names and symbols are listed in alphabetical order.

**Table 1**  
**Special Function Register**

Address	Register	Name	Register	Contents after Reset
CPU	<b>ACC</b>	<b>Accumulator</b>	<b>0E0<sub>H</sub></b> <sup>1)</sup>	<b>00<sub>H</sub></b>
	<b>B</b>	<b>B-Register</b>	<b>0F0<sub>H</sub></b> <sup>1)</sup>	<b>00<sub>H</sub></b>
	DPH	Data Pointer, High Byte	83 <sub>H</sub>	<b>00<sub>H</sub></b>
	DPL	Data Pointer, Low Byte	82 <sub>H</sub>	<b>00<sub>H</sub></b>
	DPSEL	Data Pointer Select Register	92 <sub>H</sub>	XXXX.X000 <sub>B</sub> <sup>3)</sup>
	<b>PSW</b>	<b>Program Status Word Register</b>	<b>0D0<sub>H</sub></b> <sup>1)</sup>	<b>00<sub>H</sub></b>
	SP	Stack Pointer	81 <sub>H</sub>	07 <sub>H</sub>
A/D- Converter	<b>ADCON0</b>	<b>A/D Converter Control Register 0</b>	<b>0D8<sub>H</sub></b> <sup>1)</sup>	<b>00<sub>H</sub></b>
	ADCON1	A/D Converter Control Register 1	0DC <sub>H</sub>	XXXX.0000 <sub>B</sub> <sup>3)</sup>
	ADDAT	A/D Converter Data Register	0D9 <sub>H</sub>	00 <sub>H</sub>
	DAPR	D/AConverter Program Register	0DA <sub>H</sub>	00 <sub>H</sub>
Interrupt System	<b>IEN0</b>	<b>Interrupt Enable Register 0</b>	<b>0A8<sub>H</sub></b> <sup>1)</sup>	<b>00<sub>H</sub></b>
	CTCON <sup>2)</sup>	Com. Timer Control Register	0E1 <sub>H</sub>	0XXX.0000 <sub>B</sub>
	<b>IEN1</b>	<b>Interrupt Enable Register 1</b>	<b>0B8<sub>H</sub></b> <sup>1)</sup>	<b>00<sub>H</sub></b>
	IEN2	Interrupt Enable Register 2	9A <sub>H</sub>	XXXX.00X0 <sub>B</sub> <sup>3)</sup>
	IP0	Interrupt Priority Register 0	0A9 <sub>H</sub>	00 <sub>H</sub>
	IP1	Interrupt Priority Register 1	0B9 <sub>H</sub>	XX00 0000 <sub>B</sub>
	<b>IRCON</b>	<b>Interrupt Request Control Register</b>	<b>0C0<sub>H</sub></b> <sup>1)</sup>	<b>00<sub>H</sub></b>
	<b>TCON</b> <sup>2)</sup>	<b>Timer Control Register</b>	<b>88<sub>H</sub></b> <sup>1)</sup>	<b>00<sub>H</sub></b>
<b>T2CON</b> <sup>2)</sup>	<b>Timer 2 Control Register</b>	<b>0C8<sub>H</sub></b>	<b>00<sub>H</sub></b>	

1) Bit-addressable special function registers

2) This special function register is listed repeatedly since some bits of it also belong to other functional blocks.

3) X means that the value is indeterminate and the location is reserved

**Table 1**  
**Special Function Register (cont'd)**

Address	Register	Name	Register	Contents after Reset
MUL/DIV Unit	ARCON	Arithmetic Control Register	0EF <sub>H</sub>	0XXX.XXXX <sub>B</sub> <sup>3)</sup>
	MD0	Multiplication/Division Register 0	0E9 <sub>H</sub>	XX <sub>H</sub> <sup>3)</sup>
	MD1	Multiplication/Division Register 1	0EA <sub>H</sub>	XX <sub>H</sub> <sup>3)</sup>
	MD2	Multiplication/Division Register 2	0EB <sub>H</sub>	XX <sub>H</sub> <sup>3)</sup>
	MD3	Multiplication/Division Register 3	0EC <sub>H</sub>	XX <sub>H</sub> <sup>3)</sup>
	MD4	Multiplication/Division Register 4	0ED <sub>H</sub>	XX <sub>H</sub> <sup>3)</sup>
	MD5	Multiplication/Division Register 5	0EE <sub>H</sub>	XX <sub>H</sub> <sup>3)</sup>

- 1) Bit-addressable special function registers
- 2) This special function register is listed repeatedly since some bits of it also belong to other functional blocks.
- 3) X means that the value is indeterminate and the location is reserved

**Table 1**  
**Special Function Register (cont'd)**

Address	Register	Name	Register	Contents after Reset
Compare/ Capture- Unit (CCU)	CCEN	Comp./Capture Enable Reg.	0C1 <sub>H</sub>	00 <sub>H</sub>
	CC4EN	Comp./Capture Enable 4 Reg.	0C9 <sub>H</sub>	X000.0000 <sub>B</sub> <sup>3)</sup>
	CCH1	Comp./Capture Reg. 1, High Byte	0C3 <sub>H</sub>	00 <sub>H</sub>
	CCH2	Comp./Capture Reg. 2, High Byte	0C5 <sub>H</sub>	00 <sub>H</sub>
	CCH3	Comp./Capture Reg. 3, High Byte	0C7 <sub>H</sub>	00 <sub>H</sub>
	CCH4	Comp./Capture Reg. 4, High Byte	0CF <sub>H</sub>	00 <sub>H</sub>
	CCL1	Comp./Capture Reg. 1, Low Byte	0C2 <sub>H</sub>	00 <sub>H</sub>
	CCL2	Comp./Capture Reg. 2, Low Byte	0C4 <sub>H</sub>	00 <sub>H</sub>
	CCL3	Comp./Capture Reg. 3, Low Byte	0C6 <sub>H</sub>	00 <sub>H</sub>
	CCL4	Comp./Capture Reg. 4, Low Byte	0CE <sub>H</sub>	00 <sub>H</sub>
	CMEN	Compare Enable Register	0F6 <sub>H</sub>	00 <sub>H</sub>
	CMH0	Compare Register 0, High Byte	0D3 <sub>H</sub>	00 <sub>H</sub>
	CMH1	Compare Register 1, High Byte	0D5 <sub>H</sub>	00 <sub>H</sub>
	CMH2	Compare Register 2, High Byte	0D7 <sub>H</sub>	00 <sub>H</sub>
	CMH3	Compare Register 3, High Byte	0E3 <sub>H</sub>	00 <sub>H</sub>
	CMH4	Compare Register 4, High Byte	0E5 <sub>H</sub>	00 <sub>H</sub>
	CMH5	Compare Register 5, High Byte	0E7 <sub>H</sub>	00 <sub>H</sub>
	CMH6	Compare Register 6, High Byte	0F3 <sub>H</sub>	00 <sub>H</sub>
	CMH7	Compare Register 7, High Byte	0F5 <sub>H</sub>	00 <sub>H</sub>
	CML0	Compare Register 0, Low Byte	0D2 <sub>H</sub>	00 <sub>H</sub>
	CML1	Compare Register 1, Low Byte	0D4 <sub>H</sub>	00 <sub>H</sub>
	CML2	Compare Register 2, Low Byte	0D6 <sub>H</sub>	00 <sub>H</sub>
	CML3	Compare Register 3, Low Byte	0E2 <sub>H</sub>	00 <sub>H</sub>
	CML4	Compare Register 4, Low Byte	0E4 <sub>H</sub>	00 <sub>H</sub>
	CML5	Compare Register 5, Low Byte	0E6 <sub>H</sub>	00 <sub>H</sub>
	CML6	Compare Register 6, Low Byte	0F2 <sub>H</sub>	00 <sub>H</sub>
	CML7	Compare Register 7, Low Byte	0F4 <sub>H</sub>	00 <sub>H</sub>
	CMSEL	Compare Input Select	0F7 <sub>H</sub>	00 <sub>H</sub>
	CRCH	Com./Rel./Capt. Reg. High Byte	0CB <sub>H</sub>	00 <sub>H</sub>
	CRCL	Com./Rel./Capt. Reg. Low Byte	0CA <sub>H</sub>	00 <sub>H</sub>
	CTCON	Com. Timer Control Reg.	0E1 <sub>H</sub>	0XXX.0000 <sub>B</sub> <sup>3)</sup>
	CTRELH	Com. Timer Rel. Reg., High Byte	0DF <sub>H</sub>	00 <sub>H</sub>
	CTRELL	Com. Timer Rel. Reg., Low Byte	0DE <sub>H</sub>	00 <sub>H</sub>
TH2	Timer 2, High Byte	0CD <sub>H</sub>	00 <sub>H</sub>	
TL2	Timer 2, Low Byte	0CC <sub>H</sub>	00 <sub>H</sub>	
	<b>T2CON</b>	<b>Timer 2 Control Register</b>	<b>0C8<sub>H</sub><sup>1)</sup></b>	<b>00<sub>H</sub></b>

<sup>1)</sup> Bit-addressable special function registers

<sup>2)</sup> This special function register is listed repeatedly since some bits of it also belong to other functional blocks.

<sup>3)</sup> X means that the value is indeterminate and the location is reserved

**Table 1**  
**Special Function Register (cont'd)**

Address	Register	Name	Register	Contents after Reset
Ports	<b>P0</b>	<b>Port 0</b>	<b>80<sub>H</sub></b> <sup>1)</sup>	<b>FF<sub>H</sub></b>
	<b>P1</b>	<b>Port 1</b>	<b>90<sub>H</sub></b> <sup>1)</sup>	<b>FF<sub>H</sub></b>
	<b>P2</b>	<b>Port 2</b>	<b>0A0<sub>H</sub></b> <sup>1)</sup>	<b>FF<sub>H</sub></b>
	<b>P3</b>	<b>Port 3</b>	<b>0B0<sub>H</sub></b> <sup>1)</sup>	<b>FF<sub>H</sub></b>
	<b>P4</b>	<b>Port 4</b>	<b>0E8<sub>H</sub></b> <sup>1)</sup>	<b>FF<sub>H</sub></b>
	<b>P5</b>	<b>Port 5</b>	<b>0F8<sub>H</sub></b> <sup>1)</sup>	<b>FF<sub>H</sub></b>
	P6	Port 6,	0FA <sub>H</sub>	FF <sub>H</sub>
	P7	Port 7, Analog/Digital Input	0DB <sub>H</sub>	XX <sub>H</sub> <sup>3)</sup>
	P8	Port 8, Analog/Digital Input, 4-bit	0DD <sub>H</sub>	XX <sub>H</sub> <sup>3)</sup>
Pow.Sav. Modes	PCON	Power Control Register	87 <sub>H</sub>	00 <sub>H</sub>
Serial Channels	<b>ADCON0</b> <sup>2)</sup>	<b>A/D Converter Control Reg.</b>	<b>0D8<sub>H</sub></b> <sup>1)</sup>	<b>00<sub>H</sub></b>
	PCON <sup>2)</sup>	Power Control Register	87 <sub>H</sub>	00 <sub>H</sub>
	S0BUF	Serial Channel 0 Buffer Reg.	99 <sub>H</sub>	XX <sub>H</sub> <sup>3)</sup>
	<b>S0CON</b>	<b>Serial Channel 0 Control Reg.</b>	<b>98<sub>H</sub></b> <sup>1)</sup>	<b>00<sub>H</sub></b>
	S0RELL <sup>4)</sup>	Serial Channel 0, Reload Reg., low byte	0AA <sub>H</sub>	0D9 <sub>H</sub>
	S0RELH <sup>4)</sup>	Serial Channel 0, Reload Reg., high byte	0BA <sub>H</sub>	XXXX.XX11 <sub>B</sub> <sup>3)</sup>
	S1BUF	Serial Channel 1 Buffer Reg.,	9C <sub>H</sub>	0XX <sub>H</sub> <sup>3)</sup>
	S1CON	Serial Channel 1 Control Reg.	9B <sub>H</sub>	0X00.000 <sub>B</sub> <sup>3)</sup>
S1REL	Serial Channel 1 Reload Reg., low byte	9D <sub>H</sub>	00 <sub>H</sub>	
S1RELH <sup>4)</sup>	Serial Channel 1, Reload Reg., high byte	0BB <sub>H</sub>	XXXX.XX11 <sub>B</sub> <sup>3)</sup>	
Timer 0/ Timer 1	<b>TCON</b>	<b>Timer Control Register</b>	<b>88<sub>H</sub></b> <sup>1)</sup>	<b>00<sub>H</sub></b>
	TH0	Timer 0, High Byte	8C <sub>H</sub>	00 <sub>H</sub>
	TH1	Timer 1, High Byte	8D <sub>H</sub>	00 <sub>H</sub>
	TL0	Timer 0, Low Byte	8A <sub>H</sub>	00 <sub>H</sub>
	TL1	Timer 1, Low Byte	8B <sub>H</sub>	00 <sub>H</sub>
	TMOD	Timer Mode Register	89 <sub>H</sub>	00 <sub>H</sub>
Watchdog	<b>IEN0</b> <sup>2)</sup>	<b>Interrupt Enable Register 0</b>	<b>0A8<sub>H</sub></b> <sup>1)</sup>	<b>00<sub>H</sub></b>
	<b>IEN1</b> <sup>2)</sup>	<b>Interrupt Enable Register 1</b>	<b>0B8<sub>H</sub></b> <sup>1)</sup>	<b>00<sub>H</sub></b>
	IP0 <sup>2)</sup>	Interrupt Priority Register 0	0A9 <sub>H</sub>	00 <sub>H</sub>
	IP1 <sup>2)</sup>	Interrupt Priority Register 1	0B9 <sub>H</sub>	XX00.0000 <sub>B</sub> <sup>3)</sup>
	WDTREL	Watchdog Timer Reload Reg.	86 <sub>H</sub>	00 <sub>H</sub>

1) Bit-addressable special function registers.

2) This special function register is listed repeatedly since some bits of it also belong to other functional blocks.

3) X means that the value is indeterminate and the location is reserved.

4) These registers are available in the CA step and later steps.

## A/D Converter

The SAB 80C517 contains an 8-bit A/D Converter with 12 multiplexed input channels which uses the successive approximation method. It takes 7 machine cycles to sample an analog signal (during this sample time the input signal should be held constant); the total conversion time (including sample time) is 13 machine cycles (13  $\mu$ s at 12 MHz oscillator frequency). Conversion can be programmed to be single or continuous; at the end of a conversion an interrupt can be generated.

A unique feature is the capability of internal reference voltage programming. The internal reference voltages  $V_{IntAREF}$  and  $V_{IntAGND}$  for the A/D converter are both programmable to one of 16 steps with respect to the external reference voltages. This feature permits a conversion with a smaller internal reference voltage range to gain a higher resolution. In addition, the internal reference voltages can easily be adapted by software to the desired analog input voltage range (see **table 2**).

**Table 2**  
**Adjustable Internal Reference Voltages**

Step	DAPR (.3-.0) DAPR (.7-.4)	$V_{IntAGND}$	$V_{IntAREF}$
0	0000	0.0	5.0
1	0001	0.3125	–
2	0010	0.625	–
3	0011	0.9375	–
4	0100	1.25	1.25
5	0101	1.5625	1.5625
6	0110	1.875	1.875
7	0111	2.1875	2.1875
8	1000	2.5	2.5
9	1001	2.8125	2.8125
10	1010	3.125	3.125
11	1011	3.4375	3.4375
12	1100	3.75	3.75
13	1101	–	4.0625
14	1110	–	4.375
15	1111	–	4.68754



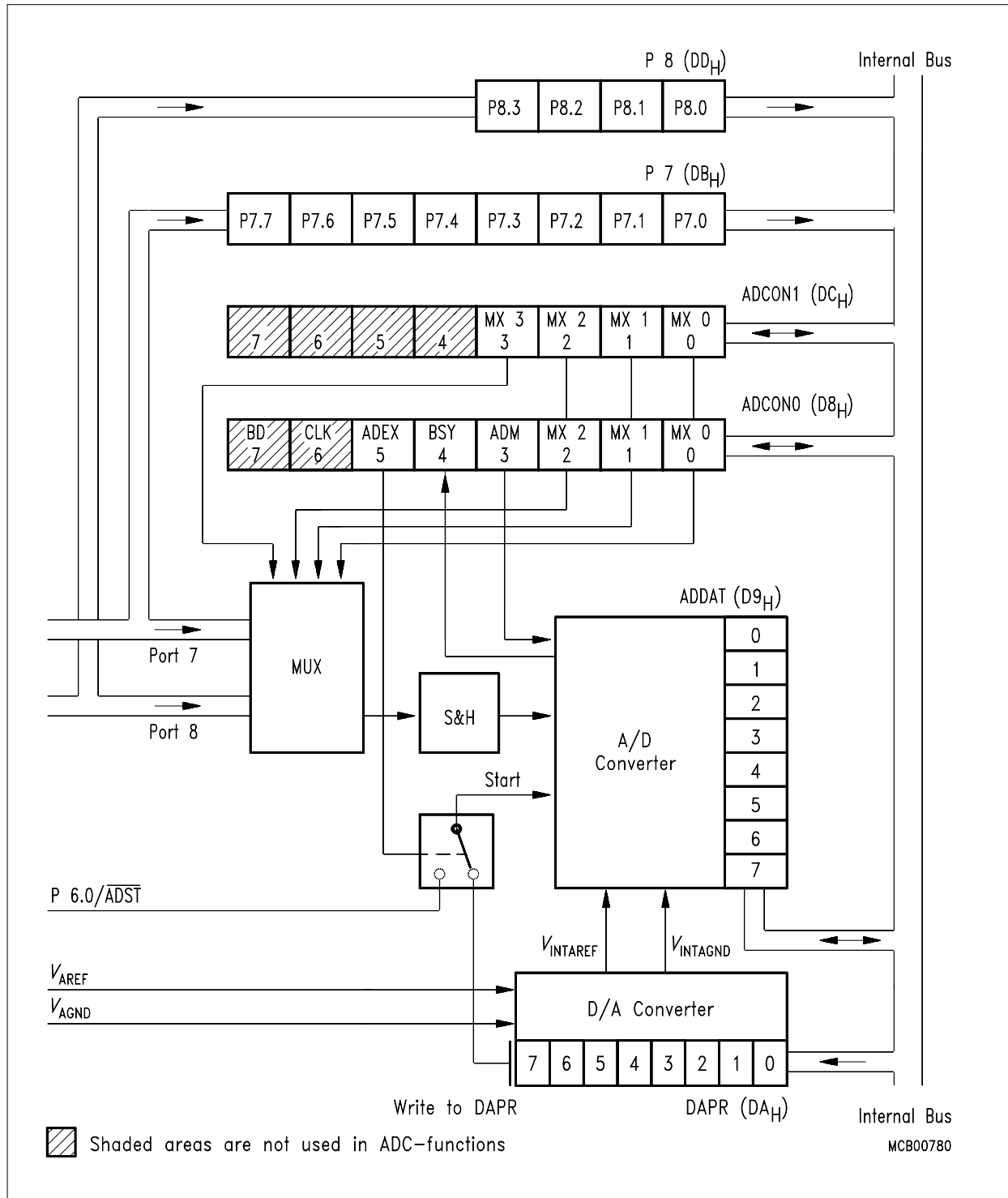

**Figure 4**  
**Block Diagram A/D Converter**

**Compare/Capture Unit (CCU)**

The compare capture unit is a complex timer/register array for applications that require high speed I/O, pulse width modulation and more timer/counter capabilities. The CCU contains

- one 16-bit timer/counter (**timer 2**) with 2-bit prescaler, reload capability and a max. clock frequency of  $f_{OSC}/12$  (1 MHz with a 12 MHz crystal).
- one 16-bit timer (**compare timer**) with 8-bit prescaler, reload capability and a max. clock frequency of  $f_{OSC}/2$  (6 MHz with a 12 MHz crystal).
- thirteen 16-bit compare registers.
- five of which can be used as 16-bit capture registers.
- up to 21 output lines controlled by the CCU.
- seven interrupts which can be generated by CCU-events.

**Figure 5** shows a block diagram of the CCU. Eight compare registers (CM0 to CM7) can individually be assigned to either timer 2 or the compare timer. Diagrams of the two timers are shown in **figures 6 and 7**. The four compare/capture registers and the compare/reload/capture register are always connected to timer 2. Dependent on the register type and the assigned timer two compare modes can be selected. **Table 3** illustrates possible combinations and the corresponding output lines.

**Table 3  
CCU Configuration**

Assigned Timer	Compare Register	Compare Output at	Possible Modes
Timer 2	CRCH/CRCL	P1.0/ $\overline{\text{INT3}}$ /CC0	Comp. mode 0, 1 + Reload
	CC1H/CC1L	P1.0/INT4/CC1	Comp. mode 0, 1
	CC2H/CC2L	P1.0/INT5/CC2	Comp. mode 0, 1
	CC3H/CC3L	P1.0/INT6/CC3	Comp. mode 0, 1
	CC4H/CC4L	P1.0/ $\overline{\text{INT2}}$ /CC4	Comp. mode 0, 1
	CC4H/CC4L	P5.0/CCM0	Comp. mode 1
	⋮	⋮	⋮
	CC4H/CC4L	P5.7/CCM7	Comp. mode 1
	CM0H/CM0L	P4.0/CM0	Comp. mode 1
	⋮	⋮	⋮
CM7H/CM7L	P4.7/CM7	Comp. mode 1	
Compare timer	CM0H/CM0L	P4.0/CM0	Comp. mode 0 (with add. latches)
	⋮	⋮	⋮
	CM7H/CM7L	P4.7/CM7	Comp. mode 0 (with shadow latches)

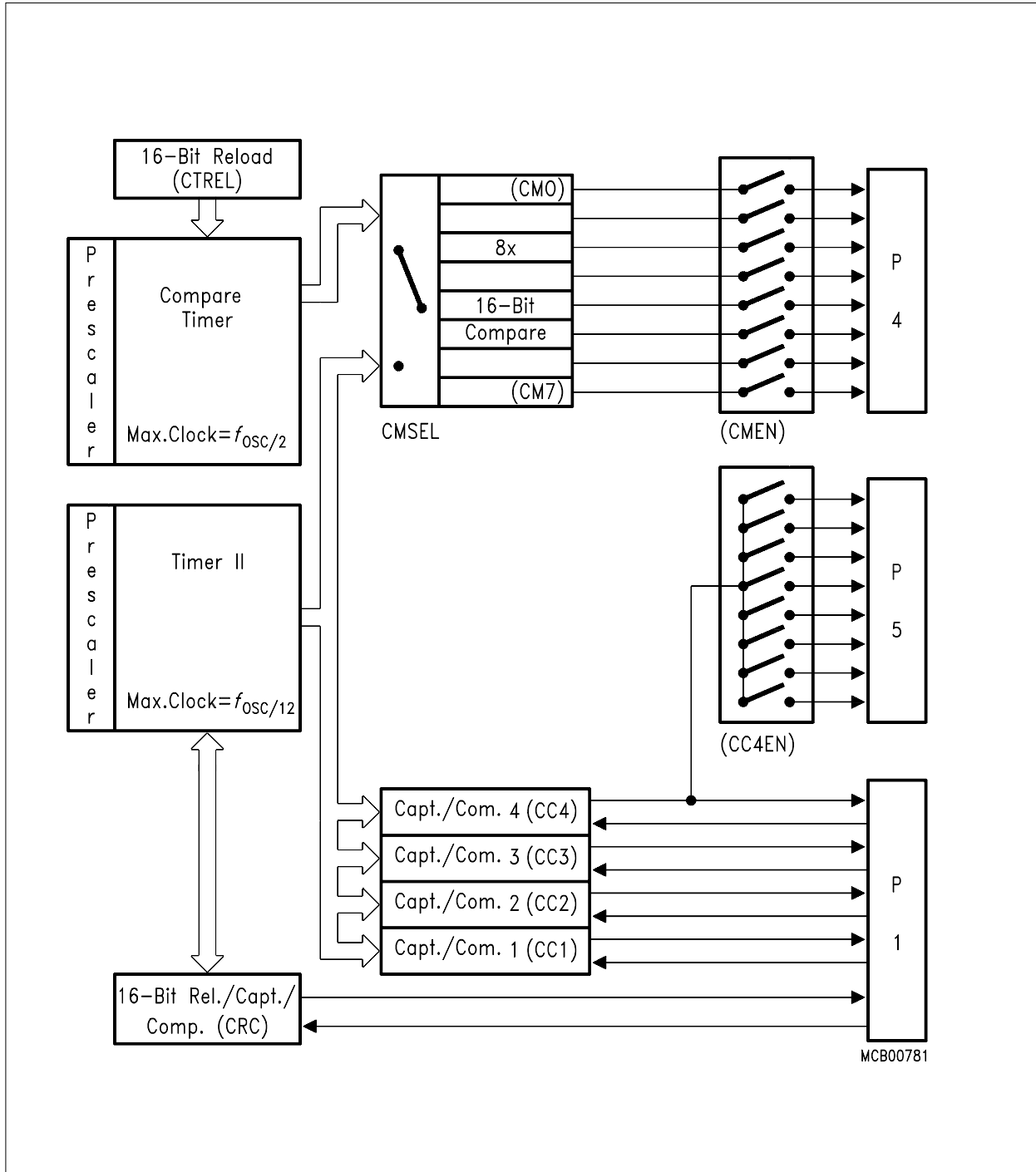

**Figure 5**  
**Block Diagram of the Compare/Capture Unit**

## Compare

In the compare mode, the 16-bit values stored in the dedicated compare registers are compared to the contents of the timer 2 register or the compare timer register. If the count value in the timer registers matches one of the stored values, an appropriate output signal is generated and an interrupt is requested. Two compare modes are provided:

Mode 0: Upon a match the output signal changes from low to high. It goes back to low level when the timer overflows.

Mode 1: The transition of the output signal can be determined by software. A timer overflow signal doesn't affect the compare-output.

Compare registers CM0 to CM7 use additional compare latches when operated in mode 0. **Figure 8** shows the function of these latches. The latches are implemented to prevent from loss of compare matches which may occur when loading of the compare values is not correlated with the timer count. The compare latches are automatically loaded from the compare registers at every timer overflow.

## Capture

This feature permits saving of the actual timer/counter contents into a selected register upon an external event or a software write operation. Two modes are provided to latch the current 16-bit value of timer 2 registers into a dedicated capture register.

Mode 0: Capture is performed in response to a transition at the corresponding port pins CC0 to CC3.

Mode 1: Write operation into the low-order byte of the dedicated capture register causes the timer 2 contents to be latched into this register.

## Reload of Timer 2

A 16-bit reload can be performed with the 16-bit CRC register, which is a concatenation of the 8-bit registers CRCL and CRCH. There are two modes from which to select:

Mode 0: Reload is caused by a timer overflow (auto-reload).

Mode 1: Reload is caused in response to a negative transition at pin T2EX (P1.5), which also can request an interrupt.

## Timer/Counters 0 and 1

These timer/counters are fully compatible with timer/counter 0 or 1 of the SAB 8051 and can operate in four modes:

Mode 0: 8-bit timer/counter with 32:1 prescaler

Mode 1: 16-bit timer/counter

Mode 2: 8-bit timer/counter with 8-bit auto reload

Mode 3: Timer/counter 0 is configured as one 8-bit timer; timer/counter 1 in this mode holds its count.

External inputs  $\overline{\text{INT0}}$  and  $\overline{\text{INT1}}$  can be programmed to function as a gate for timer/counters 0 and 1 to facilitate pulse width measurements.

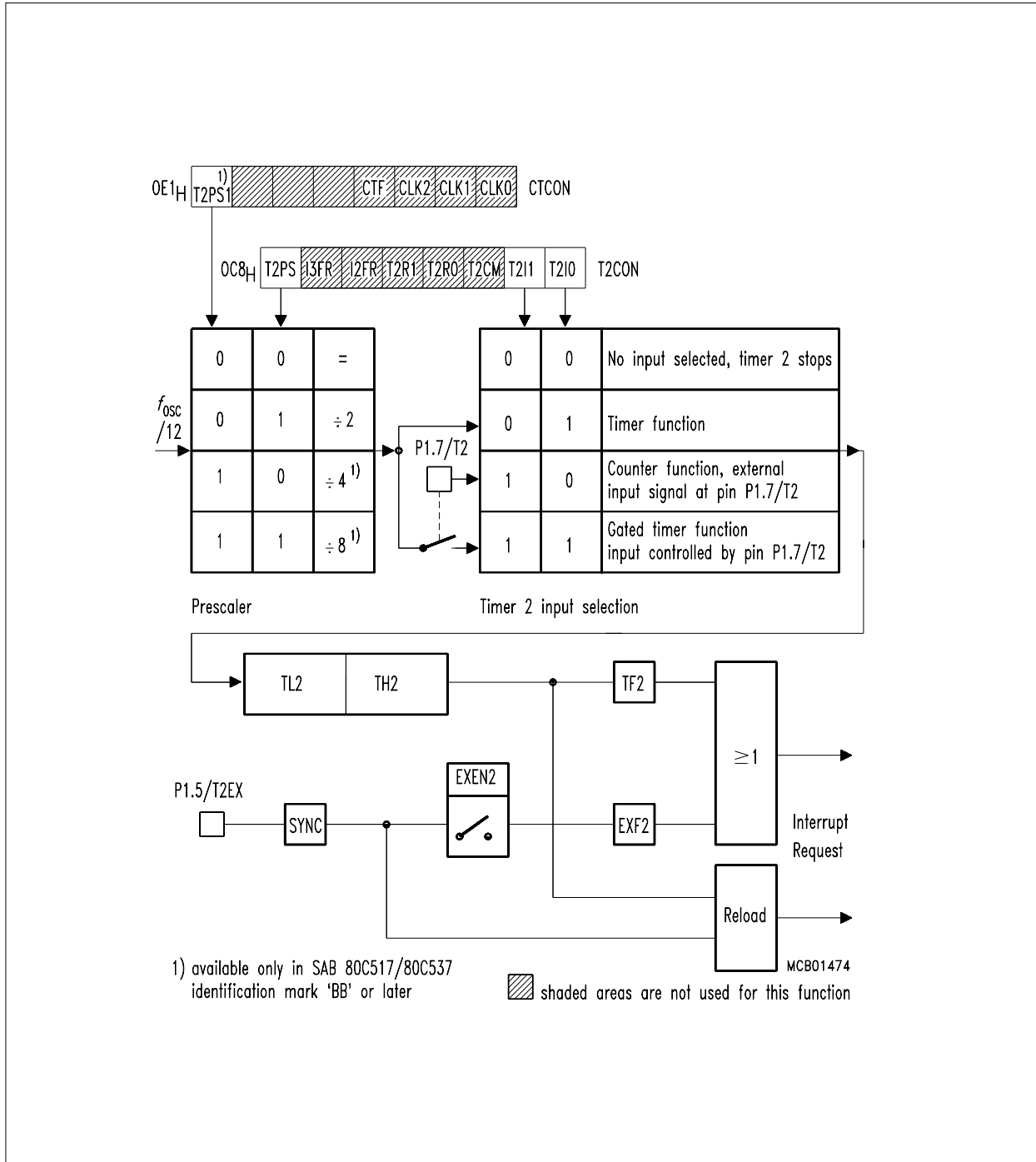

**Figure 6**  
**Block Diagram of Timer 2**

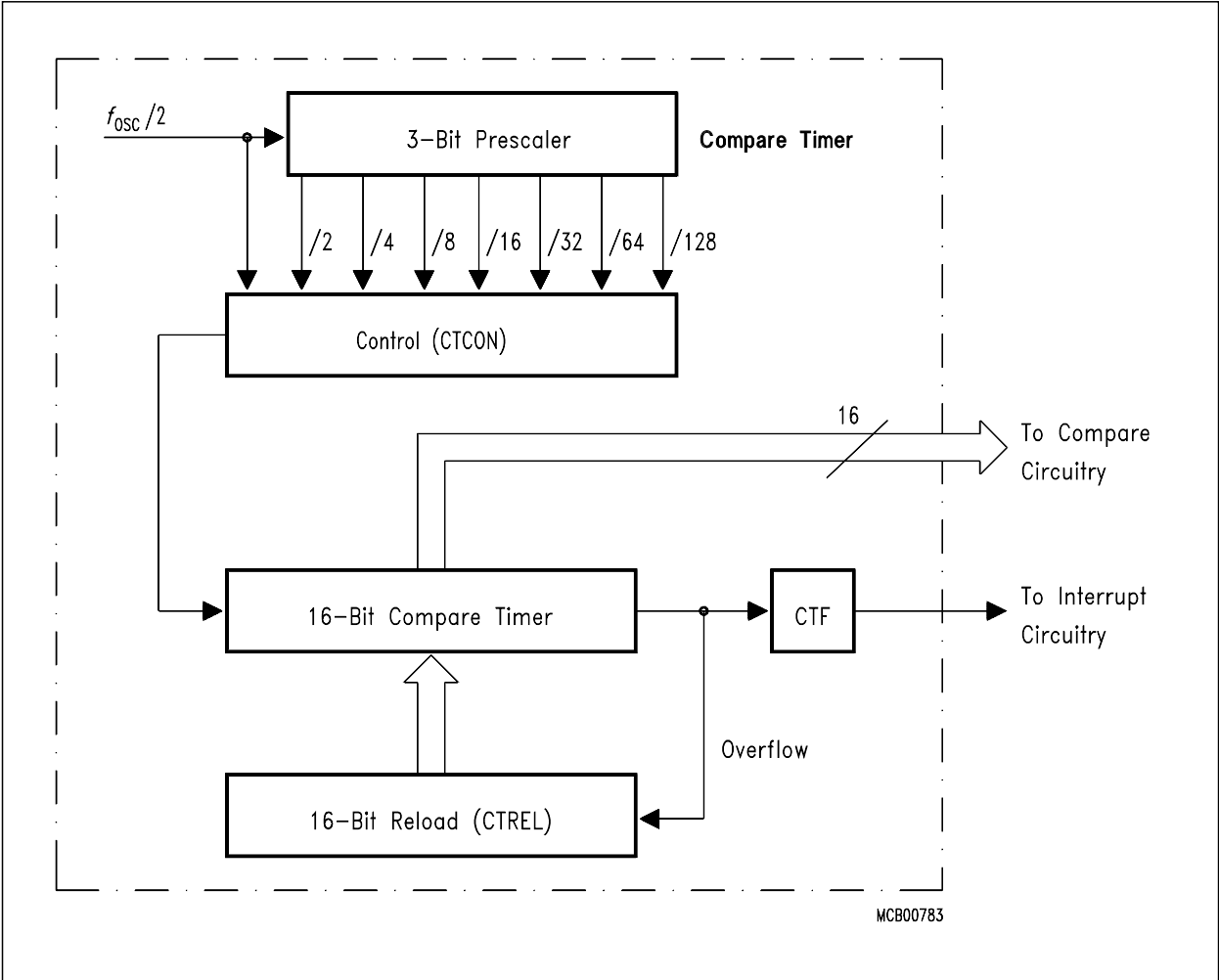
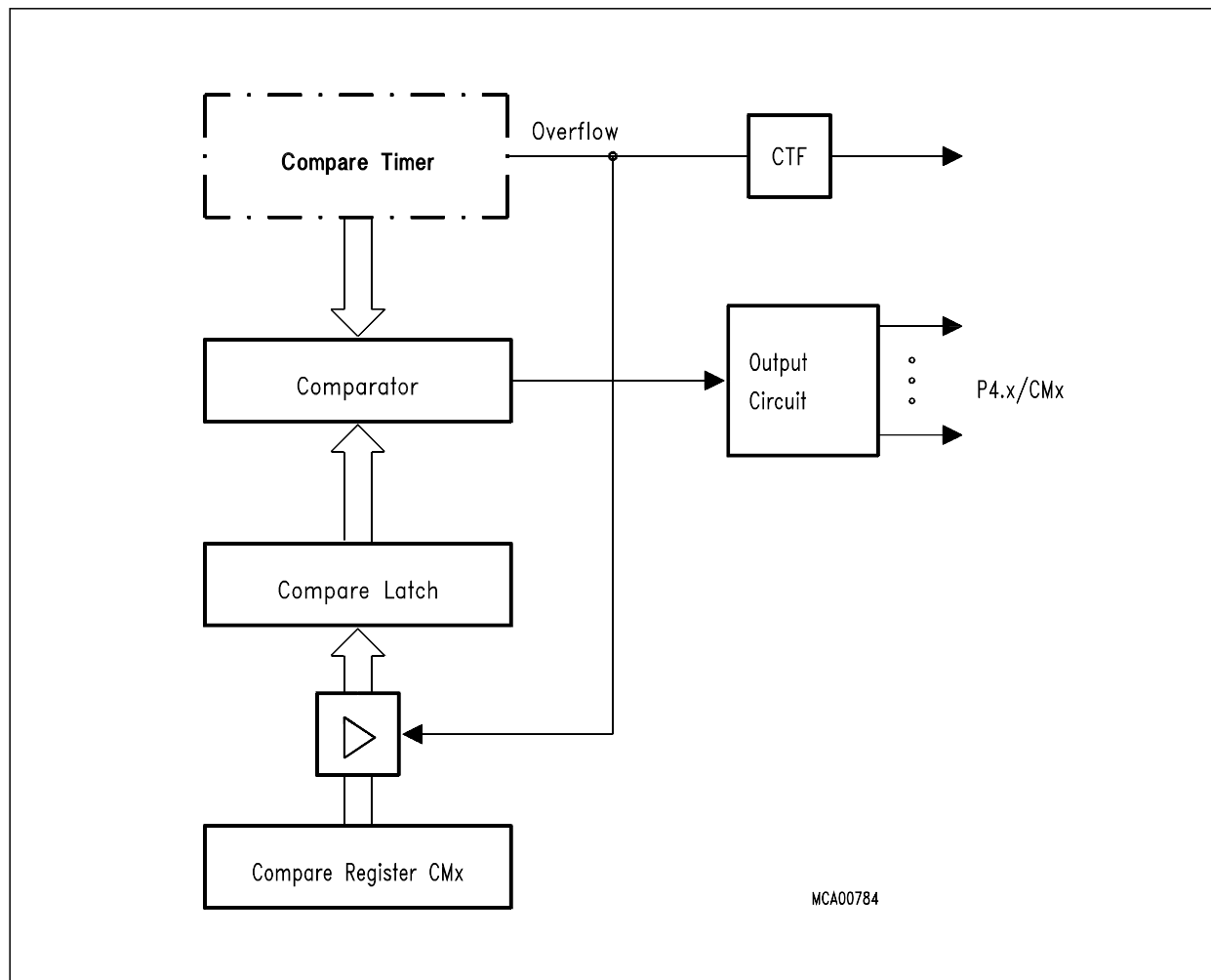

Figure 7  
Block Diagram of the Compare Timer



**Figure 8**  
**Compare-Mode 0 with Registers CM0 to CM7**

**Interrupt Structure**

The SAB 80C517 has 14 interrupt vectors with the following vector addresses and request flags.

**Table 4  
Interrupt Sources and Vectors**

Source (Request Flags)	Vector Address	Vector
IE0	0003 <sub>H</sub>	External interrupt 0
TF0	000B <sub>H</sub>	Timer 0 overflow
IE1	0013 <sub>H</sub>	External interrupt 1
TF1	001B <sub>H</sub>	Timer 1 overflow
RI0/TI0	0023 <sub>H</sub>	Serial channel 0
TF2 + EXF2	002B <sub>H</sub>	Timer 2 overflow/ext. reload
IADC	0043 <sub>H</sub>	A/D converter
IEX2	004B <sub>H</sub>	External interrupt 2
IEX3	0053 <sub>H</sub>	External interrupt 3
IEX4	005B <sub>H</sub>	External interrupt 4
IEX5	0063 <sub>H</sub>	External interrupt 5
IEX6	006B <sub>H</sub>	External interrupt 6
RI1/TI1	0083 <sub>H</sub>	Serial channel 1
CTF	009B <sub>H</sub>	Compare timer overflow

Each interrupt vector can be individually enabled/disabled. The response time to an interrupt request is more than 3 machine cycles and less than 9 machine cycles.

External interrupts 0 and 1 can be activated by a low-level or a negative transition (selectable) at their corresponding input pin, external interrupts 2 and 3 can be programmed for triggering on a negative or a positive transition. The external interrupts 2 to 6 are combined with the corresponding alternate functions compare (output) and capture (input) on port 1.

For programming of the priority levels the interrupt vectors are combined to pairs or triples. Each pair or triple can be programmed individually to one of four priority levels by setting or clearing one bit in special function register IP0 and one in IP1. **Figure 9** shows the interrupt request sources, the enabling and the priority level structure.



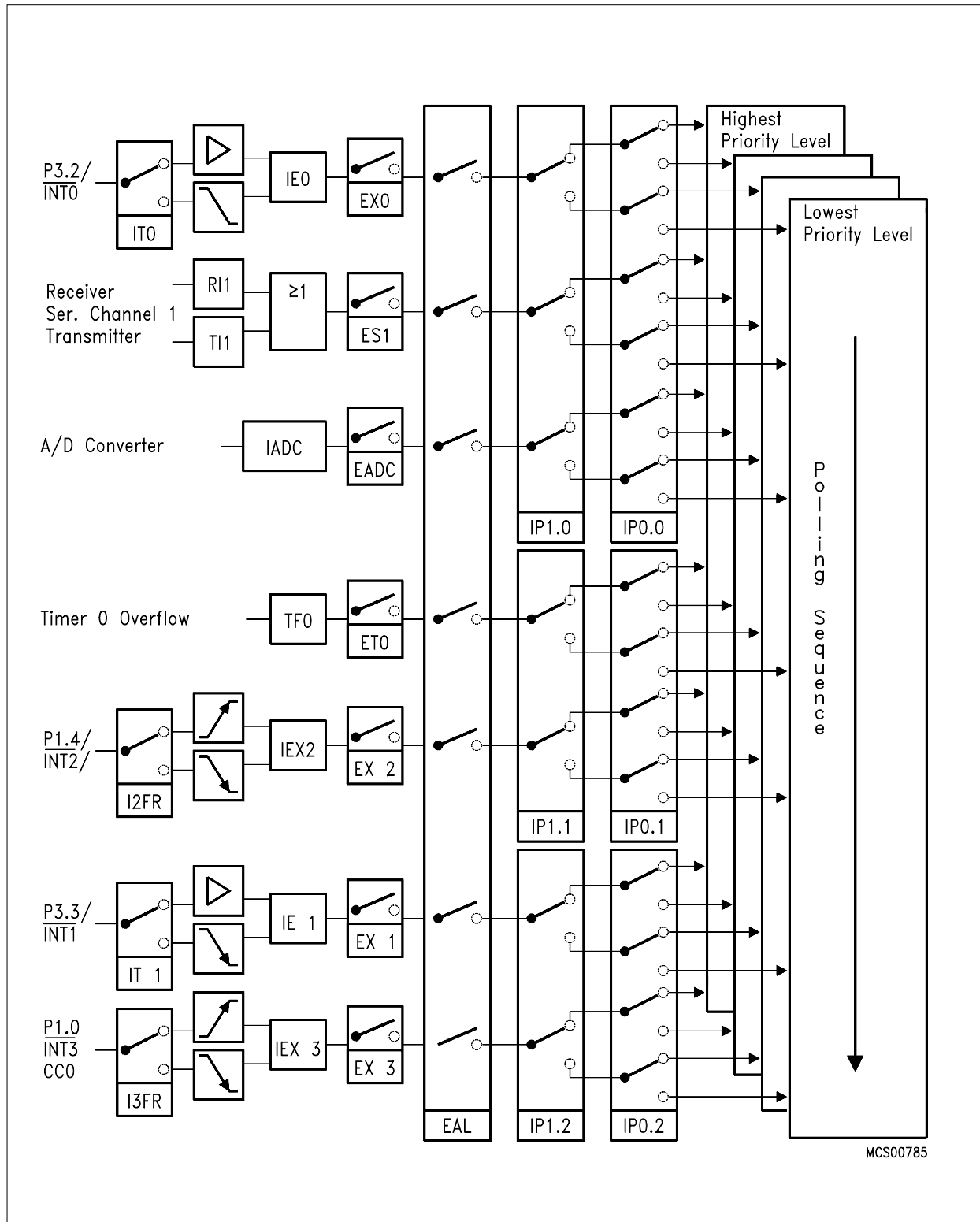

**Figure 9**  
**Interrupt Structure**

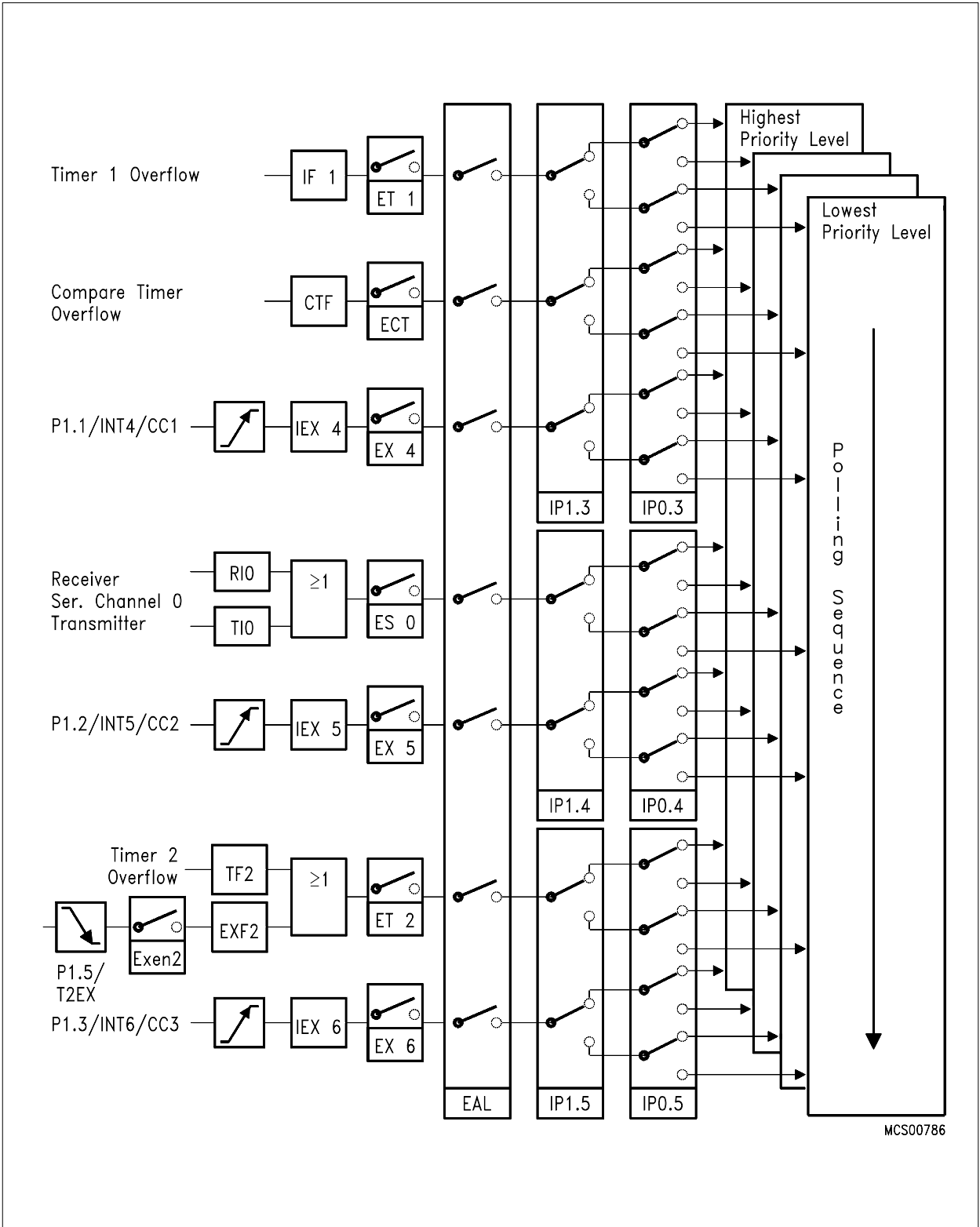

Figure 9 (cont'd)  
Interrupt Structure

**Multiplication/Division Unit**

This on-chip arithmetic unit provides fast 32-bit division, 16-bit multiplication as well as shift and normalize features. All operations are integer operations.

Operation	Result	Remainder	Execution Time
32-bit/16-bit 16-bit/16-bit	32-bit 16-bit	16-bit 16-bit	$6 t_{cy}^{1)}$ $4 t_{cy}$
16-bit * 16-bit	32-bit	–	$4 t_{cy}$
32-bit normalize	–	–	$6 t_{cy}^{2)}$
32-bit shift left/right	–	–	$6 t_{cy}^{2)}$

1)  $1 t_{cy} = 1 \mu s$  @ 12 MHz oscillator frequency.

2) The maximal shift speed is 6 shifts/cycle.

The MDU consists of six registers used for operands and results and one control register. Operation of the MDU can be divided in three phases:

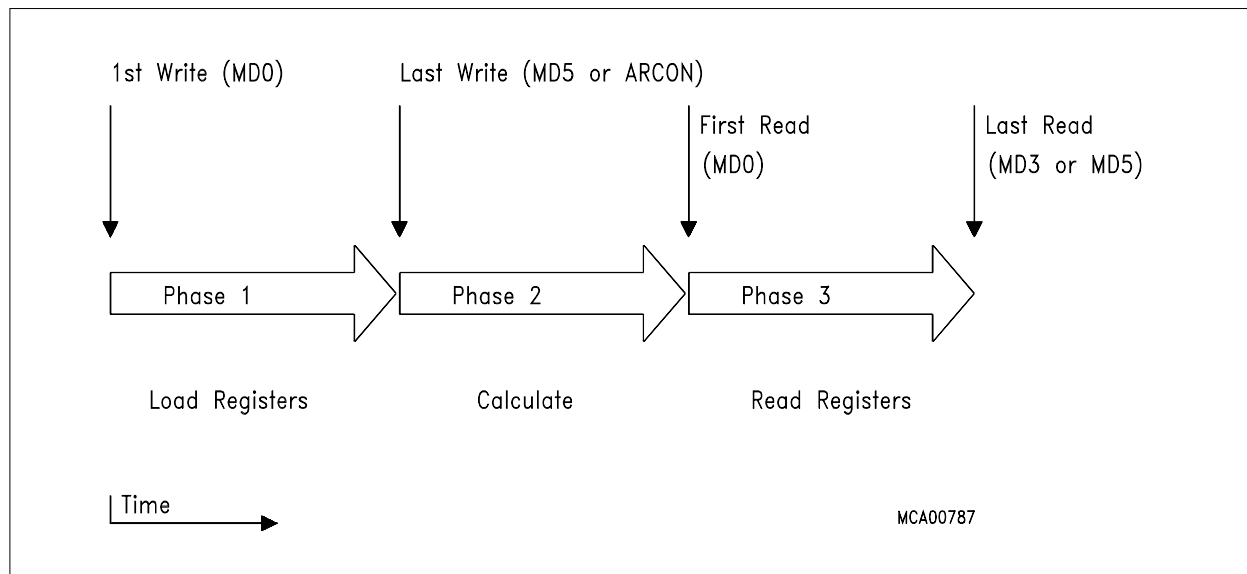

**Figure 10**  
**Operation of the MDU**

To start an operation, register MD0 to MD5 (or ARCON) must be written to in a certain sequence according to table 5 or 6. The order the registers are accessed determines the type of the operation. A shift operation is started by a final write operation to register ARCON (**see also the register description**).

**Table 5  
Programming the MDU for Multiplication and Division**

Operation	32-Bit/16-Bit		16-Bit/16-Bit		16-Bit * 16-Bit	
First Write	MD0	D'endL	MD0	D'endL	MD0	M'andL
	MD1	D'end	MD1	D'end	MD4	M'orL
	MD2	D'end		D'end		
	MD3	D'endH	MD4	D'endH	MD1	M'andH
	MD4	D'orL		D'orL		
Last Write	MD5	D'orH	MD5	D'orH	MD5	M'orH
First Read	MD0	QuoL	MD0	QuoL	MD0	PrL
	MD1	Quo	MD1	QuoH	MD1	
	MD2	Quo				
	MD3	QuoH	MD4	RemL	MD2	
	MD4	RemL				
Last Read	MD5	RemH	MD5	RemH	MD3	PrH

**Table 6  
Shift Operation with the CCU**

Operation	Normalize, Shift Left, Shift Right	
First Write	MD0	least significant byte
	MD1	
	MD2	
Last Write	MD3	most significant byte start of conversion
	ARCON	
First Read	MD0	least significant byte
	MD1	
	MD2	
Last Read	MD3	most significant byte

**Abbreviations**

- D'end : Dividend, 1st operand of division
- D'or : Divisor, 2nd operand of division
- M'and : Multiplicand, 1st operand of multiplication
- M'or : Multiplier, 2nd operand of multiplication
- Pr : Product, result of multiplication
- Rem : Remainder
- Quo : Quotient, result of division
- ...L : means, that this byte is the least significant of the 16-bit or 32-bit operand
- ...H : means, that this byte is the most significant of the 16-bit or 32-bit operand

## I/O Ports

The SAB 80C517 has seven 8-bit I/O ports and two input ports (8-bit and 4-bit wide).

Port 0 is an open-drain bidirectional I/O port, while ports 1 to 6 are quasi-bidirectional I/O ports with internal pull-up resistors. That means, when configured as inputs, ports 1 to 6 will be pulled high and will source current when externally pulled low. Port 0 will float when configured as input.

Port 0 and port 2 can be used to expand the program and data memory externally. During an access to external memory, port 0 emits the low-order address byte and reads/writes the data byte, while port 2 emits the high-order address byte. In this function, port 0 is not an open-drain port, but uses a strong internal pullup FET. Port 1, 3, 4, 5 and port 6 provide several alternate functions. **Please see the "Pin Description" for details.**

Port pins show the information written to the port latches, when used as general purpose port. When an alternate function is used, the port pin is controlled by the respective peripheral unit. Therefore the port latch must contain a "one" for that function to operate. The same applies when the port pins are used as inputs. Ports 1, 3, 4 and 5 are bit-addressable.

The SAB 80C517 has two dual-purpose input ports. The twelve port lines at port 7 and port 8 can be used as analog inputs for the A/D converter. If input voltages at P7 and P8 meet the specified digital input levels ( $V_{IL}$  and  $V_{IH}$ ) the port can also be used as digital input port.

### Power Saving Modes

The SAB 80C517 provides – due to Siemens ACMOS technology – three modes in which power consumption can be significantly reduced.

- The **Slow Down Mode**

The controller keeps up the full operating functionality, but is driven with the eighth part of its normal operating frequency. Slowing down the frequency greatly reduces power consumption.

- The **Idle Mode**

The CPU is gated off from the oscillator, but all peripherals are still supplied by the clock and able to work.

- The **Power Down Mode**

Operation of the SAB 80C517 is stopped, the oscillator is turned off. This mode is used to save the contents of the internal RAM with a very low standby current.

All of these modes are entered by software. Special function register PCON (power control register, address is 87<sub>H</sub>) is used to select one of these modes.

### Hardware Enable for Power Saving Modes

A dedicated Pin ( $\overline{\text{PE}}/\text{SWD}$ ) of the SAB 80C517 allows to block the power saving modes. Since this pin is mostly used in noise-critical application it is combined with an automatic start of the Watchdog Timer (see there for further description).

$\overline{\text{PE}}/\text{SWD} = V_{\text{IH}}$  (logic high level): Using of the power saving modes is not possible. The instruction sequences used for entering of these modes will not affect the normal operation of the device.

$\overline{\text{PE}}/\text{SWD} = V_{\text{IL}}$  (logic low level): All power saving modes can be activated by software. When left unconnected, Pin  $\overline{\text{PE}}/\text{SWD}$  is pulled to high level by a weak internal pullup. This is done to provide system protection on default.

The logic-level applied to pin  $\overline{\text{PE}}/\text{SWD}$  can be changed during program execution to allow or to block the use of the power saving modes without any effect on the on-chip watchdog circuitry.

### Power Down Mode

The power down mode is entered by two consecutive instructions directly following each other. The first instruction has to set the flag PDE (power down enable) and must not set PDS (power down set). The following instruction has to set the start bit PDS. Bits PDE and PDS will automatically be cleared after having been set.

The instruction that sets bit PDS is the last instruction executed before going into power down mode. The only exit from power down mode is a hardware reset.

The status of all output lines of the controller can be looked up in **table 7**.

**Table 7**  
**Status of External Pins During Idle and Power Down**

Outputs	Last instruction executed from internal code memory		Last instruction executed from external code memory	
	Idle	Power down	Idle	Power Down
ALE	High	Low	High	Low
PSEN	High	Low	High	Low
Port 0	Data	Data	Float	Float
Port 1	Data/alternate outputs	Data/last output	Data/alternate outputs	Data/last output
Port 2	Data	Data	Address	Data
Port 3	Data/alternate outputs	Data/last output	Data/alternate outputs	Data/last output
Port 4	Data/alternate outputs	Data/last output	Data/alternate outputs	Data/last output
Port 5	Data/alternate outputs	Data/last output	Data/alternate outputs	Data/last output
Port 6	Data/alternate outputs	Data/last output	Data/alternate outputs	Data/last output

**Idle Mode**

During idle mode all peripherals of the SAB 80C517 are still supplied by the oscillator clock. Thus the user has to take care which peripheral should continue to run and which has to be stopped during Idle.

The procedure to enter the Idle mode is similar to entering the power down mode. The two bits IDLE and IDLS must be set by to consecutive instructions to minimize the chance of unintentional activating of the idle mode.

There are two ways to terminate the idle mode:

- The idle mode can be terminated by activating any enabled interrupt. This interrupt will be serviced and normally the instruction to be executed following the RETI instruction will be the one following the instruction that sets the bit IDLS.
- The other way to terminate the idle mode, is a hardware reset. Since the oscillator is still running, the hardware reset must be held active only for two machine cycles for a complete reset.

Normally the port pins hold the logical state they had at the time idle mode was activated. If some pins are programmed to serve their alternate functions they still continue to output during idle mode if the assigned function is on. The control signals ALE and PSEN hold at logic high levels (see **table 7**).

**Table 8**  
**Baud Rate Generation**

Function		Serial Interface 0		Serial Interface 1
8-Bit synchronous channel	<b>Mode</b>	<b>Mode 0</b>		–
	Baud rate *)	1 MHz @ $f_{OSC} = 12$ MHz		–
	Baud rate derived from	$f_{OSC}$		–
8-Bit UART	<b>Mode</b>	<b>Mode 1</b>		<b>Mode B</b>
	Baud rate *)	1 – 62.5 K	4800, 9600	1.5 – 375 K
	Baud rate derived from	Timer 1	BD	8-bit baud rate generator
9-Bit UART	<b>Mode</b>	<b>Mode 2</b>	<b>Mode 3</b>	<b>Mode A</b>
	Baud rate *)	187.5 K/ 375 K	1 – 62.5 K	1.5 – 375 K
	Baud rate derived from	$f_{OSC}/2$	Timer 1	8-bit baud rate generator

\*) Baud rate values are given for 12 MHz oscillator frequency.



## Serial Interface 0

Serial Interface 0 can operate in 4 modes:

- Mode 0: Shift register mode:  
Serial data enters and exits through RXD0. TXD0 outputs the shift clock 8 data bits are transmitted/received (LSB first). The baud rate is fixed at 1/12 of the oscillator frequency.
- Mode 1: 8-bit UART, variable baud rate:  
10-bit are transmitted (through TXD0) or received (through RXD0): a start bit (0), 8 data bits (LSB first), and a stop bit (1). On reception, the stop bit goes into RB80 in special function register S0CON. The baud rate is variable.
- Mode 2: 9-bit UART, fixed baud rate:  
11-bit are transmitted (through TXD0) or received (through RXD0): a start bit (0), 8 data bits (LSB first), a programmable 9th, and a stop bit (1). On transmission, the 9th data bit (TB80 in S0CON) can be assigned to the value of 0 or 1. For example, the parity bit (P in the PSW) could be moved into TB80 or a second stop bit by setting TB80 to 1. On reception the 9th data bit goes into RB80 in special function register S0CON, while the stop bit is ignored. The baud rate is programmable to either 1/32 or 1/64 of the oscillator frequency.
- Mode 3: 9-bit UART, variable baud rate:  
11-bit are transmitted (through TXD0) or received (through RXD0): a start bit (0), 8 data bits (LSB first), a programmable 9th, and a stop bit (1). In fact, mode 3 is the same as mode 2 in all respects except the baud rate. The baud rate in mode 3 is variable.

## Variable Baud Rates for Serial Interface 0

Variable baud rates for modes 1 and 3 of serial interface 0 can be derived from either timer 1 or from the oscillator via a special prescaler ("BD").

Timer 1 may be operated in mode 1 (to generate slow baud rates) or mode 2. The dedicated baud rate generator "BD" provides the two standard baud rates 4800 or 9600 baud with 0.16% deviation. **Table 8** shows possible configurations and the according baud rates.

SAB 80C517 devices with stepping code "CA" or later provide a dedicated baud rate generator for the serial interface 0. This baud rate generator is a free running 10-bit timer with programmable reload registers.

$$\text{Mode 1.3 baud rate} = \frac{2^{\text{SMOD}} \times f_{\text{OSC}}}{64 \times (2^{10} - \text{S0REL})}$$

The default value after reset in the reload registers S0RELL and S0RELH provide a baud rate of 4.8 kBaud (SMOD = 0) or 9.6 kBaud (SMOD = 1) at 12 MHz oscillator frequency. This guarantees full compatibility to the SAB 80C517 older steppings.

## Serial Interface 1

Serial interface 1 can operate in two asynchronous modes:

Mode A: 9-bit UART, variable baud rate.  
11 bits are transmitted (through TXD0) or received (through RXD0): a start bit (0), 8 data bits (LSB first), a programmable 9th, and a stop bit (1). On transmission, the 9<sup>th</sup> data bit (TB81 in S1CON) can be assigned to the value of 0 or 1. For example, the parity bit (P in the PSW) could be moved into TB81 or a second stop bit by setting TB81 to 1. On reception the 9<sup>th</sup> data bit goes into RB81 in special function register S1CON, while the stop bit is ignored.

Mode B: 8-bit UART, variable baud rate.  
10 bits are transmitted (through TXD1) or received (through RXD1): a start bit (0), 8 data bits (LSB first), and a stop bit (1). On reception, the stop bit goes into RB81 in special function register S1CON.

### Variable Baud Rates for Serial Interface 1

Variable baud rates for modes A and B of serial interface 1 can be derived from a dedicated baud rate generator.

The baud rate clock (baud rate =  $\frac{\text{baud rate clock}}{16}$ ) is generated by a 8-bit free

running timer with programmable reload register. SAB 80C517 devices with stepping code "CA" or later provide a 10-bit free running timer for baud rate generation.

$$\text{Mode A, B baud rate} = \frac{f_{\text{OSC}}}{32 \times \left( 2^{10} - \text{Reload Value} \right)}$$

### Watchdog Units

The SAB 80C517 offers two enhanced fail safe mechanisms, which allow an automatic recovery from hardware failure or software upset:

- programmable watchdog timer (WDT), variable from 512 ms up to about 1.1 s time out period @12 MHz. Upward compatible to SAB 80515 watchdog.
- oscillator watchdog (OWD), monitors the on-chip oscillator and forces the microcontroller to go into reset state, in case the on-chip oscillator fails.

### Programmable Watchdog Timer

The WDT can be activated by hardware or software.

Hardware initialization is done when pin  $\overline{\text{PE}}/\text{SWD}$  (Pin 4) is held high during RESET. The SAB 80C517 then starts program execution with the WDT running. Pin  $\overline{\text{PE}}/\text{SWD}$  doesn't allow dynamic switching of the WDT.

Software initialization is done by setting bit SWDT. A refresh of the watchdog timer is done by setting bits WDT and SWDT consecutively.

A block diagram of the watchdog timer is shown in **figure 11**.

When a watchdog timer reset occurs, the watchdog timer keeps on running, but a status flag WDTS is set. This flag can also be manipulated by software.



### Instruction Set Summary

The SAB 80C517/80C537 has the same instruction set as the industry standard 8051 microcontroller.

A pocket guide is available which contains the complete instruction set in functional and hexadecimal order. Furtheron it provides helpful information about Special Function Registers, Interrupt Vectors and Assembler Directives.

### Literature Information

Title	Ordering No.
Microcontroller Family SAB 8051 Pocket Guide	B158-H6497-X-X-7600

**Absolute Maximum Ratings**

Ambient temperature under bias

SAB 80C517/83C537 .....	0 to 70 °C
SAB 80C517/83C537-T40/85.....	- 40 to 85 °C
Storage temperature $T_{ST}$ .....	- 65 to 150 °C
Voltage on $V_{CC}$ pins with respect to ground ( $V_{SS}$ ) .....	- 0.5 V to 6.5 V
Voltage on any pin with respect to ground ( $V_{SS}$ ).....	- 0.5 to $V_{CC} + 0.5$ V
Input current on any pin during overload condition .....	- 10mA to +10mA
Absolute sum of all input currents during overload condition.....	100mA
Power dissipation .....	2 W

**Note** Stresses above those listed under "Absolute Maximum Ratings" may cause permanent damage of the device. This is a stress rating only and functional operation of the device at these or any other conditions above those indicated in the operational sections of this specification is not implied. Exposure to absolute maximum rating conditions for longer periods may affect device reliability. During overload conditions ( $V_{IN} > V_{CC}$  or  $V_{IN} < V_{SS}$ ) the voltage on  $V_{CC}$  pins with respect to ground ( $V_{SS}$ ) must not exceed the values defined by the absolute maximum ratings.

**DC Characteristics**

$V_{CC} = 5\text{ V} \pm 10\%$ ;  $V_{SS} = 0\text{ V}$ ;

$T_A = 0\text{ to }70\text{ °C}$  for the SAB 80C517/83C537

$T_A = -40\text{ to }85\text{ °C}$  for the SAB 80C517-/83C537-T40/85

Parameter	Symbol	Limit Values		Unit	Test Condition
		min.	max.		
Input low voltage (except $\overline{EA}$ )	$V_{IL}$	- 0.5	$0.2 V_{CC} - 0.1$	V	-
Input low voltage ( $\overline{EA}$ )	$V_{IL1}$	- 0.5	$0.2 V_{CC} - 0.3$	V	-
Input high voltage	$V_{IH}$	$0.2 V_{CC} + 0.9$	$V_{CC} + 0.5$	V	-
Input high voltage to XTAL2	$V_{IH1}$	$0.7 V_{CC}$	$V_{CC} + 0.5$	V	-
Input high voltage to $\overline{RESET}$	$V_{IH2}$	$0.6 V_{CC}$	$V_{CC} + 0.5$	V	-
Output low voltage (ports 1, 2, 3, 4, 5, 6)	$V_{OL}$	-	0.45	V	$I_{OL} = 1.6\text{ mA}^{1)}$

Notes see page 47.

DC Characteristics (cont'd)

Parameter	Symbol	Limit Values		Unit	Test Condition
		min.	max.		
Output low voltage (ports ALE, $\overline{\text{PSEN}}$ , $\overline{\text{RO}}$ )	$V_{OL1}$	–	0.45	V	$I_{OL} = 3.2\text{mA}^1)$
Output high voltage (ports 1, 2, 3, 4, 5, 6)	$V_{OH}$	2.4	–	V	$I_{OH} = -80\ \mu\text{A}$
		$0.9 V_{CC}$	–	V	$I_{OH} = -10\ \mu\text{A}$
Output high voltage (port 0 in external bus mode, ALE, $\overline{\text{PSEN}}$ , $\overline{\text{RO}}$ )	$V_{OH1}$	2.4	–	V	$I_{OH} = -800\ \mu\text{A}^2)$
		$0.9 V_{CC}$	–	V	$I_{OH} = -80\ \mu\text{A}^2)$
Logic 0 input current (ports 1, 2, 3, 4, 5, 6)	$I_{IL}$	– 10	– 70	$\mu\text{A}$	$V_{IN} = 0.45\ \text{V}$
Input low current to $\overline{\text{RESET}}$ for reset	$I_{IL2}$	– 10	–100	$\mu\text{A}$	$V_{IN} = 0.45\ \text{V}$
Input low current (XTAL2)	$I_{IL3}$	–	– 15	$\mu\text{A}$	$V_{IN} = 0.45\ \text{V}$
Input low current (OWE, PE/SWD)	$I_{IL4}$	–	– 20	$\mu\text{A}$	$V_{IN} = 0.45\ \text{V}$
Logical 1-to-0 transition current (ports 1, 2, 3, 4, 5, 6)	$I_{TL}$	– 65	– 650	$\mu\text{A}$	$V_{IN} = 2\ \text{V}$
Input leakage current (port 0, $\overline{\text{EA}}$ , ports 7, 8)	$I_{LI}$	–	$\pm 1$	$\mu\text{A}$	$0.45 < V_{IN} < V_{CC}^{10)}$
Pin capacitance	$C_{IO}$	–	10	pF	$f_C = 1\ \text{MHz}$ $T_A = 25\ ^\circ\text{C}$
Power supply current: Active mode, 12 MHz <sup>6)</sup>	$I_{CC}$	–	40	mA	$V_{CC} = 5\ \text{V},^4)$
Idle mode, 12 MHz <sup>6)</sup>		–	15	mA	$V_{CC} = 5\ \text{V},^5)$
Slow down mode, 12 MHz <sup>6)</sup>		–	15	mA	$V_{CC} = 5\ \text{V},^5)$
Active mode, 16 MHz <sup>6)</sup>	$I_{CC}$	–	52.3	mA	$V_{CC} = 5\ \text{V},^4)$
Idle mode, 16 MHz <sup>6)</sup>		–	19	mA	$V_{CC} = 5\ \text{V},^5)$
Slow down mode, 16MHz <sup>6)</sup>		–	19	mA	$V_{CC} = 5\ \text{V},^5)$
Power down Mode	$I_{PD}$	–	50	$\mu\text{A}$	$V_{CC} = 2\dots 5.5\ \text{V}^3)$

Notes see page 47.

## A/D Converter Characteristics

$$V_{CC} = 5 \text{ V} \pm 10\%; V_{SS} = 0 \text{ V}$$

$$V_{AREF} = V_{CC} \pm 5\%; V_{AGND} = V_{SS} \pm 0.2 \text{ V}; V_{IntAREF} - V_{IntAGND} \geq 1 \text{ V}$$

$$T_A = 0 \text{ to } 70 \text{ }^\circ\text{C} \text{ for the SAB 80C517/83C537}$$

$$T_A = -40 \text{ to } 85 \text{ }^\circ\text{C} \text{ for the SAB 80C517/83C537-T40/875}$$

Parameter	Symbol	Limit values			Unit	Test Condition
		min.	typ.	max.		
Analog input voltage	$V_{AINPUT}$	$V_{AGND} - 0.2$	–	$V_{AREF} + 0.2$	V	9)
Analog input capacitance	$C_I$	–	25	60	pF	7)
Load time	$t_L$	–	–	$2 t_{CY}$	$\mu\text{s}$	7)
Sample time (incl. load time)	$t_S$	–	–	$7 t_{CY}$	$\mu\text{s}$	7)
Conversion time (incl. sample time)	$t_C$	–	–	$13 t_{CY}$	$\mu\text{s}$	7)
Total unadjusted error	TUE	–		$\pm 2$	LSB	$V_{AREF} = V_{CC}$ $V_{AGND} = V_{SS}$ 11)
Internal reference error	$V_{IntREFERR}$	–		$\pm 30$	mV	8)
$V_{AREF}$ supply current	$I_{REF}$	–	–	5	mA	8)

Notes see page 47.

**Notes** for pages 44, 45 and 46:

- 1) Capacitive loading on ports 0 and 2 may cause spurious noise pulses to be superimposed on the  $V_{OL}$  of ALE and ports 1, 3, 4, 5 and 6. The noise is due to external bus capacitance discharging into the port 0 and port 2 pins when these pins make 1-to-0 transitions during bus operation.  
In the worst case (capacitive loading > 100 pF), the noise pulse on ALE line may exceed 0.8 V. In such cases it may be desirable to qualify ALE with a schmitt-trigger, or use an address latch with a schmitt- trigger strobe input.
- 2) Capacitive loading on ports 0 and 2 may cause the  $V_{OH}$  on ALE and  $\overline{PSEN}$  to momentarily fall below the 0.9  $V_{CC}$  specification when the address lines are stabilizing.
- 3) Power down  $I_{PD}$  is measured with all output pins disconnected;  
 $\overline{EA} = \overline{RESET} = V_{CC}$ ; Port 0 = Port 7 = Port 8 =  $V_{CC}$ ; XTAL1 = N.C.; XTAL2 =  $V_{SS}$ ;  
 $V_{AGND} = \text{N.C.}$ ;  $V_{AREF} = V_{CC}$ ;  $\overline{PE}/\text{SWD} = \text{OWE} = V_{SS}$ .
- 4)  $I_{CC}$  (active mode) is measured with all output pins disconnected; XTAL2 driven with clock signal according to the figure below; XTAL1 = N.C.;  
 $\overline{EA} = \text{OWE} = \overline{PE}/\text{SWD} = V_{CC}$ ; Port 0 = Port 7 = Port 8 =  $V_{CC}$ ;  
 $\overline{RESET} = V_{SS}$ .  $I_{CC}$  would be slightly higher if a crystal oscillator is used.
- 5)  $I_{CC}$  (idle mode,) is measured with all output pins disconnected and with all peripherals disabled; XTAL2 driven with clock signal according to the figure below; XTAL1 = N.C.;  
 $\overline{RESET} = \text{OWE} = V_{CC}$ ; Port 0 = Port 7 = Port 8 =  $V_{CC}$ ;  $\overline{EA} = \overline{PE}/\text{SWD} = V_{SS}$ .  
 $I_{CC}$  (slow down mode) is measured with all output pins disconnected and with all peripherals disabled; XTAL2 driven with clock signal according to the figure below; XTAL = N.C.;  
Port 7 = Port 8 =  $V_{CC}$ ;  $\overline{EA} = \overline{PE}/\text{SWD} = V_{SS}$ .
- 6)  $I_{CC}$  (max.) at other frequencies is given by: active mode:  $I_{CC} \text{ max} = 3.1 * f_{OSC} + 3.0$   
idle mode:  $I_{CC} \text{ max} = 1.0 * f_{OSC} + 3.0$   
Where  $f_{OSC}$  is the oscillator frequency in MHz.  $I_{CC}$  values are given in mA and measured at  $V_{CC} = 5 \text{ V}$  (**see also notes 4 and 5**).
- 7) The output impedance of the analog source must be low enough to assure full loading of the sample capacitance ( $C_I$ ) during load time ( $T_L$ ). After charging of the internal capacitance ( $C_I$ ) in the load time ( $T_L$ ) the analog input must be held constant for the rest of the sample time ( $T_S$ ).
- 8) The differential impedance  $R_D$  of the analog reference voltage source must be less than 1 k $\Omega$  at reference supply voltage.
- 9) Exceeding the limit values at one or more input channels will cause additional current which is sinked sourced at these channels. This may also affect the accuracy of other channels which are operated within the specification.
- 10) Only valid for not selected analog inputs.
- 11) No missing code.



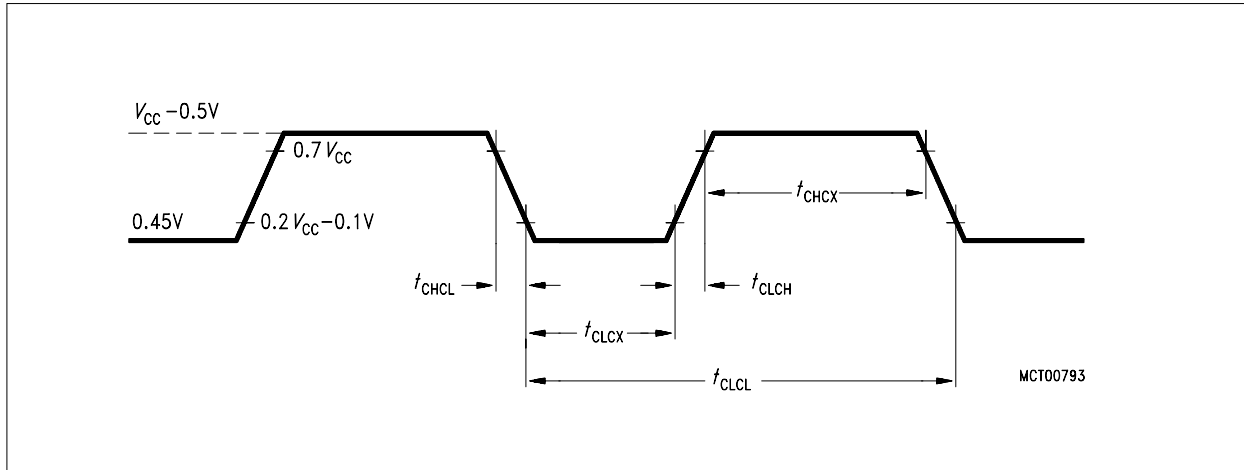

**Clock of Waveform for  $I_{CC}$  Tests in Active, Idle Mode and Slow Down Mode**

## AC Characteristics

$V_{CC} = 5 \text{ V} \pm 10 \%$ ;  $V_{SS} = 0 \text{ V}$   $T_A = 0 \text{ to } 70 \text{ }^\circ\text{C}$  for the SAB 80C517/83C537  
 $T_A = -40 \text{ to } 85 \text{ }^\circ\text{C}$  for the SAB 80C517/83C537-T40/85  
 ( $C_L$  for port 0, ALE and  $\overline{\text{PSEN}}$  outputs = 100 pF;  $C_L$  for all other outputs = 80 pF)

Parameter	Symbol	Limit Values				Unit
		12 MHz Clock		Variable Clock $1/t_{CLCL} = 3.5 \text{ MHz to } 12 \text{ MHz}$		
		min	max.	min.	max.	

## Program Memory Characteristics

ALE pulse width	$t_{LHLL}$	127	–	$2 t_{CLCL} - 40$	–	ns
Address setup to ALE	$t_{AVLL}$	53	–	$t_{CLCL} - 30$	–	ns
Address hold after ALE	$t_{LLAX}$	48	–	$t_{CLCL} - 35$	–	ns
ALE to valid instruction in	$t_{LLIV}$	–	233	–	$4t_{CLCL} - 100$	ns
ALE to $\overline{\text{PSEN}}$	$t_{LLPL}$	58	–	$t_{CLCL} - 25$	–	ns
$\overline{\text{PSEN}}$ pulse width	$t_{PLPH}$	215	–	$3 t_{CLCL} - 35$	–	ns
$\overline{\text{PSEN}}$ to valid instruction in	$t_{PLIV}$	–	150	–	$3t_{CLCL} - 100$	ns
Input instruction hold after $\overline{\text{PSEN}}$	$t_{PXIX}$	0	–	0		ns
Input instruction float after $\overline{\text{PSEN}}$ *)	$t_{PXIX}^*)$	–	63	–	$t_{CLCL} - 20$	ns
Address valid after $\overline{\text{PSEN}}$ *)	$t_{PXAV}^*)$	75	–	$t_{CLCL} - 8$	–	ns
Address to valid instruction in	$t_{AVIV}$	–	302	0	$5t_{CLCL} - 115$	ns
Address float to $\overline{\text{PSEN}}$	$t_{AZPL}$	–	–	–		ns

\*) Interfacing the SAB 80C517 to devices with float times up to 75 ns is permissible.  
 This limited bus contention will not cause any damage to port 0 drivers.

AC Characteristics (cont'd)

Parameter	Symbol	Limit Values				Unit
		12 MHz Clock		Variable Clock 1/t <sub>CLCL</sub> = 3.5 MHz to 12 MHz		
		min	max.	min.	max.	

External Data Memory Characteristics

$\overline{\text{RD}}$ pulse width	t <sub>RLRH</sub>	400	–	6 t <sub>CLCL</sub> – 100	–	ns
$\overline{\text{WR}}$ pulse width	t <sub>WLWH</sub>	400	–	6 t <sub>CLCL</sub> – 100	–	ns
Address hold after ALE	t <sub>LLAX2</sub>	132	–	2 t <sub>CLCL</sub> – 30	–	ns
$\overline{\text{RD}}$ to valid instr in	t <sub>RLDV</sub>	–	252	–	5 t <sub>CLCL</sub> – 165	ns
Data hold after $\overline{\text{RD}}$	t <sub>RHDX</sub>	0	–	0	–	ns
Data float after $\overline{\text{RD}}$	t <sub>RHDZ</sub>	–	97	–	2 t <sub>CLCL</sub> – 70	ns
ALE to valid data in	t <sub>LLDV</sub>	–	517	–	8 t <sub>CLCL</sub> – 150	ns
Address to valid data in	t <sub>AVDV</sub>	–	585	–	9 t <sub>CLCL</sub> – 165	ns
ALE to $\overline{\text{WR}}$ or $\overline{\text{RD}}$	t <sub>LLWL</sub>	200	300	3 t <sub>CLCL</sub> – 50	3 t <sub>CLCL</sub> + 50	ns
$\overline{\text{WR}}$ or $\overline{\text{RD}}$ high to ALE high	t <sub>WHLH</sub>	43	123	t <sub>CLCL</sub> – 40	t <sub>CLCL</sub> + 40	ns
Address valid to $\overline{\text{WR}}$	t <sub>AVWL</sub>	203	–	4 t <sub>CLCL</sub> – 130	–	ns
Data valid to $\overline{\text{WR}}$ transition	t <sub>QVWX</sub>	33	–	t <sub>CLCL</sub> – 50	–	ns
Data setup before $\overline{\text{WR}}$	t <sub>QVWX</sub>	433	–	7 t <sub>CLCL</sub> – 150	–	ns
Data hold after $\overline{\text{WR}}$	t <sub>WHQX</sub>	33	–	t <sub>CLCL</sub> – 50	–	ns
Address float after $\overline{\text{RD}}$	t <sub>RLAZ</sub>	–	0	–	0	ns

### AC Characteristics

$V_{CC} = 5\text{ V} \pm 10\%$ ;  $V_{SS} = 0\text{ V}$

$T_A = 0\text{ to }70\text{ }^\circ\text{C}$  for the SAB 80C517-16/83C537-16

$T_A = -40\text{ to }85\text{ }^\circ\text{C}$  for the SAB 80C517-16/83C537-16-T40/85

( $C_L$  for port 0, ALE and  $\overline{\text{PSEN}}$  outputs = 100pF;  $C_L$  for all outputs = 80 pF)

Parameter	Symbol	Limit Values				Unit
		16 MHz Clock		Variable Clock $1/t_{CLCL} = 3.5\text{ MHz to }16\text{ MHz}$		
		min	max.	min.	max.	

### Program Memory Characteristics

ALE pulse width	$t_{LHLL}$	85	–	$2 t_{CLCL} - 40$	–	ns
Address setup to ALE	$t_{AVLL}$	33	–	$t_{CLCL} - 30$	–	ns
Address hold after ALE	$t_{LLAX}$	28	–	$t_{CLCL} - 35$	–	ns
ALE to valid instr. in	$t_{LLIV}$	–	150	–	$4t_{CLCL} - 100$	ns
ALE to $\overline{\text{PSEN}}$	$t_{LLPL}$	38	–	$t_{CLCL} - 25$	–	ns
$\overline{\text{PSEN}}$ pulse width	$t_{PLPH}$	153	–	$3 t_{CLCL} - 35$	–	ns
$\overline{\text{PSEN}}$ to valid instr. in	$t_{PLIV}$	–	88	–	$3t_{CLCL} - 100$	ns
Input instruction hold after $\overline{\text{PSEN}}$	$t_{PXIX}$	0	–	0	–	ns
Input instruction float *) after $\overline{\text{PSEN}}$	$t_{PXIZ}$	–	43	–	$t_{CLCL} - 20$	ns
Address valid after $\overline{\text{PSEN}}$ *)	$t_{PXAV}$	55	–	$t_{CLCL} - 8$	–	ns
Address to valid instr. in	$t_{AVIV}$	–	198	0–	$5t_{CLCL} - 115$	ns
Address float to $\overline{\text{PSEN}}$	$t_{AZPL}$	0	–	0	–	ns

\*) Interfacing the SAB 80C517 to devices with float times up to 55 ns is permissible. This limited bus contention will not cause any damage to port 0 drivers.

AC Characteristics (cont'd)

Parameter	Symbol	Limit Values				Unit
		16 MHz Clock		Variable Clock 1/t <sub>CLCL</sub> = 3.5 MHz to 16 MHz		
		min	max.	min.	max.	

External Data Memory Characteristics

$\overline{RD}$ pulse width	$t_{RLRH}$	275	–	$6 t_{CLCL} - 100$	–	ns
$\overline{WR}$ pulse width	$t_{WLWH}$	275	–	$6 t_{CLCL} - 100$	–	ns
Address hold after ALE	$t_{LLAX2}$	90	–	$2 t_{CLCL} - 35$	–	ns
$\overline{RD}$ to valid data in	$t_{RLDV}$	–	148	–	$5 t_{CLCL} - 165$	ns
Data hold after $\overline{RD}$	$t_{RHDX}$	0	–	0	–	ns
Data float after $\overline{RD}$	$t_{RHDZ}$	–	55	–	$2 t_{CLCL} - 70$	ns
ALE to valid data in	$t_{LLDV}$	–	350	–	$8 t_{CLCL} - 150$	ns
Address to valid data in	$t_{AVDV}$	–	398	–	$9 t_{CLCL} - 165$	ns
ALE to $\overline{WR}$ or $\overline{RD}$	$t_{LLWL}$	138	238	$3 t_{CLCL} - 50$	$3 t_{CLCL} + 50$	ns
$\overline{WR}$ or $\overline{RD}$ high to ALE high	$t_{WHLH}$	23	103	$t_{CLCL} - 40$	$t_{CLCL} + 40$	ns
Address valid to $\overline{WR}$	$t_{AVWL}$	120	–	$4 t_{CLCL} - 130$	–	ns
Data valid to $\overline{WR}$ transition	$t_{QVWX}$	13	–	$t_{CLCL} - 50$	–	ns
Data setup before $\overline{WR}$	$t_{QVWH}$	288	–	$7 t_{CLCL} - 150$	–	ns
Data hold after $\overline{WR}$	$t_{WHQX}$	13	–	$t_{CLCL} - 50$	–	ns
Address float after $\overline{RD}$	$t_{RLAZ}$	–	0	–	0	ns

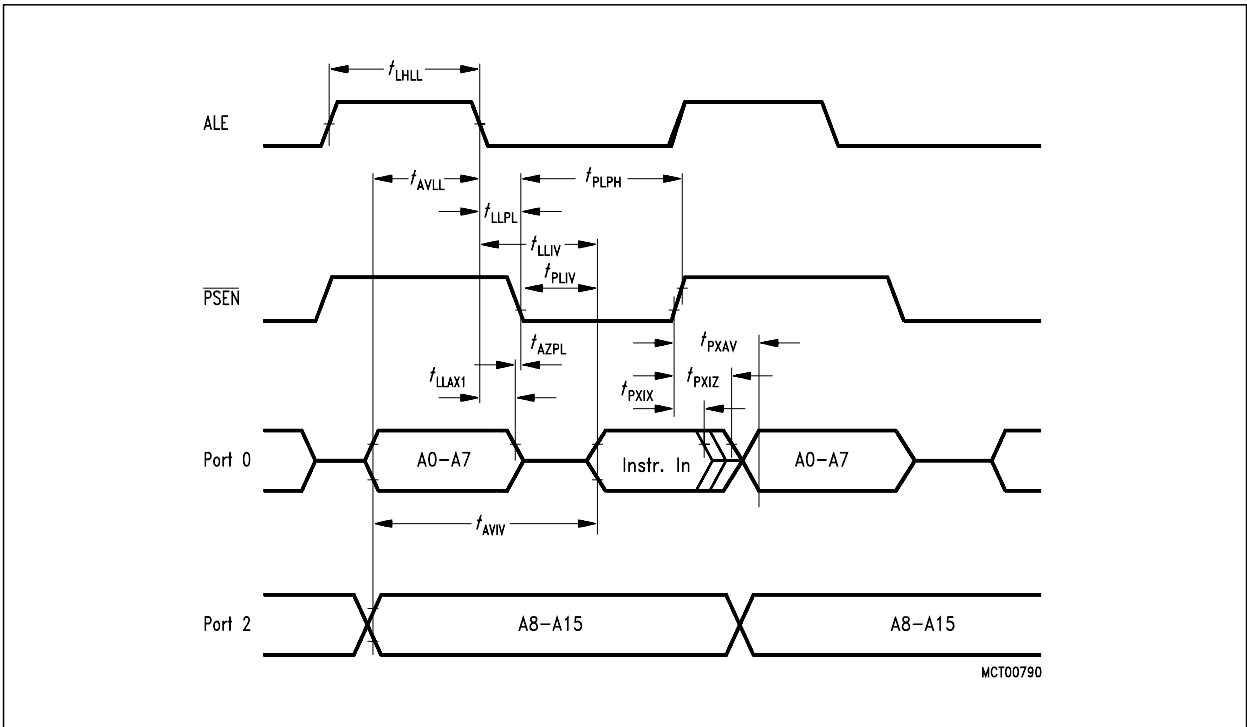

Program Memory Read Cycle

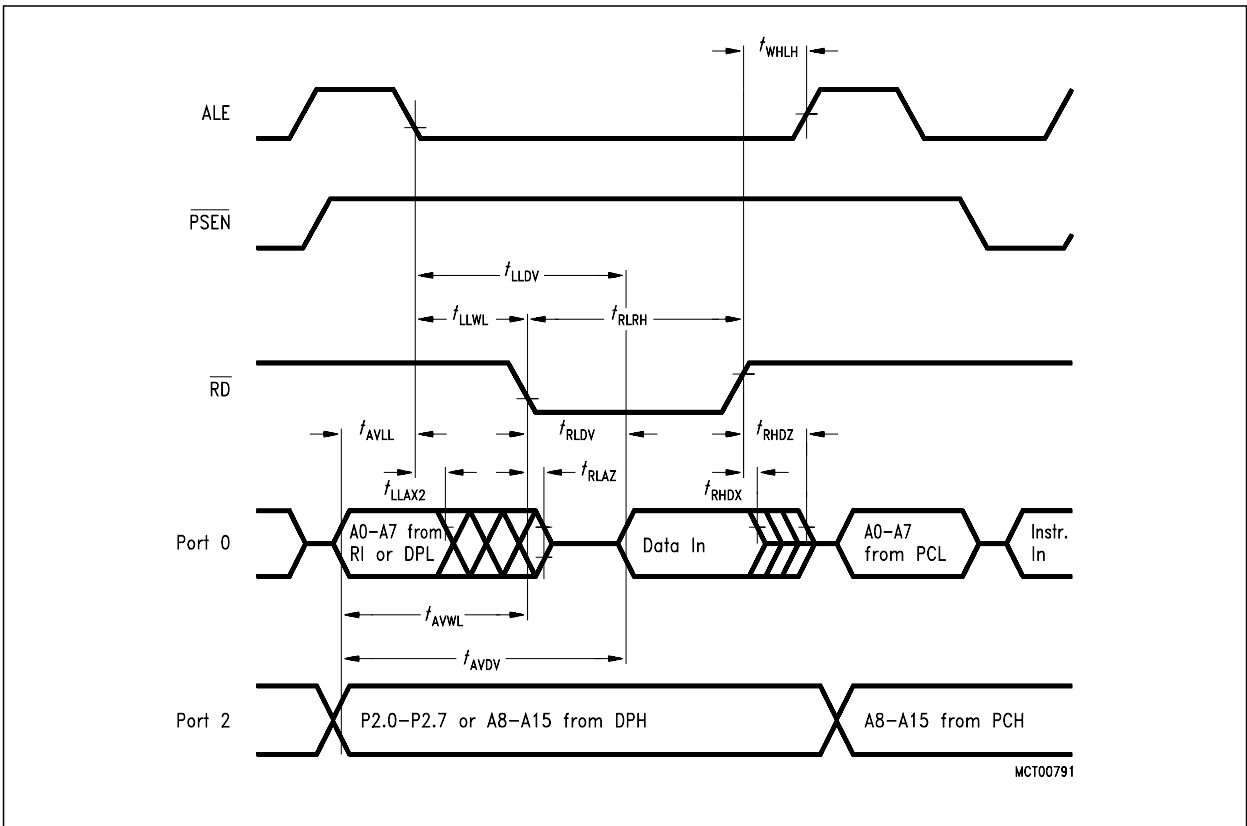

Data Memory Read Cycle

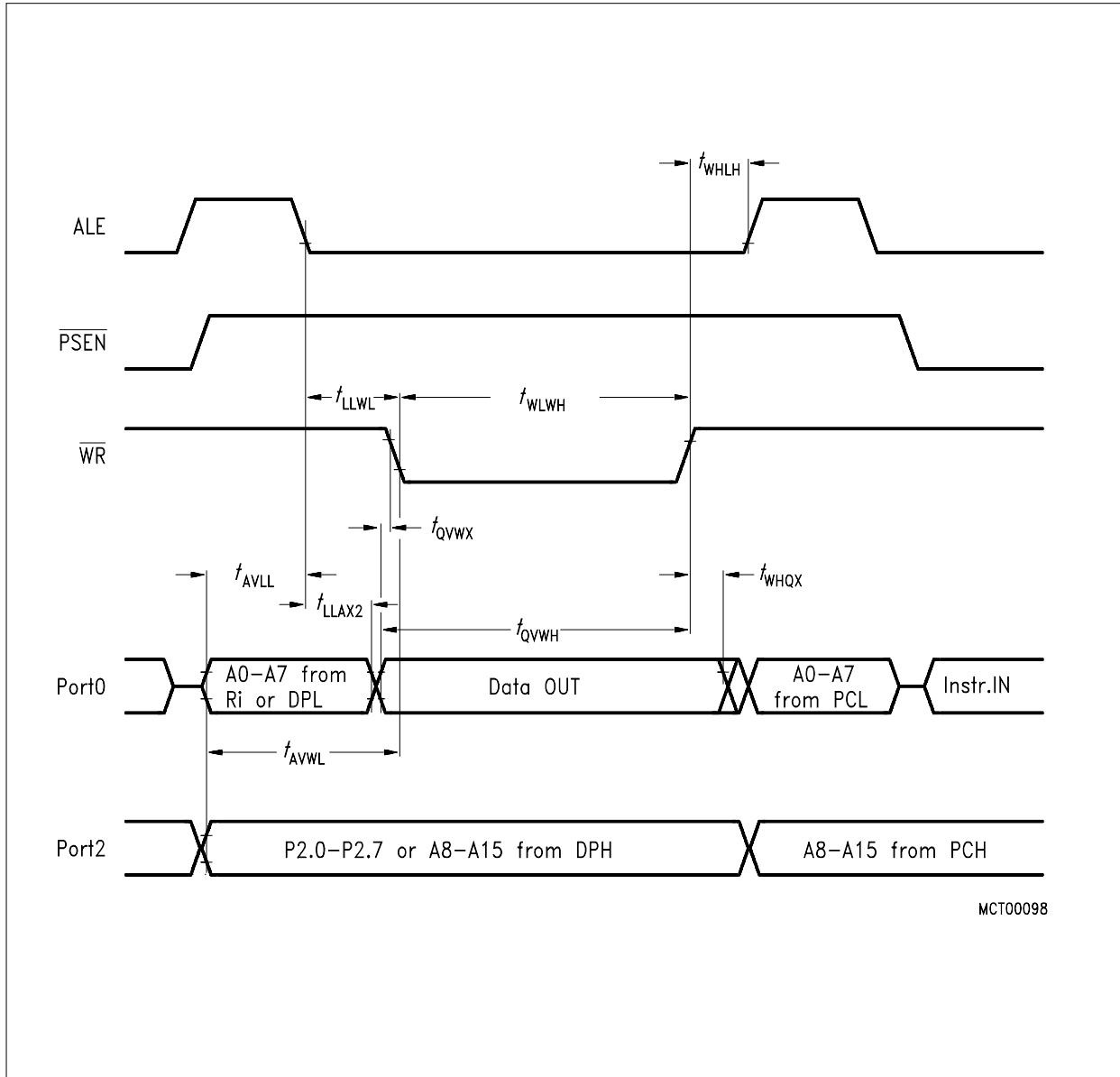

Data Memory Write Cycle

**AC Characteristics (cont'd)**

Parameter	Symbol	Limit Values		Unit
		Variable Clock Frequ. = 3.5 MHz to 12 MHz		
		min	max.	

**External Clock Drive**

Oscillator period	$t_{CLCL}$	83.3	285	ns
Oscillator frequency	$1/t_{CLCL}$	3.5	12	MHz
High time	$t_{CHCX}$	20	–	ns
Low time	$t_{CLCX}$	20	–	ns
Rise time	$t_{CLCH}$	–	20	ns
Fall time	$t_{CHCL}$	–	20	ns

**AC Characteristics (cont'd)**

Parameter	Symbol	Limit Values		Unit
		Variable Clock Frequ. = 1 MHz to 16 MHz		
		min	max.	

**External Clock Drive**

Oscillator period	$t_{CLCL}$	62.5	285	ns
Oscillator frequency	$1/t_{CLCL}$	3.5	16	MHz
High time	$t_{CHCX}$	25	–	ns
Low time	$t_{CLCX}$	25	–	ns
Rise time	$t_{CLCH}$	–	20	ns
Fall time	$t_{CHCL}$	–	20	ns



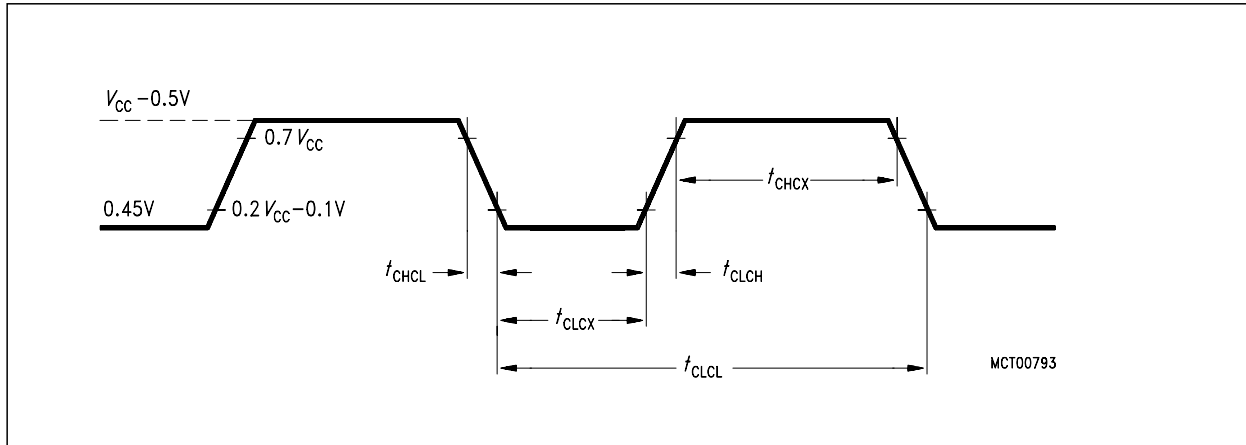

External Clock Cycle

### AC Characteristics (cont'd)

Parameter	Symbol	Limit Values				Unit
		12 MHz Clock		Variable Clock $1/t_{CLCL} = 3.5 \text{ MHz to } 12 \text{ MHz}$		
		min.	max.	min.	max.	

### System Clock Timing

ALE to CLKOUT	$t_{LLSH}$	543	–	$7t_{CLCL} - 40$	–	ns
CLKOUT high time	$t_{SHSL}$	127	–	$2t_{CLCL} - 40$	–	ns
CLKOUT low time	$t_{SLSH}$	793	–	$10t_{CLCL} - 40$	–	ns
CLKOUT low to ALE high	$t_{SLLH}$	43	123	$t_{CLCL} - 40$	$t_{CLCL} + 40$	ns

### AC Characteristics (cont'd)

Parameter	Symbol	Limit Values				Unit
		16 MHz Clock		Variable Clock $1/t_{CLCL} = 3.5 \text{ MHz to } 16 \text{ MHz}$		
		min.	max.	min.	max.	

### System Clock Timing

ALE to CLKOUT	$t_{LLSH}$	398	–	$7t_{CLCL} - 40$	–	ns
CLKOUT high time	$t_{SHSL}$	85	–	$2t_{CLCL} - 40$	–	ns
CLKOUT low time	$t_{SLSH}$	585	–	$10t_{CLCL} - 40$	–	ns
CLKOUT low to ALE high	$t_{SLLH}$	23	103	$t_{CLCL} - 40$	$t_{CLCL} + 40$	ns

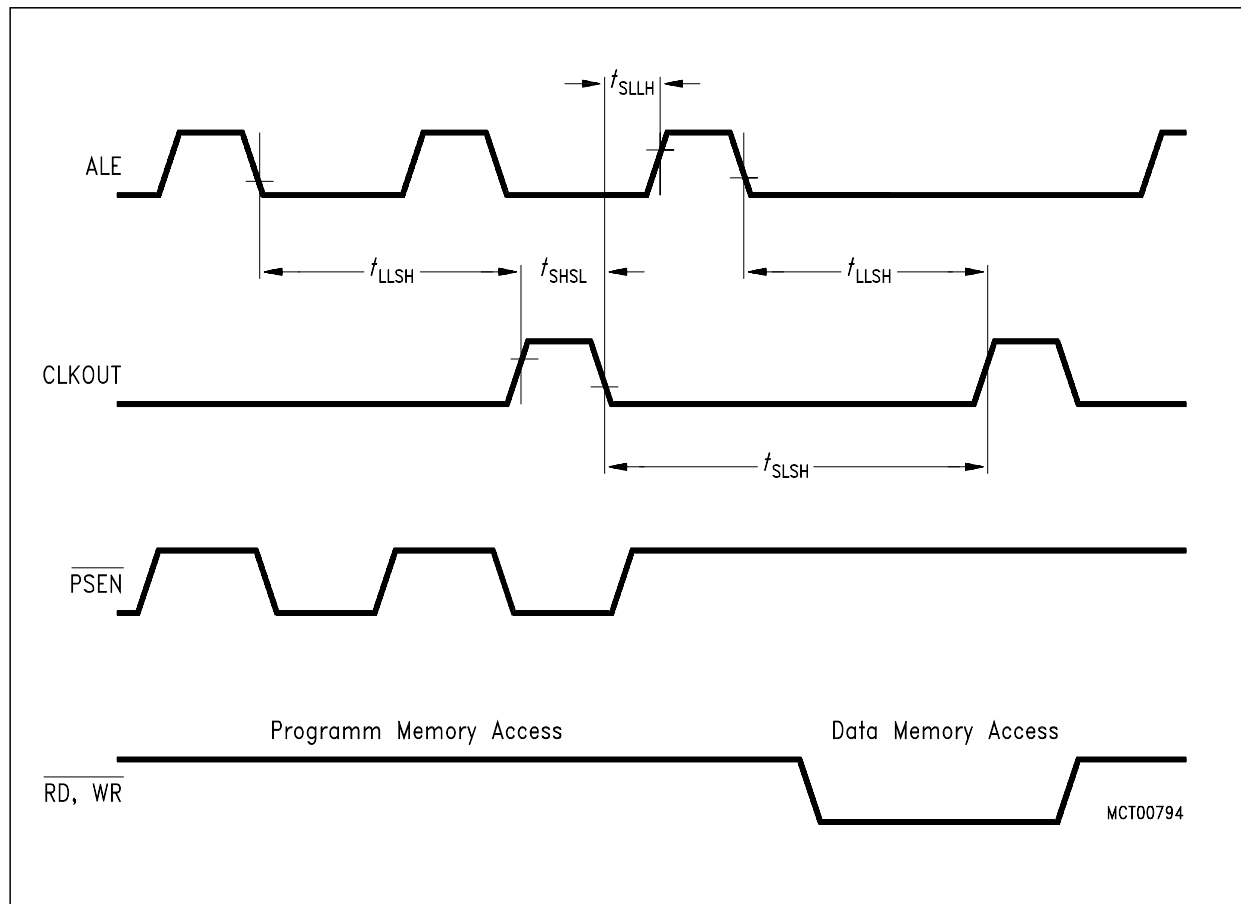

System Clock Timing

**ROM Verification Characteristics**

$T_A = 25^\circ\text{C} \pm 5^\circ\text{C}$ ;  $V_{CC} = 5\text{ V} \pm 10\%$ ;  $V_{SS} = 0\text{ V}$

Parameter	Symbol	Limit values		Unit
		min	max.	

**ROM Verification**

Address to valid data	$t_{AVQV}$	–	$48 t_{CLCL}$	ns
ENABLE to valid data	$t_{ELQV}$	–	$48 t_{CLCL}$	ns
Data float after ENABLE	$t_{EHQZ}$	0	$48 t_{CLCL}$	ns
Oscillator frequency	$1/t_{CLCL}$	4	6	MHz

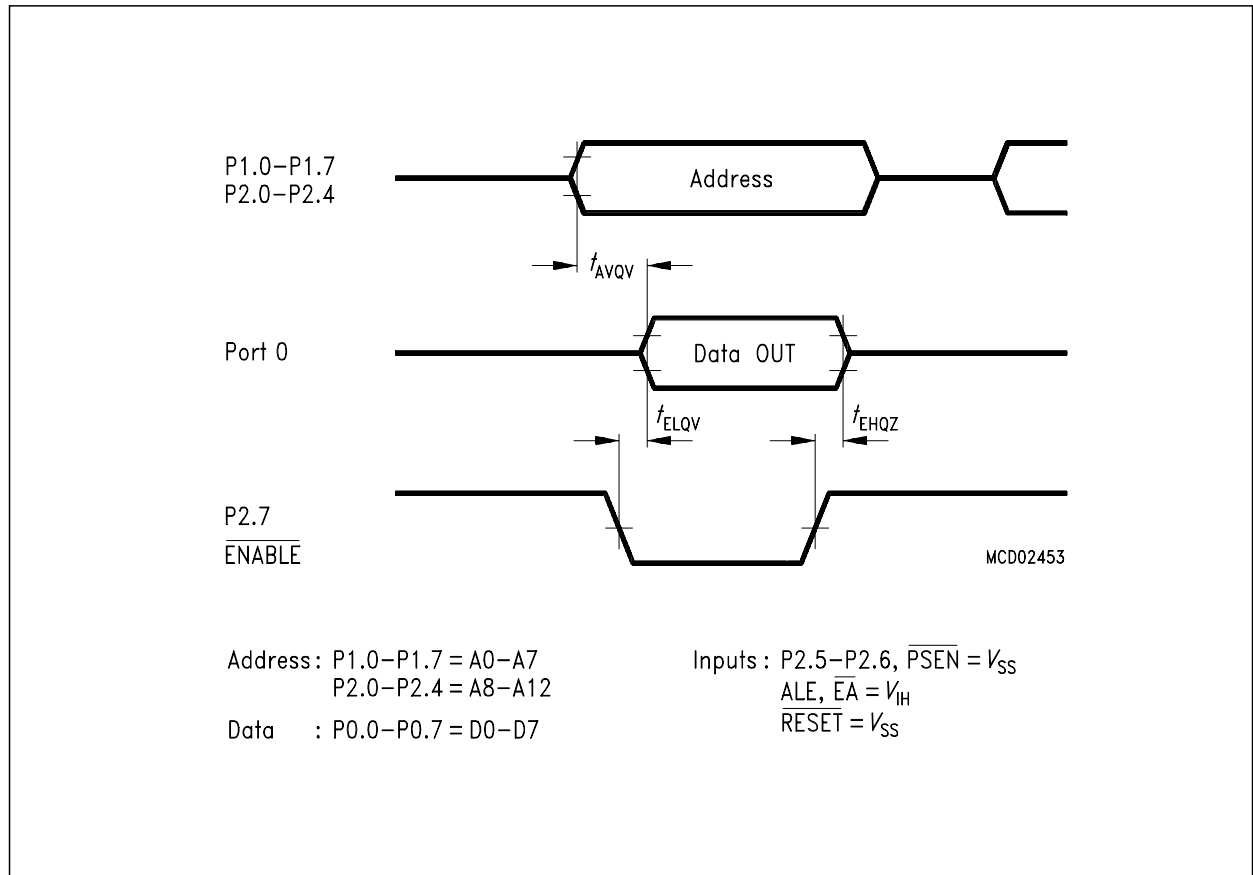

**ROM Verification**

For timing purposes a port pin is no longer floating when a 100 mV change from load voltage occurs and begins to float when a 100 mV change from the loaded  $V_{OH}/V_{OL}$  level occurs.  $I_{OL}/I_{OH} \geq \pm 20\text{ mA}$ .

Recommended Oscillator Circuits

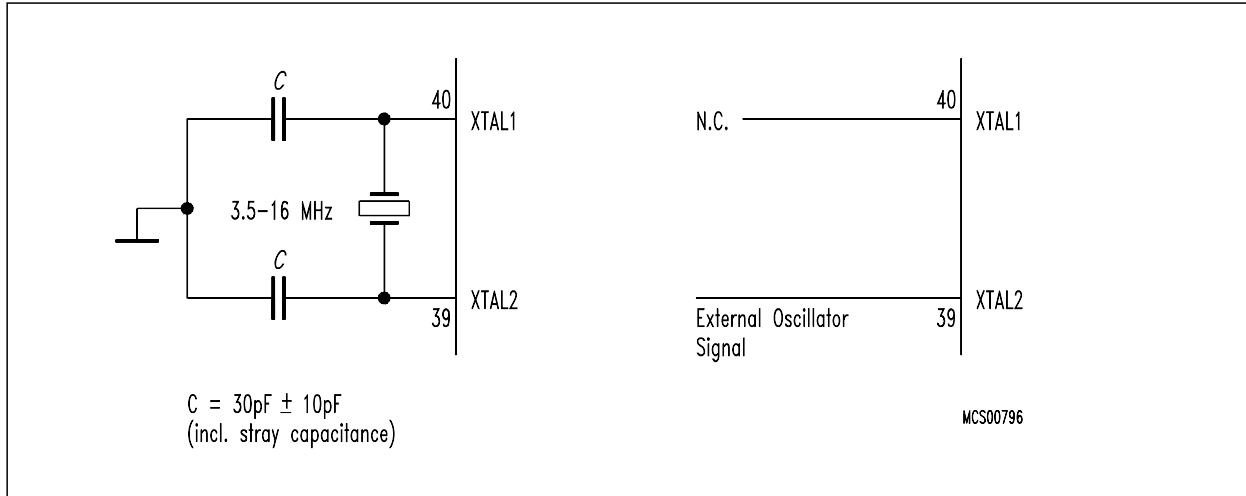

AC Testing

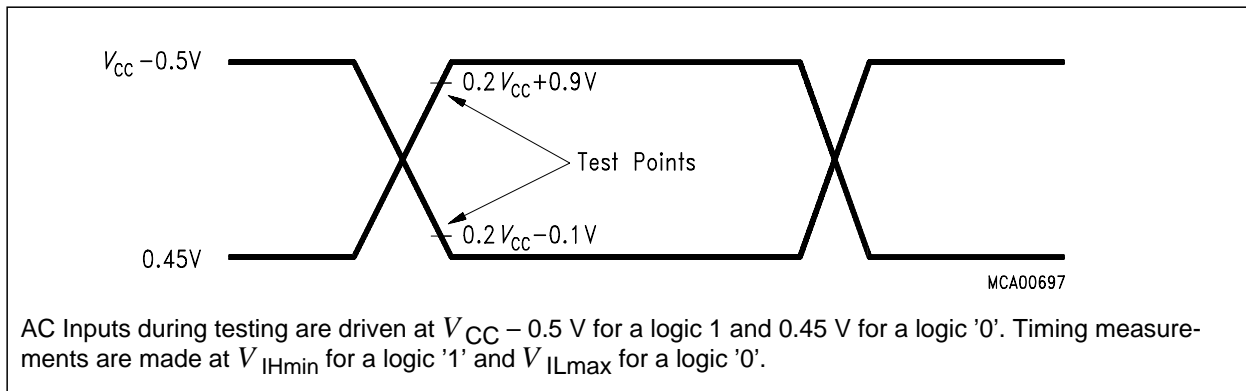

Input, Output Waveforms

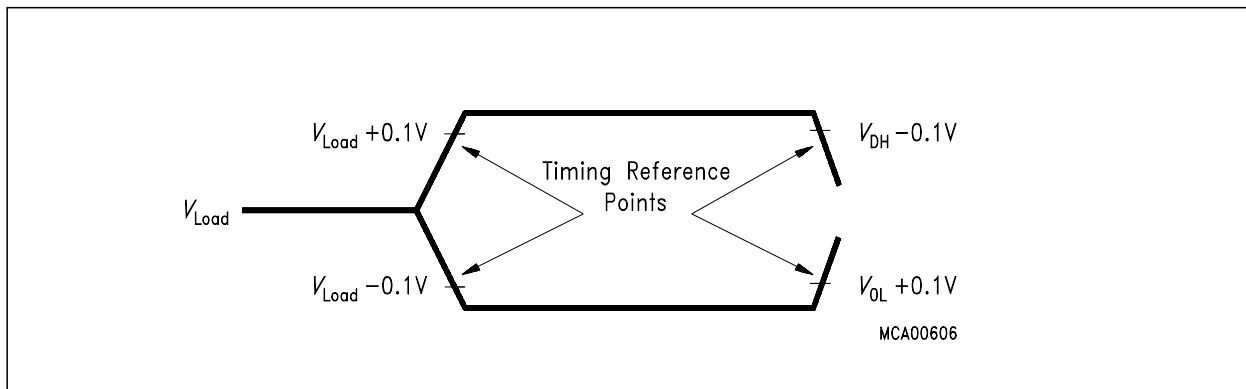

Float Waveforms