

FALC56

E1/T1/J1 Framer and Line
Interface Component for Long-
and Short-Haul Applications

PEB 2256 HT Version 1.2

PEB 2256 E Version 1.2

Wired
Communications



Never stop thinking.

Data Sheet

Revision History: **2002-08-27**

DS 3

Previous Version: DS 2

Page	Subjects (major changes since last revision)
479	P-LBGA-81-1 Package Outline

For questions on technology, delivery and prices please contact the Infineon Technologies Offices in Germany or the Infineon Technologies Companies and Representatives worldwide: see our webpage at <http://www.infineon.com>

ABM[®], ABM[®], ACE[®], AOP[®], ARCOFI[®], ASM[®], ASP[®], DigiTape[®], DuSLIC[®], EPIC[®], ELIC[®], FALC[®], GEMINAX[®], IDEC[®], INCA[®], IOM[®], IPAT[®]-2, ISAC[®], ITAC[®], IWE[®], IWORX[®], MUSAC[®], MuSLIC[®], OCTAT[®], OptiPort[®], POTSWIRE[®], QUAT[®], QuadFALC[®], SCOUT[®], SICOFI[®], SIDEC[®], SLICOFI[®], SMINT[®], SOCRATES[®], VINETIC[®], 10BaseV[®], 10BaseVX[®] are registered trademarks of Infineon Technologies AG.

10BaseS[™], EasyPort[™] are trademarks of Infineon Technologies AG.

Edition 2002-08-27

**Published by Infineon Technologies AG,
St.-Martin-Strasse 53,
D-81541 München, Germany**

**© Infineon Technologies AG 2002.
All Rights Reserved.**

Attention please!

The information herein is given to describe certain components and shall not be considered as warranted characteristics.

Terms of delivery and rights to technical change reserved.

We hereby disclaim any and all warranties, including but not limited to warranties of non-infringement, regarding circuits, descriptions and charts stated herein.

Infineon Technologies is an approved CECC manufacturer.

Information

For further information on technology, delivery terms and conditions and prices please contact your nearest Infineon Technologies Office in Germany or our Infineon Technologies Representatives worldwide.

Warnings

Due to technical requirements components may contain dangerous substances. For information on the types in question please contact your nearest Infineon Technologies Office.

Infineon Technologies Components may only be used in life-support devices or systems with the express written approval of Infineon Technologies, if a failure of such components can reasonably be expected to cause the failure of that life-support device or system, or to affect the safety or effectiveness of that device or system. Life support devices or systems are intended to be implanted in the human body, or to support and/or maintain and sustain and/or protect human life. If they fail, it is reasonable to assume that the health of the user or other persons may be endangered.

Table of Contents		Page
1	Introduction	18
1.1	Features	19
1.2	Logic Symbol	23
1.3	Typical Applications	24
2	Pin Descriptions	26
2.1	Pin Diagram P-MQFP-80-1	26
2.2	Pin Diagram P-LBGA-81-1	27
2.3	Pin Definitions and Functions	29
3	Functional Description E1/T1/J1	50
3.1	Functional Overview	50
3.2	Block Diagram	51
3.3	Functional Blocks	52
3.3.1	Microprocessor Interface	52
3.3.1.1	Mixed Byte/Word Access to the FIFOs	52
3.3.1.2	FIFO Structure	53
3.3.1.3	Interrupt Interface	55
3.3.2	Boundary Scan Interface	57
3.3.3	Master Clocking Unit	59
4	Functional Description E1	60
4.1	Receive Path in E1 Mode	60
4.1.1	Receive Line Interface	60
4.1.2	Receive Short and Long-Haul Interface	60
4.1.3	Receive Equalization Network (E1)	61
4.1.4	Receive Line Attenuation Indication (E1)	61
4.1.5	Receive Clock and Data Recovery (E1)	61
4.1.6	Receive Line Coding (E1)	62
4.1.7	Receive Line Monitoring Mode	63
4.1.8	Loss-of-Signal Detection (E1)	65
4.1.9	Receive Jitter Attenuator (E1)	66
4.1.10	Jitter Tolerance (E1)	69
4.1.11	Output Jitter (E1)	69
4.1.12	Framer/Synchronizer (E1)	70
4.1.13	Receive Elastic Buffer (E1)	70
4.1.14	Receive Signaling Controller (E1)	73
4.1.14.1	HDLC or LAPD access	73
4.1.14.2	Support of Signaling System #7	74
4.1.14.3	Sa-Bit Access (E1)	76
4.1.14.4	Channel Associated Signaling CAS (E1, serial mode)	76
4.1.14.5	Channel Associated Signaling CAS (E1, μ P access mode)	77
4.2	Framer Operating Modes (E1)	79
4.2.1	General	79

Table of Contents		Page
4.2.2	Doubleframe Format (E1)	80
4.2.2.1	Transmit Transparent Modes	80
4.2.2.2	Synchronization Procedure	81
4.2.2.3	A-Bit Access	82
4.2.2.4	Sa-Bit Access	82
4.2.3	CRC-Multiframe (E1)	83
4.2.3.1	Synchronization Procedure	84
4.2.3.2	Automatic Force Resynchronization (E1)	85
4.2.3.3	Floating Multiframe Alignment Window (E1)	85
4.2.3.4	CRC4 Performance Monitoring (E1)	85
4.2.3.5	Modified CRC4 Multiframe Alignment Algorithm (E1)	85
4.2.3.6	A-Bit Access (E1)	86
4.2.3.7	Sa-Bit Access (E1)	87
4.2.3.8	E-Bit Access (E1)	88
4.3	Additional Receive Framing Functions (E1)	90
4.3.1	Error Performance Monitoring and Alarm Handling	90
4.3.2	Auto Modes	91
4.3.3	Error Counter	92
4.3.4	Errored Second	92
4.3.5	One-Second Timer	92
4.3.6	In-Band Loop Generation and Detection	92
4.3.7	Time Slot 0 Transparent Mode	93
4.4	Transmit Path in E1 Mode	94
4.4.1	Transmitter (E1)	94
4.4.2	Transmit Line Interface (E1)	95
4.4.3	Transmit Jitter Attenuator (E1)	96
4.4.4	Transmit Elastic Buffer (E1)	97
4.4.5	Programmable Pulse Shaper (E1)	98
4.4.6	Transmit Line Monitor (E1)	98
4.4.7	Transmit Signaling Controller (E1)	99
4.4.7.1	HDLC or LAPD access	99
4.4.7.2	Support of Signaling System #7	100
4.4.7.3	Sa-Bit Access (E1)	100
4.4.7.4	Channel Associated Signaling CAS (E1, serial mode)	101
4.4.7.5	Channel Associated Signaling CAS (E1, μ P access mode)	101
4.5	System Interface in E1 Mode	102
4.5.1	Receive System Interface (E1)	105
4.5.1.1	Receive Offset Programming	106
4.5.2	Transmit System Interface (E1)	109
4.5.2.1	Transmit Offset Programming	111
4.5.3	Time Slot Assigner (E1)	113
4.6	Test Functions (E1)	114

Table of Contents		Page
4.6.1	Pseudo-Random Binary Sequence Generation and Monitor	114
4.6.2	Remote Loop	114
4.6.3	Payload Loop-Back	115
4.6.4	Local Loop	116
4.6.5	Single Channel Loop-Back	117
4.6.6	Alarm Simulation (E1)	118
4.6.7	Single Bit Defect Insertion	118
5	Functional Description T1/J1	119
5.1	Receive Path in T1/J1 Mode	119
5.1.1	Receive Line Interface (T1/J1)	119
5.1.2	Receive Short and Long-Haul Interface (T1/J1)	119
5.1.3	Receive Equalization Network (T1/J1)	120
5.1.4	Receive Line Attenuation Indication (T1/J1)	120
5.1.5	Receive Clock and Data Recovery (T1/J1)	120
5.1.6	Receive Line Coding (T1/J1)	121
5.1.7	Receive Line Monitoring Mode	123
5.1.8	Loss-of-Signal Detection (T1/J1)	124
5.1.9	Receive Jitter Attenuator (T1/J1)	125
5.1.10	Jitter Tolerance (T1/J1)	128
5.1.11	Output Jitter (T1/J1)	129
5.1.12	Framer/Synchronizer (T1/J1)	129
5.1.13	Receive Elastic Buffer (T1/J1)	129
5.1.14	Receive Signaling Controller (T1/J1)	134
5.1.14.1	HDLC or LAPD access	134
5.1.14.2	Support of Signaling System #7	135
5.1.14.3	CAS Bit-Robbing (T1/J1, serial mode)	137
5.1.14.4	CAS Bit-Robbing (T1/J1, μ P access mode)	137
5.1.14.5	Bit Oriented Messages in ESF-DL Channel (T1/J1)	137
5.1.14.6	4 kbit/s Data Link Access in F72 Format (T1/J1)	138
5.2	Framer Operating Modes (T1/J1)	139
5.2.1	General	139
5.2.2	General Aspects of Synchronization	139
5.2.3	Addition for F12 and F72 Format	140
5.2.4	4-Frame Multiframe (F4 Format, T1/J1)	142
5.2.4.1	Synchronization Procedure	142
5.2.5	12-Frame Multiframe (D4 or SF Format, T1/J1)	143
5.2.5.1	Synchronization Procedure	143
5.2.6	Extended Superframe (F24 or ESF Format, T1/J1)	144
5.2.6.1	Synchronization Procedures	145
5.2.6.2	Remote Alarm (yellow alarm) Generation/Detection	146
5.2.6.3	CRC6 Generation and Checking (T1/J1)	146
5.2.7	72-Frame Multiframe (SLC96 Format, T1/J1)	146

Table of Contents		Page
5.2.7.1	Synchronization Procedure	147
5.2.8	Summary of Frame Conditions (T1/J1)	149
5.3	Additional Receive Framer Functions (T1/J1)	150
5.3.1	Error Performance Monitoring and Alarm Handling	150
5.3.2	Auto Modes	151
5.3.3	Error Counter	152
5.3.4	Errored Second	152
5.3.5	One-Second Timer	152
5.3.6	Clear Channel Capability	153
5.3.7	In-Band Loop Generation and Detection	153
5.3.8	Transparent Mode	153
5.3.9	Pulse-Density Detection	153
5.4	Transmit Path in T1/J1 Mode	154
5.4.1	Transmitter (T1/J1)	154
5.4.2	Transmit Line Interface (T1/J1)	154
5.4.3	Transmit Jitter Attenuator (T1/J1)	155
5.4.4	Transmit Elastic Buffer (T1/J1)	157
5.4.5	Programmable Pulse Shaper and Line Build-Out (T1/J1)	159
5.4.6	Transmit Line Monitor (T1/J1)	160
5.4.7	Transmit Signaling Controller (T1/J1)	160
5.4.7.1	HDLC or LAPD access	160
5.4.7.2	Support of Signaling System #7	161
5.4.7.3	CAS Bit-Robbing (T1/J1, serial mode)	161
5.4.7.4	CAS Bit-Robbing (T1/J1, μ P access mode)	162
5.4.7.5	Data Link Access in ESF/F24 and F72 Format (T1/J1)	162
5.4.7.6	Periodical Performance Report in ESF Format (T1/J1)	162
5.5	System Interface in T1/J1 Mode	165
5.5.1	Receive System Interface (T1/J1)	167
5.5.1.1	Receive Offset Programming	168
5.5.2	Transmit System Interface (T1/J1)	172
5.5.2.1	Transmit Offset Programming	178
5.5.3	Time Slot Assigner (T1/J1)	180
5.6	Test Functions (T1/J1)	182
5.6.1	Pseudo-Random Binary Sequence Generation and Monitor	182
5.6.2	Remote Loop	182
5.6.3	Payload Loop-Back	183
5.6.4	Local Loop	184
5.6.5	Single Channel Loop-Back (loop-back of time slots)	185
5.6.6	Alarm Simulation (T1/J1)	186
5.6.7	Single Bit Defect Insertion	186
5.7	J1-Feature Overview	187
6	Operational Description E1	188

Table of Contents		Page
6.1	Operational Overview E1	188
6.2	Device Reset E1	188
6.3	Device Initialization in E1 Mode	188
7	Operational Description T1/J1	194
7.1	Operational Overview T1/J1	194
7.2	Device Reset T1/J1	194
7.3	Device Initialization in T1/J1 Mode	194
8	Signaling Controller Operating Modes	201
8.1	HDLC Mode	201
8.1.1	Non-Auto Mode	201
8.1.2	Transparent Mode 1	202
8.1.3	Transparent Mode 0	202
8.1.4	SS7 Support	202
8.1.5	Receive Data Flow	202
8.1.6	Transmit Data Flow	204
8.2	Extended Transparent Mode	204
8.3	Signaling Controller Functions	205
8.3.1	Transparent Transmission and Reception	205
8.3.2	CRC on/off Features	205
8.3.3	Receive Address Pushed to RFIFO	206
8.3.4	HDLC Data Transmission	206
8.3.5	HDLC Data Reception	208
8.3.6	Sa-bit Access (E1)	208
8.3.7	Bit Oriented Message Mode (T1/J1)	209
8.3.8	Data Link Access in ESF/F72 Format (T1/J1)	211
9	E1 Registers	213
9.1	E1 Control Register Addresses	213
9.2	Detailed Description of E1 Control Registers	217
9.3	E1 Status Register Addresses	286
9.4	Detailed Description of E1 Status Registers	289
10	T1/J1 Registers	330
10.1	T1/J1 Control Register Addresses	330
10.2	Detailed Description of T1/J1 Control Registers	334
10.3	T1/J1 Status Register Addresses	407
10.4	Detailed Description of T1/J1 Status Registers	409
11	Electrical Characteristics	446
11.1	Absolute Maximum Ratings	446
11.2	Operating Range	446
11.3	DC Characteristics	447

Table of Contents		Page
11.4	AC Characteristics	450
11.4.1	Master Clock Timing	450
11.4.2	JTAG Boundary Scan Interface	451
11.4.3	Reset	452
11.4.4	Microprocessor Interface	453
11.4.4.1	Intel Bus Interface Mode	453
11.4.4.2	Motorola Bus Interface Mode	456
11.4.5	Line Interface	458
11.4.6	System Interface	460
11.4.7	Pulse Templates - Transmitter	472
11.4.7.1	Pulse Template E1	472
11.4.7.2	Pulse Template T1	473
11.5	Capacitances	474
11.6	Package Characteristics	474
11.7	Test Configuration	475
11.7.1	AC Tests	475
11.7.2	Power Supply Test	476
12	Package Outlines	478
13	Appendix	480
13.1	Protection Circuitry	480
13.2	Application Notes	481
13.3	Software Support	481
14	Glossary	484

List of Figures		Page
Figure 1	Logic Symbol	23
Figure 2	Multiple E1/T1/J1 Link over Frame Relay	24
Figure 3	8-Channel E1/T1/J1-Interface to the ATM Layer	25
Figure 4	Pin Configuration P-MQFP-80-1	26
Figure 5	Pin Configuration P-LBGA-81-1 (bottom view)	27
Figure 6	Pin Configuration P-LBGA-81-1 (top view)	28
Figure 7	Block Diagram	51
Figure 8	FIFO Word Access (Intel Mode)	54
Figure 9	FIFO Word Access (Motorola Mode)	54
Figure 10	Interrupt Status Registers	55
Figure 11	Block Diagram of Test Access Port and Boundary Scan	57
Figure 12	Flexible Master Clock Unit	59
Figure 13	Receive Clock System (E1)	60
Figure 14	Receiver Configuration (E1)	63
Figure 15	Receive Line Monitoring	64
Figure 16	Protection Switching Application	65
Figure 17	Jitter Attenuation Performance (E1)	68
Figure 18	Jitter Tolerance (E1)	69
Figure 19	The Receive Elastic Buffer as Circularly Organized Memory	72
Figure 20	Automatic Handling of Errored Signaling Units	75
Figure 21	2.048 MHz Receive Signaling Highway (E1)	77
Figure 22	CRC4 Multiframe Alignment Recovery Algorithms (E1)	89
Figure 23	Transmitter Configuration (E1)	95
Figure 24	Transmit Clock System (E1)	97
Figure 25	Transmit Line Monitor Configuration (E1)	99
Figure 26	2.048 MHz Transmit Signaling Highway (E1)	101
Figure 27	System Interface (E1)	104
Figure 28	Receive System Interface Clocking (E1)	105
Figure 29	$\overline{\text{SYPR}}$ Offset Programming (2.048 Mbit/s, 2.048 MHz)	107
Figure 30	$\overline{\text{SYPR}}$ Offset Programming (8.192 Mbit/s, 8.192 MHz)	107
Figure 31	RFM Offset Programming (2.048 Mbit/s, 2.048 MHz)	108
Figure 32	RFM Offset Programming (8.192 Mbit/s, 8.192 MHz)	108
Figure 33	Transmit System Interface Clocking: 2.048 MHz (E1)	109
Figure 34	Transmit System Interface Clocking: 8.192 MHz/4.096 Mbit/s (E1)	110
Figure 35	$\overline{\text{SYPX}}$ Offset Programming (2.048 Mbit/s, 2.048 MHz)	112
Figure 36	$\overline{\text{SYPX}}$ Offset Programming (8.192 Mbit/s, 8.192 MHz)	112
Figure 37	Remote Loop (E1)	114
Figure 38	Payload Loop (E1)	115
Figure 39	Local Loop (E1)	116
Figure 40	Single Channel Loop-Back (E1)	117
Figure 41	Receive Clock System (T1/J1)	119
Figure 42	Receiver Configuration (T1/J1)	122

List of Figures		Page
Figure 43	Receive Line Monitoring	123
Figure 44	Protection Switching Application	124
Figure 45	Jitter Attenuation Performance (T1/J1)	127
Figure 46	Jitter Tolerance (T1/J1)	128
Figure 47	The Receive Elastic Buffer as Circularly Organized Memory	133
Figure 48	Automatic Handling of Errored Signaling Units	136
Figure 49	Influences on Synchronization Status (T1/J1)	141
Figure 50	Transmitter Configuration (T1/J1)	155
Figure 51	Clocking in Remote Loop Configuration (T1/J1)	156
Figure 52	Transmit Clock System (T1/J1)	157
Figure 53	Transmit Line Monitor Configuration (T1/J1)	160
Figure 54	System Interface (T1/J1)	166
Figure 55	Receive System Interface Clocking (T1/J1)	167
Figure 56	$\overline{\text{SYPR}}$ Offset Programming (1.544 Mbit/s, 1.544 MHz)	169
Figure 57	$\overline{\text{SYPR}}$ Offset Programming (6.176 Mbit/s, 6.176 MHz)	169
Figure 58	RFM Offset Programming (1.544 Mbit/s, 1.544 MHz)	170
Figure 59	RFM Offset Programming (6.176 Mbit/s, 6.176 MHz)	170
Figure 60	2.048 MHz Receive Signaling Highway (T1/J1)	171
Figure 61	Receive FS/DL-Bits in Time Slot 0 on RDO (T1/J1)	171
Figure 62	1.544 MHz Receive Signaling Highway (T1/J1)	172
Figure 63	Transmit System Clocking: 1.544 MHz (T1/J1)	173
Figure 64	Transmit System Clocking: 8.192 MHz/4.096 Mbit/s (T1/J1)	174
Figure 65	2.048 MHz Transmit Signaling Clocking (T1/J1)	175
Figure 66	1.544 MHz Transmit Signaling Highway (T1/J1)	175
Figure 67	Signaling Marker for CAS/CAS-CC Applications (T1/J1)	176
Figure 68	Signaling Marker for CAS-BR Applications (T1/J1)	177
Figure 69	Transmit FS/DL Bits on XDI (T1/J1)	178
Figure 70	$\overline{\text{SYPX}}$ Offset Programming (1.544 Mbit/s, 1.544 MHz)	179
Figure 71	$\overline{\text{SYPX}}$ Offset Programming (6.176 Mbit/s, 6.176 MHz)	179
Figure 72	Remote Loop (T1/J1)	182
Figure 73	Payload Loop (T1/J1)	183
Figure 74	Local Loop (T1/J1)	184
Figure 75	Channel Loop-Back (T1/J1)	185
Figure 76	HDLC Receive Data Flow	203
Figure 77	HDLC Transmit Data Flow	204
Figure 78	Interrupt Driven Data Transmission (flow diagram)	207
Figure 79	Interrupt Driven Transmission Example	207
Figure 80	Interrupt Driven Reception Sequence Example	208
Figure 81	MCLK Timing	450
Figure 82	JTAG Boundary Scan Timing	451
Figure 83	Reset Timing	452
Figure 84	Intel Non-Multiplexed Address Timing	453

List of Figures	Page
Figure 85 Intel Multiplexed Address Timing	453
Figure 86 Intel Read Cycle Timing	454
Figure 87 Intel Write Cycle Timing	454
Figure 88 Motorola Read Cycle Timing	456
Figure 89 Motorola Write Cycle Timing	456
Figure 90 Digital Line Interface Receive Timing	458
Figure 91 Digital Line Interface Transmit Timing	458
Figure 92 RCLK, RFSP Output Timing	460
Figure 93 SCLKR/SCLKX Input Timing	461
Figure 94 System Interface Marker Timing (Receive)	462
Figure 95 SYPR, SYPX Timing	463
Figure 96 System Interface Marker Timing (Transmit).	465
Figure 97 XDI, XSIG Timing.	466
Figure 98 TCLK Input Timing.	467
Figure 99 XCLK Timing	468
Figure 100 SEC Timing	469
Figure 101 FSC Timing	470
Figure 102 SYNC Timing	471
Figure 103 E1 Pulse Shape at Transmitter Output	472
Figure 104 T1 Pulse Shape at the Cross Connect Point	473
Figure 105 Thermal Behavior of Package	474
Figure 106 Input/Output Waveforms for AC Testing	475
Figure 107 Device Configuration for Power Supply Testing	476
Figure 108 Protection Circuitry Examples	480
Figure 109 Master Clock Frequency Calculator.	482
Figure 110 External Line Frontend Calculator	483

List of Tables		Page
Table 1	Pin Definitions - Microprocessor Interface	29
Table 2	Pin Definitions - Line Interface	32
Table 3	Pin Definitions - Clock Generation	36
Table 4	Pin Definitions - System Interface	39
Table 5	Pin Definitions - Miscellaneous	48
Table 6	Data Bus Access (16-Bit Intel Mode)	52
Table 7	Data Bus Access (16-Bit Motorola Mode)	52
Table 8	Selectable Bus and Microprocessor Interface Configuration	53
Table 9	TAP Controller Instruction Codes	58
Table 10	RCLK Output Selection (E1)	62
Table 11	Recommended Receiver Configuration Values (E1)	63
Table 12	External Component Recommendations (Monitoring)	64
Table 13	System Clocking (E1)	67
Table 14	Output Jitter (E1)	69
Table 15	Receive Buffer Operating Modes (E1)	71
Table 16	Allocation of Bits 1 to 8 of Time Slot 0 (E1)	80
Table 17	Transmit Transparent Mode (Doubleframe E1)	81
Table 18	CRC-Multiframe Structure (E1)	83
Table 19	Transmit Transparent Mode (CRC Multiframe E1)	84
Table 20	Summary of Alarm Detection and Release (E1)	90
Table 21	Recommended Transmitter Configuration Values (E1)	95
Table 22	Transmit Buffer Operating Modes (E1)	98
Table 23	System Clocking and Data Rates (E1)	102
Table 24	Time Slot Assigner HDLC Channel 1 (E1)	113
Table 25	RCLK Output Selection (T1/J1)	121
Table 26	Recommended Receiver Configuration Values (T1/J1)	122
Table 27	External Component Recommendations (Monitoring)	123
Table 28	System Clocking (T1/J1)	126
Table 29	Output Jitter (T1/J1)	129
Table 30	Channel Translation Modes (DS1/J1)	131
Table 31	Receive Buffer Operation Modes (T1/J1)	132
Table 32	Resynchronization Timing (T1/J1)	140
Table 33	4-Frame Multiframe Structure (T1/J1)	142
Table 34	12-Frame Multiframe Structure (T1/J1)	143
Table 35	Extended Superframe Structure (F24, ESF; T1/J1)	144
Table 36	72-Frame Multiframe Structure (T1/J1)	148
Table 37	Summary Frame Recover/Out of Frame Conditions (T1/J1)	149
Table 38	Summary of Alarm Detection and Release (T1/J1)	150
Table 39	Recommended Transmitter Configuration Values (T1/J1)	155
Table 40	Transmit Buffer Operating Modes (T1/J1)	159
Table 41	Pulse Shaper Programming (T1/J1)	159
Table 42	Structure of Periodical Performance Report (T1/J1)	163

List of Tables	Page
Table 43	Bit Functions in Periodical Performance Report 164
Table 44	System Clocking and Data Rates (T1/J1) 165
Table 45	Time Slot Assigner HDLC Channel 1 (T1/J1) 180
Table 46	Initial Values after Reset (E1) 188
Table 47	Initialization Parameters (E1) 190
Table 48	Line Interface Initialization (E1) 191
Table 49	Framer Initialization (E1) 192
Table 50	HDLC Controller Initialization (E1) 192
Table 51	CAS-CC Initialization (E1) 193
Table 52	Initial Values after reset and FMR1.PMOD = 1 (T1/J1) 194
Table 53	Initialization Parameters (T1/J1) 197
Table 54	Line Interface Initialization (T1/J1) 198
Table 55	Framer Initialization (T1/J1) 199
Table 56	HDLC Controller Initialization (T1/J1) 200
Table 57	Initialization of the CAS-BR Controller (T1/J1) 200
Table 58	E1 Control Register Address Arrangement 213
Table 59	Transmit CAS Registers (E1) 263
Table 60	Clock Mode Register Settings for E1 or T1/J1 280
Table 61	E1 Status Register Address Arrangement 286
Table 62	Receive CAS Registers (E1) 322
Table 63	T1/J1 Control Register Address Arrangement 330
Table 64	Pulse Shaper Programming (T1/J1) 361
Table 65	Transmit Signaling Registers (T1/J1) 383
Table 66	Clock Mode Register Settings for E1 or T1/J1 401
Table 67	T1/J1 Status Register Address Arrangement 407
Table 68	Alarm Simulation States 415
Table 69	Receive Signaling Registers (T1/J1) 438
Table 70	MCLK Timing Parameters 450
Table 71	JTAG Boundary Scan Timing Parameter Values 451
Table 72	Reset Timing Parameter Values 452
Table 73	Intel Bus Interface Timing Parameter Values 455
Table 74	Motorola Bus Interface Timing Parameter Values 457
Table 75	Digital Line Interface Parameter Values 459
Table 76	RCLK, RFSP Timing Parameter Values 460
Table 77	SCLKR/SCLKX Timing Parameter Values 461
Table 78	System Interface Marker Timing Parameter Values 462
Table 79	SYPR/SYPX Timing Parameter Values 463
Table 80	System Interface Marker Timing Parameter Values 465
Table 81	XDI, XSIG Timing Parameter Values 466
Table 82	TCLK Timing Parameter Values 467
Table 83	XCLK Timing Parameter values 468
Table 84	SEC Timing Parameter Values 469

List of Tables		Page
Table 85	FSC Timing Parameter Values	470
Table 86	SYNC Timing Parameter Values	471
Table 87	T1 Pulse Template at Cross Connect Point (T1.102)	473
Table 88	Package Characteristic Values	474
Table 89	AC Test Conditions	475
Table 90	Power Supply Test Conditions E1	476
Table 91	Power Supply Test Conditions T1/J1	477

Preface

The FALC56 framer and line interface component is designed to fulfill all required interfacing between an analog E1/T1/J1 line and the digital PCM system highway/H.100 bus.

The digital functions as well as the analog characteristics are configured via a flexible microprocessor interface.

Organization of this Document

This Data Sheet is organized as follows:

- **Chapter 1, Introduction**
Gives a general description of the product and its family, lists the key features, and presents some typical applications.
- **Chapter 2, Pin Descriptions**
Lists pin locations with associated signals, categorizes signals according to function, and describes signals.
- **Chapter 3 to Chapter 5, Functional Description E1/T1/J1**
These chapters describe the functional blocks and principle operation modes, organized into separate sections for E1 and T1/J1 operation
- **Chapter 6 and Chapter 7, Operational Description E1/T1/J1**
Shows the operation modes and how they are to be initialized (separately for E1 and T1/J1).
- **Chapter 8, Signaling Controller Operating Modes**
Describes signaling controller functions for both E1 and T1/J1 operation.
- **Chapter 9 and Chapter 10, E1 Registers and T1/J1 Registers**
Gives a detailed description of all implemented registers and how to use them in different applications/configurations.
- **Chapter 11, Electrical Characteristics**
Specifies maximum ratings, DC and AC characteristics.
- **Chapter 12, Package Outlines**
Shows the mechanical values of the device packages.
- **Chapter 13, Appendix**
Gives an example for overvoltage protection and information about application notes and other support.
- **Chapter 14, Glossary**
- **Index**

Related Documentation

A detailed description of changes from version 1.1 to 1.2 is given in the "PEB 2256 Version 1.2 Delta Sheet".

This document refers to the following international standards (in alphabetical/numerical order):

ANSI/EIA-656	ITU-T G.705
ANSI T1.102	ITU-T G.706
ANSI T1.403	ITU-T G.732
AT&T PUB 43802	ITU-T G.735
AT&T PUB 54016	ITU-T G.736
AT&T PUB 62411	ITU-T G.737
ESD Ass. Standard EOS/ESD-5.1-1993	ITU-T G.738
ETSI ETS 300 011	ITU-T G.739
ETIS ETS 300 166	ITU-T G.823
ETSI ETS 300 233	ITU-T G.824
ETSI ETS 300 324	ITU-T G.962
ETSI ETS 300 347	ITU-T G.963
ETSI TBR12	ITU-T G.964
ETSI TBR13	ITU-T I.431
FCC Part68	ITU-Q.703
GR-253-CORE	JT-G703
GR-499-CORE	JT-G704
GR-1089-CORE	JT-G706
H.100	JT-I431
H-MVIP	MIL-Std. 883D
IEEE 1149.1	TR-TSY-000009
ITU-T G.703	UL 1459
ITU-T G.704	

Your Comments

We welcome your comments on this document. We are continuously trying improving our documentation. Please send your remarks and suggestions by e-mail to com.docu_comments@infineon.com

Please provide in the subject of your e-mail:

device name (FALC56), device number (PEB 2256 HT), device version (Version 1.2),

and in the body of your e-mail:

document type (Data Sheet), issue date (2002-08-27) and document revision number (DS 3).

1 Introduction

The FALC56 framer and line interface component is designed to fulfill all required interfacing between analog E1/T1/J1 lines and the digital PCM system highway, H.100/H.110 or H-MVIP bus for world market telecommunication systems.

Due to its multitude of implemented functions, it fits to a wide range of networking applications and fulfills the according international standards. An integrated signaling controller including Signaling System #7 (SS7) support reduces software overhead.

Crystal-less jitter attenuation with only one master clock source reduces the amount of required external components.

Equipped with a flexible microprocessor interface, it connects to any control processor environment. A standard boundary scan interface is provided to support board level testing. Flat pack or BGA device packaging, minimum number of external components and low power consumption lead to reduced overall system costs.

Other members of the FALC[®] family are the FALC[®]54 for short-haul applications, the FALC[®]-LH for long-haul and short-haul applications as well as the QuadFALC supporting four channels on a single chip.

E1/T1/J1 Framer and Line Interface Component for Long- and Short-Haul Applications FALC56

PEB 2256 HT

Version 1.2

1.1 Features

Line Interface

- High-density, generic interface for all E1/T1/J1 applications
- Analog receive and transmit circuits for long-haul and short-haul applications
- E1 or T1/J1 mode selectable
- Data and clock recovery using an integrated digital phase-locked loop
- Maximum line attenuation up to -43 dB at 1024 kHz (E1) and up to -36 dB at 772 kHz (T1/J1)
- Programmable transmit pulse shapes for E1 and T1/J1 pulse masks
- Programmable line build-out for CSU signals according to ANSI T1. 403 and FCC68: 0dB, -7.5dB, -15dB, -22.5 dB (T1/J1)
- Low transmitter output impedances for high transmit return loss
- Tristate function of the analog transmit line outputs
- Transmit line monitor protecting the device from damage
- Receive line monitor mode
- Jitter specifications of ITU-T I.431, G.703, G.736 (E1), G.823 (E1) and AT&T TR62411 (T1/J1) are met
- Crystal-less wander and jitter attenuation/compensation
- Common master clock reference for E1 and T1/J1 (any frequency within 1.02 and 20 MHz)
- Power-down function

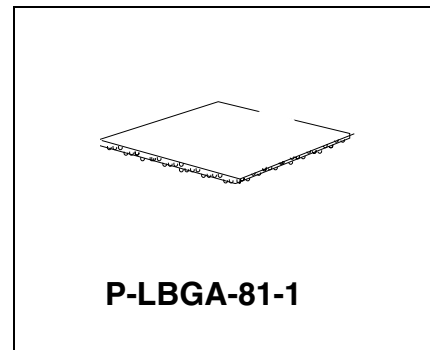
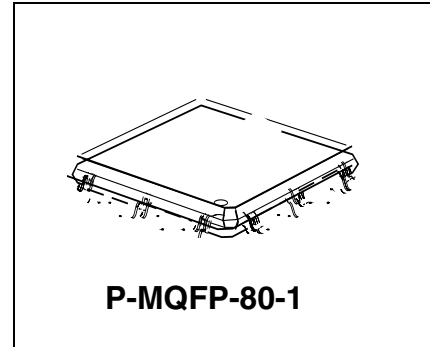

Type	Package
PEB 2256 HT	P-MQFP-80-1
PEB 2256 E	P-LBGA-81-1

- Support of automatic protection switching
- Dual-rail or single-rail digital inputs and outputs
- Unipolar NRZ or CMI for interfacing fiber-optical transmission routes
- Selectable line codes (E1: HDB3, AMI/T1: B8ZS, AMI with ZCS)
- Loss-of-signal indication with programmable thresholds according to ITU-T G.775, ETS300233 (E1) and ANSI T1.403 (T1/J1)
- Optional data stream muting upon LOS detection
- Programmable receive slicer threshold
- Clock generator for jitter-free system/transmit clocks per channel
- Local loop and remote loop for diagnostic purposes
- Low power device, single power supply: 3.3 V with 5 V tolerant digital inputs

Frame Aligner

- Frame alignment/synthesis for 2048 kbit/s according to ITU-T G.704 (E1) and for 1544 kbit/s according to ITU-T G.704 and JT G.704 (T1/J1)
- Programmable frame formats:
 - E1: Doubleframe, CRC multiframe (E1)
 - T1: 4-frame multiframe (F4,FT), 12-frame multiframe (F12, D3/4), extended superframe (F24, ESF), remote switch mode (F72, SLC96)
- Selectable conditions for recover/loss of frame alignment
- CRC4 to non-CRC4 interworking according to ITU-T G. 706 Annex B (E1)
- Error checking via CRC4 procedures according to ITU-T G. 706 (E1)
- Error checking via CRC6 procedures according to ITU-T G. 706 and JT G.706 (T1/J1)
- Performs synchronization in ESF format according to NTT requirements (J1)
- Alarm and performance monitoring per second
 - 16 bit counter for CRC-errors, framing errors, code violations, error monitoring via E-bit and SA6-bit (E1), errored blocks, PRBS bit errors
- Insertion and extraction of alarm indication signals (AIS, remote/yellow alarm,...)
- Remote alarm generation/checking according to ITU JT-G.704 in ESF-format (J1)
- IDLE code insertion for selectable channels
- Single-bit defect insertion
- Flexible system clock frequency for receiver and transmitter
- Supports programmable system data rates with independent receive/transmit shifts:
 - E1: 2.048, 4.096, 8.192 and 16.384 Mbit/s (according to H.100/H.110 bus)
 - T1/J1: 2.048, 4.096, 8.192, 16.384 Mbit/s and 1.544, 3.088, 6.176, 12.352 Mbit/s
- Elastic store for receive and transmit route clock wander and jitter compensation; controlled slip capability and slip indication
- Programmable elastic buffer size: 2 frames/1 frame/short buffer/bypass
- Provides different time slot mapping modes
- Supports fractional E1 or T1/J1 access
- Flexible transparent modes
- Programmable in-band loop code detection and generation (TR62411)

- Channel loop back, line loop back or payload loop back capabilities (TR54016)
- Pseudo-random binary sequence generator and monitor (framed or unframed)
- Clear channel capabilities (T1/J1)
- Loop-timed mode

Signaling Controller

- Three HDLC controllers
Bit stuffing, CRC check and generation, flag generation, flag and address recognition, handling of bit oriented functions
- Supports signaling system #7
delimitation, alignment and error detection according to ITU-Q.703
processing of fill in signaling units, processing of errored signaling units
- CAS/CAS-BR controller with last look capability, enhanced CAS-register access and freeze signaling indication
- DL-channel protocol for ESF format according to ANSI T1.403 specification or according to AT&T TR54016 (T1/J1)
- DL-bit access for F72 (SLC96) format (T1/J1)
- Generates periodical performance report according to ANSI T1. 403
- Provides access to serial signaling data streams
- Multiframe synchronization and synthesis according to ITU-T G.732
- Alarm insertion and detection (AIS and LOS in time slot 16)
- Transparent mode
- FIFO buffers (64 bytes deep) for efficient transfer of data packets
- Time slot assignment
Any combination of time slots selectable for data transfer independent of signaling mode (useful for fractional T1/J1 applications)
- Time-slot 0 S_a 8...4-bit handling via FIFOs (E1)
- HDLC access to any S_a -bit combination (E1)

Microprocessor Interface

- 8/16-bit microprocessor bus interface (Intel or Motorola type)
- All registers directly accessible (byte or word access)
- Multiplexed and non-multiplexed address bus operations
- Hard/software reset options
- Extended interrupt capabilities
- One-second timer (internal or external timing reference)

General

- Boundary scan standard IEEE 1149.1
- P-LBGA-81-1 package; body size 10 mm × 10 mm; ball pitch 1.0 mm or
- P-MQFP-80-1 package; body size 14 mm × 14 mm; lead pitch 0.5 mm
- Temperature range from -40 to +85 °C
- 3.3 V power supply, digital inputs 5V tolerant
- Typical power consumption 250 mW

Applications

- Wireless basestations
- E1/T1/J1 ATM gateways, multiplexer
- E1/T1/J1 **Channel & Data Service Units** (CSU, DSU)
- E1/T1/J1 Internet access equipment
- LAN/WAN router
- ISDN PRI, PABX
- **Digital Access Crossconnect Systems** (DACS)
- SONET/SDH add/drop multiplexer

1.2 Logic Symbol

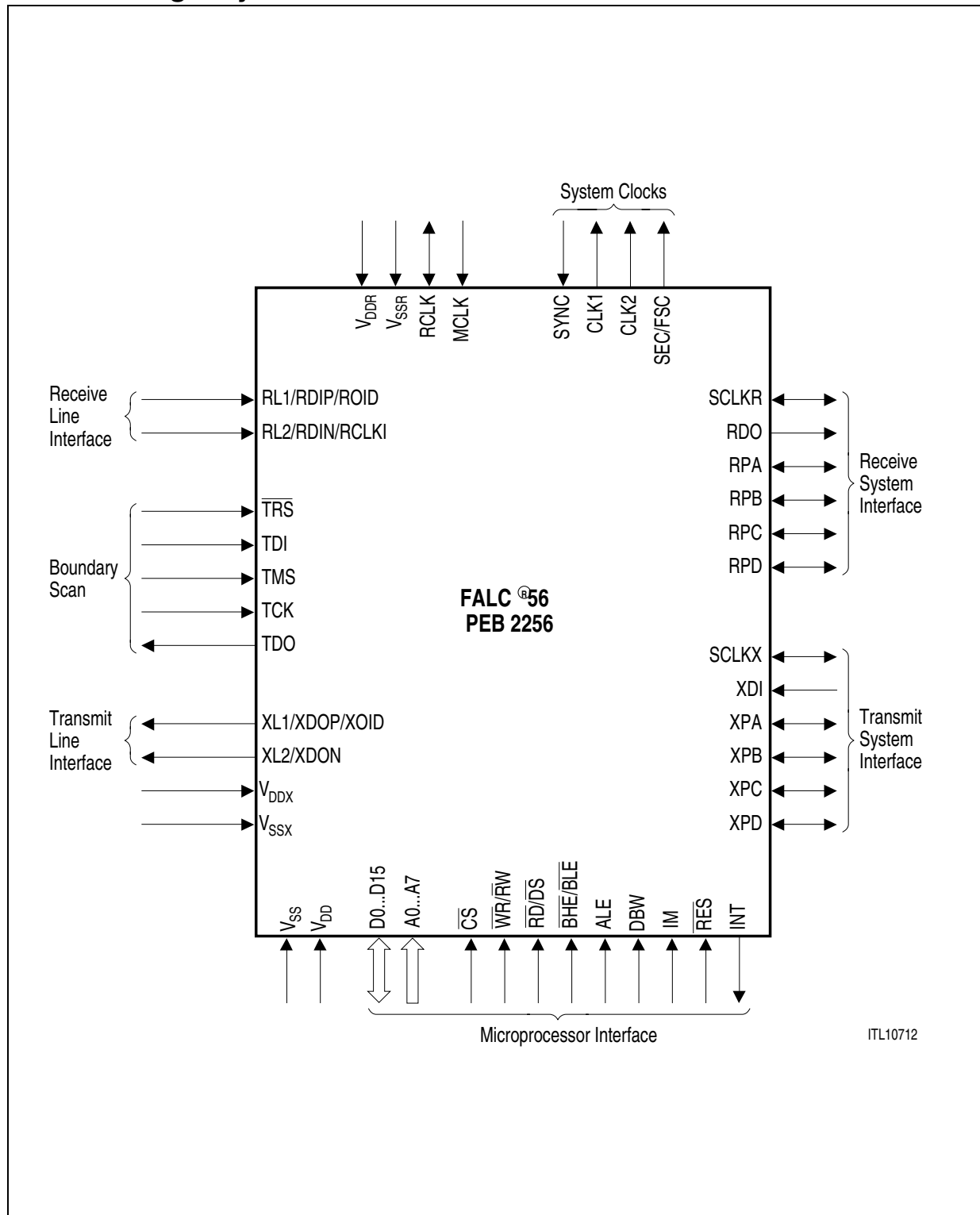

Figure 1 Logic Symbol

1.3 Typical Applications

The figures show a multiple link application for Frame Relay applications using the FALC[®]56 together with the 128-channel HDLC controller M128X and the Memory Timeswitch MTSL as well as an 8-channel interface to the ATM layer.

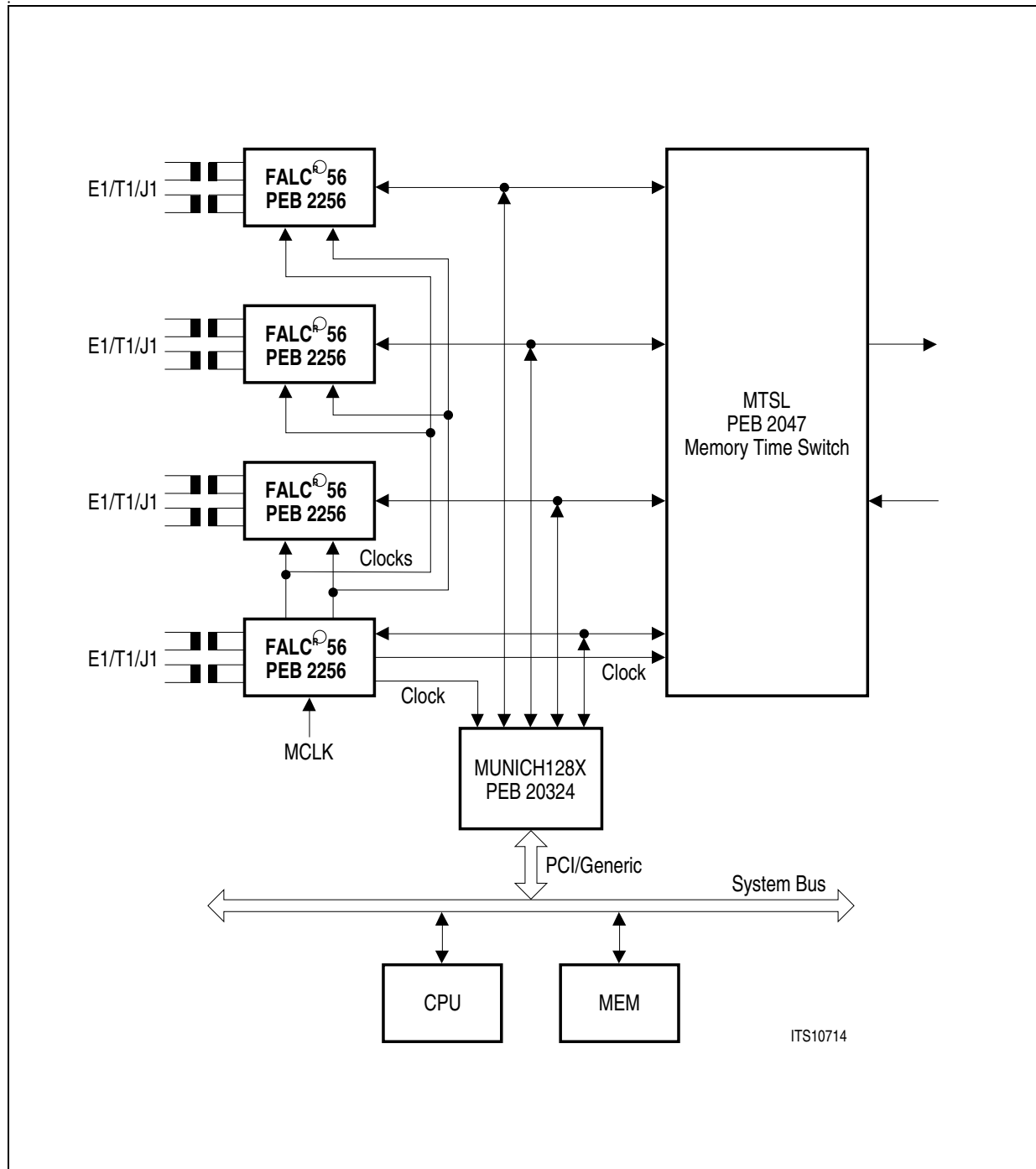

Figure 2 Multiple E1/T1/J1 Link over Frame Relay

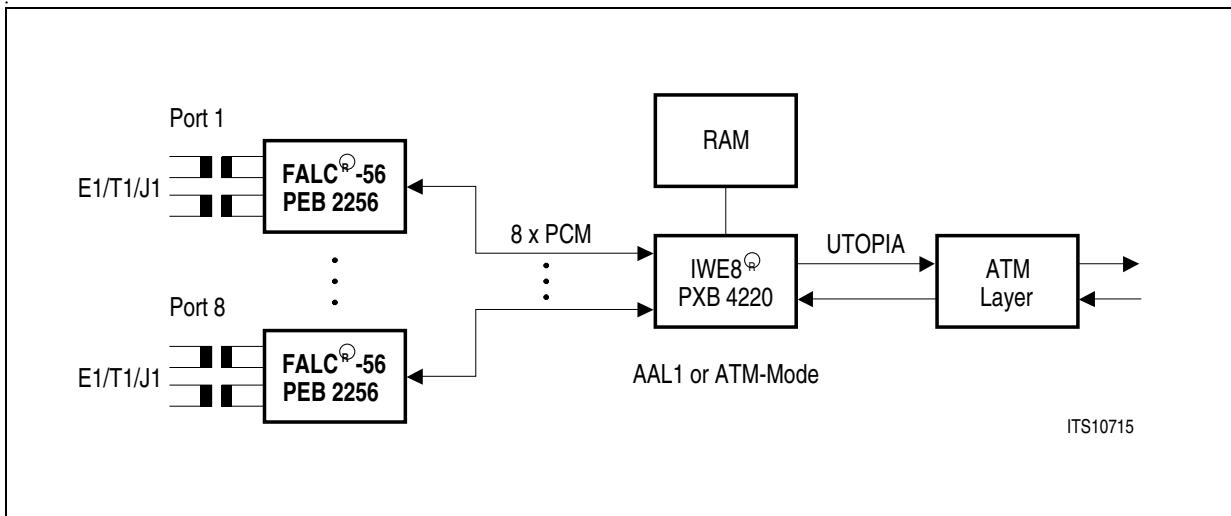

Figure 3 8-Channel E1/T1/J1-Interface to the ATM Layer

2 Pin Descriptions

2.1 Pin Diagram P-MQFP-80-1

(top view)

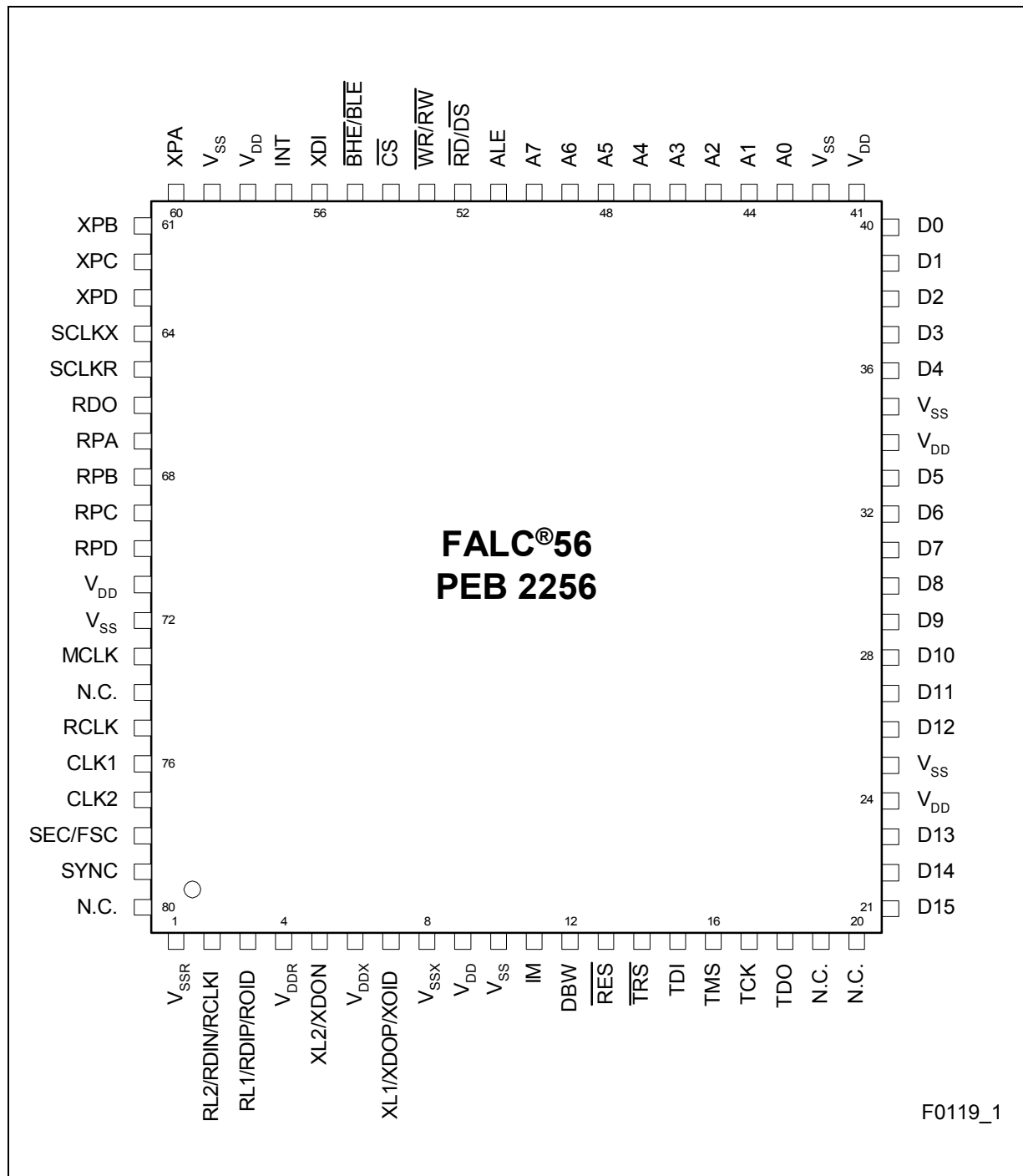

Figure 4 Pin Configuration P-MQFP-80-1

2.2 Pin Diagram P-LBGA-81-1

	9	8	7	6	5	4	3	2	1
A	XPB	XPC	SCLKR	RPB	VDD	NC	RCLK	SYNC	VSSR
B	VSS	XPA	XPB	RDO	RPC	CLK1	SEC/ FSC	NC	RL2/ RDIN
C	$\overline{\text{BHE/}}/\overline{\text{BLE}}$	VDD	INT	SCLKX	VSS	MCLK	CLK2	RL1/ RDIP	XL2/ XDON
D	$\overline{\text{CS}}$	XDI	$\overline{\text{WR/}}/\overline{\text{RW}}$	RPA	RPD	XL1/ XDOP	VDDR	VDDX	VSSX
E	ALE	A6	$\overline{\text{RD/}}/\overline{\text{DS}}$	A7	NC	VSS	DBW	VDD	IM
F	A5	A3	A1	A4	D8	D11	$\overline{\text{RES}}$	TMS	$\overline{\text{TRS}}$
G	A2	A0	D3	D5	D6	VDD	TCK	TDO	TDI
H	VSS	D0	D2	D4	D9	D12	D13	NC	NC
J	VDD	D1	VSS	VDD	D7	D10	VSS	D14	D15

F0119_2

Figure 5 Pin Configuration P-LBGA-81-1 (bottom view)

	1	2	3	4	5	6	7	8	9
A	VSSR	SYNC	RCLK	NC	VDD	RPB	SCLKR	XPC	XPB
B	RL2/ RDIN	NC	SEC/ FSC	CLK1	RPC	RDO	XPD	XPA	VSS
C	XL2/ XDON	RL1/ RDIP	CLK2	MCLK	VSS	SCLKX	INT	VDD	$\overline{\text{BHE/}}$ $\overline{\text{BLE}}$
D	VSSX	VDDX	VDDR	XL1/ XDOP	RPD	RPA	$\overline{\text{WR/}}$ $\overline{\text{RW}}$	XDI	$\overline{\text{CS}}$
E	IM	VDD	DBW	VSS	NC	A7	$\overline{\text{RD/DS}}$	A6	ALE
F	$\overline{\text{TRS}}$	TMS	$\overline{\text{RES}}$	D11	D8	A4	A1	A3	A5
G	TDI	TDO	TCK	VDD	D6	D5	D3	A0	A2
H	NC	NC	D13	D12	D9	D4	D2	D0	VSS
J	D15	D14	VSS	D10	D7	VDD	VSS	D1	VDD

F0119_3

Figure 6 Pin Configuration P-LBGA-81-1 (top view)

2.3 Pin Definitions and Functions

Table 1 Pin Definitions - Microprocessor Interface

Pin No.	Ball No.	Symbol	Input (I) Output (O) Supply (S)	Function
50 49 48 47 46 45 44 43	E6 E8 F9 F6 F8 G9 F7 G8	A7 A6 A5 A4 A3 A2 A1 A0	I + PU	Address Bus These inputs interface with eight bits of the system's address bus to select one of the internal registers for read or write.
21 22 23 26 27 28 29 30 31 32 33 36 37 38 39 40	J1 J2 H3 H4 F4 J4 H5 F5 J5 G5 G6 H6 G7 H7 J8 H8	D15 D14 D13 D12 D11 D10 D9 D8 D7 D6 D5 D4 D3 D2 D1 D0	I/O + PU	Data Bus Bidirectional tristate data lines which interface with the system's data bus. Their configuration is controlled by the level of pin DBW: 8-bit mode (DBW = 0): D(7:0) are active. D(15:8) are internally pulled high. 16-bit mode (DBW = 1): D(15:0) are active. In case of byte transfers, the active half of the bus is determined by A0 and BHE/BL \bar{E} and the selected bus interface mode (via pin IM). The unused half is internally pulled high.

Pin Descriptions

Table 1 Pin Definitions - Microprocessor Interface (cont'd)

Pin No.	Ball No.	Symbol	Input (I) Output (O) Supply (S)	Function
51	E9	ALE	I + PU	<p>Address Latch Enable A high on this line indicates an address on an external multiplexed address/data bus. The address information provided on lines A(7:0) is internally latched with the falling edge of ALE. This function allows the FALC[®]56 to be connected to a multiplexed address/data bus without the need for external latches. In this case, pins A(7:0) must be connected to the data bus pins externally. In case of demultiplexed mode this pin can be connected directly to V_{DD} or can be left open.</p>
52	E7	$\overline{RD/DS}$	I + PU	<p>Read Enable (Intel bus mode) This signal indicates a read operation. When the FALC[®]56 is selected via \overline{CS}, the \overline{RD} signal enables the bus drivers to output data from an internal register addressed by A(7:0) to the Data Bus. Data Strobe (Motorola bus mode) This pin serves as input to control read/write operations.</p>
53	D7	$\overline{WR/RW}$	I + PU	<p>Write Enable (Intel bus mode) This signal indicates a write operation. When \overline{CS} is active the FALC[®]56 loads an internal register with data provided on the data bus. Read/Write Enable (Motorola bus mode) This signal distinguishes between read and write operation.</p>
12	E3	DBW	I + PU	<p>Data Bus Width (Bus interface mode) A low signal on this input selects the 8-bit bus interface mode. A high signal on this input selects the 16-bit bus interface mode. In this case word transfer to/from the internal registers is enabled. Byte transfers are implemented by using $A0$ and $\overline{BHE/BLE}$.</p>

Table 1 Pin Definitions - Microprocessor Interface (cont'd)

Pin No.	Ball No.	Symbol	Input (I) Output (O) Supply (S)	Function
11	E1	IM	I + PU	<p>Interface Mode The level at this pin defines the bus interface mode: A low signal on this input selects the Intel interface mode. A high signal on this input selects the Motorola interface mode.</p>
54	D9	$\overline{\text{CS}}$	I + PU	<p>Chip Select A low signal selects the FALC[®]56 for read and write operations. This allows to connect multiple devices to a single data/address bus.</p>
55	C9	$\overline{\text{BHE}}$ / BLE	I + PU	<p>Bus High Enable (Intel bus mode) If 16-bit bus interface mode is enabled, this signal indicates a data transfer on the upper byte of the data bus D(15:8). In 8-bit bus interface mode this signal has no function and should be tied to V_{DD} or left open.</p> <p>Bus Low Enable (Motorola bus mode) If 16-bit bus interface mode is enabled, this signal indicates a data transfer on the lower byte of the data bus D(7:0). In 8-bit bus interface mode this signal has no function and should be tied to V_{DD} or left open.</p>
57	C7	INT	O/oD	<p>INTerrupt Request INT serves as general interrupt request for all interrupt sources. These interrupt sources can be masked via registers IMR(5:0). Interrupt status is reported via registers GIS (Global Interrupt Status) and ISR(5:0). Output characteristics (push-pull active low/high, open drain) are determined by programming register IPC. (oD = open drain output)</p>

Table 2 Pin Definitions - Line Interface

Pin No.	Ball No.	Symbol	Input (I) Output (O) Supply (S)	Function
Line Interface Receive				
3	C2	RL1	I (analog)	Line Receiver 1 Analog input from the external transformer. Selected if LIM1.DRS is cleared.
		RDIP	I	Receive Data Input Positive Digital input for received dual-rail PCM(+) route signal which is latched with the internally recovered receive route clock. An internal DPLL extracts the receive route clock from the incoming data pulses. The duty cycle of the received signal has to be close to 50%. The dual-rail mode is selected if LIM1.DRS and FMR0.RC1 are set. Input polarity is selected by bit RC0.RDIS (after reset: active low), line coding is selected by FMR0.RC(1:0).
		ROID	I	Receive Optical Interface Data Unipolar data received from a fiber-optical interface with 2048 kbit/s (E1) or 1544 kbit/s (T1/J1). Latching of data is done with the falling edge of RCLKI. Input polarity is selected by bit RC0.RDIS. The single-rail mode is selected if LIM1.DRS is set and FMR0.RC1 is cleared. If CMI coding is selected (FMR0.RC(1:0) = 01), an internal DPLL recovers clock and data; no clock signal on RCLKI is required.

Table 2 Pin Definitions - Line Interface (cont'd)

Pin No.	Ball No.	Symbol	Input (I) Output (O) Supply (S)	Function
2	B1	RL2	I (analog)	Line Receiver 2 Analog input from the external transformer. Selected if LIM1.DRS is cleared.
		RDIN	I	Receive Data Input Negative Input for received dual-rail PCM(-) route signal which is latched with the internally recovered receive route clock. An internal DPLL extracts the receive route clock from the incoming data pulses. The duty cycle of the received signal has to be close to 50%. The dual-rail mode is selected if LIM1.DRS and FMR0.RC1 are set. Input polarity is selected by bit RC0.RDIS (after reset: active low), line coding is selected by FMR0.RC(1:0).
		RCLKI	I	Receive Clock Input Receive clock input for the optical interface if LIM1.DRS is set and FMR0.RC(1:0) = 00. Clock frequency: 2.048 MHz (E1) or 1.544 MHz (T1/J1). RCLKI is ignored if CMI coding is selected.

Table 2 Pin Definitions - Line Interface (cont'd)

Pin No.	Ball No.	Symbol	Input (I) Output (O) Supply (S)	Function
Line Interface Transmit				
7	D4	XL1	O (analog)	Transmit Line 1 Analog output to the external transformer. Selected if LIM1.DRS is cleared. After reset this pin is in high-impedance state until bit FMR0.XC1 is set and XPM2.XLT is cleared.
		XDOP	O	Transmit Data Output Positive This digital output for transmitted dual-rail PCM(+) route signals can provide - half banded signals with 50% duty cycle (LIM0.XFB = 0) or - full banded signals with 100% duty cycle (LIM0.XFB = 1) The data is clocked with positive transitions of XCLK in both cases. Output polarity is selected by bit LIM0.XDOS (after reset: active low). The dual-rail mode is selected if LIM1.DRS and FMR0.XC1 are set. After reset this pin is in high-impedance state until register LIM1.DRS is set and XPM2.XLT is cleared.
		XOID	O	Transmit Optical Interface Data Unipolar data sent to a fiber-optical interface with 2048 kbit/s (E1) or 1544 kbit/s (T1/J1) which is clocked on the positive transitions of XCLK. Clocking of data in NRZ code is done with 100% duty cycle. Data in CMI code is shifted out with 50% or 100% duty cycle on both transitions of XCLK according to the CMI coding. Output polarity is selected by bit LIM0.XDOS (after reset: data is sent active high). The single-rail mode is selected if LIM1.DRS is set and FMR0.XC1 is cleared. After reset this pin is in high-impedance state until register LIM1.DRS is set and XPM2.XLT is cleared.

Pin Descriptions

Table 2 Pin Definitions - Line Interface (cont'd)

Pin No.	Ball No.	Symbol	Input (I) Output (O) Supply (S)	Function
5	C1	XL2	O (analog)	<p>Transmit Line 2 Analog output for the external transformer. Selected if LIM1.DRS is cleared. After reset this pin is in high-impedance state until bit FMR0.XC1 is set and XPM2.XLT is cleared.</p>
		XDON	O	<p>Transmit Data Output Negative This digital output for transmitted dual-rail PCM(-) route signals can provide - half banded signals with 50% duty cycle (LIM0.XFB = 0) or - full banded signals with 100% duty cycle (LIM0.XFB = 1) The data is clocked on positive transitions of XCLK in both cases. Output polarity is selected by bit LIM0.XDOS (after reset: active low). The dual-rail mode is selected if LIM1.DRS and FMR0.XC1 are set. After reset this pin is in high-impedance state until register LIM1.DRS is set and XPM2.XLT cleared.</p>
		XFM	O	<p>Transmit Frame Marker This digital output marks the first bit of every frame transmitted on port XDOP. This function is only available in the optical interface mode (LIM1.DRS = 1 and FMR0.XC1 = 0). Data is clocked on positive transitions of XCLK. After reset this pin is in high-impedance state until register LIM1.DRS is set and XPM2.XLT cleared. In remote loop configuration the XFM marker is not valid.</p>

Table 3 Pin Definitions - Clock Generation

Pin No.	Pin No.	Symbol	Input (I) Output (O) Supply (S)	Function
73	C4	MCLK	I	<p>Master Clock</p> <p>A reference clock of better than ± 32 ppm accuracy in the range of 1.02 to 20 MHz must be provided on this pin. The FALC[®]56 internally derives all necessary clocks from this master (see registers GCM(6:1)).</p>
79	A2	SYNC	I + PU	<p>Clock Synchronization of DCO-R</p> <p>If a clock is detected on pin SYNC the DCO-R circuitry of the FALC[®]56 synchronizes to this 1.544/2.048 MHz clock (see LIM0.MAS, CMR1.DCS and CMR2.DCF). Additionally, in master mode the FALC[®]56 is able to synchronize to an 8-kHz reference clock (IPC.SSYF = 1). If not connected, an internal pullup transistor ensures high input level.</p>
76	B4	CLK1	O + PU	<p>System Clock of DCO-R</p> <p>Output of the de-jittered system clock generated by the DCO-R circuit. Frequency selection is done by setting control bits in PC5/6.</p> <p>E1: 16.384 MHz, 8.192 MHz, 4.096 MHz, 2.048 MHz or 8 kHz T1/J1: 16.384 MHz, 12.352 MHz, 8.192 MHz, 6.176 MHz, 4.096 MHz, 3.088 MHz, 2.048 MHz, 1.544 MHz or 8 kHz</p> <p>After reset this output is inactive and internally pulled high.</p> <p>Note: If DCO-R is not active, no clock is output on pin CLK1 (SIC1.RBS(1:0) = 11 and CMR1.RS1 = 0).</p>

Table 3 Pin Definitions - Clock Generation (cont'd)

Pin No.	Pin No.	Symbol	Input (I) Output (O) Supply (S)	Function
77	C3	CLK2	O + PU	<p>System Clock of DCO-X Output of the de-jittered system clock generated by the DCO-X circuit. Frequency selection is done by setting control bits in PC5/6. E1: 16.384 MHz, 8.192 MHz, 4.096 MHz or 2.048 MHz T1/J1: 12.352 MHz, 6.176 MHz, 3.088 MHz or 1.544 MHz After reset this output is inactive and internally pulled high. Note: If DCO-X is not used, no clock is output on pin CLK2 (SIC1.XBS(1:0) = 00 and CMR1.DXJA = 1; buffer bypass and no jitter attenuation)</p>
78	B3	SEC	I + PU	<p>One-Second Timer Input A pulse with logical high level for at least two 2.048-MHz cycles triggers the internal one-second timer. After reset this pin is configured to be an input. If not connected, an internal pullup transistor ensures high input level (see register GPC1).</p>
			O	<p>One-Second Timer Output Activated high every second for two 2.048-MHz clock cycles.</p>
		FSC	O	<p>Optionally an 8-kHz frame synchronization pulse is output via this pin. The synchronization pulse is active high or low for one 2.048/1.544-MHz cycle (pulse width = 488 ns for E1 and 648 ns or T1/J1).</p>

Table 3 Pin Definitions - Clock Generation (cont'd)

Pin No.	Pin No.	Symbol	Input (I) Output (O) Supply (S)	Function
75	A3	RCLK	O + PU	<p>Receive Clock</p> <p>After reset this port is configured to be internally pulled up weakly. Setting of bit PC5.CRP switches this port to be an active output.</p> <p>CMR1.RS(1:0) = 00: Receive clock extracted from the incoming data pulses. The clock frequency is 2.048 MHz (E1) or 1.544 MHz (T1/J1). In case of Loss-Of-Signal (LOS) the RCLK is derived from the clock that is provided on MCLK.</p> <p>CMR1.RS(1:0) = 01: Receive clock extracted from the incoming data pulses. The clock frequency is 2.048 MHz (E1) or 1.544 MHz (T1/J1). RCLK remains high in case of LOS (indicated by FRS0.LOS = 1).</p> <p>CMR1.RS(1:0) = 10: Dejittered clock generated by the internal DCO-R circuit. The clock frequency is 2.048 MHz (E1 or T1/J1 and SIC2.SSC2 = 0) or 1.544 MHz (T1/J1 and SIC2.SSC2 = 1).</p> <p>CMR1.RS(1:0) = 11: Dejittered clock generated by the internal DCO-R circuit. The clock frequency is 8.192 MHz (E1 or T1/J1 and SIC2.SSC2 = 0) or 6.176 MHz (T1/J1 and SIC2.SSC2 = 1).</p>

Table 4 Pin Definitions - System Interface

Pin No.	Ball No.	Symbol	Input (I) Output (O) Supply (S)	Function
System Interface Receive				
66	B6	RDO	O	<p>Receive Data Out</p> <p>Received data that is sent to the system highway. Clocking of data is done with the rising or falling edge (SIC3.RESR) of SCLKR or RCLK, if the receive elastic store is bypassed. The delay between the beginning of time slot 0 and the initial edge of SCLKR (after $\overline{\text{SYPR}}$ goes active) is determined by the values of registers RC1 and RC0.</p> <p>If received data is shifted out with higher (more than 2.048/1.544 Mbit/s) data rates, the active channel phase is defined by bits SIC2.SICS(2:0). During inactive channel phases RDO is cleared (driven to low level, not tristate).</p>
65	A7	SCLKR	I/O + PU	<p>System Clock Receive</p> <p>Working clock for the receive system interface with a frequency of 16.384/8.192/4.096/2.048 MHz in E1 mode and 16.384/8.192/4.096/2.048 MHz (SIC2.SSC2 = 0) or 12.352/6.176/3.088/1.544 MHz (SIC2.SSC2 = 1) in T1/J1 mode. If the receive elastic store is bypassed, the clock supplied on this pin is ignored, because RCLK is used to clock the receive system interface.</p> <p>If SCLKR is configured to be an output, the internal working clock of the receive system interface sourced by DCO-R or RCLK is output.</p>

Table 4 Pin Definitions - System Interface (cont'd)

Pin No.	Ball No.	Symbol	Input (I) Output (O) Supply (S)	Function
67	D6	RPA	I/O + PU	<p>Receive Multifunction Port A to D Depending on programming of bits PC(1:4).RPC(2:0) these multifunction ports carry information to the system interface or from the system to the FALC[®]56. After reset these ports are configured to be inputs. With the selection of the appropriate pin function, the corresponding input/output configuration is achieved automatically. Depending on bit SIC3.RESR latching/transmission of data is done with the rising or falling edge of SCLKR. If not connected, an internal pullup transistor ensures a high input level. The input function must not be selected twice or more.</p> <p>Selectable pin functions are described below.</p>
68	A6	RPB		
69	B5	RPC		
70	D5	RPD		
			I + PU	<p>Synchronous Pulse Receive (SYPR) PC(4:1).RPC(2:0) = 000</p> <p>Together with the values of registers RC(1:0) this signal defines the beginning of time slot 0 on system highway port RDO .</p> <p>Only one multifunction port may be selected as $\overline{\text{SYPR}}$ input. After reset, $\overline{\text{SYPR}}$ of port A is used, the other lines are ignored.</p> <p>$\overline{\text{SYPR}}$ cannot be used in combination with RFM.</p> <p>The pulse cycle is an integer multiple of 125 μs.</p>

Table 4 Pin Definitions - System Interface (cont'd)

Pin No.	Ball No.	Symbol	Input (I) Output (O) Supply (S)	Function
67	D6	RPA	O	<p>Receive Frame Marker (RFM) PC(4:1).RPC(2:0) = 001</p> <p>CMR2.IRSP = 0: The receive frame marker can be active high for a 2.048-MHz (E1) or 1.544-MHz (T1/J1) period during any bit position of the current frame. It is clocked off with the rising or falling edge of SCLKR or RCLK, depending on SIC3.RESR. Offset programming is done by using registers RC(1:0).</p> <p>CMR2.IRSP = 1: Frame synchronization pulse generated by the DCO-R circuitry internally. Together with registers RC(1:0) the frame begin on the receive system interface is defined. This frame synchronization pulse is active low for a 2.048-MHz (E1) or 1.544-MHz (T1/J1) period.</p>
68	A6	RPB		
69	B5	RPC		
70	D5	RPD		
			O	<p>Receive Multiframe Begin (RMFB) PC(1:4).RPC(2:0) = 010</p> <p>In E1 mode RMFB marks the beginning of every received multiframe (RDO). Optionally the time slot 16 CAS multiframe begin can be marked (SIC3.CASMF). Active high for one 2.048-MHz period.</p> <p>In T1/J1 mode the function depends on bit XC0.MFBS: MFBS = 1: RMFB marks the beginning of every received multiframe (RDO). MFBS = 0: RMFB marks the beginning of every received superframe. Additional pulses are provided every 12 frames when using ESF/F24 or F72 format.</p>

Table 4 Pin Definitions - System Interface (cont'd)

Pin No.	Ball No.	Symbol	Input (I) Output (O) Supply (S)	Function
67	D6	RPA	O	Receive Signaling Marker (RSIGM) PC(1:4).RPC(2:0) = 011
68	A6	RPB		E1: Marks the time slots which are defined by register RTR(4:1) of every received frame on port RDO. T1/J1: Marks the time slots which are defined by register RTR(4:1) of every received frame on port RDO, if CAS-BR is not used. When using the CAS-BR signaling scheme, the robbed bit of each channel every sixth frames is marked, if CAS-BR is enabled by XC0.BRM = 1.
69	B5	RPC		
70	D5	RPD		
			O	
			O	The received CAS signaling data is sourced by this pin. Time slots on RSIG correlate directly to the time slot assignment on RDO.
			O	Data Link Bit Receive (DLR) PC(1:4).RPC(2:0) = 101
				E1: Marks the S _a (8:4)-bits within the data stream on RDO. The S _a (8:4)-bit positions in time slot 0 of every frame not containing the frame alignment signal are selected by register XC0. T1/J1: Marks the DL-bit position within the data stream on RDO.

Table 4 Pin Definitions - System Interface (cont'd)

Pin No.	Ball No.	Symbol	Input (I) Output (O) Supply (S)	Function
67 68 69 70	D6 A6 B5 D5	RPA RPB RPC RPD	O	<p>Frame Synchronous Pulse ($\overline{\text{RFSP}}$) PC(1:4).RPC(2:0) = 111</p> <p>Active low framing pulse derived from the received PCM route signal (line side, RCLK). During loss of synchronization (bit FRS0.LFA = 1), this pulse is suppressed (not influenced during alarm simulation). Pulse frequency: 8 kHz Pulse width: 488 ns (E1) or 648 ns (T1/J1).</p>
System Interface Transmit				
56	D8	XDI	I	<p>Transmit Data In</p> <p>Transmit data received from the system highway. Latching of data is done with rising or falling transitions of SCLKX according to bit SIC3.RESX. The delay between the beginning of time slot 0 and the initial edge of SCLKX (after $\overline{\text{SYPX}}$ goes active) is determined by the registers XC(1:0). In higher (more than 1.544/2.048 Mbit/s) data rates sampling of data is defined by bits SIC2.SICS(2:0).</p>
64	C6	SCLKX	I + PU	<p>System Clock Transmit</p> <p>Working clock for the transmit system interface with a frequency of 16.384/8.192/4.096/2.048 MHz (SIC2.SSC2 = 0) or 12.352/6.176/3.088/1.544 MHz (SIC2.SSC2 = 1) in T1/J1 mode.</p>

Table 4 Pin Definitions - System Interface (cont'd)

Pin No.	Ball No.	Symbol	Input (I) Output (O) Supply (S)	Function
60	B8	XPA	I/O + PU	<p>Transmit Multifunction Port A to D</p> <p>Depending on programming of bits PC(1:4).XPC(3:0) these multifunction ports carry information to the system interface or from the system to the FALC[®]56. After reset the ports are configured to be inputs. With the selection of the appropriate pin function, the corresponding input/output configuration is achieved automatically. Depending on bit SIC3.RESX latching/transmission of data is done with the rising or falling edge of SCLKX. If not connected, an internal pullup transistor ensures a high input level.</p> <p>Each input function ($\overline{\text{SYPX}}$, XMFS, XSIG or TCLK) may only be selected once. SYPX and XMFS must not be used in parallel.</p> <p>Selectable pin functions are described below.</p>
61	A9	XPB		
62	A8	XPC		
63	B7	XPD		

Table 4 Pin Definitions - System Interface (cont'd)

Pin No.	Ball No.	Symbol	Input (I) Output (O) Supply (S)	Function
60	B8	XPA	I + PU	<p>Synchronous Pulse Transmit (SYPX) PC(1:4).XPC(3:0) = 0000</p> <p>Together with the values of registers XC(0:1) this signal defines the beginning of time slot 0 at system highway port XDI .</p> <p>The pulse cycle is an integer multiple of 125 μs.</p> <p>$\overline{\text{SYPX}}$ must not be used in parallel with XMFS.</p>
61	A9	XPB		
62	A8	XPC		
63	B7	XPD		
			I + PU	<p>Transmit Multiframe Synchronization (XMFS) PC(1:4).XPC(3:0) = 0001</p> <p>This port defines the frame and multiframe begin on the transmit system interface ports XDI and XSIG. Depending on PC5.CXMFS the signal on XMFS is active high or low. XMFS must not be used in parallel with $\overline{\text{SYPX}}$.</p> <p>Note: A new multiframe position has settled at least one multiframe after pulse XMFS has been supplied.</p>
			I + PU	<p>Transmit Signaling Data (XSIG) PC(1:4).XPC(3:0) = 0010</p> <p>Input for transmit signaling data received from the signaling highway. Optionally, (SIC3.TTRF = 1), sampling of XSIG data is controlled by the active high XSIGM marker. At higher data rates sampling of data is defined by bits SIC2.SICS(2:0).</p>

Table 4 Pin Definitions - System Interface (cont'd)

Pin No.	Ball No.	Symbol	Input (I) Output (O) Supply (S)	Function
60	B8	XPA	I + PU	Transmit Clock (TCLK) PC(1:4).XPC(3:0) = 0011
61	A9	XPB		A 2.048/8.192-MHz (E1) or 1.544/6.176-MHz (T1/J1) clock has to be sourced by the system if the internally generated transmit clock (generated by DCO-X) shall not be used. Optionally this input is used as a synchronization clock for the DCO-X circuitry with a frequency of 2.048 (E1) or 1.544 MHz (T1/J1).
62	A8	XPC		
63	B7	XPD		
			O	Transmit Multiframe Begin (XMFB) PC(1:4).XPC(3:0) = 0100 XMFB marks the beginning of every transmitted multiframe on XDI. The signal is active high for one 2.048 (E1) or 1.544 MHz (T1/J1) period.
			O	Transmit Signaling Marker (XSIGM) PC(1:4).XPC(3:0) = 0101 E1: Marks the transmit time slots on XDI of every frame which are defined by register TTR(1:4). T1/J1: Marks the transmit time slots on XDI of every frame which are defined by register TTR(1:4) (if not CAS-BR is used). When using the CAS-BR signaling scheme the robbed bit of each channel in every sixth frame is marked.

Table 4 Pin Definitions - System Interface (cont'd)

Pin No.	Ball No.	Symbol	Input (I) Output (O) Supply (S)	Function
60	B8	XPA	O	Data Link Bit Transmit (DLX) PC(1:4).XPC(3:0) = 0110
61	A9	XPB		E1: Marks the S _a (8:4)-bits within the data stream on XDI. The S _a (8:4)-bit positions in time slot 0 of every frame not containing the frame alignment signal are selected by register XC0.SA8E to XC0.SA4E.
62	A8	XPC		
63	B7	XPD		T1/J1: This output provides a 4-kHz signal which marks the DL-bit position within the data stream on XDI (in ESF mode only).
			O	Transmit Clock (XCLK) PC(1:4).XPC(3:0) = 0111
				Transmit line clock of 2.048 MHz (E1) or 1.544 MHz (T1/J1) derived from SCLKX/R, RCLK or generated internally by DCO circuitries.
			I + PU	Transmit Line Tristate (XLT) PC(1:4).XPC(3:0) = 1000
				A high level on this port sets the transmit lines XL1/2 or XDOP/N into tristate mode. This pin function is logically ored with register bit XPM2.XLT.

Table 5 Pin Definitions - Miscellaneous

Pin No.	Ball No.	Symbol	Input (I) Output (O) Supply (S)	Function
Power Supply				
4	D3	V_{DDR}	S	Positive Power Supply for the analog receiver
1	A1	V_{SSR}	S	Power Ground for the analog receiver
6	D2	V_{DDX}	S	Positive Power Supply for the analog transmitter
8	D1	V_{SSX}	S	Power Ground for the analog transmitter
9 24 34 41 58 71	A5 C8 E2 G4 J6 J9	V_{DD}	S	Positive Power Supply for the digital subcircuits (3.3 V) For correct operation, all six pins have to be connected to positive power supply.
10 25 35 42 59 72	B9 C5 E4 H9 J3 J7	V_{SS}	S	Power Ground for digital subcircuits (0 V) For correct operation, all six pins have to be connected to ground.
Device Reset				
13	F3	\overline{RES}	I	Reset A low signal on this pin forces the FALC [®] 56 into reset state. During reset the FALC [®] 56 needs an active clock on pin MCLK. During reset all bidirectional output stages are in input mode, if signal \overline{RD} is "high" (to disable the data bus output drivers).

Table 5 Pin Definitions - Miscellaneous (cont'd)

Pin No.	Ball No.	Symbol	Input (I) Output (O) Supply (S)	Function
Unused Pins				
19	A4	N.C.		not connected, to be left open for compatibility with future products.
20	B2			
74	E5			
80	H1 H2			
Boundary Scan/Joint Test Access Group (JTAG)				
14	F1	$\overline{\text{TR}}\text{S}$	I + PU	Test Reset for Boundary Scan (active low). If not connected, an internal pullup transistor ensures high input level. If the JTAG boundary scan is not used, this pin must be connected to $\overline{\text{RES}}$ or V_{SS} .
15	G1	TDI	I + PU	Test Data Input for Boundary Scan If not connected an internal pullup transistor ensures high input level.
16	F2	TMS	I + PU	Test Mode Select for Boundary Scan If not connected an internal pullup transistor ensures high input level.
17	G3	TCK	I + PU	Test Clock for Boundary Scan If not connected an internal pullup transistor ensures high input level.
18	G2	TDO	O	Test Data Output for Boundary Scan

Note: oD = open drain output

PU = input or input/output comprising an internal pullup device

To override the internal pullup by an external pulldown, a resistor value of 22 k Ω is recommended.

The pullup devices are activated during reset, this means their state is undefined until the reset signal has been applied.

Unused pins containing pullups can be left open.

3 Functional Description E1/T1/J1

3.1 Functional Overview

The FALC[®] device contains analog and digital function blocks that are configured and controlled by an external microprocessor or microcontroller.

The main interfaces are

- Receive and transmit line interface
- PCM system highway interface/H.100 bus
- Microprocessor interface
- Boundary scan interface

as well as several control lines for reset and clocking purpose.

The main internal functional blocks are

- Analog line receiver with equalizer network and clock/data recovery
- Analog line driver with programmable pulse shaper and line build out
- Central clock generation module
- Elastic buffers for receive and transmit direction
- Receive Framer, receive line decoding, alarm detection, PRBS and performance monitoring
- Transmit framer, receive line encoding, alarm and PRBS generation
- Receive jitter attenuator
- Transmit jitter attenuator
- Three HDLC controllers (one of them including SS7 and BOM support) and CAS signaling controller
- Test functions (loop switching local - remote - payload - single channel)
- Register access interface
- Boundary scan control

3.2 Block Diagram

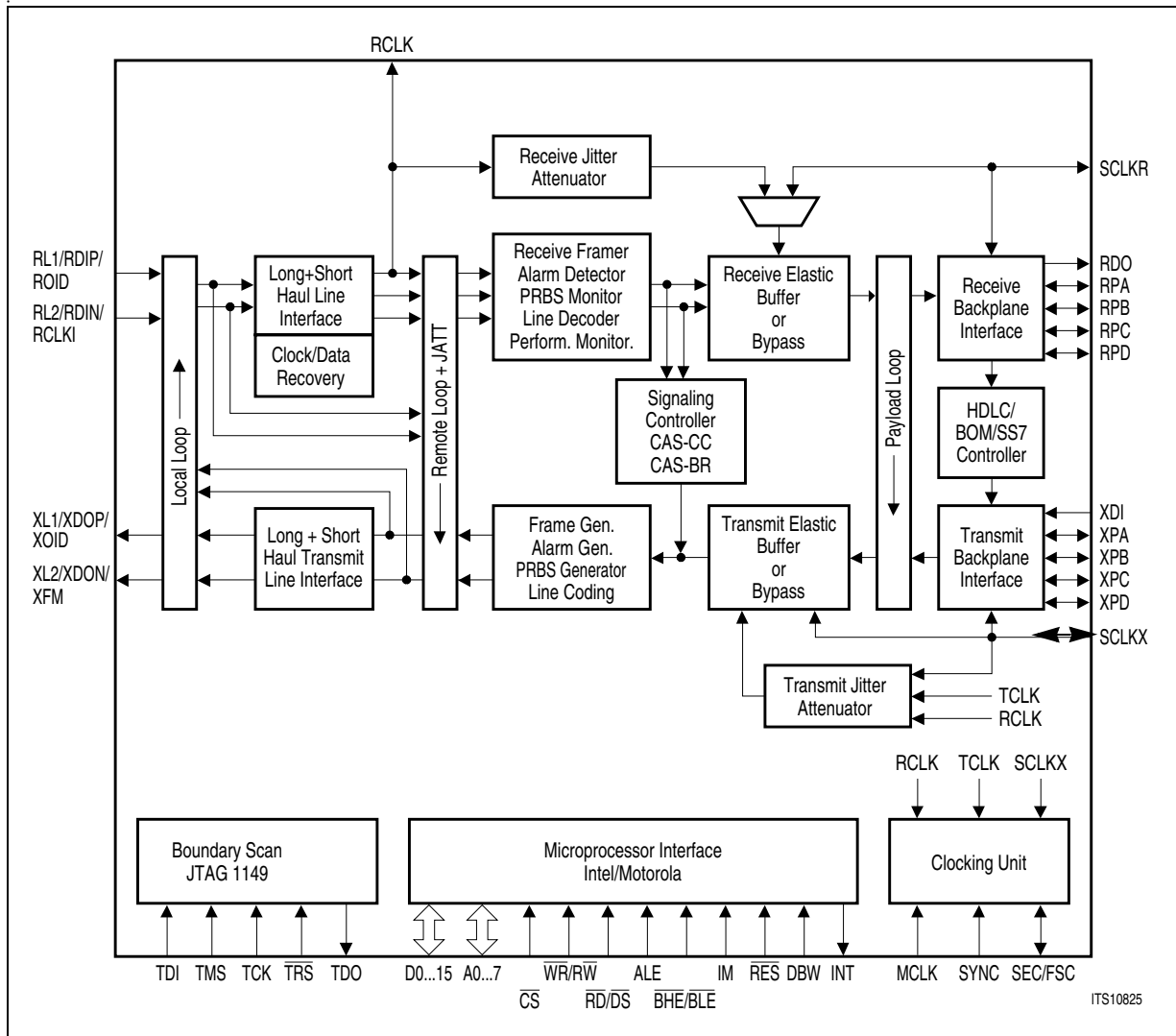

Figure 7 Block Diagram

3.3 Functional Blocks

3.3.1 Microprocessor Interface

The communication between the CPU and the FALC56 is done using a set of directly accessible registers. The interface can be configured as Intel or Motorola type with a selectable data bus width of 8 or 16 bits.

The CPU transfers data to and from the FALC56 (through 64-byte deep FIFOs per direction), sets the operating modes, controls function sequences, and gets status information by writing or reading control and status registers. All accesses can be done as byte or word accesses if enabled. If 16-bit bus width is selected, access to lower/upper part of the data bus is determined by address line A0 and signal BHE/BLE as shown in [Table 6](#) and [Table 7](#).

[Table 8](#) shows how the ALE (**A**ddress **L**atch **E**nable) line is used to control the bus structure and interface type. The switching of ALE allows the FALC56 to be directly connected to a multiplexed address/data bus.

3.3.1.1 Mixed Byte/Word Access to the FIFOs

Reading from or writing to the internal FIFOs (RFIFO and XFIFO) can be done using a 8-bit (byte) or 16-bit (word) access depending on the selected bus interface mode. Randomly mixed byte/word access to the FIFOs is allowed without any restrictions.

Table 6 Data Bus Access (16-Bit Intel Mode)

BHE	A0	Register Access	FALC56 Data Pins Used
0	0	FIFO word access Register word access (even addresses)	D(15:0)
0	1	Register byte access (odd addresses)	D(15:8)
1	0	Register byte access (even addresses)	D(7:0)
1	1	No transfer performed	None

Table 7 Data Bus Access (16-Bit Motorola Mode)

BLE	A0	Register Access	FALC56 Data Pins Used
0	0	FIFO word access Register word access (even addresses)	D(15:0)
0	1	Register byte access (odd addresses)	D(7:0)
1	0	Register byte access (even addresses)	D(15:8)
1	1	No transfer performed	None

Table 8 Selectable Bus and Microprocessor Interface Configuration

ALE	IM	Microprocessor interface	Bus Structure
V_{SS}/V_{DD}	1	Motorola	de-multiplexed
V_{SS}/V_{DD}	0	Intel	de-multiplexed
switching	0	Intel	multiplexed

The assignment of registers with even/odd addresses to the data lines in case of 16-bit register access depends on the selected microprocessor interface mode:

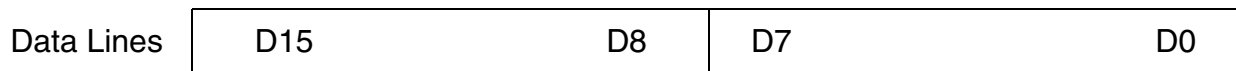
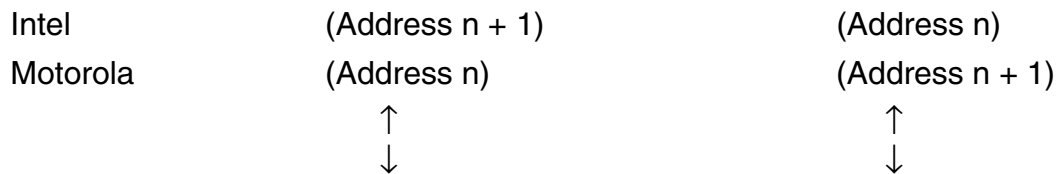

n: even address

3.3.1.2 FIFO Structure

In transmit and receive direction of the signaling controller 64-byte deep FIFOs are provided for the intermediate storage of data between the system internal highway and the CPU interface. The FIFOs are divided into two halves of 32 bytes. Only one half is accessible to the CPU at any time.

In case 16-bit data bus width is selected by fixing pin DBW to logical 1 word access to the FIFOs is enabled. Data output to bus lines D(15:0) as a function of the selected interface mode is shown in [Figure 8](#) and [Figure 9](#). Of course, byte access is also allowed. The effective length of the accessible part of RFIFO can be changed from 32 bytes (reset value) down to 2 bytes.

Functional Description E1/T1/J1

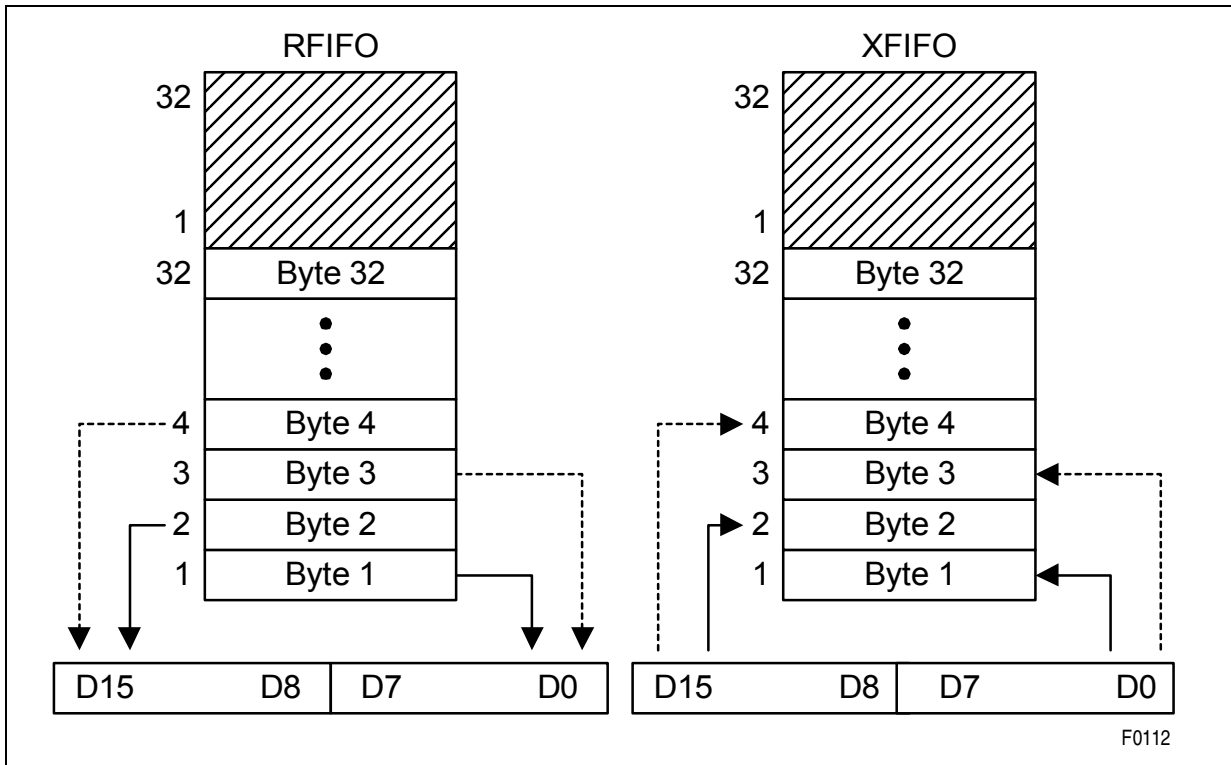

Figure 8 FIFO Word Access (Intel Mode)

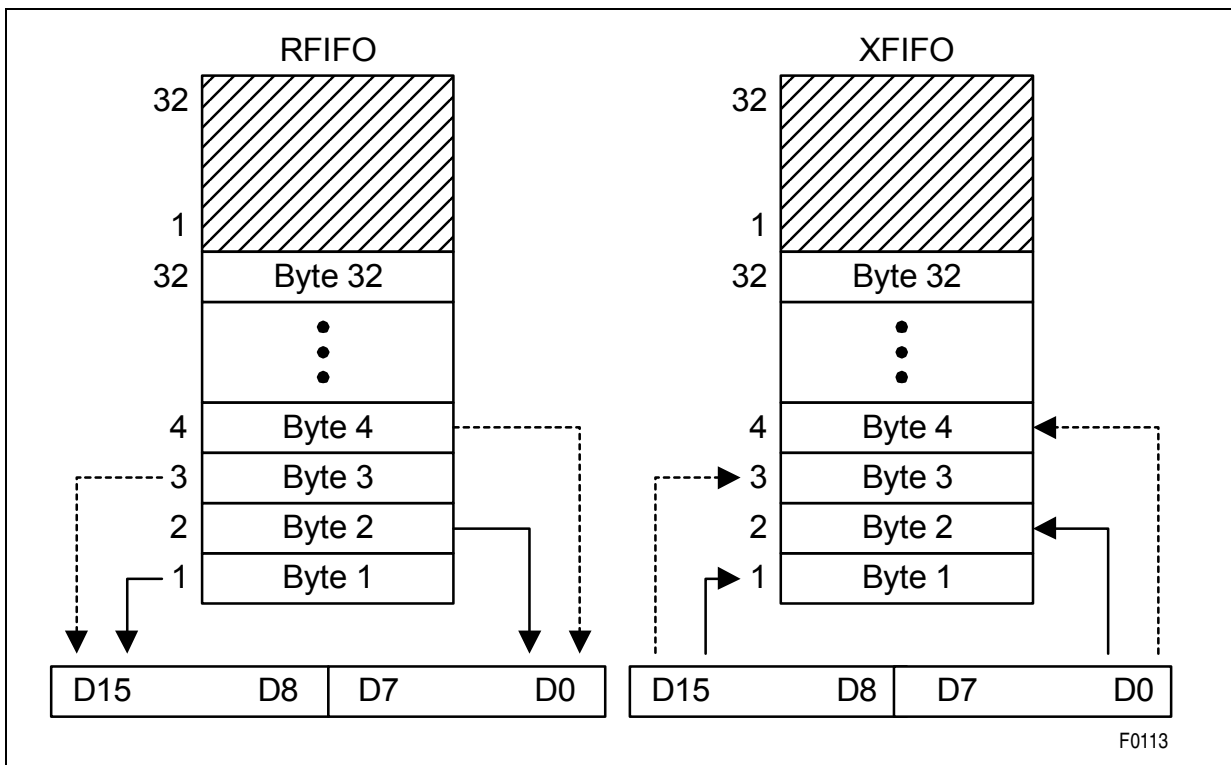

Figure 9 FIFO Word Access (Motorola Mode)

3.3.1.3 Interrupt Interface

Special events in the FALC[®] are indicated by means of a single interrupt output with programmable characteristics (open drain or push-pull, defined by register IPC), which requests the CPU to read status information from the FALC[®], or to transfer data from/to the FALC[®].

Since only one INT request output is provided, the cause of an interrupt must be determined by the CPU by reading the FALC[®]'s interrupt status registers (GIS, ISR(5:0)). The interrupt on pin INT and the interrupt status bits are reset by reading the interrupt status registers. Register ISR(5:0) are of type "clear on read".

The structure of the interrupt status registers is shown in **Figure 10**.

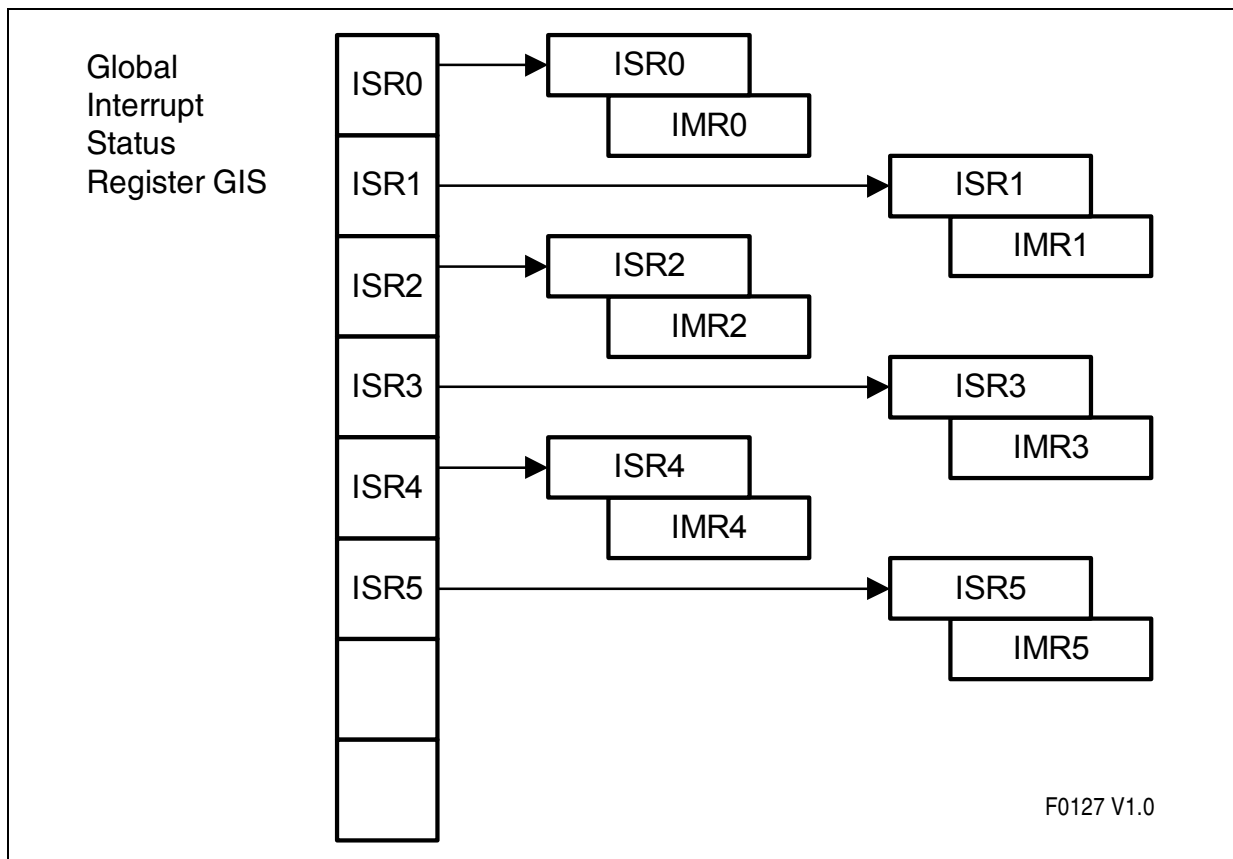

Figure 10 Interrupt Status Registers

Each interrupt indication of registers ISR(5:0) can be selectively masked by setting the corresponding bit in the corresponding mask registers IMR(5:0). If the interrupt status bits are masked they neither generate an interrupt at INT nor are they visible in ISR(5:0). GIS, the non-maskable Global Interrupt Status Register, serves as pointer to pending interrupts. After the FALC[®] has requested an interrupt by activating its INT pin, the CPU should first read the Global Interrupt Status register GIS to identify the requesting

Functional Description E1/T1/J1

interrupt source register. After reading the assigned interrupt status registers ISR(5:0), the pointer in register GIS is cleared or updated if another interrupt requires service.

If **all** pending interrupts are acknowledged by reading (GIS is reset), pin INT goes inactive.

Updating of interrupt status registers ISR(5:0) and GIS is only prohibited during read access.

Masked Interrupts Visible in Status Registers

- The Global Interrupt Status register (GIS) indicates those interrupt status registers with active interrupt indications (GIS.ISR(5:0)).
- An additional mode can be selected via bit GCR.VIS.
- In this mode, masked interrupt status bits neither generate an interrupt on pin INT nor are they visible in GIS, **but are displayed in the corresponding interrupt status register(s) ISR(5:0)**.

This mode is useful when some interrupt status bits are to be polled in the individual interrupt status registers.

Note: In the visible mode, all active interrupt status bits, whether the corresponding actual interrupt is masked or not, are reset when the interrupt status register is read. Thus, when polling of some interrupt status bits is desired, care must be taken that unmasked interrupts are not lost in the process.

Note: All unmasked interrupt statuses are treated as before.

Please note that whenever polling is used, all interrupt status registers concerned have to be polled individually (no "hierarchical" polling possible), since GIS only contains information on actually generated, i.e. unmasked interrupts.

3.3.2 Boundary Scan Interface

In the FALC56 a **Test Access Port (TAP)** controller is implemented. The essential part of the TAP is a finite state machine (16 states) controlling the different operational modes of the boundary scan. Both, TAP controller and boundary scan, meet the requirements given by the JTAG standard IEEE 1149.1. **Figure 11** gives an overview.

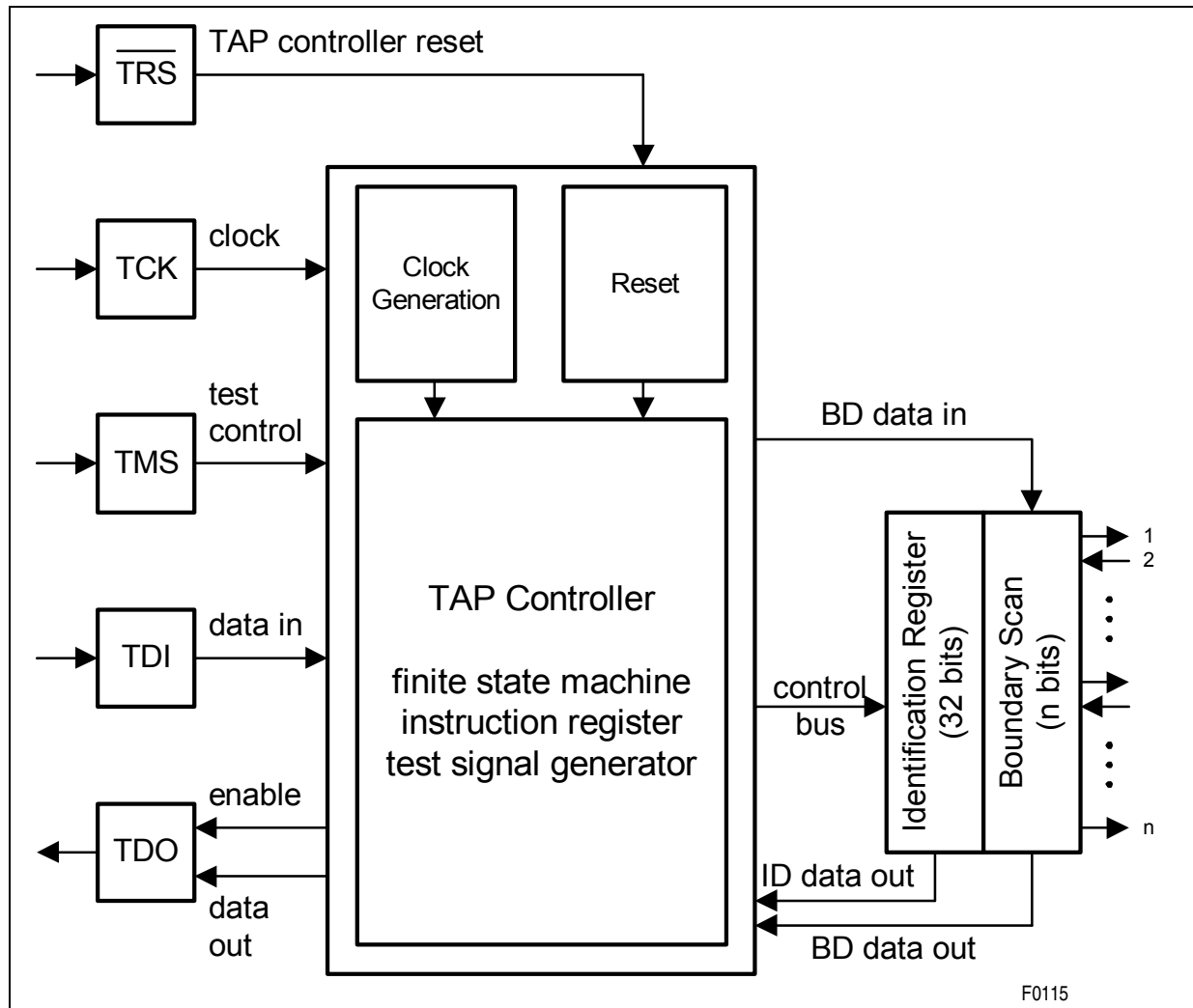

Figure 11 Block Diagram of Test Access Port and Boundary Scan

After switching on the device (power-on), a reset signal has to be applied to $\overline{\text{TRS}}$, which forces the TAP controller into test logic reset state.

For normal operation without boundary scan access, the boundary reset pin $\overline{\text{TRS}}$ can be tied to the device reset pin $\overline{\text{RES}}$.

The boundary length is 129.

Functional Description E1/T1/J1

If no boundary scan operation is used, $\overline{TR\overline{S}}$ has to be connected to $\overline{R\overline{ST}}$ or V_{SS} . TMS, TCK and TDI do not need to be connected since pullup transistors ensure high input levels in this case.

Test handling (boundary scan operation) is performed using the pins TCK (Test Clock), TMS (Test Mode Select), TDI (Test Data Input) and TDO (Test Data Output) when the TAP controller is not in its reset state, that means $\overline{TR\overline{S}}$ is connected to V_{DD} or it remains unconnected due to its internal pull up. Test data at TDI is loaded with a clock signal connected to TCK. "1" or "0" on TMS causes a transition from one controller state to another; constant "1" on TMS leads to normal operation of the chip.

An input pin (I) uses one boundary scan cell (data in), an output pin (O) uses two cells (data out and enable) and an I/O-pin (I/O) uses three cells (data in, data out and enable). Note that most functional output and input pins of the FALC56 are tested as I/O pins in boundary scan, hence using three cells. The desired test mode is selected by serially loading a 8-bit instruction code into the instruction register through TDI (LSB first).

EXTEST is used to examine the interconnection of the devices on the board. In this test mode at first all input pins capture the current level on the corresponding external interconnection line, whereas all output pins are held at constant values ("0" or "1"). Then the contents of the boundary scan is shifted to TDO. At the same time the next scan vector is loaded from TDI. Subsequently all output pins are updated according to the new boundary scan contents and all input pins again capture the current external level afterwards, and so on.

SAMPLE is a test mode which provides a snapshot of pin levels during normal operation.

IDCODE: A 32-bit identification register is serially read out on pin TDO. It contains the version number (4 bits), the device code (16 bits) and the manufacturer code (11 bits). The LSB is fixed to "1".

The ID code field is set to: 0001 0000 0000 0101 1001 0000 1000 0011

Version = 3_H, Part Number = 0059_H, Manufacturer = 083_H (including LSB, fixed to "1")

BYPASS: A bit entering TDI is shifted to TDO after one TCK clock cycle.

An alphabetical overview of all TAP controller operation codes is given in [Table 9](#).

Table 9 TAP Controller Instruction Codes

TAP Instruction	Instruction Code
BYPASS	11111111
EXTEST	00000000
IDCODE	00000100
SAMPLE	00000001
reserved for device test	01010011

3.3.3 Master Clocking Unit

The FALC56 provides a flexible clocking unit, which references to any clock in the range of 1.02 to 20 MHz supplied on pin MCLK.

The clocking unit has to be tuned to the selected reference frequency by setting the global clock mode registers GCM(6:1) accordingly.

The calculation formulas for the appropriate register settings can be found in [Chapter 9.2 on page 217](#) or [Chapter 10.2 on page 334](#). A calculation tool is available to evaluate the required register settings automatically (see [Chapter 13.3 on page 481](#)).

All required clocks for E1 or T1/J1 operation are generated by this circuit internally. The global setting depends only on the selected master clock frequency and is the same for E1 and T1/J1 because both clock rates are provided simultaneously.

To meet the E1 requirements the MCLK reference clock must have an accuracy of better than ± 32 ppm. The synthesized clock can be controlled on pins CLK1, CLK2, RCLK, SCLKR and XCLK.

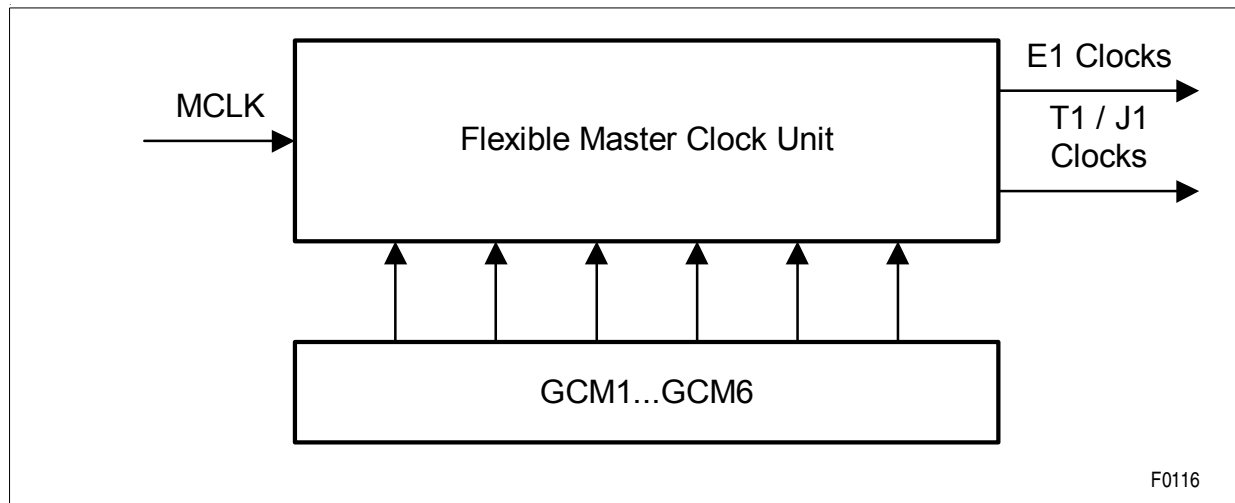

Figure 12 Flexible Master Clock Unit

4 Functional Description E1

4.1 Receive Path in E1 Mode

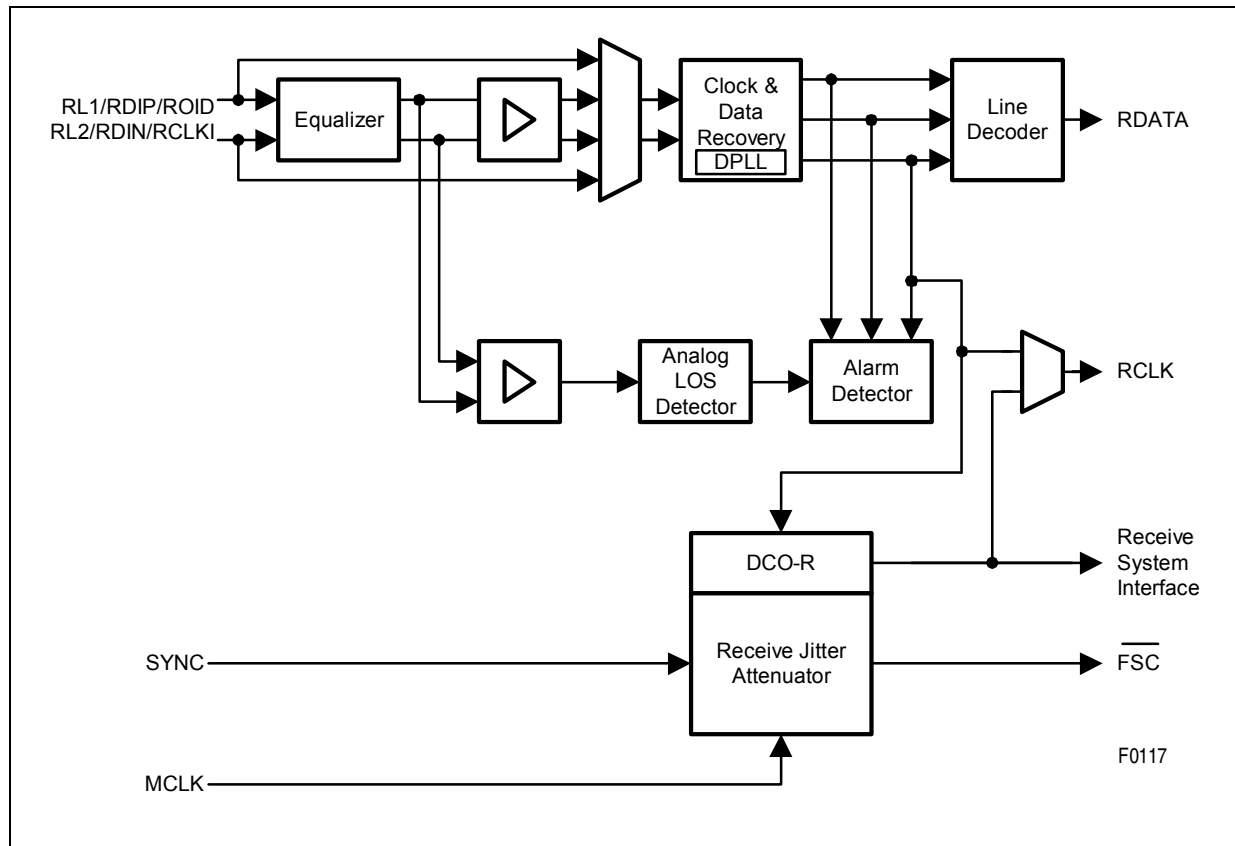

Figure 13 Receive Clock System (E1)

4.1.1 Receive Line Interface

For data input, three different data types are supported:

- Ternary coded signals received at multifunction ports RL1 and RL2 from a -10 dB (short-haul, LIM0.EQON = 0) or -43 dB (long-haul, LIM0.EQON = 1) ternary interface. The ternary interface is selected if LIM1.DRS is reset.
- Digital dual-rail signals received on ports RDIP and RDIN. The dual-rail interface is selected if LIM1.DRS and FMR0.RC1 is set.
- Unipolar data on port ROID received from a fiber-optical interface. The optical interface is selected if LIM1.DRS is set and FMR0.RC1 is reset.

4.1.2 Receive Short and Long-Haul Interface

The FALC56 has an integrated short-haul and long-haul line interface, including a receive equalization network and noise filtering.

4.1.3 Receive Equalization Network (E1)

The FALC56 automatically recovers the signals received on pins RL1/2 in a range of up to -43 dB. The maximum reachable length with a 22 AWG twisted pair cable is 1500 m. After reset the FALC56 is in short-haul mode, received signals are recovered up to -10 dB of cable attenuation. Switching in Long-haul mode is done by setting of bit LIM0.EQON.

The integrated receive equalization network recovers signals with up to -43 dB of cable attenuation. Noise filters eliminate the higher frequency part of the received signals. The incoming data is peak-detected and sliced to produce the digital data stream. The slicing level is software selectable in four steps (45%, 50%, 55%, 67%). For typical E1 applications, a level of 50% is used. The received data is then forwarded to the clock & data recovery unit.

In long-haul mode, the current equalizer status is indicated by register RES (Receive Equalizer Status).

4.1.4 Receive Line Attenuation Indication (E1)

Status register RES reports the current receive line attenuation in a range from 0 to -43 dB in 25 steps of approximately 1.7 dB each. The least significant 5 bits of this register indicate the cable attenuation in dB. These 5 bits are only valid in combination with the most significant two bits (RES.EV1/0 = 01).

4.1.5 Receive Clock and Data Recovery (E1)

The analog received signal on port RL1/2 is equalized and then peak-detected to produce a digital signal. The digital received signal on port RDIP/N is directly forwarded to the DPLL. The receive clock and data recovery extracts the route clock from the data stream received at the RL1/2, RDIP/RDIN or ROID lines and converts the data stream into a single-rail, unipolar bit stream. The clock and data recovery uses an internally generated high frequency clock based on MCLK.

The recovered route clock or a de-jittered clock can be output on pin RCLK as shown in [Table 10](#).

See also [Table 13](#) on page [67](#) for details of master/slave clocking.

Table 10 RCLK Output Selection (E1)

Clock Source	RCLK Frequency	CMR1. DCS	CMR1. RS1/0
Receive Data (2.048 Mbit/s on RL1/RL2, RDIP/ RDIN or ROID)	2.048 MHz (recovered clock)	X	00
Receive Data in case of LOS	constant high	0	01
	2.048 MHz (generated by DCO-R, synchronized on SYNC)	1	10
DCO-R	2.048 MHz	X	10
	8.192 MHz	X	11

The intrinsic jitter generated in the absence of any input jitter is not more than 0.035 UI. In digital bipolar line interface mode the clock and data recovery requires HDB3 coded signals with 50% duty cycle.

4.1.6 Receive Line Coding (E1)

The HDB3 line code or the AMI coding is provided for the data received from the ternary or the dual-rail interface. In case of the optical interface a selection between the NRZ code and the CMI Code (1T2B) with HDB3 or AMI postprocessing is provided. If CMI code is selected the receive route clock is recovered from the data stream. The CMI decoder does not correct any errors. In case of NRZ coding data is latched with the falling edge of signal RCLKI. The HDB3 code is used along with double violation detection or extended code violation detection (selectable by FMR0.EXZE)). In AMI code all code violations are detected. The detected errors increment the code violation counter (16 bits length).

When using the optical interface with NRZ coding, the decoder is bypassed and no code violations are detected.

The signal at the ternary interface is received at both ends of a transformer.

The E1 operating modes 75 Ω or 120 Ω are selectable by switching resistors in parallel or using special transformers with different transfer ratios in one package (using center tap). This selection does not require changing transformers.

Functional Description E1

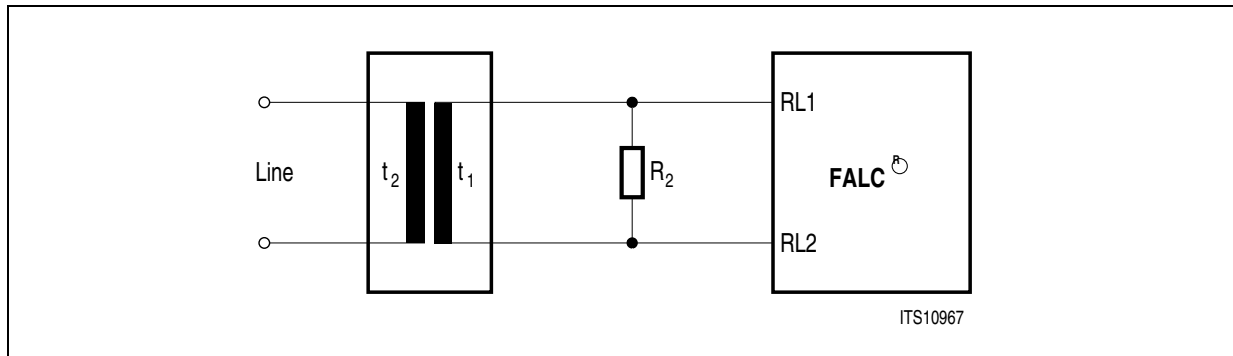

Figure 14 Receiver Configuration (E1)

Table 11 Recommended Receiver Configuration Values (E1)

Parameter ¹⁾	Characteristic Impedance [Ω]	
	120	75
R_2 ($\pm 1\%$) [Ω]	120	75
$t_2 : t_1$	1 : 1	1 : 1

¹⁾ This includes all parasitic effects caused by circuit board design.

4.1.7 Receive Line Monitoring Mode

For short-haul applications like shown in [Figure 15](#), the receive equalizer can be switched into receive line monitoring mode ($LIM0.RLM = 1$). One device is used as a short-haul receiver while the other is used as a short-haul monitor. In this mode the receiver sensitivity is increased to detect an incoming signal of -20 dB resistive attenuation. The required resistor values are given in [Table 12](#).

Functional Description E1

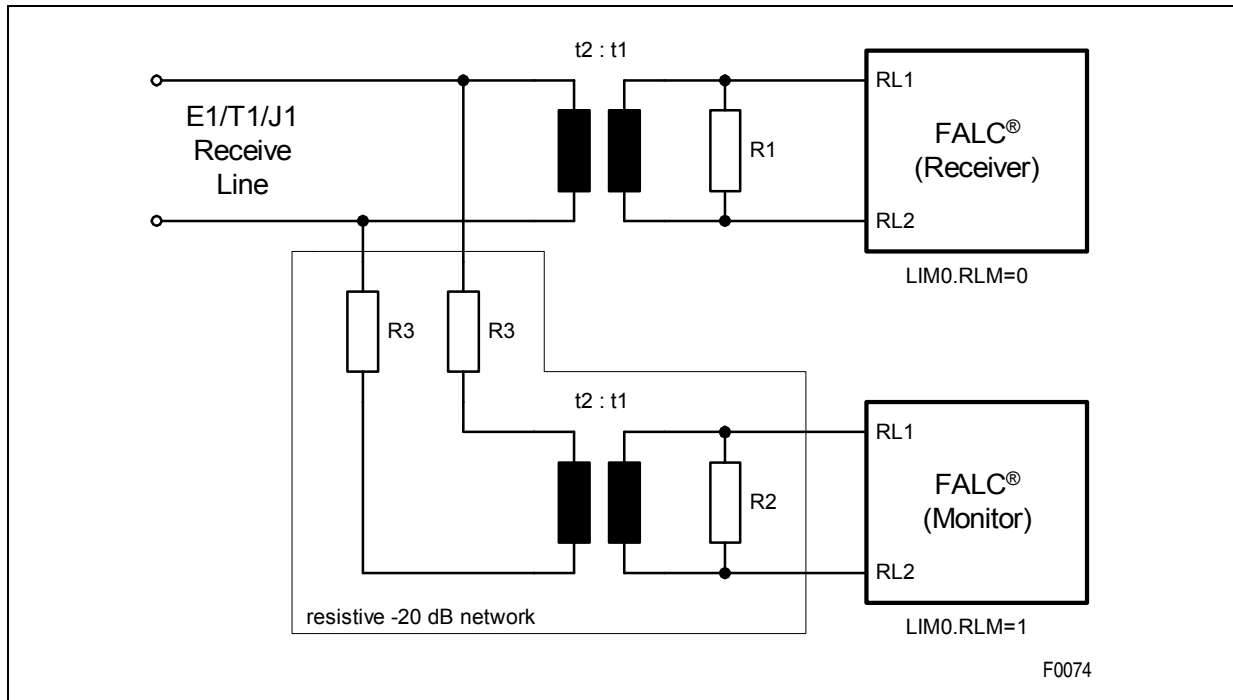

Figure 15 Receive Line Monitoring

Table 12 External Component Recommendations (Monitoring)

Parameter ¹⁾	Characteristic Impedance [Ω]	
	E1	
	75	120
$R_1 (\pm 1 \%) [\Omega]$	75	120
$R_2 (\pm 1 \%) [\Omega]$	75	120
$R_3 (\pm 1 \%) [\Omega]$	330	510
$t_2 : t_1$	1 : 1	1 : 1

¹⁾ This includes all parasitic effects caused by circuit board design.

Using the receive line monitor mode and the hardware tristate function of transmit lines XL1/2, the FALC56 now supports applications connecting two devices to one receive and transmission line. In these kind of applications both devices are working in parallel for redundancy purpose (see [Figure 16](#)). While one of them is driving the line, the other one must be switched into transmit line tristate mode. If both channels are configured identically and supplied with the same system data and clocks, the transmit path can be switched from one channel to the other without causing a synchronization loss at the remote end.

Functional Description E1

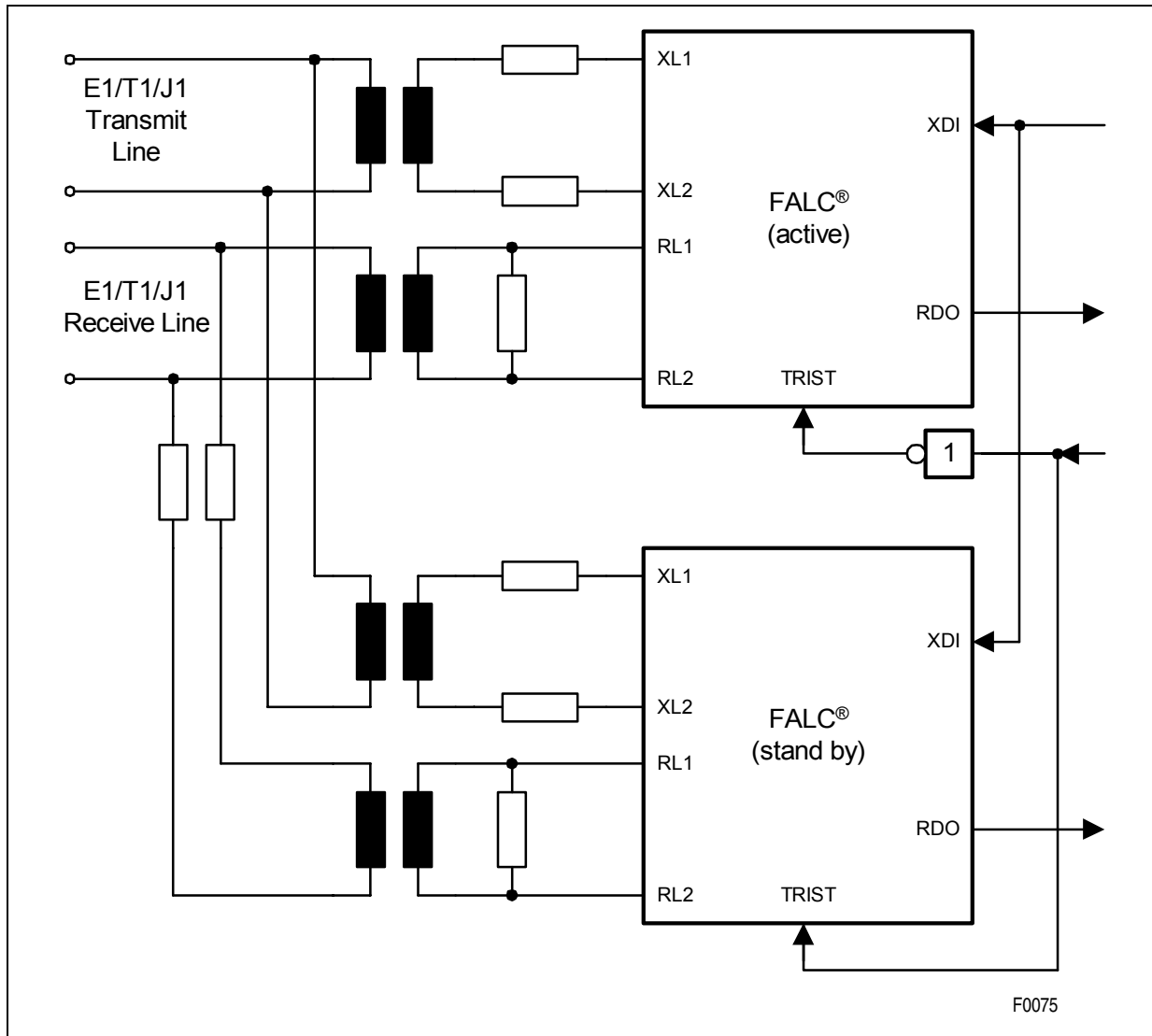

Figure 16 Protection Switching Application

4.1.8 Loss-of-Signal Detection (E1)

There are different definitions for detecting Loss-Of-Signal (LOS) alarms in the ITU-T G.775 and ETS 300233. The FALC56 covers all these standards. The LOS indication is performed by generating an interrupt (if not masked) and activating a status bit. Additionally a LOS status change interrupt is programmable by using register GCR.SCI.

- Detection:

An alarm is generated if the incoming data stream has no pulses (no transitions) for a certain number (N) of consecutive pulse periods. “No pulse” in the digital receive interface means a logical zero on pins RDIP/RDIN/ROID. A pulse with an amplitude less than Q dB below nominal is the criteria for “no pulse” in the analog receive interface (LIM1.DRS = 0). The receive signal level Q is programmable by three control

Functional Description E1

bits LIM1.RIL(2:0) (see [Chapter 11.3](#) on page 447). The number N can be set by an 8-bit register (PCD). The contents of the PCD register is multiplied by 16, which results in the number of pulse periods, i.e. the time which has to suspend until the alarm has to be detected. The programmable range is 16 to 4096 pulse periods. ETS300233 requires detection intervals of at least 1 ms. This time period results always in a LFA (Loss of Frame Alignment) before a LOS is detected.

- Recovery:

In general the recovery procedure starts after detecting a logical one (digital receive interface) or a pulse (analog receive interface) with an amplitude more than Q dB (defined by LIM1.RIL(2:0)) of the nominal pulse. The value in the 8-bit register PCR defines the number of pulses (1 to 255) to clear the LOS alarm.

If a loss-of-signal condition is detected in long-haul mode, the data stream can optionally be cleared automatically to avoid bit errors before LOS is indicated. The selection is done by LIM1.CLOS = 1.

4.1.9 Receive Jitter Attenuator (E1)

The receive jitter attenuator is placed in the receive path. The working clock is an internally generated high frequency clock based on the clock provided on pin MCLK. The jitter attenuator meets the requirements of ITU-T I.431, G. 736 to 739, G.823 and ETSI TBR12/13.

The internal PLL circuitry DCO-R generates a "jitter-free" output clock which is directly dependent on the phase difference of the incoming clock and the jitter attenuated clock. The receive jitter attenuator can be synchronized either on the extracted receive clock RCLK or on a 2.048-MHz/8-kHz clock provided on pin SYNC (8 kHz in master mode only). The received data is written into the receive elastic buffer with RCLK and are read out with the de-jittered clock sourced by DCO-R. The jitter attenuated clock can be output on pins RCLK, CLK1 or SCLKR. Optionally an 8-kHz clock is provided on pin SEC/FSC.

The DCO-R circuitry attenuates the incoming jittered clock starting at 2-Hz jitter frequency with 20 dB per decade fall-off. Wander with a jitter frequency below 2 Hz is passed unattenuated. The intrinsic jitter in the absence of any input jitter is < 0.02 UI.

For some applications it might be useful starting of jitter attenuation at lower frequencies. Therefore the corner frequency is switchable by the factor of ten down to 0.2 Hz (LIM2.SCF).

The DCO-R circuitry is automatically centered to the nominal bit rate if the reference clock on pin SYNC/RCLK is missed for 2, 3 or 4 of the 2.048-MHz clock periods. This center function of DCO-R can be disabled (CMR2.DCF = 1) in order to accept a gapped reference clock. In analog line interface mode RCLK is always running. Only in digital line interface mode with single-rail data a gapped clock can occur.

The receive jitter attenuator works in two different modes:

Functional Description E1

- **Slave mode**
In slave mode (LIM0.MAS = 0) the DCO-R is synchronized on the recovered route clock. In case of LOS the DCO-R switches automatically to Master mode. If bit CMR1.DCS is set automatic switching from RCLK to SYNC is disabled.
- **Master mode**
In master mode (LIM0.MAS = 1) the jitter attenuator is in free running mode if no clock is supplied on pin SYNC. If an external clock on the SYNC input is applied, the DCO-R synchronizes to this input. The external frequency can be 2.048 MHz (IPC.SSYF = 0) or 8.0 kHz (IPC.SSYF = 1).

The following table shows the clock modes with the corresponding synchronization sources.

Table 13 System Clocking (E1)

Mode	Internal LOS Active	SYNC Input	System Clocks generated by DCO-R
Master	independent	Fixed to V_{DD}	DCO-R centered, if CMR2.DCF = 0. (CMR2.DCF should not be set)
Master	independent	2.048 MHz	Synchronized to SYNC input (external 2.048 MHz, IPC.SSYF = 0)
Master	independent	8.0 kHz	Synchronized to SYNC input (external 8.0 kHz, IPC.SSYF = 1, CMR2.DCF = 0)
Slave	no	Fixed to V_{DD}	Synchronized to line RCLK
Slave	no	2.048 MHz	Synchronized to line RCLK
Slave	yes	Fixed to V_{DD}	CMR1.DCS = 0: DCO-R is centered, if CMR2.DCF = 0. (CMR2.DCF should not be set)
			CMR1.DCS = 1: Synchronized on line RCLK
Slave	yes	2.048 MHz	CMR1.DCS = 0: Synchronized to SYNC input (external 2.048 MHz)
			CMR1.DCS = 1: Synchronized on line clock RCLK

The jitter attenuator meets the jitter transfer requirements of the ITU-T I.431 and G.735 to 739 (refer to [Figure 17](#))

Functional Description E1

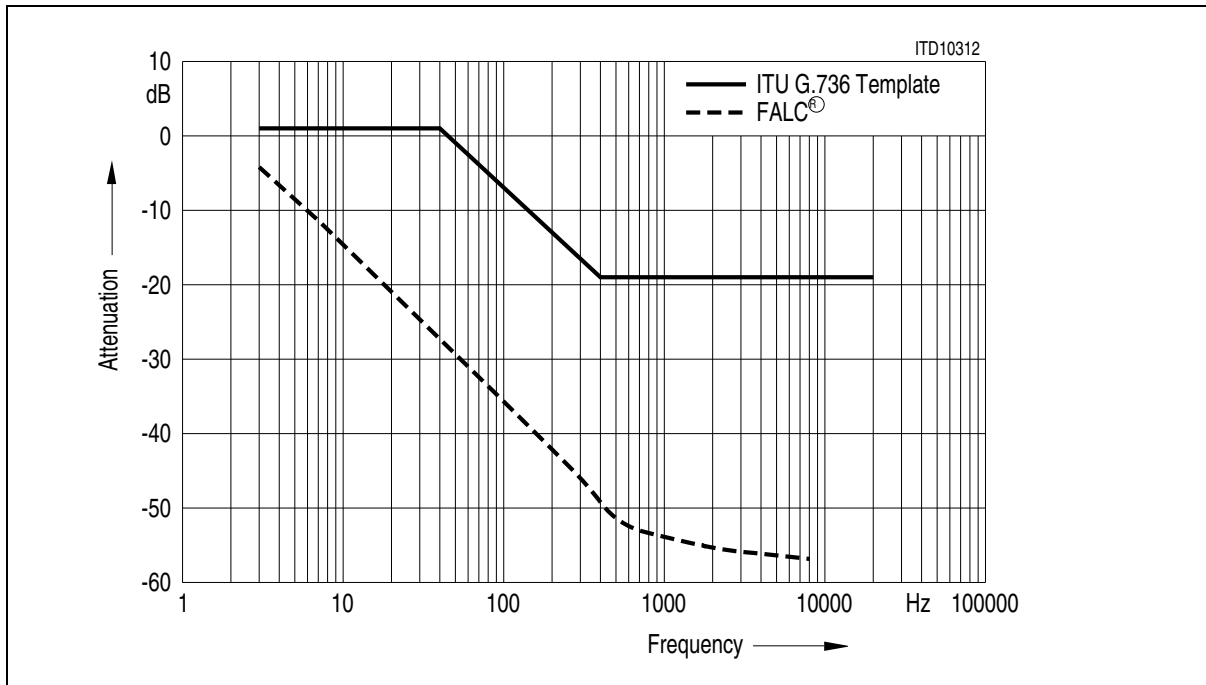

Figure 17 Jitter Attenuation Performance (E1)

Also the requirements of ETSI TBR12/13 are satisfied. Insuring adequate margin against TBR12/13 output jitter limit with 15 UI input at 20 Hz the DCO-R circuitry starts jitter attenuation at about 2 Hz.

4.1.10 Jitter Tolerance (E1)

The FALC56 receiver's tolerance to input jitter complies with ITU for CEPT applications.

Figure 18 shows the curves of different input jitter specifications stated below as well as the FALC56 performance.

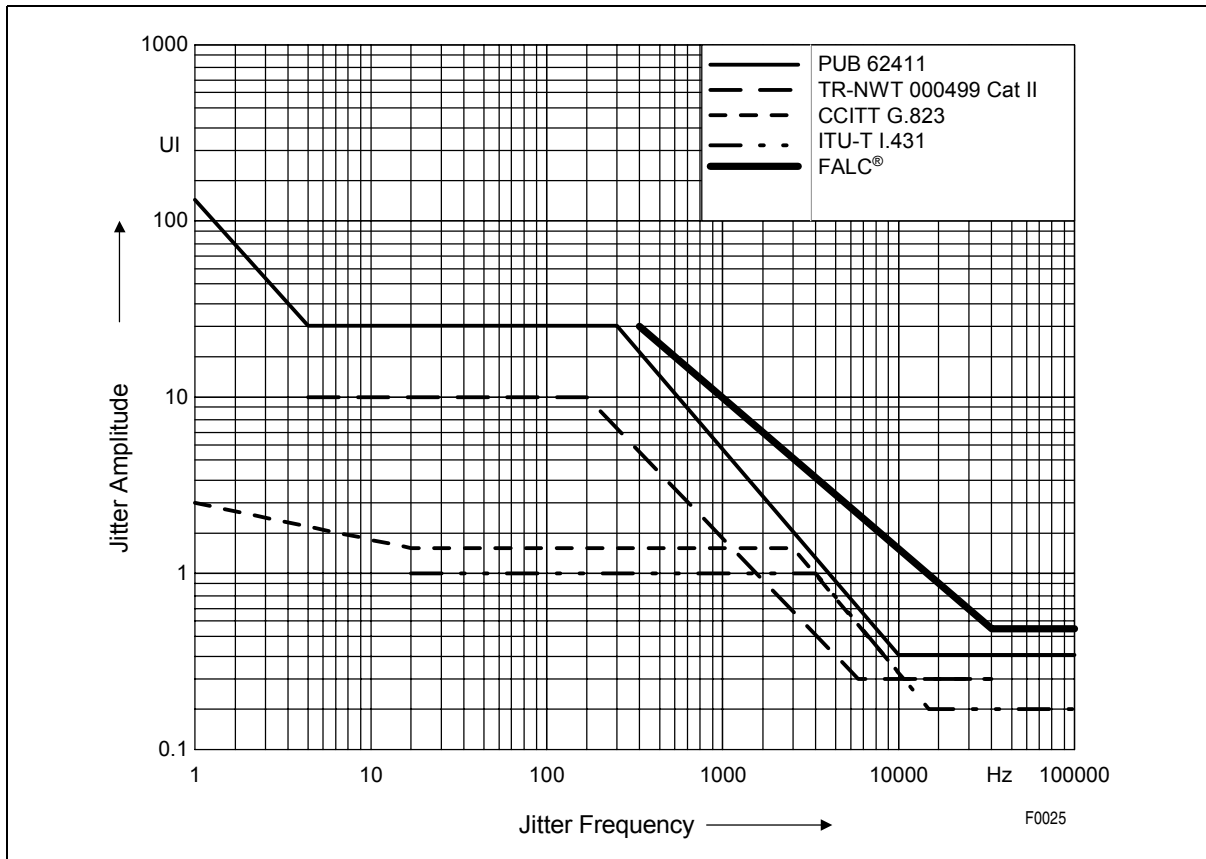

Figure 18 Jitter Tolerance (E1)

4.1.11 Output Jitter (E1)

In the absence of any input jitter the FALC56 generates the output jitter, which is specified in the **Table 14** below.

Table 14 Output Jitter (E1)

Specification	Measurement Filter Bandwidth		Output Jitter (UI peak to peak)
	Lower Cutoff	Upper Cutoff	
ITU-T I.431	20 Hz	100 kHz	< 0.015
	700 Hz	100 kHz	< 0.015
ETSI TBR 12	40 Hz	100 kHz	< 0.11

4.1.12 Framer/Synchronizer (E1)

The following functions are performed:

- Synchronization on pulse frame and multiframe
- Error indication when synchronization is lost. In this case, AIS is sent automatically to the system side and remote alarm is sent to the remote end if enabled.
- Initiating and controlling of resynchronization after reaching the asynchronous state. This can be done automatically by the FALC56 or user controlled using the microprocessor interface.
- Detection of remote alarm indication from the incoming data stream.
- Separation of service bits and data link bits. This information is stored in status registers.
- Generation of various maskable interrupt statuses of the receiver functions.
- Generation of control signals to synchronize the CRC checker, and the receive elastic buffer.

If programmed and applicable to the selected multiframe format, CRC checking of the incoming data stream is done by generating check bits for a CRC submultiframe according to the CRC4 procedure (refer to ITU-T G.704). These bits are compared with those check bits that are received during the next CRC submultiframe. If there is at least one mismatch, the CRC error counter (16 bit) is incremented.

4.1.13 Receive Elastic Buffer (E1)

The received bit stream is stored in the receive elastic buffer. The memory is organized as a two-frame elastic buffer with a maximum size of 64×8 bit. The size of the elastic buffer can be configured independently for the receive and transmit direction. Programming of the receive buffer size is done by SIC1.RBS1/0:

- RBS1/0 = 00: two frame buffer or 512 bits
Maximum of wander amplitude (peak-to-peak): 190 UI (1 UI = 488 ns)
average delay after performing a slip: 1 frame or 256 bits
- RBS1/0 = 01: one frame buffer or 256 bits
Maximum of wander amplitude: 100 UI
average delay after performing a slip: 128 bits, ($\overline{\text{SYPR}}$ = output)
- RBS1/0 = 10: short buffer or 96 bits
Maximum of wander amplitude: 38 UI
average delay after performing a slip: 48 bits, ($\overline{\text{SYPR}}$ = output)
- RBS1/0 = 11: Bypass of the receive elastic buffer

The functions are:

- Clock adaption between system clock (SCLKR) and internally generated route clock (RCLK).
- Compensation of input wander and jitter.

Functional Description E1

- Frame alignment between system frame and receive route frame
- Reporting and controlling of slips

Controlled by special signals generated by the receiver, the unipolar bit stream is converted into bit-parallel data which is circularly written to the elastic buffer using internally generated receive route clock (RCLK).

Reading of stored data is controlled by the system clock sourced by SCLKR or by the receive jitter attenuator and the synchronization pulse (SYPR) together with the programmed offset values for the receive time slot/clock slot counters. After conversion into a serial data stream, the data is given out on port RDO. If the receive buffer is bypassed programming of the time slot offset is disabled and data is clocked off with RCLK instead of SCLKR.

In one frame or short buffer mode the delay through the receive buffer is reduced to an average delay of 128 or 46 bits. In bypass mode the time slot assigner is disabled. In this case SYPR programmed as input is ignored. Slips are performed in all buffer modes except the bypass mode. After a slip is detected the read pointer is adjusted to one half of the current buffer size.

The following table gives an overview of the receive buffer operating mode.

Table 15 Receive Buffer Operating Modes (E1)

Buffer Size (SIC1.RBS1/0)	TS Offset programming (RC1/0) + SYPR = input	Slip performance
bypass ¹⁾	disabled recommended: SYPR = output	no
short buffer	not recommended, recommended: SYPR = output	yes
1 frame	not recommended, recommended: SYPR = output	yes
2 frames	enabled	yes

¹⁾ In bypass mode the clock provided on pin SCLKR is ignored. Clocking is done with RCLK.

In single frame mode (SIC1.RBS), values of receive time slot offset (RC1/0) have to be specified great enough to prevent too great approach of frame begin of line side and frame begin of system side.

Figure 19 gives an idea of operation of the receive elastic buffer:

A slip condition is detected when the write pointer (W) and the read pointer (R) of the memory are nearly coincident, i.e. the read pointer is within the slip limits (S +, S -). If a

Functional Description E1

slip condition is detected, a negative slip (one frame or one half of the current buffer size is skipped) or a positive slip (one frame or one half of the current buffer size is read out twice) is performed at the system interface, depending on the difference between RCLK and the current working clock of the receive backplane interface. I.e. on the position of pointer R and W within the memory. A positive/negative slip is indicated in the interrupt status bits ISR3.RSP and ISR3.RSN.

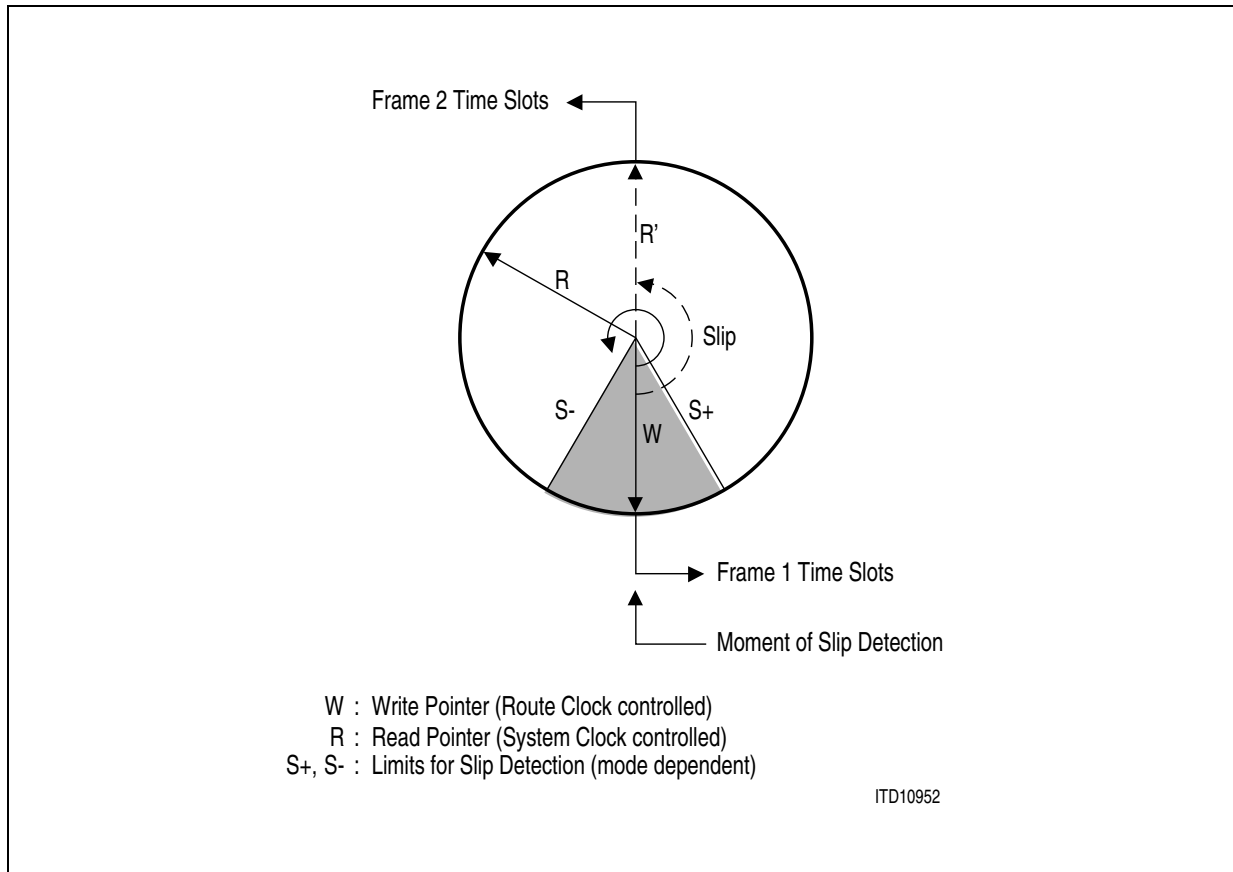

Figure 19 The Receive Elastic Buffer as Circularly Organized Memory

4.1.14 Receive Signaling Controller (E1)

The signaling controller can be programmed to operate in various signaling modes. The FALC56 performs the following signaling and data link methods.

4.1.14.1 HDLC or LAPD access

The FALC56 offers three independent HDLC channels. All of them provide the following features:

- 64 byte receive FIFO for each channel
- 64 byte transmit FIFO for each channel
- transmission in one of 31 time slots
(time slot number programmable for each channel individually)
- transmission in even frames only, odd frames only or both
(programmable for each channel individually)
- bit positions to be used in selected time slots are maskable
(any bit position can be enabled for each channel individually)
- HDLC or transparent mode
- flag detection
- CRC checking
- bit-stuffing
- flexible address recognition (1 byte, 2 bytes)
- C/R-bit processing (according to LAPD protocol)

In addition to this, HDLC channel 1 provides:

- SS7 support
- BOM (bit oriented message) support
- use of time slot 0 (up to 32 time slots)
- use of S_a -bits
- flexibility to insert and extract data during certain time slots, any combination of time slots can be programmed independently for the receive and transmit direction

In case of common channel signaling the signaling procedure HDLC/SDLC or LAPD according to Q.921 is supported. The signaling controller of the FALC56 performs the flag detection, CRC checking, address comparison and zero-bit removing. The received data flow and the address recognition features can be performed in very flexible way, to satisfy almost any practical requirements. Depending on the selected address mode, the FALC56 performs a 1 or 2-byte address recognition. If a 2-byte address field is selected, the high address byte is compared with the fixed value FEH or FCH (group address) as well as with two individually programmable values in RAH1 and RAH2 registers. According to the ISDN LAPD protocol, bit 1 of the high byte address is interpreted as command/response bit (C/R) and is excluded from the address comparison. Buffering of receive data is done in a 64 byte deep RFIFO.

Functional Description E1

In signaling controller transparent mode, fully transparent data reception without HDLC framing is performed, i.e. without flag recognition, CRC checking or bit stuffing. This allows user specific protocol variations.

4.1.14.2 Support of Signaling System #7

The HDLC controller of channel 1 supports the signaling system #7 (SS7) which is described in ITU-Q.703. The following description assumes, that the reader is familiar with the SS7 protocol definition.

SS7 support must be activated by setting the MODE register. The SS7 protocol is supported by the following hardware features in receive mode:

- all Signaling Units (SU) are stored in the receive FIFO (RFIFO)
- detecting of flags from the incoming data stream
- bit stuffing (zero deletion)
- checking of seven or more consecutive ones in the receive data stream
- checking if the received Signaling Unit is a multiple of eight bits and at least six octets including the opening flag
- calculation of the CRC16 checksum:
In receive direction the calculated checksum is compared to the received one; errors are reported in register RSIS.
- checking if the signal information field of a received signaling unit consists of more than 272 octets, in this case the current signaling unit is discarded.

In order to reduce the microprocessor load, fill In signaling units (FISUs) are processed automatically. By examining the length indicator of a received signal unit the FALC56 decides whether a FISU has been received. Consecutively received FISUs are compared and optionally not stored in the receive FIFO (RFIFO, 2×32 bytes), if the contents is equal to the previous one. The same applies to link status signaling units, if bit CCR5.CSF is set. The different types of signaling units as message signaling unit (MSU), link status signaling unit (LSSU) and fill in signaling units (FISU) are indicated in the RSIS register, which is automatically added to the RFIFO with each received signaling unit. The complete signaling unit except start and end flags is stored in the receive FIFO. The functions of bits CCR1.RCRC and CCR1.RADD are still valid in SS7 mode. Errored signaling units are handled automatically according to ITU-T Q.703 as shown in **Figure 20**. SU counter (su) and errored SU counter (C_s) are reset by setting CMDR2.RSUC. The error threshold T can be selected to be 64 (default) or 32 by setting/clearing bit CCR5.SUET. If the defined error limit is exceeded, an interrupt (ISR1.SUEX) is generated, if not masked by IMR1.SUEX = 1.

Note: If SUEX is caused by an aborted/invalid frame, the interrupt will be issued regularly until a valid frame is received (e.g. a FISU).

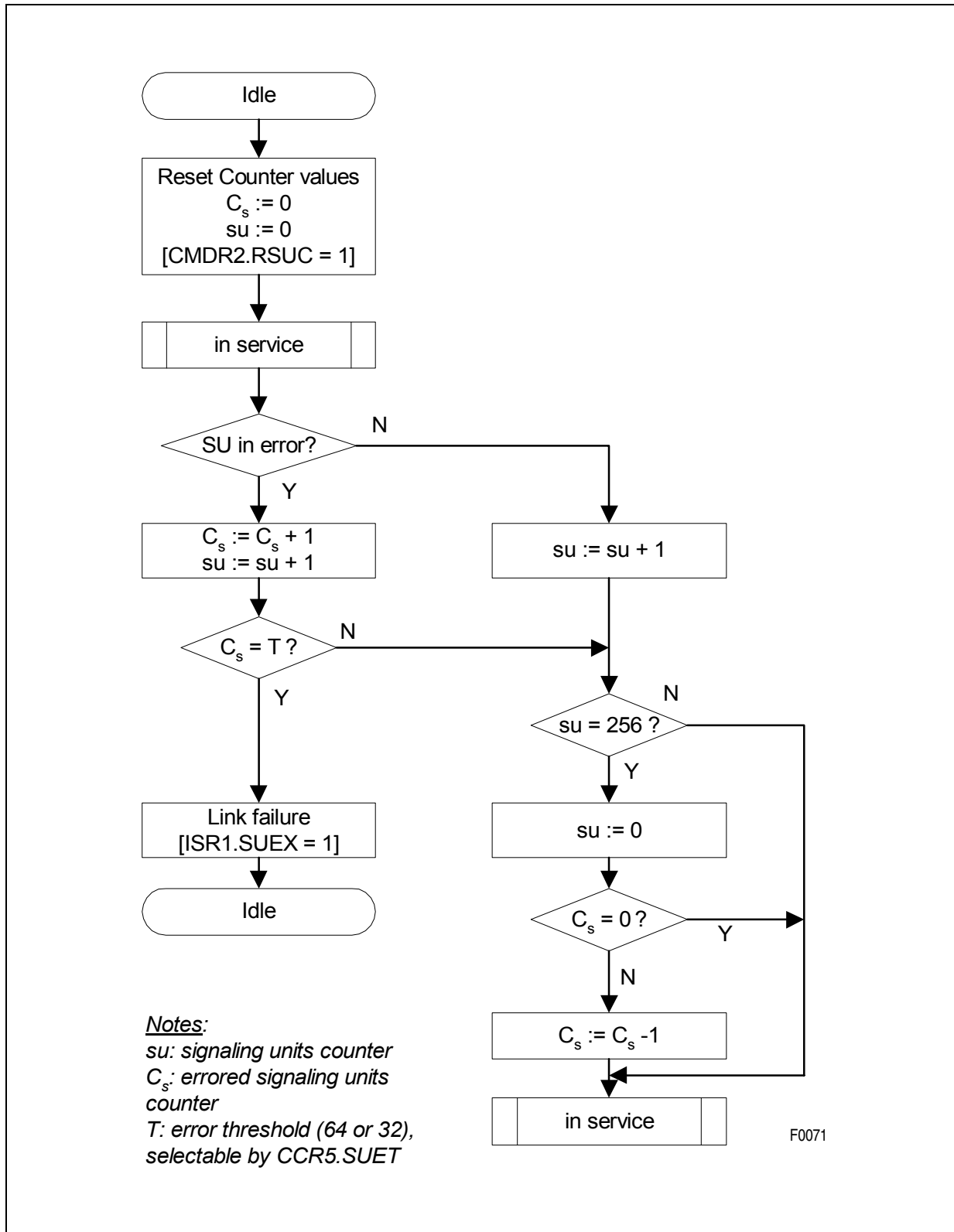

Figure 20 Automatic Handling of Errored Signaling Units

4.1.14.3 S_a-Bit Access (E1)

The FALC56 supports the S_a-bit signaling of time slot 0 of every other frame as follows:

- the access through register RSW
- the access through registers RSA(8:4), capable of storing the information for a complete multiframe
- the access through the 64 byte deep receive FIFO of the signaling controller of HDLC channel 1. This S_a-bit access gives the opportunity to receive a transparent bit stream as well as HDLC frames where the signaling controller automatically processes the HDLC protocol. Any combination of S_a-bits which shall be extracted and stored in the RFIFO is selected by XC0.SA(8:4). The access to the RFIFO is supported by ISR0.RME/RPF.

4.1.14.4 Channel Associated Signaling CAS (E1, serial mode)

The signaling information is carried in time slot 16 (TS16). The signaling controller samples the bit stream either on the receive line side or if external signaling is enabled on the receive system side. External signaling is enabled by selecting the RSIG pin function in registers PC(4:1) and setting XSP.CASEN = 1.

Optionally the complete CAS multiframe can be transmitted on pin RSIG. The signaling data is clocked with the working clock of the receive highway (SCLKR) together with the receive synchronization pulse ($\overline{\text{SYPR}}$). Data on RSIG is transmitted in the last 4 bits per time slot and is aligned to the data on RDO. The first 4 bits per time slot can be optionally fixed high or low (SIC2.SSF), except for time slot 0 and 16 (bit 1 to 4 are always "0000" in TS16). In time slot 0 the FAS/NFAS word is transmitted, in time slot 16 the CAS multiframe pattern "0000XYXX". Data on RSIG is only valid if the freeze signaling status is inactive. With FMR1.SAIS an all-ones data stream can be transmitted on RDO and RSIG.

The signaling procedure is done as it is described in ITU-T G.704 and G.732.

The main functions are:

- Synchronization to a CAS multiframe
- Detection of AIS and remote alarm in CAS multiframe
- Separation of CAS service bits X1 to X3

Updating of the received signaling information is controlled by the freeze signaling status. The freeze signaling status is automatically activated if a loss-of-signal (FRS0.LOS = 1), or a loss of CAS multiframe alignment (FRS1.TSL16LFA = 1) or a receive slip occurs. The current freeze status is output on port FREEZE (RP(A:D)) and indicated by register SIS.SFS. Optionally automatic freeze signaling can be disabled by setting bit SIC3.DAF.

After CAS resynchronization an interrupt is generated. Because at this time the signaling is still frozen, CAS data is not valid yet. Readout of CAS data has to be delayed until the next CAS multiframe is received.

Functional Description E1

Because the CAS controller is working on the PCM highway side of the receive buffer, slips disturb the CAS data.

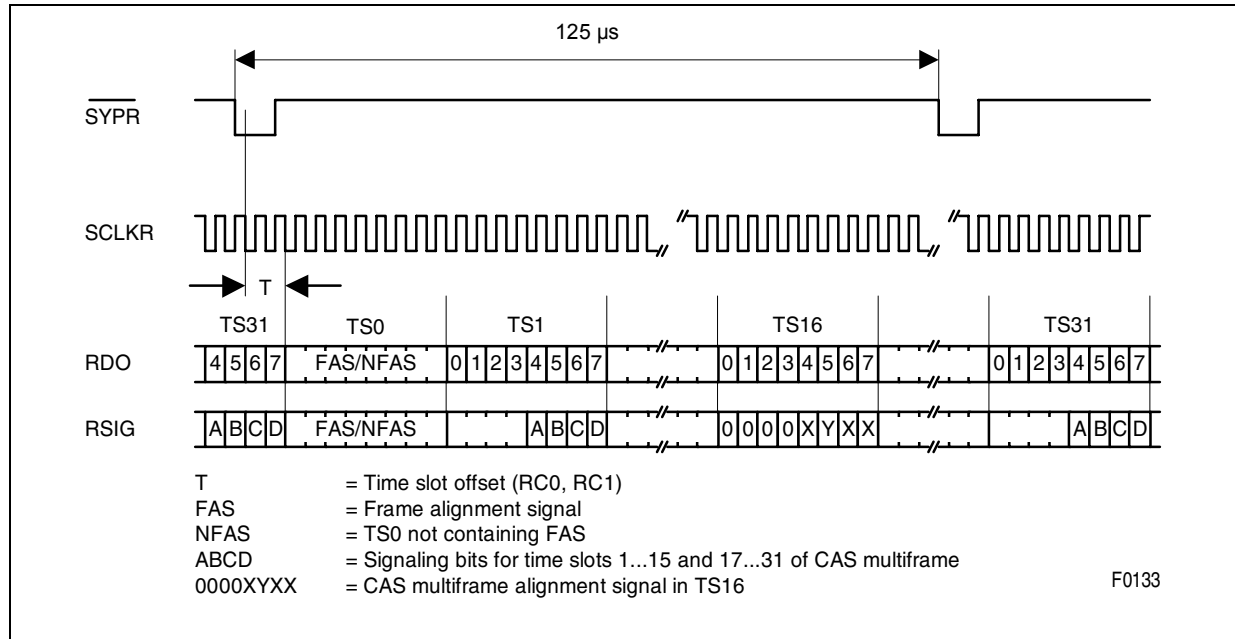

Figure 21 2.048 MHz Receive Signaling Highway (E1)

4.1.14.5 Channel Associated Signaling CAS (E1, µP access mode)

The signaling information is carried in time slot 16 (TS16). Receive data is stored in registers RS(16:1) aligned to the CAS multiframe boundary. The signaling controller samples the bit stream either on the receive line side or if external signaling is enabled on the receive system side.

The signaling procedure is done as it is described in ITU-T G.704 and G.732.

The main functions are:

- Synchronization to a CAS multiframe
- Detection of AIS and remote alarm in CAS multiframes
- Separation of CAS service bits X1 to X3
- Storing of received signaling data in registers RS(16:1) with last look capability

Updating of the received signaling information is controlled by the freeze signaling status. The freeze signaling status is automatically activated if a loss-of-signal (FRS0.LOS = 1), or a loss of CAS multiframe alignment (FRS1.TSL16LFA = 1) or a receive slip occurs. The current freeze status is output on port FREEZE (RP(A:D)) and indicated by register SIS.SFS. Optionally automatic freeze signaling can be disabled by setting bit SIC3.DAF. If SIS.SFS is active, updating of the registers RS(16:1) is disabled.

To relieve the µP load from always reading the complete RS(16:1) buffer every 2 ms the FALC56 notifies the µP through interrupt ISR0.CASC only when signaling changes from

Functional Description E1

one multiframe to the next. Additionally the FALC56 generates a receive signaling data change pointer (RSP1/2) which directly points to the updated RS(16:1) register.

Because the CAS controller is working on the PCM highway side of the receive buffer, slips disturb the CAS data.

4.2 Framer Operating Modes (E1)

4.2.1 General

Bit: FMR1.PMOD = 0

PCM line bit rate	:	2.048 Mbit/s
Single frame length	:	256 bit, No. 1...256
Framing frequency	:	8 kHz
HDLC controller	:	$n \times 64$ kbit/s, $n = 1$ to 32 or $n \times 4$ kbit/s, $n = 1$ to 5
Organization	:	32 time slots, No. 0...31 with 8 bits each, No. 1...8

The operating mode of the FALC56 is selected by programming the carrier data rate and characteristics, line code, multiframe structure, and signaling scheme.

The FALC56 implements all of the standard framing structures for E1 or PCM 30 (CEPT, 2.048 Mbit/s) carriers. The internal HDLC or CAS controller supports all signaling procedures including signaling frame synchronization/synthesis and signaling alarm detection in all framing formats. The time slot assignment from the PCM line to the system highway and vice versa is performed without any changes of numbering (TS0 ↔ TS0, ..., TS31 ↔ TS31).

Summary of E1 Framing Modes

- Doubleframe format according to ITU-T G. 704
- Multiframe format according to ITU-T G. 704
- CRC4 processing according to ITU-T G. 706
- Multiframe format with CRC4 to non CRC4 interworking according to ITU-T G. 706
- Multiframe format with modified CRC4 to non CRC4 interworking
- Multiframe format with CRC4 performance monitoring

After reset, the FALC56 is switched into doubleframe format automatically. Switching between the framing formats is done by programming bits FMR2.RFS1/0 and FMR3.EXTIW for the receiver and FMR1.XFS for the transmitter.

4.2.2 Doubleframe Format (E1)

The framing structure is defined by the contents of time slot 0 (refer to [Table 16](#)).

Table 16 Allocation of Bits 1 to 8 of Time Slot 0 (E1)

Bit	1	2	3	4	5	6	7	8
AlternateNumber								
Frames								
Frame Containing the Frame Alignment Signal	S_i	0	0	1	1	0	1	1
	Note ¹⁾	Frame Alignment Signal						
Frame not Containing the Frame Alignment Signal or Service Word	S_i	1	A	S_{a4}	S_{a5}	S_{a6}	S_{a7}	S_{a8}
	Note ¹⁾	Note ²⁾	Note ³⁾	Note ⁴⁾				

¹⁾ S_i -bits: reserved for international use. If not used, these bits should be fixed to "1". Access to received information through bits RSW.RSI and RSP.RSIF. Transmission is enabled by bits XSW.XSIS and XSP.XSIF.

²⁾ Fixed to "1". Used for synchronization.

³⁾ Remote alarm indication: In undisturbed operation "0"; in alarm condition "1".

⁴⁾ S_a -bits: Reserved for national use. If not used, they should be fixed at "1". Access to received information through bits RSW.RY0...4. Transmission is enabled by bits XSW.XY0...4. HDLC signaling in bits S_a4 to 8 is selectable. As a special extension for double frame format, the S_a -bit registers RSA4 to 8/XSA4 to 8 can be used optionally.

4.2.2.1 Transmit Transparent Modes

In transmit direction, contents of time slot 0 frame alignment signal of the outgoing PCM frame are normally generated by the FALC56. However, transparency for the complete time slot 0 can be achieved by selecting the transparent mode XSP.TT0. With the Transparent Service Word Mask register TSWM the S_i -bits, A-bit and the S_a -bits can be selectively switched through transparently.

Table 17 Transmit Transparent Mode (Doubleframe E1)

Transmit Transparent Source for				
Enabled by	Framing	A-Bit	S _a -Bits	S _i -Bits
–	(int. gen.)	XSW.XRA ²⁾	XSW.XY0...4	XSW.XSIS, XSP.XSIF
XSP.TT0	via pin XDI ¹⁾	via pin XDI	³⁾	via pin XDI
TSWM.TSIF	(int. gen.)	XSW.XRA	via pin XDI	via pin XDI
TSWM.TSIS	(int. gen.)	XSW.XRA	XSW.XY0...4	via pin XDI
TSWM.TRA	(int. gen.)	via pin XDI	XSW.XY0...4	XSW.XSIS, XSP.XSIF
TSWM.TSA(8:4)	(int. gen.)	XSW.XRA	XSW.XY0...4	XSW.XSIS, XSP.XSIF
			via pin XDI	

¹⁾ pin XDI or XSIG or XFIFO buffer (signaling controller)

²⁾ Additionally, automatic transmission of the A-bit is selectable.

³⁾ As a special extension for double frame format, the S_a-bit register can be used optionally.

4.2.2.2 Synchronization Procedure

Synchronization status is reported by bit FRS0.LFA. Framing errors are counted by the Framing Error Counter (FEC). Asynchronous state is reached after detecting 3 or 4 consecutive incorrect FAS words or 3 or 4 consecutive incorrect service words (bit 2 = 0 in time slot 0 of every other frame not containing the frame alignment word), the selection is done by bit RC0.ASY4. Additionally, the service word condition can be disabled. When the framer lost its synchronization an interrupt status bit ISR2.LFA is generated.

In asynchronous state, counting of framing errors and detection of remote alarm is stopped. AIS is automatically sent to the backplane interface (can be disabled by bit FMR2.DAIS).

Further on the updating of the registers RSW, RSP, RSA(8:4), RSA6S and RS(16:1) is halted (remote alarm indication, S_a/S_i-Bit access).

The resynchronization procedure starts automatically after reaching the asynchronous state. Additionally, it can be invoked user controlled by bit FMR0.FRS (force resynchronization, the FAS word detection is interrupted until the framer is in the asynchronous state. After that, resynchronization starts automatically).

Synchronous state is established after detecting:

- a correct FAS word in frame n,
- the presence of the correct service word (bit 2 = 1) in frame n + 1,
- a correct FAS word in frame n + 2.

If the service word in frame n + 1 or the FAS word in frame n + 2 or both are not found searching for the next FAS word starts in frame n + 2 just after the previous frame alignment signal.

Functional Description E1

Reaching the synchronous state causes a frame alignment recovery interrupt status ISR2.FAR if enabled. Undisturbed operation starts with the beginning of the next doubleframe.

4.2.2.3 A-Bit Access

If the FALC56 detects a remote alarm indication in the received data stream the interrupt status bit ISR2.RA is set. With setting of bit XSW.XRA a remote alarm (RAI) is sent to the far end.

By setting FMR2.AXRA the FALC56 automatically transmit the remote alarm bit = 1 in the outgoing data stream if the receiver detects a loss of frame alignment FRS0.LFA = 1. If the receiver is in synchronous state FRS0.LFA = 0 the remote alarm bit is reset.

Note: The A-bit can be processed by the system interface. Setting bit TSWM.TRA enables transparency for the A-bit in transmit direction (refer to [Table 16](#)).

4.2.2.4 S_a-Bit Access

As an extension for access to the S_a-bits through registers RSA(8:4)/XSA(8:4) an option is implemented to allow the usage of internal S_a-bit registers RSA(8:4)/XSA(8:4) in doubleframe format.

This function is enabled by setting FMR1.ENSA = 1 for the transmitter and FMR1.RFS(1:0) = 01 for the receiver. In this case the FALC56 internally works with a 16-frame structure but no CRC multiframe alignment/generation is performed.

Functional Description E1

4.2.3 CRC-Multiframe (E1)

The multiframe structure shown in **Table 18** is enabled by setting bit: FMR2.RFS1/0 for the receiver and FMR1.XFS for the transmitter.

- Multiframe : 2 submultiframes = 2 × 8 frames
- Frame alignment : refer to section Doubleframe Format
- Multiframe alignment : bit 1 of frames 1, 3, 5, 7, 9, 11 with the pattern "001011"
- CRC bits : bit 1 of frames 0, 2, 4, 6, 8, 10, 12, 14
- CRC block size : 2048 bit (length of a submultiframe)
- CRC procedure : CRC4, according to ITU-T G.704 and G.706

Table 18 CRC-Multiframe Structure (E1)

	Sub-Multiframe	Frame Number	Bits 1 to 8 of the Frame							
			1	2	3	4	5	6	7	8
Multiframe	I	0	C ₁	0	0	1	1	0	1	1
		1	0	1	A	S _{a4}	S _{a5}	S _{a61}	S _{a7}	S _{a8}
		2	C ₂	0	0	1	1	0	1	1
		3	0	1	A	S _{a4}	S _{a5}	S _{a62}	S _{a7}	S _{a8}
		4	C ₃	0	0	1	1	0	1	1
		5	1	1	A	S _{a4}	S _{a5}	S _{a63}	S _{a7}	S _{a8}
		6	C ₄	0	0	1	1	0	1	1
		7	0	1	A	S _{a4}	S _{a5}	S _{a64}	S _{a7}	S _{a8}
	II	8	C ₁	0	0	1	1	0	1	1
		9	1	1	A	S _{a4}	S _{a5}	S _{a61}	S _{a7}	S _{a8}
		10	C ₂	0	0	1	1	0	1	1
		11	1	1	A	S _{a4}	S _{a5}	S _{a62}	S _{a7}	S _{a8}
		12	C ₃	0	0	1	1	0	1	1
		13	E*	1	A	S _{a4}	S _{a5}	S _{a63}	S _{a7}	S _{a8}
		14	C ₄	0	0	1	1	0	1	1
15		E*	1	A	S _{a4}	S _{a5}	S _{a64}	S _{a7}	S _{a8}	

E: Spare bits for international use. Access to received information through bits RSP.RS13 and RSP.RS15. Transmission is enabled by bits XSP.XS13 and XSP.XS15. Additionally, automatic transmission for submultiframe error indication is selectable.

S_a: Spare bits for national use. Additionally, S_a-bit access through registers RSA4...8 and XSA4...8 is provided. HDLC-signaling in bits S_{a4} to S_{a8} is selectable.

C₁ ... C₄: Cyclic redundancy check bits.

A: Remote alarm indication. Additionally, automatic transmission of the A-bit is selectable.

Functional Description E1

For transmit direction, contents of time slot 0 are additionally determined by the selected transparent mode.

Table 19 Transmit Transparent Mode (CRC Multiframe E1)

Transmit Transparent Source for				
enabled by	Framing + CRC	A-Bit	S _a -Bits	E-Bits
–	(int. gen.)	XSW.XRA ²⁾	XSW.XY0 ... 4 ³⁾	XSP.XS13/XS15 ⁴⁾
XSP.TT0	via pin XDI ¹⁾	via pin XDI	via pin XDI	via pin XDI
TSWM.TSIF	via pin XDI	XSW.XRA ¹⁾	XSW.XY0 ... 4 ²⁾	(int. generated)
TSWM.TSIS	via pin XDI	XSW.XRA ¹⁾	XSW.XY0 ... 4 ²⁾	via pin XDI
TSWM.TRA	(int. gen.)	via pin XDI	XSW.XY0 ... 4 ²⁾	XSP.XS13/XS15 ³⁾
TSWM.TSA(8:4)	(int. gen.)	XSW.XRA ¹⁾	via pin XDI	XSP.XS13/XS15 ³⁾

¹⁾ pin XDI or XSIG or XFIFO buffer (signaling controller)

²⁾ Automatic transmission of the A-bit is selectable

³⁾ The S_a-bit register XSA(8:4) can be used optionally

⁴⁾ Additionally, automatic transmission of submultiframe error indication is selectable

The CRC procedure is automatically invoked when the multiframe structure is enabled. CRC errors in the received data stream are counted by the 16-bit CRC Error Counter CEC (one error per submultiframe, maximum).

Additionally a CRC4 error interrupt status ISR0.CRC4 is generated if enabled by IMR0.CRC4.

All CRC bits of one outgoing submultiframe are automatically inverted in case a CRC error is flagged for the previous received submultiframe. This function is enabled by bit RC0.CRCI. Setting of bit RC0.XCRCI inverts the CRC bits before transmission to the distant end. The function of RC0.XCRCI and RC0.CRCI are logically ored.

4.2.3.1 Synchronization Procedure

Multiframe alignment is assumed to have been lost if doubleframe alignment has been lost (flagged on status bit FRS0.LFA). The rising edge of this bit causes an interrupt.

The multiframe resynchronization procedure starts when Doubleframe alignment has been regained which is indicated by an interrupt status bit ISR2.FAR. For Doubleframe synchronization refer to section Doubleframe Format. It is also be invoked by the user by setting

- bit FMR0.FRS for complete doubleframe **and** multiframe resynchronization
- bit FMR1.MFCS for multiframe resynchronization only.

The CRC checking mechanism is enabled after the first correct multiframe pattern has been found. However, CRC errors are not counted in asynchronous state.

Functional Description E1

In doubleframe asynchronous state, counting of framing errors, CRC4 bit errors and detection of remote alarm is stopped. AIS is automatically sent to the backplane interface (can be disabled by bit FMR2.DAIS). Further on the updating of the registers RSW, RSP, RSA(8:4), RSA6S and RS(16:1) is halted (remote alarm indication, S_a/S_i -bit access).

The multiframe synchronous state is established after detecting two correct multiframe alignment signals at an interval of $n \times 2$ ms ($n = 1, 2, 3 \dots$). The loss of multiframe alignment flag FRS0.LMFA is reset. Additionally an interrupt status multiframe alignment recovery bit ISR2.MFAR is generated with the falling edge of bit FRS0.LMFA.

4.2.3.2 Automatic Force Resynchronization (E1)

In addition, a search for Doubleframe alignment is automatically initiated if two multiframe pattern with a distance of $n \times 2$ ms have not been found within a time interval of 8 ms after doubleframe alignment has been regained (bit FMR1.AFR). A new search for frame alignment is started just after the previous frame alignment signal.

4.2.3.3 Floating Multiframe Alignment Window (E1)

After reaching doubleframe synchronization a 8 ms timer is started. If a multiframe alignment signal is found during the 8 ms time interval the internal timer is reset to remaining 6 ms in order to find the next multiframe signal within this time. If the multiframe signal is not found for a second time, the interrupt status bit ISR0.T8MS is set. This interrupt usually occurs every 8 ms until multiframe synchronization is achieved.

4.2.3.4 CRC4 Performance Monitoring (E1)

In the synchronous state checking of multiframe pattern is disabled. However, with bit FMR2.ALMF an automatic multiframe resynchronization mode can be activated. If 915 out of 1000 errored CRC submultiframes are found then a false frame alignment is assumed and a search for doubleframe and multiframe pattern is initiated. The new search for frame alignment is started just after the previous basic frame alignment signal. The internal CRC4 resynchronization counter is reset when the multiframe synchronization has been regained.

4.2.3.5 Modified CRC4 Multiframe Alignment Algorithm (E1)

The modified CRC4 multiframe alignment algorithm allows an automatic interworking between framers with and without a CRC4 capability. The interworking is realized as it is described in ITU-T G.706 Appendix B.

If doubleframe synchronization is consistently present but CRC4 multiframe alignment is not achieved within 400 ms it is assumed that the distant end is initialized to doubleframe format. The CRC4/non-CRC4 interworking is enabled by FMR2.RFS1/0 = 11 and is activated only if the receiver has lost its synchronization. If doubleframe alignment (basic

Functional Description E1

frame alignment) is established, a 400 ms timer and searching for multiframe alignment are started. A research for basic frame alignment is initiated if the CRC4 multiframe synchronization cannot be achieved within 8 ms and is started just after the previous frame alignment signal. The research of the basic frame alignment is done in parallel and is independent of the synchronization procedure of the primary basic frame alignment signal. During the parallel search all receiver functions are based on the primary frame alignment signal, like framing errors, S_a -, S_i -, A-bits, ...). All subsequent multiframe searches are associated with each basic framing sequence found during the parallel search.

If the CRC4 multiframe alignment sequence was not found within the time interval of 400 ms, the receiver is switched into a non-CRC4 mode indicated by setting the bit FRS0.NMF (No Multiframe Found) and ISR2.T400MS. In this mode checking of CRC bits is disabled and the received E-bits are forced to low. The transmitter framing format is not changed. Even if multiple basic FAS resynchronizations have been established during the parallel search, the receiver is maintained to the initially determined primary frame alignment signal location.

However, if the CRC4-multiframe alignment can be achieved within the 400 ms time interval assuming a CRC4-to-CRC4 interworking, then the basic frame alignment sequence associated to the CRC4 multiframe alignment signal is chosen. If necessary, the primary frame alignment signal location is adjusted according to the multiframe alignment signal. The CRC4 performance monitoring is started if enabled by FMR2.ALMF and the received E-bits are processed in accordance to ITU-T G.704.

Switching into the doubleframe format (non-CRC4) mode after 400 ms can be disabled by setting of FMR3.EXTIW. In this mode the FALC56 continues to search for multiframing. In the interworking mode setting of bit FMR1.AFR is not allowed.

4.2.3.6 A-Bit Access (E1)

If the FALC56 detects a remote alarm indication (bit 2 in TS0 not containing the FAS word) in the received data stream the interrupt status bit ISR2.RA is set. With the deactivation of the remote alarm the interrupt status bit ISR2.RAR is generated.

By setting FMR2.AXRA the FALC56 automatically transmits the remote alarm bit = 1 in the outgoing data stream if the receiver detects a loss of frame alignment (FRS0.LFA = 1). If the receiver is in synchronous state (FRS0.LFA = 0), the remote alarm bit is reset in the outgoing data stream.

Additionally, if bit FMR3.EXTIW is set and the multiframe synchronous state cannot be achieved within 400 ms after finding the primary basic framing, the A-bit is transmitted active high to the remote end until the multiframing is found.

Note: The A-bit can be processed by the system interface. Setting bit TSWM.TRA enables transparency for the A-bit in transmit direction (refer to [Table 18](#)).

4.2.3.7 S_a -Bit Access (E1)

Due to signaling procedures using the five S_a -bits ($S_{a4} \dots S_{a8}$) of every other frame of the CRC multiframe structure, three possibilities of access by the microprocessor are implemented.

- The standard procedure allows reading/writing the S_a -bit registers RSW, XSW without further support. The S_a -bit information is updated every other frame.
- The advanced procedure, enabled by bit FMR1.ENSA, allows reading/writing the S_a -bit registers RSA4...8, XSA4...8.

A transmit or receive multiframe begin interrupt (ISR0.RMB or ISR1.XMB) is provided.

Registers RSA(8:4) contains the service word information of the previously received CRC-multiframe or 8 doubleframes (bit slots 4 to 8 of every service word). These registers are updated with every multiframe begin interrupt ISR0.RMB.

With the transmit multiframe begin an interrupt ISR1.XMB is generated and the contents of the registers XSA(8:4) is copied into shadow registers. The contents is subsequently sent out in the service words of the next outgoing CRC multiframe (or every doubleframe) if none of the time slot 0 transparent modes is enabled. The transmit multiframe begin interrupt XMB request that these registers issue should be serviced. If requests for new information are ignored, the current contents is repeated.

- The extended access through the receive and transmit FIFOs of the signaling controller. In this mode it is possible to transmit/receive a HDLC frame or a transparent bit stream in any combination of the S_a -bits. Enabling is done by setting of bit CCR1.EITS and the corresponding bits XC0.SA8E to SA4E/TSWM.TSA8 to TSA4 and resetting of registers TTR(4:1), RTR(4:1) and FMR1.ENSA. The access to and from the FIFOs is supported by ISR0.RME, RPF and ISR1.XPR, ALS.

S_a 6-Bit Detection according to ETS 300233

Four consecutive received S_a 6-bits are checked for the combinations defined by ETS 300233. The FALC56 detects the following fixed S_a 6-bit combinations: SA61, SA62, SA63, SA64 = 1000, 1010, 1100, 1110, 1111. All other possible 4-bit combinations are grouped to status "X".

A valid S_a 6-bit combination must occur three times in a row. The corresponding status bit in register RSA6S is set. Register RSA6S is of type "clear on read". Any status change of the S_a 6-bit combinations causes an interrupt (ISR0.SA6SC).

During the basic frame asynchronous state update of register RSA6S and interrupt status ISR0.SA6SC is disabled. In multiframe format the detection of the S_a 6-bit combinations can be done either synchronously or asynchronously to the submultiframe (FMR3.SA6SY). In synchronous detection mode updating of register RSA6S is done in the multiframe synchronous state (FRS0.LMFA = 0). In asynchronous detection mode updating is independent of the multiframe synchronous state.

S_a6-Bit Error Indication Counters

The S_a6-bit error indication counter CRC2L/H (16 bits) counts the received S_a6-bit sequence 0001 or 0011 in every CRC submultiframe. In the primary rate access digital section this counter option gives information about CRC errors reported from the TE by the S_a6 bit. Incrementing is only possible in the multiframe synchronous state. The S_a6-bit error indication counter CRC3L/H (16 bits) counts the received S_a6-bit sequence 0010 or 0011 in every CRC submultiframe. In the primary rate access digital section this counter option gives information about CRC errors detected at T-reference point and reporting them by the S_a6-bit. Incrementing is only possible in the multiframe synchronous state.

4.2.3.8 E-Bit Access (E1)

Due to signaling requirements, the E-bits of frame 13 and frame 15 of the CRC multiframe can be used to indicate received errored submultiframes:

Submultiframe I statusE-bit located in frame 13

Submultiframe II statusE-bit located in frame 15

no CRC error: E = 1; CRC error: E = 0

Standard Procedure

After reading the submultiframe error indication RSP.SI1 and RSP.SI2, the microprocessor has to update the contents of register XSP (XS13, XS15). Access to these registers has to be synchronized on transmit or receive multiframe begin interrupts (ISR0.RMB or ISR1.XMB).

Automatic Mode

In the multiframe synchronous state the E-bits are processed according to ITU-T G.704 independently of bit XSP.EBP (E-bit polarity selection).

By setting bit XSP.AXS status information of received submultiframes is automatically inserted in the E-bit position of the outgoing CRC multiframe without any further interventions of the microprocessor.

In the doubleframe and multiframe asynchronous state the E-bits are set or cleared, depending on the setting of bit XSP.EBP.

Submultiframe Error Indication Counter

The EBC (E-Bit) counter EBCL/H (16 bits) counts zeros in the E-bit position of frame 13 and 15 of every received CRC multiframe. This counter option gives information about the outgoing transmit PCM line if the E-bits are used by the remote end for submultiframe error indication. Incrementing is only possible in the multiframe synchronous state.

Functional Description E1

Note: E-bits can be processed by the system interface. Setting bit TSWM.TSIS enables transparency for E-bits in transmit direction (refer to [Table 18](#)).

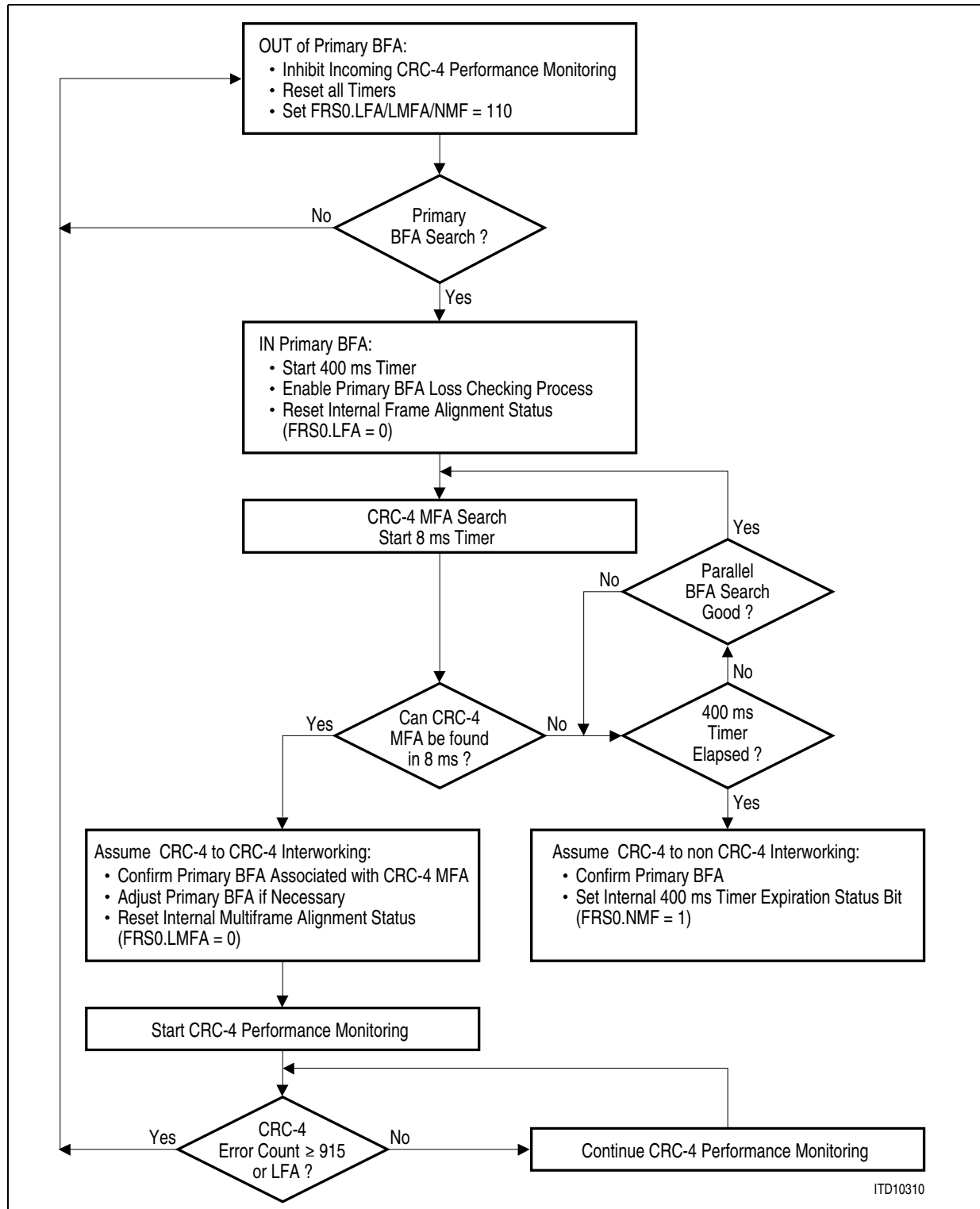

Figure 22 CRC4 Multiframe Alignment Recovery Algorithms (E1)

4.3 Additional Receive Framer Functions (E1)

4.3.1 Error Performance Monitoring and Alarm Handling

Alarm Indication Signal: Detection and recovery is flagged by bit FRS0.AIS and ISR2.AIS. Transmission is enabled by bit FMR1.XAIS.

Loss-Of-Signal: Detection and recovery is flagged by bit FRS0.LOS and ISR2.LOS.

Remote Alarm Indication: Detection and release is flagged by bit FRS0.RRA, RSW.RRA and ISR2.RA/RAR. Transmission is enabled by bit XSW.XRA.

AIS in time slot 16: Detection and release is flagged by bit FRS1.TS16AIS and ISR3.AIS16. Transmission is enabled by writing all ones in registers XS(16:1).

LOS in time slot 16: Detection and release is flagged by bit FRS1.TS16LOS. Transmission is enabled by writing all zeros in registers XS(16:1).

Remote Alarm in time slot 16: Detection and release is flagged by bit FRS1.TS16RA and ISR3.RA16. Transmission is enabled by bit XS1.2.

Transmit Line Shorted: Detection and release is flagged by bit FRS1.XLS and ISR1.XLSC.

Transmit Ones-Density: Detection and release is flagged by bit FRS1.XLO and ISR1.XLSC.

Table 20 Summary of Alarm Detection and Release (E1)

Alarm	Detection Condition	Clear Condition
Loss-Of-Signal (LOS)	no transitions (logical zeros) in a programmable time interval of 16 to 4096 consecutive pulse periods. Programmable receive input signal threshold	programmable number of ones (1 to 256) in a programmable time interval of 16 to 4096 consecutive pulse periods. A one is a signal with a level above the programmed threshold.
Alarm Indication Signal (AIS)	FMR0.ALM = 0: less than 3 zeros in 250 μ s and loss of frame alignment declared FMR0.ALM = 1: less than 3 zeros in each of two consecutive 250- μ s periods	FMR0.ALM = 0: more than 2 zeros in 250 μ s FMR0.ALM = 1: more than 2 zeros in each of two 500- μ s periods
Remote Alarm (RRA)	bit 3 = 1 in time slot 0 not containing the FAS word	set conditions no longer detected.

Functional Description E1

Table 20 Summary of Alarm Detection and Release (E1) (cont'd)

Alarm	Detection Condition	Clear Condition
Remote Alarm in time slot 16 (TS16RA)	Y-bit = 1 received in CAS multiframe alignment word	Y-bit = 0 received in CAS multiframe alignment word
Loss-of-Signal in time slot 16 (TS16LOS)	all zeros for at least 16 consecutively received time slots 16	receiving a one in time slot 16
Alarm Indication Signal in time slot 16 (TS16AIS)	time slot 16 containing less than 4 zeros in each of two consecutive CAS multiframes periods	time slot 16 containing more than 3 zeros in one CAS multiframe
Transmit Line Short (XLS)	more than 3 pulse periods with highly increased transmit line current on XL1/2	transmit line current limiter inactive
Transmit Ones-Density (XLO)	32 consecutive zeros in the transmit data stream on XL1/2	Cleared with each transmitted pulse

4.3.2 Auto Modes

- Automatic remote alarm access
If the receiver has lost its synchronization a remote alarm can be sent automatically, if enabled by bit FMR2.AXRA to the distant end. The remote alarm bit is set automatically in the outgoing data stream, if the receiver is in asynchronous state (FRS0.LFA bit is set). In synchronous state the remote alarm bit is removed.
- Automatic E-bit access
By setting bit XSP.AXS status information of received submultiframes is automatically inserted at the E-bit position of the outgoing CRC Multiframe without any further interventions of the microprocessor.
- Automatic AIS to system interface
In asynchronous state the synchronizer enforces an AIS to the receive system interface automatically. However, received data can be switched through transparently, if bit FMR2.DAIS is set.
- Automatic clock source switching
In slave mode (LIM0.MAS = 0) the DCO-R synchronizes to the recovered route clock. In case of loss-of-signal (LOS) the DCO-R switches to Master mode automatically. If bit CMR1.DCS is set, automatic switching from RCLK to SYNC is disabled.
- Automatic freeze signaling:
Updating of the received signaling information is controlled by the freeze signaling status. The freeze signaling status is automatically activated if a loss-of-signal or a

Functional Description E1

loss of CAS multiframe alignment or a receive slip occurs. The internal signaling buffer RS(16:1) is frozen. Optionally automatic freeze signaling is disabled by setting bit SIC3.DAF.

4.3.3 Error Counter

The FALC56 offers six error counters where each of them has a length of 16 bit. They record code violations, framing bit errors, CRC4-bit errors and CRC4 error events which are flagged in the different S_a 6-bit combinations or the number of received multiframe in asynchronous state or the change of frame alignment (COFA). Counting of the multiframe in the asynchronous state and the COFA parameter is done in a 6/2 bit counter and is shared with CEC3L/H. Each of the error counters is buffered. Buffer updating is done in two modes:

- One-second accumulation
- On demand by handshake with writing to the DEC register

In the one-second mode an internal/external one-second timer updates these buffers and resets the counter to accumulate the error events in the next one-second period. The error counter cannot overflow. Error events occurring during an error counter reset are not lost.

4.3.4 Errored Second

The FALC56 supports the error performance monitoring by detecting the following alarms or error events in the received data:

framing errors, CRC errors, code violations, loss of frame alignment, loss-of-signal, alarm indication signal, E-bit error, receive and transmit slips.

With a programmable interrupt mask register ESM all these alarms or error events can generate an errored second interrupt (ISR3.ES) if enabled.

4.3.5 One-Second Timer

Additionally, a one-second timer interrupt can be generated internally to indicate that the enabled alarm status bits or the error counters have to be checked. The one-second timer signal is output on port SEC/FSC (GPC1.CSFP1/0). Optionally synchronization to an external second timer is possible which has to be provided on pin SEC/FSC. Selecting the external second timer is done with GCR.SES. Refer also to register GPC1 for input/output selection.

4.3.6 In-Band Loop Generation and Detection

The FALC56 generates and detects a framed or unframed in-band loop-up (activate) and loop-down (deactivate) pattern with bit error rates up to 10^{-2} . Framed or unframed in-band loop code is selected by LCR1.FLLB. Replacing transmit data with the in-band loop codes is done by programming FMR3.XLD/XLU.

Functional Description E1

The FALC56 also offers the ability to generate and detect a flexible in-band loop-up and loop-down pattern (LCR1.LLBP = 1). The loop-up and loop-down pattern is individually programmable from 2 to 8 bits in length (LCR1.LAC1/0 and LCR1.LDC1/0). Programming of loop codes is done in registers LCR2 and LCR3. Status and interrupt status bits inform the user whether loop-up or loop-down code has been detected.

4.3.7 Time Slot 0 Transparent Mode

The transparent modes are useful for loop-backs or for routing data unchanged through the FALC56.

In receive direction, transparency for ternary or dual-/single-rail unipolar data is always achieved if the receiver is in the synchronous state. In asynchronous state data is transparently switched through if bit FMR2.DAIS is set. However, correct time slot assignment cannot be guaranteed due to missing frame alignment between line and system side.

Setting of bit LOOP.RTM disconnects control of the internal elastic store from the receiver. The elastic buffer is now in a “free running” mode without any possibility to update the time slot assignment to a new frame position in case of resynchronization of the receiver. Together with FMR2.DAIS this function can be used to realize undisturbed transparent reception.

Transparency in transmit direction can be achieved by activating the time slot 0 transparent mode (bit XSP.TT0 or TSWM.(7:0)). If XSP.TT0 = 1 all internal information of the FALC56 (framing, CRC, S_a/S_i-bit signaling, remote alarm) is ignored. With register TSWM the S_i-bits, A-bit or the S_a-bits can be enabled selectively to send data transparently from port XDI to the far end. For complete transparency the internal signaling controller, idle code generation and AIS alarm generation, single channel and payload loop-back have to be disabled.

4.4 Transmit Path in E1 Mode

4.4.1 Transmitter (E1)

The serial bit stream is processed by the transmitter which has the following functions:

- Frame/multiframe synthesis of one of the two selectable framing formats
- Insertion of service and data link information
- AIS generation (Alarm indication signal)
- Remote alarm generation
- CRC generation and insertion of CRC bits
- CRC bits inversion in case of a previously received CRC error
- Idle code generation per DS0

The frame/multiframe boundaries of the transmitter can be externally synchronized by using the $\overline{\text{SYPX}}/\text{XMFS}$ pin. Any change of the transmit time slot assignment subsequently produces a change in the framing bit positions on the line side. This feature is required if signaling and service bits are routed through the switching network and are inserted in transmit direction by the system interface.

In loop-timed configuration ($\text{LIM2.ELT} = 1$) disconnecting the control of the transmit system highway from the transmitter is done by setting XSW.XTM . The transmitter is now in a free running mode without any possibility to update the multiframe position in case of changing the transmit time slot assignment. The framing bits are generated independently of the transmit system interface. For proper operation the transmit elastic buffer size should be programmed to 2 frames.

The contents of selectable time slots can be overwritten by the pattern defined by register IDLE . The selection of "idle channels" is done by programming the four-byte registers $\text{ICB1} \dots \text{ICB4}$.

4.4.2 Transmit Line Interface (E1)

The analog transmitter transforms the unipolar bit stream to ternary (alternate bipolar) return to zero signals of the appropriate programmable shape. The unipolar data is provided by the digital transmitter.

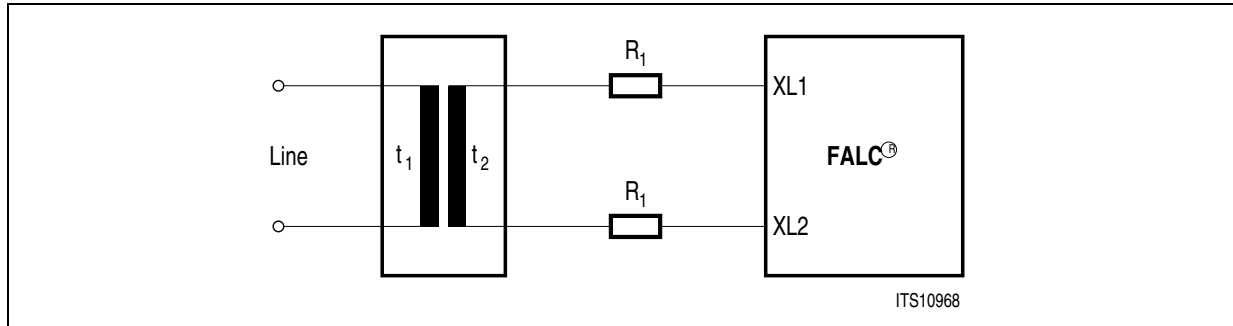

Figure 23 Transmitter Configuration (E1)

Table 21 Recommended Transmitter Configuration Values (E1)

Parameter	Characteristic Impedance [Ω]	
	120	75
$R_1 (\pm 1\%) [\Omega]$	$7.5^{1)}$	$7.5^{1)}$
$t_2 : t_1$	1 : 2.4	1 : 2.4

¹⁾ This value refers to an ideal transformer without any parasitics. Any transformer resistance or other parasitic resistances have to be taken into account when calculating the final value of the output serial resistors.

Similar to the receive line interface three different data types are supported:

- Ternary Signal
Single-rail data is converted into a ternary signal which is output on pins XL1 and XL2. The HDB3 and AMI line code is employed. Selected by FMR0.XC1/0 and LIM1.DRS = 0.
- Dual-rail data PCM(+), PCM(–) at multifunction ports XDOP/XDON with 50% or 100% duty cycle and with programmable polarity. Line coding is done in the same way as in ternary interface mode. Selected by FMR0.XC1/0 and LIM1.DRS = 1.
- Unipolar data on port XOID is transmitted either in NRZ (Non Return to Zero) with 100% duty cycle or in CMI (Code Mark Inversion or known as 1T2B) Code with or without (FMR3.CMI) preprocessed HDB3 coding to a fiber-optical interface. Clocking off data is done with the rising edge of the transmit clock XCLK (2048 kHz) and with a programmable polarity. Selection is done by FMR0.XC1 = 0 and LIM1.DRS = 1.

4.4.3 Transmit Jitter Attenuator (E1)

The transmit jitter attenuator DCO-X circuitry generates a "jitter-free" transmit clock and meets the following requirements: ITU-T I.431, G. 703, G. 736 to 739, G.823 and ETSI TBR12/13. The DCO-X circuitry works internally with the same high frequency clock as the receive jitter attenuator. It synchronizes either to the working clock of the transmit backplane interface or the clock provided on pin TCLK or the receive clock RCLK (remote loop/loop-timed). The DCO-X attenuates the incoming clock jitter starting at 2 Hz with 20 dB per decade fall-off. With the jitter attenuated clock, which is directly depending on the phase difference of the incoming clock and the jitter attenuated clock, data is read from the transmit elastic buffer (2 frames) or from the JATT buffer (2 frames, remote loop). Wander with a jitter frequency below 2 Hz is passed transparently.

The DCO-X accepts gapped clocks which are used in ATM or SDH/SONET applications. The jitter attenuated clock is output on pin XCLK or optionally on pin CLK2.

In case of missing clock on pin SCLKX the DCO-X centers automatically, if selected by bit `CMR2.DCOXC = 1`.

The transmit jitter attenuator can be disabled. In that case data is read from the transmit elastic buffer with the clock sourced on pin TCLK (2.048 or 8.192 MHz). Synchronization between SCLKX and TCLK has to be done externally.

In the loop-timed clock configuration (LIM2.ELT) the DCO-X circuitry generates a transmit clock which is frequency synchronized on RCLK. In this configuration the transmit elastic buffer has to be enabled.

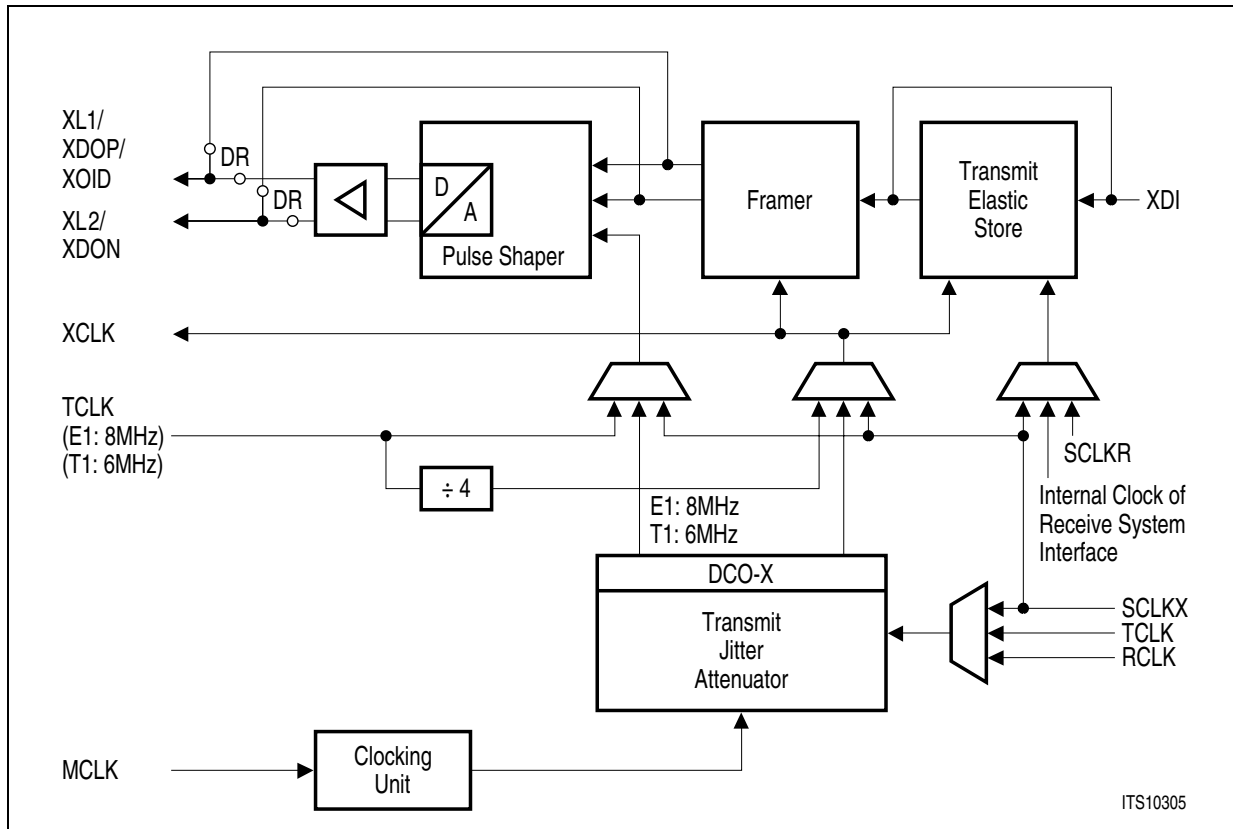

Figure 24 Transmit Clock System (E1)

Note: DR = Dual-Rail interface
DCO-X Digital Controlled Oscillator transmit

4.4.4 Transmit Elastic Buffer (E1)

The received bit stream from pin XDI is optionally stored in the transmit elastic buffer. The memory is organized as the receive elastic buffer. The functions are also equal to the receive side. Programming of the transmit buffer size is done by SIC1.XBS1/0:

- XBS1/0 = 00: Bypass of the transmit elastic buffer
- XBS1/0 = 01: one frame buffer or 256 bits
Maximum of wander amplitude (peak-to-peak): 100 UI (1 UI = 488 ns)
average delay after performing a slip: 128 bits
- XBS1/0 = 10: two frame buffer or 512 bits
Maximum of wander amplitude: 190 UI
average delay after performing a slip: 1 frame or 256 bits
- XBS1/0 = 11: short buffer or 92 bits:
Maximum of wander amplitude: 18 us
average delay after performing a slip: 46 bits

The functions of the transmit buffer are:

Functional Description E1

- Clock adaption between system clock (SCLKX) and internally generated transmit route clock (XCLK).
- Compensation of input wander and jitter.
- Frame alignment between system frame and transmit route frame
- Reporting and controlling of slips

Writing of received data from XDI is controlled by SCLKX/R and $\overline{\text{SYPX}}/\text{XMFS}$ in combination with the programmed offset values for the transmit time slot/clock slot counters. Reading of stored data is controlled by the clock generated by DCO-X circuitry or the externally generated TCLK and the transmit framer. With the de-jittered clock data is read from the transmit elastic buffer and are forwarded to the transmitter. Reporting and controlling of slips is done according to the receive direction. Positive/negative slips are reported in interrupt status bits ISR4.XSP and ISR4.XSN. If the transmit buffer is bypassed data is directly transferred to the transmitter.

The following table gives an overview of the transmit buffer operating modes.

Table 22 Transmit Buffer Operating Modes (E1)

SIC1.XBS(1:0)	Buffer Size	TS Offset programming	Slip performance
00	bypass	enabled	no
11	short buffer	enabled	yes
01	1 frame	enabled	yes
10	2 frames	enabled	yes

4.4.5 Programmable Pulse Shaper (E1)

The analog transmitter includes a programmable pulse shaper to satisfy the requirements of ITU-T I.431. The amplitude and shape of the transmit pulses are completely programmable by registers XPM(2:0).

The transmitter requires an external step up transformer to drive the line.

4.4.6 Transmit Line Monitor (E1)

The transmit line monitor compares the transmit line current on XL1 and XL2 with an on-chip transmit line current limiter. The monitor detects faults on the primary side of the transformer indicated by a highly increased transmit line current (more than 120 mA for at least 3 consecutive pulses sourced by V_{DDX} ¹⁾) and protects the device from damage by setting the transmit line driver XL1/2 into high-impedance state automatically (if enabled by XPM2.DAXLT = 0). The current limiter checks the actual current value of

¹⁾ shorts between XL1 or XL2 and V_{DDX} are not detected

Functional Description E1

XL1/2 and if the transmit line current drops below the detection limit the high-impedance state is cleared.

Two conditions are detected by the monitor: transmit line de-jitteredity (more than 31 consecutive zeros) indicated by FRS1.XLO and transmit line high current indicated by FRS1.XLS. In both cases a transmit line monitor status change interrupt is provided.

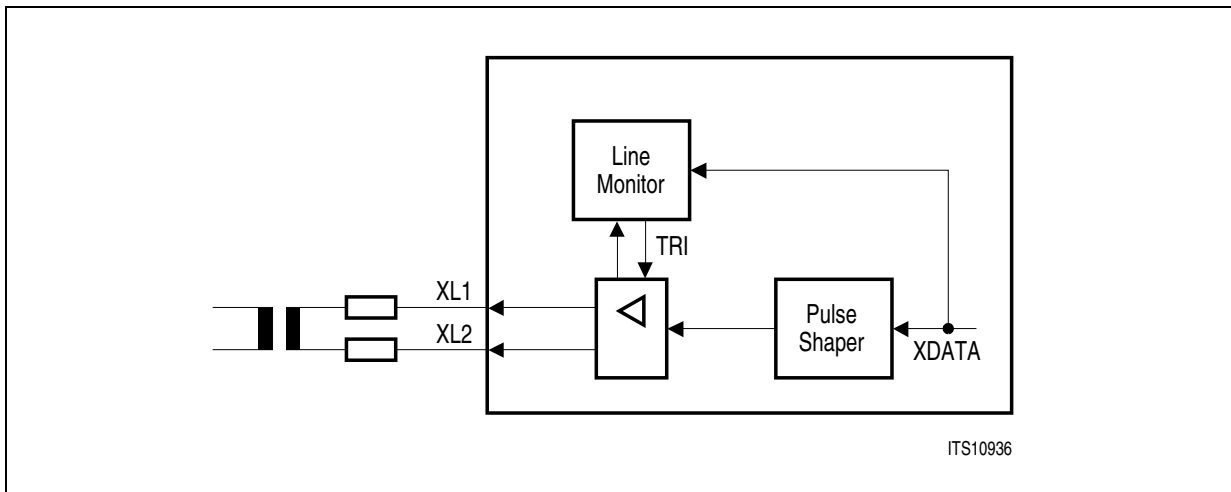

Figure 25 Transmit Line Monitor Configuration (E1)

4.4.7 Transmit Signaling Controller (E1)

Similar to the receive signaling controller the same signaling methods and the same time slot assignment is provided. The FALC56 performs the following signaling and data link methods.

4.4.7.1 HDLC or LAPD access

The transmit signaling controller of the FALC56 performs the flag generation, CRC generation, zero-bit stuffing and programmable idle code generation. Buffering of transmit data is done in the 64 byte deep XFIFO. The signaling information is internally multiplexed with the data applied to port XDI or XSIG.

In signaling controller transparent mode, fully transparent data transmission without HDLC framing is performed. Optionally the FALC56 supports the continuous transmission of the XFIFO contents.

The FALC56 offers the flexibility to insert data during certain time slots. Any combinations of time slots can be programmed separately for the receive and transmit direction if using HDLC channel 1. HDLC channel 2 and 3 support one programmable time slot common for receive and transmit direction each.

4.4.7.2 Support of Signaling System #7

The HDLC controller of channel 1 supports the signaling system #7 (SS7) which is described in ITU-Q.703. The following description assumes, that the reader is familiar with the SS7 protocol definition.

SS7 support must be activated by setting the MODE register. Data stored in the transmit FIFO (XFIFO) is sent automatically. The SS7 protocol is supported by the following hardware features in transmit direction:

- transmission of flags at the beginning of each Signaling Unit
- bit stuffing (zero insertion)
- calculation of the CRC16 checksum:

The transmitter adds the checksum to each Signaling Unit.

Each Signaling Unit written to the transmit FIFO (XFIFO, 2×32 bytes) is sent once or repeatedly including flags, CRC checksum and stuffed bits. After e.g. an MSU has been transmitted completely, the FALC56 optionally starts sending of FISUs containing the forward sequence number (FSN) and the backward sequence number (BSN) of the previously transmitted Signaling Unit. Setting bit CCR5.AFX causes Fill In Signaling Units (FISUs) to be sent continuously, if no HDLC or Signaling Unit (SU) is to be transmitted from XFIFO. During update of XFIFO, automatic transmission is interrupted and resumed after update is completed. The internally generated FISUs contain FSN and BSN of the last transmitted Signaling Unit written to XFIFO.

Using $CMDR.XREP = 1$, the contents of XFIFO can be sent continuously. Clearing of $CMDR.XRES/SRES$ stops the automatic repetition of transmission. This function is also available for HDLC frames, so no flag generation, CRC byte generation and bit stuffing is necessary.

Example: After an MSU has been sent repetitively and XREP has been cleared, FISUs are sent automatically.

4.4.7.3 S_a -Bit Access (E1)

The FALC56 supports the S_a -bit signaling of time slot 0 of every other frame as follows:

- the access through register XSW
- the access through registers XSA(8:4), capable of storing the information for a complete multiframe
- the access through the 64 byte deep XFIFO of the signaling controller (HDLC channel 1 only)

This S_a -bit access gives the opportunity to transparent a bit stream as well as HDLC frames where the signaling controller automatically processes the HDLC protocol. Any combination of S_a -bits which shall be inserted in the outgoing data stream can be selected by $XC0.SA(8:4)$.

4.4.7.4 Channel Associated Signaling CAS (E1, serial mode)

In external signaling mode (serial mode) the signaling data received on port XSIG is sampled with the working clock of the transmit system interface (SCLKX) in combination with the transmit synchronization pulse ($\overline{\text{SYPX}}$). Data on XSIG is latched in the bit positions 5 to 8 per time slot, bits 1 to 4 are ignored. Time slots 0 and 16 are sampled completely (bit 1 to 8). The received CAS multiframe is inserted frame aligned into the data stream on XDI and must be valid during the last frame of a multiframe if CRC4/multiframe mode is selected. The CAS multiframe is aligned to the CRC4-multiframe; other frames are ignored. Data sourced by the internal signaling controller (μP access mode) overwrites the external signaling data.

If the FALC56 is configured for no signaling, the system interface data stream passes the FALC56 undisturbedly.

Note: CAS data on XSIG is read in the last frame of a multiframe only and ignored in all other frames.

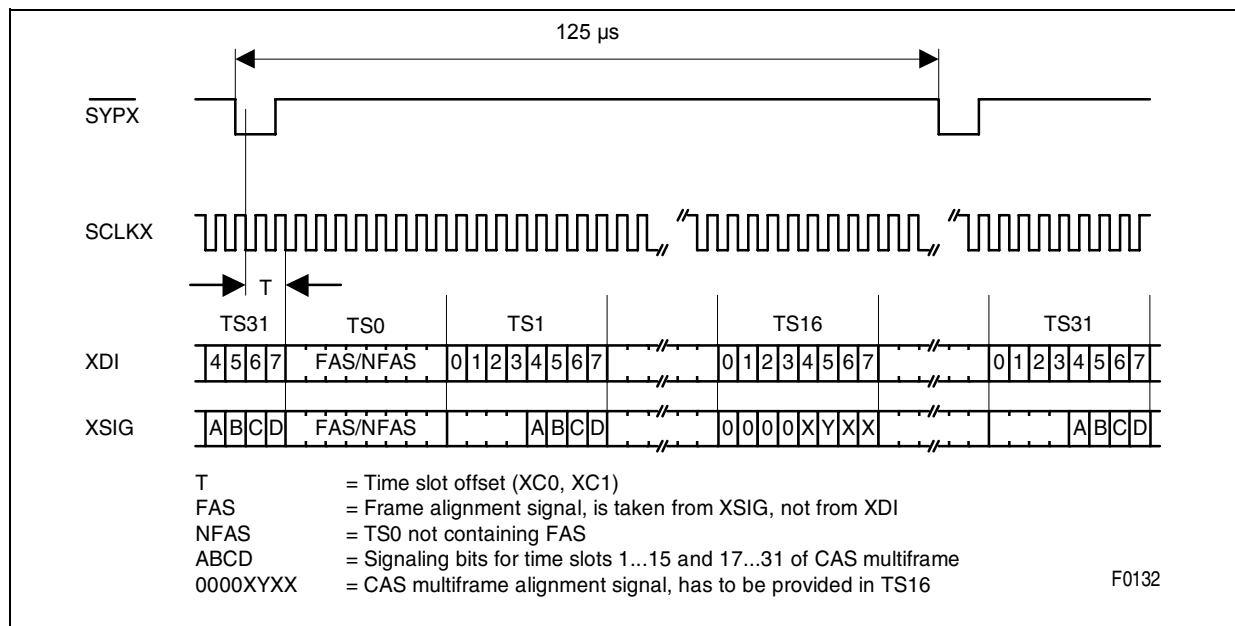

Figure 26 2.048 MHz Transmit Signaling Highway (E1)

4.4.7.5 Channel Associated Signaling CAS (E1, μP access mode)

Transmit data stored in registers XS(16:1) is transmitted on a multiframe boundary in time slot 16. The signaling controller inserts the bit stream either on the transmit line side or, if external signaling is enabled, on the transmit system side using pin function XSIG. Data sourced by the internal signaling controller overwrites the external signaling data.

If the FALC56 is configured for no signaling, the system interface data stream passes the FALC56 undisturbedly.

4.5 System Interface in E1 Mode

The FALC56 offers a flexible feature for system designers where for transmit and receive direction different system clocks and system pulses are necessary. The interface to the receive system highway is realized by two data buses, one for the data RDO and one for the signaling data RSIG. The receive highway is clocked on pin SCLKR, while the interface to the transmit system highway is independently clocked on pin SCLKX. The frequency of these working clocks and the data rate of 2.048/4.096/8.192/16.384 Mbit/s for the receive and transmit system interface is programmable by SIC1.SSC1/0, and SIC1.SSD1, FMR1.SSD0. Selectable system clock and data rates and their valid combinations are shown in the table below

Table 23 System Clocking and Data Rates (E1)

System Data Rate	Clock Rate 2.048 MHz	Clock Rate 4.096 MHz	Clock Rate 8.192 MHz	Clock Rate 16.384 MHz
2.048 Mbit/s	x	x	x	x
4.096 Mbit/s	--	x	x	x
8.192 Mbit/s	--	--	x	x
16.384 Mbit/s	--	--	--	x

x = valid, -- = invalid

Generally the data or marker on the system interface are clocked off or latched on the rising or falling edge (SIC3.RESR/X) of the SCLKR/X clock. Some clocking rates allow transmission of time slots in different channel phases. Each channel phase which shall be active on ports RDO, XDI, RP(A:D) and XP(A:D) is programmable by SIC2.SICS(2:0), the remaining channel phases are cleared or ignored.

The signals on pin $\overline{\text{SYPR}}$ together with the assigned time slot offset in register RC0 and RC1 define the beginning of a frame on the receive system highway. The signal on pin $\overline{\text{SYPX}}$ or XMFS together with the assigned time slot offset in register XC0 and XC1 define the beginning of a frame on the transmit system highway.

Adjusting the frame begin (time slot 0, bit 0) relative to $\overline{\text{SYPR/X}}$ or XMFS is possible in the range of 0 to 125 μs . The minimum shift of varying the time slot 0 begin can be programmed between 1 bit and 1/8 bit depending of the system clocking and data rate, e.g. with a clocking/data rate of 2.048 MHz shifting is done bit by bit, while running the FALC56 with 16.384 MHz and 2.048 Mbit/s data rate it is done by 1/8 bit.

A receive frame marker RFM can be activated during any bit position of the entire frame. Programming is done with registers RC1/0. The pin function RFM is selected by PC(4:1).RPC(2:0) = 001. The RFM selection disables the internal time slot assigner, no offset programming is performed. The receive frame marker is active high for one

Functional Description E1

2.048 MHz cycle and is clocked off with the rising or falling edge of the clock which is in/output on port SCLKR (see SIC3.RESR/X).

Compared to the receive path the inverse functions are performed for the transmit direction.

The interface to the transmit system highway is realized by two data buses, one for the data XDI and one for the signaling data XSIG. The time slot assignment is equivalent to the receive direction.

Latching of data is controlled by the system clock (SCLKX) and the synchronization pulse ($\overline{\text{SYPX}}/\text{XMFS}$) in combination with the programmed offset values for the transmit time slot/clock slot counters XC1/0. The frequency of the working clock of 2.048/4.096/8.192/16.384 MHz for the transmit system interface is programmable by SIC1.SSC1/0. Refer also to **Table 23**.

The received bit stream on ports XDI and XSIG can be multiplexed internally on a time slot basis, if enabled by SIC3.TTRF = 1. The data received on port XSIG can be sampled if the transmit signaling marker XSIGM is active high. Data on port XDI is sampled if XSIGM is low for the corresponding time slot. Programming the XSIGM marker is done with registers TTR(4:1).

Functional Description E1

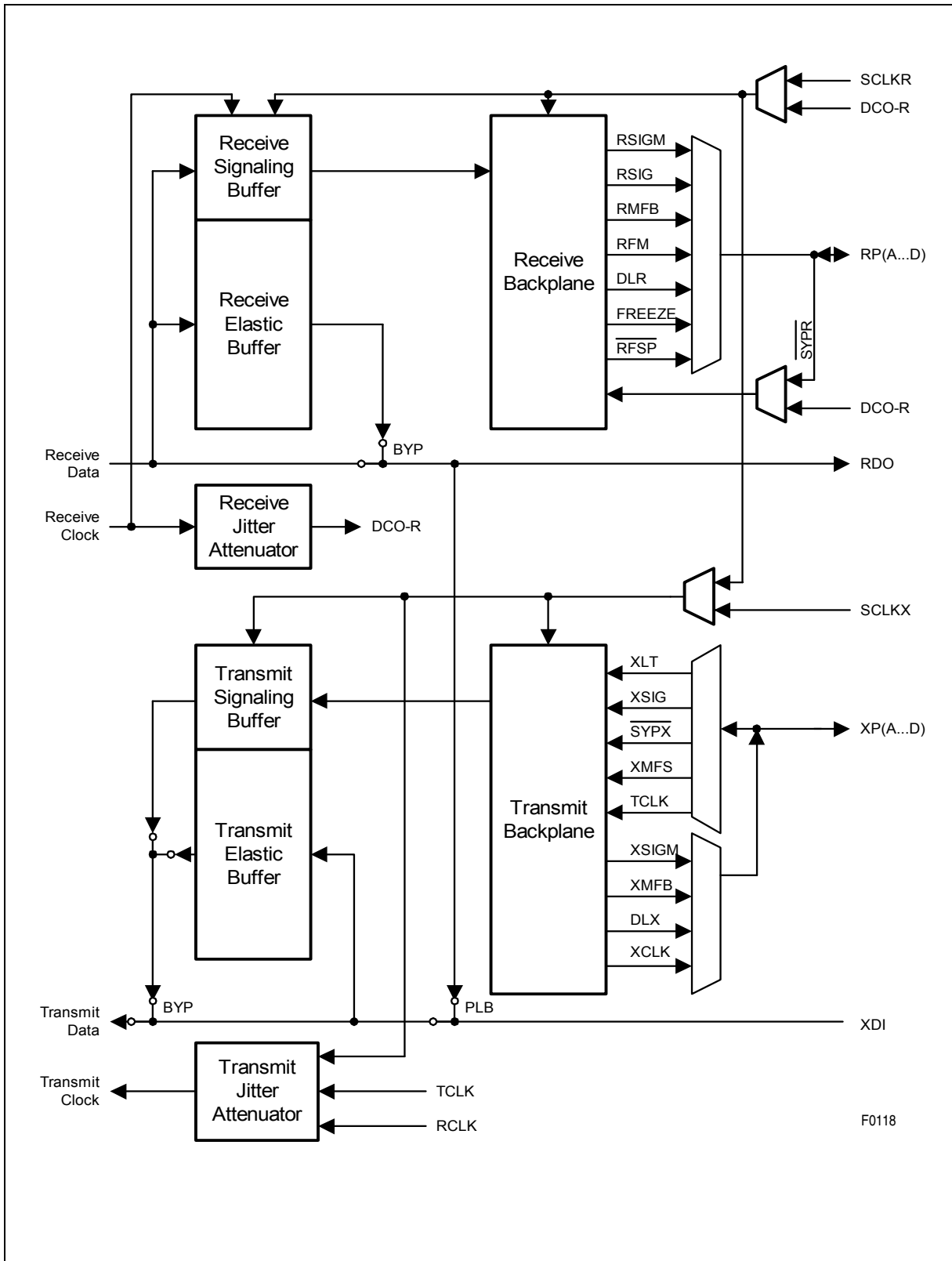

Figure 27 System Interface (E1)

4.5.1 Receive System Interface (E1)

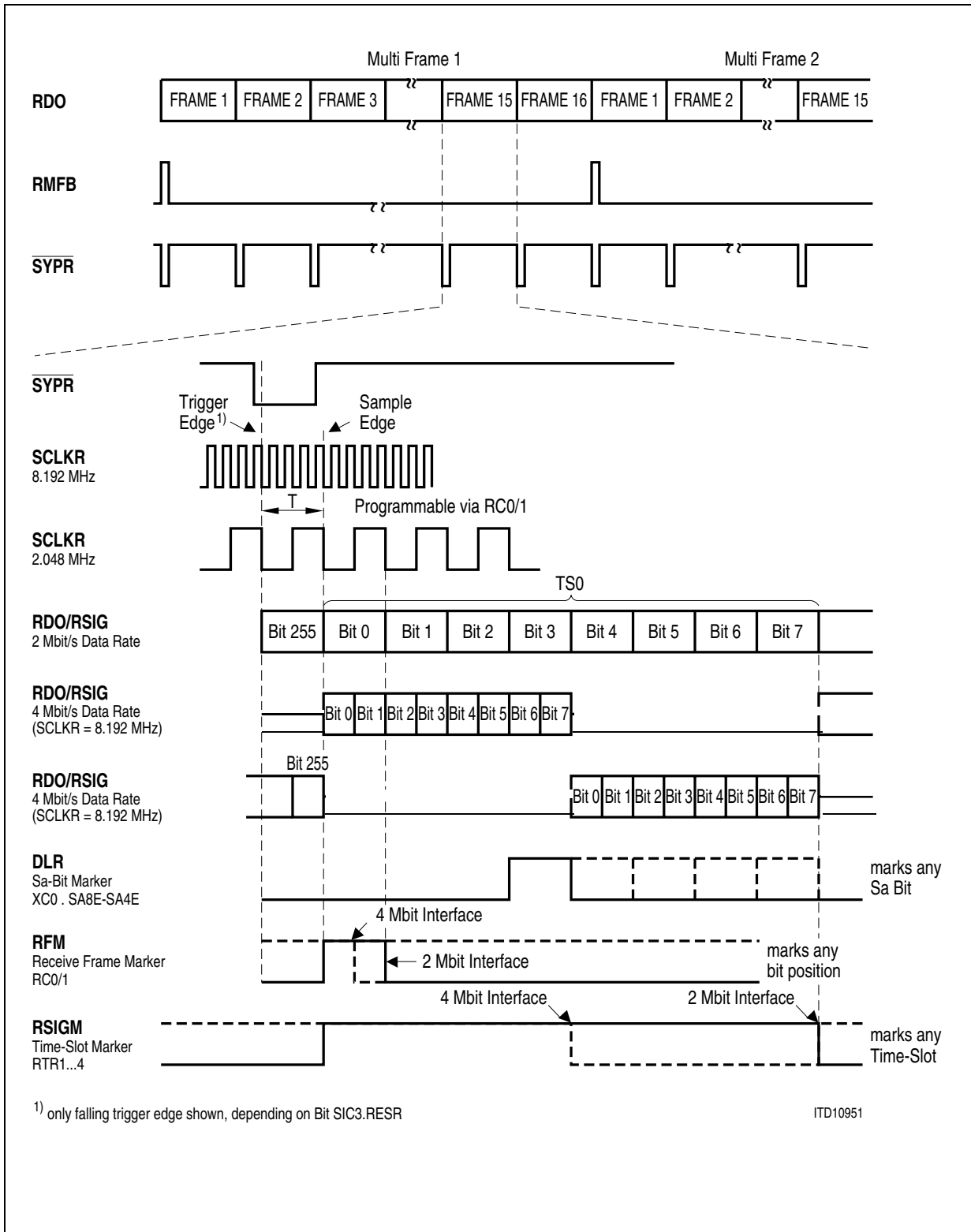

Figure 28 Receive System Interface Clocking (E1)

4.5.1.1 Receive Offset Programming

Depending on the selection of the synchronization signals ($\overline{\text{SYPR}}$ or RFM), different calculation formulas are used to define the position of the synchronization pulses. These formulas are given below, see [Figure 29](#) to [Figure 32](#) for explanation. The pulse length of $\overline{\text{SYPR}}$ and RFM is always the basic E1 bit width (488 ns), independent of the selected system highway clock and data frequency.

$\overline{\text{SYPR}}$ Offset Calculation

- T: Time between beginning of $\overline{\text{SYPR}}$ pulse and beginning of next frame (time slot 0, bit 0), measured in number of SCLKR clock intervals
maximum delay: $T_{\text{max}} = (256 \times \text{SC}/\text{SD}) - 1$
- SD: Basic data rate; 2.048 Mbit/s
- SC: System clock rate; 2.048, 4.096, 8.192, or 16.384 MHz
- X: Programming value to be written to registers RC0 and RC1 (see [page 239](#)).

$$0 \leq T \leq 4: \quad X = 4 - T$$

$$5 \leq T \leq T_{\text{max}}: \quad X = 2052 - T$$

RFM Offset Calculation

- MP: Marker position of RFM, counting in SCLKR clock cycles
(0 = bit 1, time slot 0, channel phase 0)
- SC = 2.048 MHz: $0 \leq \text{MP} \leq 255$
- SC = 4.096 MHz: $0 \leq \text{MP} \leq 511$
- SC = 8.192 MHz: $0 \leq \text{MP} \leq 1023$
- SC = 16.384 MHz: $0 \leq \text{MP} \leq 2047$
- SD: Basic data rate; 2.048 Mbit/s
- SC: System clock rate; 2.048, 4.096, 8.192, or 16.384 MHz
- X: Programming value to be written to registers RC0 and RC1 (see [page 239](#)).

$$0 \leq \text{MP} \leq 2045: \quad X = \text{MP} + 2$$

$$2046 \leq \text{MP} \leq 2047: \quad X = \text{MP} - 2046$$

Functional Description E1

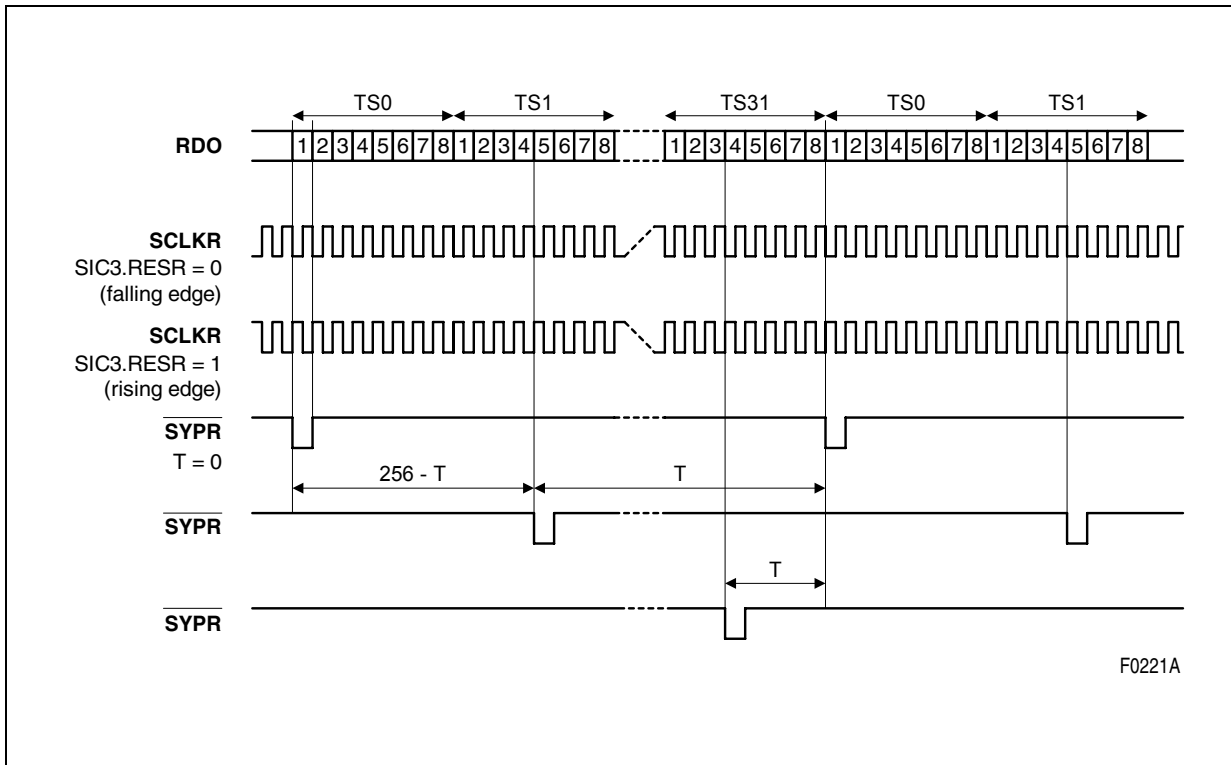

Figure 29 SYPR Offset Programming (2.048 Mbit/s, 2.048 MHz)

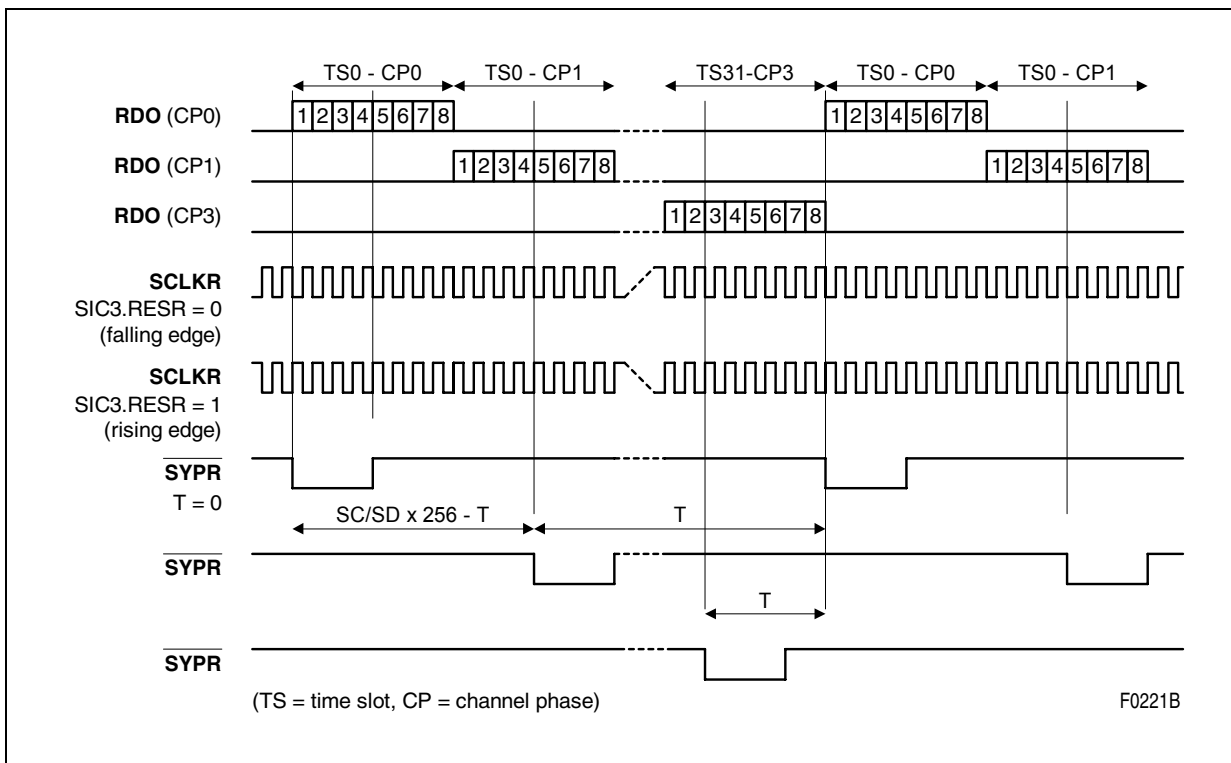

Figure 30 SYPR Offset Programming (8.192 Mbit/s, 8.192 MHz)

Functional Description E1

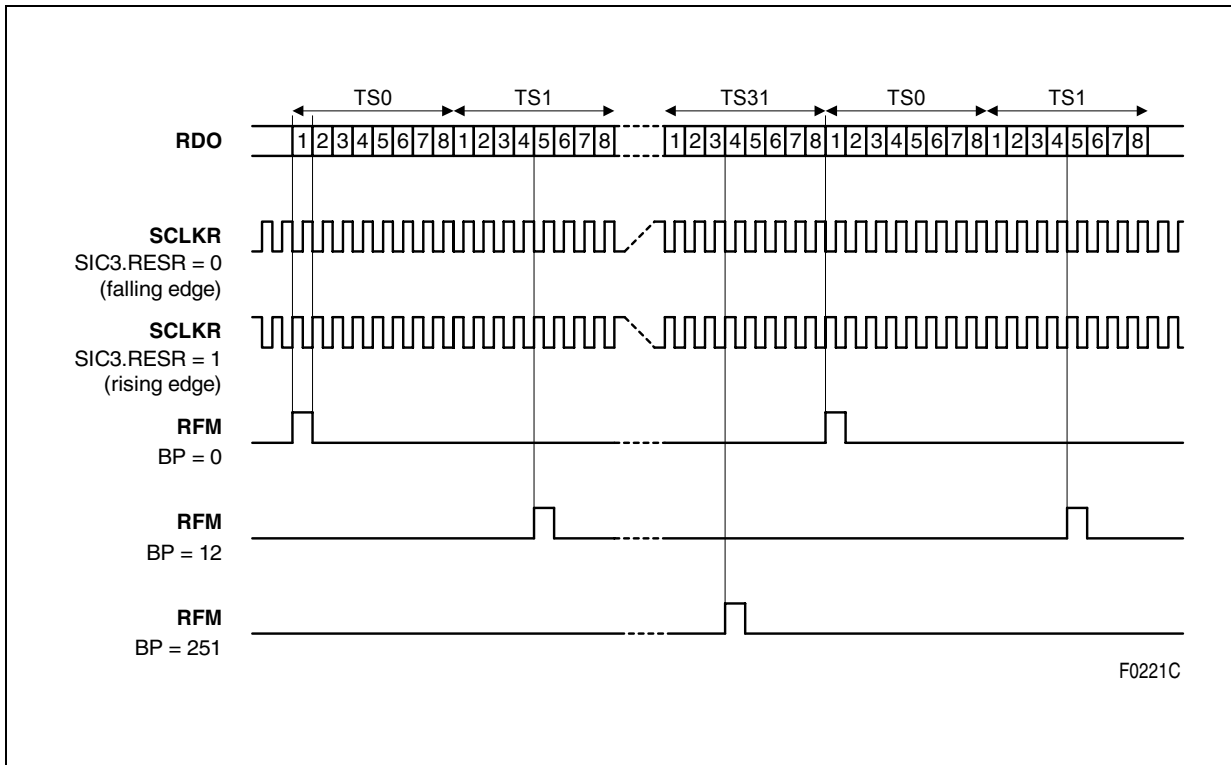

Figure 31 RFM Offset Programming (2.048 Mbit/s, 2.048 MHz)

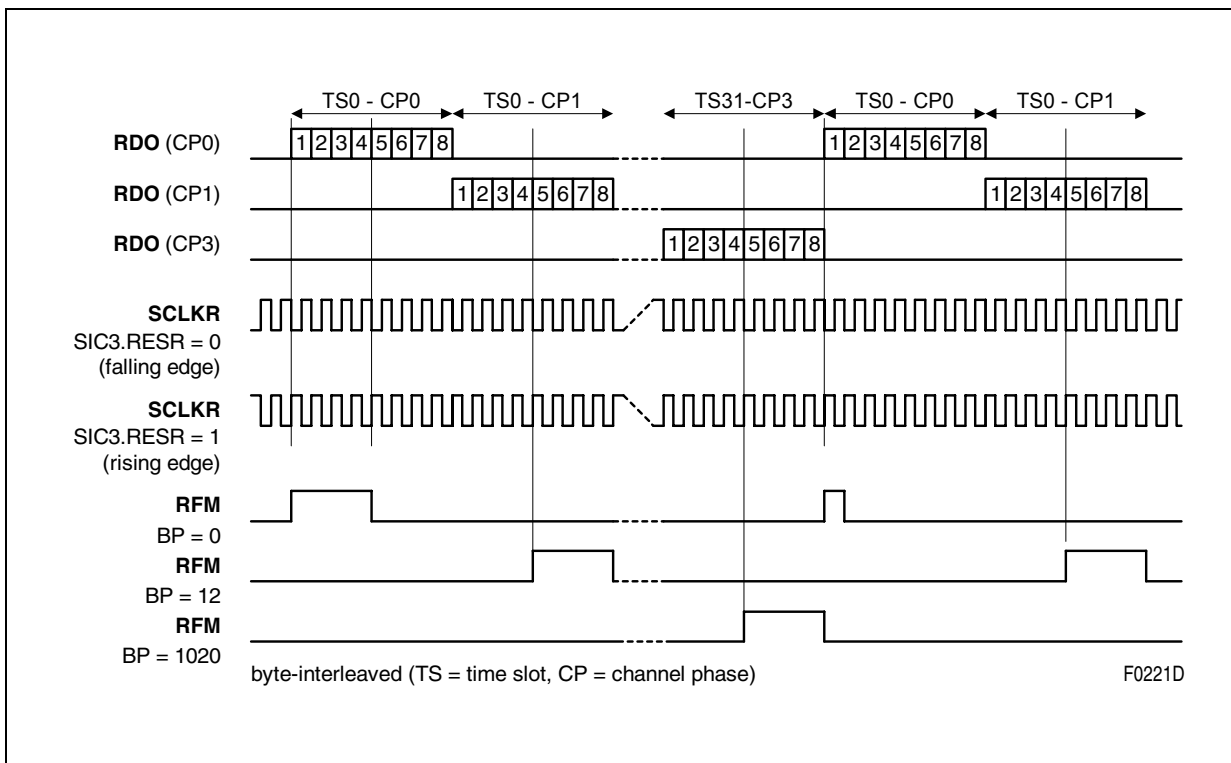

Figure 32 RFM Offset Programming (8.192 Mbit/s, 8.192 MHz)

4.5.2 Transmit System Interface (E1)

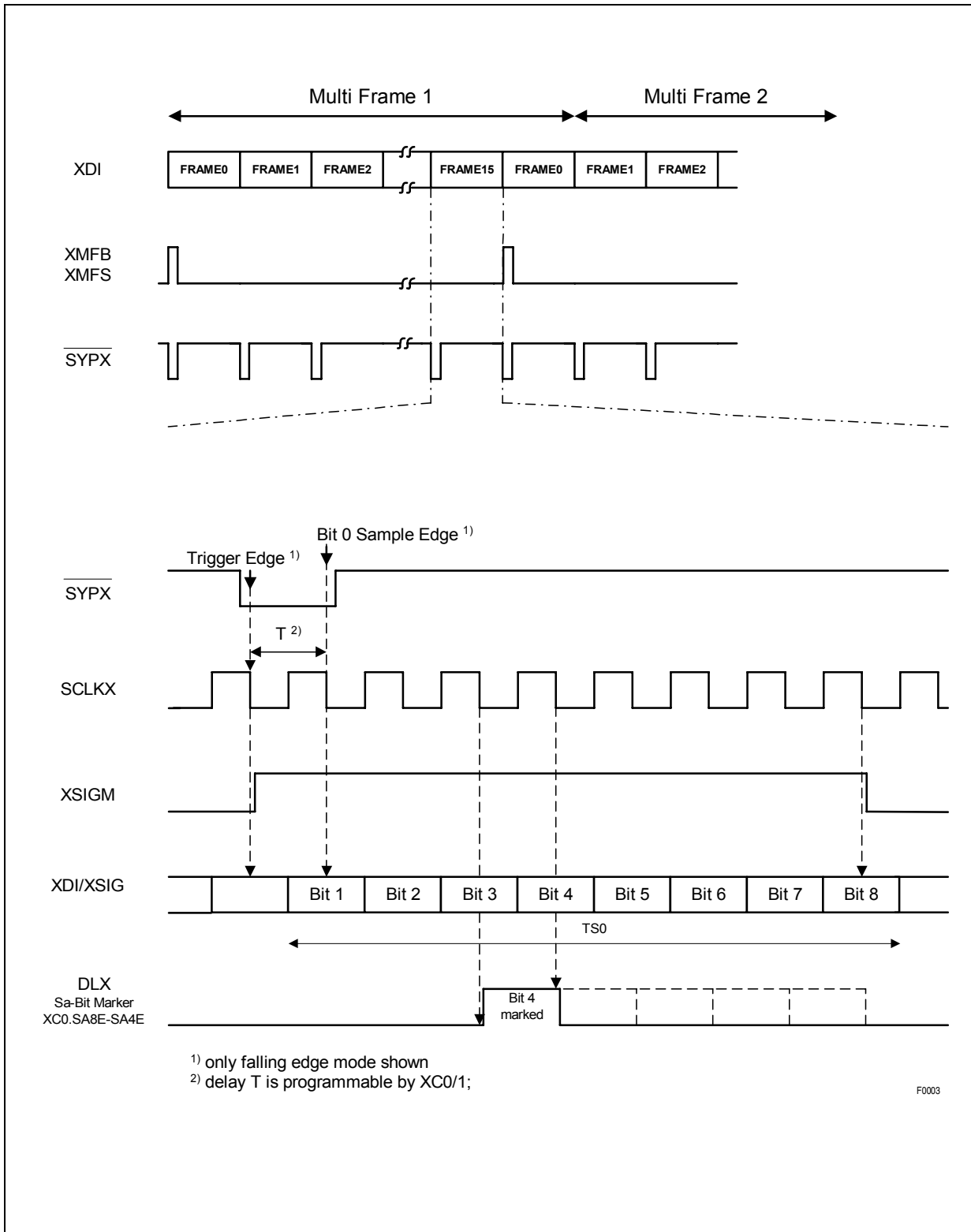

Figure 33 Transmit System Interface Clocking: 2.048 MHz (E1)

Functional Description E1

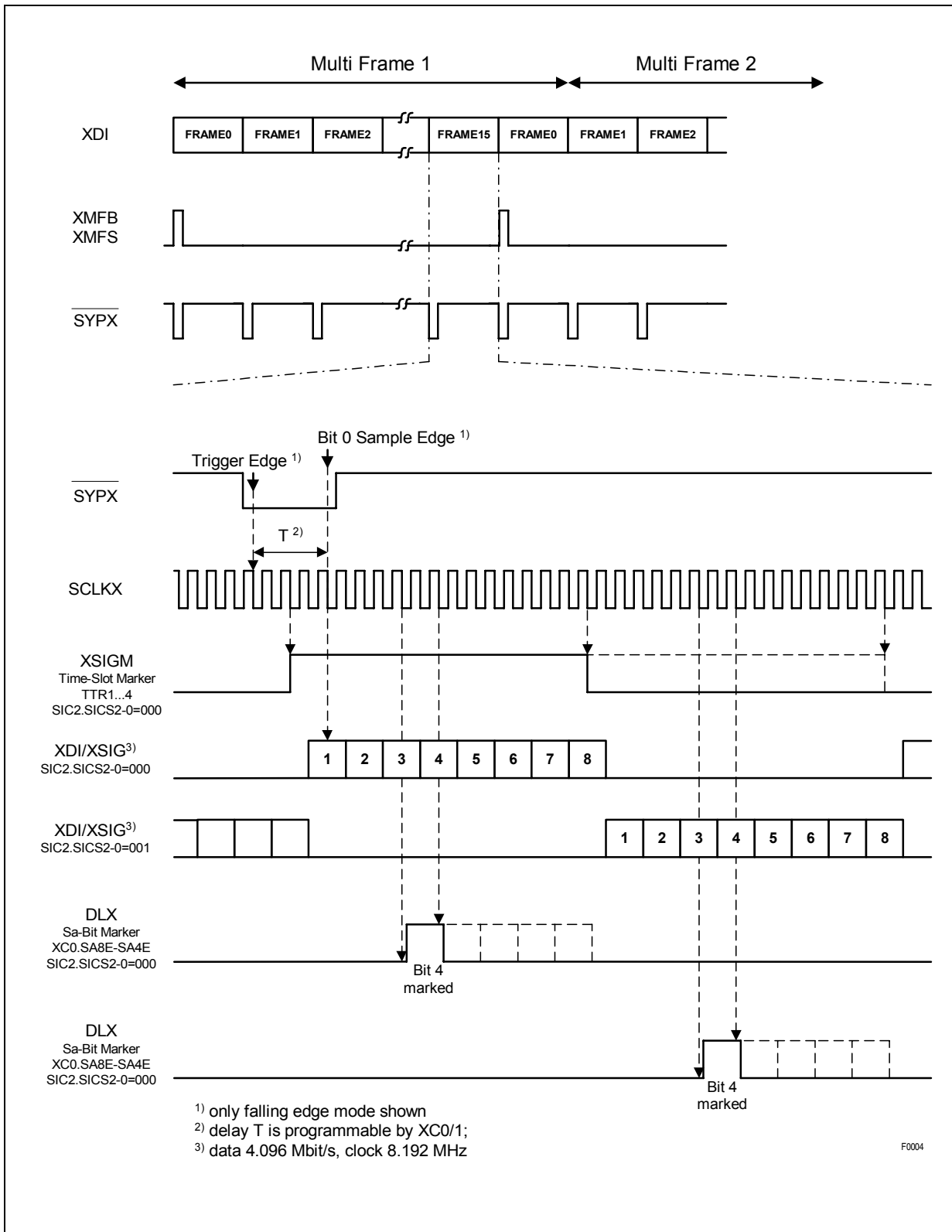

Figure 34 Transmit System Interface Clocking: 8.192 MHz/4.096 Mbit/s (E1)

4.5.2.1 Transmit Offset Programming

The pulse length of $\overline{\text{SYPX}}$ is always the basic E1 bit width (488 ns), independent of the selected system highway clock and data frequency.

$\overline{\text{SYPX}}$ Offset Calculation

- T: Time between beginning of $\overline{\text{SYPX}}$ pulse and beginning of next frame (time slot 0, bit 0), measured in number of SCLKX clock intervals
maximum delay: $T_{\max} = (256 \times \text{SC}/\text{SD}) - 1$
- SD: Basic data rate; 2.048 Mbit/s
- SC: System clock rate; 2.048, 4.096, 8.192, or 16.384 MHz
- X: Programming value to be written to registers XC0 and XC1 (see [page 237](#)).

$$0 \leq T \leq 4: \quad X = 4 - T$$

$$5 \leq T \leq T_{\max}: \quad X = 256 \times \text{SC}/\text{SD} - T + 4$$

Functional Description E1

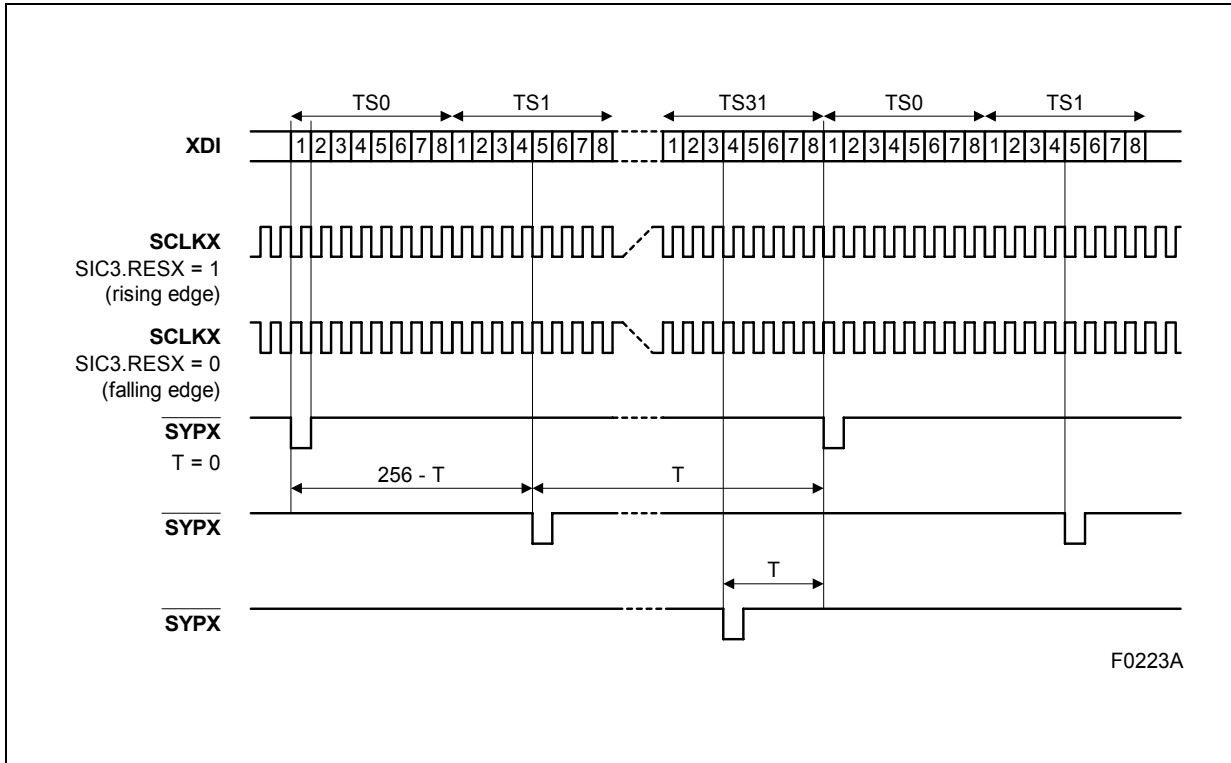

Figure 35 **SYPX** Offset Programming (2.048 Mbit/s, 2.048 MHz)

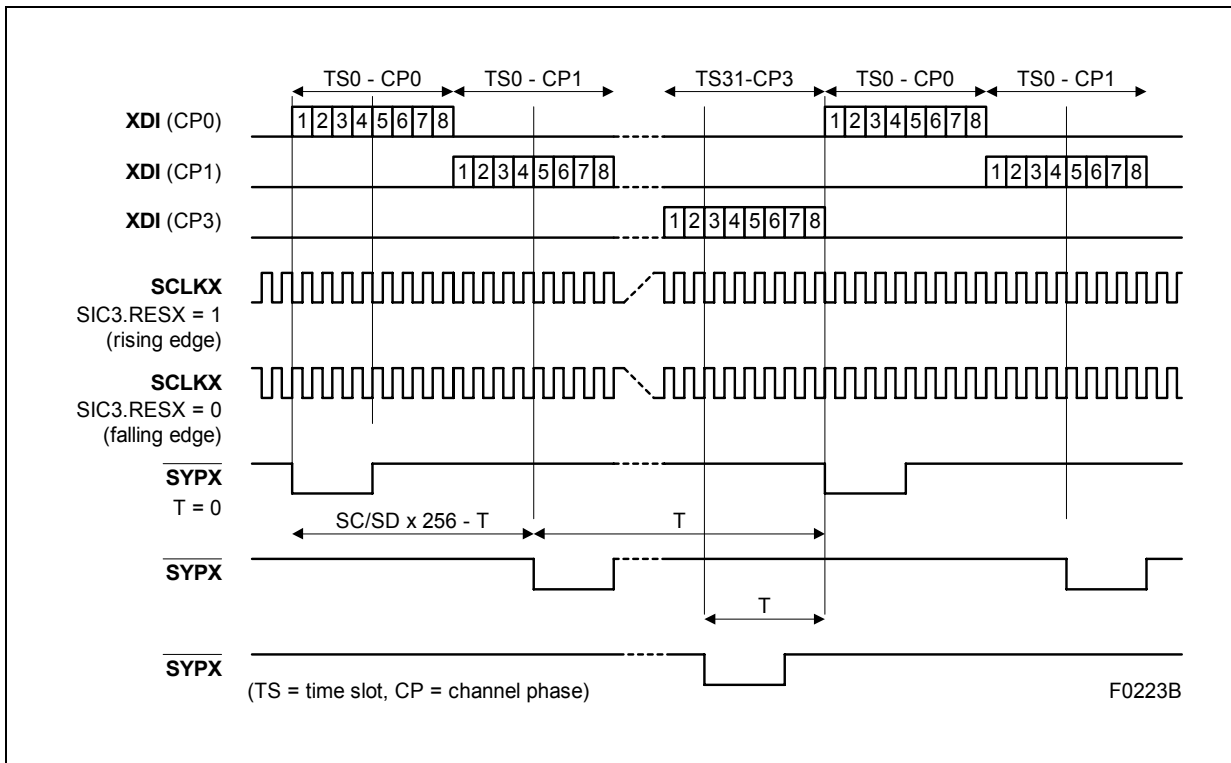

Figure 36 **SYPX** Offset Programming (8.192 Mbit/s, 8.192 MHz)

4.5.3 Time Slot Assigner (E1)

HDLC channel 1 offers the flexibility to connect data during certain time slots, as defined by registers RTR(4:1) and TTR(4:1), to the RFIFO and XFIFO, respectively. Any combinations of time slots can be programmed for the receive and transmit directions. If CCR1.EITS = 1 the selected time slots (RTR(4:1)) are stored in the RFIFO of the signaling controller and the XFIFO contents is inserted into the transmit path as controlled by registers TTR(4:1).

For HDLC channels 2 and 3, one out of 31 time slots can be selected for each channel, but in common for transmit and receive direction.

Within selected time slots single bit positions can be masked to be used/not used for HDLC transmission for all HDLC channels. Additionally, the use of even, odd or both frames can be selected for each HDLC channel individually.

Table 24 Time Slot Assigner HDLC Channel 1 (E1)

Receive Time Slot Register	Transmit Time Slot Register	Time Slots	Receive Time Slot Register	Transmit Time Slot Register	Time Slots
RTR 1.7	TTR 1.7	0	RTR 3.7	TTR 3.7	16
RTR 1.6	TTR 1.6	1	RTR 3.6	TTR 3.6	17
RTR 1.5	TTR 1.5	2	RTR 3.5	TTR 3.5	18
RTR 1.4	TTR 1.4	3	RTR 3.4	TTR 3.4	19
RTR 1.3	TTR 1.3	4	RTR 3.3	TTR 3.3	20
RTR 1.2	TTR 1.2	5	RTR 3.2	TTR 3.2	21
RTR 1.1	TTR 1.1	6	RTR 3.1	TTR 3.1	22
RTR 1.0	TTR 1.0	7	RTR 3.0	TTR 3.0	23
RTR 2.7	TTR 2.7	8	RTR 4.7	TTR 4.7	24
RTR 2.6	TTR 2.6	9	RTR 4.6	TTR 4.6	25
RTR 2.5	TTR 2.5	10	RTR 4.5	TTR 4.5	26
RTR 2.4	TTR 2.4	11	RTR 4.4	TTR 4.4	27
RTR 2.3	TTR 2.3	12	RTR 4.3	TTR 4.3	28
RTR 2.2	TTR 2.2	13	RTR 4.2	TTR 4.2	29
RTR 2.1	TTR 2.1	14	RTR 4.1	TTR 4.1	30
RTR 2.0	TTR 2.0	15	RTR 4.0	TTR 4.0	31

4.6 Test Functions (E1)

4.6.1 Pseudo-Random Binary Sequence Generation and Monitor

The FALC56 has the ability to generate and monitor $2^{15}-1$ and $2^{20}-1$ pseudo-random binary sequences (PRBS). The generated PRBS pattern is transmitted to the remote end on pins XL1/2 or XDOP/N and can be inverted optionally. Generating and monitoring of PRBS pattern is done according to ITU-T O.151.

The PRBS monitor senses the PRBS pattern in the incoming data stream. Synchronization is done on the inverted and non-inverted PRBS pattern. The current synchronization status is reported in status and interrupt status registers. Enabled by bit LCR1.EPRM each PRBS bit error increments an error counter (CEC2). Synchronization is reached within 400 ms with a probability of 99.9% at a bit error rate of up to 10^{-1} .

The PRBS generator and monitor can be used to handle either a framed (TPC0.FRA = 1) or an unframed (TPC0.FRA = 0) data stream.

4.6.2 Remote Loop

In the remote loop-back mode the clock and data recovered from the line inputs RL1/2 or RDIP/RDIN are routed back to the line outputs XL1/2 or XDOP/XDON through the analog or digital transmitter. As in normal mode they are also processed by the synchronizer and then sent to the system interface. The remote loop-back mode is selected by setting the corresponding control bits LIM1.RL and LIM1.JATT. Received data can be looped with or without the transmit jitter attenuator (FIFO).

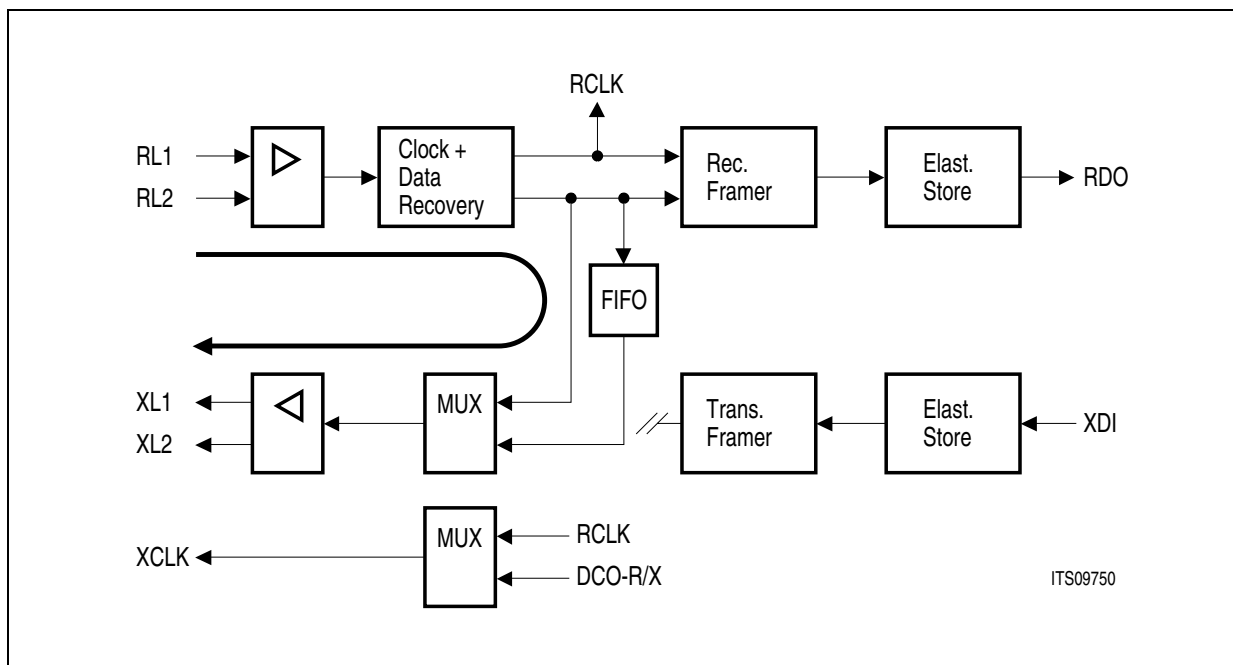

Figure 37 Remote Loop (E1)

4.6.3 Payload Loop-Back

To perform an effective circuit test a payload loop is implemented. The payload loop-back (FMR2.PLB) loops the data stream from the receiver section back to transmitter section. The looped data passes the complete receiver including the wander and jitter compensation in the receive elastic store and is output on pin RDO. Instead of the data an AIS signal (FMR2.SAIS) can be sent to the system interface.

The framing bits, CRC4 and spare bits are not looped, if XSP.TT0 = 0. They are generated by the FALC56 transmitter. If the PLB is enabled the transmitter and the data on pins XL1/2 or XDOP/XDON are clocked with SCLKR instead of SCLKX. If XSP.TT0 = 1 the received time slot 0 is sent back transparently to the line interface. Data on the following pins is ignored: XDI, XSIG, SCLKX, $\overline{\text{SYPX}}$ and XMFS. All the received data is processed normally.

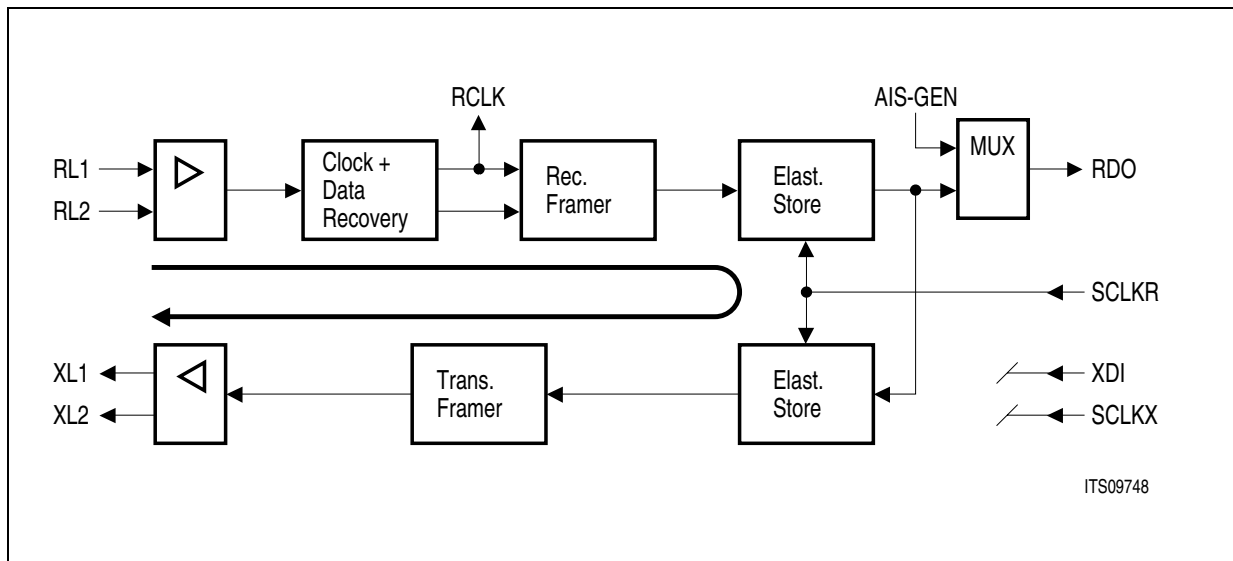

Figure 38 Payload Loop (E1)

4.6.4 Local Loop

The local loop-back mode selected by LIM0.LL = 1 disconnects the receive lines RL1/2 or RDIP/RDIN from the receiver. Instead of the signals coming from the line the data provided by the system interface is routed through the analog receiver back to the system interface. However, the bit stream is transmitted undisturbedly on the line. However, an AIS to the distant end can be enabled by setting FMR1.XAIS = 1 without influencing the data looped back to the system interface.

Note that enabling the local loop usually invokes an out-of-frame error until the receiver resynchronizes to the new framing. The serial codes for transmitter and receiver have to be identical.

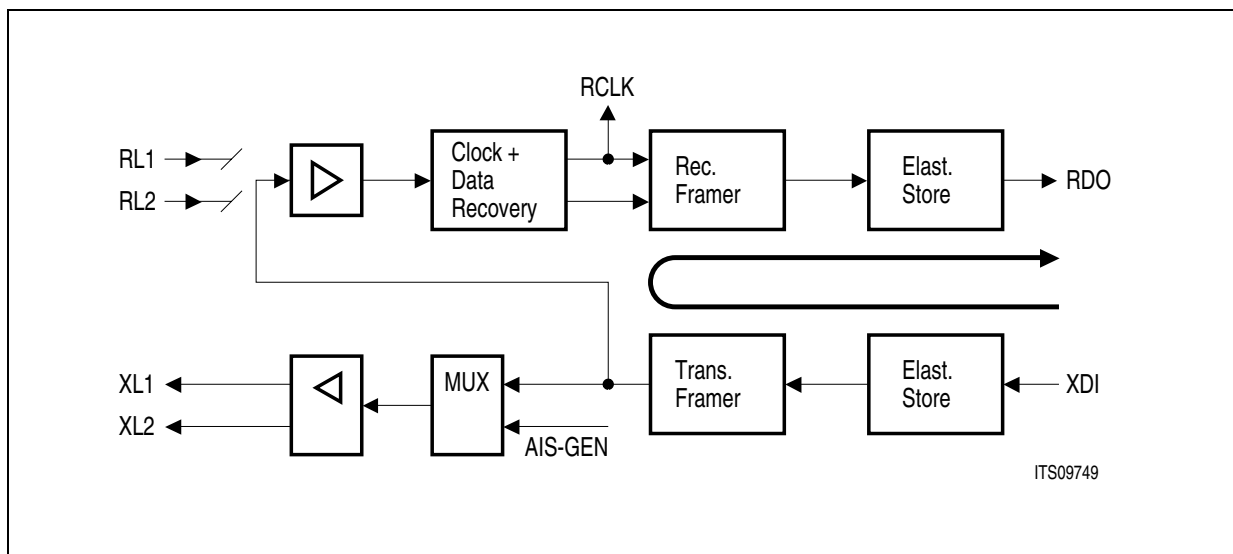

Figure 39 Local Loop (E1)

4.6.5 Single Channel Loop-Back

Each of the 32 time slots can be selected for loop-back from the system PCM input (XDI) to the system PCM output (RDO). This loop-back is programmed for one time slot at a time selected by register LOOP. During loop-back, an idle channel code programmed in register IDLE is transmitted to the remote end in the corresponding PCM route time slot.

For the time slot test, sending sequences of test patterns like a 1-kHz check signal shall be avoided. Otherwise an increased occurrence of slips in the tested time slot disturbs testing. These slips do not influence the other time slots and the function of the receive memory. The usage of a quasi-static test pattern is recommended.

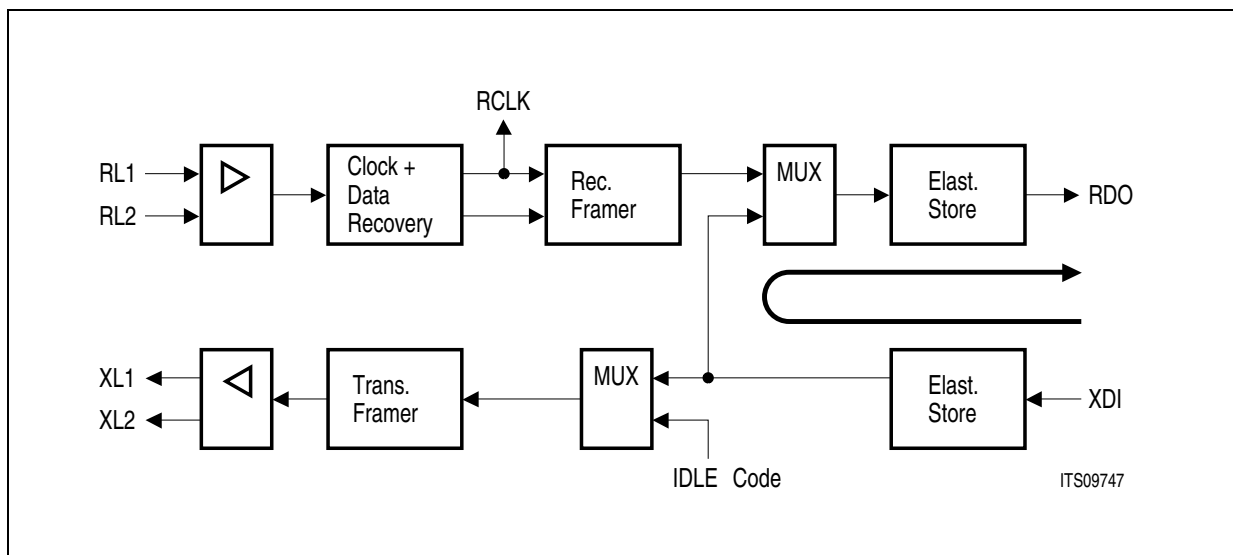

Figure 40 Single Channel Loop-Back (E1)

4.6.6 Alarm Simulation (E1)

Alarm simulation does not affect the normal operation of the device, i.e. all time slots remain available for transmission. However, possible real alarm conditions are not reported to the processor or to the remote end when the device is in the alarm simulation mode.

The alarm simulation is initiated by setting the bit FMR0.SIM. The following alarms are simulated:

- Loss-Of-Signal (LOS)
- Alarm Indication Signal (AIS)
- Loss of pulse frame
- Remote alarm indication
- Receive and transmit slip indication
- Framing error counter
- Code violation counter (HDB3 Code)
- CRC4 error counter
- E-Bit error counter
- CEC2 counter
- CEC3 counter

Some of the above indications are only simulated if the FALC56 is configured to a mode where the alarm is applicable (e.g. no CRC4 error simulation when doubleframe format is enabled).

Setting of the bit FMR0.SIM initiates alarm simulation, interrupt status bits are set. Error counting and indication occurs while this bit is set. After it is reset all simulated error conditions disappear, but the generated interrupt statuses are still pending until the corresponding interrupt status register is read. Alarms like AIS and LOS are cleared automatically. Interrupt status registers and error counters are automatically cleared on read.

4.6.7 Single Bit Defect Insertion

Single bit defects can be inserted into the transmit data stream for the following functions:

FAS defect, multiframe defect, CRC defect, CAS defect, PRBS defect and bipolar violation.

Defect insertion is controlled by register IERR.

5 Functional Description T1/J1

5.1 Receive Path in T1/J1 Mode

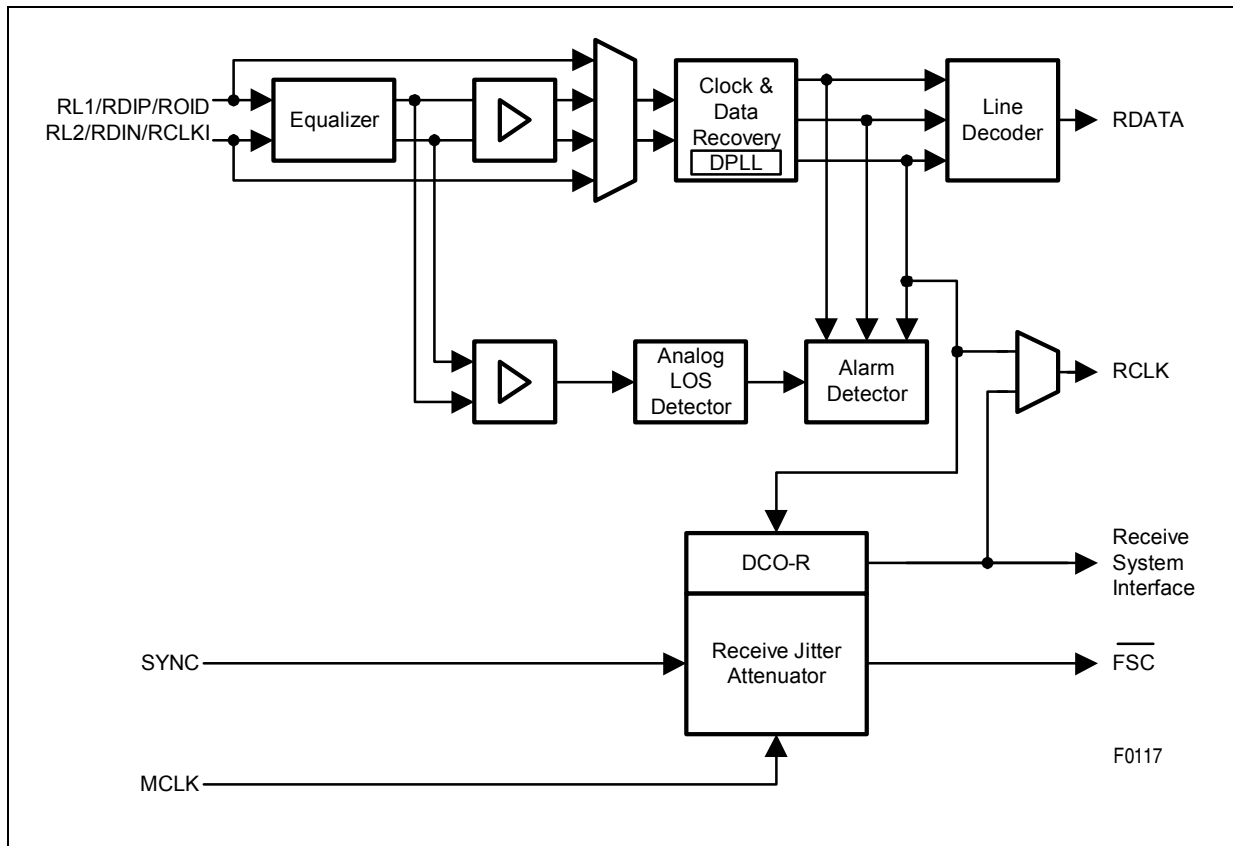

Figure 41 Receive Clock System (T1/J1)

5.1.1 Receive Line Interface (T1/J1)

For data input, three different data types are supported:

- Ternary coded signals received at multifunction ports RL1 and RL2 from a -36 dB ternary interface. The ternary interface is selected if LIM1.DRS is reset.
- Digital dual-rail signals received on ports RDIP and RDIN. The dual-rail interface is selected if LIM1.DRS and FMR0.RC1 is set.
- Unipolar data on port ROID received from a fiber-optical interface. The optical interface is selected if LIM1.DRS is set and FMR0.RC1 is reset.

5.1.2 Receive Short and Long-Haul Interface (T1/J1)

The FALC56 has an integrated short-haul and long-haul line interface, including a receive equalization network, noise filtering and programmable line build-outs (LBO).

5.1.3 Receive Equalization Network (T1/J1)

The FALC56 automatically recovers the signals received on pins RL1/2. The maximum reachable length with a 22 AWG twisted-pair cable is 2000 m (~6560 ft.). After reset the FALC56 is in short-haul mode, received signals are recovered up to -10 dB of cable attenuation. Switching into long-haul mode is done by setting of bit LIM0.EQON = 1. The integrated receive equalization network recovers signals with up to -36 dB of cable attenuation in long-haul mode. Noise filters eliminate the higher frequency part of the received signals. The incoming data is peak-detected and sliced to produce the digital data stream. The slicing level is software selectable in four steps (45%, 50%, 55%, 67%). The received data is then forwarded to the clock and data recovery unit.

5.1.4 Receive Line Attenuation Indication (T1/J1)

Status register RES reports the current receive line attenuation in a range from 0 to -36 dB in 25 steps of approximately 1.4 dB each. The least significant 5 bits of this register indicate the cable attenuation in dB. These 5 bits are only valid in combination with the most significant two bits (RES.EV1/0 = 01).

5.1.5 Receive Clock and Data Recovery (T1/J1)

The analog received signal on port RL1/2 is equalized and then peak-detected to produce a digital signal. The digital received signal on port RDIP/N is directly forwarded to the DPLL. The receive clock and data recovery extracts the route clock RCLK from the data stream received at the RL1/2, RDIP/RDIN or ROID lines and converts the data stream into a single-rail, unipolar bit stream. The clock and data recovery uses an internally generated high frequency clock based on MCLK.

The recovered route clock or a de-jittered clock can be output on pin RCLK as shown in [Table 25](#).

See also [Table 28](#) on page [126](#) for details of master/slave clocking.

Table 25 RCLK Output Selection (T1/J1)

Clock Source	RCLK Frequency			
		CMR1. DCS	CMR1. RS1/0	SIC2. SSC2
Receive Data (1.544 Mbit/s on RL1/RL2, RDIP/RDIN or ROID)	1.544 MHz	X	00	X
Receive Data in case of LOS	constant high	X	01	X
	1.544 MHz (generated by DCO-R, synchronized on SYNC)	1	10	1
DCO-R	1.544 MHz	X	10	1
	2.048 MHz	X	10	0
	6.176 MHz	X	11	1
	8.192 MHz	X	11	0

The intrinsic jitter generated in the absence of any input jitter is not more than 0.035 UI. In digital bipolar line interface mode the clock and data recovery requires HDB3 coded signals with 50% duty cycle.

5.1.6 Receive Line Coding (T1/J1)

The B8ZS line code or the AMI (ZCS, zero code suppression) coding is provided for the data received from the ternary or the dual-rail interface. All code violations that do not correspond to zero substitution rules are detected. The detected errors increment the code violation counter (16 bits length). In case of the optical interface a selection between the NRZ code and the CMI Code (1T2B) with B8ZS or AMI postprocessing is provided. If CMI code is selected the receive route clock is recovered from the data stream. The CMI decoder does not correct any errors. In case of NRZ coding data is latched with the falling edge RCLKI.

When using the optical interface with NRZ coding, the decoder is bypassed and no code violations are detected.

Additionally, the receive line interface contains the alarm detection for Alarm Indication Signal AIS (Blue Alarm) and the loss-of-signal LOS (Red Alarm).

The signal at the ternary interface is received at both ends of a transformer.

Functional Description T1/J1

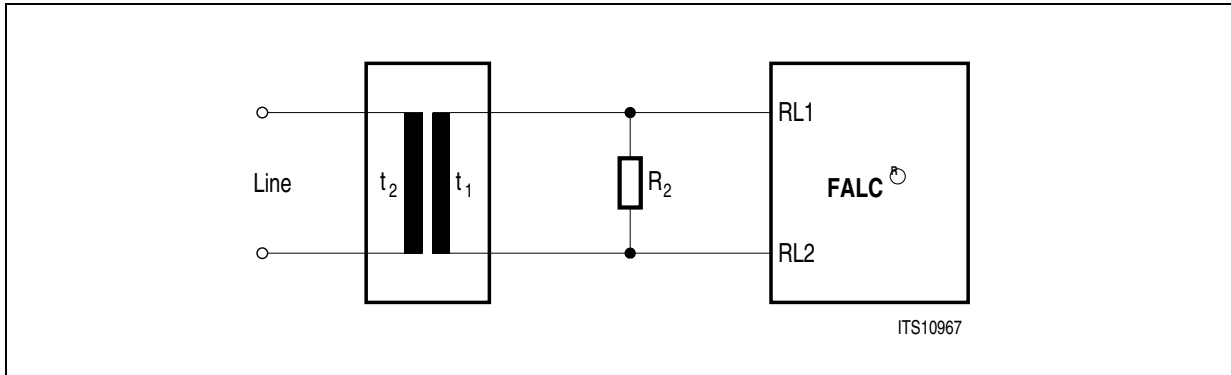

Figure 42 Receiver Configuration (T1/J1)

Table 26 Recommended Receiver Configuration Values (T1/J1)

Parameter ¹⁾	Characteristic Impedance [Ω]	
	T1	J1
$R_2 (\pm 1\%) [\Omega]$	100	110
$t_2 : t_1$	1 : 1	

¹⁾ This includes all parasitic effects caused by circuit board design.

5.1.7 Receive Line Monitoring Mode

For short-haul applications like shown in [Figure 43](#), the receive equalizer can be switched into receive line monitoring mode ($LIM0.RLM = 1$). One device is used as a short-haul receiver while the other is used as a short-haul monitor. In this mode the receiver sensitivity is increased to detect an incoming signal of -20 dB resistive attenuation. The required resistor values are given in [Table 27](#).

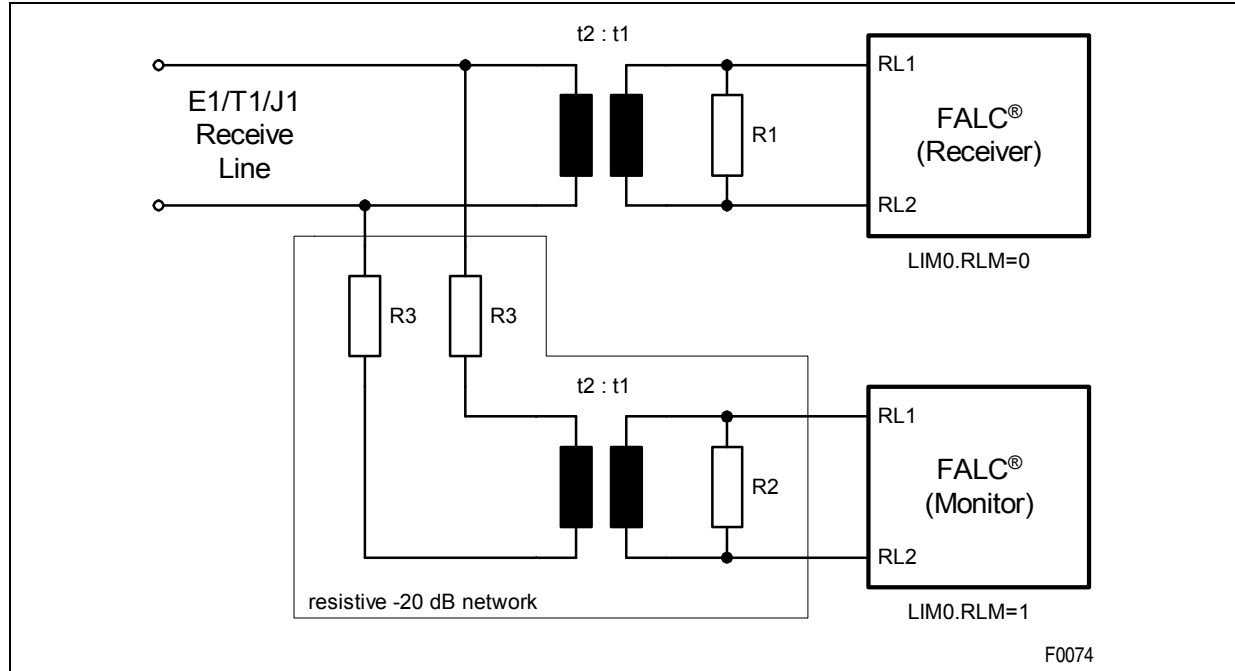

Figure 43 Receive Line Monitoring

Table 27 External Component Recommendations (Monitoring)

Parameter ¹⁾	Characteristic Impedance [Ω]	
	T1	J1
	100	110
R_1 ($\pm 1\%$) [Ω]	100	110
R_2 ($\pm 1\%$) [Ω]	100	110
R_3 ($\pm 1\%$) [Ω]	430	470
$t_2 : t_1$	1 : 1	1 : 1

¹⁾ This includes all parasitic effects caused by circuit board design.

Using the receive line monitor mode and the hardware tristate function of transmit lines XL1/2, the FALC56 now supports applications connecting two devices to one receive

Functional Description T1/J1

and transmission line. In these kind of applications both devices are working in parallel for redundancy purpose (see [Figure 44](#)). While one of them is driving the line, the other one must be switched into transmit line tristate mode. If both channels are configured identically and supplied with the same system data and clocks, the transmit path can be switched from one channel to the other without causing a synchronization loss at the remote end.

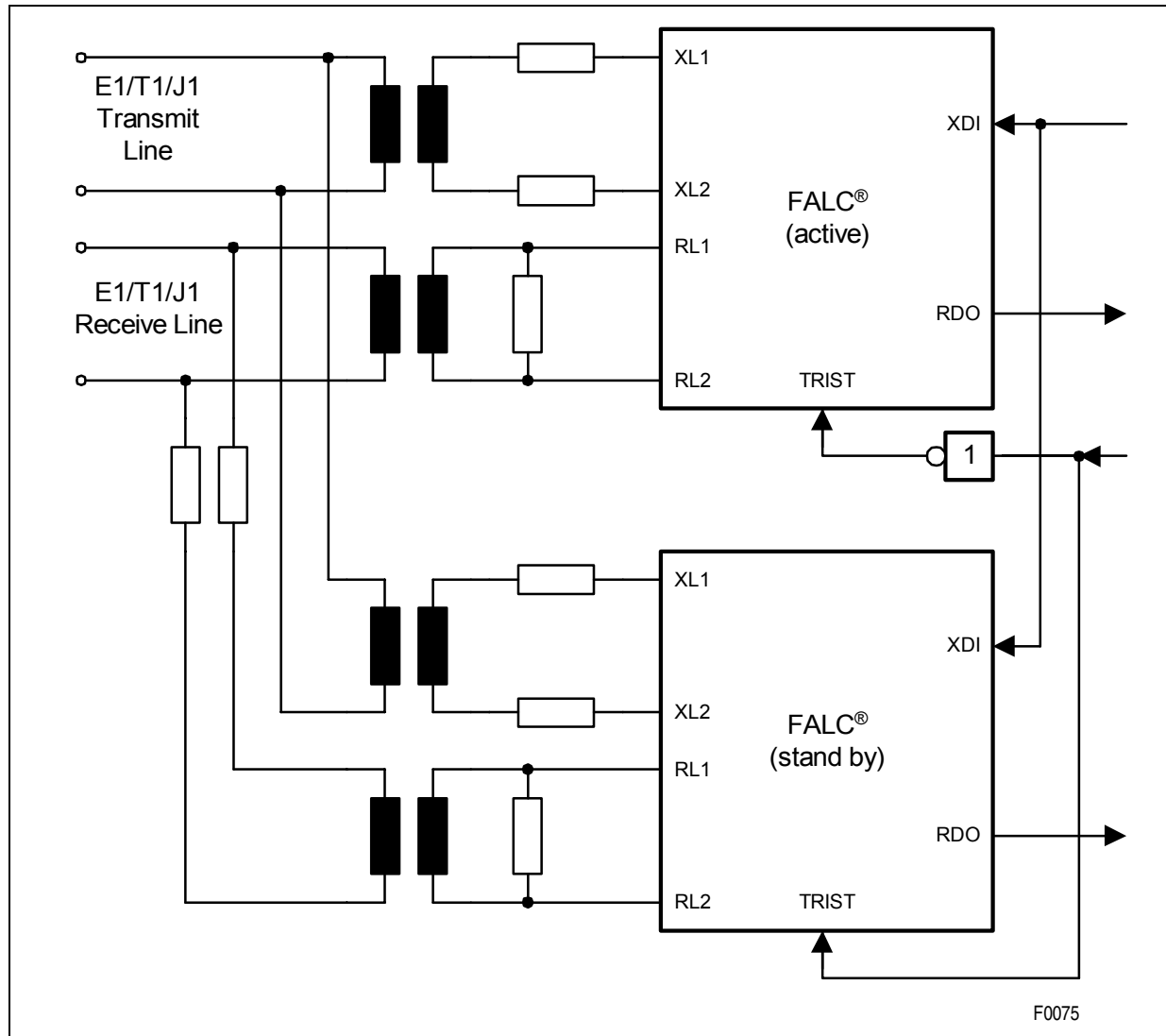

Figure 44 Protection Switching Application

5.1.8 Loss-of-Signal Detection (T1/J1)

There are different definitions for detecting Loss-Of-Signal alarms (LOS) in the ITU-T G.775 and AT&T TR 54016. The FALC56 covers all these standards. The LOS indication is performed by generating an interrupt (if not masked) and activating a status bit. Additionally a LOS status change interrupt is programmable by register GCR.SCI.

Functional Description T1/J1

- **Detection:**
An alarm is generated if the incoming data stream has no pulses (no transitions) for a certain number (N) of consecutive pulse periods. "No pulse" in the digital receive interface means a logical zero on pins RDIP/RDIN or ROID. A pulse with an amplitude less than Q dB below nominal is the criteria for "no pulse" in the analog receive interface (LIM1.DRS = 0). The receive signal level Q is programmable by three control bits LIM1.RIL(2:0) (see [Chapter 11.3](#) on page 447). The number N is set by an 8 bit register (PCD). The contents of the PCD register is multiplied by 16, which results in the number of pulse periods, i.e. the time which has to suspend until the alarm has to be detected. The programmable range is 16 to 4096 pulse periods.
- **Recovery:**
In general the recovery procedure starts after detecting a logical "1" (digital receive interface) or a pulse (analog receive interface) with an amplitude more than Q dB (defined by LIM1.RIL(2:0)) of the nominal pulse. The value in the 8 bit register PCR defines the number of pulses (1 to 255) to clear the LOS alarm. Additional recovery conditions are programmed by register LIM2.

If a loss-of-signal condition is detected in long-haul mode, the data stream can optionally be cleared automatically to avoid bit errors before LOS is indicated. The selection is done by LIM1.CLOS = 1.

5.1.9 Receive Jitter Attenuator (T1/J1)

The receive jitter attenuator is placed in the receive path. The working clock is an internally generated high frequency clock based on the clock provided on pin MCLK. The jitter attenuator meets the requirements of PUB 62411, PUB 43802, TR-TSY 009, TR-TSY 253, TR-TSY 499 and ITU-T I.431, G.703 and G. 824.

The internal PLL circuitry DCO-R generates a "jitter-free" output clock which is directly depending on the phase difference of the incoming clock and the jitter attenuated clock. The receive jitter attenuator can be synchronized either on the extracted receive clock RCLK or on a 1.544-, 2.048-MHz or 8-kHz clock provided on pin SYNC (8 kHz in master mode only). The received data is written into the receive elastic buffer with RCLK and are read out with the de-jittered clock sourced by DCO-R. The jitter attenuated clock can be output on pins RCLK, CLK1 or SCLKR. Optionally an 8-kHz clock is provided on pin SEC/FSC.

The DCO-R circuitry attenuates the incoming jittered clock starting at 6-Hz jitter frequency with 20 dB per decade fall-off. Wander with a jitter frequency below 6 Hz is passed unattenuated. The intrinsic jitter in the absence of any input jitter is < 0.02 UI.

For some applications it might be useful starting of jitter attenuation at lower frequencies. Therefore the corner frequency is switchable by the factor of ten down to 0.6 Hz (LIM2.SCF).

The DCO-R circuitry is automatically centered to the nominal bit rate if the reference clock on pin SYNC/RCLK is missed for 2, 3 or 4 of the 2.048-MHz or 1.544-MHz clock

Functional Description T1/J1

periods. This center function of DCO-R can be optionally disabled (CMR2.DCF = 1) in order to accept a gapped reference clock.

In analog line interface mode the RCLK is always running. Only in digital line interface mode with single-rail data (NRZ) a gapped clock on pin RCLK can occur.

The receive jitter attenuator works in two different modes:

- **Slave mode**
In slave mode (LIM0.MAS = 0) the DCO-R is synchronized on the recovered route clock. In case of LOS the DCO-R switches automatically to master mode. If bit CMR1.DCS is set automatic switching from RCLK to SYNC is disabled.
- **Master mode**
In master mode (LIM0.MAS = 1) the jitter attenuator is in free running mode if no clock is supplied on pin SYNC. If an external clock on the SYNC input is applied, the DCO-R synchronizes to this input. The external frequency can be 1.544 MHz (LIM1.DCOC = 0; IPC.SSYF = 0), 2.048 MHz (LIM1.DCOC = 1; IPC.SSYF = 0) or 8.0 kHz (IPC.SSYF = 1; LIM1.DCOC = don't care).

The following table shows the clock modes with the corresponding synchronization sources.

Table 28 System Clocking (T1/J1)

Mode	Internal LOS Active	SYNC Input	System Clocks
Master	independent	Fixed to V_{DD}	DCO-R centered, if CMR2.DCF = 0. (CMR2.DCF should not be set)
Master	independent	1.544 MHz	Synchronized on SYNC input (external 1.544 MHz, IPC.SSYF = 0, LIM1.DCOC = 0)
Master	independent	2.048 MHz	Synchronized on SYNC input (external 2.048 MHz, IPC.SSYF = 0, LIM1.DCOC = 1)
Master	independent	8.0 kHz	Synchronized on SYNC input (external 8.0 kHz, IPC.SSYF = 1, CMR2.DCF = 0)
Slave	no	Fixed to V_{DD}	Synchronized on line RCLK
Slave	no	1.544 or 2.048 MHz	Synchronized on line RCLK

Functional Description T1/J1

Table 28 System Clocking (T1/J1) (cont'd)

Mode	Internal LOS Active	SYNC Input	System Clocks
Slave	yes	Fixed to V_{DD}	CMR1.DCS = 0: DCO-R is centered, if CMR2.DCF = 0. (CMR2.DCF should not be set)
			CMR1.DCS = 1: Synchronized on line RCLK
Slave	yes	1.544 or 2.048 MHz	CMR1.DCS = 0: Synchronized on SYNC input (external 1.544 or 2.048 MHz)
			CMR1.DCS = 1: Synchronized on line clock RCLK

The jitter attenuator meets the jitter transfer requirements of the PUB 62411, PUB 43802, TR-TSY 009, TR-TSY 253, TR-TSY 499 and ITU-T I.431 and G.703 (refer to **Figure 45**).

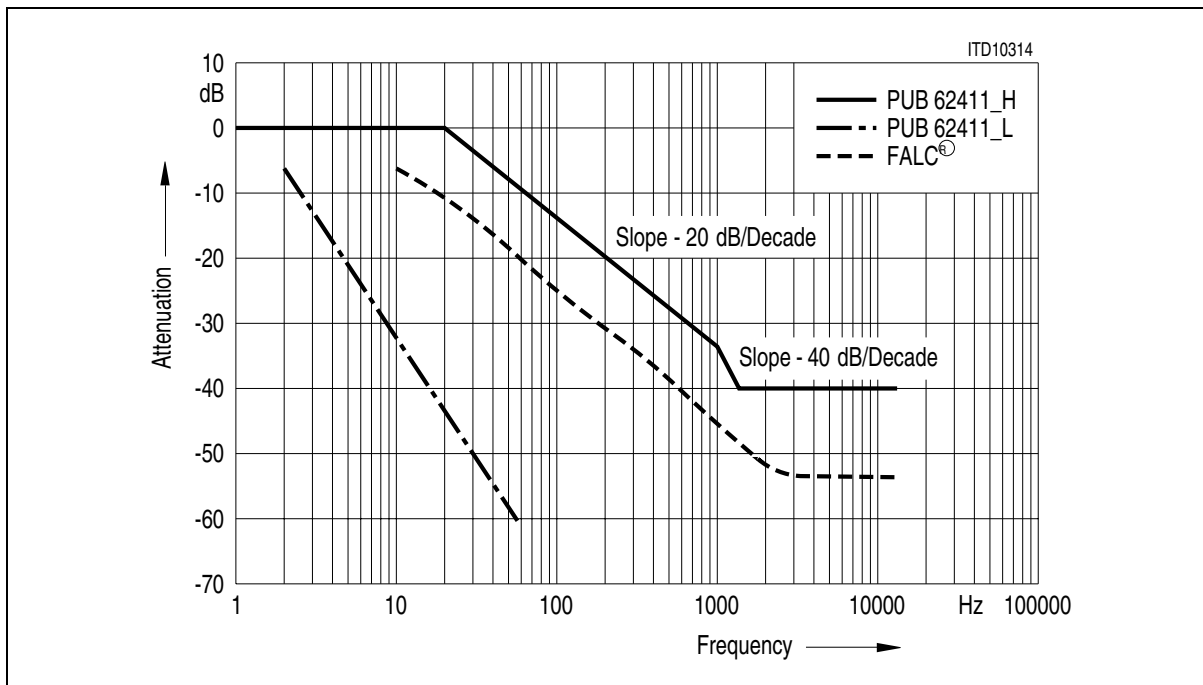

Figure 45 Jitter Attenuation Performance (T1/J1)

5.1.10 Jitter Tolerance (T1/J1)

The FALC56 receiver's tolerance to input jitter complies with ITU, AT&T and Telcordia requirements for T1 applications.

Figure 46 shows the curves of different input jitter specifications stated below as well as the FALC56 performance.

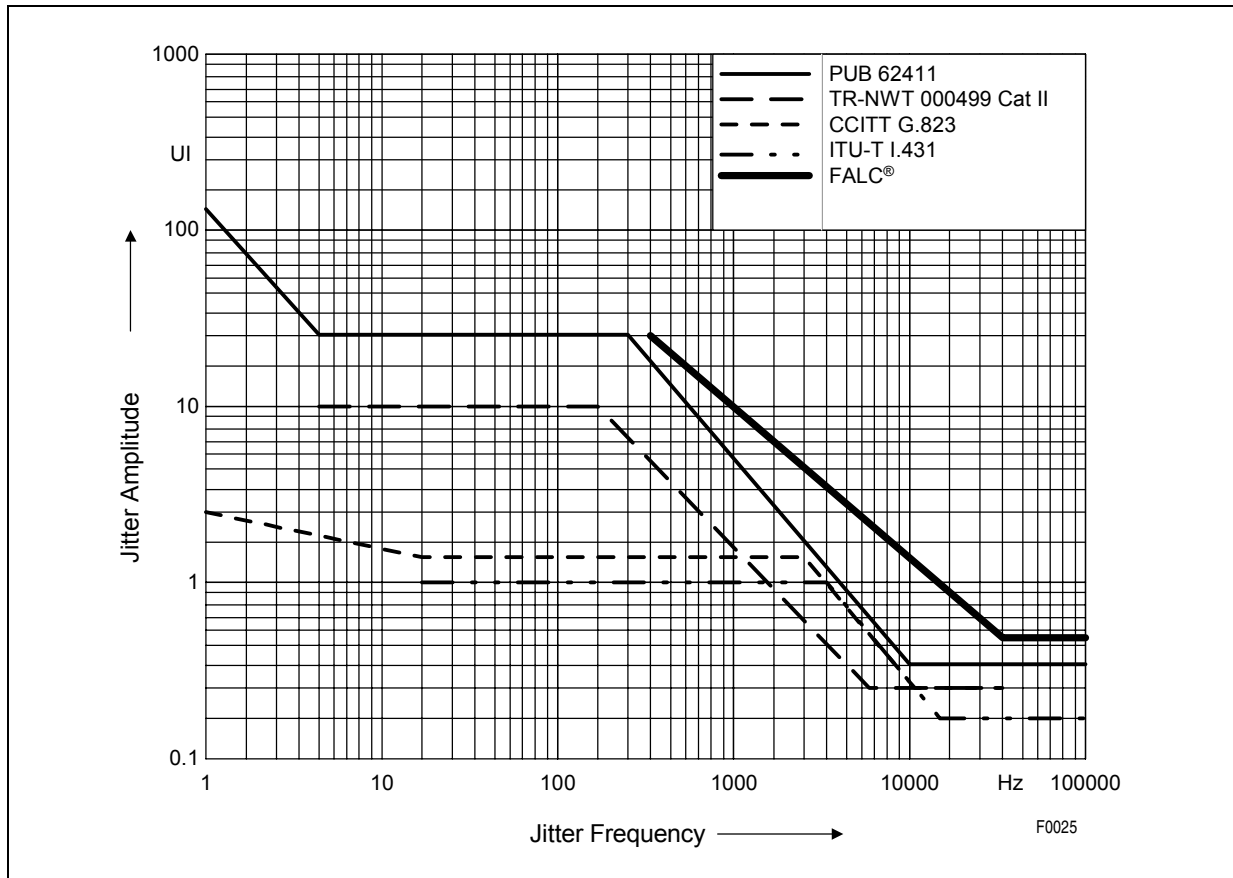

Figure 46 Jitter Tolerance (T1/J1)

5.1.11 Output Jitter (T1/J1)

According to the input jitter defined by PUB62411 the FALC56 generates the output jitter, which is specified in [Table 29](#) below.

Table 29 Output Jitter (T1/J1)

Specification	Measurement Filter Bandwidth		Output Jitter (UI peak to peak)
	Lower Cutoff	Upper Cutoff	
PUB 62411	10 Hz	8 kHz	< 0.015
	8 kHz	40 kHz	< 0.015
	10 Hz	40 kHz	< 0.015
	Broadband		< 0.02

5.1.12 Framing/Synchronizer (T1/J1)

The following functions are performed:

- Synchronization on pulse frame and multiframe
- Error indication when synchronization is lost. In this case, AIS is sent to the system side automatically and remote alarm to the remote end if enabled.
- Initiating and controlling of resynchronization after reaching the asynchronous state. This is done automatically by the FALC56 or user controlled by the microprocessor interface.
- Detection of remote alarm (yellow alarm) indication from the incoming data stream.
- Separation of service bits and data link bits. This information is stored in special status registers.
- Detection of framed or unframed in-band loop-up/-down code
- Generation of various maskable interrupt statuses of the receiver functions.
- Generation of control signals to synchronize the CRC checker, and the receive elastic buffer.

If programmed and applicable to the selected multiframe format, CRC checking of the incoming data stream is done by generating check bits for a CRC multiframe according to the CRC6 procedure (refer to ITU-T G.704). These bits are compared with those check bits that are received during the next CRC multiframe. If there is at least one mismatch, the CRC error counter (16 bit) is incremented.

5.1.13 Receive Elastic Buffer (T1/J1)

The received bit stream is stored in the receive elastic buffer. The memory is organized as a two-frame elastic buffer with a maximum size of 2×193 bit. The size of the elastic buffer is configured independently for the receive and transmit direction. Programming of the receive buffer size is done by SIC1.RBS1/0:

Functional Description T1/J1

- RBS1/0 = 00: two frame buffer or 386 bits
Maximum of wander amplitude (peak-to-peak): (1 UI = 648 ns)
System interface clocking rate: modulo 2.048 MHz:
142 UI in channel translation mode 0
78 UI in channel translation mode 1
System interface clocking rate: modulo 1.544 MHz:
Maximum of wander: 140 UI
average delay after performing a slip: 1 frame or 193 bits
- RBS1/0 = 01: one frame buffer or 193 bits
System interface clocking rate: modulo 2.048 MHz:
Maximum of wander: 70 UI in channel translation mode 0
Maximum of wander: 50 UI in channel translation mode 1
System interface clocking rate: modulo 1.544 MHz:
Maximum of wander: 74 UI
average delay after performing a slip: 96 bits
- RBS1/0 = 10: short buffer or 96 bits
System interface clocking rate: modulo 2.048 MHz:
Maximum of wander: 28 UI in channel translation mode 0; channel translation mode 1 not supported
System interface clocking rate: modulo 1.544 MHz:
Maximum of wander: 38 UI
average delay after performing a slip: 48 bits
- RBS1/0 = 11: Bypass of the receive elastic buffer

The functions are:

- Clock adaption between system clock (SCLKR) and internally generated route clock (RCLK).
- Compensation of input wander and jitter.
- Frame alignment between system frame and receive route frame
- Reporting and controlling of slips

Controlled by special signals generated by the receiver, the unipolar bit stream is converted into bit-parallel, time slot serial data which is circularly written to the elastic buffer using internally generated Receive Route Clock (RCLK).

Reading of stored data is controlled by the system clock sourced by SCLKR or by the receive jitter attenuator and the synchronization pulse ($\overline{\text{SYPR}}$) together with the programmed offset values for the receive time slot/clock slot counters. After conversion into a serial data stream, the data is sent out on port RDO. If the receive buffer is bypassed programming of the time slot offset is disabled and data is clocked off with RCLK instead of SCLKR.

Functional Description T1/J1

The 24 received time slots (T1/J1) can be translated into the 32 system time slots (E1) in two different channel translation modes (FMR1.CTM). Unequipped time slots are set to FF_H . See [Table 30](#).

Table 30 Channel Translation Modes (DS1/J1)

Channels		Time Slots	Channels		Time Slots
Channel Translation Mode 0	Channel Translation Mode 1		Channel Translation Mode 0	Channel Translation Mode 1	
FS/DL	FS/DL	0	–	16	16
1	1	1	13	17	17
2	2	2	14	18	18
3	3	3	15	19	19
–	4	4	–	20	20
4	5	5	16	21	21
5	6	6	17	22	22
6	7	7	18	23	23
–	8	8	–	24	24
7	9	9	19	–	25
8	10	10	20	–	26
9	11	11	21	–	27
–	12	12	–	–	28
10	13	13	22	–	29
11	14	14	23	–	30
12	15	15	24	–	31

– : FF_H

In one frame or short buffer mode the delay through the receive buffer is reduced to an average delay of 96 or 48 bits. In bypass mode the time slot assigner is disabled. In this case $SYPR$ programmed as input is ignored. Slips are performed in all buffer modes except the bypass mode. After a slip is detected the read pointer is adjusted to one half of the current buffer size.

The following table gives an overview of the receive buffer operating mode.

Table 31 Receive Buffer Operation Modes (T1/J1)

Buffer Size (SIC1.RBS1/0)	TS Offset program. (RC1/0) + SYPR = input	Slip perform.
bypass ¹⁾	disabled	no
short buffer	not recommended, recommended: SYPR = output	yes
1 frame	not recommended, recommended: SYPR = output	yes
2 frames	enabled	yes

¹⁾ In bypass mode the clock provided on pin SCLKR is ignored. Clocking is done with RCLK.

Figure 47 gives an idea of operation of the receive elastic buffer:

A slip condition is detected when the write pointer (W) and the read pointer (R) of the memory are nearly coincident, i.e. the read pointer is within the slip limits (S +, S -). If a slip condition is detected, a negative slip (one frame or one half of the current buffer size is skipped) or a positive slip (one frame or one half of the current buffer size is read out twice) is performed at the system interface, depending on the difference between RCLK and the current working clock of the receive backplane interface, i.e. on the position of pointer R and W within the memory. A positive/negative slip is indicated by the interrupt status bits ISR3.RSP and ISR3.RSN.

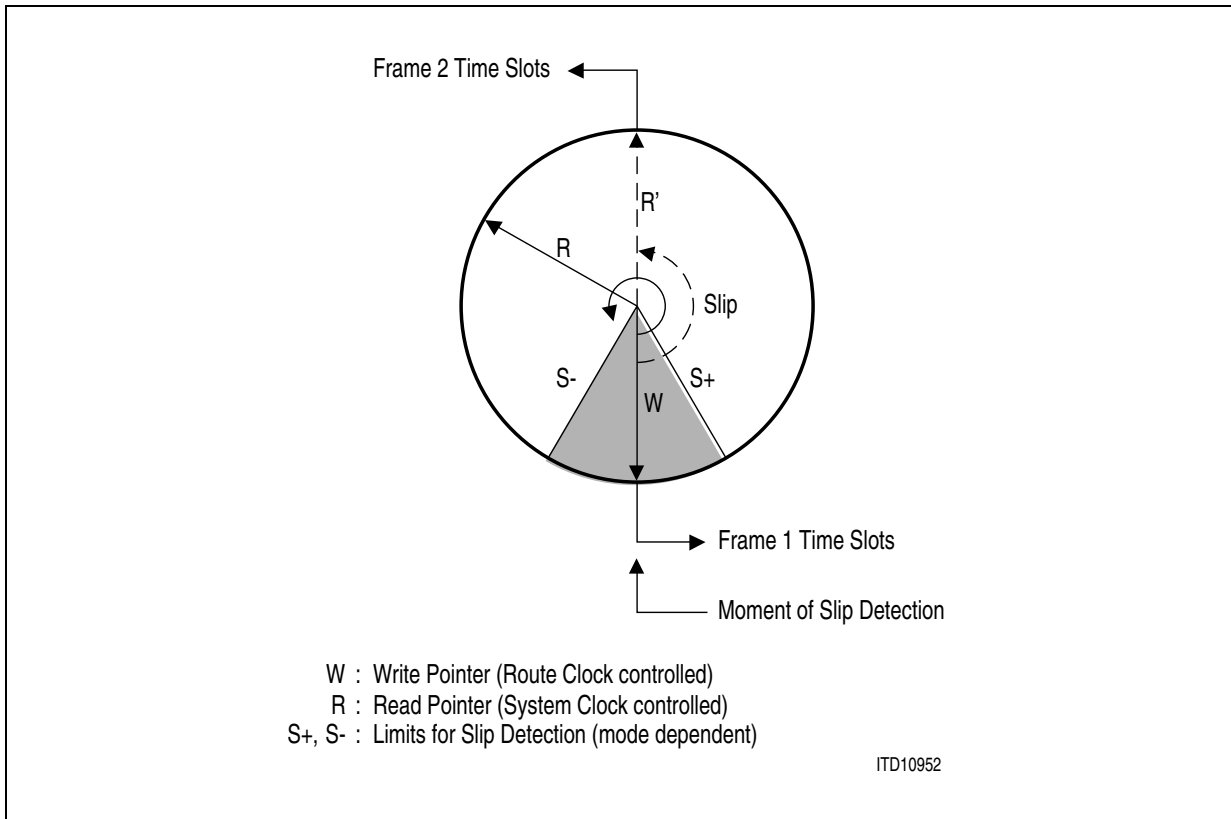

Figure 47 The Receive Elastic Buffer as Circularly Organized Memory

5.1.14 Receive Signaling Controller (T1/J1)

The signaling controller can be programmed to operate in various signaling modes. The FALC56 performs the following signaling and data link methods.

5.1.14.1 HDLC or LAPD access

The FALC56 offers three independent HDLC channels. All of them provide the following features:

- 64 byte receive FIFO for each channel
- 64 byte transmit FIFO for each channel
- transmission in one of 24 time slots
(time slot number programmable for each channel individually)
- transmission in even frames only, odd frames only or both
(programmable for each channel individually)
- bit positions to be used in selected time slots are maskable
(any bit position can be enabled for each channel individually)
- HDLC or transparent mode
- flag detection
- CRC checking
- bit-stuffing
- flexible address recognition (1 byte, 2 bytes)
- C/R bit processing (according to LAPD protocol)

In addition to this, HDLC channel 1 provides:

- SS7 support
- BOM (bit oriented message) support
- flexibility to insert and extract data during certain time slots, any combination of time slots can be programmed independently for the receive and transmit direction

In case of common channel signaling the signaling procedure HDLC/SDLC or LAPD according to Q.921 is supported. The signaling controller of the FALC56 performs the flag detection, CRC checking, address comparison and zero bit removing. The received data flow and the address recognition features can be performed in very flexible way, to satisfy almost any practical requirements. Depending on the selected address mode, the FALC56 performs a 1 or 2-byte address recognition. If a 2-byte address field is selected, the high address byte is compared with the fixed value FEH or FCH (group address) as well as with two individually programmable values in RAH1 and RAH2 registers. According to the ISDN LAPD protocol, bit 1 of the high byte address is interpreted as command/response bit (C/R) and is excluded from the address comparison. Buffering of receive data is done in a 64 byte deep RFIFO.

In signaling controller transparent mode, fully transparent data reception without HDLC

Functional Description T1/J1

framing is performed, i.e. without flag recognition, CRC checking or bit stuffing. This allows user specific protocol variations.

5.1.14.2 Support of Signaling System #7

The HDLC controller of channel 1 supports the signaling system #7 (SS7) which is described in ITU-Q.703. The following description assumes, that the reader is familiar with the SS7 protocol definition.

SS7 support must be activated by setting the MODE register. The SS7 protocol is supported by the following hardware features in receive mode:

- all Signaling Units (SU) are stored in the receive FIFO (RFIFO)
- detecting of flags from the incoming data stream
- bit stuffing (zero deletion)
- checking of seven or more consecutive ones in the receive data stream
- checking if the received Signaling Unit is a multiple of eight bits and at least six octets including the opening flag
- calculation of the CRC16 checksum:
In receive direction the calculated checksum is compared to the received one; errors are reported in register RSIS.
- checking if the signal information field of a received signaling unit consists of more than 272 octets, in this case the current signaling unit is discarded.

In order to reduce the microprocessor load, fill In signaling units (FISUs) are processed automatically. By examining the length indicator of a received signal unit the FALC56 decides whether a FISU has been received. Consecutively received FISUs are compared and optionally not stored in the receive FIFO (RFIFO, 2×32 bytes), if the contents is equal to the previous one. The same applies to link status signaling units, if bit CCR5.CSF is set. The different types of signaling units as message signaling unit (MSU), link status signaling unit (LSSU) and fill in signaling units (FISU) are indicated in the RSIS register, which is automatically added to the RFIFO with each received signaling unit. The complete signaling unit except start and end flags is stored in the receive FIFO. The functions of bits CCR1.RCRC and CCR1.RADD are still valid in SS7 mode. Errored signaling units are handled automatically according to ITU-T Q.703 as shown in **Figure 20**. SU counter (su) and errored SU counter (C_s) are reset by setting CMDR2.RSUC. The error threshold T can be selected to be 64 (default) or 32 by setting/clearing bit CCR5.SUET. If the defined error limit is exceeded, an interrupt (ISR1.SUEX) is generated, if not masked by IMR1.SUEX = 1.

Note: If SUEX is caused by an aborted/invalid frame, the interrupt will be issued regularly until a valid frame is received (e.g. a FISU).

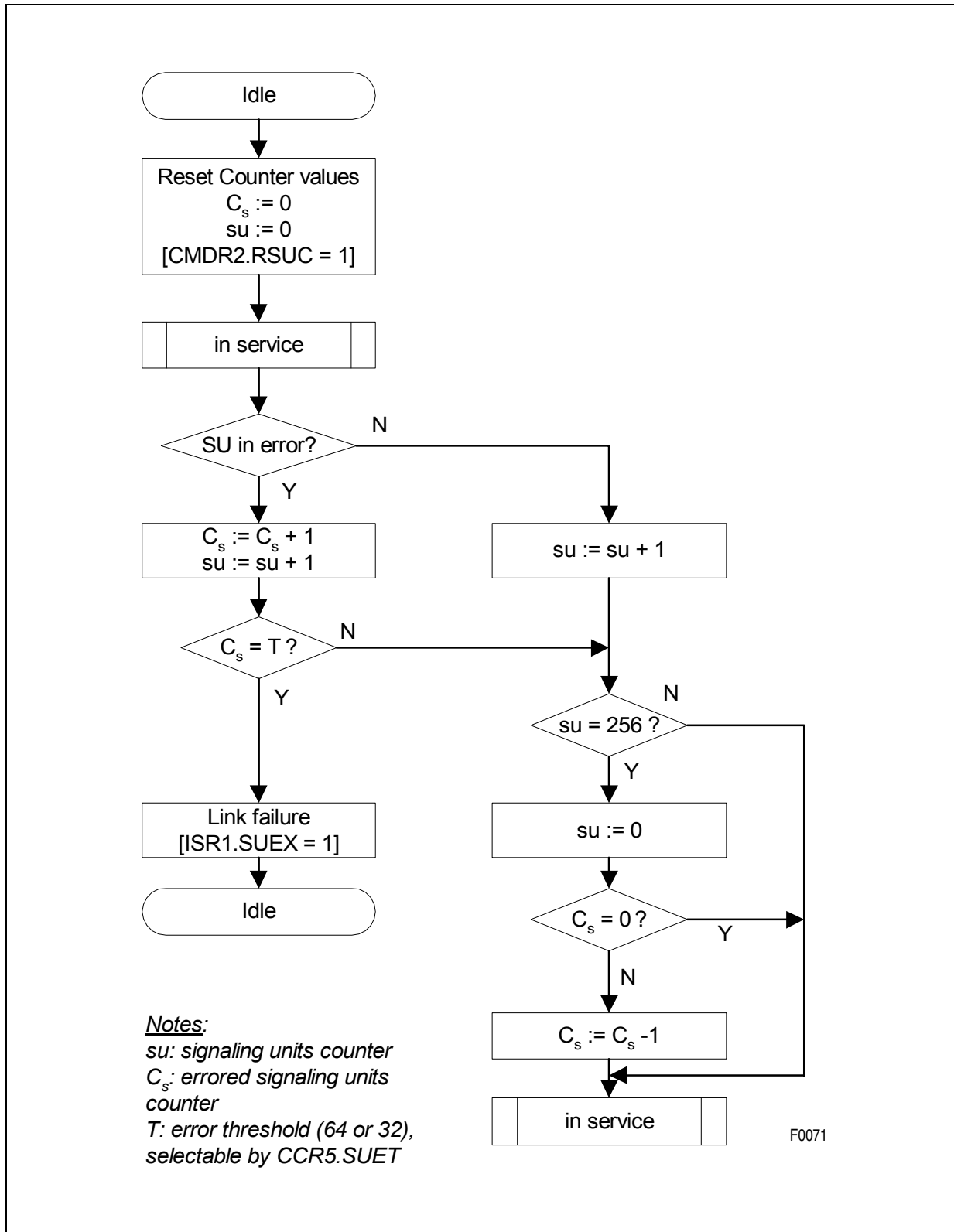

Figure 48 Automatic Handling of Errored Signaling Units

5.1.14.3 CAS Bit-Robbing (T1/J1, serial mode)

The signaling information is carried in the LSB of every sixth frame for each time slot. The signaling controller samples the bit stream either on the receive line side or if external signaling is enabled on the receive system side on port RSIG. Receive signaling data is stored in the registers RS(12:1).

Optionally the complete CAS multiframe is transmitted on pin RSIG (FMR5.EIBR = 1). The signaling data is clocked out with the working clock of the receive highway (SCLKR) together with the receive synchronization pulse ($\overline{\text{SYPR}}$). Data on RSIG is transmitted in the last 4 bits per time slot and are time slot aligned to the data on RDO. In ESF format the A,B,C,D bits are placed in the bit positions 5 to 8 per time slot. In F12/72 format the A and B bits are repeated in the C and D bit positions. The first 4 bits per time slot can be optionally fixed high or low. The FS/DL time slot is transmitted on RDO and RSIG. During idle time slots no signaling information is transmitted. Data on RSIG are only valid if the freeze signaling status is inactive. With FMR2.SAIS all-ones data is transmitted on RDO and RSIG.

Updating of the received signaling information is controlled by the freeze signaling status. The freeze signaling status is automatically activated if a loss-of-signal, or a loss-of-frame-alignment or a receive slip occurs. The current freeze status is output on port FREEZE (RP(A:D)) and indicated by register SIS.SFS. If SIS.SFS is active updating of the registers RS(12:1) is disabled. Optionally automatic freeze signaling is disabled by setting bit SIC3.DAF.

After CAS resynchronization an interrupt is generated. Because at this time the signaling is still frozen, CAS data is not valid yet. Readout of CAS data has to be delayed until the next CAS multiframe is received.

5.1.14.4 CAS Bit-Robbing (T1/J1, μ P access mode)

The signaling information is carried in the LSB of every sixth frame for each time slot. Receive data is stored in registers RS(12:1) aligned to the CAS multiframe boundary.

To relieve the μ P load from always reading the complete RS(12:1) buffer every 3 ms the FALC56 notifies the μ P by interrupt ISR0.RSC only when signaling changes from one multiframe to the next. Additionally the FALC56 generates a receive signaling data change pointer (RSP1/2) which directly points to the updated RS(12:1) register.

Because the CAS controller is working on the PCM highway side of the receive buffer, slips disturb the CAS data.

5.1.14.5 Bit Oriented Messages in ESF-DL Channel (T1/J1)

The FALC56 HDLC channel 1 supports the DL-channel protocol for ESF format according to ANSI T1.403 specification or according to AT&T TR54016. The HDLC and bit oriented message (BOM) receiver are switched on/off independently. If the FALC56 is used for HDLC formats only, the BOM receiver has to be switched off. If HDLC and

Functional Description T1/J1

BOM receiver have been switched on (MODE.HRAC/BRAC), an automatic switching between HDLC and BOM mode is enabled. If eight or more consecutive ones are detected, the BOM mode is entered. Upon detection of a flag in the data stream, the FALC56 switches back to HDLC mode. In BOM mode, the following byte format is assumed (the left most bit is received first): 111111110xxxxxx0

Three different BOM reception modes can be programmed (CCR1.BRM+ CCR2.RBFE). If CCR2.RBFE is set, the BOM receiver accepts only BOM frames after detecting 7 out of 10 equal BOM pattern. Buffering of receive data is done in a 64 byte deep RFIFO.

5.1.14.6 4 kbit/s Data Link Access in F72 Format (T1/J1)

The DL-channel protocol is supported as follows:

- access is done on a multiframe basis through registers RDL(3:1),
- the DL-bit information from frame 26 to 72 is stored in the receive FIFO of the signaling controller.

5.2 Framer Operating Modes (T1/J1)

5.2.1 General

Activated with bit FMR1.PMOD = 1.

PCM line bit rate	:	1.544 Mbit/s
Single frame length	:	193 bit, No. 1...193
Framing frequency	:	8 kHz
Organization	:	24 time slots, No. 1...24 with 8 bits each, No. 1...8 and one preceding F-bit

Selection of one of the four permissible framing formats is performed by bits FMR4.FM1/0. These formats are:

F4	:	4-frame multiframe
F12	:	12-frame multiframe (D4)
ESF	:	Extended Superframe (F24)
F72	:	72-frame multiframe (SLC96)

The operating mode of the FALC56 is selected by programming the carrier data rate and characteristics, line code, multiframe structure, and signaling scheme.

The FALC56 implements all of the standard and/or common framing structures PCM24 (T1/J1, 1.544 Mbit/s) carriers. The internal HDLC controller supports all signaling procedures including signaling frame synchronization/synthesis in all framing formats.

After reset, the FALC56 must be programmed with FMR1.PMOD = 1 to enable the T1/J1 (PCM24) mode. Switching between the framing formats is done by bit FMR4.FM1/0 for the receiver and for the transmitter.

5.2.2 General Aspects of Synchronization

Synchronization status is reported by bit FRS0.LFA (Loss Of Frame Alignment). Framing errors (pulse frame and multiframe) are counted by the Framing Error Counter FEC.

Asynchronous state is reached if

- 2 out of 4 (bit FMR4.SSC1/0 = 00), or
 - 2 out of 5 (bit FMR4.SSC1/0 = 01), or
 - 2 out of 6 (bit FMR4.SSC1/0 = 10), or
 - 4 consecutive multiframe pattern in ESF format are incorrect (bit FMR4.SSC1/0 = 11).
- If auto mode is enabled, counting of framing errors is interrupted.

The resynchronization procedure is controlled by either one of the following procedures:

- Automatically (FMR4.AUTO = 1). Additionally, it can be triggered by the user by setting/resetting one of the bits FMR0.FRS (force resynchronization) or FMR0.EXLS (external loss of frame).

Functional Description T1/J1

- User controlled, exclusively, by the control bits described above in the non-auto mode (FMR4.AUTO = 0).

5.2.3 Addition for F12 and F72 Format

FT and FS bit conditions, i.e. pulse frame alignment and multiframe alignment can be handled separately if programmed by bit FMR2.SSP. Thus, a multiframe resynchronization can be automatically initiated after detecting 2 errors out of 4/5/6 consecutive multiframing bits without influencing the state of the terminal framing.

In the synchronous state, the setting of FMR0.FRS or FMR0.EXLS resets the synchronizer and initiates a new frame search. The synchronous state is reached if there is only one definite framing candidate. In the case of repeated apparent simulated candidates, the synchronizer remains in the asynchronous state.

In asynchronous state, the function of FMR0.EXLS is the same as above. Setting bit FMR0.FRS induces the synchronizer to lock onto the next available framing candidate if there is one. Otherwise a new frame search is started. This is useful in case the framing pattern that defines the pulseframe position is imitated periodically by a pattern in one of the speech/data channels.

The control bit FMR0.EXLS should be used first because it starts the synchronizer to search for a definite framing candidate.

To observe actions of the synchronizer, the Frame Search Restart Flag FRS0.FSRF is implemented. It toggles at the start of a new frame search if no candidate has been found at previous attempt.

When resynchronization is initiated, the following values apply for the time required to achieve the synchronous state in case there is one definite framing candidate within the data stream:

Table 32 Resynchronization Timing (T1/J1)

Frame Mode	Average	Maximum	Units
F4	1.0	1.5	ms
F12	3.5	4.5	
ESF	3.4	6.125	
F72	13.0	17.75	

Functional Description T1/J1

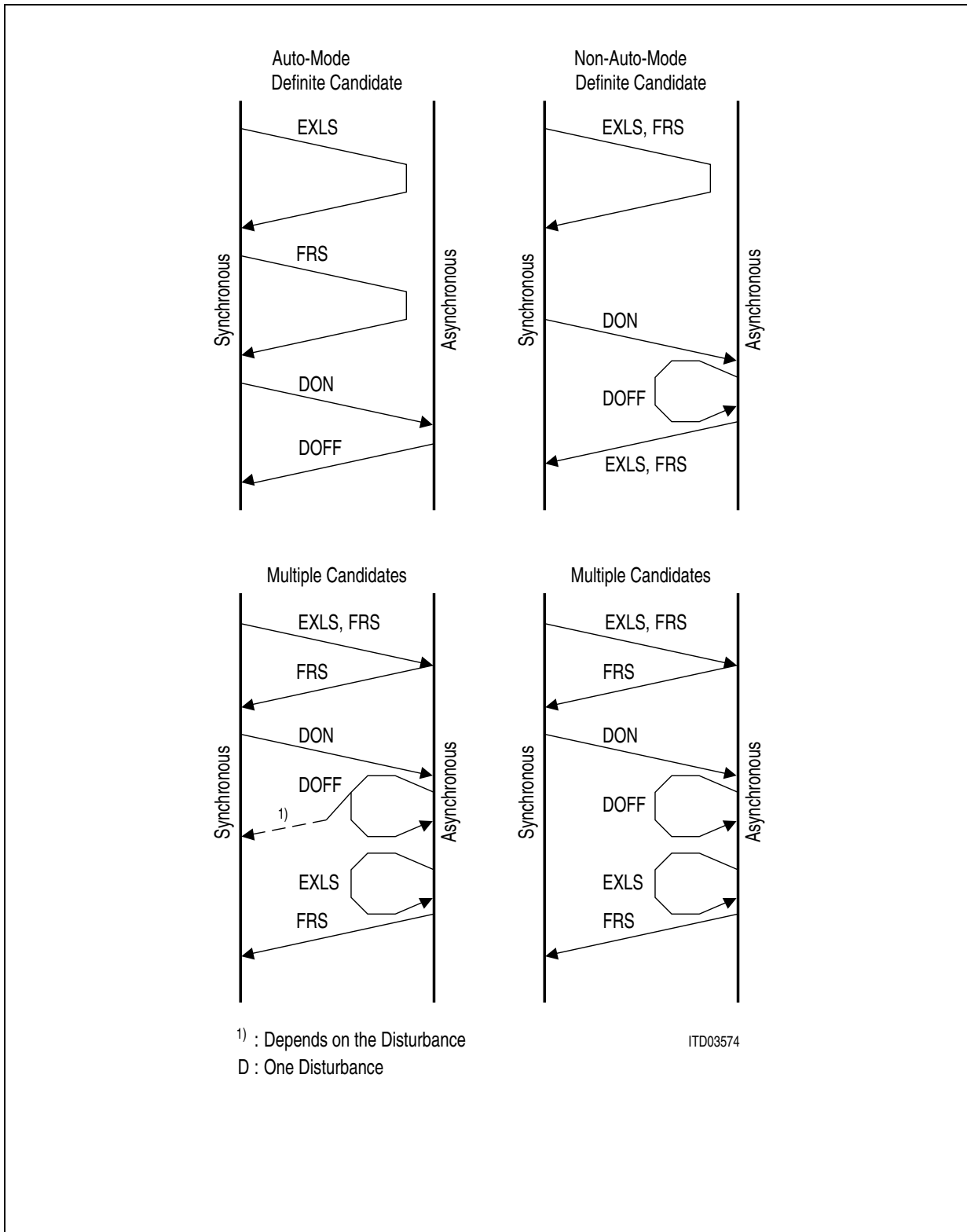

Figure 49 Influences on Synchronization Status (T1/J1)

Functional Description T1/J1

Figure 49 gives an overview of influences on synchronization status for the case of different external actions. Activation of auto mode and non-auto mode is performed by bit FMR4.AUTO. Generally, for initiating resynchronization it is recommended to use bit: FMR0.EXLS first. In cases where the synchronizer remains in the asynchronous state, bit FMR0.FRS is used to enforce it to lock onto the next framing candidate, although it might be a simulated one.

5.2.4 4-Frame Multiframe (F4 Format, T1/J1)

The allocation of the FT-bits (bit 1 of frames 1 and 3) for frame alignment signal is shown in [Table 33](#).

The FS-bit can be used for signaling. Remote alarm (yellow alarm) is indicated by setting bit 2 to 0 in each time slot.

Table 33 4-Frame Multiframe Structure (T1/J1)

Frame Number	F _T	F _S
1	1	
2	–	service bit
3	0	
4	–	service bit

5.2.4.1 Synchronization Procedure

For multiframe synchronization, the terminal framing bits (FT-bits) are observed. The synchronous state is reached if at least one terminal framing candidate is definitely found, or the synchronizer is forced to lock onto the next available candidate (FMR0.FRS).

5.2.5 12-Frame Multiframe (D4 or SF Format, T1/J1)

Normally, this kind of multiframe structure only makes sense when using the CAS robbed-bit signaling. The multiframe alignment signal is located at the FS-bit position of every other frame (refer to [Table 34](#)).

Table 34 12-Frame Multiframe Structure (T1/J1)

Frame Number	F _T	F _S	Signaling Channel Designation
1	1	–	A
2	–	0	
3	0	–	
4	–	0	
5	1	–	
6	–	1	
7	0	–	
8	–	1	
9	1	–	
10	–	1	
11	0	–	B
12	–	0	

There are two possibilities of remote alarm (yellow alarm) indication:

- Bit 2 = 0 in each time slot of a frame, selected with bit FMR0.SRAF = 0
- The last bit of the multiframe alignment signal (bit 1 of frame 12) changes from "0" to "1", selected with bit FMR0.SRAF = 1.

5.2.5.1 Synchronization Procedure

In the synchronous state terminal framing (FT-bits) and multiframe (FS-bits) are observed, independently. Further reaction on framing errors depends on the selected synchronization/resynchronization procedure (by bit FMR2.SSP):

- FMR2.SSP = 0: terminal frame and multiframe synchronization are combined.
Two errors within 4/5/6 framing bits (by bits FMR4.SSC1/0) of one of the above leads to the asynchronous state for terminal framing **and** multiframe. Additionally to the bit FRS0.LFA, loss of multiframe alignment is reported by bit FRS0.LMFA.
The resynchronization procedure starts with synchronizing upon the terminal framing. If the pulse framing has been regained, the search for multiframe alignment is initiated. Multiframe synchronization has been regained after two consecutive correct multiframe patterns have been received.
- FMR2.SSP = 1: terminal frame and multiframe synchronization are separated
Two errors within 4/5/6 terminal framing bits lead to the same reaction as described

Functional Description T1/J1

above for the “combined” mode.

Two errors within 4/5/6 multiframing bits lead to the asynchronous state only for the multiframing. Loss of multiframe alignment is reported by bit FRS0.LMFA. The state of terminal framing is not influenced.

Now, the resynchronization procedure includes only the search for multiframe alignment. Multiframe synchronization has been regained after two consecutive correct multiframe patterns have been received.

5.2.6 Extended Superframe (F24 or ESF Format, T1/J1)

The use of the first bit of each frame for the multiframe alignment word, the data link bits, and the CRC bits is shown in [Table 35](#) on page 144.

Table 35 Extended Superframe Structure (F24, ESF; T1/J1)

Multiframe Frame Number	F-Bits				Signaling Channel Designation
	Multiframe Bit Number	Assignments			
		FAS	DL	CRC	
1	0	–	m	–	A
2	193	–	–	e ₁	
3	386	–	m	–	
4	579	0	–	–	
5	772	–	m	–	
6	965	–	–	e ₂	
7	1158	–	m	–	
8	1351	0	–	–	B
9	1544	–	m	–	
10	1737	–	–	e ₃	
11	1930	–	m	–	
12	2123	1	–	–	
13	2316	–	m	–	
14	2509	–	–	e ₄	
15	2702	–	m	–	C
16	2895	0	–	–	
17	3088	–	m	–	
18	3231	–	–	e ₅	
19	3474	–	m	–	
20	3667	1	–	–	
21	3860	–	m	–	D
22	4053	–	–	e ₆	
23	4246	–	m	–	
24	4439	1	–	–	

5.2.6.1 Synchronization Procedures

For multiframe synchronization the FAS-bits are observed. Synchronous state is reached if at least one framing candidate is definitely found, or the synchronizer is forced to lock onto the next available candidate (FMR0.FRS).

In the synchronous state the framing bits (FAS-bits) are observed. The following conditions selected by FMR4.SSC1/0 lead to the asynchronous state:

- two errors within 4/5/6 framing bits
- two or more erroneous framing bits within one ESF multiframe
- more than 320 CRC6 errors per second interval (FMR5.SSC2)
- 4 incorrect (1 out of 6) consecutive multiframe independent of CRC6 errors.

There are four multiframe synchronization modes selectable using FMR2.MCSP and FMR2.SSP.

- FMR2.MCSP/SSP = 00: In the synchronous state, the setting of FMR0.FRS or FMR0.EXLS resets the synchronizer and initiates a new frame search. The synchronous state is reached again, if there is only one definite framing candidate. In the case of repeated apparent simulated candidates, the synchronizer remains in the asynchronous state.

In asynchronous state, setting bit FMR0.FRS induces the synchronizer to lock onto the next available framing candidate if there is one. At the same time the internal framing pattern memory is cleared and other possible framing candidates are lost.

- FMR2.MCSP/SSP = 01: Synchronization is achieved when 3 consecutive multiframe pattern are correctly found independent of the occurrence of CRC6 errors. If only one or two consecutive multiframe pattern were detected the FALC56 stays in the asynchronous state, searching for a possible additionally available framing pattern. This procedure is repeated until the framer has found three consecutive multiframe pattern in a row.
- FMR2.MCSP/SSP = 10: This mode has been added in order to be able to choose multiple framing pattern candidates step by step. I.e. if in synchronous state the CRC error counter indicates that the synchronization might have been based on an alias framing pattern, setting of FMR0.FRS leads to synchronization on the next candidate available. However, only the previously assumed candidate is discarded in the internal framing pattern memory. The latter procedure can be repeated until the framer has locked on the right pattern (no extensive CRC errors).
The synchronizer is reset completely and initiates a new frame search, if there is no multiframe found. In this case bit FRS0.FSRF toggles.
- FMR2.MCSP/SSP = 11: Synchronization including automatic CRC6 checking
Synchronization is achieved when framing pattern are correctly found and the CRC6 checksum is received without an error. If the CRC6 check failed on the assumed

Functional Description T1/J1

framing pattern the FALC56 stays in the asynchronous state, searching for a possible available framing pattern. This procedure is repeated until the framer has locked on the right pattern. This automatic synchronization mode has been added in order to reduce the microprocessor load.

5.2.6.2 Remote Alarm (yellow alarm) Generation/Detection

Remote alarm (yellow alarm) is indicated by the periodical pattern "1111 1111 0000 0000 ..." in the DL-bits (T1 mode, RC0.SJR = 0). Remote alarm is declared even in the presence of a bit error rate of up to 10^{-3} . The alarm is reset when the yellow alarm pattern no longer is detected.

Depending on bit RC0.SJR = 1 the FALC56 generates and detects the remote alarm according to JT G. 704. In the DL-bit position 16 continuous "1" are transmitted if FMR0.SRAF = 0 and FMR4.XRA = 1.

5.2.6.3 CRC6 Generation and Checking (T1/J1)

Generation and checking of CRC6 bits transmitted/received in the E(6:1) bit positions is done according to ITU-T G.706. The CRC6 checking algorithm is enabled by bit FMR1.CRC. If not enabled, all check bits in the transmit direction are set. In the synchronous state received CRC6 errors are accumulated in a 16 bit error counter and are additionally indicated by an interrupt status.

- CRC6 inversion

If enabled by bit RC0.CRCI, all CRC bits of one outgoing extended multiframe are automatically inverted in case a CRC error is flagged for the previous received multiframe. Setting the bit RC0.XCRCI inverts the CRC bits before transmitted to the distant end. This function is logically ored with RC0.CRCI.

- CRC6 generation/checking according to JT G.706

Setting of RC0.SJR the FALC56 generates and checks the CRC6 bits according to JT G.706. The CRC6 checksum is calculated including the FS/DL-bits. In synchronous state CRC6 errors increment an error counter.

5.2.7 72-Frame Multiframe (SLC96 Format, T1/J1)

The 72-multiframe is an alternate use of the FS-bit pattern and is used for carrying data link information. This is done by stealing some of redundant multiframing bits after the transmission of the 12-bit framing header (refer to [Figure 36](#) on page 148). The position of A and B signaling channels (robbed bit signaling) is defined by zero-to-one and one-to-zero transitions of the FS-bits and is continued when the FS-bits are replaced by the data link bits.

Functional Description T1/J1

Remote alarm (yellow alarm) is indicated by setting bit 2 to zero in each time slot. An additional use of the D-bits for alarm indication is user defined and must be done externally.

5.2.7.1 Synchronization Procedure

In the synchronous state terminal framing (FT-bits) and multiframing (FS-bits of the framing header) are observed independently. Further reaction on framing errors depends on the selected synchronization/resynchronization procedure (by bit FMR2.SSP):

- FMR2.SSP = 0: terminal frame and multiframe synchronization are combined
Two errors within 4/5/6 framing bits (by bits FMR4.SSC1/0) of one of the above lead to the asynchronous state for terminal framing **and** multiframing. Additionally to The resynchronization procedure starts with synchronizing upon the terminal framing. If the pulse framing has been regained, the search for multiframe alignment is initiated. Multiframe synchronization has been regained after two consecutive correct multiframe patterns have been received.
- FMR2.SSP = 1: terminal frame and multiframe synchronization are separated
Two errors within 4/5/6 terminal framing bits lead to the same reaction as described above for the “combined” mode.
Two errors within 4/5/6 multiframing bits lead to the asynchronous state only for the multiframing. Loss of multiframe alignment is reported by bit FRS0.LMFA. The state of terminal framing is not influenced.
Now, the resynchronization procedure includes only the search for multiframe alignment. Multiframe synchronization has been regained after two consecutive correct multiframe patterns have been received.

Functional Description T1/J1

Table 36 72-Frame Multiframe Structure (T1/J1)

Frame Number	F _T	F _S	Signaling Channel Designation
1	1	–	A
2	–	0	
3	0	–	
4	–	0	
5	1	–	
6	–	1	
7	0	–	
8	–	1	
9	1	–	
10	–	1	
11	0	–	
12	–	0	
13	1	–	A
14	–	0	
15	0	–	
16	–	0	
17	1	–	
18	–	1	
19	0	–	
20	–	1	
21	1	–	
22	–	1	
23	0	–	
24	–	D	
25	1	–	A
26	–	D	
27	·	·	
28	·	·	
·	1	–	
66	–	D	
67	0	–	
68	–	D	
69	1	–	
70	–	D	
71	0	–	
72	–	0	
			B

5.2.8 Summary of Frame Conditions (T1/J1)

Table 37 Summary Frame Recover/Out of Frame Conditions (T1/J1)

Format	Frame Recover Condition	Out of Frame Condition
F4	only one FT pattern found, optional forcing on next available FT framing candidate	2 out of 4/5/6 incorrect FT-bits
F12 (D4) and F72 (SLC96)	<p>FMR2.SSP = 0: Combined FT + FS framing search: First searching for FT pattern with optional forcing on next available framing candidates and then for 2 consecutive correct FS pattern¹⁾.</p> <p>FMR2.SSP = 1: Separated FT + FS pattern search: Loss of FT framing starts first search for FT and then for 2 consecutive correct FS pattern¹⁾. Loss of FS framing starts only the FS pattern¹⁾ search.</p>	<p>FMR2.SSP = 0: 2 out of 4/5/6 incorrect FT- or FS-bits</p> <p>FMR2.SSP = 1: 2 out of 4/5/6 incorrect FT-bits searched in FT and FS framing bits, 2 out of 4/5/6 incorrect FS-bits searched only the FS framing.</p>
F24 (ESF)	<p>FMR2.MCSP/SSP = 00: only one FAS pattern found, optional forcing on next available FAS framing candidate with discarding of all remaining framing candidates.</p> <p>FMR2.MCSP/SSP = 01: 3 consecutive correct multiframing found independent of CRC6 errors.</p> <p>FMR2.MCSP/SSP = 10: choosing multiple framing pattern step by step, optional forcing on next available FAS framing pattern with discarding only of the previous assumed framing candidate.</p> <p>FMR2.MCSP/SSP = 11: FAS framing correctly found and CRC6 check error free.</p>	<p>2 out of 4/5 incorrect FAS-bits or 2 out of 6 incorrect FAS-bits per multiframe or 4 consecutive incorrect multiframing pattern or more than 320 CRC6 errors per second interval</p>

¹⁾ In F12 (D4) format bit 1 in frame 12 is excluded from the synchronization process.

5.3 Additional Receive Framer Functions (T1/J1)

5.3.1 Error Performance Monitoring and Alarm Handling

- Alarm Indication Signal: Detection and recovery is flagged by bit FRS0.AIS and ISR2.AIS. Transmission is enabled by bit FMR1.XAIS.
- Loss-Of-Signal: Detection and recovery is flagged by bit FRS0.LOS and ISR2.LOS.
- Remote Alarm Indication: Detection and release is flagged by bit FRS0.RRA and ISR2.RA/RAR. Transmission is enabled by bit FMR4.XRA.
- Excessive Zeros: Detection is flagged by bit FRS1.EXZD.
- Pulse-Density Violation: Detection is flagged by bit FRS1.PDEN and ISR0.PDEN.
- Transmit Line Shorted: Detection and release is flagged by bit FRS1.XLS and ISR1.XLSC.
- Transmit Ones-Density: Detection and release is flagged by bit FRS1.XLO and ISR1.XLSC.

Table 38 Summary of Alarm Detection and Release (T1/J1)

Alarm	Detection Condition	Clear Condition
Red Alarm or Loss-Of-Signal (LOS)	no transitions (logical zeros) in a programmable time interval of 16 to 4096 consecutive pulse periods. Programmable receive input signal threshold	programmable number of ones (1 to 256) in a programmable time interval of 16 to 4096 consecutive pulse periods. A one is a signal with a level above the programmed threshold. or the pulse-density is fulfilled and no more than 15 contiguous zeros during the recovery interval are detected.
Blue Alarm or Alarm Indication Signal (AIS)	FMR4.AIS3 = 0: less than 3 zeros in 12 frames or 24 frames (ESF), FMR4.AIS3 = 1: less than 4 zeros in 12 frames or less than 6 zeros in 24 frames (ESF)	active for at least one multiframe. FMR4.AIS3 = 0: more than 2 zeros in 12 or 24 frames (ESF), FMR4.AIS3 = 1: more than 3 zeros in 12 frames or more than 5 zeros in 24 frames (ESF)

Functional Description T1/J1

Table 38 Summary of Alarm Detection and Release (T1/J1) (cont'd)

Alarm	Detection Condition	Clear Condition
Yellow Alarm or Remote Alarm (RRA) ¹⁾	RC1.RRAM = 0: bit 2 = 0 in 255 consecutive time slots or FS-bit = 1 of frame12 in F12 (D4) format or 8×1,8×0 in the DL channel (ESF) RC1.RRAM = 1: bit 2 = 0 in every time slot per frame or FS-bit = 1 of frame12 in F12 (D4) format or 8×1,8×0 in the DL channel (ESF)	RC1.RRAM = 0: set conditions no longer detected. RC1.RRAM = 1: bit 2 = 0 not detected in 3 consecutive frames or FS-bit not detected in 3 consecutive multiframe or 8×1,8×0 not detected for 3 times in a row (ESF).
Excessive Zeros (EXZD)	more than 7 (BZS code) or more than 15 (AMI code) contiguous zeros	Latched Status: cleared on read
Pulse-Density Violation (PDEN)	less than N ones in each and every time window of 8×(N+1) time slots with N taking all values of 1 to 23 or more than 15 consecutive zeros	Latched Status: cleared on read
Transmit Line Short (XLS)	more than 3 pulse periods with highly increased transmit line current on XL1/2	transmit line current limiter inactive
Transmit Ones-Density (XLO)	32 consecutive zeros in the transmit data stream on XL1/2	Cleared with each transmitted pulse

¹⁾ RRA detection operates in the presence of 10⁻³ bit error rate.

5.3.2 Auto Modes

- Automatic remote alarm (Yellow Alarm) access
If the receiver has lost its synchronization (FRS0.LFA) a remote alarm (yellow alarm) is sent to the distant end automatically, if enabled by bit FMR2.AXRA. In synchronous state the remote alarm bit is removed.
- Automatic AIS to system interface
In asynchronous state the synchronizer enforces an AIS to the receive system interface automatically. However, received data is switched through transparently if bit FMR2.DAIS is set.

Functional Description T1/J1

- Automatic clock source switching
In slave mode (LIM0.MAS = 0) the DCO-R synchronizes on the recovered route clock. In case of loss-of-signal (LOS) the DCO-R switches to master mode automatically. If bit CMR1.DCS is set, automatic switching from RCLK to SYNC is disabled.
- Automatic freeze signaling:
Updating of the received signaling information is controlled by the freeze signaling status. The freeze signaling status is activated automatically, if a loss-of-signal or a loss of multiframe alignment or a receive slip occurs. The internal signaling buffer RS(12:1) is frozen. Optionally automatic freeze signaling is disabled by setting bit SIC3.DAF = 1.

5.3.3 Error Counter

The FALC56 offers six error counters where each of them has a length of 16 bit. They record code violations, framing bit errors, CRC6 bit errors, errored blocks and the number of received multiframes in asynchronous state or the changes of frame alignment (COFA). Counting of the multiframes in asynchronous state and of the COFA parameter is done in a 6/2-bit counter. Each of the error counters is buffered. Buffer update is done in two modes:

- One-second accumulation
- On demand using handshake with writing to the DEC register.

In the one-second mode an internal/external one-second timer updates these buffers and resets the counter to accumulate the error events in the next one-second period. The error counter cannot overflow. Error events occurring during error counter reset are not be lost.

5.3.4 Errored Second

The FALC56 supports the error performance monitoring by detecting the following alarms or error events in the received data:

framing errors, CRC errors, code violations, loss of frame alignment, loss-of-signal, alarm indication signal, receive and transmit slips.

With a programmable interrupt mask register ESM all these alarms or error events can generate an Errored Second Interrupt (ISR3.ES) if enabled.

5.3.5 One-Second Timer

Additionally a one-second timer interrupt can be generated internally to indicate that the enabled alarm status bits or the error counters have to be checked. The one-second timer signal is output on port SEC/FSC (GPC1.CSFP1/0). Optionally synchronization to an external second timer is possible which has to be provided on pin SEC/FSC. Selecting the external second timer is done with GCR.SES. Refer also to register GPC1 for input/output selection.

5.3.6 Clear Channel Capability

For support of common T1 applications, clear channels can be specified through the 3-byte register bank CCB(1:3). In this mode the contents of selected transmit time slots are not overwritten by internally or externally sourced bit-robbing and zero code suppression (B7 stuffing) information.

5.3.7 In-Band Loop Generation and Detection

The FALC56 generates and detects a framed or unframed in-band loop-up (activate, 00001) and loop-down (deactivate, 001) pattern according to ANSI T1.403 with bit error rates as high as 10^{-2} . Framed or unframed in-band loop code is selected by LCR1.FLLB. Replacing the in-band loop codes with transmit data is done by FMR5.XLD/XLU.

The FALC56 also offers the ability generating and detecting of a flexible in-band loop-up and -down pattern (LCR1.LLBP = 1). The loop-up and loop-down pattern is individually programmable from 2 to 8 bits in length (LCR1.LAC1/0 and LCR1.LDC1/0). Programming of loop codes is done in registers LCR2 and LCR3.

Status and interrupt status bits inform the user whether loop-up or loop-down code was detected.

5.3.8 Transparent Mode

The transparent modes are useful for loop-backs or for routing data unchanged through the FALC56.

In receive direction, transparency for ternary or dual-/single-rail unipolar data is always achieved if the receiver is in the synchronous state. All bits in F-bit position of the incoming multiframe are forwarded to RDO and inserted in the FS/DL time slot or in the F-bit position. In asynchronous state the received data is switched through transparently if bit FMR2.DAIS is set. Setting of bit LOOP.RTM disconnects control of the elastic buffer from the receiver. The elastic buffer is now in a "free running" mode without any possibility to update the time slot assignment to a new frame position in case of resynchronization of the receiver. Together with FMR2.DAIS this function is used to realize undisturbed transparent reception.

Setting bit FMR4.TM switches the FALC56 in transmit transparent mode:

In transmit direction bit 8 of the FS/DL time slot from the system highway (XDI) is inserted in the F-bit position of the outgoing frame. For complete transparency the internal signaling controller, idle code generation, AIS alarm generation, single channel and payload loop-back has to be disabled and cleared channels have to be defined by registers CCB1...3.

5.3.9 Pulse-Density Detection

The FALC56 examines the receive data stream on the pulse-density requirement which is defined by ANSI T1. 403. More than 14 consecutive zeros or less than N ones in each

Functional Description T1/J1

and every time window of $8 \times (N+1)$ data bits where $N = 23$ are detected. Violations of these rules are indicated by setting the status bit FRS1.PDEN and the interrupt status bit ISR0.PDEN. Generation of the interrupt status is programmed either with the detection or with any change of state of the pulse-density alarm (GCR.SCI).

5.4 Transmit Path in T1/J1 Mode

5.4.1 Transmitter (T1/J1)

The serial bit stream is then processed by the transmitter which has the following functions:

- Frame/multiframe synthesis of one of the four selectable framing formats
- Insertion of service and data link information
- AIS generation (blue alarm)
- Remote alarm (yellow alarm) generation
- CRC generation and insertion of CRC bits
- CRC bits inversion in case of a previously received CRC error or in case of activating per control bit
- Generation of loop-up/-down code
- Idle code generation per DS0

The frame/multiframe boundaries of the transmitter can be synchronized externally by using the $\overline{\text{SYPX/XMFS}}$ pin. Any change of the transmit time slot assignment subsequently produces a change of the framing bit positions on the line side. This feature is required if signaling and data link bits are routed through the switching network and are inserted in transmit direction by the system interface.

In loop-timed configuration (LIM2.ELT) disconnecting the control of the transmit system highway from the transmitter is done by setting FMR5.XTM. The transmitter is now in a free running mode without any possibility to update the multiframe position in case of changing the transmit time slot assignment. The FS/DL-bits are generated independent of the transmit system interface. For proper operation the transmit elastic buffer size should be programmed to 2 frames.

The contents of selectable time slots is overwritten by the pattern defined by register IDLE. The selection of "idle channels" is done by programming the three-byte registers ICB(3:1).

If AMI coding with zero code suppression (B7-stuffing) is selected, "clear channels" without B7-stuffing can be defined by programming registers CCB(3:1).

5.4.2 Transmit Line Interface (T1/J1)

The analog transmitter transforms the unipolar bit stream to ternary (alternate bipolar) return to zero signals of the appropriate programmable shape. The unipolar data is provided on pin XDI and the digital transmitter.

Functional Description T1/J1

Similar to the receive line interface three different data types are supported:

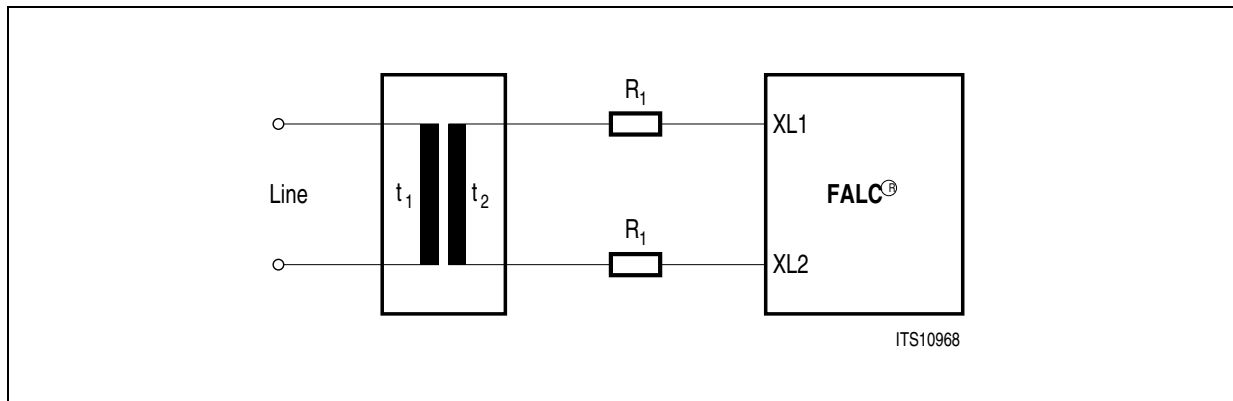

Figure 50 Transmitter Configuration (T1/J1)

Table 39 Recommended Transmitter Configuration Values (T1/J1)

Parameter	T1	J1
Characteristic Impedance [Ω]	100	110
R_1 ($\pm 1\%$) [Ω]	2 ¹⁾	
t2 : t1	1 : 2.4	

¹⁾ This value refers to an ideal transformer without any parasitics. Any transformer resistance or other parasitic resistances have to be taken into account when calculating the final value of the output serial resistors.

- Ternary Signal
Single-rail data is converted into a ternary signal which is output on pins XL1 and XL2. Selection between B8ZS or simple AMI coding with zero code suppression (B7 stuffing) is provided. B7 stuffing can be disabled on a per time slot basis (Clear Channel capability). Selected by FMR0.XC1/0 and LIM1.DRS = 0.
- Dual-rail data PCM(+), PCM(-) at multifunction ports XDOP and XDON with 50% or 100% duty cycle and with programmable polarity. Line coding is done in the same way as in ternary interface mode. Selected by FMR0.XC1 = 1 and LIM1.DRS = 1.
- Unipolar data on port XOID is transmitted in NRZ (non return to zero) with 100% duty cycle or in CMI code with or without (SIC3.CMI) preprocessed by B8ZS coding to a fiber-optical interface. Clocking off data is done with the rising edge of the transmit clock XCLK (1544 kHz) and with a programmable polarity. Selection is done by FMR0.XC1 = 0 and LIM1.DRS = 1.

5.4.3 Transmit Jitter Attenuator (T1/J1)

The transmit jitter attenuator DCO-X circuitry generates a "jitter-free" transmit clock and meets the following requirements: PUB 62411, PUB 43802, TR-TSY 009, TR-TSY 253, TR-TSY 499 and ITU-T I.431 and G.703. The DCO-X circuitry works internally with the

Functional Description T1/J1

same high frequency clock as the receive jitter attenuator. It synchronizes either to the working clock of the transmit backplane interface or the clock provided on pin TCLK or the receive clock RCLK (remote loop/loop-timed). The DCO-X attenuates the incoming jitter starting at 6 Hz with 20 dB per decade fall-off. With the jitter attenuated clock, which is directly depending on the phase difference of the incoming clock and the jitter attenuated clock, data is read from the transmit elastic buffer (2 frames) or from the JATT buffer (2 frames, remote loop). Wander with a jitter frequency below 6 Hz is passed transparently.

The DCO-X accepts gapped clocks which are used in ATM or SDH/SONET applications. The jitter attenuated clock is output on pin XCLK or optionally on pin CLK2.

In case of missing clock on pin SCLKX the DCO-X centers automatically, if selected by bit $CMR2.DCOXC = 1$.

The transmit jitter attenuator can be disabled. In that case data is read from the transmit elastic buffer with the clock sourced on pin TCLK (1.544 or 6.176 MHz). Synchronization between SCLKX and TCLK has to be done externally.

In the loop-timed clock configuration (LIM2.ELT) the DCO-X circuitry generates a transmit clock which is frequency synchronized on RCLK. In this configuration the transmit elastic buffer has to be enabled.

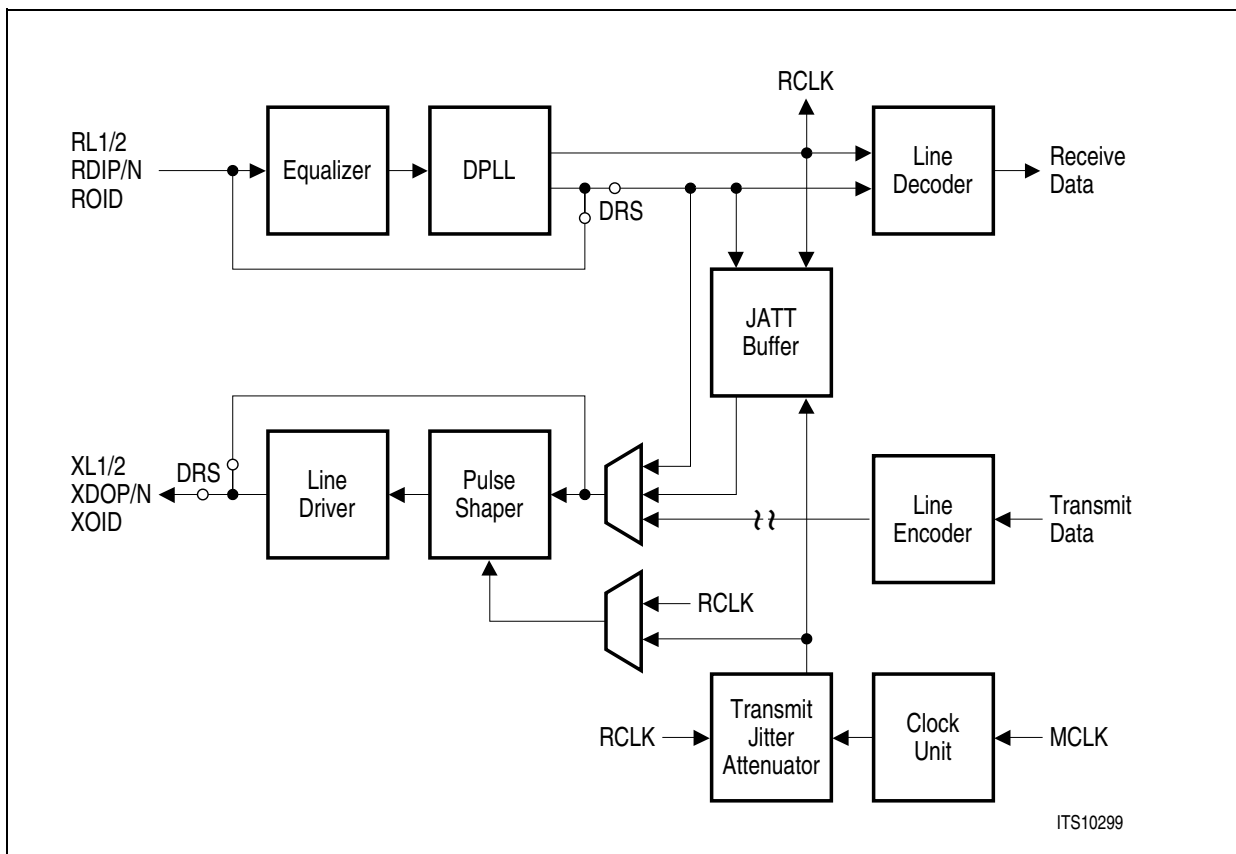

Figure 51 Clocking in Remote Loop Configuration (T1/J1)

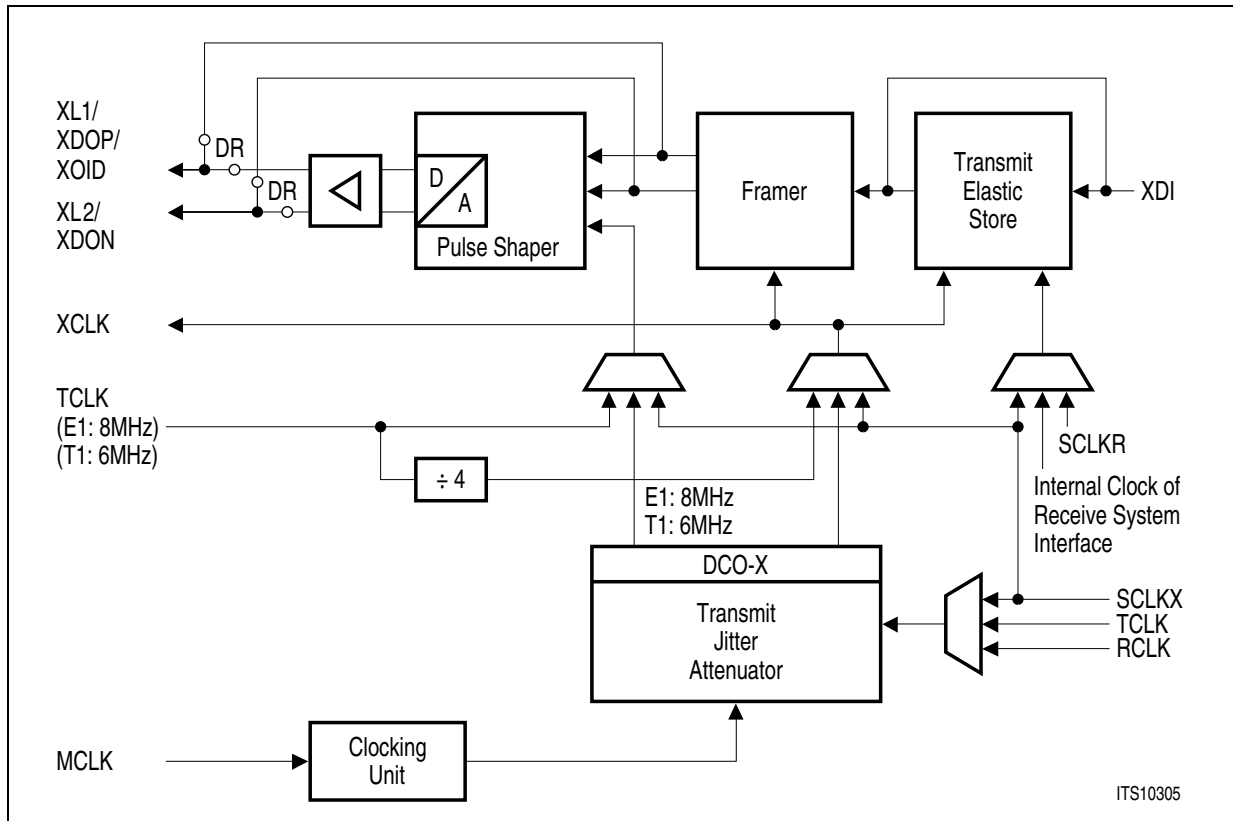

Figure 52 Transmit Clock System (T1/J1)

Note: DR = Dual-Rail interface

DCO-X Digital Controlled Oscillator transmit

5.4.4 Transmit Elastic Buffer (T1/J1)

The transmit elastic store with a size of max. 2×193 bit (two frames) serves as a temporary store for the PCM data to adapt the system clock (SCLKX) to the internally generated clock for the transmit data, and to retranslate time slot structure used in the system to that of the line side. Its optimal start position is initiated when programming the transmit time slot offset values. A difference in the effective data rates of system side and transmit side lead to an overflow or underflow of the transmit memory. Thus, errors in data transmission to the remote end occur. This error condition (transmit slip) is reported to the microprocessor by interrupt status registers.

The received bit stream from pin XDI is optionally stored in the transmit elastic buffer. The memory is organized as the receive elastic buffer. Programming of the transmit buffer size is done by SIC1.XBS1/0:

- XBS1/0 = 00: bypass of the transmit elastic buffer
- XBS1/0 = 01: one frame buffer or 193 bits
Maximum of wander amplitude (peak-to-peak): (1 UI = 648 ns)
System interface clocking rate: modulo 2.048 MHz:

Functional Description T1/J1

- Maximum of wander: 70 UI in channel translation mode 0
- Maximum of wander: 45 UI in channel translation mode 1
- System interface clocking rate: modulo 1.544 MHz:
- Maximum of wander: 74 UI
- average delay after performing a slip: 96 bits
- XBS1/0 = 10: two frame buffer or 386 bits
- System interface clocking rate: modulo 2.048 MHz:
- 142 UI in channel translation mode 0
- 78 UI in channel translation mode 1
- System interface clocking rate: modulo 1.544 MHz:
- Maximum of wander: 140 UI
- average delay after performing a slip: 193 bits
- XBS1/0 = 11: short buffer or 96 bits:
- System interface clocking rate: modulo 2.048 MHz:
- Maximum of wander: 28 UI in channel translation mode 0; channel translation mode 1 not supported
- System interface clocking rate: modulo 1.544 MHz:
- Maximum of wander: 38 UI
- average delay after performing a slip: 48 bits

The functions of the transmit buffer are:

- Clock adaption between system clock (SCLKX/R) and internally generated transmit route clock (XCLK) or externally sourced TCLK.
- Compensation of input wander and jitter.
- Frame alignment between system frame and transmit route frame
- Reporting and controlling of slips

Writing of received data from XDI is controlled by SCLKX/R and $\overline{\text{SYPX}}/\text{XMFS}$ in combination with the programmed offset values for the transmit time slot/clock slot counters. Reading of stored data is controlled by the clock generated by DCO-X circuitry or the externally generated TCLK and the transmit framer. With the de-jittered clock data is read from the transmit elastic buffer and are forwarded to the transmitter. Reporting and controlling of slips is automatically done according to the receive direction. Positive/negative slips are reported in interrupt status bits ISR4.XSP and ISR4.XSN.

A reinitialization of the transmit memory is done by reprogramming the transmit time slot counter XC1 and with the next $\overline{\text{SYPX}}$ pulse. After that, this memory has its optimal start position.

The frequency of the working clock for the transmit system interface is programmable by SIC1.SSC1/0 and SIC2.SSC2 in a range of 1.544 to 12.352 MHz/2.048 to 16.384 MHz. Generally the data or marker on the system interface are clocked off or latched on the rising or falling edge (SIC3.RESX) of the SCLKX clock. Some clocking rates allow transmission of time slots/marker in different channel phases. Each channel phase

Functional Description T1/J1

which shall be latched on ports XDI and XP(A:D) is programmable by bits SIC2.SICS(2:0), the remaining channel phases are cleared or ignored respectively.

The following table gives an overview of the transmit buffer operating modes.

Table 40 Transmit Buffer Operating Modes (T1/J1)

Buffer Size	TS Offset programming	Slip performance
bypass	enabled	no
short buffer	disabled	yes
1 frame	enabled	yes
2 frames	enabled	yes

5.4.5 Programmable Pulse Shaper and Line Build-Out (T1/J1)

In long-haul applications the transmit pulse masks are optionally generated according to FCC68 and ANSI T1. 403. To reduce the crosstalk on the received signals the FALC56 offers the ability to place a transmit attenuator in the data path. Transmit attenuation is selectable from 0, -7.5, -15 or -22.5 dB (register LIM2.LBO2/1). ANSI T1. 403 defines only 0 to -15 dB.

The FALC56 includes a programmable pulse shaper to satisfy the requirements of ANSI T1. 102, also various DS1, DSX-1 specifications are met. The amplitude of the pulse shaper is individually programmable by the microprocessor to allow a maximum of different pulse templates. The line length is selected by programming the registers XPM(2:0) as shown for typical values in the table below. The values are optimized for transformer ratio: 1:2.4; cable: PULP 22AWG (100 Ω); serial resistors: 2 Ω.

Table 41 Pulse Shaper Programming (T1/J1)

Range in m	Range in ft.	XPM0	XPM1	XPM2	XP04-XP00	XP14-XP10	XP24-XP20	XP34-XP30
		hexadecimal			decimal			
0 to 40	0 to 133	D7	22	1	23	22	8	2
40 to 81	133 to 266	FA	26	1	26	23	9	2
81 to 122	266 to 399	3D	37	1	29	25	13	2
122 to 162	399 to 533	5F	3F	1	31	26	15	2
162 to 200	533 to 655	3F	CB	1	31	25	18	3

The transmitter requires an external step up transformer to drive the line.

5.4.6 Transmit Line Monitor (T1/J1)

The transmit line monitor compares the transmit line current on XL1 and XL2 with an on-chip transmit line current limiter. The monitor detects faults on the primary side of the transformer indicated by a highly increased transmit line current (more than 120 mA for at least 3 consecutive pulses sourced by V_{DDX} ¹⁾) and protects the device from damage by setting the transmit line driver XL1/2 into high-impedance state automatically (if enabled by XPM2.DAXLT = 0). The current limiter checks the actual current value of XL1/2 and if the transmit line current drops below the detection limit the high-impedance state is cleared.

Two conditions are detected by the monitor: transmit line de-jitteredity (more than 31 consecutive zeros) indicated by FRS1.XLO and transmit line high current indicated by FRS1.XLS. In both cases a transmit line monitor status change interrupt is provided.

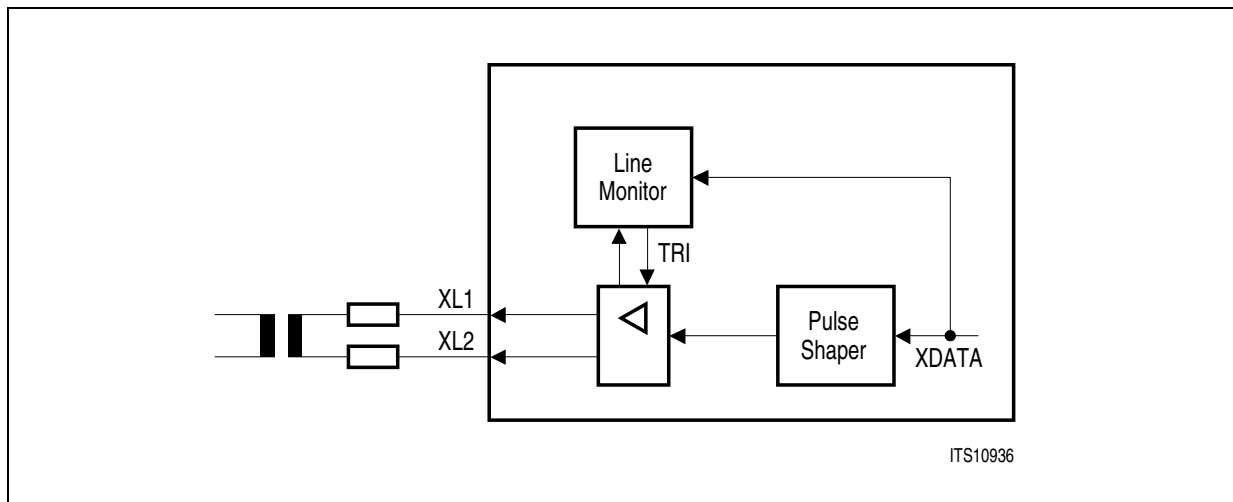

Figure 53 Transmit Line Monitor Configuration (T1/J1)

5.4.7 Transmit Signaling Controller (T1/J1)

Similar to the receive signaling controller the same signaling methods and the same time slot assignment are provided. The FALC56 performs the following signaling and data link methods.

5.4.7.1 HDLC or LAPD access

The transmit signaling controller of the FALC56 performs the flag generation, CRC generation, zero bit stuffing and programmable idle code generation. Buffering of transmit data is done in the 64 byte deep XFIFO. The signaling information is internally multiplexed with the data applied to port XDI or XSIG.

In signaling controller transparent mode, fully transparent data transmission without

¹⁾ shorts between XL1 or XL2 and V_{DDX} are not detected

Functional Description T1/J1

HDLC framing is performed. Optionally the FALC56 supports the continuous transmission of the XFIFO contents.

Operating in HDLC or BOM mode “flags” or “idle” are transmitted as interframe timefill. The FALC56 offers the flexibility to insert data during certain time slots. Any combinations of time slots can be programmed separately for the receive and transmit direction if using HDLC channel 1. HDLC channel 2 and 3 support one programmable time slot common for receive and transmit direction each.

5.4.7.2 Support of Signaling System #7

The HDLC controller of channel 1 supports the signaling system #7 (SS7) which is described in ITU-Q.703. The following description assumes, that the reader is familiar with the SS7 protocol definition.

SS7 support must be activated by setting the MODE register. Data stored in the transmit FIFO (XFIFO) is sent automatically. The SS7 protocol is supported by the following hardware features in transmit direction:

- transmission of flags at the beginning of each Signaling Unit
- bit stuffing (zero insertion)
- calculation of the CRC16 checksum:

The transmitter adds the checksum to each Signaling Unit.

Each signaling unit written to the transmit FIFO (XFIFO, 2×32 bytes) is sent once or repeatedly including flags, CRC checksum and stuffed bits. After e.g. an MSU has been transmitted completely, the FALC56 optionally starts sending of FISUs containing the forward sequence number (FSN) and the backward sequence number (BSN) of the previously transmitted signaling unit. Setting bit CCR5.AFX causes Fill In Signaling Units (FISUs) to be sent continuously, if no HDLC or Signaling Unit (SU) is to be transmitted from XFIFO. During update of XFIFO, automatic transmission is interrupted and resumed after update is completed. The internally generated FISUs contain FSN and BSN of the last transmitted signaling unit written to XFIFO.

Using $CMDR.XREP = 1$, the contents of XFIFO can be sent continuously. Clearing of $CMDR.XRES/SRES$ stops the automatic repetition of transmission. This function is also available for HDLC frames, so no flag generation, CRC byte generation and bit stuffing is necessary.

Example: After an MSU has been sent repetitively and XREP has been cleared, FISUs are sent automatically.

5.4.7.3 CAS Bit-Robbing (T1/J1, serial mode)

The signaling controller inserts the bit stream either on the transmit line side or if external signaling is enabled on the transmit system side. Signaling data is sourced on port XSIG, which is selected by register $PC(4:1)$ and $FMR5.EIBR = 1$.

Functional Description T1/J1

In external signaling mode the signaling data is sampled with the working clock of the transmit system interface (SCLKX) together with the transmit synchronous pulse (SYPX). Data on XSIG is latched in the bit positions 5 to 8 per time slot, bits 1 to 4 are ignored. The FS/DL-bit is sampled on port XSIG and inserted in the outgoing data stream. The received CAS multiframe is inserted frame aligned into the data stream on XDI. Data sourced by the internal signaling controller overwrites the external signaling data which must be valid during the last frame of a multiframe.

Internal multiplexing of data and signaling data can be disabled on a per time slot basis (clear channel capability). This is also valid when using the internal and external signaling mode.

5.4.7.4 CAS Bit-Robbing (T1/J1, μ P access mode)

The signaling controller inserts the bit stream either on the transmit line side or if external signaling is enabled on the transmit system side. Signaling data is sourced internally from registers XS(12:1).

Internal multiplexing of data and signaling data can be disabled on a per time slot basis (clear channel capability). This is also valid when using the internal and external signaling mode.

5.4.7.5 Data Link Access in ESF/F24 and F72 Format (T1/J1)

The DL-channel protocol is supported as follows:

- access is done on a multiframe basis through registers XDL(3:1) or
- HDLC access or transparent transmission (non HDLC mode) from XFIFO (HDLC channel 1 only)

The signaling information stored in the XFIFO is inserted in the DL-bits of frame 26 to 72 in F72 format or in every other frame in ESF format. Transmission can be done on a multiframe boundary (CCR1.XMFA = 1). Operating in HDLC or BOM mode “flags” or “idle” are transmitted as interframe timefill.

5.4.7.6 Periodical Performance Report in ESF Format (T1/J1)

According to ANSI T1.403 the FALC56 can automatically generate the **Periodical Performance Report (PPR)** and transmit it every second in the data link channel of the extended superframe format (ESF/F24 only). Automatic sending of this report can be enabled/disabled by the use of bit CCR5.EPR. A single report can be initiated manually at any time (by setting CMDR2.XPPR = 1).

Performance information is sampled every second and the report contains data of the last four seconds as shown in the following tables.

Functional Description T1/J1

Table 42 Structure of Periodical Performance Report (T1/J1)¹⁾

Octet No.	8	7	6	5	4	3	2	1	time
1	FLAG = 01111110								
2	SAPI = 001110					CR ²⁾	EA=0		
3	TEI = 0000000						EA=1		
4	CONTROL = 00000011 = unacknowledged frame								
5	G3	LV	G4	U1	U2	G5	SL	G6	t_0
6	FE	SE	LB	G1	R	G2	Nm	N1	
7	G3	LV	G4	U1	U2	G5	SL	G6	t_0-1 s
8	FE	SE	LB	G1	R	G2	Nm	N1	
9	G3	LV	G4	U1	U2	G5	SL	G6	t_0-2 s
10	FE	SE	LB	G1	R	G2	Nm	N1	
11	G3	LV	G4	U1	U2	G5	SL	G6	t_0-3 s
12	FE	SE	LB	G1	R	G2	Nm	N1	
13	FCS								
14	FCS								
15	FLAG = 01111110								

¹⁾ The rightmost bit (bit 1) is transmitted first for all fields except for the two bytes of the FCS that are transmitted leftmost bit (bit 8) first.

²⁾ reflects state of bit CCR5.CR

Functional Description T1/J1

Table 43 Bit Functions in Periodical Performance Report¹⁾

Bit Value	Interpretation
G1 = 1	number of CRC error events = 1
G2 = 1	1 < number of CRC error events ≤ 5
G3 = 1	5 < number of CRC error events ≤ 10
G4 = 1	10 < number of CRC error events ≤ 100
G5 = 1	100 < number of CRC error events ≤ 319
G6 = 1	number of CRC error events ≥ 320
SE = 1	Severely errored framing event ≥ 1 (FE shall be 0)
FE = 1	Frame synchronization bit error event ≥ 1 (SE shall be 0)
LV = 1	Line code violation event ≥ 1
SL = 1	Slip event ≥ 1
LB = 1	Payload loop-back activated
U1	not used (default value = 0)
U2	not used (default value = 0)
R	not used (default value = 0)
NmNi	One-second report modulo 4 counter

¹⁾ according to ANSI T1.403

5.5 System Interface in T1/J1 Mode

The FALC56 offers a flexible feature for system designers where for transmit and receive direction different system clocks and system pulses are necessary. The interface to the receive system highway is realized by two data buses, one for the data RDO and one for the signaling data RSIG. The receive highway is clocked on pin SCLKR, while the interface to the transmit system highway is independently clocked on pin SCLKX. The frequency of these working clocks and the data rate of 2.048/4.096/8.192/16.384/1.544/3.088/6.192/12.352 Mbit/s for the receive and transmit system interface is programmable by SIC1.SSC1/0, SIC2.SSC2 and SIC1.SSD1, FMR1.SSD0. Selectable system clock and data rates and their valid combinations are shown in the table below.

Table 44 System Clocking and Data Rates (T1/J1)

System Data Rate	Clock Rate 1.544/2.048 MHz	Clock Rate 3.088/4.096 MHz	Clock Rate 6.176/8.192 MHz	Clock Rate 12.352/ 16.384 MHz
1.544/2.048 Mbit/s	x	x	x	x
3.088/4.096 Mbit/s	--	x	x	x
6.176/8.192 Mbit/s	--	--	x	x
12.352/16.384 Mbit/s	--	--	--	x

x = valid, -- = invalid

Generally the data or marker on the system interface are clocked off or latched on the rising or falling edge (SIC3.RESR/X) of the SCLKR/X clock. Some clocking rates allow transmission of time slots in different channel phases. Each channel phase which shall be active on ports RDO, XDI, RP(A:D) and XP(A:D) is programmable by bit SIC2.SICS(2:0), the remaining channel phases are cleared or ignored.

The signals on pin $\overline{\text{SYPR}}$ in combination with the assigned time slot offset in register RC0 and RC1 define the beginning of a frame on the receive system highway. The signal on pin $\overline{\text{SYPX}}$ or XMFS together with the assigned time slot offset in register XC0 and XC1 define the beginning of a frame on the transmit system highway.

Adjusting the frame begin (time slot 0, bit 0) relative to $\overline{\text{SYPR/X}}$ or XMFS is possible in the range of 0 to 125 μs . The minimum shift of varying the time slot 0 begin can be programmed between 1 bit and 1/8 bit depending of the system clocking and data rate, e.g. with a clocking/data rate of 2.048 MHz shifting is done bit by bit, while running the FALC56 with 16.384 MHz and 2.048 Mbit/s data rate it is done by 1/8 bit.

A receive frame marker RFM can be activated during any bit position of the entire frame. Programming is done with registers RC1/0. The pin function RFM is selected by PC(4:1).RPC(2:0) = 001. The RFM selection disables the internal time slot assigner, no offset programming is performed. The receive frame marker is active high for one 1.544/

Functional Description T1/J1

2.048 MHz cycle and is clocked off with the rising or falling edge of the clock which is in/output on port SCLKR (see SIC3.RESX/R).

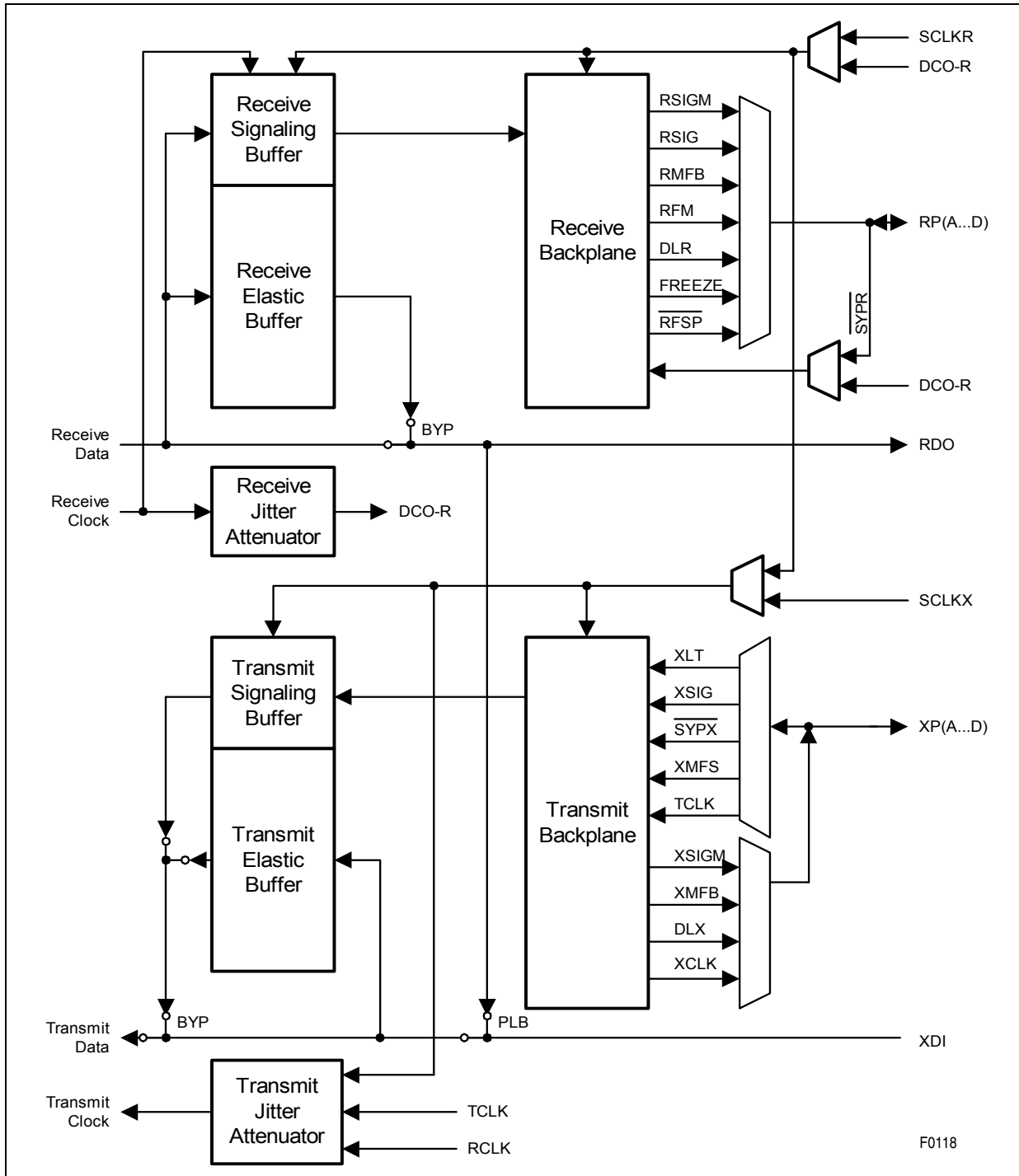

Figure 54 System Interface (T1/J1)

5.5.1 Receive System Interface (T1/J1)

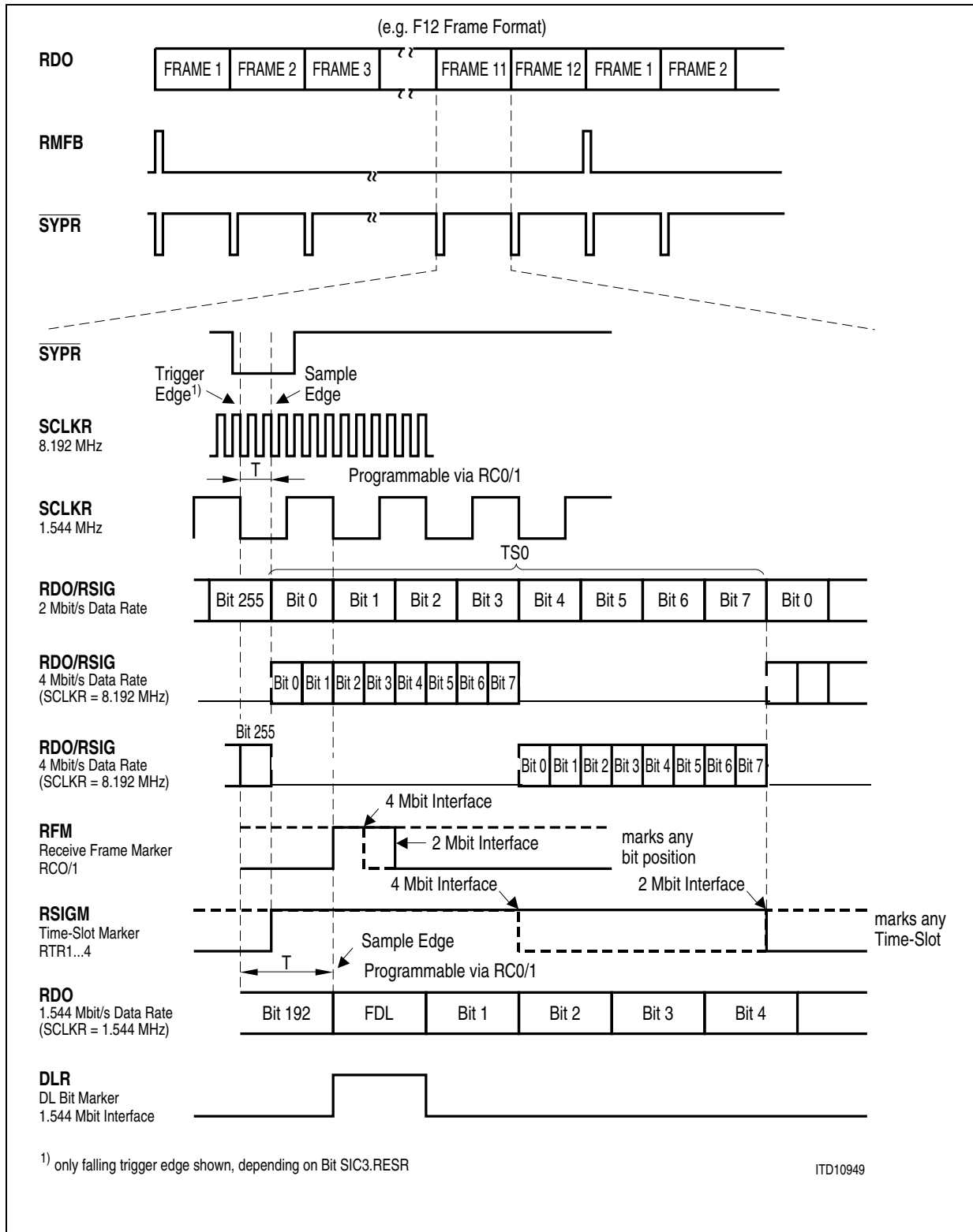

Figure 55 Receive System Interface Clocking (T1/J1)

5.5.1.1 Receive Offset Programming

Depending on the selection of the synchronization signals ($\overline{\text{SYPR}}$ or RFM), different calculation formulas are used to define the position of the synchronization pulses. These formulas are given below, see [Figure 56](#) to [Figure 59](#) for explanation. The pulse length of $\overline{\text{SYPR}}$ and RFM is always the basic T1/J1 bit width (648 ns) in 1.544-MHz mode or the E1 bit width (488 ns) in 2.048-MHz mode.

This chapter describes the system highway operation in 1.544-MHz mode only. If the system highway is operated in 2.048-MHz mode, the description given in [Chapter 4.5.1.1](#) on [page 106](#) applies.

$\overline{\text{SYPR}}$ Offset Calculation

- T: Time between beginning of $\overline{\text{SYPR}}$ pulse and beginning of next frame (time slot 0, bit 0), measured in number of SCLKR clock intervals
maximum delay: $T_{\max} = (193 \times \text{SC}/\text{SD}) - 1$
- SD: Basic data rate; 1.544 Mbit/s
- SC: System clock rate; 1.544, 3.088, 6.176, or 12.352 MHz
- X: Programming value to be written to registers RC0 and RC1 (see [page 359](#)).

$$0 \leq T \leq 4: \quad X = 4 - T + (7 \times \text{SC}/\text{SD})$$

$$5 \leq T \leq T_{\max}: \quad X = (200 \times \text{SC}/\text{SD}) + 4 - T$$

RFM Offset Calculation

- MP: Marker position of RFM, counting in SCLKR clock cycles (0 = F-bit)
- SC = 1.544 MHz: $0 \leq \text{MP} \leq 192$
- SC = 3.088 MHz: $0 \leq \text{MP} \leq 385$
- SC = 6.176 MHz: $0 \leq \text{MP} \leq 771$
- SC = 12.352 MHz: $0 \leq \text{MP} \leq 1543$
- SD: Basic data rate; 1.544 Mbit/s
- SC: System clock rate; 1.544, 3.088, 6.176, or 12.352 MHz
- X: Programming value to be written to registers RC0 and RC1 (see [page 359](#)).

$$0 \leq \text{MP} \leq 193 \times (\text{SC}/\text{SD}) - 3: \quad X = \text{MP} + 2 + (7 \times \text{SC}/\text{SD})$$

$$193 \times (\text{SC}/\text{SD}) - 2 \leq \text{MP} \leq 193 \times (\text{SC}/\text{SD}) - 1: \quad X = \text{MP} + 2 - (186 \times \text{SC}/\text{SD})$$

Functional Description T1/J1

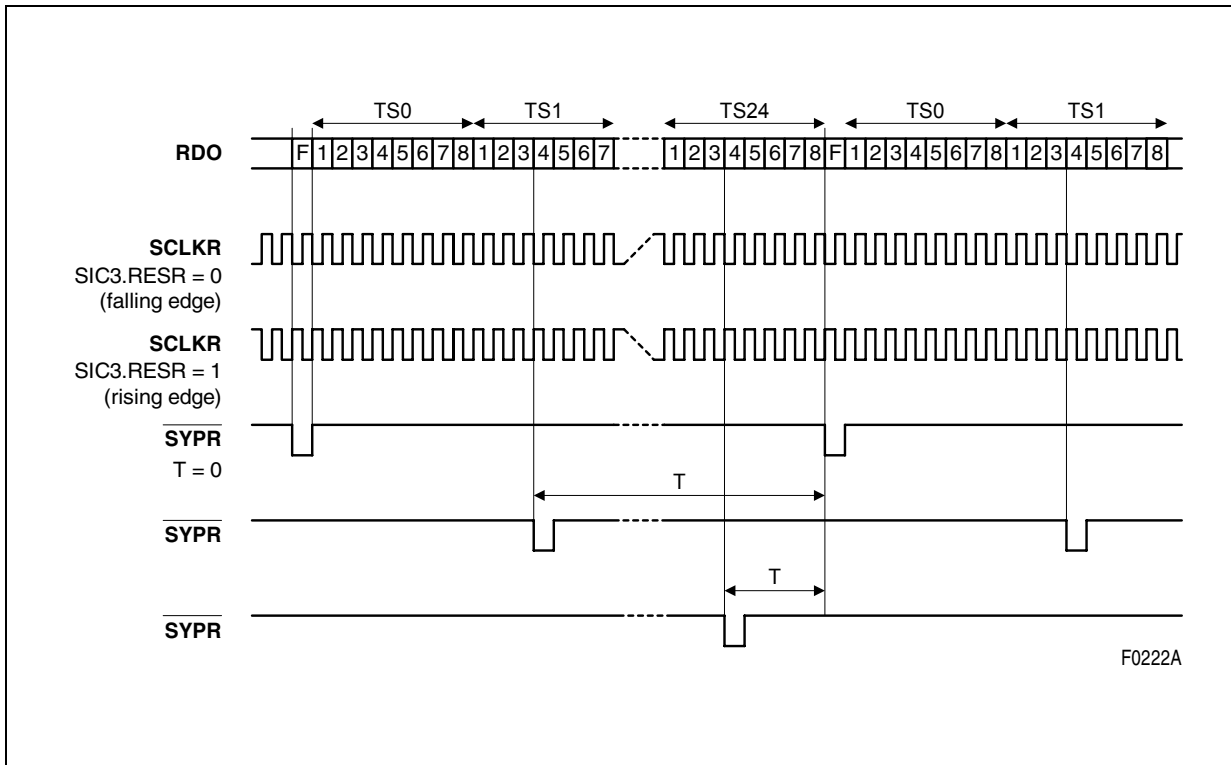

Figure 56 SYPR Offset Programming (1.544 Mbit/s, 1.544 MHz)

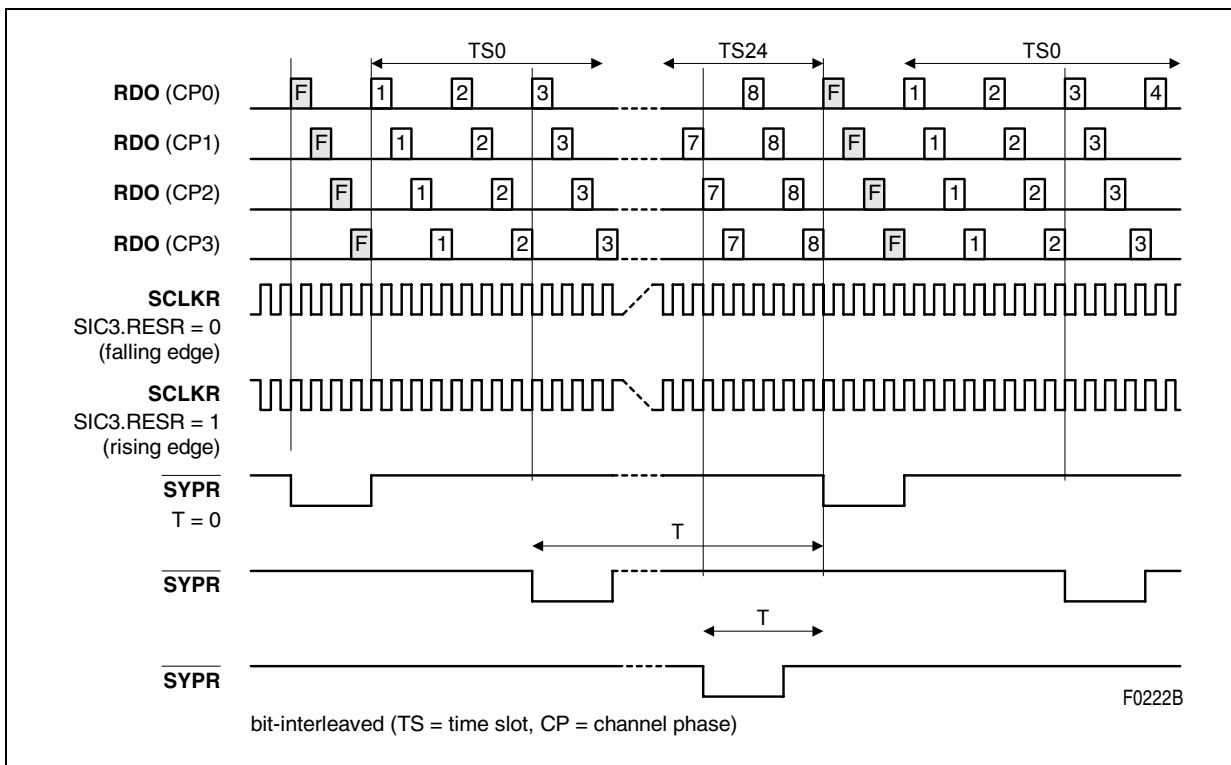

Figure 57 SYPR Offset Programming (6.176 Mbit/s, 6.176 MHz)

Functional Description T1/J1

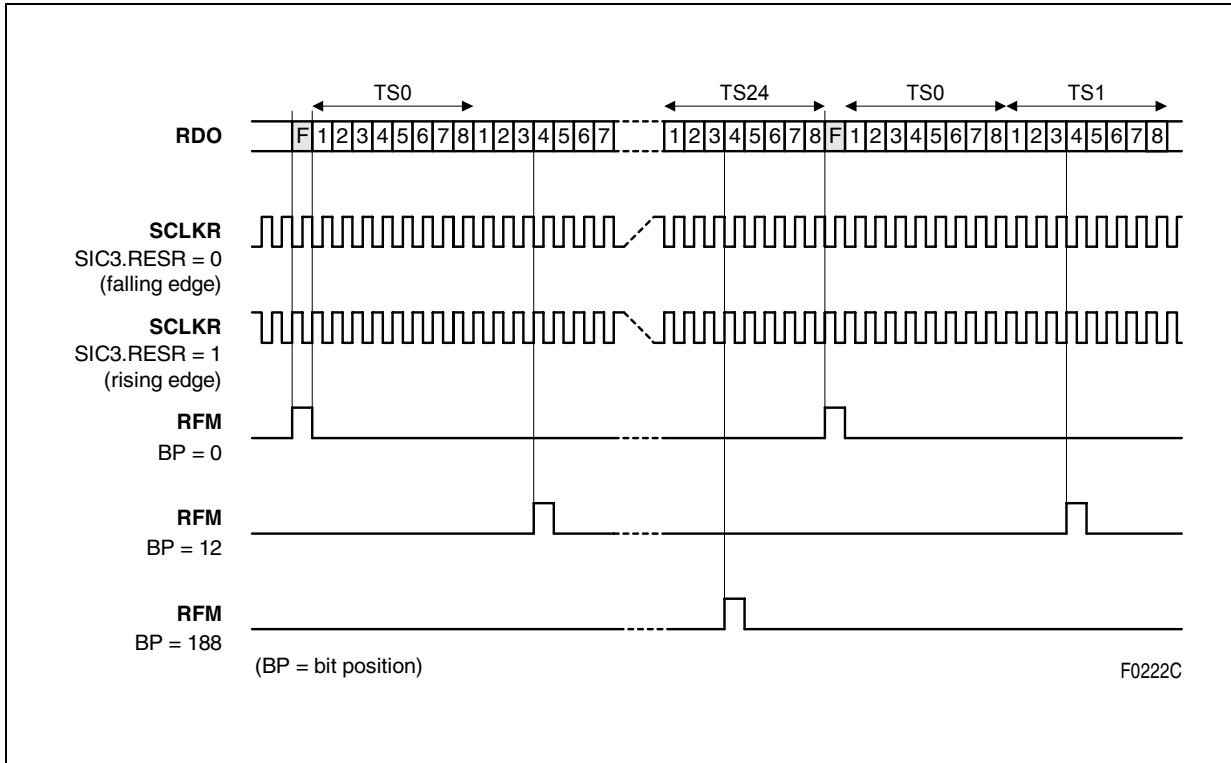

Figure 58 RFM Offset Programming (1.544 Mbit/s, 1.544 MHz)

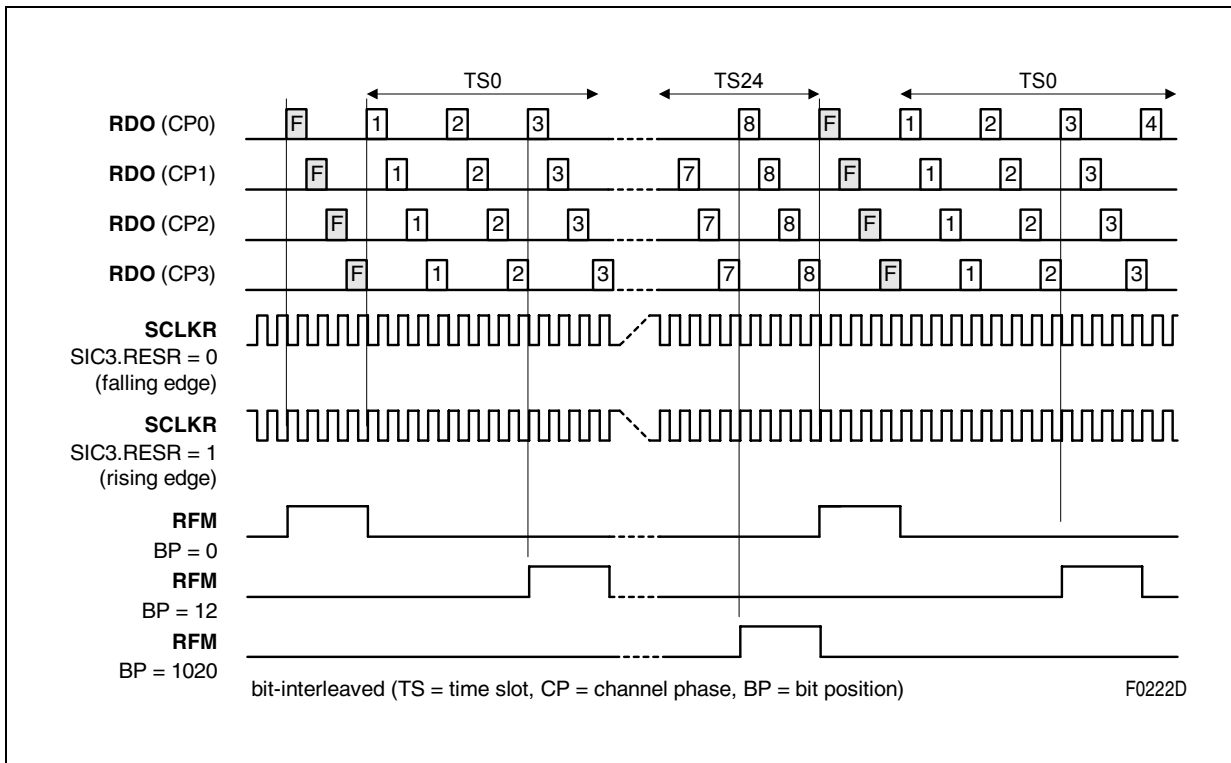

Figure 59 RFM Offset Programming (6.176 Mbit/s, 6.176 MHz)

Functional Description T1/J1

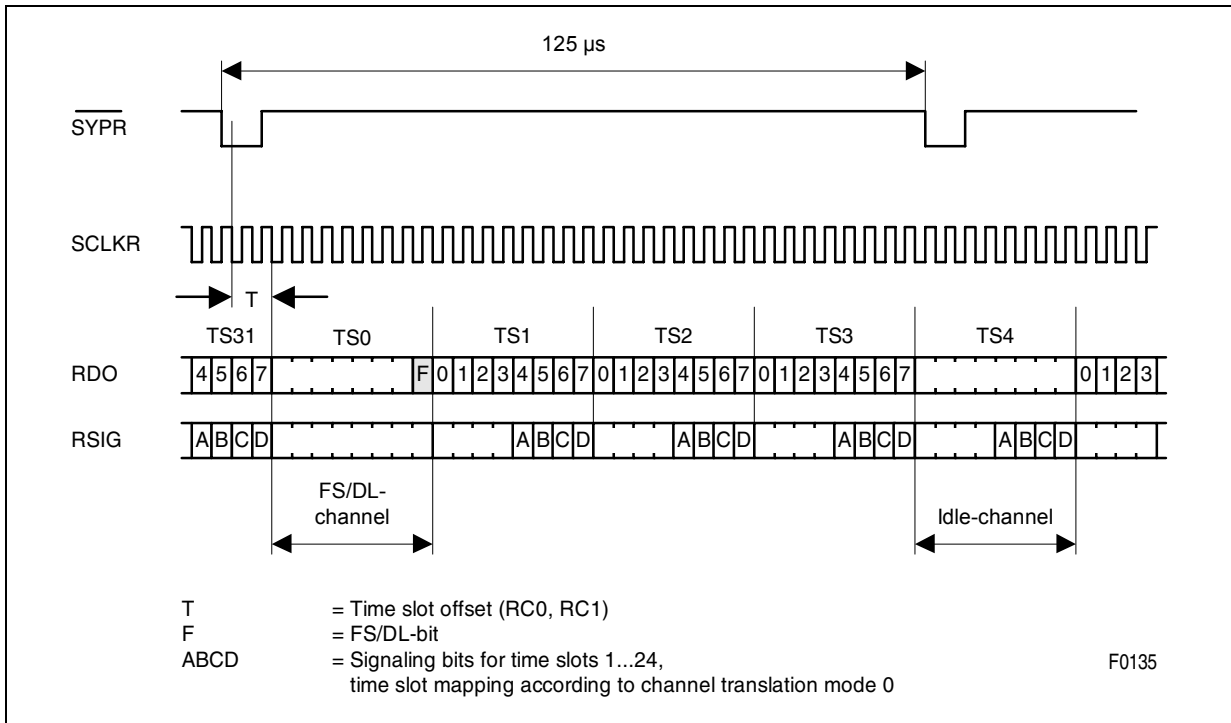

Figure 60 2.048 MHz Receive Signaling Highway (T1/J1)

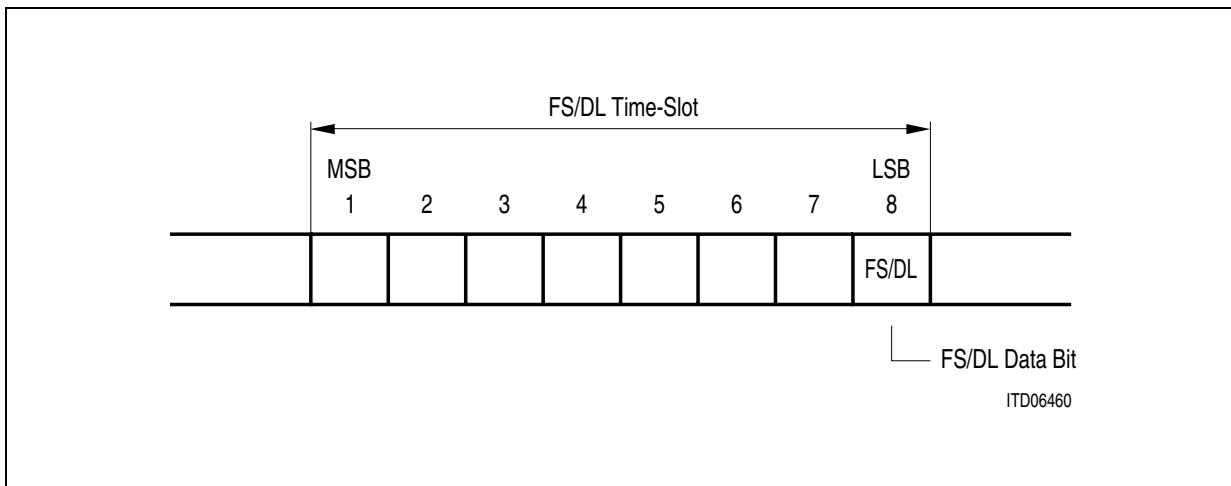

Figure 61 Receive FS/DL-Bits in Time Slot 0 on RDO (T1/J1)

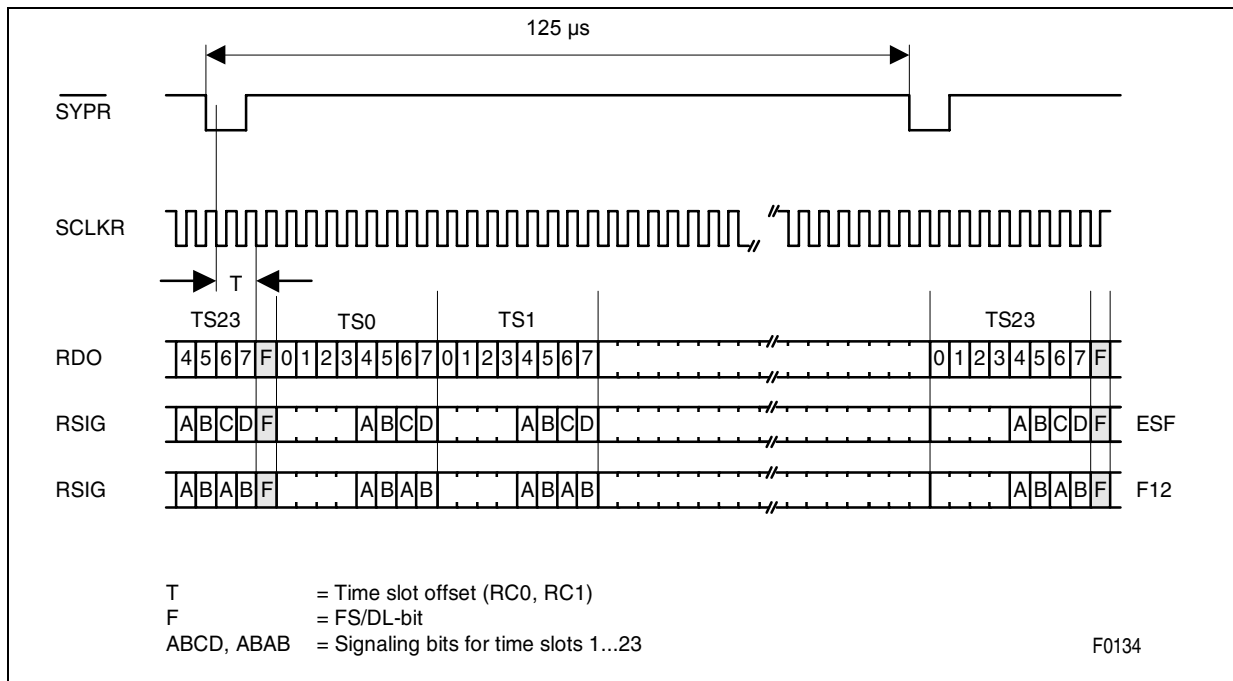

Figure 62 1.544 MHz Receive Signaling Highway (T1/J1)

5.5.2 Transmit System Interface (T1/J1)

Compared to the receive paths the inverse functions are performed for the transmit direction.

The interface to the transmit system highway is realized by two data buses, one for the data XDI and one for the signaling data XSIG. The time slot assignment is equivalent to the receive direction. All unequipped (idle) time slots are ignored.

Latching of data is controlled by the system clock (SCLKX or SCLKR) and the synchronization pulse ($\overline{\text{SYPX}}$ /XMFS) in combination with the programmed offset values for the transmit time slot/clock slot counters XC1/0. The frequency of the working clock 2.048/4.096/8.192/16.384 MHz or 1.544/3.088/6.176/12.352 MHz for the transmit system interface is programmable by SIC1.SSC1/0 and SIC2.SSC2. Refer also [Table 44](#).

The received bit stream on ports XDI and XSIG can be multiplexed internally on a time slot basis, if enabled by SIC3.TTRF = 1. The data received on port XSIG can be sampled if the transmit signaling marker XSIGM is active high. Data on port XDI is sampled if XSIGM is low for the corresponding time slot. Programming the XSIGM marker is done with registers TTR(4:1).

Note: XSIG is required in the last frame of a multiframe only and ignored in all other frames.

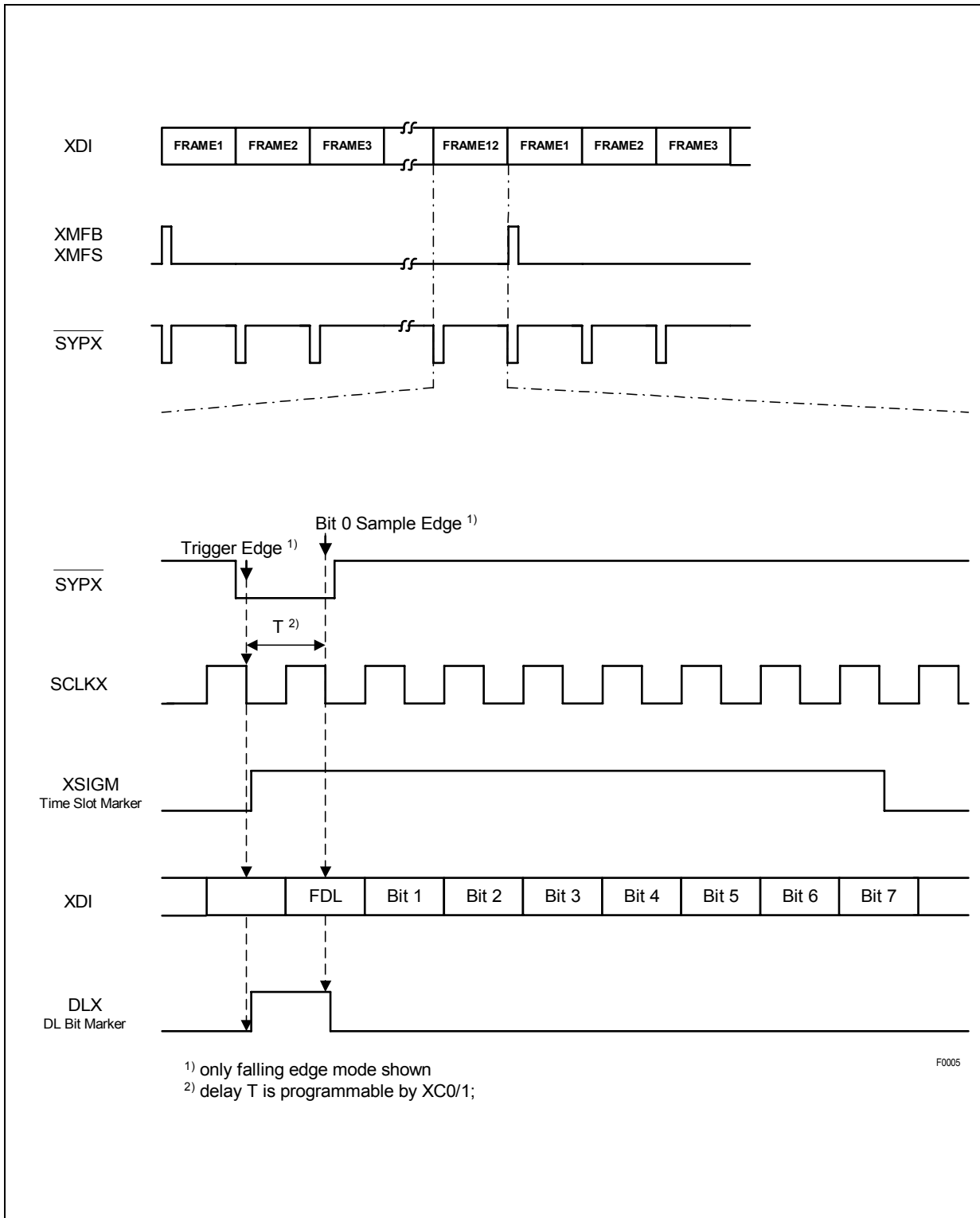

Figure 63 Transmit System Clocking: 1.544 MHz (T1/J1)

Functional Description T1/J1

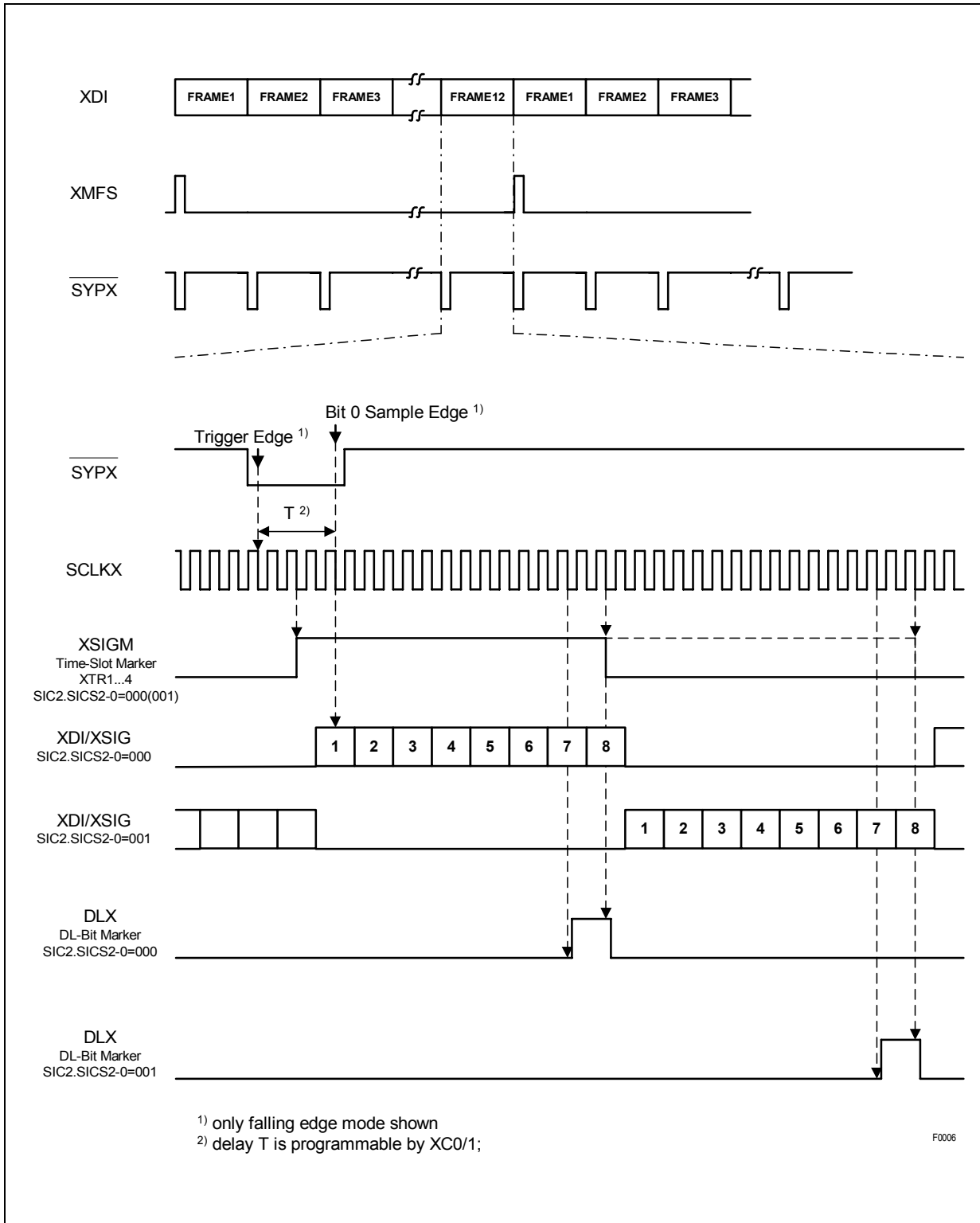

Figure 64 Transmit System Clocking: 8.192 MHz/4.096 Mbit/s (T1/J1)

Functional Description T1/J1

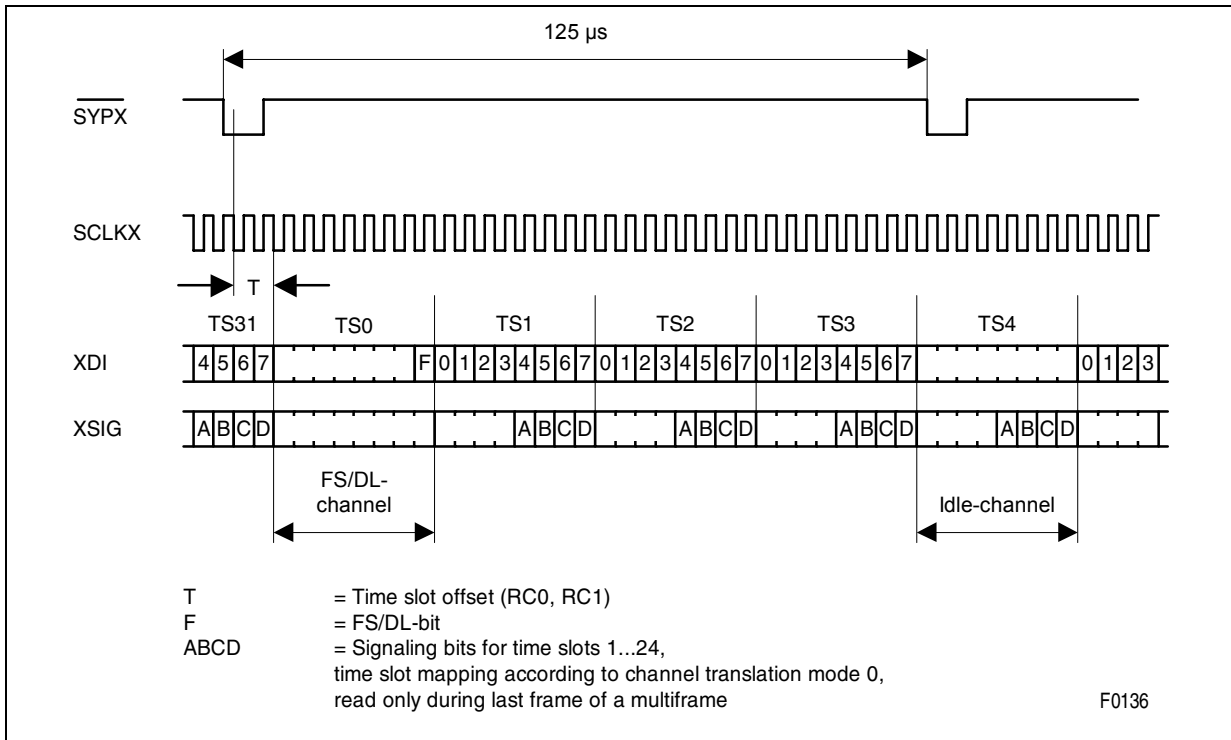

Figure 65 2.048 MHz Transmit Signaling Clcking (T1/J1)

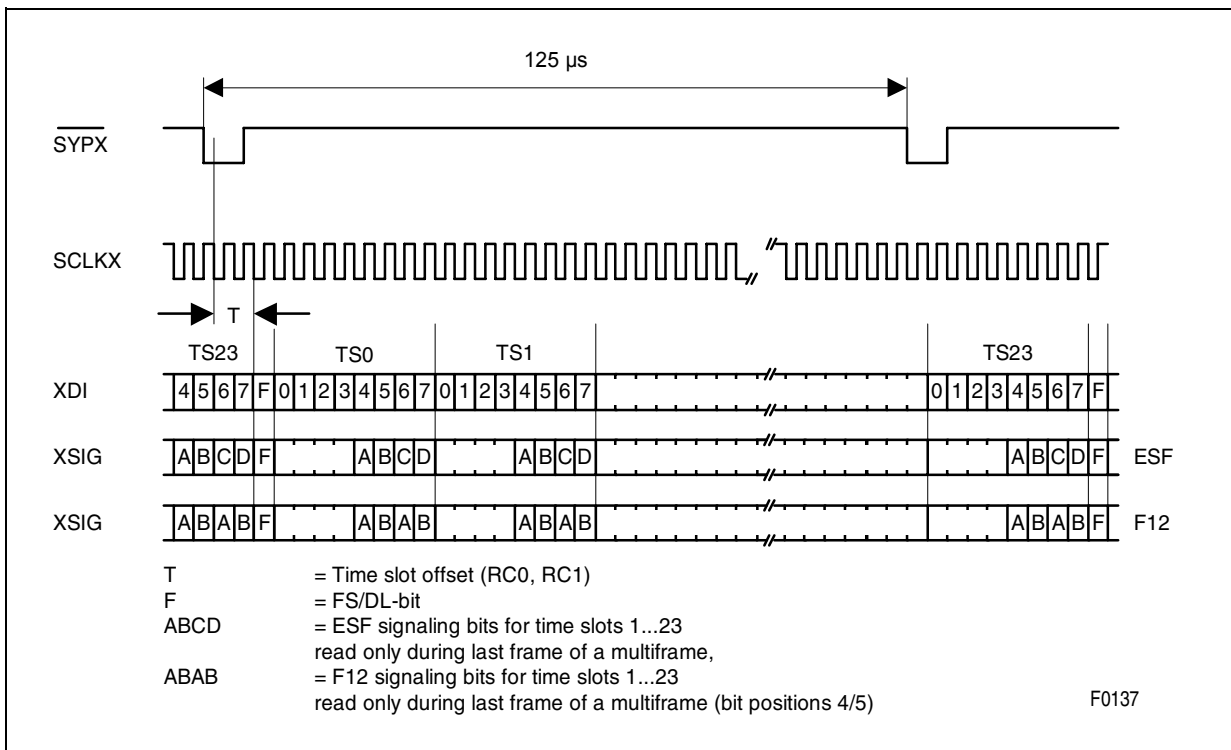

Figure 66 1.544 MHz Transmit Signaling Highway (T1/J1)

Functional Description T1/J1

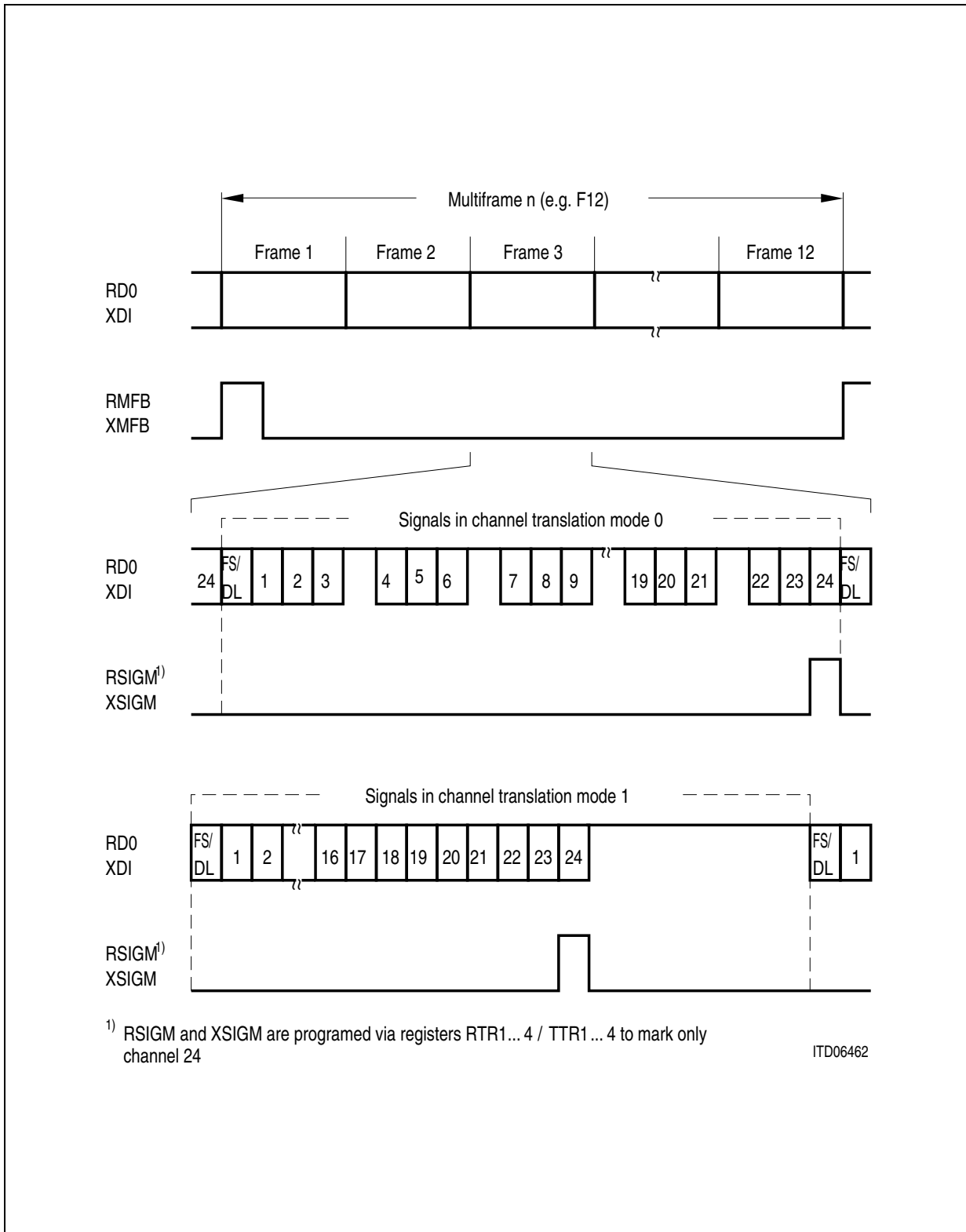

Figure 67 Signaling Marker for CAS/CAS-CC Applications (T1/J1)

Functional Description T1/J1

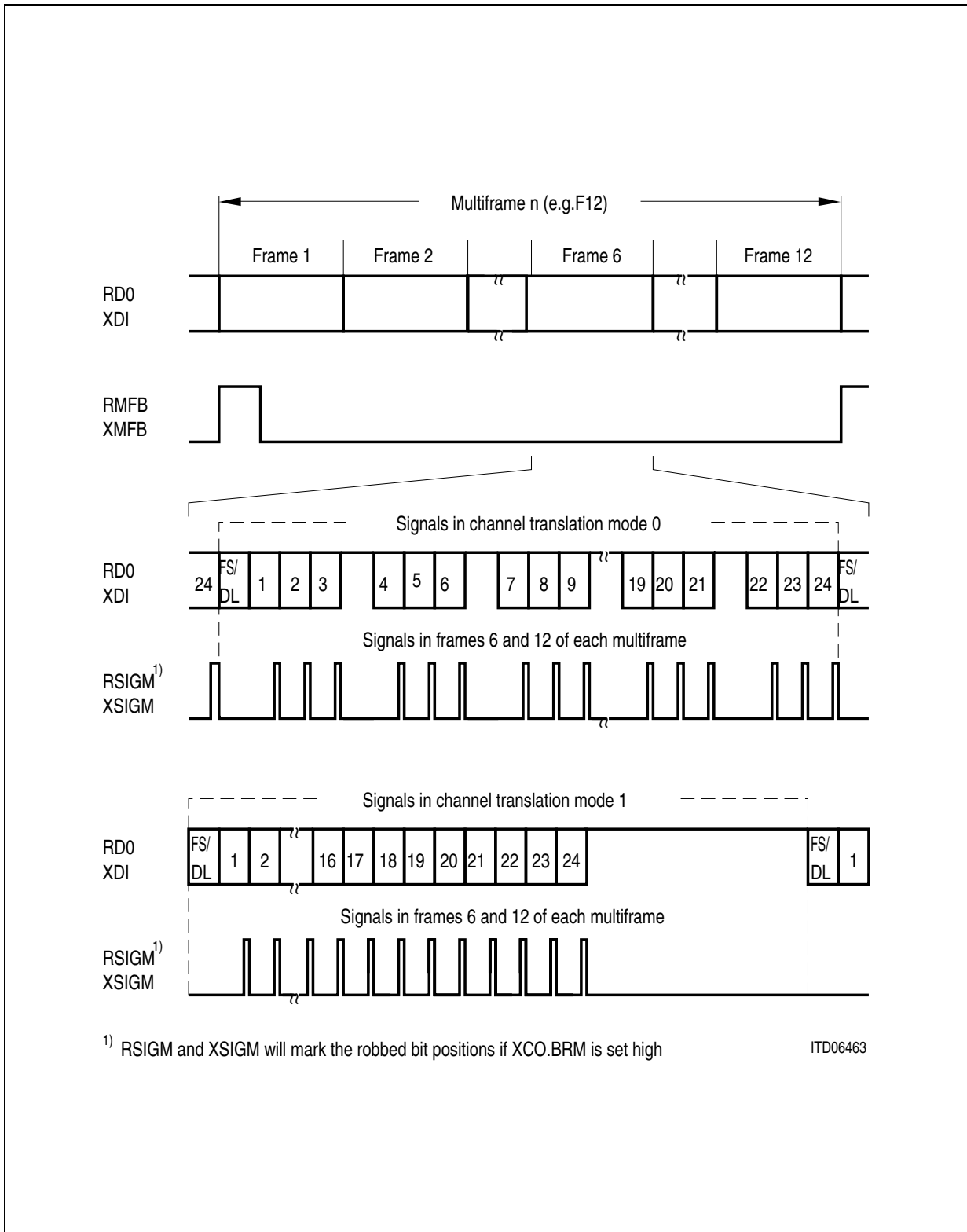

Figure 68 Signaling Marker for CAS-BR Applications (T1/J1)

FS/DL data on system transmit highway (XDI), time slot 0:

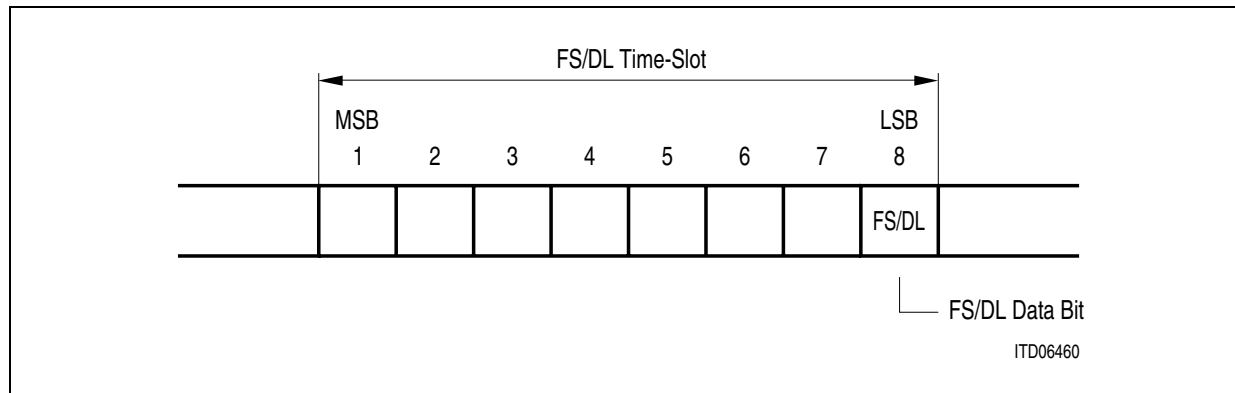

Figure 69 Transmit FS/DL Bits on XDI (T1/J1)

5.5.2.1 Transmit Offset Programming

The pulse length of $\overline{\text{SYPX}}$ and RFM is always the basic T1/J1 bit width (648 ns) in 1.544-MHz mode or the E1 bit width (488 ns) in 2.048-MHz mode.

This chapter describes the system highway operation in 1.544-MHz mode only. If the system highway is operated in 2.048-MHz mode, the description given in [Chapter 4.5.2.1](#) on [page 111](#) applies.

$\overline{\text{SYPX}}$ Offset Calculation

- T: Time between the active edge of SCLKX after $\overline{\text{SYPX}}$ pulse begin and beginning of the next frame (F-bit, channel phase 0), measured in number of SCLKX clock intervals; maximum delay: $T_{\text{max}} = (200 \times \text{SC}/\text{BF}) - (7 \times \text{SC}/\text{BF}) - 1$
- BF: Basic frequency; 1.544 Mbit/s
- SC: System clock rate; 1.544, 3.088, 6.176, or 12.352 MHz
- X: Programming value to be written to registers RC0 and RC1 (see [page 356](#)).

$$0 \leq T \leq 4: \quad X = 3 - T + (7 \times \text{SC}/\text{BF})$$

$$5 \leq T \leq T_{\text{max}}: \quad X = (200 \times \text{SC}/\text{BF}) - T + 3$$

Functional Description T1/J1

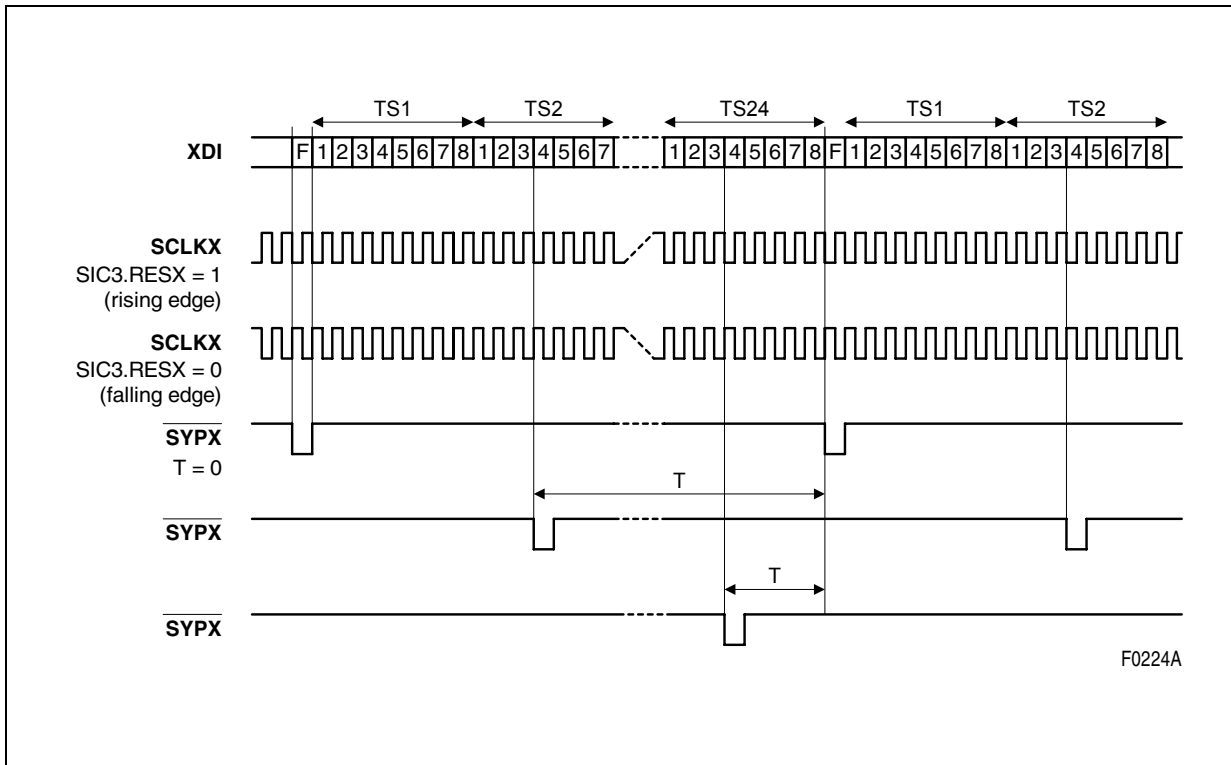

Figure 70 **SYPX** Offset Programming (1.544 Mbit/s, 1.544 MHz)

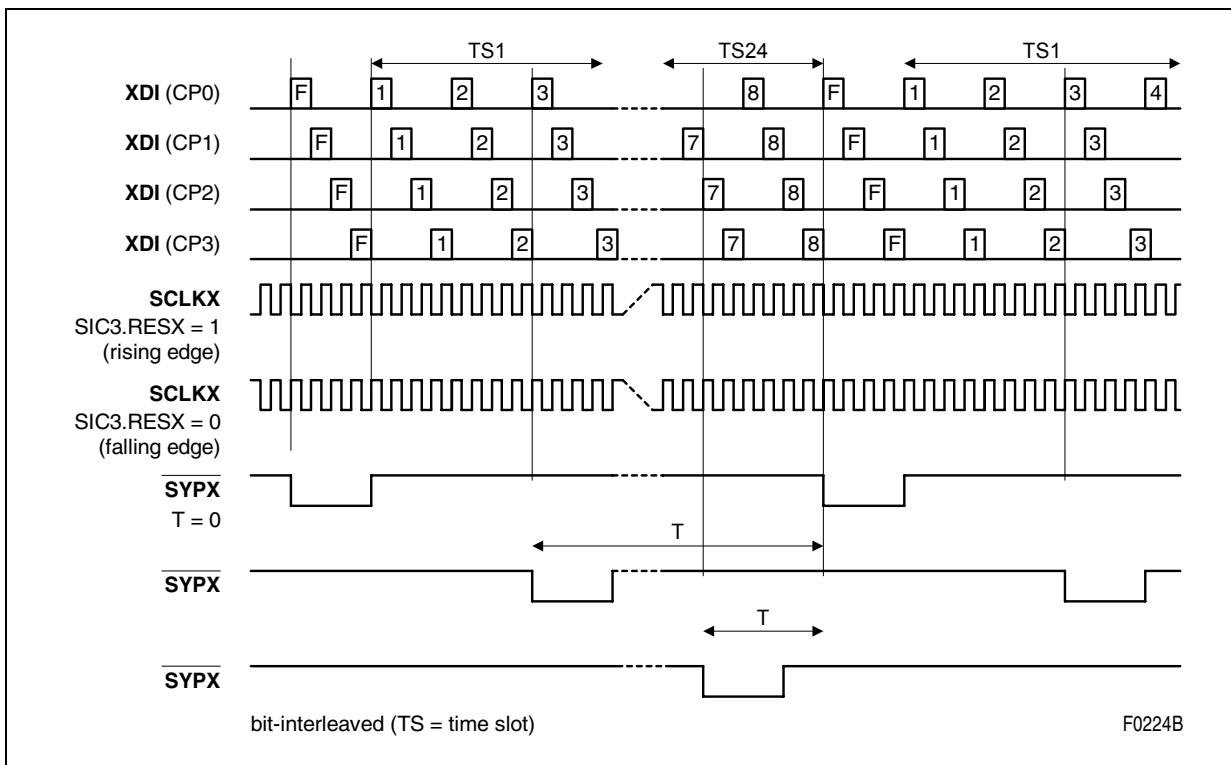

Figure 71 **SYPX** Offset Programming (6.176 Mbit/s, 6.176 MHz)

5.5.3 Time Slot Assigner (T1/J1)

HDLC channel 1 offers the flexibility to connect data during certain time slots, as defined by registers RTR(4:1) and TTR(4:1), to the RFIFO and XFIFO, respectively. Any combinations of time slots can be programmed for the receive and transmit directions. If CCR1.EITS = 1 the selected time slots (RTR(4:1)) are stored in the RFIFO of the signaling controller and the XFIFO contents is inserted into the transmit path as controlled by registers TTR(4:1).

For HDLC channels 2 and 3, one out of 24 time slots can be selected for each channel, but in common for transmit and receive direction.

Within selected time slots single bit positions can be masked to be used/not used for HDLC transmission for all HDLC channels. Additionally, the use of even, odd or both frames can be selected for each HDLC channel individually.

Table 45 Time Slot Assigner HDLC Channel 1 (T1/J1)

Receive Time Slot Register	Transmit Time Slot Register	Time Slots	Receive Time Slot Register	Transmit Time Slot Register	Time Slots
RTR 1.7	TTR 1.7	0	RTR 3.7	TTR 3.7	16
RTR 1.6	TTR 1.6	1	RTR 3.6	TTR 3.6	17
RTR 1.5	TTR 1.5	2	RTR 3.5	TTR 3.5	18
RTR 1.4	TTR 1.4	3	RTR 3.4	TTR 3.4	19
RTR 1.3	TTR 1.3	4	RTR 3.3	TTR 3.3	20
RTR 1.2	TTR 1.2	5	RTR 3.2	TTR 3.2	21
RTR 1.1	TTR 1.1	6	RTR 3.1	TTR 3.1	22
RTR 1.0	TTR 1.0	7	RTR 3.0	TTR 3.0	23
RTR 2.7	TTR 2.7	8	RTR 4.7	TTR 4.7	24
RTR 2.6	TTR 2.6	9	RTR 4.6	TTR 4.6	25
RTR 2.5	TTR 2.5	10	RTR 4.5	TTR 4.5	26
RTR 2.4	TTR 2.4	11	RTR 4.4	TTR 4.4	27
RTR 2.3	TTR 2.3	12	RTR 4.3	TTR 4.3	28
RTR 2.2	TTR 2.2	13	RTR 4.2	TTR 4.2	29
RTR 2.1	TTR 2.1	14	RTR 4.1	TTR 4.1	30
RTR 2.0	TTR 2.0	15	RTR 4.0	TTR 4.0	31

Functional Description T1/J1

The format for receive FS/DL data transmission in time slot 0 of the system interface is as shown in **Figure 63** below. In order to get an undisturbed reception even in the asynchronous state bit FMR2.DAIS has to be set.

5.6 Test Functions (T1/J1)

5.6.1 Pseudo-Random Binary Sequence Generation and Monitor

The FALC56 has the added ability to generate and monitor a $2^{15}-1$ and $2^{20}-1$ Pseudo-Random Binary Sequences (PRBS). The generated PRBS pattern is transmitted to the remote end on pins XL1/2 or XDOP/N and can be inverted optionally. Generating and monitoring of PRBS pattern is done according to ITU-T O.151 and TR62411 with maximum 14 consecutive zero restriction.

The PRBS monitor senses the PRBS pattern in the incoming data stream. Synchronization is done on the inverted and non-inverted PRBS pattern. The current synchronization status is reported in status and interrupt status registers. Enabled by bit LCR1.EPRM each PRBS bit error increments an error counter (BEC). Synchronization is reached within 400 ms with a probability of 99.9% and a bit error rate of up to 10^{-1} .

The PRBS generator and monitor can be used to handle either a framed (TPC0.FRA = 1) or an unframed (TPC0.FRA = 0) data stream.

5.6.2 Remote Loop

In the remote loop-back mode the clock and data recovered from the line inputs RL1/2 or RDIP/RDIN are routed back to the line outputs XL1/2 or XDOP/XDON through the analog or digital transmitter. As in normal mode they are also processed by the synchronizer and then sent to the system interface. The remote loop-back mode is selected by setting the corresponding control bits LIM1.RL+JATT. Received data is looped with or without use of the transmit jitter attenuator (FIFO).

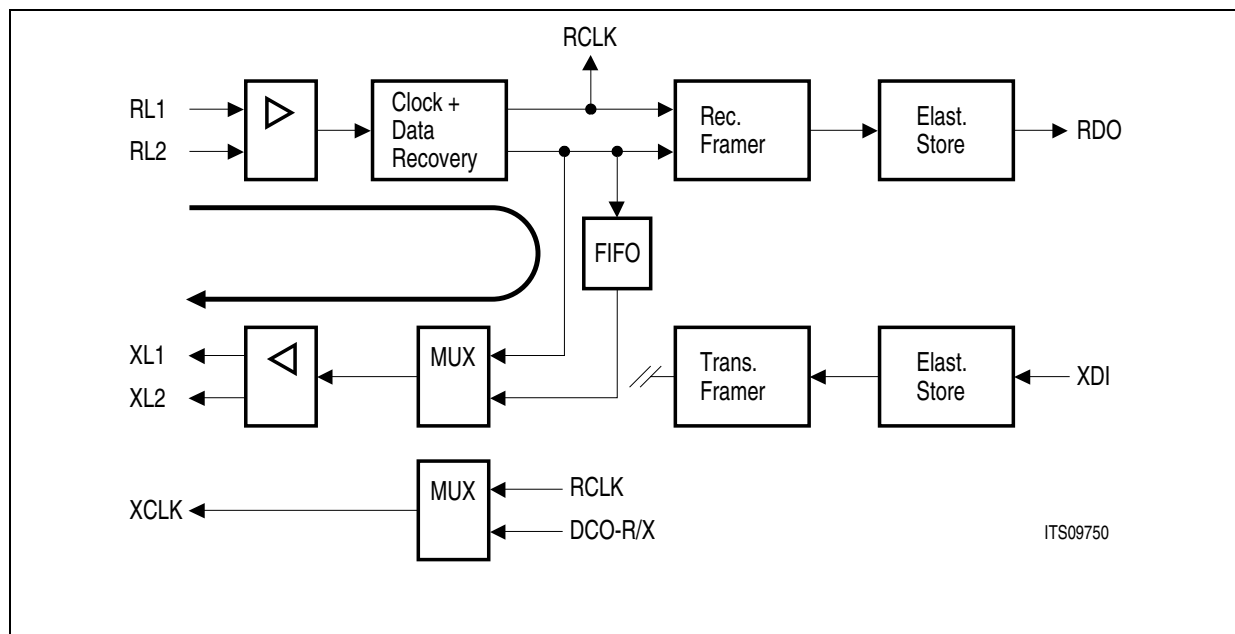

Figure 72 Remote Loop (T1/J1)

5.6.3 Payload Loop-Back

To perform an effective circuit test a line loop is implemented.

If the payload loop-back (FMR2.PLB) is activated the received 192 bits of payload data is looped back to the transmit direction. The framing bits, CRC6 and DL-bits are not looped, if FMR4.TM = 0. They are originated by the FALC56 transmitter. If FMR4.TM = 1 the received FS/DL-bit is sent transparently back to the line interface. Following pins are ignored: XDI, XSIG, TCLK, SCLKX, SYPX and XMFS. All the received data is processed normally. With bit FMR2.SAIS an AIS can be sent to the system interface on pin RDO.

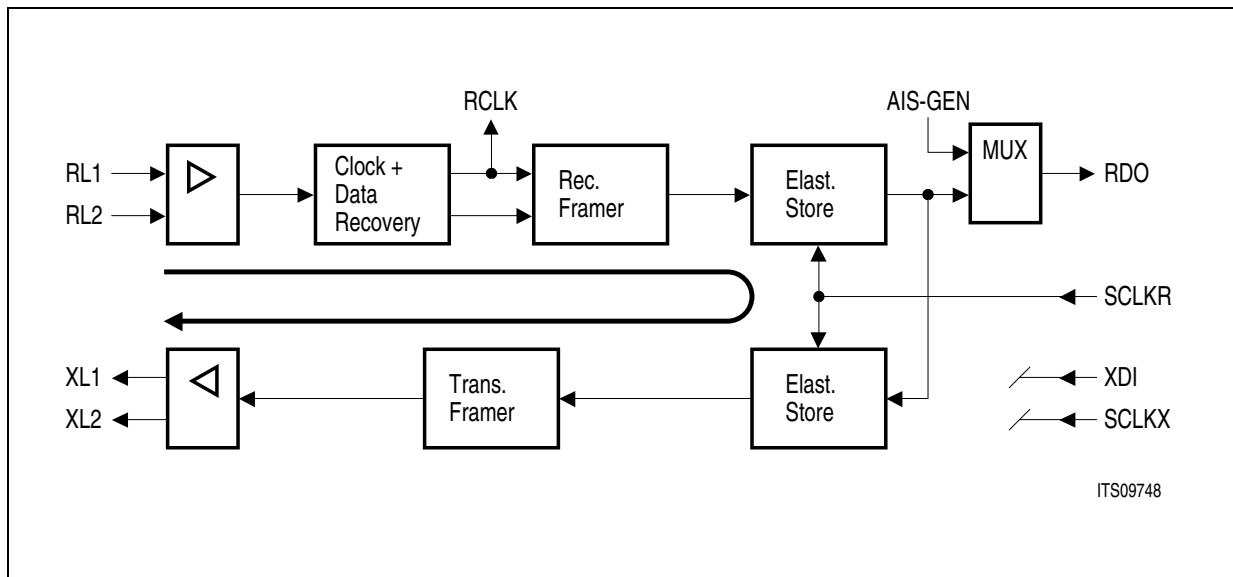

Figure 73 Payload Loop (T1/J1)

5.6.4 Local Loop

The local loop-back mode, selected by LIM0.LL = 1, disconnects the receive lines RL1/2 or RDIP/RDIN from the receiver. Instead of the signals coming from the line the data provided by system interface are routed through the analog receiver back to the system interface. However, the bit stream is transmitted undisturbedly on the line. An AIS to the distant end can be enabled by setting FMR1.XAIS without influencing the data looped back to the system interface.

Note that enabling the local loop usually invokes an out of frame error until the receiver resynchronizes to the new framing. The serial codes for transmitter and receiver have to be identical.

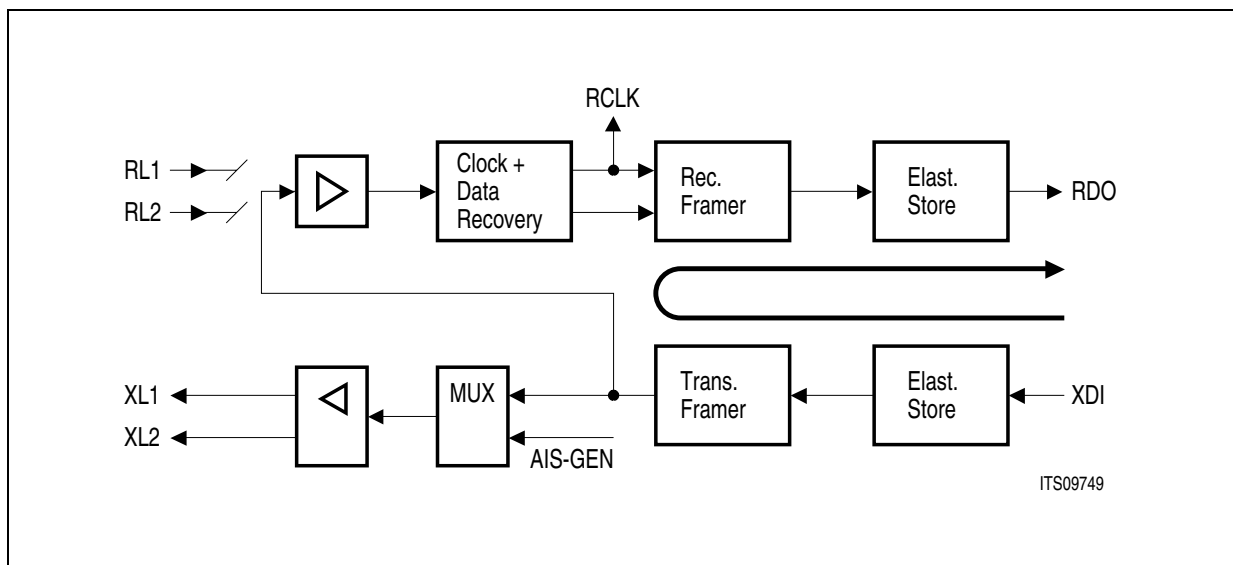

Figure 74 Local Loop (T1/J1)

5.6.5 Single Channel Loop-Back (loop-back of time slots)

The channel loop-back is selected by LOOP.ECLB = 1.

Each of the 24 time slots can be selected for loop-back from the system PCM input (XDI) to the system PCM output (RDO). This loop-back is programmed for one time slot at a time selected by register LOOP. During loop-back, an idle channel code programmed in register IDLE is transmitted to the remote end in the corresponding PCM route time slot.

For the time slot test, sending sequences of test patterns like a 1-kHz check signal should be avoided. Otherwise an increased occurrence of slips in the tested time slot disturbs testing. These slips do not influence the other time slots and the function of the receive memory. The usage of a quasi-static test pattern is recommended.

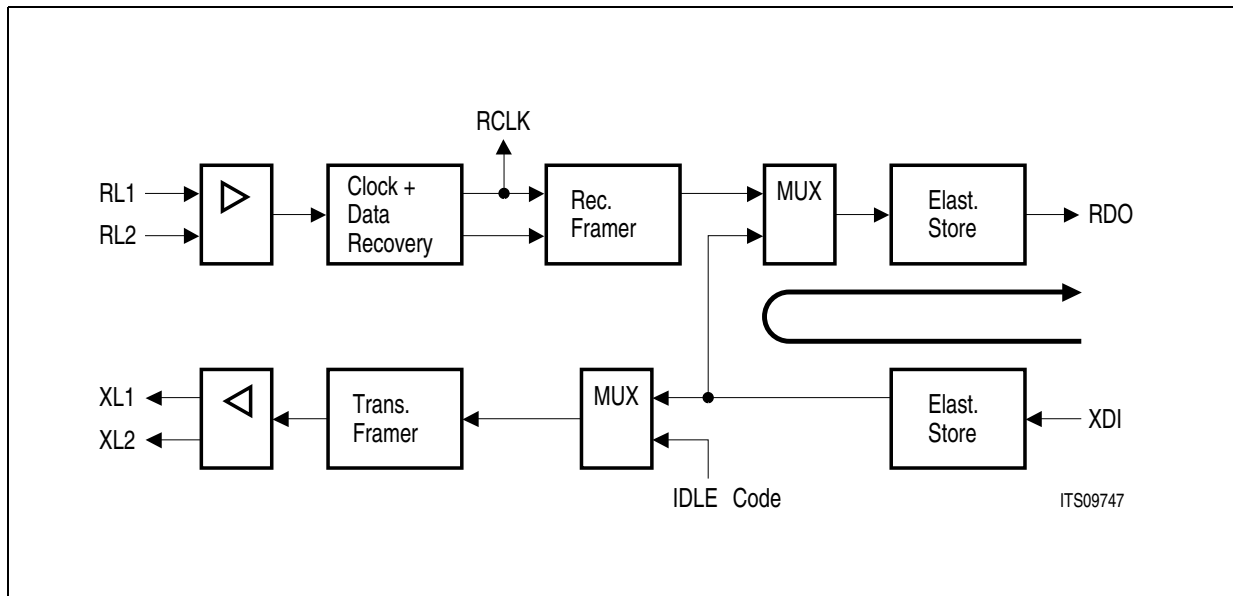

Figure 75 Channel Loop-Back (T1/J1)

5.6.6 Alarm Simulation (T1/J1)

Alarm simulation does not affect the normal operation of the device, i.e. all time slots remain available for transmission. However, possible real alarm conditions are not reported to the processor or to the remote end when the device is in the alarm simulation mode.

The alarm simulation is initiated by setting the bit FMR0.SIM. The following alarms are simulated:

- Loss-Of-Signal (LOS, red alarm)
- Alarm indication signal (AIS, blue alarm)
- Loss of pulse frame
- Remote alarm (yellow alarm) indication
- Receive and transmit slip indication
- Framing error counter
- Code violation counter
- CRC6 error counter

Some of the above indications are only simulated if the FALC56 is configured in a mode where the alarm is applicable.

The alarm simulation is controlled by the value of the alarm simulation counter: FRS2.ESC which is incremented by setting bit FMR0.SIM.

Clearing of alarm indications:

- Automatically for LOS, remote (yellow) alarm, AIS, and loss of synchronization and
- User controlled for slips by reading the corresponding interrupt status register ISR3.
- Error counter have to be cleared by reading the corresponding counter registers.

is only possible at defined counter steps of FRS2.ESC. For complete simulation (FRS2.ESC = 0), eight simulation steps are necessary.

5.6.7 Single Bit Defect Insertion

Single bit defects can be inserted into the transmit data stream for the following functions:

FAS defect, multiframe defect, CRC defect, CAS defect, PRBS defect and bipolar violation.

Defect insertion is controlled by register IERR.

5.7 J1-Feature Overview

The Japanese J1 standard is very similar to the T1 standard, but differs in some details. To support these differences easily, the following features are provided within the FALC56:

- CRC6 generation and checking according to ITU-JT G.706
(CRC checksum calculation includes FS/DL-bits, see [Chapter 5.2.6.3](#) on [page 146](#))
- Remote alarm handling according to ITU-JT G.704
(remote alarm pattern in DL-channel is "1111111111111111", see [Chapter 5.2.6.2](#) on [page 146](#))
- NTT synchronization requirements in ESF framing mode
- Pulse shaping according to JT G.704
- Receive input thresholds according to ITU-JT G.703

J1 mode is globally selected by setting $RC0.SJR = 1$ (see [page 357](#)). For specific J1 framer initialization see [Table 55](#) on [page 199](#).

No special pulse mask setting is required, the described T1-settings also fulfill the J1 requirements.

6 Operational Description E1

6.1 Operational Overview E1

The FALC56 can be operated in two modes, which are either E1 mode or T1/J1 mode. The device is programmable via a microprocessor interface which enables byte or word access to all control and status registers.

After reset the FALC56 must be initialized first. General guidelines for initialization are described in [Chapter 6.3](#).

The status registers are read-only and are updated continuously. Normally, the processor reads the status registers periodically to analyze the alarm status and signaling data.

6.2 Device Reset E1

The FALC56 is forced to the reset state if a low signal is input on pin $\overline{\text{RES}}$ for a minimum period of 10 μs . During reset the FALC56 needs an active clock on pin MCLK. All output stages are in a high-impedance state, all internal flip-flops are reset and most of the control registers are initialized with default values.

Signals (for example RL1/2 receive line) should not be applied before the device is powered up.

After reset the device is initialized to E1 operation.

6.3 Device Initialization in E1 Mode

After reset, the FALC56 is initialized for doubleframe format with register values listed in the following table.

Table 46 Initial Values after Reset (E1)

Register	Reset Value	Meaning
FMR0	00 _H	NRZ Coding, no alarm simulation.
FMR1 FMR2	00 _H	E1-doubleframe format, 2 Mbit/s system data rate, no AIS transmission to remote end or system interface, payload loop off.
SIC1 SIC2, SIC3	00 _H 00 _H 00 _H	8.192 MHz system clocking rate, receive buffer 2 frames, transmit buffer bypass, data sampled or transmitted on the falling edge of SCLKR/X, automatic freeze signaling, data is active in the first channel phase

Operational Description E1
Table 46 Initial Values after Reset (E1) (cont'd)

Register	Reset Value	Meaning
LOOP	00 _H	Channel loop-back and single frame mode are disabled.
XSW	00 _H	All bits of the transmitted service word are cleared. Spare bit values are cleared.
XSP	00 _H	
TSWM	00 _H	
XC0	00 _H	The transmit clock offset is cleared.
XC1	9C _H	The transmit time slot offset is cleared.
RC0	00 _H	The receive clock slot offset is cleared.
RC1	9C _H	The receive time slot offset is cleared.
IDLE	00 _H	Idle channel code is cleared.
ICB(4:1)	00 _H	Normal operation (no "Idle Channel" selected).
LIM0	00 _H	Slave Mode, local loop off Analog interface selected, remote loop off Pulse count for LOS detection cleared Pulse count for LOS recovery cleared
LIM1	00 _H	
PCD	00 _H	
PCR	00 _H	
XPM(2:0)	40 _H , 03 _H , 7B _H	Transmit pulse mask (transmitter in tristate mode)
IMR(5:0)	FF _H	All interrupts are disabled
RTR(4:1)	all 00 _H	No time slots selected
TTR(4:1)	all 00 _H	
TSS2	00 _H	
TSS3	00 _H	
GCR	00 _H	Internal second timer, power on
CMR1	00 _H	RCLK output: DPLL clock, DCO-X enabled, DCO-X internal reference clock
CMR2	00 _H	SCLKR selected, SCLKX selected, receive synchronization pulse sourced by $\overline{\text{SYPR}}$, transmit synchronization pulse sourced by $\overline{\text{SYPX}}$
PC(4:1)	00 _H , 00 _H 00 _H , 00 _H	Input function of ports RP(A to D): $\overline{\text{SYPR}}$, Input function of ports XP(A to D): $\overline{\text{SYPX}}$
PC5	00 _H	SCLKR, SCLKX, RCLK configured to inputs, XMFS active low, CLK1 and CLK2 pin configuration
PC6	00 _H	
MODE	00 _H	Signaling controller disabled
MODE2	00 _H	
MODE3	00 _H	

Operational Description E1

Table 46 Initial Values after Reset (E1) (cont'd)

Register	Reset Value	Meaning
RAH(2:1) RAL(2:1)	FD _H , FF _H FF _H , FF _H	Compare register for receive address cleared
GCM(6:1)	all 00 _H	Fixed clock mode selected (2.048 MHz on pin MCLK required).

E1 Initialization

For a correct start up of the primary access interface a set of parameters specific to the system and hardware environment must be programmed after reset goes inactive. Both the basic and the operational parameters must be programmed **before** the activation procedure of the PCM line starts. Such procedures are specified in ITU-T and ETSI recommendations (e.g. fault conditions and consequent actions). Setting optional parameters primarily makes sense when basic operation via the PCM line is guaranteed. **Table 47** gives an overview of the most important parameters in terms of signals and control bits which are to be programmed in one of the above steps. The sequence is recommended but not mandatory. Accordingly, parameters for the basic and operational set up, for example, can be programmed simultaneously. The bit FMR1.PMOD should always be kept low (otherwise T1/J1 mode is selected).

Table 47 Initialization Parameters (E1)

Basic Set Up	
Master clocking mode	GCM(6:1) according to external MCLK clock frequency
E1 mode select	FMR1.PMOD = 0
Specification of line interface and clock generation	LIM0, LIM1, XPM(2:0)
Line interface coding	FMR0.XC(1:0), FMR0.RC(1:0)
Loss-of-signal detection/recovery conditions	PCD, PCR, LIM1, LIM2
System clocking and data rate	SIC1.SSCC(1:0), SIC1.SSD1, FMR1.SSD0 CMR2.IRSP/IRSC/IXSP/IXSC
Transmit offset counters	XC0.XCO, XC1.XTO
Receive offset counters	RC0.RCO, RC1.RTO
AIS to system interface	FMR2.DAIS/SAIS

Operational Description E1

Table 47 Initialization Parameters (E1) (cont'd)

Operational Set Up	
Select framing	FMR2.RFS(1:0), FMR1.XFS
Framing additions	RC1.ASY4, RC1.SWD
Synchronization mode	FMR1.AFR, FMR2.ALMF
Signaling mode	XSP, XSW, FMR1.ENSA, XSA(8:4), TSWM, MODE, CCR1, CCR2, RAH(2:1), RAL(2:1)

Features like channel loop-back, idle channel activation, extensions for signaling support, alarm simulation, etc. are activated later. Transmission of alarms (e.g. AIS, remote alarm) and control of synchronization in connection with consequent actions to remote end and internal system depend on the activation procedure selected.

Note: Read access to unused register addresses: value should be ignored.

Write access to unused register addresses: should be avoided, or set to "00" hex.

All control registers (except XFIFO, XS(16:1), CMDR, DEC) are of type Read/Write.

Specific E1 Register Settings

The following is a suggestion for a basic initialization to meet most of the E1 requirements. Depending on different applications and requirement any other initialization can be used.

Table 48 Line Interface Initialization (E1)

FMR0.XC0/ FMR0.RC0/ LIM1.DRS FMR3.CMI	The FALC56 supports requirements for the analog line interface as well as the digital line interface. For the analog line interface the codes AMI and HDB3 are supported. For the digital line interface modes (dual- or single-rail) the FALC56 supports AMI, HDB3, CMI (with and without HDB3 precoding) and NRZ.
PCD = 0A _H	LOS detection after 176 consecutive "zeros" (fulfills G.775).
PCR = 15 _H	LOS recovery after 22 "ones" in the PCD interval. (fulfills G.775).
LIM1.RIL(2:0) = 02 _H	LOS threshold of 0.6 V (fulfills G.775).

E1 Framer Initialization

The selection of the following modes during the basic initialization supports the ETSI requirements for E-Bit Access, remote alarm and synchronization (please refer also to FALC56 driver code of the evaluation system EASY22554 and application notes) and

Operational Description E1

helps to reduce the software load. They are very helpful especially to meet requirements as specified in ETS300 011.

Table 49 Framer Initialization (E1)

XSP.AXS = 1	ETS300 011 C4.x for instance requires the sending of E-Bits in TS0 if CRC4 errors have been detected. By programming XSP.AXS = 1 the submultiframe status is inserted automatically in the next outgoing multiframe.
XSP.EBP = 1	If the FALC56 has reached asynchronous state the E-Bit is cleared if XSP.EBP = 0 and set if XSP.EBP = 1. ETS300 011 requires that the E-Bit is set in asynchronous state.
FMR2.AXRA = 1	The transmission of RAI via the line interface is done automatically by the FALC56 in case of loss of frame alignment (FRS0.LFA = 1). If basic framing has been reinstalled RAI is automatically reset.
FMR2.FRS(2:1) = 10 FMR1.AFR = 1	In this mode a search of double framing is automatically restarted, if no CRC4 multiframe is found within 8ms. Together with FMR2.AXRA = 1 this mode is essential to meet ETS300 011 and reduces the processor load heavily.
FMR2.ALMF = 1	The receiver initiates a new basic- and multiframe research if more than 914 CRC4 errors have been detected in one second.
FMR2.FRS1/0 = 11	In the interworking mode the FALC56 stays in double framing format if no multiframe pattern is found in a time interval of 400 ms. This is also indicated by a 400 ms interrupt. Additionally the extended interworking mode (FMR3.EXTIW = 1) will activate after 400 ms the remote alarm (FMR2.AXRA = 1) and will still search the multiframe without switching completely to the double framing. A complete resynchronization in an 8 ms interval is not initiated.

Table 50 HDLC Controller Initialization (E1)

MODE = 88 _H MODE2= 88 _H MODE3= 88 _H	HDLC channel 1 receiver active, no address comparison. HDLC channel 2 receiver active, no address comparison. HDLC channel 2 receiver active, no address comparison.
CCR1 = 18 _H CCR3= 08 _H CCR4= 08 _H	Enable signaling via TS(31:0), interframe time fill with continuous flags (channel 1). Interframe time fill with continuous flags (channel 2). Interframe time fill with continuous flags (channel 3).

Operational Description E1

Table 50 HDLC Controller Initialization (E1) (cont'd)

IMR0.RME = 0 IMR0.RPF = 0 IMR1.XPR = 0 IMR4.RME2=0 IMR4.RPF2=0 IMR5.XPR2=0 IMR5.RME3=0 IMR5.RPF3=0 IMR5.XPR3=0	Unmask interrupts for HDLC processor requests.
RTR3.TS16 = 1 TTR3.TS16 = 1 TSEO = 00 _H TSBS1 = FF _H TSBS2= FF _H TSBS3= FF _H TSS2= 01 _H TSS3= 02 _H	Select TS16 for HDLC data reception and transmission. Even and odd frames are used for HDLC reception and transmission. Select all bits of selected time slot (channel 1). Select all bits of selected time slot (channel 2). Select all bits of selected time slot (channel 3). Select time slot 1 for HDLC channel 2. Select time slot 2 for HDLC channel 3.

Table 51 CAS-CC Initialization (E1)

XSP.CASEN = 1 CCR1.EITS = 0	Send CAS info stored in the XS(16:1) registers.
IMR0.CASC = 0	Enable interrupt with any data change in the RS(16:1) registers.

Note: After the device initialization a software reset should be executed by setting of bits CMDR.XRES/RRES.

7 Operational Description T1/J1

7.1 Operational Overview T1/J1

The FALC56 can be operated in two principle modes, which are either E1 mode or T1/J1 mode.

The device is programmable via a microprocessor interface which enables byte or word access to all control and status registers.

After reset the FALC56 must be initialized first. General guidelines for initialization are described in [Chapter 7.3](#)

The status registers are read-only and are updated continuously. Normally, the processor reads the status registers periodically to analyze the alarm status and signaling data.

7.2 Device Reset T1/J1

The FALC56 is forced to the reset state if a low signal is input on pin $\overline{\text{RES}}$ for a minimum period of 10 μs . During reset the FALC56 needs an active clock on pin MCLK. All output stages are in a high-impedance state, all internal flip-flops are reset and most of the control registers are initialized with default values.

Signals (for example RL1/2 receive line) should not be applied before the device is powered up.

After reset the device is initialized to E1 operation.

7.3 Device Initialization in T1/J1 Mode

After reset, the FALC56 is initialized for E1 doubleframe format. To initialize T1/J1 mode, bit FMR1.PMOD has to be set high. After the internal clocking is settled to T1/J1 mode (takes up to 20 μs), the following register values are initialized:

Table 52 Initial Values after reset and FMR1.PMOD = 1 (T1/J1)

Register	Initiated Value	Meaning
FMR0	00 _H	NRZ coding, no alarm simulation
FMR1 FMR2	00 _H 00 _H	PCM24 mode, 2.048 Mbit/s system data rate, no AIS transmission to remote end or system interface, payload loop off, channel translation mode 0

Operational Description T1/J1
Table 52 Initial Values after reset and FMR1.PMOD = 1 (T1/J1) (cont'd)

Register	Initiated Value	Meaning
SIC1 SIC2, SIC3	00 _H 00 _H 00 _H	2.048 MHz system clocking rate, receive buffer 2 frames, transmit buffer bypass, data sampled or transmitted on the falling edge of SCLKR/X, automatic freeze signaling, data is active in the first channel phase
LOOP	00 _H	loop-backs are disabled.
FMR4 FMR5	00 _H 00 _H	Remote alarm indication towards remote end is disabled. LFA condition: 2 out of 4/5/6 framing bits, non-auto-synchronization mode, F12 multiframing, internal bit robbing access disabled
XC0 XC1	00 _H 9C _H	The transmit clock slot offset is cleared. The transmit time slot offset is cleared.
RC0 RC1	00 _H 9C _H	The receive clock slot offset is cleared. The receive time slot offset is cleared.
IDLE ICB(3:1)	00 _H 00 _H	Idle channel code is cleared. Normal operation (no "Idle Channels" selected).
CCB(3:1)	00 _H	Normal operation (no clear channel operation).
LIM0 LIM1 PCD PCR	00 _H 00 _H 00 _H 00 _H	Slave mode, local loop off, analog interface selected, remote loop off pulse count for LOS detection cleared pulse count for LOS recovery cleared
XPM(2:0)	40 _H , 03 _H , 7B _H	Transmit pulse mask (transmitter in tristate mode)
IMR(5:0)	FF _H	All interrupts are disabled
GCR	00 _H	Internal second timer, power on
CMR1	00 _H	RCLK output: DPLL clock, DCO-X enabled, DCO-X internal reference clock
CMR2	00 _H	SCLKR selected, SCLKX selected, receive synchronization pulse sourced by $\overline{\text{SYPR}}$, transmit synchronization pulse sourced by $\overline{\text{SYPX}}$
GPC1	00 _H	SEC port input active high
PC(4:1)	00 _H , 00 _H 00 _H , 00 _H	Input function of ports RP(A to D): $\overline{\text{SYPR}}$, Input function of ports XP(A to D): $\overline{\text{SYPX}}$
PC5 PC6	00 _H 00 _H	SCLKR, SCLKX, RCLK configured to inputs, XMFS active low, CLK1 and CLK2 pin configuration

Table 52 Initial Values after reset and FMR1.PMOD = 1 (T1/J1) (cont'd)

Register	Initiated Value	Meaning
MODE MODE2 MODE3	00 _H 00 _H 00 _H	Signaling controller disabled
RAH(2:1) RAL(2:1)	FD _H , FF _H FF _H , FF _H	Compare register for receive address cleared
GCM(6:1)	all 00 _H	Fixed clock mode selected (1.544 MHz on pin MCLK required).
RTR(4:1) TTR(4:1) TSS2 TSS3	all 00 _H all 00 _H 00 _H 00 _H	No time slots selected

T1/J1 Initialization

For a correct start up of the primary access interface a set of parameters specific to the system and hardware environment must be programmed after $\overline{\text{RES}}$ goes inactive (high). Both the basic and the operational parameters must be programmed **before** the activation procedure of the PCM line starts. Such procedures are specified in ITU-T recommendations (e.g. fault conditions and consequent actions). Setting optional parameters primarily makes sense when basic operation via the PCM line is guaranteed.

Table 53 gives an overview of the most important parameters in terms of signals and control bits which are to be programmed in one of the above steps. The sequence is recommended but not mandatory. Accordingly, parameters for the basic and operational set up, for example, can be programmed simultaneously. The bit FMR1.PMOD must always be kept high (otherwise E1 mode is selected). J1 mode is selected by additionally setting RC0.SJR = 1.

Features like channel loop-back, idle channel activation, clear channel activation, extensions for signaling support, alarm simulation, etc. are activated later. Transmission of alarms (e.g. AIS, remote alarm) and control of synchronization in connection with consequent actions to remote end and internal system depend on the activation procedure selected.

Operational Description T1/J1
Table 53 Initialization Parameters (T1/J1)

Basic Set Up	T1	J1
Master clocking mode	GCM(6:1) according to external MCLK clock frequency	
T1/J1 mode select	FMR1.PMOD = 1, RC0.SJR = 0	FMR1.PMOD = 1, RC0.SJR = 1
Specification of line interface and clock generation	LIM0, LIM1, XPM(2:0)	
Line interface coding	FMR0.XC(1:0), FMR0.RC(1:0)	
Loss-of-signal detection/recovery conditions	PCD, PCR, LIM1, LIM2	
System clocking and data rate	SIC1.SSC(1:0), SIC1.SSD1, FMR1.SSD0, CMR1.IRSP/IRSC/IXSP/IXSC	
Channel translation mode	FMR1.CTM	
Transmit offset counters	XC0.XCO, XC1.XTO	
Receive offset counters	RC0.RCO, RC1.RTO	
AIS to system interface	FMR2.DAIS/SAIS	
Operational Set Up		
Select framing	FMR4.FM(1:0)	
Framing additions	FMR1.CRC, FMR0.SRAF	
Synchronization mode	FMR4.AUTO, FMR4.SSC(1:0), FMR2.MCSP, FMR2.SSP	
Signaling mode	FMR5.EIBR, XC0.BRM, MODE, MODE2, MODE3, CCR1, CCR2, RAH(2:1), RAL(2:1)	

Note: Read access to unused register addresses: value should be ignored.
 Write access to unused register addresses: should be avoided, or set to "00"hex.
 All control registers (except XFIFO, XS(12:1), CMDR, DEC) are of type read/write

Specific T1/J1 Initialization

The following is a suggestion for a basic initialization to meet most of the T1/J1 requirements. Depending on different applications and requirements any other initialization can be used.

Table 54 Line Interface Initialization (T1/J1)

Register	Function
FMR0.XC0/1 FMR0.RC0/1 LIM1.DRS CCB(3:1) SIC3.CMI	The FALC56 supports requirements for the analog line interface as well as the digital line interface. For the analog line interface the codes AMI (with and without bit 7stuffing) and B8ZS are supported. For the digital line interface modes (dual- or single-rail) the FALC56 supports AMI (with and without bit 7 stuffing), B8ZS (with and without B8ZS precoding) and NRZ.
PCD = 0A _H	LOS detection after 176 consecutive “zeros” (fulfills G.775/ Telcordia (Bellcore)/AT&T)
PCR = 15 _H	LOS recovery after 22 “ones” in the PCD interval (fulfills G.775, Bellcore/AT&T).
LIM1.RIL(2:0) = 02 _H	LOS threshold of 0.6 V (fulfills G.775).
GCR.SCI = 1	Additional Recovery Interrupts. Help to meet alarm activation and deactivation conditions in time.
LIM2.LOS1 = 1	Automatic pulse-density check on 15 consecutive zeros for LOS recovery condition (Bellcore requirement)

Table 55 Framer Initialization (T1/J1)

Register	Function	
	T1	J1
FMR4.SSC1/0	Selection of framing sync conditions	
FMR4.FM1/0	Select framing format	
FMR2.AXRA = 1	The transmission of RAI via the line interface is done automatically by the FALC56 in case of Loss of Frame Alignment (FRS0.LFA = 1). If framing has been reinstalled RAI is automatically reset	
FMR4.AUTO = 1	Automatic synchronization in case of definite framing candidate (FRS0.FSRF). In case of multiple framing candidates and CRC6 errors different resynchronization conditions can be programmed via FMR2.MCSP/SSP.	
RCO.SJR ¹⁾ = 1 FMR0.SRAF = 0 XSW.XRA = 1		Remote alarm handling via DL-channel according to ITU-T JG.704 using pattern "1111111111111111"
RCO.SJR = 0	CRC6 calculation without FS/DL-bits	
RCO.SJR = 1		CRC6 calculation including FS/DL-bits
FMR4.AUTO = 1	Automatic synchronization in case of definite framing candidate (FRS0.FSRF). In case of multiple framing candidates and CRC6 errors different resynchronization conditions can be programmed via FMR2.MCSP/SSP.	
FMR4.SSC1 = 1 FMR4.SSC0 = 1 FMR2.MCSP = 0 FMR2.SSP = 1		Synchronization and resynchronization conditions, for details see register description

¹⁾ Remote alarm handling and CRC6 calculation are commonly selected by RCO.SJR

Operational Description T1/J1

Table 56 HDLC Controller Initialization (T1/J1)

MODE = 88 _H MODE2= 88 _H MODE3= 88 _H	HDLC channel 1 receiver active, no address comparison. HDLC channel 2 receiver active, no address comparison. HDLC channel 2 receiver active, no address comparison.
CCR1 = 18 _H CCR3= 08 _H CCR4= 08 _H	Enable signaling via TS(24:1), interframe time fill with continuous flags (channel 1). Interframe time fill with continuous flags (channel 2). Interframe time fill with continuous flags (channel 3).
IMR0.RME = 0 IMR0.RPF = 0 IMR1.XPR = 0 IMR4.RME2=0 IMR4.RPF2=0 IMR5.XPR2=0 IMR5.RME3=0 IMR5.RPF3=0 IMR5.XPR3=0	Unmask interrupts for HDLC processor requests.
RTR4.0 = 1 TTR4.0 = 1 TSEO = 00 _H TSBS1 = FF _H TSBS2= FF _H TSBS3= FF _H TSS2= 01 _H TSS3= 02 _H	Select time slot 24 for HDLC data reception and transmission. Even and odd frames are used for HDLC reception and transmission. Select all bits of selected time slot (channel 1). Select all bits of selected time slot (channel 2). Select all bits of selected time slot (channel 3). Select time slot 1 for HDLC channel 2. Select time slot 2 for HDLC channel 3.

Table 57 Initialization of the CAS-BR Controller (T1/J1)

FMR5.EIBR = 1	Enable CAS-BR Mode Send CAS-BR information stored in XS(12:1)
IMR1.CASE = 0 IMR0.RSC = 0	Enable interrupts which indicate the access to the XS(12:1) CAS-BR registers and any data change in RS(12:1)

Note: After the device initialization a software reset should be executed by setting of bits CMDR.XRES/RRES.

8 Signaling Controller Operating Modes

The three HDLC controllers can be programmed to operate in various modes, which are different in the treatment of the HDLC frame in receive direction. Thus, the receive data flow and the address recognition features can be performed in a very flexible way, to satisfy almost any practical requirements.

There are 4 different operating modes which can be set via the mode registers (MODE, MODE2 and MODE3).

If not mentioned otherwise, all functions described for HDLC channel 1 apply to channel 2 and 3 as well.

8.1 HDLC Mode

All frames with valid addresses are forwarded directly via the RFIFO to the system memory.

Depending on the selected address mode, the FALC56 can perform a 1- or 2-byte address recognition (MODE.MDS0).

If a 2-byte address field is selected, the high address byte is compared to the fixed value FEH or FCH (group address) as well as with two individually programmable values in RAH1 and RAH2 registers. According to the ISDN LAPD protocol, bit 1 of the high byte address is interpreted as command/response bit (C/R) and is excluded from the address comparison.

Similarly, two compare values can be programmed in special registers (RAL1, RAL2) for the low address byte. A valid address is recognized in case the high and low byte of the address field correspond to one of the compare values. Thus, the FALC56 can be called (addressed) with 6 different address combinations. HDLC frames with address fields that do not match any of the address combinations, are ignored by the FALC56.

In case of a 1-byte address, RAL1 and RAL2 are used as compare registers. The HDLC control field, data in the I-field and an additional status byte are temporarily stored in the RFIFO. Additional information can also be read from a special register (RSIS).

As defined by the HDLC protocol, the FALC56 performs the zero bit insertion/deletion (bit stuffing) in the transmit/receive data stream automatically. That means, it is guaranteed that at least one "0" will appear after 5 consecutive "1"s.

8.1.1 Non-Auto Mode

(MODE.MDS(2:1) = 01; MODE2.MDS22..21=01; MODE3.MDS32..31=01)

Characteristics: address recognition, flag- and CRC generation/check, bit stuffing

All frames with valid addresses are forwarded directly via the RFIFO (RFIFO2, RFIFO3) to the system memory.

8.1.2 Transparent Mode 1

(MODE.MDS(2:0) = 101; MODE2.MDS2(2:0)=101; MODE3.MDS3(2:0)=101)

Characteristics: address recognition, flag- and CRC generation/check, bit stuffing

Only the high byte of a 2-byte address field is compared to registers RAH(2:1). The whole frame excluding the first address byte is stored in RFIFO (RFIFO2, RFIFO3).

8.1.3 Transparent Mode 0

(MODE.MDS(2:0) = 100; MODE2.MDS2(2:0)=100; MODE3.MDS3(2:0)=100)

Characteristics: flag- and CRC generation/check, bit stuffing

No address recognition is performed and each frame is stored in the RFIFO (RFIFO2, RFIFO3).

8.1.4 SS7 Support

SS7 protocol is supported for channel 1 only by means of several hardware features as described in [Chapter 4.1.14.2](#) on page 74 and [Chapter 5.1.14.2](#) on page 135.

8.1.5 Receive Data Flow

The following figure gives an overview of the management of the received HDLC frames in the different operating modes.

Signaling Controller Operating Modes

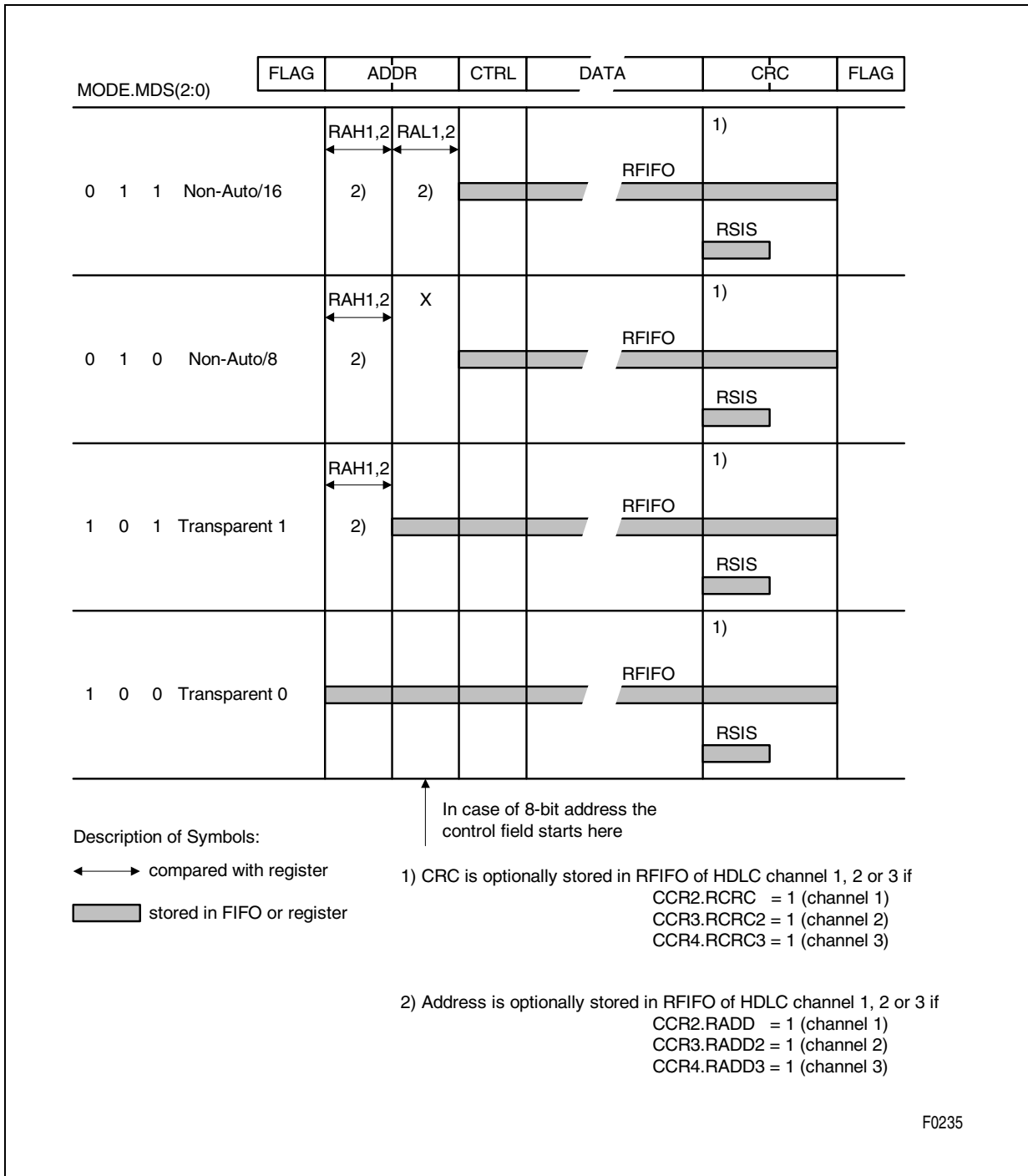

Figure 76 HDLC Receive Data Flow

8.1.6 Transmit Data Flow

The frames can be transmitted as shown below.

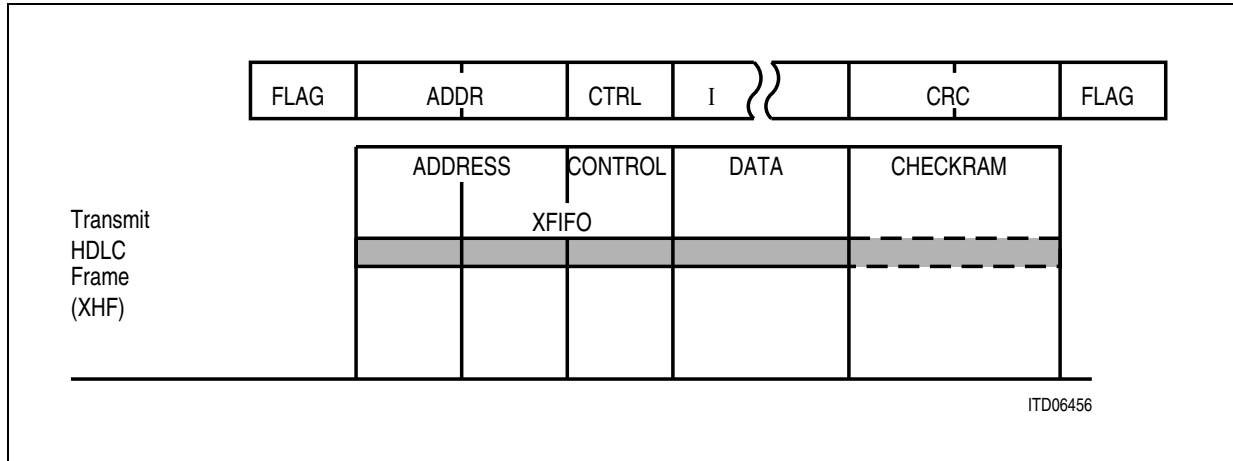

Figure 77 HDLC Transmit Data Flow

Transmitting a HDLC frame via register CMDR.XTF (or CMDR2.XTF2/CMDR3.XTF3 for channel 2/3), the address, the control fields and the data field have to be entered in the XFIFO (XFIFO2, XFIFO3).

If CCR2.XCRC (or CCR3.XCRC2/CCR4.XCRC3 for channel 2/3) is set, the CRC checksum will not be generated internally. The checksum has to be provided via the transmit FIFO (XFIFO, XFIFO2, XFIFO3) as the last two bytes. The transmitted frame is closed automatically with a closing flag only.

The FALC56 does not check whether the length of the frame, i.e. the number of bytes to be transmitted makes sense or not.

8.2 Extended Transparent Mode

Characteristics: fully transparent

In no HDLC mode, fully transparent data transmission/reception without HDLC framing is performed, i.e. without flag generation/recognition, CRC generation/check, or bit stuffing. This feature can be profitably used e.g. for:

- Specific protocol variations
- Transmission of a BOM frame (channel 1 only)
- Test purposes

Data transmission is always performed out of the XFIFO (XFIFO2, XFIFO3). In transparent mode, the receive data is shifted into the RFIFO (RFIFO2, RFIFO3).

Note: If a 1-byte frame is sent in extended transparent mode, in addition to interrupt ISR1.XPR (transmit pool ready) the interrupt ISR1.XDU (transmit buffer underrun) is set and XFIFO is blocked.

8.3 Signaling Controller Functions

8.3.1 Transparent Transmission and Reception

When programmed in the extended transparent mode via the MODE registers (MODE.MDS(2:0) = 111, MODE2.MDS2(2:0)=111, MODE3.MDS3(2:0)=111), the FALC56 performs fully transparent data transmission and reception without HDLC framing, i.e. without

- flag insertion and deletion
- CRC generation and checking
- Bit stuffing

In order to enable fully transparent data transfer, bit MODE.HRAC (MODE2.HRAC2, MODE3.HRAC3) has to be set.

Received data is always shifted into RFIFO (RFIFO2, RFIFO3).

Data transmission is always performed out of XFIFO (XFIFO2, XFIFO3) by shifting the contents of XFIFO into the outgoing data stream directly. Transmission is initiated by setting CMDR.XTF (04_H). A synchronization byte FF_H is sent automatically before the first byte of the XFIFO is transmitted.

Cyclic Transmission (fully transparent)

If the extended transparent mode is selected, the FALC56 supports the continuous transmission of the contents of the transmit FIFOs.

After having written 1 to 32 bytes to XFIFO (XFIFO2, XFIFO3), the command XREP&XTF (CMDR = 00100100 = 24_H) forces the FALC56 to transmit the data stored in XFIFO to the remote end repeatedly.

Note: The cyclic transmission continues until a reset command (CMDR.SRES) is issued or with resetting of CMDR.XREP, after which continuous "1"s are transmitted.

During cyclic transmission the XREP-bit has to be set with every write operation to CMDR.

The same handling applies to CMDR2 and CMDR3 for HDLC channels 2 and 3.

8.3.2 CRC on/off Features

As an option in HDLC mode the internal handling of the received and transmitted CRC checksum can be influenced via control bits CCR2.RCRC and CCR2.XCRC (channel 2: CCR3.RCRC2, CCR3.XCRC2, channel 3: CCR4.RCRC3, CCR4.XCRC3).

- Receive Direction

The received CRC checksum is always assumed to be in the 2 last bytes of a frame (CRC-ITU), immediately preceding a closing flag. If CCR2.RCRC is set, the received CRC checksum is written to RFIFO where it precedes the frame status byte (contents of register RSIS). The received CRC checksum is additionally checked for correctness. If

Signaling Controller Operating Modes

HDLC mode is selected, the limits for “Valid Frame” check are modified (refer to description of bit RSIS.VFR).

- Transmit Direction

If CCR2.XCRC is set, the CRC checksum is not generated internally. The checksum has to be provided via the transmit FIFO (XFIFO) as the last two bytes. The transmitted frame is closed automatically by a closing flag only.

The FALC56 does not check whether the length of the frame, i.e. the number of bytes to be transmitted is valid or not.

8.3.3 Receive Address Pushed to RFIFO

The address field of received frames can be pushed to the receive FIFOs (first one or two bytes of a frame). This function is used together with extended address recognition. It is enabled by setting control bit CCR2.RADD (CCR3.RADD2, CCR4.RADD3).

8.3.4 HDLC Data Transmission

In transmit direction 2×32 byte FIFO buffers are provided for each HDLC channel. After checking the XFIFO status by polling bit SIS.XFW (SIS2.XFW2, SIS3.XFW3) or after an interrupt ISR1.XPR (ISR5.XPR2, ISR5.XPR3, Transmit Pool Ready), up to 32 bytes can be entered by the CPU to the XFIFOs.

The transmission of a frame can be started by issuing a XTF or XHF command via the command registers. If the transmit command does not include an end of message indication (CMDR.XME, CMDR3.XME2, CMDR4.XME3), the FALC56 will repeatedly request for the next data block by means of an XPR interrupt as soon as no more than 32 bytes are stored in the XFIFO, i.e. a 32-byte pool is accessible to the CPU.

This process is repeated until the CPU indicates the end of message by XME command, after which frame transmission is finished correctly by appending the CRC and closing flag sequence. Consecutive frames can share a flag, or can be transmitted as back-to-back frames, if service of the XFIFOs is fast enough.

In case no more data is available in the XFIFOs prior to the arrival of XME, the transmission of the frame is terminated with an abort sequence and the CPU is notified by interrupt ISR1.XDU (ISR4.XDU2, ISR5.XDU3). The frame can be aborted by software using CMDR.SRES (CMDR3.SRES2, CMDR4.SRES3).

The data transmission sequence, from the CPU's point of view, is outlined in [Figure 78](#).

Signaling Controller Operating Modes

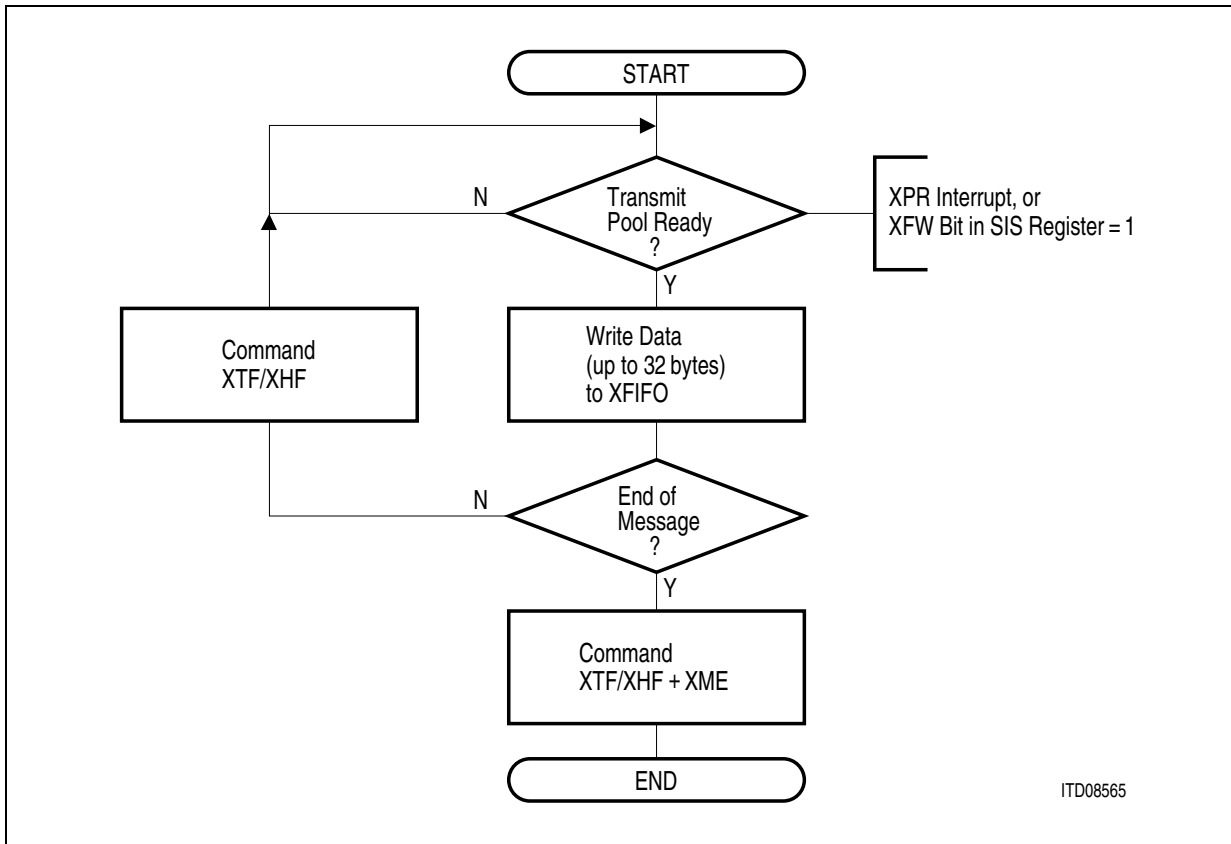

Figure 78 Interrupt Driven Data Transmission (flow diagram)

The activities at both serial and CPU interface during frame transmission (supposed frame length = 70 bytes) shown in **Figure 79**.

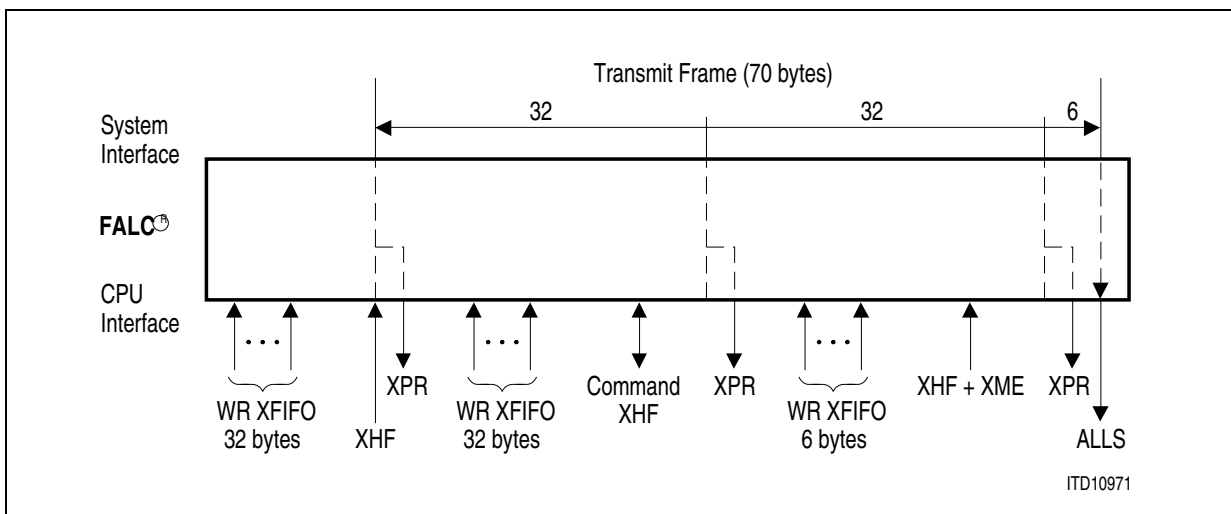

Figure 79 Interrupt Driven Transmission Example

Signaling Controller Operating Modes

8.3.5 HDLC Data Reception

2×32 byte FIFO buffers are also provided in receive direction for each HDLC channel. There are different interrupt indications concerned with the reception of data:

- RPF (RPF2, RPF3, receive pool full) interrupt, indicating that a 32-byte block of data can be read from RFIFO (RFIFO2, RFIFO3) and the received message is not yet complete.
- RME (RME2, RME3, receive message end) interrupt, indicating that the reception of one message is completed.

The following figure gives an example of a reception sequence, assuming that a “long” frame (66 bytes) followed by two short frames (6 bytes each) are received.

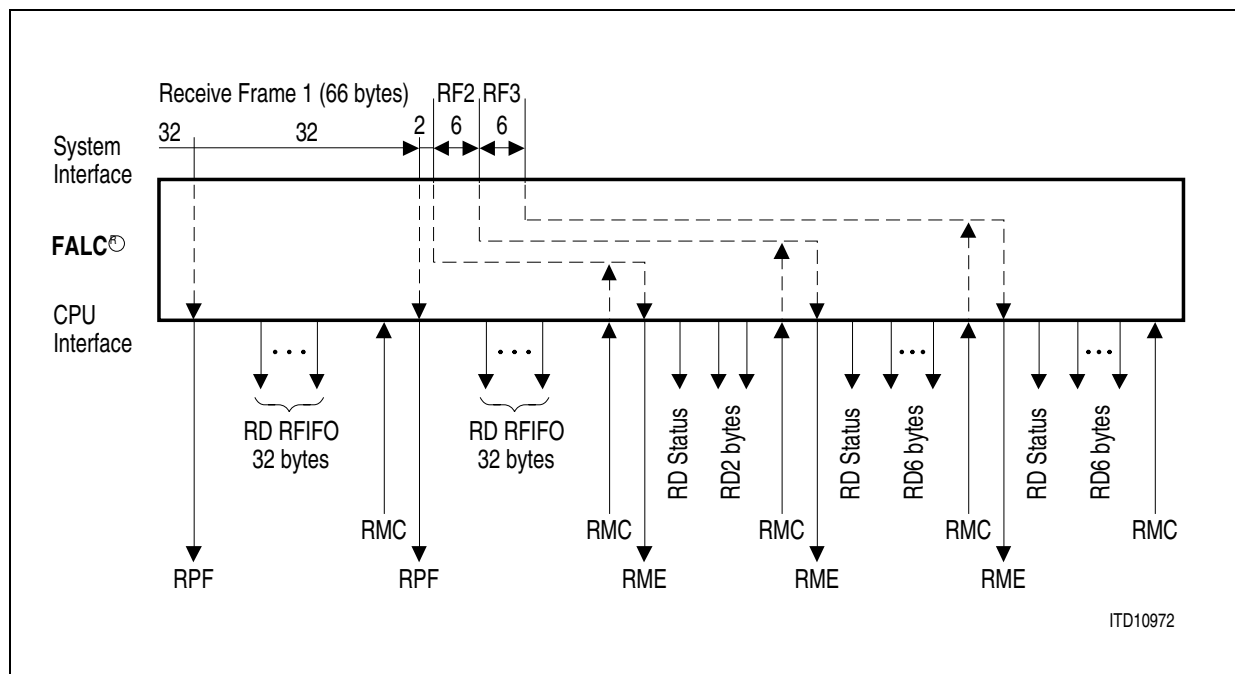

Figure 80 Interrupt Driven Reception Sequence Example

8.3.6 S_a -bit Access (E1)

The FALC56 supports the S_a -bit signaling of time slot 0 of every other frame as follows:

- Access via registers RSW/XSW
- Access via registers RSA(8:4)/XSA(8:4) capable of storing the information for a complete multiframe
- Access via the 64 byte deep receive/transmit FIFO of the integrated signaling controller (HDLC channel 1 only). This S_a -bit access gives the opportunity to transmit/receive a transparent bit stream as well as HDLC frames where the signaling controller automatically processes the HDLC protocol. Enabling is done by setting of bit CCR1.EITS and resetting of registers TTR(4:1), RTR(4:1) and FMR1.ENSA.

Signaling Controller Operating Modes

Data written to the XFIFO will be transmitted subsequently in the S_a -bit positions defined by register XC0.SA8E to SA84E and the corresponding bits of TSWM.TSA(8:4). Any combination of S_a -bits can be selected. After the data has been sent out completely an “all ones” or Flags (CCR1.ITF) is transmitted. The continuous transmission of a transparent bit stream, which is stored in the XFIFO, can be enabled.

With the setting of bit MODE.HRAC the received S_a -bits can be forwarded to the receive FIFO.

The access to and from the FIFOs is supported by ISR0.RME/RPF and ISR1.XPR/ALS.

8.3.7 Bit Oriented Message Mode (T1/J1)

The FALC56 supports signaling and maintenance functions for T1/J1 primary rate Interfaces using the Extended Super Frame format. The HDLC channel 1 of the device supports the DL-channel protocol for ESF format according to T1.403-1989 ANSI or to AT&T TR54016 specification. The HDLC and Bit Oriented Message (BOM) -Receiver can be switched on/off independently. If the FALC56 is used for HDLC formats only, the BOM receiver has to be switched off. If HDLC and BOM receiver has been switched on (MODE.HRAC/BRAC), an automatic switching between HDLC and BOM mode is enabled. Storing of received DL-bit information in the RFIFO of the signaling controller and transmitting the XFIFO contents in the DL-bit positions is enabled by CCR1.EDLX/EITS = 10. After hardware-reset (pin \overline{RES} low) or software-reset (CMDR.RRES = 1) the FALC56 operates in HDLC mode. If eight or more consecutive ones are detected, the BOM mode is entered. Upon detection of a flag in the data stream, the FALC56 switches back to HDLC mode. Operating in BOM mode, the FALC56 is able to receive an HDLC frame immediately, i.e. without any preceding flags.

In BOM mode, the following byte format is assumed (the left most bit is received first; 11111110xxxxx0).

The FALC56 uses the FF_H byte for synchronization, the next byte is stored in RFIFO (first bit received: LSB) if it starts and ends with a “0”. Bytes starting and ending with a “1” are not stored. If there are no 8 consecutive ones detected within 32 bits, an interrupt is generated. However, byte sampling is not stopped.

Signaling Controller Operating Modes

Byte sampling in BOM Mode (T1/J1)

a)

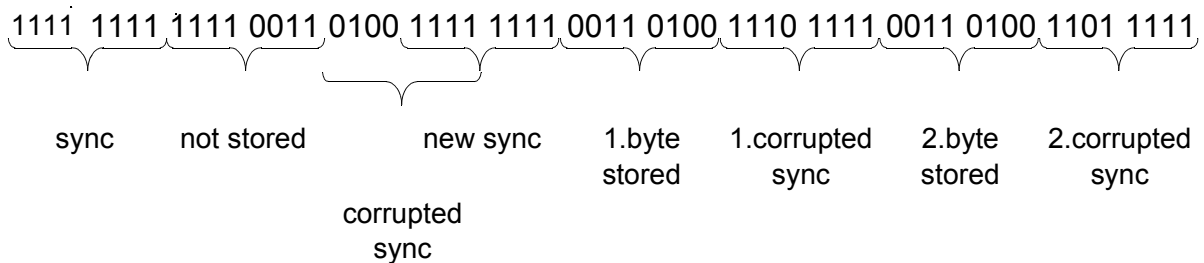

b)

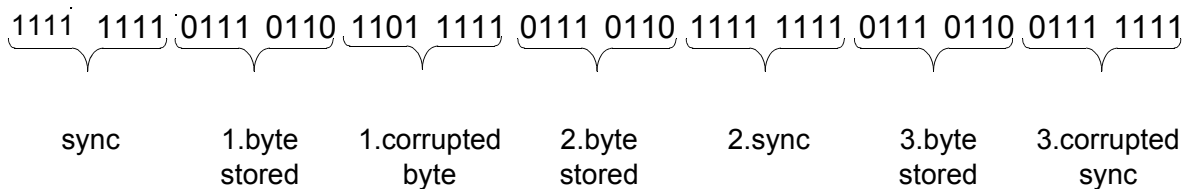

Three different BOM reception modes can be programmed (CCR1.BRM, CCR2.RBFE).

10 byte packets: CCR1.BRM = 0

After storing 10 bytes in RFIFO the receive status byte marking a BOM frame (RSIS.HFR) is added as the eleventh byte and an interrupt (ISR0.RME) is generated. The sampling of data bytes continues and interrupts are generated every 10 bytes until an HDLC flag is detected.

Continuous reception: CCR1.BRM = 1

Interrupts are generated every 32 (16, 4, 2) bytes. After detecting an HDLC flag, byte sampling is stopped, the receive status byte is stored in RFIFO and an RME interrupt is generated.

Reception with enabled BOM filter: CCR2.RBFE = 1

The BOM receiver will only accept BOM frames after detecting 7 out of 10 equal BOM pattern. The BOM pattern is stored in the RFIFO adding a receive status byte, marking a BOM frame (RSIS.HFR) and generating an interrupt status ISR0.RME. The current state of the BOM receiver is indicated in register SIS.IVB. When the valid BOM pattern disappears an interrupt ISR0.BIV is generated.

The user can switch between these modes at any time. Byte sampling can be stopped by deactivating the BOM receiver (MODE.BRAC). In this case the receive status byte is added, an interrupt is generated and HDLC mode is entered. Whether the FALC56 operates in HDLC or BOM mode are checked by reading the signaling status register (SIS.BOM).

8.3.8 Data Link Access in ESF/F72 Format (T1/J1)

The FALC56 supports the DL-channel protocol using the ESF or F72 (SLC96) format as follows (HDLC channel 1 only):

- Sampling of DL-bits is done on a multiframe basis and stored in the registers RDL(3:1). A receive multiframe begin interrupt is provided to read the received data DL-bits. The contents of registers XDL(3:1) is subsequently sent out on the transmit multiframe basis if it is enabled via FMR1.EDL. A transmit multiframe begin interrupt requests for writing new information to the DL-bit registers.
- If enabled via CCR1.EDLX/EITS = 10, the DL-bit information is stored in the receive FIFO of the signaling controller. The DL-bits stored in the XFIFO are inserted into the outgoing data stream. If CCR1.EDLX is cleared, a HDLC frame or a transparent frame can be sent or received via the RFIFO/XFIFO.

Register Description

Due to the different device function in E1 and T1/J1 mode, several registers and register bits have dedicated functions according to the selected operation mode.

To maintain easy readability this chapter is divided into separate E1 and T1/J1 sections. Please choose the correct description according to your application (E1 or T1/J1).

9 E1 Registers

9.1 E1 Control Register Addresses

Table 58 E1 Control Register Address Arrangement

Address	Register	Type	Comment	Page
00	XFIFO	W	Transmit FIFO	217
01	XFIFO	W	Transmit FIFO	217
02	CMDR	W	Command Register	217
03	MODE	R/W	Mode Register	219
04	RAH1	R/W	Receive Address High 1	220
05	RAH2	R/W	Receive Address High 2	220
06	RAL1	R/W	Receive Address Low 1	220
07	RAL2	R/W	Receive Address Low 2	220
08	IPC	R/W	Interrupt Port Configuration	221
09	CCR1	R/W	Common Configuration Register 1	221
0A	CCR2	R/W	Common Configuration Register 2	224
0C	RTR1	R/W	Receive Time Slot Register 1	225
0D	RTR2	R/W	Receive Time Slot Register 2	225
0E	RTR3	R/W	Receive Time Slot Register 3	225
0F	RTR4	R/W	Receive Time Slot Register 4	225
10	TTR1	R/W	Transmit Time Slot Register 1	226
11	TTR2	R/W	Transmit Time Slot Register 2	226
12	TTR3	R/W	Transmit Time Slot Register 3	226
13	TTR4	R/W	Transmit Time Slot Register 4	226
14	IMR0	R/W	Interrupt Mask Register 0	227
15	IMR1	R/W	Interrupt Mask Register 1	227
16	IMR2	R/W	Interrupt Mask Register 2	227
17	IMR3	R/W	Interrupt Mask Register 3	227
18	IMR4	R/W	Interrupt Mask Register 4	227
19	IMR5	R/W	Interrupt Mask Register 5	227
1B	IERR	R/W	Single Bit Error Insertion Register	227
1C	FMR0	R/W	Framer Mode Register 0	228

Table 58 E1 Control Register Address Arrangement (cont'd)

Address	Register	Type	Comment	Page
1D	FMR1	R/W	Framer Mode Register 1	230
1E	FMR2	R/W	Framer Mode Register 2	232
1F	LOOP	R/W	Channel Loop-Back	233
20	XSW	R/W	Transmit Service Word	234
21	XSP	R/W	Transmit Spare Bits	235
22	XC0	R/W	Transmit Control 0	236
23	XC1	R/W	Transmit Control 1	237
24	RC0	R/W	Receive Control 0	238
25	RC1	R/W	Receive Control 1	239
26	XPM0	R/W	Transmit Pulse Mask 0	241
27	XPM1	R/W	Transmit Pulse Mask 1	241
28	XPM2	R/W	Transmit Pulse Mask 2	241
29	TSWM	R/W	Transparent Service Word Mask	242
2B	IDLE	R/W	Idle Channel Code	243
2C	XSA4	R/W	Transmit S _a 4-Bit Register	244
2D	XSA5	R/W	Transmit S _a 5-Bit Register	244
2E	XSA6	R/W	Transmit S _a 6-Bit Register	244
2F	XSA7	R/W	Transmit S _a 7-Bit Register	244
30	XSA8	R/W	Transmit S _a 8-Bit Register	244
31	FMR3	R/W	Framer Mode Register 3	245
32	ICB1	R/W	Idle Channel Register 1	246
33	ICB2	R/W	Idle Channel Register 2	246
34	ICB3	R/W	Idle Channel Register 3	246
35	ICB4	R/W	Idle Channel Register 4	246
36	LIM0	R/W	Line Interface Mode 0	247
37	LIM1	R/W	Line Interface Mode 1	248
38	PCD	R/W	Pulse Count Detection	249
39	PCR	R/W	Pulse Count Recovery	250
3A	LIM2	R/W	Line Interface Mode 2	250
3B	LCR1	R/W	Loop Code Register 1	251

Table 58 E1 Control Register Address Arrangement (cont'd)

Address	Register	Type	Comment	Page
3C	LCR2	R/W	Loop Code Register 2	253
3D	LCR3	R/W	Loop Code Register 3	253
3E	SIC1	R/W	System Interface Control 1	254
3F	SIC2	R/W	System Interface Control 2	255
40	SIC3	R/W	System Interface Control 3	256
44	CMR1	R/W	Clock Mode Register 1	258
45	CMR2	R/W	Clock Mode Register 2	259
46	GCR	R/W	Global Configuration Register	261
47	ESM	R/W	Errored Second Mask	262
60	DEC	W	Disable Error Counter	262
70	XS1	W	Transmit CAS Register 1	263
71	XS2	W	Transmit CAS Register 2	263
72	XS3	W	Transmit CAS Register 3	263
73	XS4	W	Transmit CAS Register 4	263
74	XS5	W	Transmit CAS Register 5	263
75	XS6	W	Transmit CAS Register 6	263
76	XS7	W	Transmit CAS Register 7	263
77	XS8	W	Transmit CAS Register 8	263
78	XS9	W	Transmit CAS Register 9	263
79	XS10	W	Transmit CAS Register 10	263
7A	XS11	W	Transmit CAS Register 11	263
7B	XS12	W	Transmit CAS Register 12	263
7C	XS13	W	Transmit CAS Register 13	263
7D	XS14	W	Transmit CAS Register 14	263
7E	XS15	W	Transmit CAS Register 15	263
7F	XS16	W	Transmit CAS Register 16	263
80	PC1	R/W	Port Configuration 1	264
81	PC2	R/W	Port Configuration 2	264
82	PC3	R/W	Port Configuration 3	264
83	PC4	R/W	Port Configuration 4	264

Table 58 E1 Control Register Address Arrangement (cont'd)

Address	Register	Type	Comment	Page
84	PC5	R/W	Port Configuration 5	266
85	GPC1	R/W	Global Port Configuration 1	267
86	PC6	R/W	Port Configuration 6	268
87	CMDR2	W	Command Register 2	269
88	CMDR3	W	Command Register 3	269
89	CMDR4	W	Command Register 4	270
8B	CCR3	R/W	Common Control Register 3	271
8C	CCR4	R/W	Common Control Register 4	273
8D	CCR5	R/W	Common Control Register 5	274
8E	MODE2	R/W	Mode Register 2	275
8F	MODE3	R/W	Mode Register 3	276
92	GCM1	R/W	Global Counter Mode 1	277
93	GCM2	R/W	Global Counter Mode 2	277
94	GCM3	R/W	Global Counter Mode 3	278
95	GCM4	R/W	Global Counter Mode 4	278
96	GCM5	R/W	Global Counter Mode 5	279
97	GCM6	R/W	Global Counter Mode 6	279
9C	XFIFO2	W	Transmit FIFO 2	281
9D	XFIFO2	W	Transmit FIFO 2	281
9E	XFIFO3	W	Transmit FIFO 3	281
9F	XFIFO3	W	Transmit FIFO 3	281
A0	TSEO	R/W	Time Slot Even/Odd Select	281
A1	TSBS1	R/W	Time Slot Bit Select 1	282
A2	TSBS2	R/W	Time Slot Bit Select 2	283
A3	TSBS3	R/W	Time Slot Bit Select 3	283
A4	TSS2	R/W	Time Slot Select 2	284
A5	TSS3	R/W	Time Slot Select 3	284
A8	TPC0	R/W	Test Pattern Control Register 0	285

After reset all control registers except the XFIFO and XS(16:1) are initialized to defined values. Unused bits have to be cleared (logical "0").

9.2 Detailed Description of E1 Control Registers

Transmit FIFO - HDLC Channel 1 (Write)

	7		0	
XFIFO	XF7		XF0	(00)
XFIFO	XF15		XF8	(01)

Writing data to XFIFO of HDLC channel 1 can be done in 8-bit (byte) or 16-bit (word) access. The LSB is transmitted first.

Up to 32 bytes/16 words of transmit data can be written to the XFIFO following a XPR interrupt.

Command Register (Write)

Value after reset: 00_H

	7		0						
CMDR	RMC	RRES	XREP	XRES	XHF	XTF	XME	SRES	(02)

RMC **Receive Message Complete - HDLC Channel 1**

Confirmation from CPU to FALC56 that the current frame or data block has been fetched following a RPF or RME interrupt, thus the occupied space in the RFIFO can be released. If RMC is given while RFIFO is already cleared, the next incoming data block is cleared instantly, although interrupts are generated.

RRES **Receiver Reset**

The receive line interface except the clock and data recovery unit (DPLL), the receive framer, the one-second timer and the receive signaling controller are reset. However the contents of the control registers is not deleted.

XREP **Transmission Repeat - HDLC Channel 1**

If XREP is set together with XTF (write 24_H to CMDR), the FALC56 repeatedly transmits the contents of the XFIFO (1 to 32 bytes) without HDLC framing fully transparently, i.e. without flag, CRC.

The cyclic transmission is stopped with a SRES command or by resetting XREP.

Note: During cyclic transmission the XREP-bit has to be set with every write operation to CMDR.

XRES	Transmitter Reset The transmit framer and transmit line interface excluding the system clock generator and the pulse shaper are reset. However the contents of the control registers is not deleted.
XHF	Transmit HDLC Frame - HDLC Channel 1 After having written up to 32 bytes to the XFIFO, this command initiates the transmission of a HDLC frame.
XTF	Transmit Transparent Frame - HDLC Channel 1 Initiates the transmission of a transparent frame without HDLC framing.
XME	Transmit Message End - HDLC Channel 1 Indicates that the data block written last to the transmit FIFO completes the current frame. The FALC56 can terminate the transmission operation properly by appending the CRC and the closing flag sequence to the data.
SRES	Signaling Transmitter Reset - HDLC Channel 1 The transmitter of the signaling controller is reset. XFIFO is cleared of any data and an abort sequence (seven 1's) followed by interframe time fill is transmitted. In response to SRES a XPR interrupt is generated. This command can be used by the CPU to abort a frame currently in transmission. Note: The maximum time between writing to the CMDR register and the execution of the command takes 2.5 periods of the current system data rate. Therefore, if the CPU operates with a very high clock rate in comparison with the FALC56's clock, it is recommended that bit SIS.CEC should be checked before writing to the CMDR register to avoid any loss of commands. Note: If SCLKX is used to clock the transmission path, commands to the HDLC transmitter should only be sent while this clock is available. If SCLKX is missing, the command register is blocked after an HDLC command is given.

Mode Register (Read/Write)

Value after reset: 00_H

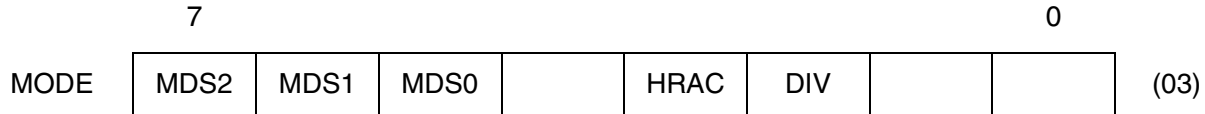

MDS(2:0)

Mode Select - HDLC Channel 1

The operating mode of the HDLC controller is selected.

000 = Reserved

001 = Signaling System 7 (SS7) support¹⁾

010 = One-byte address comparison mode (RAL1,2)

011 = Two-byte address comparison mode (RAH1,2 and RAL1,2)

100 = No address comparison

101 = One-byte address comparison mode (RAH1,2)

110 = Reserved

111 = No HDLC framing mode

HRAC

Receiver Active - HDLC Channel 1

Switches the HDLC receiver to operational or inoperational state.

0 = Receiver inactive

1 = Receiver active

DIV

Data Inversion - HDLC Channel 1

Setting this bit inverts the internal generated HDLC channel 1 data stream.

0 = Normal operation, HDLC data stream not inverted

1 = HDLC data stream inverted

¹⁾ CCR2.RADD must be set, if SS7 mode is selected

Receive Address Byte High Register 1 (Read/Write)

Value after reset: FD_H

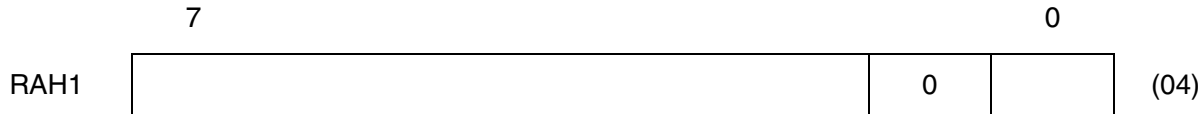

In operating modes that provide high byte address recognition, the high byte of the received address is compared to the individually programmable values in RAH1 and RAH2. The address registers are used by all HDLC channels in common.

RAH1 Value of the First Individual High Address Byte

Bit 1 (C/R-bit) is excluded from address comparison.

Receive Address Byte High Register 2 (Read/Write)

Value after reset: FF_H

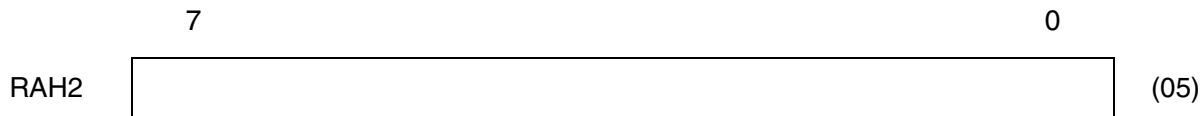

RAH2 Value of Second Individual High Address Byte

Receive Address Byte Low Register 1 (Read/Write)

Value after reset: FF_H

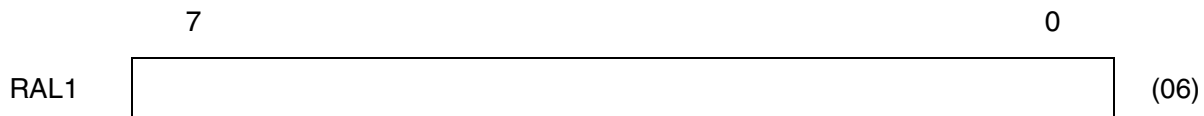

RAL1 Value of First Individual Low Address Byte

Receive Address Byte Low Register 2 (Read/Write)

Value after reset: FF_H

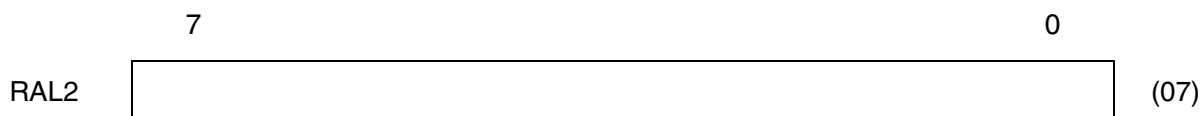

RAL2 Value of the second individually programmable low address byte.

Interrupt Port Configuration (Read/Write)

Value after reset: 00_H

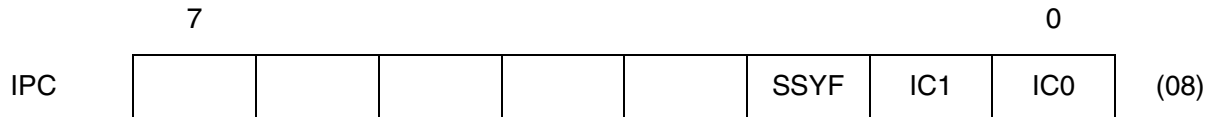

Note: Unused bits have to be cleared.

SSYF Select SYNC Frequency

Only applicable in master mode (LIM0.MAS = 1) and bit CMR2.DCF is cleared.

- 0 = Reference clock on port SYNC is 2.048 MHz
- 1 = Reference clock on port SYNC is 8 kHz

IC0, IC1 Interrupt Port Configuration

These bits define the function of the interrupt output stage (pin INT):

IC1	IC0	Function
X	0	Open drain output
0	1	Push/pull output, active low
1	1	Push/pull output, active high

Common Configuration Register 1 (Read/Write)

Value after reset: 00_H

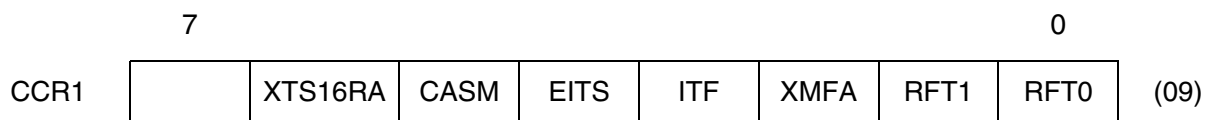

XTS16RA Send Remote Alarm in Time Slot 16

Sending of remote alarm in time slot 16 towards remote end by setting bit "Y" in the CAS multiframe alignment word. If XS registers are used for CAS (instead of XSIG), bit XS1.2 ("Y") is logically ored with XTS16RA. If XSIG is used for CAS, Y-data received on XSIG is logically ored with XTS16RA.

- 0 = No remote alarm insertion
- 1 = Remote alarm insertion

CASM CAS Synchronization Mode

Determines the synchronization mode of the channel associated signaling multiframe alignment.

- 0 = Synchronization is done in accordance to ITU-T G. 732
- 1 = Synchronization is established when two consecutively correct multiframe alignment pattern are found.

EITS**Enable Internal Time Slot 0 to 31 Signaling**

- 0 = Internal signaling in time slots 0 to 31 defined by registers RTR(4:1) or TTR(4:1) is disabled.
- 1 = Internal signaling in time slots 0 to 31 defined by registers RTR(4:1) or TTR(4:1) is enabled.

ITF**Interframe Time Fill**

Determines the idle (= no data to be sent) state of the transmit data coming from the signaling controller.

- 0 = Continuous logical "1" is output
- 1 = Continuous flag sequences are output ("01111110" bit patterns)

XMFA**Transmit Multiframe Aligned**

Determines the synchronization between the framer and the corresponding signaling controller.

- 0 = The contents of the XFIFO is transmitted without multiframe alignment.
- 1 = The contents of the XFIFO is transmitted multiframe aligned. The first byte in XFIFO is transmitted in the first time slot selected by TTR(4:1) and so on. After reception of a complete multiframe in the time slot mode (RTR(4:1)) an ISR0.RME interrupt is generated, if no HDLC mode is enabled
In S_a -bit access mode XMFA is not valid.

Note: During the transmission of the XFIFO content, the \overline{SYPX} or XMFS interval time should not be changed, otherwise the XFIFO data has to be retransmitted.

RFT(1:0)

RFIFO Threshold Level - HDLC Channel 1

The size of the accessible part of RFIFO can be determined by programming these bits. The number of valid bytes after a RPF interrupt is given in the following table:

RFT1	RFT0	Size of Accessible Part of RFIFO
0	0	32 bytes (reset value)
0	1	16 bytes
1	0	4 bytes
1	1	2 bytes

The value of RFT1, 0 can be changed dynamically.

- If reception is not running or
- after the current data block has been read, but before the command CMDR.RMC is issued (interrupt controlled data transfer).

Note: It is seen that changing the value of RFT1, 0 is possible even during the reception of one frame. The total length of the received frame can be always read directly in RBCL, RBCH after a RPF interrupt, except when the threshold is increased during reception of that frame. The real length can then be inferred by noting which bit positions in RBCL are reset by a RMC command (see table below):

RFT1	RFT0	Bit Positions in RBCL Reset by a CMDR.RMC Command
0	0	RBC(4:0)
0	1	RBC(3:0)
1	0	RBC(1:0)
1	1	RBC0

Common Configuration Register 2 (Read/Write)

Value after reset: 00_H

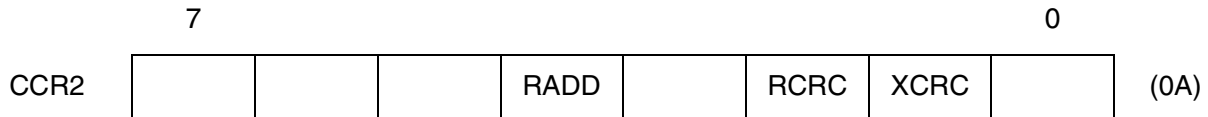

Note: Unused bits have to be cleared.

RADD Receive Address Pushed to RFIFO - HDLC Channel 1
 If this bit is set, the received HDLC address information (1 or 2 bytes, depending on the address mode selected by MODE.MDS0) is pushed to RFIFO. This function is applicable in non-auto mode and transparent mode 1.

RADD must be set, if SS7 mode is selected.

RCRC Receive CRC on/off - HDLC Channel 1
 Only applicable in non-auto mode.
 If this bit is set, the received CRC checksum is written to RFIFO (CRC-ITU-T: 2 bytes). The checksum, consisting of the 2 last bytes in the received frame, is followed by the status information byte (contents of register RSIS). The received CRC checksum is additionally checked for correctness. If non-auto mode is selected, the limits for “valid frame” check are modified (refer to RSIS.VFR).

XCRC Transmit CRC on/off - HDLC Channel 1
 If this bit is set, the CRC checksum is not generated internally. It has to be written to the transmit FIFO as the last two bytes. The transmitted frame is closed automatically with a closing flag.

Note: The FALC56 does not check whether the length of the frame, i.e. the number of bytes to be transmitted makes sense or not.

Receive Time Slot Register 1 to 4 (Read/Write)

Value after reset: 00_H, 00_H, 00_H, 00_H

	7							0	
RTR1	TS0	TS1	TS2	TS3	TS4	TS5	TS6	TS7	(0C)
RTR2	TS8	TS9	TS10	TS11	TS12	TS13	TS14	TS15	(0D)
RTR3	TS16	TS17	TS18	TS19	TS20	TS21	TS22	TS23	(0E)
RTR4	TS24	TS25	TS26	TS27	TS28	TS29	TS30	TS31	(0F)

TS(31:0)

Time Slot

These bits define the received time slots on the system highway port RDO to be extracted to RFIFO and marked. Additionally these registers control the RSGM marker which can be forced high during the corresponding time slots independently of bit CCR1.EITS.

A one in the RTR(4:1) bits samples the corresponding time slots and send their data to the RFIFO of the signaling controller if bit CCR1.EITS is set.

Assignments:

TS0 → Time slot 0

...

TS31 → Time slot 31

0 = The corresponding time slot is not extracted and stored into the RFIFO.

1 = The contents of the selected time slot is stored in the RFIFO. Although the idle time slots can be selected. This function is activated, if bit CCR1.EITS is set.

The corresponding time slot is forced high on marker pin RSGM.

Transmit Time Slot Register 1 to 4 (Read/Write)

Value after reset: 00_H, 00_H, 00_H, 00_H

	7							0	
TTR1	TS0	TS1	TS2	TS3	TS4	TS5	TS6	TS7	(10)
TTR2	TS8	TS9	TS10	TS11	TS12	TS13	TS14	TS15	(11)
TTR3	TS16	TS17	TS18	TS19	TS20	TS21	TS22	TS23	(12)
TTR4	TS24	TS25	TS26	TS27	TS28	TS29	TS30	TS31	(13)

TS(31:0)

Time Slot

These bits define the transmit time slots on the system highway to be inserted. Additionally these registers control the XSIGM marker which can be forced high during the corresponding time slots independently of bit CCR1.EITS.

A one in the TTR(4:1) bits inserts the corresponding time slot sourced by the XFIFO in the data received on pin XDI, if bit CCR1.EITS is set. If SIC3.TTRF is set and CCR1.EITS is cleared insertion of data received on port XSIG is controlled by this registers.

Assignments:

TS0 → Time slot 0

...

TS31 → Time slot 31

0 = The selected time slot is not inserted into the outgoing data stream.

1 = The contents of the selected time slot is inserted into the outgoing data stream from XFIFO. This function is active only if bit CCR1.EITS is set.

The corresponding time slot is forced high on marker pin XSIGM.

Interrupt Mask Register 0 to 5 (Read/Write)

Value after reset: FF_H, FF_H, FF_H, FF_H, FF_H

	7							0	
IMR0	RME	RFS	T8MS	RMB	CASC	CRC4	SA6SC	RPF	(14)
IMR1	LLBSC	RDO	ALLS	XDU	XMB	SUEX	XLSC	XPR	(15)
IMR2	FAR	LFA	MFAR	T400MS	AIS	LOS	RAR	RA	(16)
IMR3	ES	SEC	LMFA16	AIS16	RA16		RSN	RSP	(17)
IMR4	XSP	XSN	RME2	RFS2	RDO2	ALLS2	XDU2	RPF2	(18)
IMR5	XPR2	XPR3	RME3	RFS3	RDO3	ALLS3	XDU3	RPF3	(19)

IMR(5:0) Interrupt Mask Register

Each interrupt source can generate an interrupt signal on port INT (characteristics of the output stage are defined by register IPC). A “1” in a bit position of IMR(5:0) sets the mask active for the interrupt status in ISR(5:0). Masked interrupt statuses neither generate a signal on INT, nor are they visible in register GIS. Moreover, they are

- not displayed in the interrupt status register if bit GCR.VIS is cleared
- displayed in the interrupt status register if bit GCR.VIS is set

Note: After reset, all interrupts are **disabled**.

Single Bit Defect Insertion Register (Read/Write)

Value after reset: 00_H

IERR			IFASE	IMFE	ICRCE	ICASE	IPE	IBV	(1B)
------	--	--	-------	------	-------	-------	-----	-----	------

After setting the corresponding bit, the selected defect is inserted into the transmit data stream at the next possible position. After defect insertion is completed, the bit is reset automatically.

- IFASE** **Insert single FAS defect**
- IMFE** **Insert single multiframe defect**
- ICRCE** **Insert single CRC defect**
- ICASE** **Insert single CAS defect**
- IPE** **Insert single PRBS defect**

IBV Insert bipolar violation

Note: Except for CRC defects, CRC checksum calculation is done after defect insertion.

Framer Mode Register 0 (Read/Write)

Value after reset: 00_H

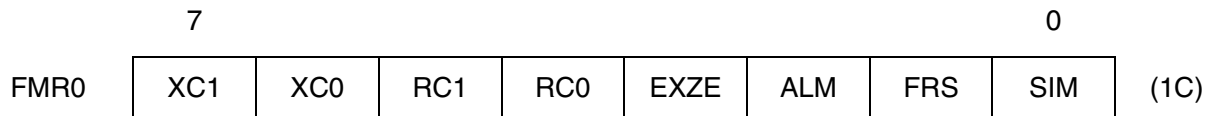

XC(1:0) Transmit Code

Serial line code for the transmitter, independent of the receiver.

00 = NRZ (optical interface)

01 = CMI (1T2B+HDB3), (optical interface)

10 = AMI (ternary or digital dual-rail interface)

11 = HDB3 Code (ternary or digital dual-rail interface)

After changing XC(1:0), a transmitter software reset is required (CMDR.XRES = 1).

RC(1:0) Receive Code

Serial line code for the receiver, independent of the transmitter.

00 = NRZ (optical interface)

01 = CMI (1T2B+HDB3), (optical interface)

10 = AMI (ternary or digital dual-rail interface)

11 = HDB3 Code (ternary or digital dual-rail interface)

After changing RC(1:0), a receiver software reset is required (CMDR.RRES = 1).

EXZE Extended HDB3 Error Detection

Selects error detection mode.

0 = Only double violations are detected.

1 = Extended code violation detection: 0000 strings are detected additionally. Incrementing of the code violation counter CVC is done after receiving four zeros. Errors are indicated by FRS1.EXZD = 1.

ALM Alarm Mode

Selects the AIS alarm detection mode.

E1 Registers

- 0 = The AIS alarm is detected according to ETS300233.
Detection: An AIS alarm is detected if the incoming data stream contains less than 3 zeros within a period of 512 bits and a loss of frame alignment is indicated.
Recovery: The alarm is cleared if 3 or more zeros within 512 bits are detected or the FAS word is found.
- 1 = The AIS alarm is detected according to ITU-T G.775
Detection: An AIS alarm is detected if the incoming data stream contains less than 3 zeros in each doubleframe period of two consecutive doubleframe periods (1024 bits).
Recovery: The alarm is cleared if 3 or more zeros are detected within two consecutive doubleframe periods.

FRS

Force Resynchronization

A transition from low to high initiates a resynchronization procedure of the pulse frame and the CRC-multiframe (if enabled by bit FMR2.RFS1) starting directly after the old framing candidate.

SIM

Alarm Simulation

- 0 = Normal operation.
- 1 = Initiates internal error simulation of AIS, loss-of-signal, loss of synchronization, remote alarm, slip, framing errors, CRC errors, and code violations. The error counters FEC, CVC, CEC1 are incremented.

SIM has to be held stable at high or low level for at least one receive clock period before changing it again.

Framer Mode Register 1 (Read/Write)

Value after reset: 00_H

	7							0	
FMR1	MFCS	AFR	ENSA	PMOD	XFS	ECM	SSD0	XAIS	(1D)

MFCS

Multiframe Force Resynchronization

Only valid if CRC multiframe format is selected (FMR2.RFS(1:0) = 10).

A transition from low to high initiates the resynchronization procedure for CRC-multiframe alignment without influencing doubleframe synchronous state. In case, “Automatic Force Resynchronization” (FMR1.AFR) is enabled and multiframe alignment cannot be regained, a new search of doubleframe (and CRC multiframe) is automatically initiated.

AFR

Automatic Force Resynchronization

Only valid if CRC multiframe format is selected (FMR2.RFS(1:0) = 10).

If this bit is set, a search of doubleframe alignment is automatically initiated if two multiframe patterns with a distance of $n \times 2$ ms have not been found within a time interval of 8 ms after doubleframe alignment has been regained or command FMR1.MFCS has been issued.

ENSA

Enable S_a-Bit Access through Register XSA4-8

Only applicable if FMR1.XFS is set.

0 = Normal operation. The S_a-bit information is taken from bits XSW.XY(4:0) and written to bits RSW.RY(4:0).

1 = S_a-bit register access. The S_a-bit information is taken from the registers XSA(8:4). In addition, the received information is written to registers RSA(8:4). Transmitting of the contents of registers XSA(8:4) is disabled if one of time slot 0 transparent modes is enabled (XSP.TT0 or TSWM.SA(8:4)).

PMOD

PCM Mode

For E1 application this bit must be set low. Switching from E1 to T1 or vice versa the device needs up to 20 μs to settle up to the internal clocking.

0 = PCM 30 or E1 mode.

1 = PCM 24 or T1/J1 mode (see RC0.SJR for T1/J1 selection).

XFS

Transmit Framing Select

Selection of the transmit framing format can be done independently of the receive framing format.

0 = Doubleframe format enabled.

1 = CRC4-multiframe format enabled.

ECM

Error Counter Mode

The function of the error counters is determined by this bit.

0 = Before reading an error counter the corresponding bit in the Disable Error Counter register (DEC) has to be set. In 8 bit access the low byte of the error counter should always be read before the high byte. The error counters are reset with the rising edge of the corresponding bits in the DEC register.

1 = Every second the error counter is latched and then automatically reset. The latched error counter state should be read within the next second. Reading the error counter during updating should be avoided (do not access an error counter within 1 μ s after the one-second interrupt occurs).

SSD0

Select System Data Rate 0

FMR1.SSD0 and SIC1.SSD1 define the data rate on the system highway. Programming is done with SSD1/SSD0 in the following table.

00 = 2.048 Mbit/s

01 = 4.096 Mbit/s

10 = 8.192 Mbit/s

11 = 16.384 Mbit/s

XAIS

Transmit AIS Towards Remote End

Sends AIS on ports XL1, XL2, XOID towards the remote end. The outgoing data stream which can be looped back through the local loop to the system interface is not affected.

Framer Mode Register 2 (Read/Write)

Value after reset: 00_H

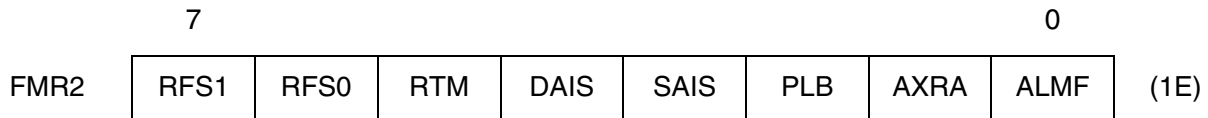

RFS(1:0) Receive Framing Select

00 = Doubleframe format
 01 = Doubleframe format
 10 = CRC4 Multiframe format
 11 = CRC4 Multiframe format with modified CRC4 Multiframe alignment algorithm (Interworking according to ITU-T G.706 Annex B). Setting of FMR3.EXTIW changes the reaction after the 400 ms time-out.

RTM Receive Transparent Mode

Setting this bit disconnects control of the internal elastic store from the receiver. The elastic store is now in a “free running” mode without any possibility to actualize the time slot assignment to a new frame position in case of resynchronization of the receiver. This function can be used together with the “disable AIS to system interface” feature (FMR2.DAIS) to realize undisturbed transparent reception. This bit should be enabled in case of unframed data reception mode.

DAIS Disable AIS to System Interface

0 = AIS is automatically inserted into the data stream to RDO if FALC56 is in asynchronous state.
 1 = Automatic AIS insertion is disabled. Furthermore, AIS insertion can be initiated by programming bit FMR2.SAIS.

SAIS Send AIS Towards System Interface

Sends AIS on output RDO towards system interface. This function is not influenced by bit FMR2.DAIS.

PLB Payload Loop-Back

0 = Normal operation. Payload loop is disabled.
 1 = The payload loop-back loops the data stream from the receiver section back to transmitter section. Looped data is output on pin RDO. Data received on port XDI, XSIG, SYPX and XMFS is ignored. With XSP.TT0 = 1 time slot 0 is also looped back. If XSP.TT0 = 0 time slot 0 is generated internally. AIS is sent

immediately on port RDO by setting the FMR2.SAIS bit. It is recommended to write the actual value of XC1 into this register once again, because a write access to register XC1 sets the read/write pointer of the transmit elastic buffer into its optimal position to ensure a maximum wander compensation (the write operation forces a slip).

AXRA Automatic Transmit Remote Alarm

- 0 = Normal operation
- 1 = The remote alarm bit is set automatically in the outgoing data stream if the receiver is in asynchronous state (FRS0.LFA bit is set). In synchronous state the remote alarm bit is reset. Additionally in multiframe format FMR2.RFS1 = 1 and FMR3.EXTIW = 1 and the 400 ms time-out has elapsed, the remote alarm bit is active in the outgoing data stream. In multiframe synchronous state the outgoing remote alarm bit is cleared.

ALMF Automatic Loss of Multiframe

- 0 = Normal operation
- 1 = The receiver searches a new basic- and multiframe if more than 914 CRC errors have been detected in a time interval of one second. The internal 914 CRC error counter is reset if the multiframe synchronization is found. Incrementing the counter is only enabled in the multiframe synchronous state.

Channel Loop-Back (Read/Write)

Value after reset: 00_H

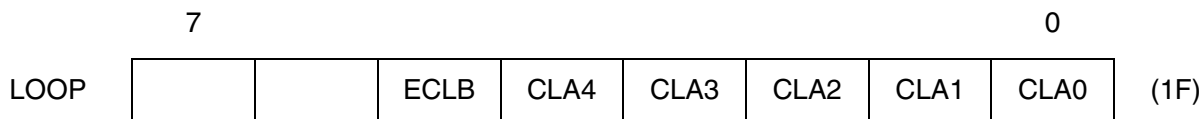

ECLB Enable Channel Loop-Back

- 0 = Disables the channel loop-back.
- 1 = Enables the channel loop-back selected by this register.

CLA(4:0) Channel Address For Loop-Back

CLA = 0 to 31 selects the channel.
During looped back the contents of the assigned outgoing channel on ports XL1/XDOP/XOID and XL2/XDON is equal to the idle channel code programmed at register IDLE.

Transmit Service Word Pulseframe (Read/Write)

Value after reset: 00_H

	7						0		
XSW	X S I S	X T M	X R A	X Y 0	X Y 1	X Y 2	X Y 3	X Y 4	(20)

X SIS

Spare Bit For International Use

First bit of the service word. Only significant in doubleframe format. If not used, this bit should be fixed to "1". If one of the time slot 0 transparent modes is enabled (bit XSP.TT0, or TSWM.TSIS), bit XSW.XSIS is ignored.

X TM

Transmit Transparent Mode

0 = Ports $\overline{\text{SYPX}}$ /XMFS define the frame/multiframe begin on the transmit system highway. The transmitter is usually synchronized on this externally sourced frame boundary and generates the FAS-bits according to this framing. Any change of the transmit time slot assignment subsequently produces a change of the FAS-bit positions.

1 = Disconnects the control of the transmit system interface from the transmitter. The transmitter is now in a free running mode without any possibility to actualize the multiframe position. The framing (FAS-bits) generated by the transmitter is not "disturbed" (in case of changing the transmit time slot assignment) by the transmit system highway unless register XC1 is written. Useful in loop-timed applications. For proper operation the transmit elastic buffer (2 frames, SIC1.XBS(1:0) = 10) has to be enabled.

X RA

Transmit Remote Alarm

0 = Normal operation.
1 = Sends remote alarm towards remote end by setting bit 3 of the service word. If time slot 0 transparent mode is enabled by bit XSP.TT0 or TSWM.TRA bit is set, bit XSW.XRA is ignored.

XY(4:0)

Spare Bits For National Use (Y-Bits, S_n-Bits, S_a-Bits)

These bits are inserted in the service word of every other pulseframe if S_a-bit register access is disabled (FMR1.ENSA = 0). If not used, they should be fixed to "1".

If one of the time slot 0 transparent modes is enabled (bit XSP.TT0 or TSWM.TSA(8:4)), bits XSW.XY(4:0) are ignored.

Transmit Spare Bits (Read/Write)

Value after reset: 00_H

	7						0		
XSP		CASEN	TT0	EBP	AXS	XSIF	XS13	XS15	(21)

CASEN **Channel Associated Signaling Enable**
 0 = Normal operation.
 1 = A one in this bit position causes the transmitter to send the CAS information stored in the XS(16:1) registers or serial CAS data in the corresponding time slots.

TT0 **Time slot 0 Transparent Mode**
 0 = Normal operation.
 1 = All information for time slot 0 on port XDI is inserted in the outgoing pulseframe. All internal information of the FALC56 (framing, CRC, S_a/S_i-bit signaling, remote alarm) is ignored. This function is mainly useful for system test applications (test loops). Priority sequence of transparent modes: XSP.TT0 > TSWM.

EBP **E-Bit Polarity**
 0 = In the basic- and multiframe asynchronous state the E-bit is cleared.
 1 = In the basic- and multiframe asynchronous state the E-bit is set. If automatic transmission of submultiframe status is enabled by setting bit XSP.AXS and the receiver has lost synchronization, the E-bit with the programmed polarity is inserted automatically in S_i-bit position of every outgoing CRC multiframe (under the condition that time slot 0 transparent mode and transparent S_i bit in service word are both disabled).

AXS **Automatic Transmission of Submultiframe Status**
 Only applicable to CRC multiframe.
 0 = Normal operation.
 1 = Information of submultiframe status bits RSP.SI1 and RSP.SI2 are inserted automatically in S_i -bit positions of the outgoing CRC multiframe (RSP.SI1 → S_i -bit of frame 13; RSP.SI2 → S_i-bit of frame 15). Contents of XSP.XS13 and XSP.XS15 is

ignored. If one of the time slot 0 transparent modes XSP.TT0 or TSWM.TSIS is enabled, bit XSP.AXS has no function.

XSIF **Transmit Spare Bit For International Use (FAS Word)**
First bit in the FAS word. Only significant in doubleframe format. If not used, this bit should be fixed to "1". If one of the time slot 0 transparent modes is enabled (bits XSP.TT0, or TSWM.TSIF), bit XSP.XSIF is ignored.

XS13 **Transmit Spare Bit (Frame 13, CRC-Multiframe)**
First bit in the service word of frame 13 for international use. Only significant in CRC-multiframe format. If not used, this bit should be fixed to "1". The information of XSP.XS13 is shifted into internal transmission buffer with beginning of the next following transmitted CRC multiframe.
If automatic transmission of submultiframe status is enabled by bit XSP.AXS, or, if one of the time slot 0 transparent modes XSP.TT0 or TSWM.TSIS is enabled, bit XSP.XS13 is ignored.

XS15 **Transmit Spare Bit (Frame 15, CRC-Multiframe)**
First bit in the service word of frame 15 for international use. Only significant in CRC-multiframe format. If not used, this bit should be fixed to "1". The information of XSP.XS15 is shifted into the internal transmission buffer with beginning of the next following transmitted CRC multiframe.
If automatic transmission of submultiframe status is enabled by bit XSP.AXS, or, if one of the time slot 0 transparent modes XSP.TT0 or TSWM.TSIF is enabled, bit XSP.XS15 is ignored.

Transmit Control 0 (Read/Write)

Value after reset: 00_H

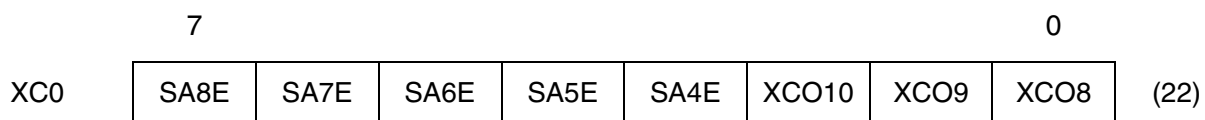

SA(8:4)E **S_a-Bit Signaling Enable**
0 = Standard operation.
1 = Setting this bit makes it possible to send/receive a LAPD protocol in any combination of the S_a-bit positions in the outgoing/incoming data stream. The on chip signaling controller has to be configured in the HDLC/LAPD mode. In transmit

direction together with these bits the TSWM.TSA(8:4) bits must be set to enable transmission to the remote end transparently through the FALC56.

XCO(10:8) Transmit Offset

Initial value loaded into the transmit bit counter at the trigger edge of SCLKX when the synchronous pulse on port $\overline{\text{SYPX}}/\text{XMFS}$ is active. Refer to register XC1.

Transmit Control 1 (Read/Write)

Value after reset: 9C_H

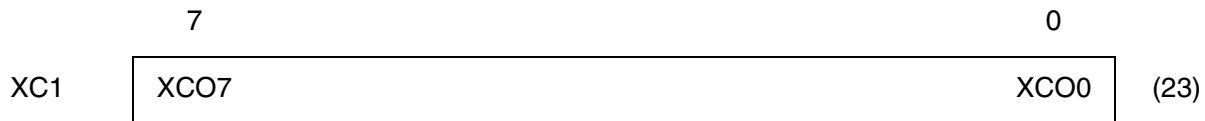

A write access to this address resets the transmit elastic buffer to its basic starting position. Therefore, updating the value should only be done when the FALC56 is initialized or when the buffer should be centered. As a consequence a transmit slip will occur.

XCO(7:0) Transmit Offset

Calculation of delay time T (SCLKX cycles) depends on the value X of the “Transmit Offset” register XC(1:0):

$0 \leq T \leq 4: X = 4 - T$

$5 \leq T \leq \text{maximum delay}: X = 256 \times \text{SC}/\text{SD} - T + 4$

with maximum delay = $(256 \times \text{SC}/\text{SD}) - 1$

with SC = system clock defined by SIC1.SSC(1:0)

with SD = 2.048 MHz

Delay time T = time between beginning of time slot 0 (bit 0, channel phase 0) at XDI/XSIG and the initial edge of SCLKX after $\overline{\text{SYPX}}/\text{XMFS}$ goes active.

See [page 111](#) for further description.

Receive Control 0 (Read/Write)

Value after reset: 00_H

	7							0	
RC0	SWD	ASY4	CRCI	XCRCI	RDIS	RCO10	RCO9	RCO8	(24)

SWD Service Word Condition Disable

0 = Standard operation. Three or four consecutive incorrect service words (depending on bit RC0.ASY4) causes loss of synchronization.

1 = Errors in service words have no influence when in synchronous state. However, they are used for the resynchronization procedure.

ASY4 Select Loss of Sync Condition

0 = Standard operation. Three consecutive incorrect FAS words or three consecutive incorrect service words causes loss of synchronization.

1 = Four consecutive incorrect FAS words or four consecutive incorrect service words causes loss of synchronization. The service word condition is disabled by bit RC0.SWD.

CRCI Automatic CRC4 Bit Inversion

If set, all CRC bits of one outgoing submultiframe are inverted in case a CRC error is flagged for the previous received submultiframe. This function is logically ored with RC0.XCRCI.

XCRCI Transmit CRC4 Bit Inversion

If set, the CRC bits in the outgoing data stream are inverted before transmission. This function is logically ored with RC0.CRCI.

RDIS Receive Data Input Sense

Digital interface, dual-rail:

0 = Inputs RDIP/RDIN are active low

1 = Inputs RDIP/RDIN are active high

Digital Interface, CMI:

0 = Input ROID is active high

1 = Input ROID is active low

RCO(10:8) Receive Offset/Receive Frame Marker Offset

Depending on the $\overline{RP(A\ to\ D)}$ pin function different offsets can be programmed. The \overline{SYPR} and the RFM pin function cannot be selected in parallel.

Receive Offset (PC(4:1).RPC(2:0) = 000)

Initial value loaded into the receive bit counter at the trigger edge of SCLKR when the synchronous pulse on port \overline{SYPR} is active.

Calculation of delay time T (SCLKR cycles) depends on the value X of the receive offset register RC(1:0). For programming refer to register RC1.

Receive Frame Marker Offset (PC(4:1).RPC(2:0) = 001_B)

Offset programming of the receive frame marker which is output on port \overline{SYPR} . The receive frame marker can be activated during any bit position of the current frame.

Calculation of the value X of the receive offset register RC(1:0) depends on the bit position which should be marked and SCLKR. Refer to register RC1.

Receive Control 1 (Read/Write)

Value after reset: 9C_H

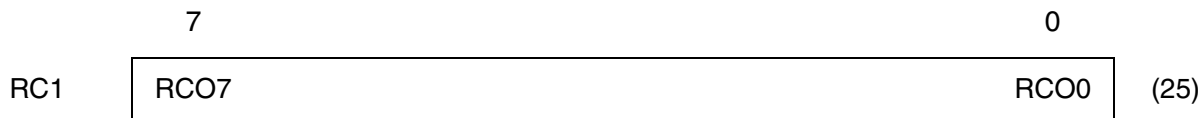

RCO(7:0) Receive Offset/Receive Frame Marker Offset

Depending on the $\overline{RP(A\ to\ D)}$ pin function different offsets can be programmed. The \overline{SYPR} and the RFM pin function cannot be selected in parallel.

Receive Offset (PC(4:1).RPC(2:0) = 000)

Initial value loaded into the receive bit counter at the trigger edge of SCLKR when the synchronous pulse on port \overline{SYPR} is active.

Calculation of delay time T (SCLKR cycles) depends on the value X of the receive offset register RC(1:0):

$0 \leq T \leq 4: X = 4 - T$

$5 \leq T \leq \text{maximum delay}: X = 2052 - T$

with maximum delay = (256×SC/SD) -1

with SC = system clock defined by SIC1.SSC(1:0)

with SD = system data rate

E1 Registers

Delay time T = time between beginning of time slot 0 at RDO and the initial edge of SCLKR after $\overline{\text{SYPR}}$ goes active.

See [page 106](#) for further description.

Receive Frame Marker Offset (PC(4:1).RPC(2:0) = 001_B)

Offset programming of the receive frame marker which is output on multifunction port RFM. The receive frame marker can be activated during any bit position of the entire frame and depends on the selected system clock rate.

Calculation of the value X of the receive offset register RC(1:0) depends on the bit position which should be marked at marker position MP:

$0 \leq \text{MP} \leq 2045: X = \text{MP} + 2$

$2046 \leq \text{MP} \leq 2047: X = \text{MP} - 2046$

e.g: 2.048 MHz: MP = 0 to 255; up to 16.384 MHz: MP = 0 to 2047

Transmit Pulse Mask (Read/Write)

Value after reset: 7B_H, 03_H, 40_H

	7						0		
XPM0	XP12	XP11	XP10	XP04	XP03	XP02	XP01	XP00	(26)
XPM1	XP30	XP24	XP23	XP22	XP21	XP20	XP14	XP13	(27)
XPM2	0	XLT	DAXLT		XP34	XP33	XP32	XP31	(28)

The transmit pulse shape which is defined in ITU-T G.703 is output on pins XL1 and XL2. The level of the pulse shape can be programmed by registers XPM(2:0) to create a custom waveform. In order to get an optimized pulse shape for the external transformers each pulse shape is internally divided into four sub pulse shapes. In each sub pulse shape a programmed 5 bit value defines the level of the analog voltage on pins XL1/2. Together four 5 bit values have to be programmed to form one complete transmit pulse shape. The four 5 bit values are sent in the following sequence:

- XP04 to 00: First pulse shape level
- XP14 to 10: Second pulse shape level
- XP24 to 20: Third pulse shape level
- XP34 to 30: Fourth pulse shape level

Changing the LSB of each subpulse in registers XPM(2:0) changes the amplitude of the differential voltage on XL1/2 by approximately 80 mV.

Example: 120 Ω interface and wired as shown in [Figure 50](#) on [page 155](#).

- XP04 to 00: 1B_H or 27 decimal
- XP14 to 10: 1B_H or 27 decimal
- XP24 to 20: 00_H
- XP34 to 30: 00_H

Programming values for XPM(2:0): 00_H, 03_H, 7B_H

XLT

Transmit Line Tristate

- 0 = Normal operation
- 1 = Transmit line XL1/XL2 or XDOP/XDON are switched into high-impedance state. If this bit is set the transmit line monitor status information is frozen (default value after hardware reset).

DAXLT Disable Automatic Tristating of XL1/2

- 0 = Normal operation. If a short is detected on pins XL1/2 the transmit line monitor sets the XL1/2 outputs into a high-impedance state.
- 1 = If a short is detected on XL1/2 pins automatic setting these pins into a high-impedance (by the XL-monitor) state is disabled.

Transparent Service Word Mask (Read/Write)

Value after reset: 00_H

		7					0		
TSWM	TSIS	TSIF	TRA	TSA4	TSA5	TSA6	TSA7	TSA8	(29)

TSWM(7:0) Transparent Service Word Mask

TSIS Transparent S_i-Bit in Service Word

- 0 = The S_i-Bit is generated internally.
- 1 = The S_i-Bit in the service word is taken from port XDI and transparently passed through the FALC56 without any changes. The internal information of the FALC56 (register XSW) is ignored.

TSIF Transparent S_i-Bit in FAS Word

- 0 = The S_i-Bit is generated internally.
- 1 = The S_i-Bit in the FAS word is taken from port XDI and routed transparently through the FALC56 without any changes. The internal information of the FALC56 (register XSW) is ignored.

TRA Transparent Remote Alarm

- 0 = The remote alarm bit is generated internally.
- 1 = The A-Bit is taken from port XDI and routed transparently through the FALC56 without any changes. The internal information of the FALC56 (register XSW) is ignored.

TSA(8:4)

Transparent S_a(8:4)-Bit

- 0 = The S_a(8:4)-bits are generated internally.
- 1 = The S_a(8:4)-bits are taken from port XDI or from the internal signaling controller if enabled and transparently passed through the FALC56 without any changes. The internal information of the FALC56 (registers XSW and XSA(8:4)) is ignored.

Idle Channel Code Register (Read/Write)

Value after reset: 00_H

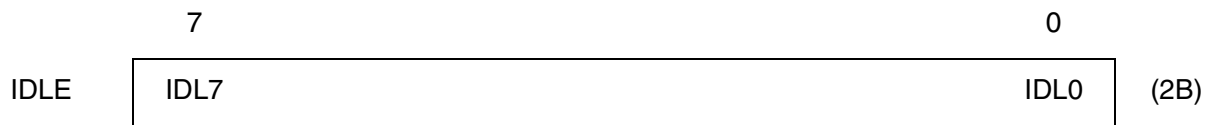

IDL(7:0)

Idle Channel Code

If channel loop-back is enabled by programming LOOP.ECLB = 1, the contents of the assigned outgoing channel on ports XL1/XL2 or XDOP/XDON is set equal to the idle channel code selected by this register.

Additionally, the specified pattern overwrites the contents of all channels selected by the idle channel registers ICB(4:1). IDL7 is transmitted first.

Transmit S_a(8:4) Register (Read/Write)

Value after reset: 00_H, 00_H, 00_H, 00_H, 00_H

	7							0	
XSA4	XS47	XS46	XS45	XS44	XS43	XS42	XS41	XS40	(2C)
XSA5	XS57	XS56	XS55	XS54	XS53	XS52	XS51	XS50	(2D)
XSA6	XS67	XS66	XS65	XS64	XS63	XS62	XS61	XS60	(2E)
XSA7	XS77	XS76	XS75	XS74	XS73	XS72	XS71	XS70	(2F)
XSA8	XS87	XS86	XS85	XS84	XS83	XS82	XS81	XS80	(30)

XSA(8:4)

Transmit S_a-Bit Data

The S_a-bit register access is enabled by setting bit FMR1.ENSA = 1. With the transmit multiframe begin an interrupt ISR1.XMB is generated and the contents of these registers XSA(8:4) is copied into a shadow register. The contents is subsequently sent out in the service words of the next outgoing CRC multiframe (or doubleframes) if none of the time slot 0 transparent modes is enabled. XS40 is sent out in bit position 4 in frame 1, XS47 in frame 15. The transmit multiframe begin interrupt XMB request that these registers should be serviced. If requests for new information are ignored, current contents is repeated.

EXTIW Extended CRC4 to Non-CRC4 Interworking

Only valid in multiframe format. This bit selects the reaction of the synchronizer after the 400 ms time-out has been elapsed and starts transmitting a remote alarm if FMR2.AXRA is set.

0 = The CRC4 to Non CRC4 interworking is done as described in ITU-T G. 706 Annex B.

1 = The interworking is done according to ITU-T G. 706 with the exception that the synchronizer still searches the multiframing even if the 400 ms timer is expired. Switching into doubleframe format is disabled. If FMR2.AXRA is set the remote alarm bit is active in the outgoing data stream until the multiframe is found.

Idle Channel Register (Read/Write)

Value after reset: 00_H, 00_H, 00_H, 00_H

	7							0	
ICB1	IC0	IC1	IC2	IC3	IC4	IC5	IC6	IC7	(32)
ICB2	IC8	IC9	IC10	IC11	IC12	IC13	IC14	IC15	(33)
ICB3	IC16	IC17	IC18	IC19	IC20	IC21	IC22	IC23	(34)
ICB4	IC24	IC25	IC26	IC27	IC28	IC29	IC30	IC31	(35)

IC(31:0) Idle Channel Selection Bits

These bits define the channels (time slots) of the outgoing PCM frame to be altered.

Assignments:

IC0 → Time slot 0

IC1 → Time slot 1

...

IC31 → Time slot 31

0 = Normal operation.

1 = Idle channel mode. The contents of the selected time slot is overwritten by the idle channel code defined by register IDLE.

Note: Although time slot 0 can be selected by bit IC0, its contents is only altered if the transparent mode is selected (XSP.TT0).

Line Interface Mode 0 (Read/Write)

Value after reset: 00_H

	7						0	
LIM0	XFB	XDOS			EQON	RLM	LL	MAS (36)

- XFB** **Transmit Full Bauded Mode**
 Only applicable for dual-rail mode (bit LIM1.DRS = 1).
 0 = Output signals XDOP/XDON are half bauded.
 1 = Output signals XDOP/XDON are full bauded.
 Note: If CMI coding is selected (FMR0.XC(1:0) = 01) this bit has to be cleared.
- XDOS** **Transmit Data Out Sense**
 0 = Output signals XDOP/XDON are active low. Output XOID is active high (normal operation).
 1 = Output signals XDOP/XDON are active high. Output XOID is active low.
 Note: If CMI coding is selected (FMR0.XC(1:0) = 01) this bit has to be cleared.
 The transmit frame marker XFM is independent of this bit.
- EQON** **Receive Equalizer On**
 0 = -10 dB receiver, short-haul mode
 1 = -43 dB receiver, long-haul mode
- RLM** **Receive Line Monitoring**
 0 = Normal receiver mode
 1 = Receiver mode for receive line monitoring; the receiver sensitivity is increased to detect resistively attenuated signals of -20 dB (short-haul mode only)
- LL** **Local Loop**
 0 = Normal operation
 1 = Local loop active. The local loop-back mode disconnects the receive lines RL1/RL2 or RDIP/RDIN from the receiver. Instead of the signals coming from the line the data provided by system interface are routed through the analog receiver back to the system interface. The unipolar bit stream is transmitted

undisturbedly on the line. Receiver and transmitter coding must be identical. Operates in analog and digital line interface mode. In analog line interface mode data is transferred through the complete analog receiver.

MAS

Master Mode

- 0 = Slave mode
- 1 = Master mode on. Setting this bit the DCO-R circuitry is frequency synchronized to the clock (2.048 MHz or 8 kHz, see IPC.SSYF) supplied by SYNC. If this pin is connected to V_{SS} or V_{DD} (or left open and pulled up to V_{DD} internally) the DCO-R circuitry is centered and no receive jitter attenuation is performed (only if 2.048 MHz clock is selected by resetting bit IPC.SSYF). The generated clocks are stable.

Line Interface Mode 1 (Read/Write)

Value after reset: 00_H

	7						0		
LIM1	CLOS	RIL2	RIL1	RIL0		JATT	RL	DRS	(37)

CLOS = Clear data in case of LOS

- 0 = Normal receiver mode, receive data stream is transferred normally in long-haul mode
- 1 = In long-haul mode received data is cleared (driven to low level), as soon as LOS is detected

RIL(2:0) Receive Input Threshold

Only valid if analog line interface is selected (LIM1.DRS = 0).
 "No signal" is declared if the voltage between pins RL1 and RL2 drops below the limits programmed by bits RIL(2:0) and the received data stream has no transition for a period defined in the PCD register.
 The threshold where "no signal" is declared is programmable by the RIL(2:0) bits depending on bit LIM0.EQON.
 Note: LIM1.RIL(2:0) must be programmed before LIM0.EQON = 1 is set.

See DC characteristics for detail.

JATT, RL

Remote Loop Transmit Jitter Attenuator

00 = Normal operation. The remote loop transmit jitter attenuator is disabled. Transmit data bypasses the remote loop jitter attenuator buffer.

01 = Remote loop active without remote loop transmit jitter attenuator enabled. Transmit data bypasses the remote loop jitter attenuator buffer.

10 = not defined

11 = Remote loop and remote loop jitter attenuator active. Received data from pins RL1/2 or RDIP/N or ROID is sent "jitter-free" on ports XL1/2 or XDOP/N or XOID. The de-jittered clock is generated by the DCO-X circuitry.

Note: JATT is only used to define the jitter attenuation during remote loop operation. Jitter attenuation during normal operation is not affected.

DRS

Dual-Rail Select

0 = The ternary interface is selected. Multifunction ports RL1/2 and XL1/2 become analog in/outputs.

1 = The digital dual-rail interface is selected. Received data is latched on multifunction ports RDIP/RDIN while transmit data is output on pins XDOP/XDON.

Pulse Count Detection Register (Read/Write)

Value after reset: 00_H

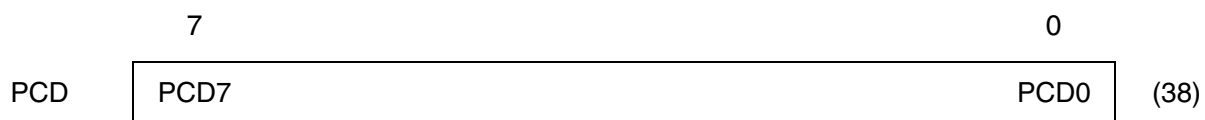

PCD(7:0)

Pulse Count Detection

A LOS alarm is detected if the incoming data stream has no transitions for a programmable number T consecutive pulse positions. The number T is programmable by the PCD register and can be calculated as follows:

$$T = 16 \times (N+1); \text{ with } 0 \leq N \leq 255.$$

The maximum time is: $256 \times 16 \times 488 \text{ ns} = 2 \text{ ms}$. Every detected pulse resets the internal pulse counter. The counter is clocked with the receive clock RCLK.

Pulse Count Recovery (Read/Write)

Value after reset: 00_H

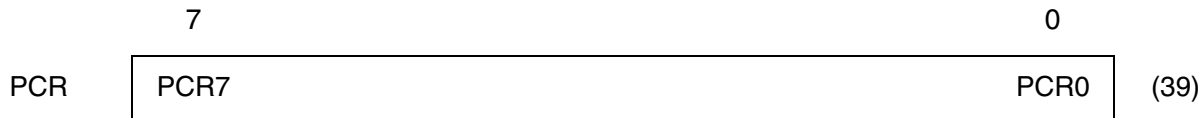

PCR(7:0) Pulse Count Recovery

A LOS alarm is cleared if a pulse-density is detected in the received bit stream. The number of pulses M which must occur in the predefined PCD time interval is programmable by the PCR register and can be calculated as follows:

$$M = N+1; \text{ with } 0 \leq N \leq 255.$$

The time interval starts with the first detected pulse transition. With every received pulse a counter is incremented and the actual counter is compared to the contents of PCR register. If the pulse number is higher or equal to the PCR value the LOS alarm is reset otherwise the alarm stays active. In this case the next detected pulse transition starts a new time interval.

Line Interface Mode 2 (Read/Write)

Value after reset: 20_H

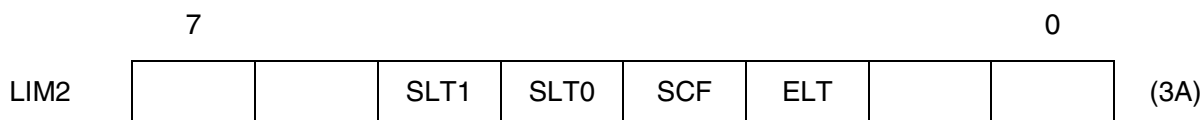

SLT(1:0) Receive Slicer Threshold

- 00 = The receive slicer generates a mark (digital one) if the voltage at RL1/2 exceeds 55% of the peak amplitude.
- 01 = The receive slicer generates a mark (digital one) if the voltage at RL1/2 exceeds 67% of the peak amplitude (recommended in some T1/J1 applications).
- 10 = The receive slicer generates a mark (digital one) if the voltage at RL1/2 exceeds 50% of the peak amplitude (default, recommended in E1 mode).
- 11 = The receive slicer generates a mark (digital one) if the voltage at RL1/2 exceeds 45% of the peak amplitude.

SCF

Select Corner Frequency of DCO-R

Setting this bit reduces the corner frequency of the DCO-R circuit by the factor of ten to 0.2 Hz.

Note: Reducing the corner frequency of the DCO-R circuitry increases the synchronization time before the frequencies are synchronized.

ELT

Enable Loop-Timed

0 = Normal operation

1 = Transmit clock is generated from the clock supplied by MCLK which is synchronized to the extracted receive route clock. In this configuration the transmit elastic buffer has to be enabled. Refer to register XSW.XTM. For correct operation of loop timed the remote loop (bit LIM1.RL = 0) must be inactive and bit CMR1.DXSS must be cleared.

Loop Code Register 1 (Read/Write)

Value after reset: 00_H

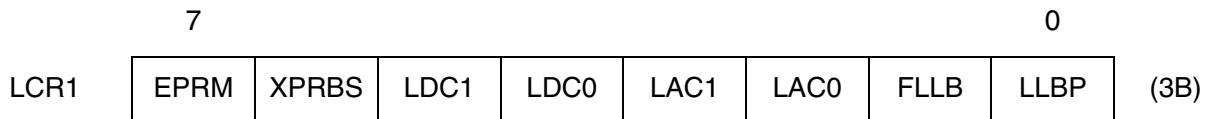

EPRM

Enable Pseudo-Random Binary Sequence Monitor

0 = Pseudo-Random Binary Sequence (PRBS) monitor is disabled.

1 = PRBS is enabled. Setting this bit enables incrementing the CEC2 error counter with each detected PRBS bit error. With any change of state of the PRBS internal synchronization status an interrupt ISR1.LLBSC is generated. The current status of the PRBS synchronizer is indicated by bit RSP.LLBAD.

XPRBS

Transmit Pseudo-Random Binary Sequence

A one in this bit position enables transmission of a pseudo-random binary sequence to the remote end. Depending on bit LLBP the PRBS is generated according to $2^{15}-1$ or $2^{20}-1$ with a maximum-14-zero restriction (ITU-T O. 151).

- LDC(1:0) Length Deactivate (Down) Code**
These bits defines the length of the LLB deactivate code which is programmable in register LCR2.
00 = Length: 5 bit
01 = Length: 6 bit, 2 bit, 3 bit
10 = Length: 7 bit
11 = Length: 8 bit, 2 bit, 4bit
- LAC(1:0) Length Activate (Up) Code**
These bits defines the length of the LLB activate code which is programmable in register LCR3.
00 = Length: 5 bit
01 = Length: 6 bit, 2 bit, 3 bit
10 = Length: 7 bit
11 = Length: 8 bit, 2 bit, 4 bit
- FLLB Framed Line Loop-Back/Invert PRBS**
Depending on bit LCR1.XPRBS this bit enables different functions:
LCR1.XPRBS = 0:
0 = The line loop-back code is transmitted including framing bits. LLB code overwrites the FS/DL-bits.
1 = The line loop-back code is transmitted unframed. LLB code does not overwrite the FS/DL-bits.
- Invert PRBS**
LCR1.XPRBS = 1:
0 = The generated PRBS is transmitted not inverted.
1 = The PRBS is transmitted inverted.
- LLBP Line Loop-Back Pattern**
LCR1.XPRBS = 0
0 = Fixed line loop-back code according to ANSI T1. 403.
1 = Enable user-programmable line loop-back code by register LCR2/3.
LCR1.XPRBS = 1 or LCR1.EPRM = 1
0 = $2^{15} - 1$
1 = $2^{20} - 1$

Loop Code Register 2 (Read/Write)

Value after reset: 00_H

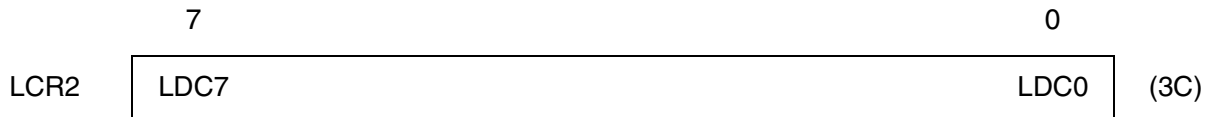

LDC(7:0) Line Loop-Back Deactivate Code

If enabled by bit FMR3.XLD = 1 the LLB deactivate code automatically repeats until the LLB generator is stopped. Transmit data is overwritten by the LLB code. LDC0 is transmitted last. For correct operations bit LCR1.XPRBS has to cleared.

If LCR2 is changed while the previous deactivate code has been detected and is still received, bit RSP.LLBDD will stay active until the incoming signal changes or a receiver reset is initiated (CMDR.RRES = 1).

Loop Code Register 3 (Read/Write)

Value after reset: 00_H

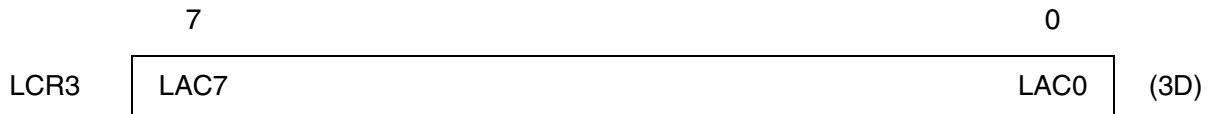

LAC(7:0) Line Loop-Back Activate Code

If enabled by bit FMR3.XLU = 1 the LLB activate code automatically repeats until the LLB generator is stopped. Transmit data is overwritten by the LLB code. LAC0 is transmitted last. For correct operations bit LCR1.XPRBS has to cleared.

If LCR3 is changed while the previous activate code has been detected and is still received, bit RSP.LLBAD will stay active until the incoming signal changes or a receiver reset is initiated (CMDR.RRES = 1).

System Interface Control 1 (Read/Write)

Value after reset: 00_H

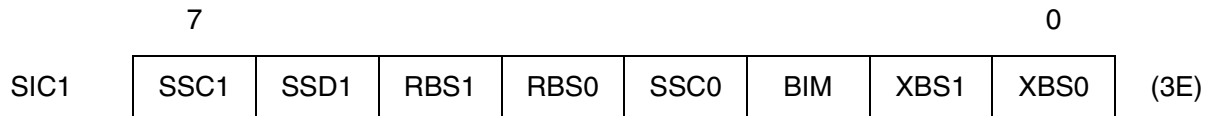

SSC(1:0) Select System Clock

SIC1.SSC(1:0) define the clocking rate on the system highway.

- 00 = 2.048 MHz
- 01 = 4.096 MHz
- 10 = 8.192 MHz
- 11 = 16.384 MHz

SSD1 Select System Data Rate 1

SIC1.SSD1 and FMR1.SSD0 define the data rate on the system highway. Programming SSD1/SSD0 and corresponding data rate is shown below.

- 00 = 2.048 Mbit/s
- 01 = 4.096 Mbit/s
- 10 = 8.192 Mbit/s
- 11 = 16.384 Mbit/s

RBS(1:0) Receive Buffer Size

- 00 = Buffer size: 2 frames
- 01 = Buffer size: 1 frame
- 10 = Buffer size: 96 bits
- 11 = bypass of receive elastic store

BIM Bit Interleaved Mode

- 0 = Byte interleaved mode
- 1 = Bit interleaved mode

XBS(1:0) Transmit Buffer Size

- 00 = Bypass of transmit elastic store
- 01 = Buffer size: 1 frame
- 10 = Buffer size: 2 frames
- 11 = Buffer size: 96 bits

System Interface Control 2 (Read/Write)

Value after reset: 00_H

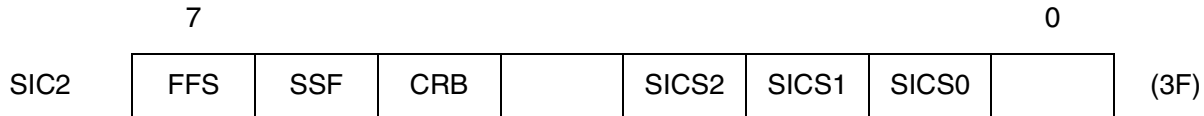

FFS

Force Freeze Signaling

Setting this bit disables updating of the receive signaling buffer and current signaling information is frozen. After resetting this bit and receiving a complete superframe updating of the signaling buffer is started again. The freeze signaling status can also be automatically generated by detecting the loss-of-signal alarm or a loss of CAS frame alignment or a receive slip (only if external register access on pin RSIG is enabled). This automatic freeze signaling function is logically ored with this bit.

The current internal freeze signaling status is output on pin RPA to RPD using pin function FREEZE which is selected by PC(4:1).RPC(2:0) = 110. Additionally, this status is also available in register SIS.SFS.

SSF

Serial Signaling Format

Only applicable if pin function RSIG/XSIG and SIC3.TTRF = 0 is selected.

0 = Bits 1 to 4 in all time slots except time slots 0 and 16 are cleared.

1 = Bits 1 to 4 in all time slots except time slots 0 and 16 are set high.

CRB

Center Receive Elastic Buffer

Only applicable if the time slot assigner is disabled (PC(4:1).RPC(2:0) = 001_B), no external or internal synchronous pulse receive is generated.

A transition from low to high forces a receive slip and the read- pointer of the receive elastic buffer is centered. The delay through the buffer is set to one half of the current buffer size. It should be hold high for at least two 2.048 MHz periods before it is cleared.

SICS(2:0)

System Interface Channel Select

Only applicable if the system clock rate is greater than 2.048 MHz.

Received data is transmitted on pin RDO/RSIG or received on XDI/XSIG with the selected system data rate. If the data rate is greater than 2.048 Mbit/s the data is output or sampled in half, a quarter or

E1 Registers

one eighth of the time slot. Data is not repeated. The time while data is active during a 8×488 ns time slot is called a channel phase. RDO/RSIG are cleared (driven to low level) while XDI/XSIG are ignored for the remaining time of the 8×488 ns or for the remaining channel phases. The channel phases are selectable with these bits.

000 = Data active in channel phase 1, valid if system data rate is 16/8/4 Mbit/s

001 = Data active in channel phase 2, valid if system data rate is 16/8/4 Mbit/s

010 = Data active in channel phase 3, valid if data rate is 16/8 Mbit/s

011 = Data active in channel phase 4, valid if data rate is 16/8 Mbit/s

100 = Data active in channel phase 5, valid if data rate is 16 Mbit/s

101 = Data active in channel phase 6, valid if data rate is 16 Mbit/s

110 = Data active in channel phase 7, valid if data rate is 16 Mbit/s

111 = Data active in channel phase 8, valid if data rate is 16 Mbit/s

System Interface Control 3 (Read/Write)

Value after reset: 00_H

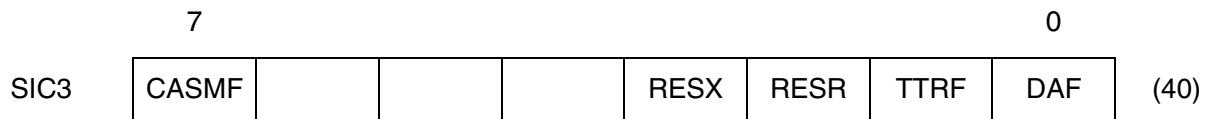

CASMf

CAS Multiframe Begin Marker

0 = The time slot 0 multiframe begin is asserted on pin RP(A to D)/pin function RMFB.

1 = The time slot 16 CAS multiframe begin is asserted on pin RP(A to D)/pin function RMFB.

- RESX** **Rising Edge Synchronous Pulse Transmit**
- Depending on this bit all transmit system interface data and marker are clocked or sampled with the selected active edge.
- CMR2.IXSC = 0:
- 0 latched with the first falling edge of the selected PCM highway clock.
 - 1 latched with the first rising edge of the selected PCM highway clock.
- CMR2.IXSC = 1:
- value of RESX bit has no impact on the selected edge of the PCM highway clock but value of $\overline{\text{RESR}}$ bit is used as RESX.
- Example: If RESR = 0, the rising edge of PCM highway clock is the selected one for sampling data on XDI and vice versa.
- RESR** **Rising Edge Synchronous Pulse Receive**
- Depending on this bit all receive system interface data and marker are clocked with the selected active edge.
- 0 = Latched with the first falling edge of the selected PCM highway clock.
 - 1 = Latched with the first rising edge of the selected PCM highway clock.
- Note: If bit CMR2.IRSP is set, the behavior of signal RFM (if used) is inverse (1 = falling edge, 0 = rising edge)
- TTRF** **TTR Register Function (Fractional E1 Access)**
- Setting this bit the function of the TTR(4:1) registers is changed. A one in each TTR register forces the XSIGM marker high for the corresponding time slot and controls sampling of the time slots provided on pin XSIG. XSIG is selected by PC(4:1).XPC(3:0).
- DAF** **Disable Automatic Freeze**
- 0 = Signaling is automatically frozen if one of the following alarms occurred: Loss-Of-Signal (FRS0.LOS), Loss of CAS Frame Alignment (FRS1.TS16LFA), or receive slips (ISR3.RSP/N).
 - 1 = Automatic freezing of signaling data is disabled. Updating of the signaling buffer is also done if one of the above described alarm conditions is active. However, updating of the signaling buffer is stopped if SIC2.FFS is set. Significant only if the serial signaling access is enabled.

Clock Mode Register 1 (Read/Write)

Value after reset: 00_H

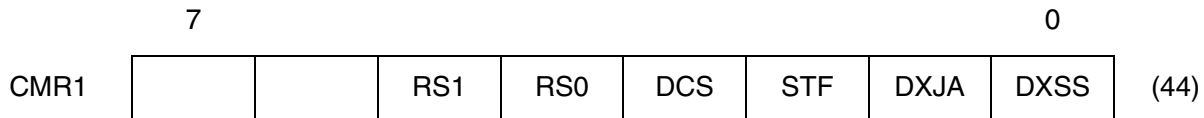

RS(1:0) Select RCLK Source

These bits select the source of RCLK.

- 00 = Clock recovered from the line through the DPLL drives RCLK
- 01 = Clock recovered from the line through the DPLL drives RCLK and in case of an active LOS alarm RCLK pin is set high.
- 10 = Clock recovered from the line is de-jittered by DCO-R to drive a 2.048 MHz clock on RCLK.
- 11 = Clock recovered from the line is de-jittered by DCO-R to drive a 8.192 MHz clock on RCLK.

DCS Disable Clock-Switching

In Slave mode (LIM0.MAS = 0) the DCO-R is synchronized on the recovered route clock. In case of loss-of-signal LOS the DCO-R switches automatically to the clock sourced by port SYNC. Setting this bit automatic switching from RCLK to SYNC is disabled.

STF Select TCLK Frequency

Only applicable if the pin function TCLK port XP(A to D) is selected by PC(4:1).XPC(3:0) = 0011_B. Data on XL1/2 (XDOP/N / XOID) are clocked with TCLK.

- 0 = 2.048 MHz
- 1 = 8.192 MHz

DXJA Disable Internal Transmit Jitter Attenuation

Setting this bit disables the transmit jitter attenuation. Reading the data out of the transmit elastic buffer and transmitting on XL1/2 (XDOP/N/XOID) is done with the clock provided on pin TCLK. In transmit elastic buffer bypass mode the transmit clock is taken from SCLKX, independent of this bit.

DXSS

DCO-X Synchronization Clock Source

0 = The DCO-X circuitry synchronizes to the internal reference clock which is sourced by SCLKX/R or RCLK. Since there are many reference clock opportunities the following internal prioritizing in descending order from left to right is realized: LIM1.RL > CMR1.DXSS > LIM2.ELT > current working clock of transmit system interface.

If one of these bits is set the corresponding reference clock is taken.

1 = DCO-X synchronizes to an external reference clock provided on pin XP(A to D) pin function TCLK, if no remote loop is active. TCLK is selected by PC(4:1).XPC(3:0) = 0011_B.

Clock Mode Register 2 (Read/Write)

Value after reset: 00_H

	7						0		
CMR2			DCOXC	DCF	IRSP	IRSC	IXSP	IXSC	(45)

DCOXC

DCO-X Center-Frequency Enable

0 = The center function of the DCO-X circuitry is disabled.

1 = The center function of the DCO-X circuitry is enabled. DCO-X centers to 2.048 MHz related to the master clock reference (MCLK), if reference clock (e.g. SCLKX) is missing.

DCF

DCO-R Center- Frequency Disabled

0 = The DCO-R circuitry is frequency centered
 - in master mode if no 2.048 MHz reference clock on pin SYNC is provided or
 - in slave mode if a loss-of-signal occurs in combination with no 2.048 MHz clock on pin SYNC or
 - a gapped clock is provided on pin RCLKI and this clock is inactive or stopped.

1 = The center function of the DCO-R circuitry is disabled. The generated clock (DCO-R) is frequency frozen in that moment when no clock is available on pin SYNC or pin RCLKI. The DCO-R circuitry starts synchronization as soon as a clock appears on pins SYNC or RCLKI.

IRSP**Internal Receive System Frame Sync Pulse**

0 = The frame sync pulse for the receive system interface is sourced by $\overline{\text{SYPR}}$ (if $\overline{\text{SYPR}}$ is applied). If $\overline{\text{SYPR}}$ is not applied, the frame sync pulse is derived from RDO output signal internally free running).

The use of IRSP = 0 is recommended.

1 = The frame sync pulse for the receive system interface is internally sourced by the DCO-R circuitry. This internally generated frame sync signal can be output (active low) on multifunction ports RP(A to D) ($\text{RPC}(2:0) = 001_B$).

Note: This is the only exception where the use of RFM and $\overline{\text{SYPR}}$ is allowed at the same time. Because only one set of offset registers (RC1/0) is available, programming is done by using the $\overline{\text{SYPR}}$ calculation formula in the same way as for the external $\overline{\text{SYPR}}$ pulse. Bit IRSC must be set for correct operation.

IRSC**Internal Receive System Clock**

0 = The working clock for the receive system interface is sourced by SCLKR or in receive elastic buffer bypass mode from the corresponding extracted receive clock RCLK.

1 = The working clock for the receive system interface is sourced internally by DCO-R or in bypass mode by the extracted receive clock. SCLKR is ignored.

IXSP**Internal Transmit System Frame Sync Pulse**

0 = The frame sync pulse for the transmit system interface is sourced by $\overline{\text{SYPX}}$.

1 = The frame sync pulse for the transmit system interface is internally sourced by the DCO-R circuitry. Additionally, the external XMFS signal defines the transmit multiframe begin. XMFS is enabled or disabled by the multifunction port configuration. For correct operation bits CMR2.IXSC/IRSC must be set. $\overline{\text{SYPX}}$ is ignored.

IXSC**Internal Transmit System Clock**

0 = The working clock for the transmit system interface is sourced by SCLKX.

1 = The working clock for the transmit system interface is sourced internally by the working clock of the receive system interface. SCLKX is ignored.

Global Configuration Register (Read/Write)

Value after reset: 00_H

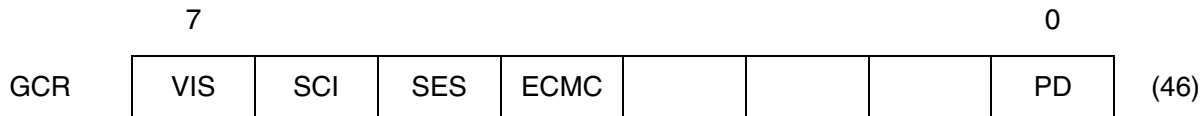

- VIS** **Masked Interrupts Visible**
- 0 = Masked interrupt status bits are not visible in registers ISR(5:0).
 - 1 = Masked interrupt status bits are visible in ISR(5:0), but they are not visible in register GIS.
- SCI** **Status Change Interrupt**
- 0 = Interrupts are generated either on activation or deactivation of the internal interrupt source.
 - 1 = The following interrupts are activated both on activation and deactivation of the internal interrupt source:
ISR2.LOS, ISR2.AIS, ISR3.LMFA16
- SES** **Select External Second Timer**
- 0 = Internal second timer selected
 - 1 = External second timer selected
- ECMC** **Error Counter Mode COFA**
- 0 = The S_a6-bit error indications are accumulated in the error counter CEC3L/H.
 - 1 = A Change of Frame or Multiframe Alignment COFA is detected since the last resynchronization. The events are accumulated in the error counter CEC3L.(1:0).
Multiframe periods received in the asynchronous state are accumulated in the error counter CEC3L.7-2.
An overflow of each counter is disabled.
- PD** **Power Down**
- Switches between power-up and power-down mode.
- 0 = Power up
 - 1 = Power down
All outputs are driven inactive; multifunction ports are driven high by the weak internal pullup device.

Errored Second Mask (Read/Write)

Value after reset: FF_H

	7							0	
ESM	LFA	FER	CER	AIS	LOS	CVE	SLIP	EBE	(47)

ESM Errored Second Mask

This register functions as an additional mask register for the interrupt status bit Errored Second (ISR3.ES). A "1" in a bit position of ESM deactivates the related second interrupt.

Disable Error Counter (Write)

Value after reset: 00_H

	7							0	
DEC	DRBD		DCEC3	DCEC2	DCEC1	DEBC	DCVC	DFEC	(60)

DRBD Disable Receive Buffer Delay

This bit has to be set before reading the register RBD. It is reset automatically if RBD has been read.

DCEC3 Disable CRC Error Counter 3

DCEC2 Disable CRC Error Counter 2

DCEC1 Disable CRC Error Counter

DEBC Disable Errored Block Counter

DCVC Disable Code Violation Counter

DFEC Disable Framing Error Counter

These bits are only valid if FMR1.ECM is cleared. They have to be set before reading the error counters. They are reset automatically if the corresponding error counter high byte has been read. With the rising edge of these bits the error counters are latched and then cleared.

Note: Error counters and receive buffer delay can be read 1 μs after setting the according bit in bit DEC.

Transmit CAS Register (Write)

Value after reset: not defined

Table 59 Transmit CAS Registers (E1)

	7				0				
XS1	0	0	0	0	X	Y	X	X	(70)
XS2	A1	B1	C1	D1	A16	B16	C16	D16	(71)
XS3	A2	B2	C2	D2	A17	B17	C17	D17	(72)
XS4	A3	B3	C3	D3	A18	B18	C18	D18	(73)
XS5	A4	B4	C4	D4	A19	B19	C19	D19	(74)
XS6	A5	B5	C5	D5	A20	B20	C20	D20	(75)
XS7	A6	B6	C6	D6	A21	B21	C21	D21	(76)
XS8	A7	B7	C7	D7	A22	B22	C22	D22	(77)
XS9	A8	B8	C8	D8	A23	B23	C23	D23	(78)
XS10	A9	B9	C9	D9	A24	B24	C24	D24	(79)
XS11	A10	B10	C10	D10	A25	B25	C25	D25	(7A)
XS12	A11	B11	C11	D11	A26	B26	C26	D26	(7B)
XS13	A12	B12	C12	D12	A27	B27	C27	D27	(7C)
XS14	A13	B13	C13	D13	A28	B28	C28	D28	(7D)
XS15	A14	B14	C14	D14	A29	B29	C29	D29	(7E)
XS16	A15	B15	C15	D15	A30	B30	C30	D30	(7F)

Transmit CAS Register (16:1)

The transmit CAS register access is enabled by setting bit XSP.CASEN = 1. Each register except XS1 contains the CAS bits for two time slots. With the transmit multiframe begin ISR1.XMB the contents of these registers is copied into a shadow register. The contents is sent out subsequently in the time slots 16 of the outgoing data stream.

Note: If ISR1.XMB is not used and the write access to these registers is done exact in the moment when this interrupt is generated, data is lost.

XS1.7 is sent out first and XS16.0 is sent last. The transmit multiframe begin interrupt (XMB) requests that these registers should be serviced. If requests for new information are ignored, current contents is repeated. XS1 has to be programmed with the multiframe pattern. This pattern should always stay low otherwise the remote end loses its synchronization. With setting the Y-bit a remote alarm is transmitted to the far end. The X bits (spare bits) should be set if they are not used.

If access to these registers is done without control of the interrupt ISR1.XMB the registers should be written twice to avoid an internal data transfer error.

Note: A software reset (CMDR.XRES) resets these registers.

Port Configuration 1 to 4 (Read/Write)

Value after reset: 00_H

	7						0		
PC1		RPC12	RPC11	RPC10	XPC13	XPC12	XPC11	XPC10	(80)
PC2		RPC22	RPC21	RPC20	XPC23	XPC22	XPC21	XPC20	(81)
PC3		RPC32	RPC31	RPC30	XPC33	XPC32	XPC31	XPC30	(82)
PC4		RPC42	RPC41	RPC40	XPC43	XPC42	XPC41	XPC40	(83)

RPC(2:0) Receive multifunction port configuration

The multifunction ports RP(A to D) are bidirectional. After Reset these ports are configured as inputs. With the selection of the pin function the In/Output configuration is also achieved. The input function $\overline{\text{SYPR}}$ may only be selected once, it must not be selected twice or more. Register PC1 configures port RPA, while PC2 → port RPB, PC3 → port RPC and PC4 → port RPD.

000 = $\overline{\text{SYPR}}$: Synchronous Pulse Receive (Input)

Together with register RC(1:0) $\overline{\text{SYPR}}$ defines the frame begin on the receive system interface. Because of the offset programming the $\overline{\text{SYPR}}$ and the RFM pin function cannot be selected in parallel.

001 = RFM: Receive Frame Marker (Output)

CMR2.IRSP = 0:

The receive frame marker is active high for one 2.048 MHz period during any bit position of the current frame. Programming of the bit position is done by using registers RC(1:0). The internal time slot assigner is disabled. The RFM offset calculation formula has to be used.

CMR2.IRSP = 1:

Internally generated frame synchronization pulse sourced by the DCO-R circuitry. The pulse is active low for one 2.048 MHz period.

- 010 = RMFB: Receive Multiframe Begin (Output)
Marks the beginning of every received multiframe or optionally the begin of every CAS multiframe begin (active high).
- 011 = RSIGM: Receive Signaling Marker (Output)
Marks the time slots which are defined by register RTR(4:1) of every frame on port RDO.
- 100 = RSIG: Receive Signaling Data (Output)
The received CAS multiframe is transmitted on this pin. Time slot on RSIG correlates directly to the time slot assignment on RDO.
- 101 = DLR: Data Link Bit Receive (Output)
Marks the S_a -bits within the data stream on RDO.
- 110 = FREEZE: Freeze Signaling (Output)
The freeze signaling status is active high by detecting a loss-of-signal alarm, or a loss of CAS frame alignment or a receive slip (positive or negative). It stays high for at least one complete multiframe after the alarm disappears. Setting SIC2.FFS enforces a high on pin FREEZE.
- 111 = $\overline{\text{RFSP}}$: Receive Frame Synchronous Pulse (Output)
Marks the frame begin in the receivers synchronous state. This marker is active low for 488 ns with a frequency of 8 kHz.

XPC(3:0)

Transmit multifunction Port Configuration

The multifunction ports XP(A to D) are bidirectional. After Reset these ports are configured as inputs. With the selection of the pin function the In/Output configuration is also achieved. Each of the four different input functions ($\overline{\text{SYPX}}$, XMFS, XSIG, TCLK) may only be selected once. No input function must be selected twice or more. $\overline{\text{SYPX}}$ and XMFS should not be selected in parallel. Register PC1 configures port XPA, while PC2 → port XPB, PC3 → port XPC and PC4 → port XPD.

- 0000 = $\overline{\text{SYPX}}$: Synchronous Pulse Transmit (Input)
Together with register XC(1:0) $\overline{\text{SYPX}}$ defines the frame begin on the transmit system interface ports XDI and XSIG.
- 0001 = XMFS: Transmit Multiframe Synchronization (Input)
Together with register XC(1:0) XMFS defines the frame and multiframe begin on the transmit system interface ports XDI and XSIG. Depending on PC5.CXMFS the signal on XMFS is active high or low.
- 0010 = XSIG: Transmit Signaling Data (Input)
Input for transmit signaling data received from the signaling

E1 Registers

highway. Optionally sampling of XSIG data is controlled by the active high XSIGM marker.

- 0011 = TCLK: Transmit Clock (Input)
A 2.048/8.192 MHz clock has to be sourced by the system if the internal generated transmit clock (DCO-X) is not used. Optionally this input is used as a synchronization clock for the DCO-X circuitry with a frequency of 2.048 MHz.
- 0100 = XMFB: Transmit Multiframe Begin (Output)
Marks the beginning of every transmit multiframe.
- 0101 = XSIGM: Transmit Signaling Marker (Output)
Marks the time slots which are defined by register TTR(4:1) of every frame on port XDI.
- 0110 = DLX: Data Link Bit Transmit (Output)
Marks the S_a-bits within the data stream on XDI.
- 0111 = XCLK: Transmit Line Clock (Output)
Frequency: 2.048 MHz
- 1000 = XLT: Transmit Line Tristate (Input)
With a high level on this port the transmit lines XL1/2 or XDOP/N are set directly into tristate. This pin function is logically ored with register XPM2.XLT.

Port Configuration 5 (Read/Write)

Value after reset: 00_H

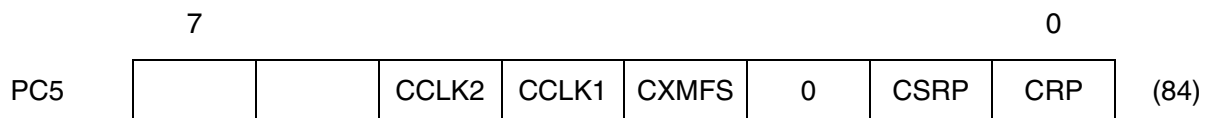

- CCLK2 Configure CLK2 Port**
0 = CLK2 is input
1 = CLK2 is output (only, if DCO-X is active)
- CCLK1 Configure CLK1 Port**
0 = CLK1 is input
1 = CLK1 is output (only, if DCO-R is active)

- CXMFS** **Configure XMFS Port**
 0 = Port XMFS is active low.
 1 = Port XMFS is active high.
- PC5(2)** reserved.
 Must be cleared
- CSRP** **Configure SCLKR Port**
 0 = SCLKR: Input
 1 = SCLKR: Output
- CRP** **Configure RCLK Port**
 0 = RCLK: Input
 1 = RCLK: Output

Global Port Configuration 1 (Read/Write)

Value after reset: 00_H



- CSFP(1:0)** **Configure SEC/FSC Port**
 The FSC pulse is generated if the DCO-R circuitry of the selected channel is active (CMR2.IRSC = 1 or CMR1.RS(1:0) = 10 or 11).
 00 = SEC: Input, active high
 01 = SEC: Output, active high
 10 = FSC: Output, active high
 11 = FSC: Output, active low

Port Configuration 6 (Read/Write)

Value after reset: 00_H

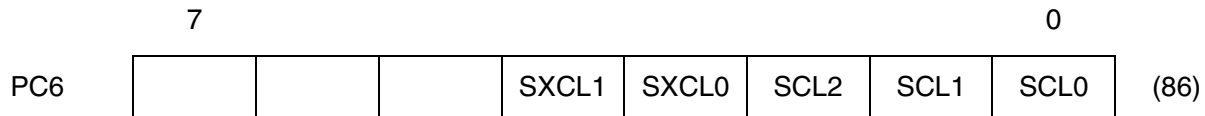

SXCL(1:0) Select Transmit Clock Frequency on Port CLK2

Port CLK2 is the de-jittered DCO-X clock at a frequency of

00 = 2.048 MHz

01 = 4.096 MHz

10 = 8.192 MHz

11 = 16.384 MHz

Note: If DCO-X is not used, no clock is output on pin CLK2 (SIC1.XBS(1:0)=00 and CMR1.DXJA=1; buffer bypass and no jitter attenuation)

SCL(2:0) Select System Clock Frequency on Port CLK1

Port CLK1 is the de-jittered DCO-R clock at a frequency of

000 = 8 kHz

001 = 2.048 MHz

010 = 4.096 MHz

011 = 8.192 MHz

100 = 16.384 MHz

101 to 111 = Not defined

Note: If DCO-R is not active, no clock is output on pin CLK1 (SIC1.RBS(1:0)=11 and CMR1.RS1=0).

Command Register 2 (Write)

Value after reset: 00_H

CMDR2							RSUC		(x87)
-------	--	--	--	--	--	--	------	--	-------

RSUC

Reset Signaling Unit Counter

After setting this bit the SS7 signaling unit counter and error counter are reset. The bit is cleared automatically after execution.

Note: The maximum time between writing to the CMDR2 register and the execution of the command takes 2.5 periods of the current system data rate. Therefore, if the CPU operates with a very high clock rate in comparison with the FALC56's clock, it is recommended that bit SIS.CEC should be checked before writing to the CMDR2 register to avoid any loss of commands.

Command Register 3 (Write)

Value after reset: 00_H

	7							0	
CMDR3	RMC2		XREP2		XHF2	XTF2	XME2	SRES2	(88)

RMC2

Receive Message Complete - HDLC Channel 2

Confirmation from CPU to FALC[®] that the current frame or data block has been fetched following an RPF2 or RME2 interrupt, thus the occupied space in the RFIFO2 can be released.

XREP2

Transmission Repeat - HDLC Channel 2

If XREP2 is set together with XTF2 (write 24H to CMDR3), the FALC[®] repeatedly transmits the contents of the XFIFO2 (1 to 32 bytes) without HDLC framing fully transparently, i.e. without flag, CRC.

The cyclic transmission is stopped with an SRES2 command or by resetting XREP2.

XHF2

Transmit HDLC Frame - HDLC Channel 2

After having written up to 32 bytes to the XFIFO2, this command initiates the transmission of a HDLC frame.

- XTF2 Transmit Transparent Frame - HDLC Channel 2**
Initiates the transmission of a transparent frame without HDLC framing.
- XME2 Transmit Message End - HDLC Channel 2**
Indicates that the data block written last to the XFIFO2 completes the current frame. The FALC[®] can terminate the transmission operation properly by appending the CRC and the closing flag sequence to the data.
- SRES2 Signaling Transmitter Reset - HDLC Channel 2**
The transmitter of the signaling controller is reset. XFIFO2 is cleared of any data and an abort sequence (seven 1s) followed by interframe time fill is transmitted. In response to SRES2 an XPR2 interrupt is generated.
This command can be used by the CPU to abort a frame currently in transmission.

Command Register 4 (Write)

Value after reset: 00_H

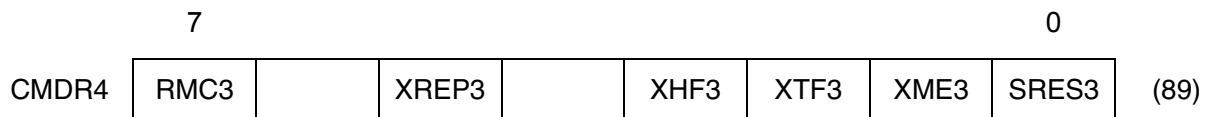

- RMC3 Receive Message Complete - HDLC Channel 3**
Confirmation from CPU to FALC[®] that the current frame or data block has been fetched following an RPF3 or RME3 interrupt, thus the occupied space in the RFIFO3 can be released.
- XREP3 Transmission Repeat - HDLC Channel 3**
If XREP3 is set together with XTF3 (write 24H to CMDR4), the FALC[®] repeatedly transmits the contents of the XFIFO3 (1 to 32 bytes) without HDLC framing fully transparently, i.e. without flag, CRC.
The cyclic transmission is stopped with an SRES3 command or by resetting XREP3.
- XHF3 Transmit HDLC Frame - HDLC Channel 3**
After having written up to 32 bytes to the XFIFO3, this command initiates the transmission of a HDLC frame.

- XTF3** **Transmit Transparent Frame - HDLC Channel 3**
Initiates the transmission of a transparent frame without HDLC framing.
- XME3** **Transmit Message End - HDLC Channel 3**
Indicates that the data block written last to the XFIFO3 completes the current frame. The FALC[®] can terminate the transmission operation properly by appending the CRC and the closing flag sequence to the data.
- SRES3** **Signaling Transmitter Reset - HDLC Channel 3**
The transmitter of the signaling controller is reset. XFIFO3 is cleared of any data and an abort sequence (seven 1s) followed by interframe time fill is transmitted. In response to SRES3 an XPR3 interrupt is generated.
This command can be used by the CPU to abort a frame currently in transmission.

Common Configuration Register 3 (Read/Write)

Value after reset: 00_H

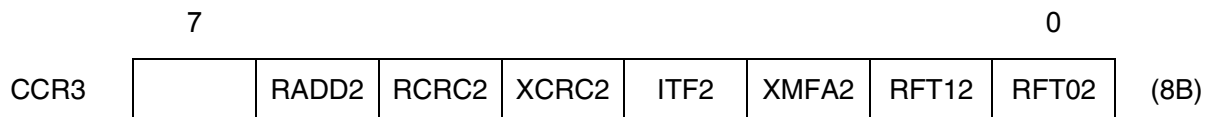

- RADD2** **Receive Address Pushed to RFIFO2**
If this bit is set, the received HDLC channel 2 address information (1 or 2 bytes, depending on the address mode selected via MODE2.MDS02) is pushed to RFIFO2. This function is applicable in non-auto mode and transparent mode 1.
- RCRC2** **Receive CRC ON/OFF - HDLC Channel 2**
Only applicable in non-auto mode.
If this bit is set, the received CRC checksum is written to RFIFO2 (CRC-ITU-T: 2 bytes). The checksum, consisting of the 2 last bytes in the received frame, is followed in the RFIFO2 by the status information byte (contents of register RSIS2). The received CRC checksum will additionally be checked for correctness. If non-auto mode is selected, the limits for “Valid Frame” check are modified.

XCRC2 Transmit CRC ON/OFF - HDLC Channel 2
If this bit is set, the CRC checksum will not be generated internally. It has to be written as the last two bytes in the transmit FIFO (XFIFO2). The transmitted frame is closed automatically with a closing flag.

ITF2 Interframe Time Fill - HDLC Channel 2
Determines the idle (= no data to be sent) state of the transmit data coming from the signaling controller.
0 = Continuous logical "1" is output
1 = Continuous flag sequences are output ("01111110" bit patterns)

XMFA2 Transmit Multiframe Aligned - HDLC Channel 2
Determines the synchronization between the framer and the corresponding signaling controller.
0 = The contents of the XFIFO2 is transmitted without multiframe alignment.
1 = The contents of the XFIFO2 is transmitted multiframe aligned.

RFT12, RFT02 RFIFO2 Threshold Level - HDLC Channel 2
The size of the accessible part of RFIFO2 can be determined by programming these bits. The number of valid bytes after an RPF interrupt is given in the following table:

RFT12	RFT02	Size of Accessible Part of RFIFO2
0	0	32 bytes (default value)
0	1	16 bytes
1	0	4 bytes
1	1	2 bytes

The value of RFT(1:0)2 can be changed dynamically if reception is not running or after the current data block has been read, but before the command CMDR3.RMC2 is issued (interrupt controlled data transfer).

Common Configuration Register 4 (Read/Write)

Value after reset: 00_H

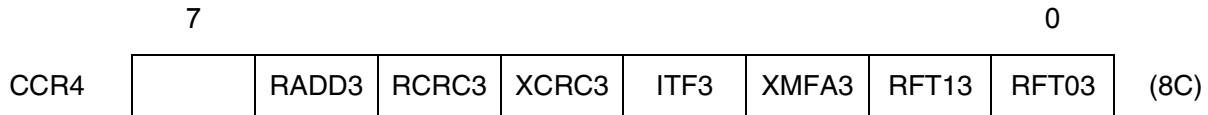

- RADD3 Receive Address Pushed to RFIFO3**
If this bit is set, the received HDLC channel 3 address information (1 or 2 bytes, depending on the address mode selected via MODE3.MDS03) is pushed to RFIFO3. This function is applicable in non-auto mode and transparent mode 1.
- RCRC3 Receive CRC ON/OFF - HDLC Channel 3**
Only applicable in non-auto mode.
If this bit is set, the received CRC checksum is written to RFIFO3 (CRC-ITU-T: 2 bytes). The checksum, consisting of the 2 last bytes in the received frame, is followed in the RFIFO3 by the status information byte (contents of register RSIS3). The received CRC checksum will additionally be checked for correctness. If non-auto mode is selected, the limits for "Valid Frame" check are modified.
- XCRC3 Transmit CRC ON/OFF - HDLC Channel 3**
If this bit is set, the CRC checksum will not be generated internally. It has to be written as the last two bytes in the transmit FIFO (XFIFO3). The transmitted frame is closed automatically with a closing flag.
- ITF3 Interframe Time Fill - HDLC Channel 3**
Determines the idle (= no data to be sent) state of the transmit data coming from the signaling controller.
0 = Continuous logical "1" is output
1 = Continuous flag sequences are output ("01111110" bit patterns)
- XMFA3 Transmit Multiframe Aligned - HDLC Channel 3**
Determines the synchronization between the framer and the corresponding signaling controller.
0 = The contents of the XFIFO3 is transmitted without multiframe alignment.
1 = The contents of the XFIFO3 is transmitted multiframe aligned.

RFT13, RFT03 RFIFO3 Threshold Level - HDLC Channel 3

The size of the accessible part of RFIFO3 can be determined by programming these bits. The number of valid bytes after an RPF interrupt is given in the following table:

RFT13	RFT03	Size of Accessible Part of RFIFO3
0	0	32 bytes (default value)
0	1	16 bytes
1	0	4 bytes
1	1	2 bytes

The value of RFT13/03 can be changed dynamically if reception is not running or after the current data block has been read, but before the command CMDR4.RMC3 is issued (interrupt controlled data transfer).

Common Configuration Register 5 (Read/Write)

Value after reset: 00_H

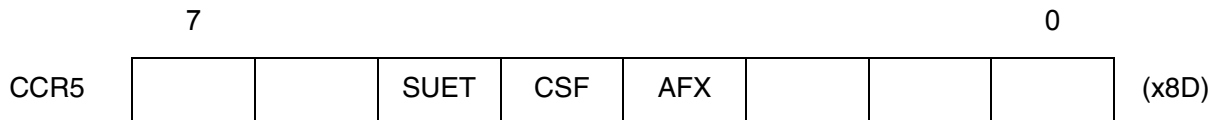

Note: These bits are only valid, if SS7 mode of HDLC channel 1 is selected.

SUET Signaling Unit Error Threshold

Defines the number of signaling units received in error that will cause an error rate high indication (ISR1.SUEX).

- 0 = Threshold 64 errored signaling units
- 1 = Threshold 32 errored signaling units

CSF Compare Status Field

If the status fields of consecutive LSSUs are equal, only the first is stored and every following is ignored.

- 0 = Compare disabled.
- 1 = Compare enabled.

AFX Automatic FISU Transmission

After the contents of the transmit FIFO (XFIFO) has been transmitted completely, FISUs are transmitted automatically. These FISUs contain the FSN and BSO of the last transmitted signaling unit.

0 = Automatic FISU transmission disabled.

1 = Automatic FISU transmission enabled.

Mode Register 2 (Read/Write)

Value after reset: 00_H

	7					0	
MODE2	MDS22	MDS21	MDS20		HRAC2	DIV2	

(8E)

MDS2(2:0) Mode Select - HDLC Channel 2

The operating mode of the HDLC controller is selected.

000 =Reserved

001 =Reserved

010 =One-byte address comparison mode (RAL1, 2)

011 =Two-byte address comparison mode (RAH1, 2 and RAL1, 2)

100 =No address comparison

101 =One-byte address comparison mode (RAH1, 2)

110 =Reserved

111 =No HDLC framing mode 1

HRAC2 Receiver Active - HDLC Channel 2

Switches the HDLC receiver to operational or inoperational state.

0 = Receiver inactive

1 = Receiver active

DIV2 Data Inversion - HDLC Channel 2

Setting this bit will invert the internal generated HDLC data stream.

0 = Normal operation, HDLC data stream not inverted

1 = HDLC data stream inverted

Mode Register 3 (Read/Write)

Value after reset: 00_H

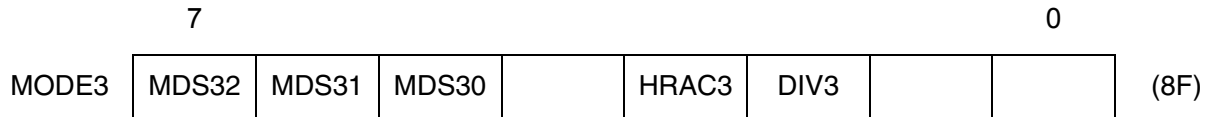

MDS3(2:0) Mode Select - HDLC Channel 3

The operating mode of the HDLC controller is selected.

000 =Reserved

001 =Reserved

010 =One-byte address comparison mode (RAL1, 2)

011 =Two-byte address comparison mode (RAH1, 2 and RAL1, 2)

100 =No address comparison

101 =One-byte address comparison mode (RAH1, 2)

110 =Reserved

111 =No HDLC framing mode 1

HRAC3 Receiver Active - HDLC Channel 3

Switches the HDLC receiver to operational or inoperational state.

0 = Receiver inactive

1 = Receiver active

DIV3 Data Inversion - HDLC Channel 3

Setting this bit will invert the internal generated HDLC data stream.

0 = Normal operation, HDLC data stream not inverted

1 = HDLC data stream inverted

Global Clock Mode Register 1 (Read/Write)

Value after reset: 00_H

	7							0	
GCM1	PHD_E1 7	PHD_E1 6	PHD_E1 5	PHD_E1 4	PHD_E1 3	PHD_E1 2	PHD_E1 1	PHD_E1 0	(92)

PHD_E1(7:0) Frequency Adjust for E1

For details see calculation formulas below.

Global Clock Mode Register 2 (Read/Write)

Value after reset: 00_H

	7						0		
GCM2	DVM_E1 2	DVM_E1 1	DVM_E1 0	VFREQ_ EN	PHD_E1 11	PHD_E1 10	PHD_E1 9	PHD_E1 8	(93)

PHD_E1(8:11) Frequency Adjust for E1

For details see calculation formulas below.

VFREQ_EN Variable Frequency Enable

0 = Fixed clock frequency of 2.048 (E1) or 1.544 MHz (T1/J1)

1 = Variable master clock frequency

DVM_E1(0:2) Divider Mode for E1

000 = Not valid

001 = Divide by DIV_E1 = 3

010 = Divide by DIV_E1 = 4 1/6

011 = Divide by DIV_E1 = 4

100 = Divide by DIV_E1 = 5.5

101 = Divide by DIV_E1 = 5 1/3

110 = Divide by DIV_E1 = 5 2/3

111 = Not valid

Global Clock Mode Register 3 (Read/Write)

Value after reset: 00_H

	7							0	
GCM3	PHD_T1 7	PHD_T1 6	PHD_T1 5	PHD_T1 4	PHD_T1 3	PHD_T1 2	PHD_T1 1	PHD_T1 0	(94)

PHD_T1(7:0) Frequency Adjust for T1

For details see calculation formulas below.

Global Clock Mode Register 4 (Read/Write)

Value after reset: 00_H

	7								0	
GCM4	DVM_T1 2	DVM_T1 1	DVM_T1 0	0	PHD_T1 11	PHD_T1 10	PHD_T1 9	PHD_T1 8	(95)	

PHD_T1(8:11) Frequency Adjust for T1

For details see calculation formulas below.

DVM_T1(0:2) Divider Mode for T1

- 000 = Not valid
- 001 = Divide by DIV_T1 = 3
- 010 = Divide by DIV_T1 = 4 1/6
- 011 = Divide by DIV_T1 = 4
- 100 = Divide by DIV_T1 = 5.5
- 101 = Divide by DIV_T1 = 5 1/3
- 110 = Divide by DIV_T1 = 5 2/3
- 111 = Not valid

GCM4.4 Reserved

Must be cleared.

Global Clock Mode Register 5 (Read/Write)

Value after reset: 00_H

	7							0	
GCM5	MCLK_ LOW			PLL_M 4	PLL_M 3	PLL_M 2	PLL_M 1	PLL_M 0	(96)

MCLK_LOW Master Clock Range Low

0 = Master clock frequency divided by (PLL_M+1) is greater than or equal 1.5 MHz

1 = Master clock frequency divided by (PLL_M+1) is less than 1.5 MHz

PLL_M(4:0) PLL Dividing Factor M

For details see calculation formulas below.

Note: Write operations to GCM5 initiate a PLL reset (see below).

Global Clock Mode Register 6 (Read/Write)

Value after reset: 00_H

	7							0	
GCM6				PLL_N 4	PLL_N 3	PLL_N 2	PLL_N 1	PLL_N 0	(97)

PLL_N(4:0) PLL Dividing Factor N

For details see calculation formulas below.

Note: Write operations to GCM6 initiate a PLL reset (see below).

Flexible Clock Mode Settings

If flexible master clock mode is used (VFREQ_EN = 1), the according register settings can be calculated as follows (a windows-based program for automatic calculation is available, see [Chapter 13.3](#) on [page 481](#)). For some of the standard frequencies see the table below.

1. PLL_M and PLL_N must fulfill the equations:

a. $1.5 \text{ MHz} \leq f_{\text{MCLK}} / (\text{PLL_M}+1) \leq 2.048 \text{ MHz}$

b. If (a.) is not possible, set MCLK_LOW and fulfill
 $1.02 \text{ MHz} \leq f_{\text{MCLK}} / (\text{PLL_M}+1) \leq 1.5 \text{ MHz}$

c. $65 \text{ MHz} \leq f_{\text{MCLK}} \times (2 \times \text{PLL_N}+2) / (\text{PLL_M}+1) \leq 69.7 \text{ MHz}$
 (as high as possible within this range)

2. Selection of dividing mode to best fulfill:

$$f_{\text{outE1}} = (f_{\text{MCLK}} \times (2 \times \text{PLL_N}+2) / (\text{PLL_M}+1)) / \text{DIV_E1} \text{ (target E1: 16.384 MHz)}$$

$$f_{\text{outT1}} = (f_{\text{MCLK}} \times (2 \times \text{PLL_N}+2) / (\text{PLL_M}+1)) / \text{DIV_T1} \text{ (target T1: 12.352 MHz)}$$

Though the target frequency might not be met directly, the dividing mode has to be selected to reach a frequency, which is as near as possible to the target frequency.

3. Calculation of correction value (frequency mismatch correction)

$$\text{PHD_E1} = 6 \times 4096 \times [\text{DIV_E1} - (2 \times \text{PLL_N}+2) / (\text{PLL_M}+1) \times (f_{\text{MCLK}} / 16.384 \text{ MHz})]$$

$$\text{PHD_T1} = 6 \times 4096 \times [\text{DIV_T1} - (2 \times \text{PLL_N}+2) / (\text{PLL_M}+1) \times (f_{\text{MCLK}} / 12.352 \text{ MHz})]$$

The result of these equations will be in the range of -2048 to +2047. Negative values are represented in 2s-complement format (e.g. $-2000_{\text{D}} = 830_{\text{H}}$; $+2000_{\text{D}} = 7D0_{\text{H}}$).

Table 60 Clock Mode Register Settings for E1 or T1/J1

f_{MCLK} [MHz]	GCM1	GCM2	GCM3	GCM4	GCM5	GCM6
1.544	F0 _H	51 _H	00 _H	80 _H	00 _H	15 _H
2.048	00 _H	58 _H	D2 _H	C2 _H	00 _H	10 _H
8.192	00 _H	58 _H	D2 _H	C2 _H	03 _H	10 _H
10.000	90 _H	51 _H	81 _H	8F _H	04 _H	10 _H
12.352	F0 _H	51 _H	00 _H	80 _H	07 _H	15 _H

Transmit FIFO 2 (Write)

Value after reset: 00_H

	7	0	
XFIFO2	XF7	XF0	(x9C)
XFIFO2	XF15	XF8	(x9D)

XF(15:0) Transmit FIFO for HDLC Channel 2
The function is equivalent to XFIFO.

Transmit FIFO 3 (Write)

Value after reset: 00_H

	7	0	
XFIFO3	XF7	XF0	(x9E)
XFIFO3	XF15	XF8	(x9F)

XF(15:0) Transmit FIFO for HDLC Channel 3
The function is equivalent to XFIFO.

Time Slot Even/Odd Select (Read/Write)

Value after reset: 00_H

	7	0	
TSEO			EO31 EO30 EO21 EO20 EO11 EO10 (A0)

HDLC protocol data can be sent in even, odd or both frames of a multiframe. Even frames are frame number 2, 4, and so on, odd frames are frame number 1, 3, and so on. The selection refers to receive and transmit direction as well. Each multiframe starts with an odd frame and ends with an even frame. By default all frames are used for HDLC reception and transmission.

Note: The different HDLC channels have to be configured to use different time slots, bit positions or frames.

EO1(1:0) Even/Odd frame selection HDLC Channel 1
Channel 1 HDLC protocol data can be sent in even, odd or both frames of a multiframe.
00 = Even and odd frames
01 = Odd frames only
10 = Even frames only
11 = Undefined

EO2(1:0) Even/Odd frame selection HDLC Channel 2
Channel 2 HDLC protocol data can be sent in even, odd or both frames of a multiframe.
00 = Even and odd frames
01 = Odd frames only
10 = Even frames only
11 = Undefined

EO3(1:0) Even/Odd frame selection HDLC Channel 3
Channel 3 HDLC protocol data can be sent in even, odd or both frames of a multiframe.
00 = Even and odd frames
01 = Odd frames only
10 = Even frames only
11 = Undefined

Time Slot Bit Select 1 (Read/Write)

Value after reset: FF_H

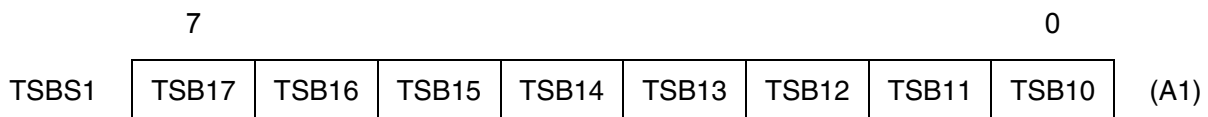

TSB1(7:0) Time Slot Bit Selection - HDLC Channel 1
Only bits selected by this register are used for HDLC channel 1 in selected time slots. Time slot selection is done by setting the appropriate bits in registers TTR(4:1) and RTR(4:1) independently for receive and transmit direction. Bit selection is common to receive and transmit direction. By default all bit positions within the selected time slot(s) are enabled.
0 = Bit position x in selected time slot(s) is not used for HDLC channel 1 reception and transmission.

1 = Bit position x in selected time slot(s) is used for HDLC channel 1 reception and transmission.

Time Slot Bit Select 2 (Read/Write)

Value after reset: FF_H

	7							0	
TSBS2	TSB27	TSB26	TSB25	TSB24	TSB23	TSB22	TSB21	TSB20	(A2)

TSB2(7:0)

Time Slot Bit Selection - HDLC Channel 2

Only bits selected by this register are used for HDLC channel 2 in selected time slots. Time slot selection is done by setting the appropriate bits in register TSS2. Bit selection is common to receive and transmit direction. By default all bit positions within the selected time slot are enabled.

0 = Bit position x in selected time slot(s) is not used for HDLC channel 2 reception and transmission.

1 = Bit position x in selected time slot(s) is used for HDLC channel 2 reception and transmission.

Time Slot Bit Select 3 (Read/Write)

Value after reset: FF_H

	7							0	
TSBS3	TSB37	TSB36	TSB35	TSB34	TSB33	TSB32	TSB31	TSB30	(A3)

TSB3(7:0)

Time Slot Bit Selection - HDLC Channel 3

Only bits selected by this register are used for HDLC channel 3 in selected time slots. Time slot selection is done by setting the appropriate bits in register TSS3. Bit selection is common to receive and transmit direction. By default all bit positions within the selected time slot are enabled.

0 = Bit position x in selected time slot(s) is not used for HDLC channel 3 reception and transmission.

1 = Bit position x in selected time slot(s) is used for HDLC channel 3 reception and transmission.

Test Pattern Control Register 0 (Read/Write)

Value after reset: 00_H

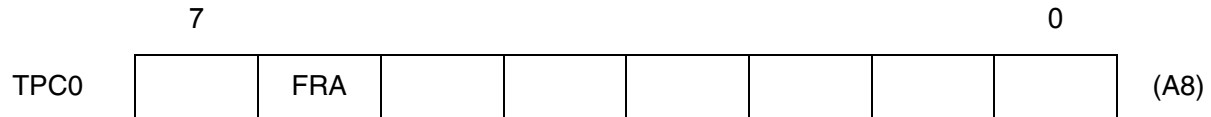

FRA

Framed/Unframed Selection

- 0 = PRBS is generated/monitored unframed.
 Framing information is overwritten by the generator.
- 1 = PRBS is generated/monitored framed.
 Time slot 0 is not overwritten by the generator and not observed by the monitor.

9.3 E1 Status Register Addresses
Table 61 E1 Status Register Address Arrangement

Address	Register	Type	Comment	Page
00	RFIFO	R	Receive FIFO	289
01	RFIFO	R	Receive FIFO	289
49	RBD	R	Receive Buffer Delay	289
4A	VSTR	R	Version Status Register	290
4B	RES	R	Receive Equalizer Status	290
4C	FRS0	R	Framer Receive Status 0	291
4D	FRS1	R	Framer Receive Status 1	294
4E	RSW	R	Receive Service Word	295
4F	RSP	R	Receive Spare Bits	296
50	FECL	R	Framing Error Counter Low	298
51	FECH	R	Framing Error Counter High	298
52	CVCL	R	Code Violation Counter Low	299
53	CVCH	R	Code Violation Counter High	299
54	CEC1L	R	CRC Error Counter 1 Low	300
55	CEC1H	R	CRC Error Counter 1 High	300
56	EBCL	R	E-Bit Error Counter Low	301
57	EBCH	R	E-Bit Error Counter High	301
58	CEC2L	R	CRC Error Counter 2 Low	302
59	CEC2H	R	CRC Error Counter 2 High	302
5A	CEC3L	R	CRC Error Counter 3 Low	303
5B	CEC3H	R	CRC Error Counter 3 High	303
5C	RSA4	R	Receive S _a 4-Bit Register	304
5D	RSA5	R	Receive S _a 5-Bit Register	304
5E	RSA6	R	Receive S _a 6-Bit Register	304
5F	RSA7	R	Receive S _a 7-Bit Register	304
60	RSA8	R	Receive S _a 8-Bit Register	304
61	RSA6S	R	Receive S _a 6-Bit Status Register	305
62	RSP1	R	Receive Signaling Pointer 1	306
63	RSP2	R	Receive Signaling Pointer 2	306

Table 61 E1 Status Register Address Arrangement (cont'd)

Address	Register	Type	Comment	Page
64	SIS	R	Signaling Status Register	307
65	RSIS	R	Receive Signaling Status Register	308
66	RBCL	R	Receive Byte Control Low	310
67	RBCH	R	Receive Byte Control High	310
68	ISR0	R	Interrupt Status Register 0	310
69	ISR1	R	Interrupt Status Register 1	312
6A	ISR2	R	Interrupt Status Register 2	314
6B	ISR3	R	Interrupt Status Register 3	316
6C	ISR4	R	Interrupt Status Register 4	317
6D	ISR5	R	Interrupt Status Register 5	319
6E	GIS	R	Global Interrupt Status	321
70	RS1	R	Receive CAS Register 1	322
71	RS2	R	Receive CAS Register 2	322
72	RS3	R	Receive CAS Register 3	322
73	RS4	R	Receive CAS Register 4	322
74	RS5	R	Receive CAS Register 5	322
75	RS6	R	Receive CAS Register 6	322
76	RS7	R	Receive CAS Register 7	322
77	RS8	R	Receive CAS Register 8	322
78	RS9	R	Receive CAS Register 9	322
79	RS10	R	Receive CAS Register 10	322
7A	RS11	R	Receive CAS Register 11	322
7B	RS12	R	Receive CAS Register 12	322
7C	RS13	R	Receive CAS Register 13	322
7D	RS14	R	Receive CAS Register 14	322
7E	RS15	R	Receive CAS Register 15	322
7F	RS16	R	Receive CAS Register 16	322
90	RBC2	R	Receive Byte Count Register 2	323
91	RBC3	R	Receive Byte Count Register 3	323
98	SIS2	R	Signaling Status Register 2	323

Table 61 E1 Status Register Address Arrangement (cont'd)

Address	Register	Type	Comment	Page
99	RSIS2	R	Receive Signaling Status Register 2	325
9A	SIS3	R	Signaling Status Register 3	326
9B	RSIS3	R	Receive Signaling Status Register 3	327
9C	RFIFO2	R	Receive FIFO 2	329
9D	RFIFO2	R	Receive FIFO 2	329
9E	RFIFO3	R	Receive FIFO 3	329
9F	RFIFO3	R	Receive FIFO 3	329
EC	WID	R	Identification Register	329

9.4 Detailed Description of E1 Status Registers

Receive FIFO - HDLC Channel 1 (Read)

	7		0	
RFIFO	RF7		RF0	(00)
RFIFO	RF15		RF8	(01)

Reading data from RFIFO of HDLC channel 1 can be done in an 8-bit (byte) or 16-bit (word) access depending on the selected bus interface mode. The LSB is received first from the serial interface.

The size of the accessible part of RFIFO is determined by programming the bits CCR1.RFT(1:0) (RFIFO threshold level). It can be reduced from 32 bytes (reset value) down to 2 bytes (four values: 32, 16, 4, 2 bytes).

Data Transfer

Up to 32 bytes/16 words of received data can be read from the RFIFO following an RPF or an RME interrupt.

RPF Interrupt: A fixed number of bytes/words to be read (32, 16, 4, 2 bytes). The message is not yet complete.

RME Interrupt: The message is completely received. The number of valid bytes is determined by reading the RBCL, RBCH registers.

RFIFO is released by issuing the RMC (**R**ecieve **M**essage **C**omplete) command.

Receive Buffer Delay (Read)

	7		0					
RBD		RBD5	RBD4	RBD3	RBD2	RBD1	RBD0	(49)

RBD(5:0) Receive Elastic Buffer Delay

These bits inform the user about the current delay (in time slots) through the receive elastic buffer. The delay is updated every 512 or 256 bits (SIC1.RBS(1:0)). Before reading this register the user has to set bit DEC.DRBD in order to halt the current value of this register. After reading RBD updating of this register is enabled. Not valid if the receive buffer is bypassed.

000000 = Delay < 1 time slot

...

111111 = Delay > 63 time slots

Version Status Register (Read)

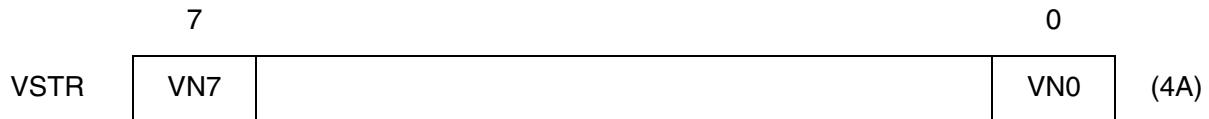

VN(7:0) Version Number of Chip
00_H = Version 1.2

Receive Equalizer Status (Read)

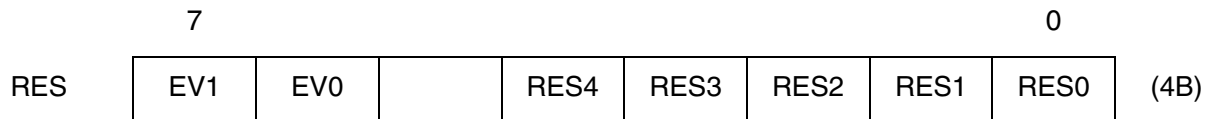

EV(1:0) Equalizer Status Valid
These bits informs the user about the current state of the receive equalization network. Only valid if LIM1.EQON is set.
00 = Equalizer status not valid, still adapting
01 = Equalizer status valid
10 = Equalizer status not valid
11 = Equalizer status valid but high noise floor

RES(4:0) Receive Equalizer Status
The current line attenuation status in steps of about 1.7 dB are displayed in these bits. Only valid if bits EV(1:0) = 01 and LIM1.EQON = 1. Accuracy: ± 2 digits, based on temperature influence and noise amplitude variations.
00000 = Minimum attenuation: 0 dB
...
11001 = Maximum attenuation: -43 dB

Framer Receive Status Register 0 (Read)

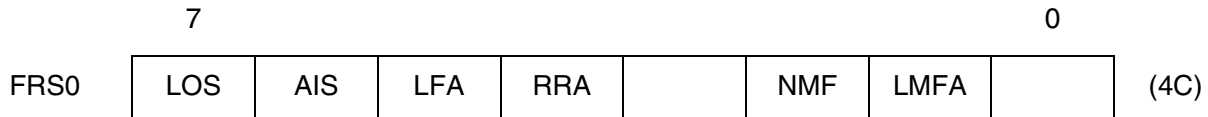

LOS

Loss-of-Signal

Detection:

This bit is set when the incoming signal has “no transitions” (analog interface) or logical zeros (digital interface) in a time interval of T consecutive pulses, where T is programmable by register PCD.

Total account of consecutive pulses: $16 < T < 4096$.

Analog interface: The receive signal level where “no transition” is declared is defined by the programmed value of LIM1.RIL(2:0).

Recovery:

Analog interface: The bit is reset in short-haul mode when the incoming signal has transitions with signal levels greater than the programmed receive input level (LIM1.RIL(2:0)) for at least M pulse periods defined by register PCR in the PCD time interval. In long-haul mode additionally bit RES.6 must be set for at least 250µsec.

Digital interface: The bit is reset when the incoming data stream contains at least M ones defined by register PCR in the PCD time interval.

With the rising edge of this bit an interrupt status bit (ISR2.LOS) is set. The bit is also set during alarm simulation and reset, if FMR0.SIM is cleared and no alarm condition exists.

AIS

Alarm Indication Signal

The function of this bit is determined by FMR0.ALM.

FMR0.ALM = 0: This bit is set when two or less zeros in the received bit stream are detected in a time interval of 250 µs and the FALC56 is in asynchronous state (FRS0.LFA = 1). The bit is reset when no alarm condition is detected (according to ETSI standard).

FMR0.ALM = 1: This bit is set when the incoming signal has two or less Zeros in each of two consecutive double frame period (512 bits). This bit is cleared when each of two consecutive doubleframe periods contain three or more zeros or when the frame alignment signal FAS has been found. (ITU-T G.775)

The bit is also set during alarm simulation and reset if FMR0.SIM is cleared and no alarm condition exists.

With the rising edge of this bit an interrupt status bit (ISR2.AIS) is set.

LFA**Loss of Frame Alignment**

This bit is set after detecting 3 or 4 consecutive incorrect FAS words or 3 or 4 consecutive incorrect service words (can be disabled). With the rising edge of this bit an interrupt status bit (ISR2.LFA) is set. The specification of the loss of synchronization conditions is done by bits RC0.SWD and RC0.ASY4. After loss of synchronization, the frame aligner resynchronizes automatically.

The following conditions have to be detected to regain synchronous state:

- The presence of the correct FAS word in frame n.
- The presence of the correct service word (bit 2 = 1) in frame n+1.
- For a second time the presence of a correct FAS word in frame n+2.

The bit is cleared when synchronization has been regained (directly after the second correct FAS word of the procedure described above has been received).

If the CRC-multiframe structure is enabled by setting bit FMR2.RFS1, multiframe alignment is assumed to be lost if pulseframe synchronization has been lost. The resynchronization procedure for multiframe alignment starts after the bit FRS0.LFA has been cleared.

Multiframe alignment has been regained if two consecutive CRC-multiframes have been received without a framing error (refer to FRS0.LMFA).

The bit is set during alarm simulation and reset if FMR0.SIM is cleared and no alarm condition exists.

If bit FRS0.LFA is cleared a loss of frame alignment recovery interrupt status ISR2.FAR is generated.

RRA**Receive Remote Alarm**

Set if bit 3 of the received service word is set. An alarm interrupt status ISR2.RA can be generated if the alarm condition is detected.

FRS0.RRA is cleared if no alarm is detected. At the same time a remote alarm recovery interrupt status ISR2.RAR is generated.

The bit RSW.RRA has the same function.

Both status and interrupt status bits are set during alarm simulation.

NMF **No Multiframe Alignment Found**

This bit is only valid if the CRC4 interworking is selected (FMR2.RFS(1:0) = 11). Set if the multiframe pattern is not detected in a time interval of 400 ms after the framer has reached the doubleframe synchronous state. The receiver is then automatically switched to doubleframe format.

This bit is reset if the basic framing has been lost.

LMFA **Loss of Multiframe Alignment**

Not used in doubleframe format (FMR2.RFS1 = 0). In this case LMFA is set.

In CRC-multiframe mode (FMR2.RFS1 = 1), this bit is set

- if force resynchronization is initiated by setting bit FMR0.FRS, or
- if multiframe force resynchronization is initiated by setting bit FMR1.MFCS, or
- if pulseframe alignment has been lost (FRS0.LFA).

It is reset if two CRC-multiframes have been received at an interval of $n \times 2$ ms ($n = 1, 2, 3$ and so forth) without a framing error.

If bit FRS0.LMFA is cleared a loss of multiframe alignment recovery interrupt status ISR2.MFAR is generated.

Framer Receive Status Register 1 (Read)

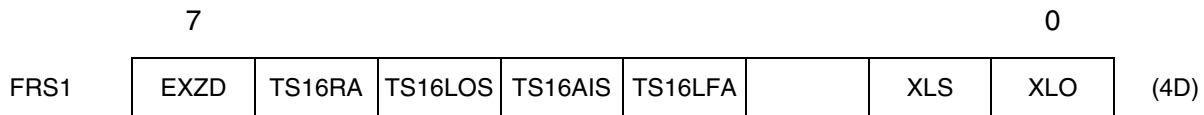

- EXZD** **Excessive Zeros Detected**
 Significant only, if excessive zero detection has been enabled (FMR0.EXZE = 1). Set after detection of more than 3 (HDB3 code) or 15 (AMI code) contiguous zeros in the received data stream. This bit is cleared on read.
- TS16RA** **Receive Time Slot 16 Remote Alarm**
 This bit contains the actual information of the received remote alarm bit RS1.2 in time slot 16. Setting and resetting of this bit causes an interrupt status change ISR3.RA16.
- TS16LOS** **Receive Time Slot 16 Loss-of-Signal**
 This bit is set if the incoming TS16 data stream contains always zeros for at least 16 contiguously received time slots. A one in a time slot 16 resets this bit.
- TS16AIS** **Receive Time Slot 16 Alarm Indication Signal**
 The detection of the alarm indication signal in time slot 16 is according to ITU-T G.775.
 This bit is set if the incoming TS16 contains less than 4 zeros in each of two consecutive TS16 multiframe periods. This bit is cleared if two consecutive received CAS multiframe periods contains more than 3 zeros or the multiframe pattern was found in each of them. This bit is cleared if TS0 synchronization is lost.
- TS16LFA** **Receive Time Slot 16 Loss of Multiframe Alignment**
 0 = The CAS controller is in synchronous state after frame alignment is accomplished.
 1 = This bit is set if the framing pattern "0000" in 2 consecutive CAS multiframes were not found or in all TS16 of the preceding multiframe all bits were reset. An interrupt ISR3.LMFA16 is generated.

XLS

Transmit Line Short

Significant only if the ternary line interface is selected by LIM1.DRS = 0.

- 0 = Normal operation. No short is detected.
- 1 = The XL1 and XL2 are shortened for at least 3 pulses. As a reaction of the short the pins XL1 and XL2 are automatically forced into a high-impedance state if bit XPM2.DAXLT is reset. After 128 consecutive pulse periods the outputs XL1/2 are activated again and the internal transmit current limiter is checked. If a short between XL1/2 is still further active the outputs XL1/2 are in high-impedance state again. When the short disappears pins XL1/2 are activated automatically and this bit is reset. With any change of this bit an interrupt ISR1.XLSC is generated. In case of XPM2.XLT is set this bit is frozen.

XLO

Transmit Line Open

- 0 = Normal operation
- 1 = This bit is set if at least 32 consecutive zeros were sent on pins XL1/XL2 or XDOP/XDON. This bit is reset with the first transmitted pulse. With the rising edge of this bit an interrupt ISR1.XLSC is set. In case of XPM2.XLT is set this bit is frozen.

Receive Service Word Pulseframe (Read)

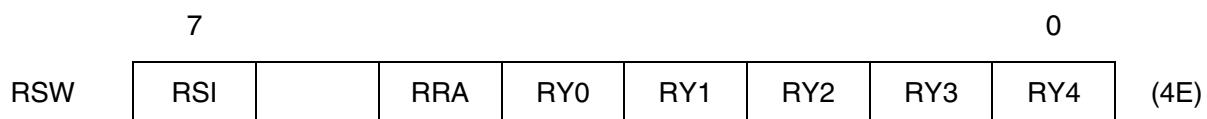

RSI

Receive Spare Bit for International Use

First bit of the received service word. It is fixed to one if CRC-multiframe mode is enabled.

RRA

Receive Remote Alarm

Equivalent to bit FRS0.RRA.

RY(4:0)

Receive Spare Bits for National Use (Y-Bits, S_n-Bits, S_a-Bits)

Receive Spare Bits/Additional Status (Read)

	7							0	
RSP	SI1	SI2		LLBDD	LLBAD	RSIF	RS13	RS15	(4F)

SI(2:1)

Submultiframe Error Indication 1, 2

Not valid if doubleframe format is enabled. In this case, both bits are set.

When using CRC-multiframe format these bits are set to

0 = If multiframe alignment has been lost, or if the last multiframe has been received with CRC error(s).

SI1 flags a CRC error in last submultiframe 1, SI2 flags a CRC error in last submultiframe 2.

1 = If at multiframe synchronous state last assigned submultiframe has been received without a CRC error.

Both flags are updated with the beginning of every received CRC multiframe.

If automatic transmission of submultiframe status is enabled by setting bit XSP.AXS, above status information is inserted automatically in S_i -bit position of every outgoing CRC multiframe (under the condition that time slot 0 transparent modes are both disabled):

SI1 → S_i -bit of frame 13, SI2 → S_i -bit of frame 15.

LLBDD

Line Loop-Back Deactivation Signal Detected

This bit is set in case of the LLB deactivate signal is detected and then received over a period of more than 25 ms with a bit error rate less than 10^{-2} . The bit remains set as long as the bit error rate does not exceed 10^{-2} .

If framing is aligned, the time slot 0 is not taken into account for the error rate calculation.

Any change of this bit causes an LLBSC interrupt.

LLBAD

Line Loop-Back Activation Signal Detected

Depending on bit LCR1.EPRM the source of this status bit changed.

LCR1.EPRM = 0: This bit is set in case of the LLB activate signal is detected and then received over a period of more than 25 ms with a bit error rate less than 10^{-2} . The bit remains set as long as the bit error rate does not exceed 10^{-2} .

If framing is aligned, the time slot 0 is not taken into account for the error rate calculation.

Any change of this bit causes an LLBSC interrupt.

PRBS Status

LCR1.EPRM = 1: The current status of the PRBS synchronizer is indicated in this bit. It is set high if the synchronous state is reached even in the presence of a bit error rate of 10^{-1} . A data stream containing all zeros or all ones with/without framing bits is also a valid pseudo-random binary sequence.

- | | |
|-------------|---|
| RSIF | Receive Spare Bit for International Use (FAS Word)
First bit in FAS-word. Used only in doubleframe format, otherwise fixed to "1". |
| RS13 | Receive Spare Bit (Frame 13, CRC Multiframe)
First bit in service word of frame 13. Significant only in CRC-multiframe format, otherwise fixed to "0". This bit is updated with beginning of every received CRC multiframe. |
| RS15 | Receive Spare Bit (Frame 15, CRC Multiframe)
First bit in service word of frame 15. Significant only in CRC-multiframe format, otherwise fixed to "0". This bit is updated with beginning of every received CRC multiframe. |

Framing Error Counter (Read)

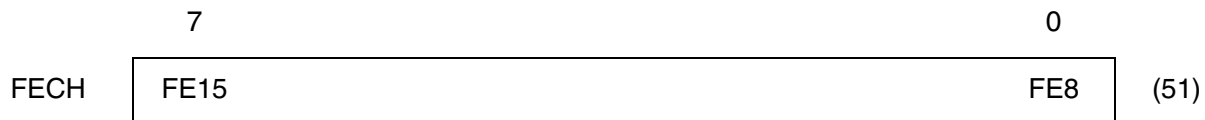
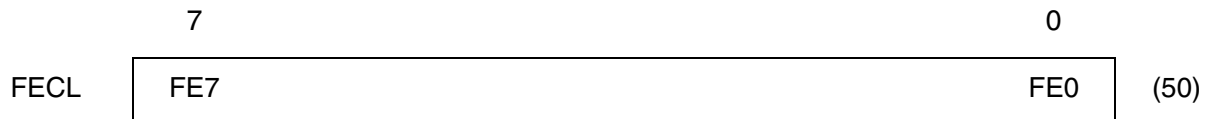

FE(15:0)

Framing Errors

This 16-bit counter is incremented when a FAS word has been received with an error.

Framing errors are counted during basic frame synchronous state only (but even if multiframe synchronous state is not reached yet). During alarm simulation, the counter is incremented every 250 μs up to its saturation. The error counter does not roll over.

Clearing and updating the counter is done according to bit FMR1.ECM.

If this bit is reset the error counter is permanently updated in the buffer. For correct read access of the error counter bit DEC.DFEC has to be set. With the rising edge of this bit updating the buffer is stopped and the error counter is reset. Bit DEC.DFEC is reset automatically with reading the error counter high byte.

If FMR1.ECM is set every second (interrupt ISR3.SEC) the error counter is latched and then automatically reset. The latched error counter state should be read within the next second.

Code Violation Counter (Read)

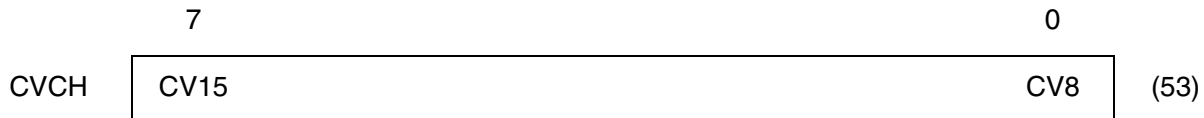
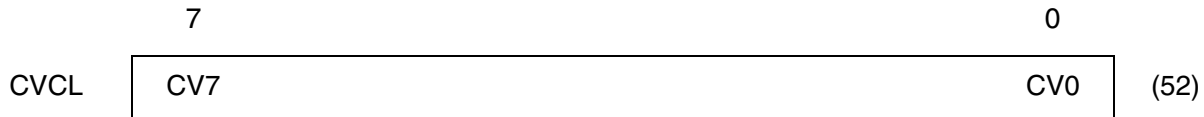

CV(15:0)

Code Violations

No function if NRZ code has been enabled.

If the HDB3 or the CMI code with HDB3-precoding is selected, the 16-bit counter is incremented when violations of the HDB3 code are detected. The error detection mode is determined by programming the bit FMR0.EXTD.

If simple AMI coding is enabled (FMR0.RC0/1 = 10) all bipolar violations are counted. The error counter does not roll over.

During alarm simulation, the counter is incremented every four bits received up to its saturation.

Clearing and updating the counter is done according to bit FMR1.ECM.

If this bit is reset the error counter is permanently updated in the buffer. For correct read access of the error counter bit DEC.DCVC has to be set. With the rising edge of this bit updating the buffer is stopped and the error counter is reset. Bit DEC.DCVC is reset automatically with reading the error counter high byte.

If FMR1.ECM is set every second (interrupt ISR3.SEC) the error counter is latched and then automatically reset. The latched error counter state should be read within the next second.

CRC Error Counter 1 (Read)

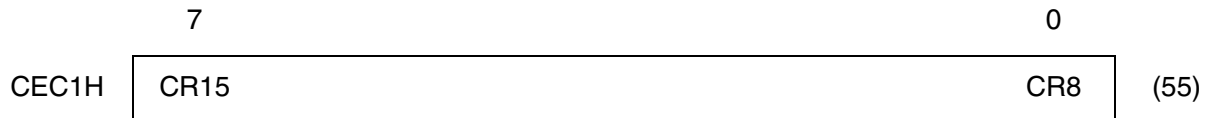
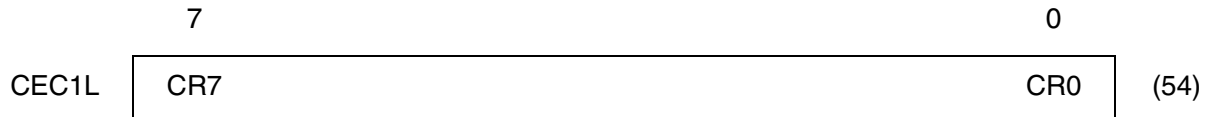

CR(15:0)

CRC Errors

No function if doubleframe format is selected.

In CRC-multiframe mode, the 16-bit counter is incremented when a CRC-submultiframe has been received with a CRC error. CRC errors are not counted during asynchronous state. The error counter does not roll over.

During alarm simulation, the counter is incremented once per submultiframe up to its saturation.

Clearing and updating the counter is done according to bit FMR1.ECM.

If this bit is reset the error counter is permanently updated in the buffer. For correct read access of the error counter bit DEC.DCEC1 has to be set. With the rising edge of this bit updating the buffer is stopped and the error counter is reset. Bit DEC.DCEC1 is reset automatically with reading the error counter high byte.

If FMR1.ECM is set every second (interrupt ISR3.SEC) the error counter is latched and then automatically reset. The latched error counter state should be read within the next second.

E-Bit Error Counter (Read)

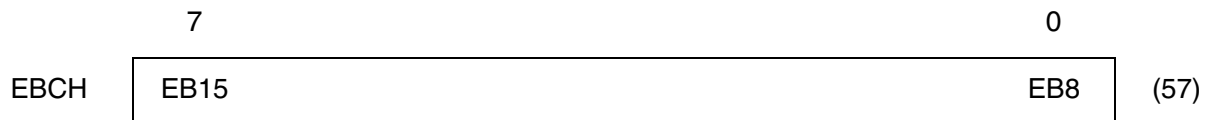
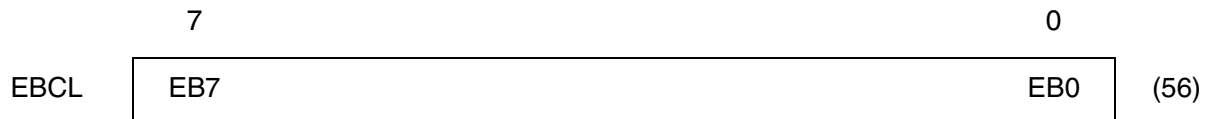

EB(15:0)

E-Bit Errors

If doubleframe format is selected, FEBEH/L has no function. If CRC-multiframe mode is enabled, FEBEH/L works as submultiframe error indication counter (16 bits) which counts zeros in S_i -bit position of frame 13 and 15 of every received CRC multiframe. The error counter does not roll over.

During alarm simulation, the counter is incremented once per submultiframe up to its saturation.

Clearing and updating the counter is done according to bit FMR1.ECM.

If this bit is reset the error counter is permanently updated in the buffer. For correct read access of the error counter bit DEC.DEBC has to be set. With the rising edge of this bit updating the buffer is stopped and the error counter is reset. Bit DEC.DEBC is reset automatically with reading the error counter high byte.

If FMR1.ECM is set every second (interrupt ISR3.SEC) the error counter is latched and then automatically reset. The latched error counter state should be read within the next second.

CRC Error Counter 2 (Read)

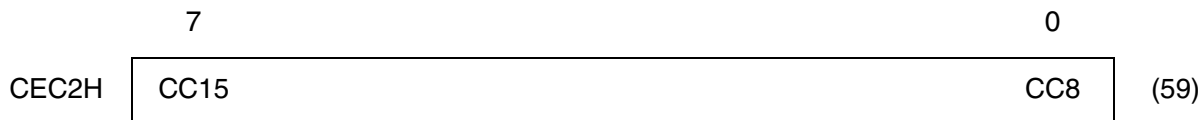
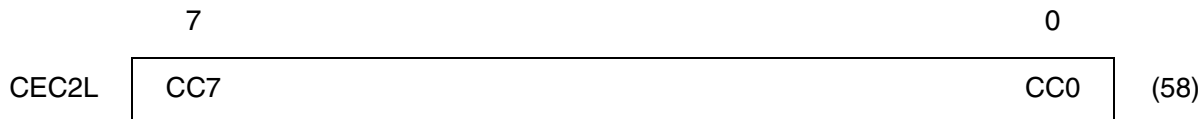

CC(15:0) CRC Error Counter (reported from TE through S_a6 -Bit)

Depending on bit LCR1.EPRM the error counter increment is selected:

LCR1.EPRM = 0:

If doubleframe format is selected, CEC2H/L has no function. If CRC-multiframe mode is enabled, CEC2H/L works as S_a6-bit error indication counter (16 bits) which counts the S_a6-bit sequence 0001 and 0011 in every received CRC submultiframe.

Incrementing the counter is only possible in the multiframe synchronous state FRS0.LMFA = 0.

S_a6-bit sequence: SA61, SA62, SA63, SA64 = 0001 or 0011 where SA61 is received in frame 1 or 9 in every multiframe.

During alarm simulation, the counter is incremented once per submultiframe up to its saturation.

Pseudo-Random Binary Sequence Error Counter

LCR1.EPRM = 1:

This 16-bit counter is incremented with every received PRBS bit error in the PRBS synchronous state RSP.LLBAD = 1. The error counter does not roll over.

During alarm simulation, the counter is incremented continuously with every second received bit.

Clearing and updating the counter is done according to bit FMR1.ECM.

If this bit is reset the error counter is permanently updated in the buffer. For correct read access of the error counter bit DEC.DCEC2 has to be set. With the rising edge of this bit updating of the buffer is stopped and the error counter is reset. Bit DEC.DCEC2 is reset automatically with reading the error counter high byte.

If FMR1.ECM is set every second (interrupt ISR3.SEC) the error counter is latched and then reset automatically. The latched error counter state should be read within the next second.

CRC Error Counter 3 (Read)

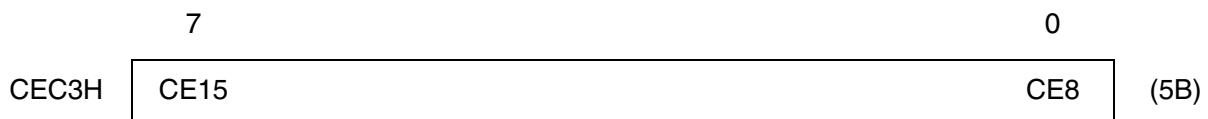
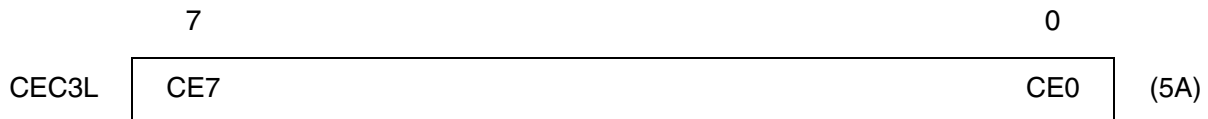

CE(15:0)

CRC Error Counter (detected at T Reference Point in S_a6 -Bit)

GCR.ECMC = 0: If doubleframe format is selected, CEC3H/L has no function. If CRC-multiframe mode is enabled, CEC3H/L works as S_a6-bit error indication counter (16 bits) which counts the S_a6-bit sequence 0010 and 0011 in every received CRC submultiframe. Incrementing the counter is only possible in the multiframe synchronous state FRS0.LMFA = 0.

S_a6-bit sequence: SA61, SA62, SA63, SA64 = 0010 or 0011 where SA61 is received in frame 1 or 9 in every multiframe. The error counter does not roll over.

During alarm simulation, the counter is incremented once per submultiframe up to its saturation.

CE(7:2)

Multiframe Counter

GCR.ECMC = 1: This 6 bit counter increments with each multiframe period in the asynchronous state FRS0.LFA/LMFA = 1.

During alarm simulation, the counter is incremented once per multiframe up to its saturation.

CE(1:0)

Change of Frame Alignment Counter

GCR.ECMC = 1: This 2 bit counter increments with each detected change of frame/multiframe alignment. The error counter does not roll over.

During alarm simulation, the counter is incremented once per multiframe up to its saturation.

Clearing and updating the counter is done according to bit FMR1.ECM.

E1 Registers

If this bit is reset the error counter is permanently updated in the buffer. For correct read access of the error counter bit DEC.DCEC3 has to be set. With the rising edge of this bit updating of the buffer is stopped and the error counter is reset. Bit DEC.DCEC3 is reset automatically with reading the error counter high byte.

If FMR1.ECM is set every second (interrupt ISR3.SEC) the error counter is latched and then automatically reset. The latched error counter state should be read within the next second.

Receive S_a4-Bit Register (Read)

	7	0	
RSA4	RS47	RS40	(5C)
RSA5	RS57	RS50	(5D)
RSA6	RS67	RS60	(5E)
RSA7	RS77	RS70	(5F)
RSA8	RS87	RS80	(60)

RS4(7:0) Receive S_a4-Bit Data (Y-Bits)

RS5(7:0) Receive S_a5-Bit Data

RS6(7:0) Receive S_a6-Bit Data

RS7(7:0) Receive S_a7-Bit Data

RS8(7:0) Receive S_a8-Bit Data

This register contains the information of the eight S_ax bits (x = 4 to 8) of the previously received CRC multiframe. These registers are updated with every multiframe begin interrupt ISR0.RMB.

RS40 is received in bit-slot 4 of every service word in frame 1, RS47 in frame 15

RS50 is received in bit-slot 5, time slot 0, frame 1, RS57 in frame 15

RS60 is received in bit-slot 6, time slot 0, frame 1, RS67 in frame 15

RS70 is received in bit-slot 7, time slot 0, frame 1, RS77 in frame 15

RS80 is received in bit-slot 8, time slot 0, frame 1, RS87 in frame 15

Valid if CRC multiframe format is enabled by setting bits FMR2.RFS1 = 1 or FMR2.RFS(1:0) = 01 (doubleframe format).

S_A Receive S_a6-Bit Status: "1010"

Receive S_a6-bit status "1010" is detected for three times in a row in the S_a6-bit positions.

S_8 Receive S_a6-Bit Status: "1000"

Receive S_a6-bit status "1000" is detected for three times in a row in the S_a6-bit positions.

Receive Signaling Pointer 1 (Read)

Value after reset: 00_H

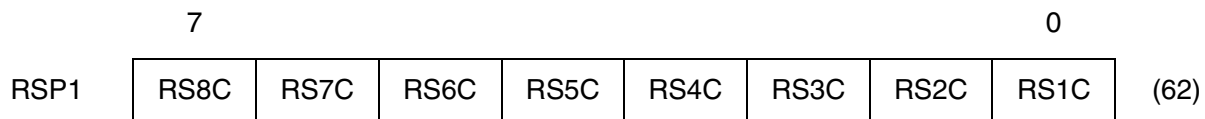

RS(8:1)C Receive Signaling Register RS(8:1) Changed

A one in each bit position indicates that the received signaling data in the corresponding RS(8:1) registers are updated. Bit RS1C is the pointer for register RS1, while RS8C points to RS8.

Receive Signaling Pointer 2 (Read)

Value after reset: 00_H

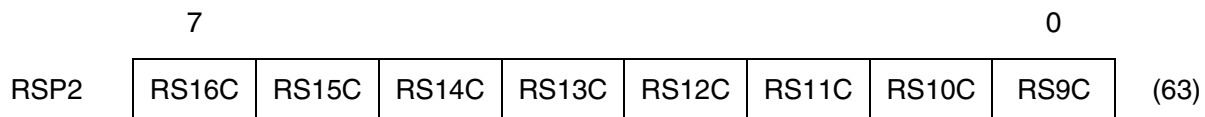

RS(16:9)C Receive Signaling Register RS9-16 Changed

A one in each bit position indicates that the received signaling data in the corresponding RS9-16 registers are updated. Bit RS9C is the pointer for register RS9, while RS16C points to RS16.

Signaling Status Register (Read)



- XDOV** **Transmit Data Overflow - HDLC Channel 1**
 More than 32 bytes have been written to the XFIFO.
 This bit is reset
- by a transmitter reset command XRES
 - when all bytes in the accessible half of the XFIFO have been moved in the inaccessible half.
- XFW** **Transmit FIFO Write Enable - HDLC Channel 1**
 Data can be written to the XFIFO.
- XREP** **Transmission Repeat - HDLC Channel 1**
 Status indication of CMDR.XREP.
- RLI** **Receive Line Inactive - HDLC Channel 1**
 Neither flags as interframe time fill nor frames are received through the signaling time slot.
- CEC** **Command Executing - HDLC Channel 1**
- 0 = No command is currently executed, the CMDR register can be written to.
- 1 = A command (written previously to CMDR) is currently executed, no further command can be temporarily written in CMDR register.
- Note: CEC is active for about 2.5 periods of the current system data rate.
- SFS** **Status Freeze Signaling**
- 0 = Freeze signaling status inactive.
- 1 = Freeze signaling status active

Receive Signaling Status Register (Read)

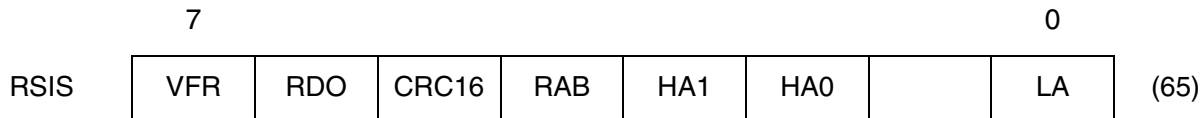

RSIS relates to the last received HDLC frame; it is copied into RFIFO when end-of-frame is recognized (last byte of each stored frame).

- VFR Valid Frame - HDLC Channel 1**
Determines whether a valid frame has been received.
1 = Valid
0 = Invalid
An invalid frame is either
- a frame which is not an integer number of 8 bits (n×8 bits) in length (e.g. 25 bits), or
 - a frame which is too short taking into account the operation mode selected by MODE (MDS(2:0)) and the selection of receive CRC on/off (CCR2.RCRC) as follows:
 - MDS(2:0) = 011 (16 bit Address),
RCRC = 0: 4 bytes; RCRC = 1: 3 or 4 bytes
 - MDS(2:0) = 010 (8 bit Address),
RCRC = 0: 3 bytes; RCRC = 1: 2 or 3 bytes
- Note: Shorter frames are not reported.
- RDO Receive Data Overflow - HDLC Channel 1**
A RFIFO data overflow has occurred during reception of the frame. Additionally, an interrupt can be generated (refer to ISR1.RDO/IMR1.RDO).
- CRC16 CRC16 Compare/Check - HDLC Channel 1**
0 = CRC check failed; received frame contains errors.
1 = CRC check o.k.; received frame is error-free.
- RAB Receive Message Aborted - HDLC Channel 1**
This bit is set in SS7 mode, if the maximum number of octets (272+7) is exceeded. The received frame was aborted from the transmitting station. According to the HDLC protocol, this frame must be discarded by the receiver station.

HA1, HA0

High Byte Address Compare - HDLC Channel 1

Significant only if 2-byte address mode or SS7 mode has been selected.

In operating modes which provide high byte address recognition, the FALC56 compares the high byte of a 2-byte address with the contents of two individually programmable registers (RAH1, RAH2) and the fixed values FE_H and FC_H (broadcast address).

Depending on the result of this comparison, the following bit combinations are possible (SS7 support not active):

00 = RAH2 has been recognized

01 = Broadcast address has been recognized

10 = RAH1 has been recognized C/R = 0 (bit 1)

11 = RAH1 has been recognized C/R = 1 (bit 1)

Note: If RAH1, RAH2 contain identical values, a match is indicated by "10" or "11".

If Signaling System 7 support is activated (see MODE register), the bit functions are defined as follows:

00 = Not valid

01 = Fill in signaling unit (FISU) detected

10 = Link status signaling unit (LSSU) detected

11 = Message signaling unit (MSU) detected

LA

Low Byte Address Compare - HDLC Channel 1

Significant in HDLC modes only.

The low byte address of a 2-byte address field, or the single address byte of a 1-byte address field is compared to two registers. (RAL1, RAL2).

0 = RAL2 has been recognized

1 = RAL1 has been recognized

Receive Byte Count Low - HDLC Channel 1 (Read)

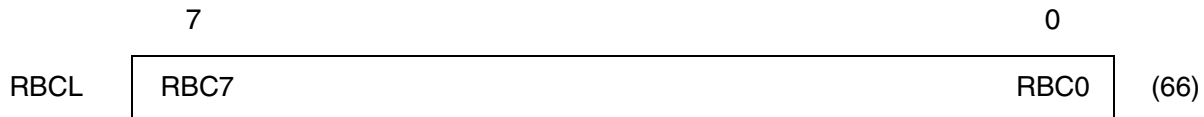

Together with RBCH, bits RBC(11:8), indicates the length of a received frame (1 to 4095 bytes). Bits RBC(4:0) indicate the number of valid bytes currently in RFIFO. These registers must be read by the CPU following a RME interrupt.

Received Byte Count High - HDLC Channel 1 (Read)

Value after reset: 000_{xxxxx}

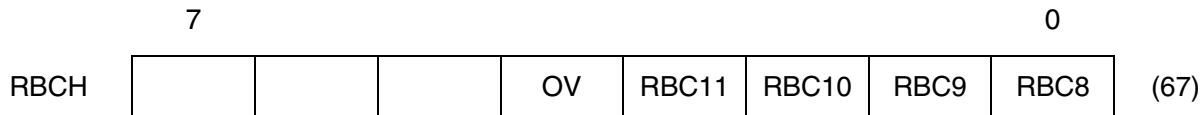

OV Counter Overflow - HDLC Channel 1

More than 4095 bytes received.

RBC(11:8) Receive Byte Count - HDLC Channel 1 (most significant bits)

Together with RBCL, bits RBC(7:0) indicates the length of the received frame.

Interrupt Status Register 0 (Read)

Value after reset: 00_H

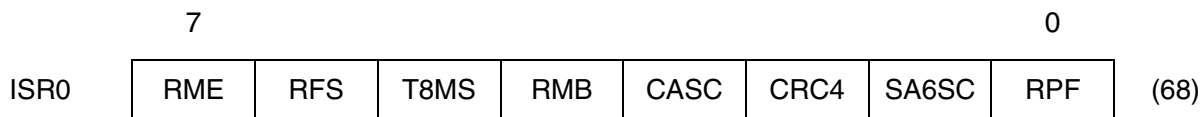

All bits are reset when ISR0 is read.

If bit GCR.VIS is set, interrupt statuses in ISR0 are flagged although they are masked by register IMR0. However, these masked interrupt statuses neither generate a signal on INT, nor are visible in register GIS.

RME Receive Message End - HDLC Channel 1

One complete message of length less than 32 bytes, or the last part of a frame at least 32 bytes long is stored in the receive FIFO, including the status byte.

The complete message length can be determined reading the RBCH, RBCL registers, the number of bytes currently stored in RFIFO is given by RBC(4:0). Additional information is available in the RSIS register.

RFS Receive Frame Start - HDLC Channel 1

This is an early receiver interrupt activated after the start of a valid frame has been detected, i.e. after an address match (in operation modes providing address recognition), or after the opening flag (transparent mode 0) is detected, delayed by two bytes. After an RFS interrupt, the contents of

- RAL1
- RSIS bits 3 to 1

are valid and can be read by the CPU.

T8MS Receive Time Out 8 ms

Only active if multiframing is enabled.

The framer has found the double framing (basic framing) FRS0.LFA = 0 and is searching for the multiframing. This interrupt is set to indicate that no multiframing was found within a time window of 8 ms. In multiframe synchronous state this interrupt is not generated. Refer also to floating multiframe alignment window.

RMB Receive Multiframe Begin

This bit is set with the beginning of a received CRC multiframe related to the internal receive line timing.

In CRC multiframe format FMR2.RFS1 = 1 or in doubleframe format FMR2.RFS(1:0) = 01 this interrupt occurs every 2 ms. If FMR2.RFS(1:0) = 00 this interrupt is generated every doubleframe (512 bits).

CASC Received CAS Information Changed

This bit is set with the updating of a received CAS multiframe information in the registers RS(16:1). If the last received CAS information is different to the previous received one, this interrupt is generated after update has been completed. This interrupt only occurs only in TS0 and TS16 synchronous state. The registers RS(16:1) should be read within the next 2 ms otherwise the contents is lost.

- CRC4** **Receive CRC4 Error**
 0 = No CRC4 error occurs.
 1 = The CRC4 check of the last received submultiframe failed.
- SA6SC** **Receive S_a6-Bit Status Changed**
 With every change of state of the received S_a6-bit combinations this interrupt is set.
- RPF** **Receive Pool Full**
 32 bytes of a frame have arrived in the receive FIFO. The frame is not yet completely received.

Interrupt Status Register 1 (Read)

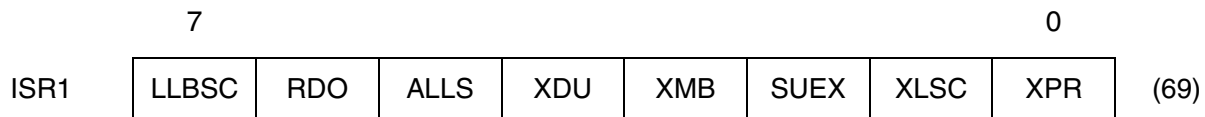

All bits are reset when ISR1 is read.
 If bit GCR.VIS is set, interrupt statuses in ISR1 are flagged although they are masked by register IMR1. However, these masked interrupt statuses neither generate a signal on INT, nor are visible in register GIS.

- LLBSC** **Line Loop-Back Status Change**
 Depending on bit LCR1.EPRM the source of this interrupt status changed:
 LCR1.EPRM = 0: This bit is set, if the LLB activate signal or the LLB deactivate signal, respectively, is detected over a period of 25 ms with a bit error rate less than 10⁻².
 The LLBSC bit is also set, if the current detection status is left, i.e., if the bit error rate exceeds 10⁻².
 The actual detection status can be read from the RSP.LLBAD and RSP.LLBDD, respectively.
- PRBS Status Change**
 LCR1.EPRM = 1: With any change of state of the PRBS synchronizer this bit is set. The current status of the PRBS synchronizer is indicated in RSP.LLBAD.

- RDO** **Receive Data Overflow - HDLC Channel 1**
- This interrupt status indicates that the CPU did not respond fast enough to an RPF or RME interrupt and that data in RFIFO has been lost. Even when this interrupt status is generated, the frame continues to be received when space in the RFIFO is available again.
- Note: Whereas the bit RSIS.RDO in the frame status byte indicates whether an overflow occurred when receiving the frame currently accessed in the RFIFO, the ISR1.RDO interrupt status is generated as soon as an overflow occurs and does not necessarily pertain to the frame currently accessed by the processor.
- ALLS** **All Sent - HDLC Channel 1**
- This bit is set if the last bit of the current frame has been sent completely and XFIFO is empty. This bit is valid in HDLC mode only.
- XDU** **Transmit Data Underrun - HDLC Channel 1**
- Transmitted frame was terminated with an abort sequence because no data was available for transmission in XFIFO and no XME was issued.
- Note: Transmitter and XFIFO are reset and deactivated if this condition occurs. They are reactivated not before this interrupt status register has been read. Thus, XDU should not be masked by register IMR1.
- XMB** **Transmit Multiframe Begin**
- This bit is set every 2 ms with the beginning of a transmitted multiframe related to the internal transmit line interface timing. Just before setting this bit registers XS(16:1) are copied in the transmit shift registers. The registers XS(16:1) are empty and has to be updated otherwise the contents is retransmitted.
- SUEX** **Signaling Unit Error Threshold Exceeded - HDLC Channel 1**
- Masks the indication by interrupt that the selected error threshold for SS7 signaling units has been exceeded.
- 0 = Signaling unit error count below selected threshold
1 = Signaling unit error count exceeded selected threshold
- Note: SUEX is only valid, if SS7 mode is selected.
If SUEX is caused by an aborted/invalid frame, the interrupt will be issued regularly until a valid frame is received (e.g. a FISU).

XLSC Transmit Line Status Change

XLSC is set with the rising edge of the bit FRS1.XLO or with any change of bit FRS1.XLS.

The actual status of the transmit line monitor can be read from the FRS1.XLS and FRS1.XLO.

XPR Transmit Pool Ready - HDLC Channel 1

A data block of up to 32 bytes can be written to the transmit FIFO. XPR enables the fastest access to XFIFO. It has to be used for transmission of long frames, back-to-back frames or frames with shared flags.

Interrupt Status Register 2 (Read)

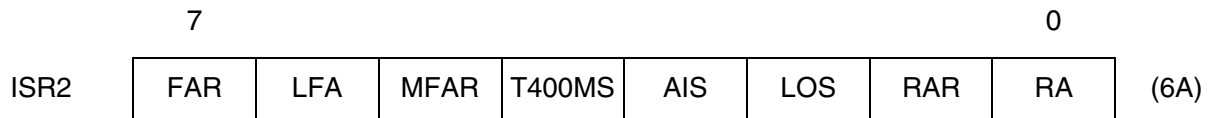

All bits are reset when ISR2 is read.

If bit GCR.VIS is set, interrupt statuses in ISR2 are flagged although they are masked by register IMR2. However, these masked interrupt statuses neither generate a signal on INT, nor are visible in register GIS.

FAR Frame Alignment Recovery

The framer has reached doubleframe synchronization. Set when bit FRS0.LFA is reset. It is set also after alarm simulation is finished and the receiver is still synchronous.

LFA Loss of Frame Alignment

The framer has lost synchronization and bit FRS0.LFA is set. It is set during alarm simulation.

MFAR Multiframe Alignment Recovery

Set when the framer has found two CRC-multiframes at an interval of $n \times 2$ ms ($n = 1, 2, 3,$ and so forth) without a framing error. At the same time bit FRS0.LMFA is reset.

It is set also after alarm simulation is finished and the receiver is still synchronous. Only active if CRC-multiframe format is selected.

T400MS	Receive Time Out 400 ms Only active if multiframing is enabled. The framer has found the doubleframes (basic framing) FRS0.LFA = 0 and is searching for the multiframing. This interrupt is set to indicate that no multiframing was found within a time window of 400 ms after basic framing has been achieved. In multiframe synchronous state this interrupt is not generated.
AIS	Alarm Indication Signal This bit is set when an alarm indication signal is detected and bit FRS0.AIS is set. It is set during alarm simulation. If GCR.SCI is set high this interrupt status bit is set with every change of state of FRS0.AIS.
LOS	Loss-of-Signal This bit is set when a loss-of-signal alarm is detected in the received bit stream and FRS0.LOS is set. It is set during alarm simulation. If GCR.SCI is set high this interrupt status bit is set with every change of state of FRS0.LOS.
RAR	Remote Alarm Recovery Set if a remote alarm in TS0 is cleared and bit FRS0.RRA is reset. It is set also after alarm simulation is finished and no remote alarm is detected.
RA	Remote Alarm Set if a remote alarm in TS0 is detected and bit FRS0.RRA is set. It is set during alarm simulation.

Interrupt Status Register 3 (Read)

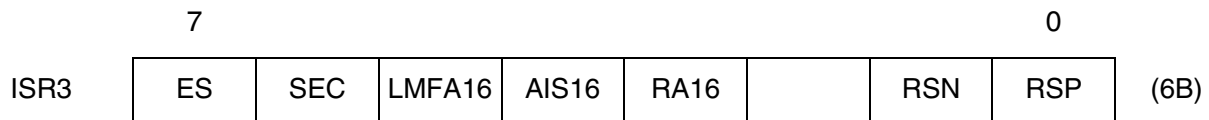

All bits are reset when ISR3 is read.

If bit GCR.VIS is set, interrupt statuses in ISR3 are flagged although they are masked by register IMR3. However, these masked interrupt statuses neither generate a signal on INT, nor are visible in register GIS.

ES Errored Second

This bit is set if at least one enabled interrupt source by ESM is set during the time interval of one second. Interrupt sources of ESM register:

- LFA = Loss of frame alignment detected (FRS0.LFA)
- FER = Framing error received
- CER = CRC error received
- AIS = Alarm indication signal (FRS0.AIS)
- LOS = Loss-of-signal (FRS0.LOS)
- CVE = Code violation detected
- SLIP = Receive Slip positive/negative detected
- EBE = E-Bit error detected (RSP.RS13/15)

SEC Second Timer

The internal one-second timer has expired. The timer is derived from clock RCLK or external pin SEC/FSC.

LMFA16 Loss of Multiframe Alignment TS 16

Multiframe alignment of time slot 16 has been lost if two consecutive multiframe pattern are not detected or if in 16 consecutive time slot 16 all bits are reset.

If register GCR.SCI is high this interrupt status bit is set with every change of state of FRS1.TS16LFA.

AIS16 Alarm Indication Signal TS 16 Status Change

The alarm indication signal AIS in time slot 16 for the 64 kbit/s channel associated signaling is detected or cleared. A change in bit FRS1.TS16AIS sets this interrupt. (This bit is set if the incoming TS 16 signal contains less than 4 zeros in each of two consecutive TS16-multiframe periods.)

- RA16 Remote Alarm Time Slot 16 Status Change**
A change in the remote alarm bit in CAS multiframe alignment word is detected.
- RSN Receive Slip Negative**
The frequency of the receive route clock is greater than the frequency of the receive system interface working clock based on 2.048 MHz. A frame is skipped. It is set during alarm simulation.
- RSP Receive Slip Positive**
The frequency of the receive route clock is less than the frequency of the receive system interface working clock based on 2.048 MHz. A frame is repeated. It is set during alarm simulation.

Interrupt Status Register 4 (Read)

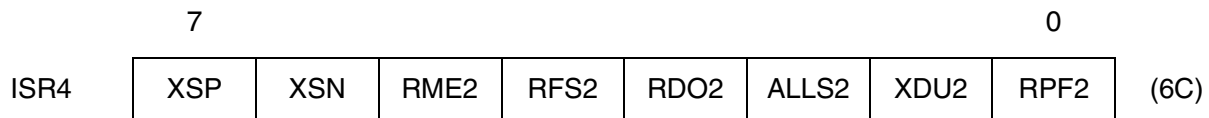

All bits are reset when ISR4 is read.

If bit GCR.VIS is set, interrupt statuses in ISR4 are flagged although they are masked by register IMR4. However, these masked interrupt statuses neither generate a signal on INT, nor are visible in register GIS.

- XSP Transmit Slip Positive**
The frequency of the transmit clock is less than the frequency of the transmit system interface working clock based on 2.048 MHz. A frame is repeated. After a slip has performed writing of register XC1 is not necessary.
- XSN Transmit Slip Negative**
The frequency of the transmit clock is greater than the frequency of the transmit system interface working clock based on 2.048 MHz. A frame is skipped. After a slip has performed writing of register XC1 is not necessary.

- RME2** **Receive Message End - HDLC Channel 2**
- One complete message of length less than 32 bytes, or the last part of a frame at least 32 bytes long is stored in the receive FIFO2, including the status byte.
- The complete message length can be determined reading register RBC2, the number of bytes currently stored in RFIFO2 is given by RBC2(6:0). Additional information is available in register RSIS2.
- RFS2** **Receive Frame Start - HDLC Channel 2**
- This is an early receiver interrupt activated after the start of a valid frame has been detected, i.e. after an address match (in operation modes providing address recognition), or after the opening flag (transparent mode 0) is detected, delayed by two bytes. After an RFS2 interrupt, the contents of
- RAL1
 - RSIS2 bits 3 to 1
- are valid and can be read by the CPU.
- RDO2** **Receive Data Overflow - HDLC Channel 2**
- This interrupt status indicates that the CPU did not respond fast enough to an RPF2 or RME2 interrupt and that data in RFIFO2 has been lost. Even when this interrupt status is generated, the frame continues to be received when space in the RFIFO2 is available again.
- Note: Whereas the bit RSIS2.RDO2 in the frame status byte indicates whether an overflow occurred when receiving the frame currently accessed in the RFIFO2, the ISR4.RDO2 interrupt status is generated as soon as an overflow occurs and does not necessarily pertain to the frame currently accessed by the processor.
- ALLS2** **All Sent - HDLC Channel 2**
- This bit is set if the last bit of the current frame has been sent completely and XFIFO2 is empty. This bit is valid in HDLC mode only.

XDU2 Transmit Data Underrun - HDLC Channel 2

Transmitted frame was terminated with an abort sequence because no data was available for transmission in XFIFO2 and no XME2 was issued.

Note: Transmitter and XFIFO2 are reset and deactivated if this condition occurs. They are reactivated not before this interrupt status register has been read. Thus, XDU2 should not be masked via register IMR4.

RPF2 Receive Pool Full - HDLC Channel 2

32 bytes of a frame have arrived in the receive FIFO2. The frame is not yet completely received.

Interrupt Status Register 5 (Read)

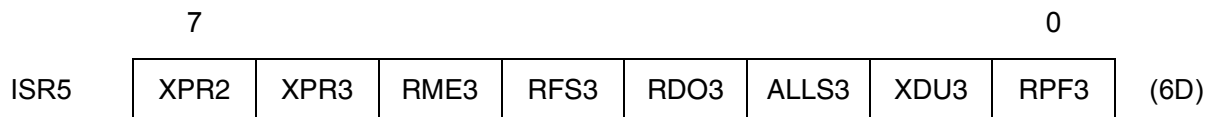

All bits are reset when ISR5 is read.

If bit GCR.VIS is set, interrupt statuses in ISR5 are flagged although they are masked via register IMR5. However, these masked interrupt statuses neither generate a signal on INT, nor are visible in register GIS.

XPR2 Transmit Pool Ready - HDLC Channel 2

A data block of up to 32 bytes can be written to the transmit FIFO2. XPR2 enables the fastest access to XFIFO2. It has to be used for transmission of long frames, back-to-back frames or frames with shared flags.

XPR3 Transmit Pool Ready - HDLC Channel 3

A data block of up to 32 bytes can be written to the transmit FIFO3. XPR3 enables the fastest access to XFIFO3. It has to be used for transmission of long frames, back-to-back frames or frames with shared flags.

- RME3** **Receive Message End - HDLC Channel 3**
- One complete message of length less than 32 bytes, or the last part of a frame at least 32 bytes long is stored in the receive FIFO3, including the status byte.
- The complete message length can be determined reading register RBC3, the number of bytes currently stored in RFIFO3 is given by RBC3(6:0). Additional information is available in register RSIS3.
- RFS3** **Receive Frame Start - HDLC Channel 3**
- This is an early receiver interrupt activated after the start of a valid frame has been detected, i.e. after an address match (in operation modes providing address recognition), or after the opening flag (transparent mode 0) is detected, delayed by two bytes. After an RFS2 interrupt, the contents of
- RAL1
 - RSIS3 bits 3 to 1
- are valid and can be read by the CPU.
- RDO3** **Receive Data Overflow - HDLC Channel 3**
- This interrupt status indicates that the CPU did not respond fast enough to an RPF3 or RME3 interrupt and that data in RFIFO3 has been lost. Even when this interrupt status is generated, the frame continues to be received when space in the RFIFO3 is available again.
- Note: Whereas the bit RSIS3.RDO3 in the frame status byte indicates whether an overflow occurred when receiving the frame currently accessed in the RFIFO3, the ISR5.RDO3 interrupt status is generated as soon as an overflow occurs and does not necessarily pertain to the frame currently accessed by the processor.
- ALLS3** **All Sent - HDLC Channel 3**
- This bit is set if the last bit of the current frame has been sent completely and XFIFO3 is empty. This bit is valid in HDLC mode only.

XDU3 Transmit Data Underrun - HDLC Channel 3

Transmitted frame was terminated with an abort sequence because no data was available for transmission in XFIFO3 and no XME3 was issued.

Note: Transmitter and XFIFO3 are reset and deactivated if this condition occurs. They are reactivated not before this interrupt status register has been read. Thus, XDU3 should not be masked via register IMR5.

RPF3 Receive Pool Full - HDLC Channel 3

32 bytes of a frame have arrived in the receive FIFO3. The frame is not yet completely received.

Global Interrupt Status Register (Read)

Value after reset: 00_H

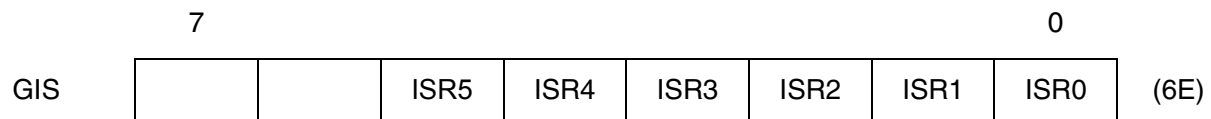

This status register points to pending interrupts sourced by ISR(5:0).

Receive CAS Register (Read)

Value after reset: not defined

Table 62 Receive CAS Registers (E1)

	7				0				
RS1	0	0	0	0	X	Y	X	X	(70)
RS2	A1	B1	C1	D1	A16	B16	C16	D16	(71)
RS3	A2	B2	C2	D2	A17	B17	C17	D17	(72)
RS4	A3	B3	C3	D3	A18	B18	C18	D18	(73)
RS5	A4	B4	C4	D4	A19	B19	C19	D19	(74)
RS6	A5	B5	C5	D5	A20	B20	C20	D20	(75)
RS7	A6	B6	C6	D6	A21	B21	C21	D21	(76)
RS8	A7	B7	C7	D7	A22	B22	C22	D22	(77)
RS9	A8	B8	C8	D8	A23	B23	C23	D23	(78)
RS10	A9	B9	C9	D9	A24	B24	C24	D24	(79)
RS11	A10	B10	C10	D10	A25	B25	C25	D25	(7A)
RS12	A11	B11	C11	D11	A26	B26	C26	D26	(7B)
RS13	A12	B12	C12	D12	A27	B27	C27	D27	(7C)
RS14	A13	B13	C13	D13	A28	B28	C28	D28	(7D)
RS15	A14	B14	C14	D14	A29	B29	C29	D29	(7E)
RS16	A15	B15	C15	D15	A30	B30	C30	D30	(7F)

Receive CAS Register (16:1)

Each register except RS1 contains the received CAS bits for two time slots. The received CAS multiframe is compared to the previously received one. If the contents changed a CAS multiframe changed interrupt (ISR0.CASC) is generated and informs the user that a new multiframe has to be read within the next 2 ms. If requests for reading the RS(16:1) register are ignored, the received data is lost. RS1 contains frame 0 of the CAS multiframe. MSB is received first.

Additionally a receive signaling data change pointer indicates an update of register RS(16:1). Refer also to register RSP(2:1).

Access to RS(16:1) registers is only valid if the serial receive signaling access on the system highway is disabled.

Receive Byte Count Register 2 (Read)

Value after reset: 00_H

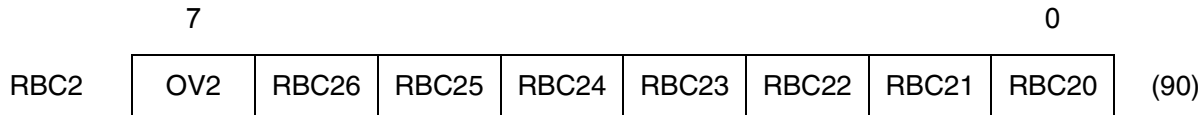

OV2 Counter Overflow - HDLC Channel 2

- 0 = Less than or equal to 128 bytes received
- 1 = More than 128 bytes received

RBC2(6:0) Receive Byte Count - HDLC Channel 2

Indicates the length of a received frame.

Receive Byte Count Register 3 (Read)

Value after reset: 00_H

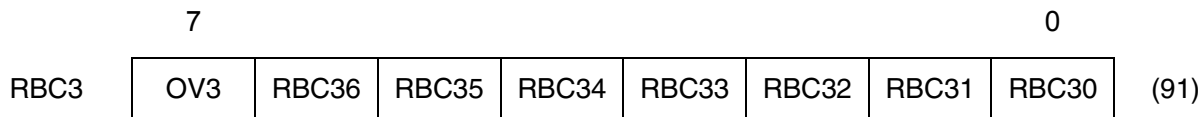

OV3 Counter Overflow - HDLC Channel 3

- 0 = Less than or equal to 128 bytes received
- 1 = More than 128 bytes received

RBC3(6:0) Receive Byte Count - HDLC Channel 3

Indicates the length of a received frame.

Signaling Status Register 2 (Read)

Value after reset: 00_H

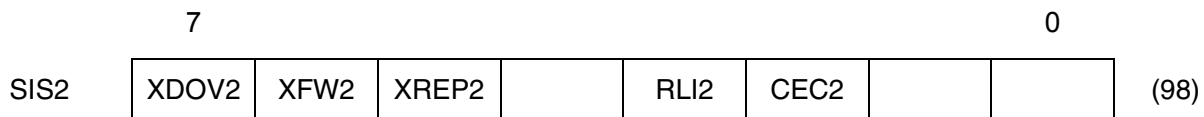

XDOV2 Transmit Data Overflow - HDLC Channel 2

More than 32 bytes have been written to the XFIFO2.
This bit is reset

- by a transmitter reset command XRES or
- when all bytes in the accessible half of the XFIFO2 have been moved in the inaccessible half.

XFW2	Transmit FIFO Write Enable - HDLC Channel 2 Data can be written to the XFIFO2.
XREP2	Transmission Repeat - HDLC Channel 2 Status indication of CMDR2.XREP2.
RLI2	Receive Line Inactive - HDLC Channel 2 Neither flags as interframe time fill nor frames are received via the signaling time slot.
CEC2	Command Executing - HDLC Channel 2 0 = No command is currently executed, the CMDR3 register can be written to. 1 = A command (written previously to CMDR3) is currently executed, no further command can be temporarily written in CMDR3 register. Note: CEC2 will be active at most 2.5 periods of the current system data rate.

Receive Signaling Status Register 2 (Read)

Value after reset: 00_H

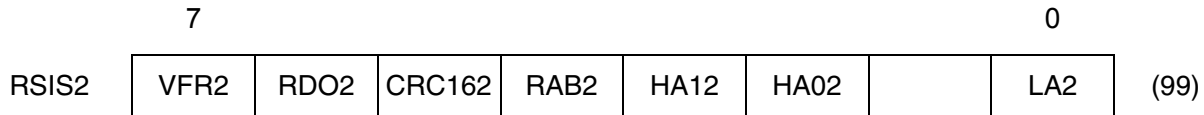

RSIS2 relates to the last received HDLC channel 2 frame; it is copied into RFIFO2 when end-of-frame is recognized (last byte of each stored frame).

VFR2 Valid Frame - HDLC Channel 2

Determines whether a valid frame has been received.

- 1 = Valid
- 0 = Invalid

An invalid frame is either

- a frame which is not an integer number of 8 bits (n×8 bits) in length (e.g. 25 bits), or
- a frame which is too short taking into account the operation mode selected via MODE2 (MDS2(2:0)) and the selection of receive CRC ON/OFF (CCR3.RCRC2) as follows:
 - MDS2(2:0)=011 (16 bit Address),
RCRC2=0: 4 bytes; RCRC2=1: 3 or 4 bytes
 - MDS2(2:0)=010 (8 bit Address),
RCRC2=0: 3 bytes; RCRC2=1: 2 or 3 bytes

Note: Shorter frames are not reported.

RDO2 Receive Data Overflow - HDLC Channel 2

A data overflow has occurred during reception of the frame.

Additionally, an interrupt can be generated (refer to ISR4.RDO2/IMR4.RDO2).

CRC162 CRC16 Compare/Check - HDLC Channel 2

- 0 = CRC check failed; received frame contains errors.
- 1 = CRC check o.k.; received frame is error-free.

RAB2 Receive Message Aborted - HDLC Channel 2

This bit is set, if more than 5 contiguous 1-bits are detected.

HA12, HA02 High Byte Address Compare - HDLC Channel 2

Significant only if 2-byte address mode is selected.

In operating modes which provide high byte address recognition, the FALC[®] compares the high byte of a 2-byte address with the contents of two individually programmable registers (RAH1, RAH2) and the fixed values FE_H and FC_H (broadcast address).

Depending on the result of this comparison, the following bit combinations are possible:

- 00 = RAH2 has been recognized
- 01 = Broadcast address has been recognized
- 10 = RAH1 has been recognized C/R=0 (bit 1)
- 11 = RAH1 has been recognized C/R=1 (bit 1)

Note: If RAH1, RAH2 contain identical values, a match is indicated by "10" or "11".

LA2 Low Byte Address Compare - HDLC Channel 2

Significant in HDLC modes only.

The low byte address of a 2-byte address field, or the single address byte of a 1-byte address field is compared with two registers. (RAL1, RAL2).

- 0 = RAL2 has been recognized
- 1 = RAL1 has been recognized

Signaling Status Register 3 (Read)

Value after reset: 00_H

	7						0	
SIS3	XDOV3	XFW3	XREP3		RLI3	CEC3		(9A)

XDOV3 Transmit Data Overflow - HDLC Channel 3

More than 32 bytes have been written to the XFIFO3.

This bit is reset

- by a transmitter reset command XRES or
- when all bytes in the accessible half of the XFIFO3 have been moved in the inaccessible half.

XFW3 Transmit FIFO Write Enable - HDLC Channel 3

Data can be written to the XFIFO3.

- XREP3** **Transmission Repeat - HDLC Channel 3**
Status indication of CMDR3.XREP3.
- RLI3** **Receive Line Inactive - HDLC Channel 3**
Neither flags as interframe time fill nor frames are received via the signaling time slot.
- CEC3** **Command Executing - HDLC Channel 3**
0 = No command is currently executed, the CMDR4 register can be written to.
1 = A command (written previously to CMDR4) is currently executed, no further command can be temporarily written in CMDR4 register.
Note: CEC3 will be active up to 2.5 periods of the current system data rate.

Receive Signaling Status Register 3 (Read)

Value after reset: 00_H

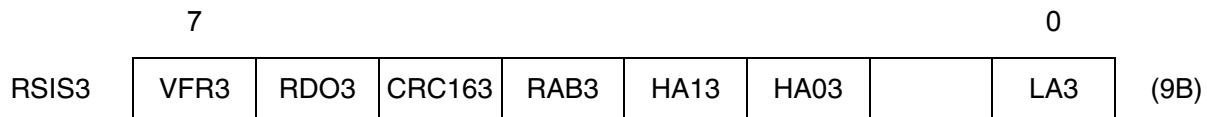

RSIS3 relates to the last received HDLC channel 3 frame; it is copied into RFIFO3 when end-of-frame is recognized (last byte of each stored frame).

- VFR3** **Valid Frame - HDLC Channel 3**
Determines whether a valid frame has been received.
1 = Valid
0 = Invalid
An invalid frame is either
– a frame which is not an integer number of 8 bits (n×8 bits) in length (e.g. 25 bits), or
– a frame which is too short taking into account the operation mode selected via MODE3 (MDS3(2:0)) and the selection of receive CRC ON/OFF (CCR4.RCRC3) as follows:
- MDS3(2:0)=011 (16 bit Address),
RCRC3=0: 4 bytes; RCRC3=1: 3 or 4 bytes
 - MDS3(2:0)=010 (8 bit Address),
RCRC3=0: 3 bytes; RCRC3=1: 2 or 3 bytes

Note: Shorter frames are not reported.

RDO3**Receive Data Overflow - HDLC Channel 3**

A data overflow has occurred during reception of the frame.

Additionally, an interrupt can be generated (refer to ISR5.RDO3/IMR5.RDO3).

CRC163**CRC16 Compare/Check - HDLC Channel 3**

0 = CRC check failed; received frame contains errors.

1 = CRC check o.k.; received frame is error-free.

RAB3**Receive Message Aborted - HDLC Channel 3**

This bit is set, if more than 5 contiguous 1-bits are detected.

HA13, HA03**High Byte Address Compare - HDLC Channel 3**

Significant only if 2-byte address mode is selected.

In operating modes which provide high byte address recognition, the FALC[®] compares the high byte of a 2-byte address with the contents of two individually programmable registers (RAH1, RAH2) and the fixed values FE_H and FC_H (broadcast address).

Depending on the result of this comparison, the following bit combinations are possible:

00 = RAH2 has been recognized

01 = Broadcast address has been recognized

10 = RAH1 has been recognized C/R=0 (bit 1)

11 = RAH1 has been recognized C/R=1 (bit 1)

Note: If RAH1, RAH2 contain identical values, a match is indicated by "10" or "11".

LA3**Low Byte Address Compare - HDLC Channel 3**

Significant in HDLC modes only.

The low byte address of a 2-byte address field, or the single address byte of a 1-byte address field is compared with two registers. (RAL1, RAL2).

0 = RAL2 has been recognized

1 = RAL1 has been recognized

Receive FIFO 2 (Read)

Value after reset: 00_H

	7		0	
RFIFO2	RF7		RF0	(9C)
RFIFO2	RF15		RF8	(9D)

RF(15:0) Receive FIFO - HDLC Channel 2

The function is equivalent to RFIFO of HDLC channel 1.

Receive FIFO 3 (Read)

Value after reset: 00_H

	7		0	
RFIFO3	RF7		RF0	(9E)
RFIFO3	RF15		RF8	(9F)

RF(15:0) Receive FIFO - HDLC Channel 3

The function is equivalent to RFIFO of HDLC channel 1.

Identification Register (Read)

Value after reset: xxxxxx11

	7		0						
WID	x	x	x	x	x	x	1	1	(EC)

Additional version identification register.

10 T1/J1 Registers

10.1 T1/J1 Control Register Addresses

Table 63 T1/J1 Control Register Address Arrangement

Address	Register	Type	Comment	Page
00	XFIFO	W	Transmit FIFO	334
01	XFIFO	W	Transmit FIFO	334
02	CMDR	W	Command Register	334
03	MODE	R/W	Mode Register	336
04	RAH1	R/W	Receive Address High 1	337
05	RAH2	R/W	Receive Address High 2	337
06	RAL1	R/W	Receive Address Low 1	337
07	RAL2	R/W	Receive Address Low 2	337
08	IPC	R/W	Interrupt Port Configuration	338
09	CCR1	R/W	Common Configuration Register 1	338
0A	CCR2	R/W	Common Configuration Register 2	341
0C	RTR1	R/W	Receive Time Slot Register 1	342
0D	RTR2	R/W	Receive Time Slot Register 2	342
0E	RTR3	R/W	Receive Time Slot Register 3	342
0F	RTR4	R/W	Receive Time Slot Register 4	342
10	TTR1	R/W	Transmit Time Slot Register 1	343
11	TTR2	R/W	Transmit Time Slot Register 2	343
12	TTR3	R/W	Transmit Time Slot Register 3	343
13	TTR4	R/W	Transmit Time Slot Register 4	343
14	IMR0	R/W	Interrupt Mask Register 0	344
15	IMR1	R/W	Interrupt Mask Register 1	344
16	IMR2	R/W	Interrupt Mask Register 2	344
17	IMR3	R/W	Interrupt Mask Register 3	344
18	IMR4	R/W	Interrupt Mask Register 4	344
19	IMR5	R/W	Interrupt Mask Register 5	344
1B	IERR	R/W	Single Bit Error Insertion Register	345
1C	FMR0	R/W	Framer Mode Register 0	345

T1/J1 Registers
Table 63 T1/J1 Control Register Address Arrangement (cont'd)

Address	Register	Type	Comment	Page
1D	FMR1	R/W	Framer Mode Register 1	347
1E	FMR2	R/W	Framer Mode Register 2	349
1F	LOOP	R/W	Channel Loop-Back	351
20	FMR4	R/W	Framer Mode Register 4	352
21	FMR5	R/W	Framer Mode Register 5	354
22	XC0	R/W	Transmit Control 0	355
23	XC1	R/W	Transmit Control 1	356
24	RC0	R/W	Receive Control 0	357
25	RC1	R/W	Receive Control 1	359
26	XPM0	R/W	Transmit Pulse Mask 0	361
27	XPM1	R/W	Transmit Pulse Mask 1	361
28	XPM2	R/W	Transmit Pulse Mask 2	361
2B	IDLE	R/W	Idle Channel Code	362
2C	XDL1	R/W	Transmit DL-Bit Register 1	362
2D	XDL2	R/W	Transmit DL-Bit Register 2	362
2E	XDL3	R/W	Transmit DL-Bit Register 3	362
2F	CCB1	R/W	Clear Channel Register 1	363
30	CCB2	R/W	Clear Channel Register 2	363
31	CCB3	R/W	Clear Channel Register 3	363
32	ICB1	R/W	Idle Channel Register 1	364
33	ICB2	R/W	Idle Channel Register 2	364
34	ICB3	R/W	Idle Channel Register 3	364
36	LIM0	R/W	Line Interface Mode 0	364
37	LIM1	R/W	Line Interface Mode 1	366
38	PCD	R/W	Pulse Count Detection	367
39	PCR	R/W	Pulse Count Recovery	368
3A	LIM2	R/W	Line Interface Register 2	369
3B	LCR1	R/W	Loop Code Register 1	370
3C	LCR2	R/W	Loop Code Register 2	372
3D	LCR3	R/W	Loop Code Register 3	372

Table 63 T1/J1 Control Register Address Arrangement (cont'd)

Address	Register	Type	Comment	Page
3E	SIC1	R/W	System Interface Control 1	373
3F	SIC2	R/W	System Interface Control 2	374
40	SIC3	R/W	System Interface Control 3	376
44	CMR1	R/W	Clock Mode Register 1	378
45	CMR2	R/W	Clock Mode Register 2	379
46	GCR	R/W	Global Configuration Register 1	381
47	ESM	R/W	Errored Second Mask	382
60	DEC	W	Disable Error Counter	382
70	XS1	W	Transmit Signaling Register 1	383
71	XS2	W	Transmit Signaling Register 2	383
72	XS3	W	Transmit Signaling Register 3	383
73	XS4	W	Transmit Signaling Register 4	383
74	XS5	W	Transmit Signaling Register 5	383
75	XS6	W	Transmit Signaling Register 6	383
76	XS7	W	Transmit Signaling Register 7	383
77	XS8	W	Transmit Signaling Register 8	383
78	XS9	W	Transmit Signaling Register 9	383
79	XS10	W	Transmit Signaling Register 10	383
7A	XS11	W	Transmit Signaling Register 11	383
7B	XS12	W	Transmit Signaling Register 12	383
80	PC1	R/W	Port Configuration 1	384
81	PC2	R/W	Port Configuration 2	384
82	PC3	R/W	Port Configuration 3	384
83	PC4	R/W	Port Configuration 4	384
84	PC5	R/W	Port Configuration 5	386
85	GPC1	R/W	Global Port Configuration 1	387
86	PC6	R/W	Port Configuration 6	388
x87	CMDR2	W	Command Register 2	389
88	CMDR3	W	Command Register 3	389
89	CMDR4	W	Command Register 4	390

Table 63 T1/J1 Control Register Address Arrangement (cont'd)

Address	Register	Type	Comment	Page
8B	CCR3	R/W	Common Control Register 3	391
8C	CCR4	R/W	Common Control Register 4	393
x8D	CCR5	R/W	Common Control Register 5	394
8E	MODE2	R/W	Mode Register 2	395
8F	MODE3	R/W	Mode Register 3	396
92	GCM1	R/W	Global Counter Mode 1	397
93	GCM2	R/W	Global Counter Mode 2	397
94	GCM3	R/W	Global Counter Mode 3	398
95	GCM4	R/W	Global Counter Mode 4	399
96	GCM5	R/W	Global Counter Mode 5	400
97	GCM6	R/W	Global Counter Mode 6	400
9C	XFIFO2	W	Transmit FIFO 2	402
9D	XFIFO2	W	Transmit FIFO 2	402
9E	XFIFO3	W	Transmit FIFO 3	402
9F	XFIFO3	W	Transmit FIFO 3	402
A0	TSEO	R/W	Time Slot Even/Odd Select	402
A1	TSBS1	R/W	Time Slot Bit Select 1	403
A2	TSBS2	R/W	Time Slot Bit Select 2	404
A3	TSBS3	R/W	Time Slot Bit Select 3	404
A4	TSS2	R/W	Time Slot Select 2	405
A5	TSS3	R/W	Time Slot Select 2	405
A8	TPC0	R/W	Test Pattern Control Register 0	406

After reset all control registers except the XFIFO and XS(12:1) are initialized to defined values.

Unused bits have to be cleared.

10.2 Detailed Description of T1/J1 Control Registers

Transmit FIFO - HDLC Channel 1 (Write)

	7		0	
XFIFO	XF7		XF0	(00)
XFIFO	XF15		XF8	(01)

Writing data to XFIFO of HDLC channel 1 can be done in 8-bit (byte) or 16-bit (word) access. The LSB is transmitted first.

Up to 32 bytes/16 words of transmit data can be written to the XFIFO following an XPR interrupt.

Command Register (Write)

Value after reset: 00_H

	7		0						
CMDR	RMC	RRES	XREP	XRES	XHF	XTF	XME	SRES	(02)

RMC **Receive Message Complete - HDLC Channel 1**

Confirmation from CPU to FALC56 that the current frame or data block has been fetched following an RPF or RME interrupt, thus the occupied space in the RFIFO can be released. If RMC is given while RFIFO is already cleared, the next incoming data block is cleared instantly, although interrupts are generated.

RRES **Receiver Reset**

The receive line interface except the clock and data recovery unit (DPLL), the receive framer, the one-second timer and the receive signaling controller are reset. However the contents of the control registers is not deleted.

XREP **Transmission Repeat - HDLC Channel 1**

If XREP is set together with XTF (write 24H to CMDR), the FALC56 repeatedly transmits the contents of the XFIFO (1 to 32 bytes) without HDLC framing fully transparently, i.e. without flag, CRC.

The cyclic transmission is stopped with an SRES command or by resetting XREP.

Note: During cyclic transmission the XREP-bit has to be set with every write operation to CMDR.

- XRES Transmitter Reset**
- The transmit framer and transmit line interface excluding the system clock generator and the pulse shaper are reset. However the contents of the control registers is not deleted.
- XHF Transmit HDLC Frame - HDLC Channel 1**
- After having written up to 32 bytes to the XFIFO, this command initiates the transmission of a HDLC frame.
- XTF Transmit Transparent Frame - HDLC Channel 1**
- Initiates the transmission of a transparent frame without HDLC framing.
- XME Transmit Message End - HDLC Channel 1**
- Indicates that the data block written last to the transmit FIFO completes the current frame. The FALC56 can terminate the transmission operation properly by appending the CRC and the closing flag sequence to the data.
- SRES Signaling Transmitter Reset - HDLC Channel 1**
- The transmitter of the signaling controller is reset. XFIFO is cleared of any data and an abort sequence (seven 1s) followed by interframe time fill is transmitted. In response to XRES an XPR interrupt is generated.
- This command can be used by the CPU to abort a frame currently in transmission.
- Note: The maximum time between writing to the CMDR register and the execution of the command takes 2.5 periods of the current system data rate. Therefore, if the CPU operates with a very high clock rate in comparison with the FALC56's clock, it is recommended that bit SIS.CEC should be checked before writing to the CMDR register to avoid any loss of commands.
- Note: If SCLKX is used to clock the transmission path, commands to the HDLC transmitter should only be sent while this clock is available. If SCLKX is missing, the command register is blocked after an HDLC command is given.

Mode Register (Read/Write)

Value after reset: 00_H

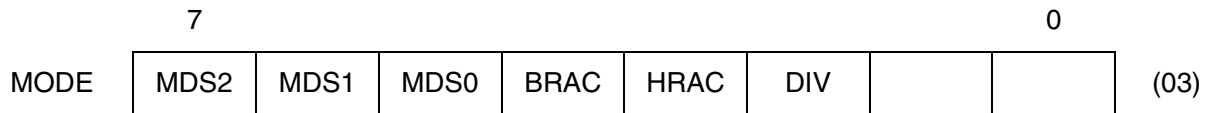

MDS(2:0) Mode Select - HDLC Channel 1

The operating mode of the HDLC controller is selected.

- 000 =Reserved
- 001 =Signaling System 7 (SS7) support¹⁾
- 010 =One-byte address comparison mode (RAL1, 2)
- 011 =Two-byte address comparison mode (RAH1, 2 and RAL1, 2)
- 100 =No address comparison
- 101 =One-byte address comparison mode (RAH1, 2)
- 110 =Reserved
- 111 =No HDLC framing mode 1

BRAC BOM Receiver Active - HDLC Channel 1

Switches the BOM receiver to operational or inoperational state.

- 0 = Receiver inactive
- 1 = Receiver active

HRAC Receiver Active - HDLC Channel 1

Switches the HDLC receiver to operational or inoperational state.

- 0 = Receiver inactive
- 1 = Receiver active

DIV Data Inversion - HDLC Channel 1

Setting this bit inverts the internal generated HDLC channel 1 data stream.

- 0 = Normal operation, HDLC data stream not inverted
- 1 = HDLC data stream inverted

¹⁾ CCR2.RADD must be set, if SS7 mode is selected

Receive Address Byte High Register 1 (Read/Write)

Value after reset: FD_H

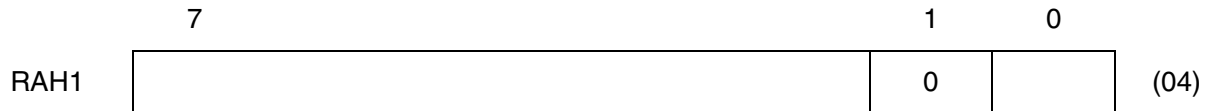

In operating modes that provide high byte address recognition, the high byte of the received address is compared to the individually programmable values in RAH1 and RAH2. The address registers are used by all HDLC channels in common.

RAH1 Value of the First Individual High Address Byte

Bit 1 (C/R-bit) is excluded from address comparison.

Receive Address Byte High Register 2 (Read/Write)

Value after reset: FF_H

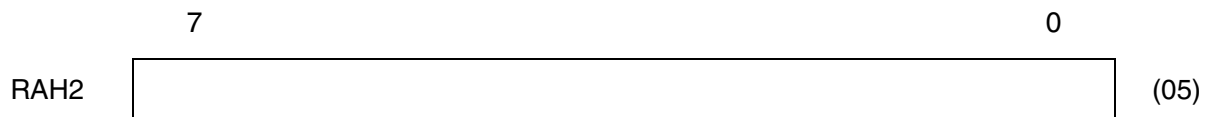

RAH2 Value of Second Individual High Address Byte

Receive Address Byte Low Register 1 (Read/Write)

Value after reset: FF_H

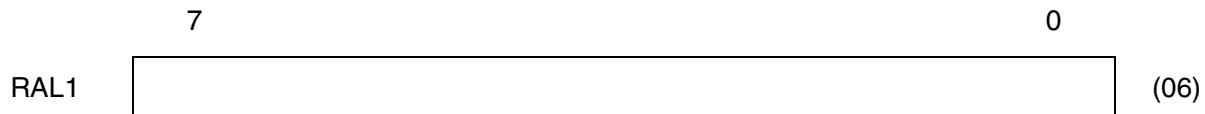

RAL1 Value of First Individual Low Address Byte

Receive Address Byte Low Register 2 (Read/Write)

Value after reset: FF_H

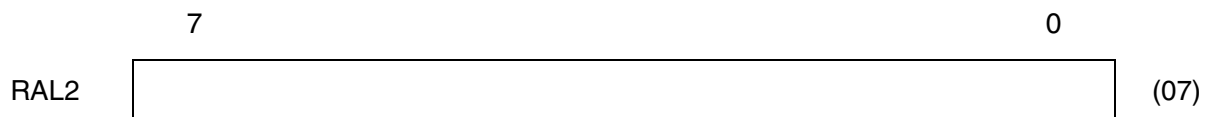

RAL2 Value of the second individually programmable low address byte.

Interrupt Port Configuration (Read/Write)

Value after reset: 00_H



Unused bits have to be cleared.

SSYF Select SYNC Frequency

Only applicable in master mode (LIM0.MAS = 1) and bit CMR2.DCF is cleared.

0 = Reference clock on port SYNC is 1.544/2.048 MHz
(see LIM1.DCOC)

1 = Reference clock on port SYNC is 8 kHz

IC0, IC1 Interrupt Port Configuration

These bits define the function of the interrupt output stage (pin INT):

IC1	IC0	Function
X	0	Open drain output
0	1	Push/pull output, active low
1	1	Push/pull output, active high

Common Configuration Register 1 (Read/Write)

Value after reset: 00_H

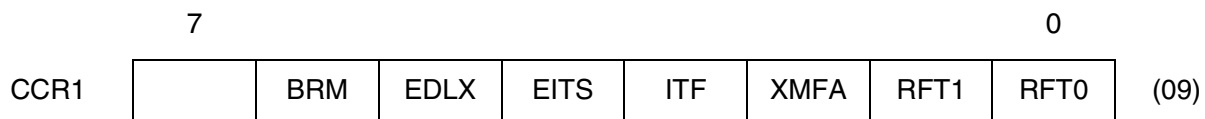

BRM BOM Receive Mode - HDLC Channel 1

(significant in BOM mode only)

0 = 10-byte packets

1 = Continuous reception

EDLX Enable DL-Bit Access through the Transmit FIFO - HDLC Channel 1

A one in this bit position enables the internal DL-bit access through the receive/transmit FIFO of the signaling controller. FMR1.EDL has to be cleared.

- EITS** **Enable Internal Time Slot 0 to 31 Signaling - HDLC Channel 1**
- 0 = Internal signaling in time slots 0 to 31 defined by registers RTR(4:1) or TTR(4:1) is disabled.
- 1 = Internal signaling in time slots 0 to 31 defined by registers RTR(4:1) or TTR(4:1) is enabled.
- ITF** **Interframe Time Fill - HDLC Channel 1**
- Determines the idle (= no data to be sent) state of the transmit data coming from the signaling controller.
- 0 = Continuous logical 1 is output
- 1 = Continuous flag sequences are output (01111110 bit patterns)
- XMFA** **Transmit Multiframe Aligned - HDLC Channel 1**
- Determines the synchronization between the framer and the corresponding signaling controller.
- 0 = The contents of the XFIFO is transmitted without multiframe alignment.
- 1 = The contents of the XFIFO is transmitted multiframe aligned. If CCR1.EDLX is set, transmission of DL-bits is started in F72 format with frame 26. The first byte in XFIFO is transmitted in the first time slot selected by TTR(4:1) and so on. After receiving a complete multiframe in the time slot mode (RTR(4:1)) an ISR0.RME interrupt is generated, if no HDLC or BOM mode is enabled. In DL-bit access (CCR1.EDLX/EITS = 10) XMFA is not valid.
- Note: During the transmission of the XFIFO content, the $\overline{\text{SYPX}}$ or XMFS interval time should not be changed, otherwise the XFIFO data has to be retransmitted.

RFT(1:0)

RFIFO Threshold Level - HDLC Channel 1

The size of the accessible part of RFIFO can be determined by programming these bits. The number of valid bytes after an RPF interrupt is given in the following table:

RFT1	RFT0	Size of Accessible Part of RFIFO
0	0	32 bytes (reset value)
0	1	16 bytes
1	0	4 bytes
1	1	2 bytes

The value of RFT 1,0 can be changed dynamically

- If reception is not running or
- after the current data block has been read, but before the command CMDR.RMC is issued (interrupt controlled data transfer).

Note: It is seen that changing the value of RFT1,0 is possible even during the reception of one frame. The total length of the received frame can be always read directly in RBCL, RBCH after an RPF interrupt, except when the threshold is increased during reception of that frame. The real length can then be inferred by noting which bit positions in RBCL are reset by an RMC command (see **table below**):

RFT1	RFT0	Bit Positions in RBCL Reset by a CMDR.RMC Command
0	0	RBC(4:0)
0	1	RBC(3:0)
1	0	RBC(1:0)
1	1	RBC0

Common Configuration Register 2 (Read/Write)

Value after reset: 00_H

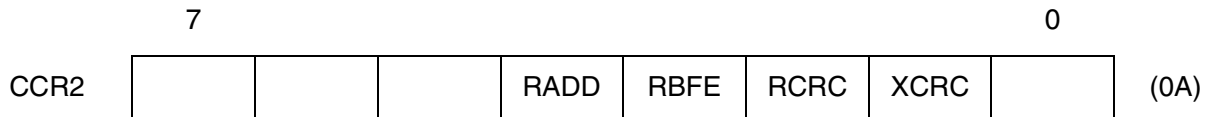

Unused bits have to be cleared.

RADD Receive Address Pushed to RFIFO - HDLC Channel 1
If this bit is set, the received HDLC address information (1 or 2 bytes, depending on the address mode selected by MODE.MDS0) is pushed to RFIFO. This function is applicable in non-auto mode and transparent mode 1. RADD must be set, if SS7 mode is selected.

RBF E Receive BOM Filter Enable - HDLC Channel 1
Setting this bit the bit oriented message (BOM) receiver only accepts BOM frames after detecting 7 out of 10 equal BOM pattern. The BOM pattern is stored in the RFIFO adding a receive status byte marking a BOM frame (RSIS.HFR) and an interrupt ISR0.RME is generated. The current state of the BOM receiver is indicated in register SIS.IVB. When the valid BOM pattern disappears an interrupt ISR0.BIV is generated.

RCRC Receive CRC on/off - HDLC Channel 1
Only applicable in non-auto mode.
If this bit is set, the received CRC checksum is written to RFIFO (CRC-ITU-T: 2 bytes). The checksum, consisting of the 2 last bytes in the received frame, is followed in the RFIFO by the status information byte (contents of register RSIS). The received CRC checksum is additionally checked for correctness. If non-auto mode is selected, the limits for “valid frame” check are modified (refer to RSIS.VFR).

XCRC Transmit CRC on/off - HDLC Channel 1
If this bit is set, the CRC checksum is not generated internally. It has to be written as the last two bytes in the transmit FIFO (XFIFO). The transmitted frame is closed automatically with a closing flag.
Note: The FALC56 does not check whether the length of the frame, i.e., the number of bytes to be transmitted, makes sense or not.

Receive Time Slot Register 1 to 4 (Read/Write)

Value after reset: 00_H, 00_H, 00_H, 00_H

	7							0	
RTR1	TS0	TS1	TS2	TS3	TS4	TS5	TS6	TS7	(0C)
RTR2	TS8	TS9	TS10	TS11	TS12	TS13	TS14	TS15	(0D)
RTR3	TS16	TS17	TS18	TS19	TS20	TS21	TS22	TS23	(0E)
RTR4	TS24	TS25	TS26	TS27	TS28	TS29	TS30	TS31	(0F)

TS(31:0)

Time Slot Register

These bits define the received time slots on the system highway port RDO to be extracted. Additionally these registers control the RSIGM marker which can be forced high during the corresponding time slots independently of bit CCR1.EITS.

A one in the RTR(4:1) bits samples the corresponding time slot in the RFIFO of the signaling controller, if bit CCR1.EITS is set.

Assignments:

SIC2.SSC2 = 0: (32 time slots/frame)

TS0 → time slot 0, TS31 → time slot 31

SIC2.SSC2 = 1: (24 time slots/frame)

TS0 → time slot 0, TS23 → time slot 23

0 = The corresponding time slot is not extracted and stored in the RFIFO.

1 = The contents of the selected time slot is stored in the RFIFO. Although the idle time slots can be selected. This function is only active, if bits CCR1.EITS is set.

The corresponding time slot is forced high on pin RSIGM.

Transmit Time Slot Register 1 to 4 (Read/Write)

Value after reset: 00_H, 00_H, 00_H, 00_H

	7							0	
TTR1	TS0	TS1	TS2	TS3	TS4	TS5	TS6	TS7	(10)
TTR2	TS8	TS9	TS10	TS11	TS12	TS13	TS14	TS15	(11)
TTR3	TS16	TS17	TS18	TS19	TS20	TS21	TS22	TS23	(12)
TTR4	TS24	TS25	TS26	TS27	TS28	TS29	TS30	TS31	(13)

TS(31:0)

Transmit Time Slot Register

These bits define the transmit time slots on the system highway to be inserted. Additionally these registers control the XSIGM marker which can be forced high during the corresponding time slots independently of bit CCR1.EITS.

A one in the TTR(4:1) bits inserts the corresponding time slot sourced by the XFIFO in the data received on pin XDI, if bit CCR1.EITS is set. If SIC3.TTRF is set and CCR1.EDLX/EITS = 00, insertion of data received on port XSIG is controlled by this registers.

Assignments:

SIC2.SSC2 = 0: (32 time slots/frame)

TS0 → time slot 0, TS31 → time slot 31

SIC2.SSC2 = 1: (24 time slots/frame)

TS0 → time slot 0, TS23 → time slot 23

0 = The selected time slot is not inserted into the outgoing data stream.

1 = The contents of the selected time slot is inserted into the outgoing data stream from XFIFO. This function is only active, if bits CCR1.EITS is set.

The corresponding time slot are forced high on marker pin XSIGM.

Interrupt Mask Registers

Value after reset: FF_H, FF_H, FF_H, FF_H, FF_H

	7							0	
IMR0	RME	RFS	ISF	RMB	RSC	CRC6	PDEN	RPF	(14)
IMR1	CASE	RDO	ALLS	XDU	XMB	SUEX	XLSC	XPR	(15)
IMR2	FAR	LFA	MFAR	LMFA	AIS	LOS	RAR	RA	(16)
IMR3	ES	SEC			LLBSC		RSN	RSP	(17)
IMR4	XSP	XSN	RME2	RFS2	RDO2	ALLS2	XDU2	RPF2	(18)
IMR5	XPR2	XPR3	RME3	RFS3	RDO3	ALLS3	XDU3	RPF3	(19)

IMR(5:0) Interrupt Mask Register

Each interrupt source can generate an interrupt signal on port INT (characteristics of the output stage are defined by register IPC). A “1” in a bit position of IMR(5:0) sets the mask active for the interrupt status in ISR(5:0). Masked interrupt statuses neither generate a signal on INT, nor are they visible in register GIS. Moreover, they are

- not displayed in the Interrupt Status Register if bit GCR.VIS is cleared
- displayed in the Interrupt Status Register if bit GCR.VIS is set

After reset, all interrupts are **disabled**.

Single Bit Defect Insertion Register (Read/Write)

Value after reset: 00_H

IERR			IFASE	IMFE	ICRCE	ICASE	IPE	IBV	(1B)
------	--	--	-------	------	-------	-------	-----	-----	------

After setting the corresponding bit, the selected defect is inserted into the transmit data stream at the next possible position. After defect insertion is completed, the bit is reset automatically.

- IFASE** **Insert single FAS defect**
- IMFE** **Insert single multiframe defect**
- ICRCE** **Insert single CRC defect**
- ICASE** **Insert single CAS defect**
- IPE** **Insert single PRBS defect**
- IBV** **Insert bipolar violation**

Note: Except for CRC defects, CRC checksum calculation is done after defect insertion.

Framer Mode Register 0 (Read/Write)

Value after reset: 00_H

	7							0	
FMR0	XC1	XC0	RC1	RC0	FRS	SRAF	EXLS	SIM	(1C)

XC(1:0) Transmit Code

Serial line code for the transmitter, independent of the receiver.

- 00 = NRZ (optical interface)
- 01 = CMI (1T2B+B8ZS), (optical interface)
- 10 = AMI coding with Zero Code Suppression (ZCS, B7-stuffing).
Disabling of the ZCS is done by activating the clear channel mode by register CCB(3:1). (ternary or digital interface)
- 11 = B8ZS Code (ternary or digital dual-rail interface).

After changing XC(1:0), a transmitter software reset is required (CMDR.XRES = 1).

RC(1:0) Receive Code

Serial code receiver is independent to the transmitter.

00 = NRZ (optical interface)

01 = CMI (1T2B+B8ZS), (optical interface)

10 = AMI coding with Zero Code Suppression (ZCS, B7-stuffing),
(ternary or digital dual-rail interface)

11 = B8ZS Code (ternary or digital dual-rail interface)

After changing RC(1:0), a receiver software reset is required
(CMDR.RRES = 1).

FRS**Force Resynchronization**

A transition from low to high forces the frame aligner to execute a resynchronization of the pulse frame. In the asynchronous state, a new frame position is assumed at the next candidate if there is one. Otherwise, a new frame search with the meaning of a general reset is started. In the synchronous state this bit has the same meaning as bit FMR0.EXLS except if FMR2.MCSP = 1.

SRAF**Select Remote (Yellow) Alarm Format for F12 and ESF Format**

0 = F12: bit2 = 0 in every channel. ESF: pattern
"1111 1111 0000 0000" in data link channel.

1 = F12: FS-bit of frame 12. ESF: bit2 = 0 in every channel

EXLS**External Loss Of Frame**

With a low to high transition a new frame search is started. This has the meaning of a general reset of the internal frame alignment unit. Synchronous state is reached only if there is one definite framing candidate. In the case of multiple candidates, the setting of the bit FMR0.FRS forces the receiver to lock onto the next available framing position.

SIM**Alarm Simulation**

Setting/resetting this bit initiates internal error simulation of: AIS (blue alarm), loss-of-signal (red alarm), loss of frame alignment, remote (yellow) alarm, slip, framing errors, CRC errors, code violations. The error counters FEC, CVC, CEC, EBC are incremented.

The selection of simulated alarms is done by the error simulation counter: FRS2.ESC(2:0) which is incremented with each setting of bit FMR0.SIM. For complete checking of the alarm indications eight simulation steps are necessary (FRS2.ESC(2:0) = 0 after a complete simulation).

SIM has to be held stable at high or low level for at least one receive clock period before changing it again.

Framer Mode Register 1 (Read/Write)

Value after reset: 00_H

	7						0		
FMR1	CTM		EDL	PMOD	CRC	ECM	SSD0	XAIS	(1D)

CTM

Channel Translation Mode

- 0 = Channel translation mode 0
- 1 = Channel translation mode 1

The different channel translation modes are described in [Table 30](#) on [page 131](#).

EDL

Enable DL-Bit Access through Register XDL(3:1)

Only applicable in F4, F24 or F72 frame format.

- 0 = Normal operation. The DL-bits are taken from system highway or if enabled by CCR1.EDLX from the XFIFO of the signaling controller.
- 1 = DL-bit register access. The DL-bit information are taken from the registers XDL(3:1) and overwrite the DL-bits received on the system highway (pin XDI) or from the internal XFIFO of the signaling controller. However, transmission of the contents of registers XDL(3:1) is disabled if transparent mode is enabled (FMR4.TM).

PMOD

PCM Mode

For E1 application this bit must be set low. Switching from E1 to T1 or vice versa the device needs up to 20 μs to settle up to the internal clocking.

- 0 = PCM 30 or E1 mode.
- 1 = PCM 24 or T1/J1 mode (see RC0.SJR for T1/J1 selection).

CRC

Enable CRC6

This bit is only significant when using the ESF format.

- 0 = CRC6 check/generation disabled. For transmit direction, all CRC bit positions are set.
- 1 = CRC6 check/generation enabled.

ECM**Error Counter Mode**

The function of the error counters (FEC,CEC,CVC,EBC) is determined by this bit.

0 = Before reading an error counter the corresponding bit in the Disable Error Counter register (DEC) has to be set. In 8 bit access the low byte of the error counter should always be read before the high byte. The error counters are reset with the rising edge of the corresponding bits in the DEC register.

1 = Every second the error counter is latched and then automatically reset. The latched error counter state should be read within the next second. Reading the error counter during updating should be avoided (do not access an error counter within 1 μ s after the one-second interrupt occurs).

SSD0**Select System Date Rate 0**

SIC1.SSD1, FMR1.SSD0 and SIC2.SSC2 define the data rate on the system highway. Programming SSD1/SSD0 and corresponding data rate is shown below.

SIC2.SSC2 = 0:

00 = 2.048 Mbit/s

01 = 4.096 Mbit/s

10 = 8.192 Mbit/s

11 = 16.384 Mbit/s

SIC2.SSC2 = 1:

00 = 1.544 Mbit/s

01 = 3.088 Mbit/s

10 = 6.176 Mbit/s

11 = 12.352 Mbit/s

XAIS**Transmit AIS Towards Remote End**

Sends AIS (blue alarm) on ports XL1, XL2 towards the remote end.

If Local Loop Mode is enabled the transmitted data is looped back to the system internal highway without any changes.

Framer Mode Register 2 (Read/Write)

Value after reset: 00_H

	7							0	
FMR2		MCSP	SSP	DAIS	SAIS	PLB	AXRA	EXZE	(1E)

MCSP Multiple Candidates Synchronization Procedure

SSP Select Synchronization/Resynchronization Procedure

Together with bit FMR2.SSP the synchronization mode of the receive framer is defined:

MCSP/SSP:

00 = F12/F72 format:

Specified number of errors in both FT framing and FS framing lead to loss of sync (FRS0.LFA is set). In the case of FS-bit framing errors, bit FRS0.LMFA is set additionally. A complete new synchronization procedure is initiated to regain pulseframe alignment and then multiframe alignment.

F24:

normal operation: synchronization is achieved only on verification the framing pattern.

01 = F12/F72:

Specified number of errors in FT framing has the same effect as above. Specified number of errors in FS framing only initiates a new search for multiframe alignment without influencing pulseframe synchronous state (FRS0.LMFA is set).

F24:

Synchronous state is reached when three consecutive multiframe pattern are correctly found independent of the occurrence of CRC6 errors.

10 = F12/F24:

A one enables a synchronization mode which is able to choose multiple framing pattern candidates step by step. I.e. if in synchronous state the CRC error counter indicates that the synchronization might have been based on an alias framing pattern, setting of FMR0.FRS leads to synchronization on the next candidate available. However, only the previously assumed candidate is discarded in the internal framing pattern memory. The latter procedure can be repeated until the framer locks on the right pattern (no extensive CRC errors). Therefore bit FMR1.CRC must be set.

T1/J1 Registers

11 = F24:

Synchronization is achieved on verification the framing pattern **and** the CRC6 bits. Synchronous state is reached when framing pattern and CRC6 checksum are correctly found. For correct operation the CRC check must be enabled by setting bit FMR1.CRC.

DAIS**Disable AIS to System Interface**

0 = AIS is automatically inserted into the data stream to RDO if FALC56 is in asynchronous state.

1 = Automatic AIS insertion is disabled. Furthermore, AIS insertion can be initiated by programming bit FMR2.SAIS.

SAIS**Send AIS Towards System Interface**

Sends AIS (blue alarm) on output RDO towards system interface. This function is not influenced by bit FMR2.DAIS.

PLB**Payload Loop-Back**

0 = Normal operation. Payload loop is disabled.

1 = The payload loop-back loops the data stream from the receiver section back to transmitter section. Looped data is output on pin RDO. Data received on port XDI, XSIG, SYPX and XMFS is ignored. With FMR4.TM = 1 all 193 bits per frame are looped back. If FMR4.TM = 0 the DL- or FS- or CRC-bits are generated internally. AIS is sent immediately on port RDO by setting the FMR2.SAIS bit. During payload loop is active the receive time slot offset (registers RC(1:0)) should not be changed. It is recommended to write the actual value of XC1 into this register once again, because a write access to register XC1 sets the read/write pointer of the transmit elastic buffer into its optimal position to ensure a maximum wander compensation (the write operation forces a slip).

AXRA**Automatic Transmit Remote Alarm**

0 = Normal operation

1 = The remote alarm (yellow alarm) bit is set automatically in the outgoing data stream if the receiver is in asynchronous state (FRS0.LFA bit is set). In synchronous state the remote alarm bit is reset.

EXZE Excessive Zeros Detection Enable

Selects error detection mode in the bipolar receive bit stream.

0 = Only bipolar violations are detected.

1 = Bipolar violations and zero strings of 8 or more contiguous zeros in B8ZS code or more than 15 contiguous zeros in AMI code are detected additionally and counted in the code violation counter CVC.

LOOP (Read/Write)

Value after reset: 00_H

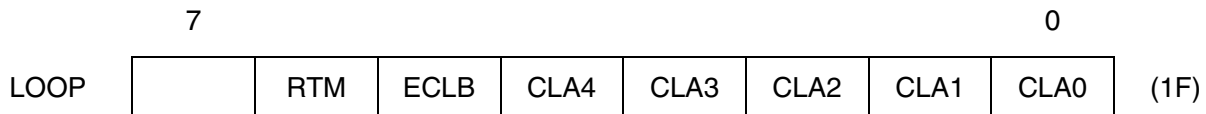

RTM Receive Transparent Mode

Setting this bit disconnects control of the internal elastic store from the receiver. The elastic store is now in a “free running” mode without any possibility to actualize the time slot assignment to a new frame position in case of resynchronization of the receiver. This function can be used together with the “disable AIS to system interface” feature (FMR2.DAIS) to realize undisturbed transparent reception.

This bit should be enabled in case of unframed data reception mode.

ECLB Enable Channel Loop-Back

0 = Disables the channel loop-back.

1 = Enables the channel loop-back selected by this register.

Note: CAS-BR must be switched off (FMR5.EIBR = 0) while channel loop back is enabled.

CLA(4:0) Channel Address For Loop-Back

CLA = 1 to 24 selects the channel.

During loop-back, the contents of the associated outgoing channel on ports XL1/XDOP/XOID and XL2/XDON is equal to the idle channel code programmed in register IDLE.

Framer Mode Register 4 (Read/Write)

Value after reset: 00_H

	7							0	
FMR4	AIS3	TM	XRA	SSC1	SSC0	AUTO	FM1	FM0	(20)

AIS3

Select AIS Condition

- 0 = AIS (blue alarm) is indicated (FRS0.AIS) when two or less zeros in the received bit stream are detected in a time interval of 12 frames (F4, F12, F72) or 24 frames (ESF).
- 1 = AIS (blue alarm) detection is only enabled when FALC56 is in asynchronous state. The alarm is indicated (FRS0.AIS) when
 - three or less zeros within a time interval of 12 frames (F4, F12, F72), or
 - five or less zeros within a time interval of 24 frames (ESF) are detected in the received bit stream.

TM

Transparent Mode

Setting this bit enables the transparent mode:

In transmit direction bit 8 of every FS/DL time slot from the system internal highway (XDI) is inserted in the F-bit position of the outgoing frame. Internal framing generation, insertion of CRC and DL data is disabled.

XRA

Transmit Remote Alarm (Yellow Alarm)

If high, remote alarm is sent on the PCM route. Clearing the bit removes the remote alarm pattern. Remote alarm indication depends on the multiframe structure as follows:

- F4: Bit2 = 0 in every speech channel
- F12: – FMR0.SRAF = 0: bit2 = 0 in every speech channel
 – FMR0.SRAF = 1: FS-bit of frame 12 is forced to “1”
- ESF: – FMR0.SRAF = 0: pattern
 “1111111100000000 11111111000”
 in data link channel
 – FMR0.SRAF = 1: bit2 = 0 in every speech channel
- F72: Bit2 = 0 in every speech channel

SSC(1:0)**Select Sync Conditions**

Loss of Frame Alignment (FRS0.LFA or opt. FRS0.LMFA) is declared if:

00 = 2 out of 4 framing bits

01 = 2 out of 5 framing bits

10 = 2 out of 6 framing bits in F4/12/72 format

10 = 2 out of 6 framing bits per multiframe period in ESF format

11 = 4 consecutive multiframe pattern in ESF format

are incorrect. It depends on the selected multiframe format and optionally on bit FMR2.SSP which framing bits are observed:

F4: FT-bits → FRS0.LFA

F12, F72:SSP = 0:

FT-bits → FRS0.LFA

FS-bits → FRS0.LFA and FRS0.LMFA

F12, F72:SSP = 1:

FT → FRS0.LFA

FS → FRS0.LMFA

ESF: ESF framing bits → FRS0.LFA

AUTO**Enable Auto Resynchronization**

0 = The receiver does not re synchronize automatically. Starting a new synchronization procedure is possible by the bits FMR0.EXLS or FMR0.FRS.

1 = Auto-resynchronization is enabled.

FM(1:0)**Select Frame Mode**

FM = 0: 12-frame multiframe format (F12, D3/4)

FM = 1: 4-frame multiframe format (F4)

FM = 2: 24-frame multiframe format (ESF)

FM = 3: 72-frame multiframe format (F72, remote switch mode)

Framer Mode Register 5 (Read/Write)

Value after reset: 00_H

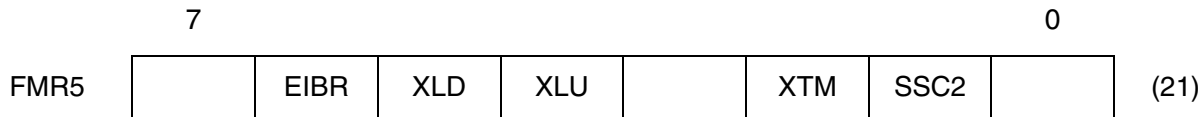

- EIBR** **Enable Internal Bit Robbing Access**
 0 = Normal operation.
 1 = A one in this bit position causes the transmitter to send the bit robbing signaling information stored in the XS(12:1) (ESF, F12, 72) registers or serial CAS in the corresponding time slots.
- XLD** **Transmit Line Loop-Back (LLB) Down Code**
 0 = Normal operation.
 1 = A one in this bit position causes the transmitter to replace normal transmit data with the LLB down (deactivate) Code continuously until this bit is reset. The LLB down code is overwritten by the framing/DL/CRC bits optionally.
- XLU** **Transmit LLB Up Code**
 0 = Normal operation.
 1 = A one in this bit position causes the transmitter to replace normal transmit data with the LLB up (activate) code continuously until this bit is reset. The LLB up code is optionally overwritten by the framing/DL/CRC bits. For proper operation bit FMR5.XLD must be cleared.
- XTM** **Transmit Transparent Mode**
 0 = Ports $\overline{\text{SYPX}}/\text{XMFS}$ define the frame/multiframe begin on the transmit system highway. The transmitter is usually synchronized on this externally sourced frame boundary and generates the FS/DL-bits according to this framing. Any change of the transmit time slot assignment subsequently produces a change of the FS/DL-bit positions.
 1 = Disconnects the control of the transmit system interface from the transmitter. The transmitter is now in a free running mode without any possibility to actualize the multiframe position. The framing (FS/DL-bits) generated by the transmitter are not “disturbed” (in case of changing the transmit time slot assignment) by the transmit system highway unless register XC1 is written. This bit should be set if loop-timed application is

T1/J1 Registers

selected. For proper operation the transmit elastic buffer (2 frames, SIC1.XBS(1:0) = 10) has to be enabled.

SSC2 Select Sync Conditions

Only valid in ESF framing format.
Loss of Frame Alignment FRS0.LFA is declared if more than 320 CRC6 errors per second interval are detected.

Transmit Control 0 (Read/Write)

Value after reset: 00_H

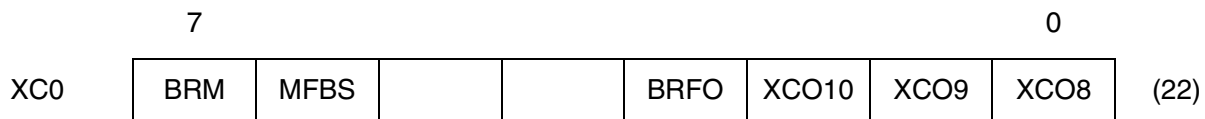

BRM Enable Bit Robbing Marker
A one in this bit marks the robbed bit positions on the system highway. RSIGM marks the receive and XSIGM marks the transmit robbed bits.

MFBS Enable pure Multiframe Begin Signals
Only valid if ESF or F72 format is selected.
0 = RMFB marks the beginning of every received superframe. Additional pulses are provided every 12 frames when using ESF/F24 or F72 format.
1 = RMFB marks the beginning of every received multiframe.

BRFO Bit Robbing Force One
Setting this bit forces the robbed bits high transmitted on port RDO. The received signaling data stream for the signaling controller is not influenced by this bit.

XCO(10:8) Transmit Offset
Initial value loaded into the transmit bit counter at the trigger edge of SCLKX when the synchronous pulse on port $\overline{\text{SYPX}}$ or XMFS is active Refer to register XC1.

Transmit Control 1 (Read/Write)

Value after reset: 9C_H

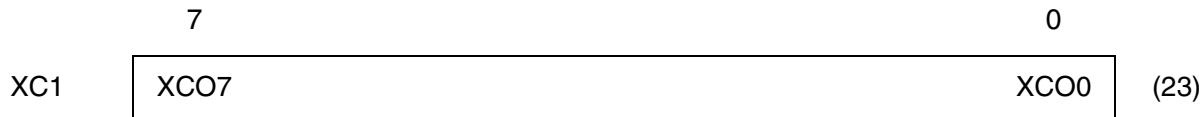

A write access to this address resets the transmit elastic buffer to its basic starting position. Therefore, updating the value should only be done when the FALC56 is initialized or when the buffer should be centered. As a consequence a transmit slip will occur.

XCO(7:0)

Transmit Offset

Initial value loaded into the transmit bit counter at the trigger edge of SCLKX when the synchronous pulse on port $\overline{\text{SYPX}}/\text{XMFS}$ is active.

Calculation of delay time T (SCLKX cycles) depends on the value X of the transmit offset register XC(1:0):

system clocking rate: modulo 2.048 MHz (SIC2.SSC2 = 0)

0 ≤ T ≤ 4: X = 4 - T

5 ≤ T ≤ maximum delay: X = 256 × SC/SD - T + 4)

with maximum delay = (256 × SC/SD) - 1

with SC = system clock defined by SIC1.SSC(1:0)+SIC2.SSC2

with SD = 2.048 Mbit/s (system clocking n × 2.048 MHz)

or

system clocking rate: modulo 1.544 MHz (SIC2.SSC2 = 1)

0 ≤ T ≤ 4: X = 3 - T + 7 × SC/BF

5 ≤ T ≤ maximum delay: X = 200 × SC/BF - T + 3

with SC = system clock defined by SIC1.SSC(1:0)+SIC2.SSC2

SD = 1.544 Mbit/s (system clocking n × 1.544 MHz)

with BF = basic frequency = 1.544 MHz

T = Time between the active edge of SCLKX after $\overline{\text{SYPX}}$ pulse begin and beginning of the next frame (F-bit, channel phase 0), measured in number of SCLKX clock intervals; maximum delay:

$$T_{\max} = (200 \times \text{SC}/\text{BF}) - (7 \times \text{SC}/\text{BF}) - 1$$

See [page 178](#) for further description.

Receive Control 0 (Read/Write)

Value after reset: 00_H

	7						0		
RC0	SJR	RRAM	CRCI	XCRCI	RDIS	RCO10	RCO9	RCO8	(24)

SJR Select Japanese ITU-T Requirements

- 0 = T1: Alarm handling is done according ITU-T G. 704+706
- 1 = J1: Alarm handling is done according ITU-T JG. 704+706

RRAM Receive Remote Alarm Mode

The conditions for remote (yellow) alarm (FRS0.RRA) detection can be selected by this bit to allow detection even in the presence of a bit error rate of up to 10^{-3} :

RRAM = 0

Detection

- F4: Bit2 = 0 in every speech channel per frame.
- F12: – FMR0.SRAF = 0: bit2 = 0 in every speech channel per frame.
– FMR0.SRAF = 1: S-bit of frame 12 is forced to “1”
- ESF: – FMR0.SRAF = 0: pattern “1111 1111 0000 0000” in data link channel
– FMR0.SRAF = 1: bit2 = 0 in every speech channel
- F72: Bit2 = 0 in every speech channel per frame.

Release: The alarm is reset when above conditions are no longer detected.

RRAM = 1 (bit error rate 10^{-3})

Detection

- F4: Bit2 = 0 in 255 consecutive speech channels.
- F12: – FMR0.SRAF = 0: bit 2 = 0 in 255 consecutive speech channels.
– FMR0.SRAF = 1: S-bit of frame 12 is forced to “1”
- ESF: – FMR0.SRAF = 0: pattern “1111 1111 0000 0000” in data link channel
– FMR0.SRAF = 1: bit 2 = 0 in 255 consecutive speech channels
- F72: Bit 2 = 0 in 255 consecutive speech channels.

Release

Depending on the selected multiframe format the alarm is reset when FALC56 does not detect

- the "bit 2 = 0" condition for three consecutive pulse frames (all formats if selected),
- the "FS-bit" condition for three consecutive multiframes (F12),
- the "DL pattern" for three times in a row (ESF).

CRCI**Automatic CRC6 Bit Inversion**

If set, all CRC bits of one outgoing extended multiframe are inverted in case a CRC error is flagged for the previous received multiframe. This function is logically ored with RC0.XCRCI.

XCRCI**Transmit CRC6 Bit Inversion**

If set, the CRC bits in the outgoing data stream are inverted before transmission. This function is logically ored with RC0.CRCI.

RDIS**Receive Data Input Sense**

Digital interface, dual-rail:

0 = Inputs RDIP/RDIN are active low

1 = Inputs RDIP/RDIN are active high

Digital Interface, CMI:

0 = Input ROID is active high

1 = Input ROID is active low

RCO(10:8)**Receive Offset/Receive Frame Marker Offset**

Depending on the $\overline{RP(A\text{ to }D)}$ pin function different offsets can be programmed. The \overline{SYPR} and the RFM pin function cannot be selected in parallel.

Receive Offset (PC(4:1).RPC(2:0) = 000)

Initial value loaded into the receive bit counter at the trigger edge of SCLKR when the synchronous pulse on port \overline{SYPR} is active.

Calculation of delay time T (SCLKR cycles) depends on the value X of the receive offset register RC(1:0). Refer to register RC1.

Receive Control 1 (Read/Write)

Value after reset: $9C_H$

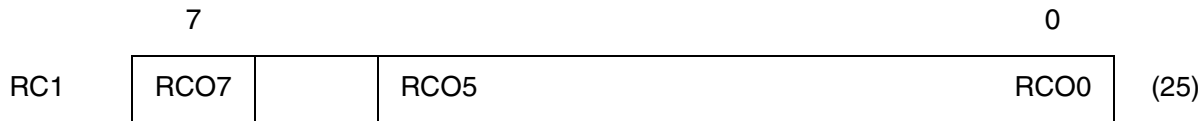

RCO(7:0)

Receive Offset/Receive Frame Marker Offset

Depending on the RP(A to D) pin function different offsets can be programmed. The \overline{SYPR} and the RFM pin function cannot be selected in parallel.

Receive Offset (PC(4:1).RPC(2:0) = 000)

Initial value loaded into the receive bit counter at the trigger edge of SCLKR when the synchronous pulse on port \overline{SYPR} is active.

Calculation of delay time T (SCLKR cycles) depends on the value X of the receive offset register RC(1:0):

system clocking rate: modulo 2.048 MHz (SIC2.SSC2 = 0)

$$0 \leq T \leq 4: X = 4 - T$$

$$5 \leq T \leq \text{maximum delay}: X = 2052 - T$$

with maximum delay = $(256 \times SC/SD) - 1$

with SC = system clock defined by SIC1.SSC(1:0)+SIC2.SSC2

with SD = system data rate

or

system clocking rate: modulo 1.544 MHz (SIC2.SSC2 = 1)

$$0 \leq T \leq 4: X = 4 - T + (7 \times SC/SD)$$

$$5 \leq T \leq \text{maximum delay}: X = (200 \times SC/SD) + 4 - T$$

with maximum delay = $193 \times SC/SD - 1$

with SC = system clock defined by SIC1.SSC(1:0)+SIC2.SSC2

with SD = system data rate

Delay time T = time between beginning of time slot 0 at RDO and the initial edge of SCLKR after \overline{SYPR} goes active.

See [page 168](#) for further description.

T1/J1 Registers

Receive Frame Marker Offset (PC(4:1).RPC(2:0) = 001_B)

Offset programming of the receive frame marker which is output on multifunction port RFM. The receive frame marker can be activated during any bit position of the entire frame and depends on the selected system clock rate.

Calculation of the value X of the receive offset register RC(1:0) depends on the bit position which should be marked at marker position MP:

system clocking rate: modulo 2.048 MHz (SIC2.SSC2 = 0)

$$0 \leq MP \leq 2045: X = MP + 2$$

$$2046 \leq MP \leq 2047: X = MP - 2046$$

e.g: 2.048 MHz: MP = 0 to 255; 4.096 MHz: MP = 0 to 511,

8.192 MHz: MP = 0 to 1023, 16.384 MHz: MP = 0 to 2047

system clocking rate: modulo 1.544 MHz (SIC2.SSC2 = 1)

$$0 \leq MP \leq 193 \times (SC/SD) - 3: X = MP + 2 + 7 \times SC/SD$$

$$193 \times (SC/SD) - 2 \leq MP \leq \text{maximum delay}: X = MP + 2 - 186 \times SC/SD$$

with maximum delay = $193 \times SC/SD - 1$

with SC = system clock defined by SIC1.SSC(1:0)+SIC2.SSC2

with SD = system data rate

Transmit Pulse-Mask Registers (Read/Write)

Value after reset: 7B_H, 03_H, 40_H

	7						0		
XPM0	XP12	XP11	XP10	XP04	XP03	XP02	XP01	XP00	(26)
XPM1	XP30	XP24	XP23	XP22	XP21	XP20	XP14	XP13	(27)
XPM2	0	XLT	DAXLT		XP34	XP33	XP32	XP31	(28)

The transmit pulse shape which is defined in ANSI T1.102 is output on pins XL1 and XL2. The level of the pulse shape can be programmed by registers XPM(2:0) to create a custom waveform. In order to get an optimized pulse shape for the external transformers each pulse shape is internally divided into four sub pulse shapes. In each sub pulse shape a programmed 5 bit value defines the level of the analog voltage on pins XL1/2. Together four 5 bit values have to be programmed to form one complete transmit pulse shape. The four 5 bit values are sent in the following sequence:

- XP04 to 00: First pulse shape level
- XP14 to 10: Second pulse shape level
- XP24 to 20: Third pulse shape level
- XP34 to 30: Fourth pulse shape level

Changing the LSB of each subpulse in registers XPM(2:0) changes the amplitude of the differential voltage on XL1/2 by approximately 80 mV.

The XPM values in the following table are based on simulations. They are valid for the following external circuitry: transformer ratio 1:2.4, cable PULB 22AWG (100Ω), serial resistors 2Ω. Adjustment of these coefficients can be necessary for other external conditions.

Table 64 Pulse Shaper Programming (T1/J1)

Range in m	Range in ft.	XPM0	XPM1	XPM2	XP04-XP00	XP14-XP10	XP24-XP20	XP34-XP30
		hexadecimal			decimal			
0 to 40	0 to 133	D7	22	1	23	22	8	2
40 to 81	133 to 266	FA	26	1	26	23	9	2
81 to 122	266 to 399	3D	37	1	29	25	13	2
122 to 162	399 to 533	5F	3F	1	31	26	15	2
162 to 200	533 to 655	3F	CB	1	31	25	18	3

XLT Transmit Line Tristate

- 0 = Normal operation
- 1 = Transmit line XL1/XL2 or XDOP/XDON are switched into high-impedance state. If this bit is set the transmit line monitor status information is frozen (default value after hardware reset).

DAXLT Disable Automatic Tristating of XL1/2

- 0 = Normal operation. If a short is detected on pins XL1/2 the transmit line monitor sets the XL1/2 outputs into a high-impedance state.
- 1 = If a short is detected on pins XL1/2, the automatic setting of these pins into a high-impedance state (by the XL-monitor) is disabled.

Idle Channel Code Register (Read/Write)

Value after reset: 00_H

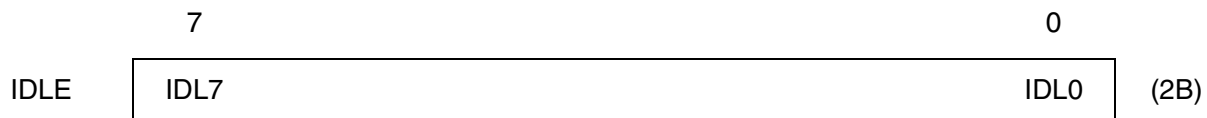

IDL(7:0) Idle Channel Code

If channel loop-back is enabled by programming the register LOOP.ECLB = 1, the contents of the assigned outgoing channel on ports XL1/XL2 or XDOP/XDON is set equal to the idle channel code selected by this register.

Additionally, the specified pattern overwrites the contents of all channels of the outgoing PCM frame selected by the idle channel registers ICB(3:1). IDL7 is transmitted first.

Transmit DL-Bit Register 1-3 (Read/Write)

Value after reset: 00_H, 00_H, 00_H

7									0	
XDL1	XDL17	XDL16	XDL15	XDL14	XDL13	XDL12	XDL11	XDL10		(2C)
XDL2	XDL27	XDL26	XDL25	XDL24	XDL23	XDL22	XDL21	XDL20		(2D)
XDL3	XDL37	XDL36	XDL35	XDL34	XDL33	XDL32	XDL31	XDL30		(2E)

XDL(3:1) Transmit FS/DL-Bit Data

The DL-bit register access is enabled by setting bits FMR1.EDL = 1. With the transmit multiframe begin an interrupt ISR1.XMB is generated and the contents of these registers XDL(3:1) is copied into a shadow register. The contents is subsequently sent out in the data stream of the next outgoing multiframe if no transparent mode is enabled. XDL10 is sent out first.

In F4 frame format only XDL10+XDL11 are transmitted. In F24 frame format XDL10 to 23 are shifted out. In F72 frame format XDL10 to 37 are transmitted.

The transmit multiframe begin interrupt (XMB) requests that these registers should be serviced. If requests for new information are ignored, the current contents is repeated.

Clear Channel Register (Read/Write)

Value after reset: 00_H, 00_H, 00_H

	7							0	
CCB1	CH1	CH2	CH3	CH4	CH5	CH6	CH7	CH8	(2F)
CCB2	CH9	CH10	CH11	CH12	CH13	CH14	CH15	CH16	(30)
CCB3	CH17	CH18	CH19	CH20	CH21	CH22	CH23	CH24	(31)

CH(24:1) Channel Selection Bits

0 = Normal operation. Bit robbing information and zero code suppression (ZCS, B7 stuffing) can change contents of the selected speech/data channel if assigned modes are enabled by bits FMR5.EIBR and FMR0.XC(1:0).

1 = Clear channel mode. Contents of selected speech/data channel are not overwritten by internal or external bit robbing and ZCS information. Transmission of channel assigned signaling and control of pulse-density is applied by the user.

Idle Channel Register (Read/Write)

Value after reset: 00_H, 00_H, 00_H, 00_H

	7							0	
ICB1	IC1	IC2	IC3	IC4	IC5	IC6	IC7	IC8	(32)
ICB2	IC9	IC10	IC11	IC12	IC13	IC14	IC15	IC16	(33)
ICB3	IC17	IC18	IC19	IC20	IC21	IC22	IC23	IC24	(34)

IC(24:1) Idle Channel Selection Bits

These bits define the channels (time slots) of the outgoing PCM frame to be altered.

- 0 = Normal operation.
- 1 = Idle channel mode. The contents of the selected channel is overwritten by the idle channel code defined by register IDLE.

Line Interface Mode 0 (Read/Write)

Value after reset: 00_H

	7							0	
LIM0	XFB	XDOS			EQON	RLM	LL	MAS	(36)

XFB Transmit Full Bauded Mode

Only applicable for dual-rail mode (bit LIM1.DRS = 1).

- 0 = Output signals XDOP/XDON are half bauded (normal operation).
- 1 = Output signals XDOP/XDON are full bauded.

Note: If CMI coding is selected (FMR0.XC(1:0) = 01) this bit has to be cleared.

XDOS

Transmit Data Out Sense

0 = Output signals XDOP/XDON are active low. Output XOID is active high (normal operation).

1 = Output signals XDOP/XDON are active high. Output XOID is active low.

Note: If CMI coding is selected (FMR0.XC(1:0) = 01) this bit has to be cleared.

The transmit frame marker XFM is independent of this bit.

EQON

Receive Equalizer On

0 = -10 dB receiver: short-haul mode

1 = -36 dB receiver: long-haul mode

RLM

Receive Line Monitoring

0 = Normal receiver mode

1 = Receiver mode for receive line monitoring; the receiver sensitivity is increased to detect resistively attenuated signals of -20 dB (short-haul mode only)

LL

Local Loop

0 = Normal operation

1 = Local loop active. The local loop-back mode disconnects the receive lines RL1/RL2 or RDIP/RDIN from the receiver. Instead of the signals coming from the line the data provided by system interface is routed through the analog receiver back to the system interface. The unipolar bit stream is transmitted undisturbedly on the line. Receiver and transmitter coding must be identical. Operates in analog and digital line interface mode. In analog line interface mode data is transferred through the complete analog receiver.

MAS

Master Mode

0 = Slave mode

1 = Master mode on. Setting this bit the DCO-R circuitry is frequency synchronized to the clock (1.544, 2.048 MHz or 8 kHz, see IPC.SSYF, LIM1.DCOC) supplied by SYNC. If this pin is connected to V_{SS} or V_{DD} (or left open and pulled up to V_{DD} internally) the DCO-R circuitry is centered and no receive jitter attenuation is performed (only if 1.544 or 2.048 MHz clock is selected by resetting bit IPC.SSYF). The generated clocks are stable.

Line Interface Mode 1 (Read/Write)

Value after reset: 00_H

	7						0		
LIM1	CLOS	RIL2	RIL1	RIL0	DCOC	JATT	RL	DRS	(37)

CLOS Clear data in case of LOS

- 0 = Normal receiver mode, receive data stream is transferred normally in long-haul mode
- 1 = In long-haul mode received data is cleared (driven low), as soon as LOS is detected

RIL(2:0) Receive Input Threshold

Only valid if analog line interface is selected (LIM1.DRS = 0).
 “No signal” is declared if the voltage between pins RL1 and RL2 drops below the limits programmed by bits RIL(2:0) and the received data stream has no transition for a period defined in the PCD register. The threshold where “no signal” is declared is programmable by the RIL(2:0) bits depending on bit LIM0.EQON.
 Note: LIM1.RIL(2:0) must be programmed before LIM0.EQON = 1 is set.
 See the DC characteristics for detail.

DCOC DCO-R Control

- 0 = 1.544 MHz reference clock for the DCO-R circuitry provided on pin SYNC.
 - 1 = 2.048 MHz reference clock for the DCO-R circuitry provided on pin SYNC.
- Note: If IPC.SSYF = 1, external reference clock frequency is 8.0 kHz independent of DCOC.

JATT, RL

Remote Loop Transmit Jitter Attenuator

00 = Normal operation. The remote loop transmit jitter attenuator is disabled. Transmit data bypasses the remote loop jitter attenuator buffer.

01 = Remote Loop active without transmit jitter attenuator enabled. Transmit data bypasses the remote loop jitter attenuator buffer.

10 = not assigned

11 = Remote Loop and remote loop jitter attenuator active. Received data from pins RL1/2 or RDIP/N or ROID is sent "jitter-free" on ports XL1/2 or XDOP/N or XOID. The de-jittered clock is generated by the DCO-X circuitry.

Note: JATT is only used to define the jitter attenuation during remote loop operation. Jitter attenuation during normal operation is not affected.

DRS

Dual-Rail Select

0 = The ternary interface is selected. Multifunction ports RL1/2 and XL1/2 become analog in/outputs.

1 = The digital dual-rail interface is selected. Received data is latched on multifunction ports RDIP/RDIN while transmit data is output on pins XDOP/XDON.

Pulse Count Detection Register (Read/Write)

Value after reset: 00_H

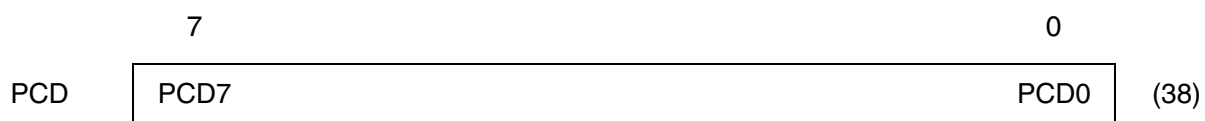

PCD(7:0)

Pulse Count Detection

A LOS alarm (red alarm) is detected if the incoming data stream has no transitions for a programmable number T consecutive pulse positions. The number T is programmable by the PCD register and can be calculated as follows:

$$T = 16 \times (N+1); \text{ with } 0 \leq N \leq 255.$$

The maximum time is: $256 \times 16 \times 648 \text{ ns} = 2.65 \text{ ms}$. Every detected pulse resets the internal pulse counter. The counter is clocked with the receive clock RCLK.

Pulse Count Recovery (Read/Write)

Value after reset: 00_H

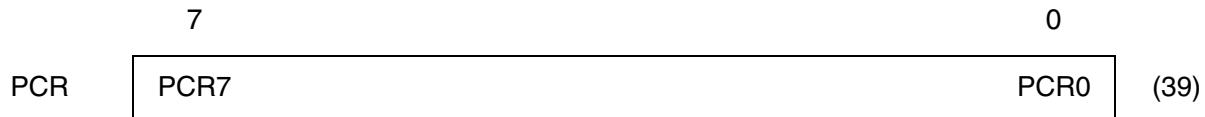

PCR(7:0)

Pulse Count Recovery

A LOS alarm (red alarm) is cleared if a pulse-density is detected in the received bit stream. The number of pulses M which must occur in the predefined PCD time interval is programmable by the PCR register and can be calculated as follows:

$$M = N+1; \text{ with } 0 \leq N \leq 255.$$

The time interval starts with the first detected pulse transition. With every received pulse a counter is incremented and the actual counter is compared to the contents of PCR register. If the pulse number reaches or exceeds the PCR value the LOS alarm is reset otherwise the alarm stays active. In this case the next detected pulse transition starts a new time interval.

An additional loss-of-signal recovery condition is selected by register LIM2.LOS1.

Line Interface Mode 2 (Read/Write)

Value after reset: 20_H

	7						0	
LIM2	LBO2	LBO1	SLT1	SLT0	SCF	ELT		LOS1 (3A)

LBO(2:1)

Line Build-Out

In long-haul applications LIM0.EQON = 1 a transmit filter can be optionally placed on the transmit path to attenuate the data on pins XL1/2. Selecting the transmitter attenuation is possible in steps of 7.5 dB at 772kHz which is according to FCC68 and ANSI T1.403.

To meet the line build-out defined by ANSI T1.403 registers XPM(2:0) should be programmed as follows:

- 00 = 0 dB
- 01 = 7.5 dB →XPM(2:0) = 20_H, 02_H, 51_H
- 10 = -15 dB →XPM(2:0) = 20_H, 01_H, 51_H
- 11 = -22.5 dB →XPM(2:0) = 20_H, 01_H, 50_H

SLT(1:0)

Receive Slicer Threshold

- 00 = The receive slicer generates a mark (digital one) if the voltage at RL1/2 exceeds 55% of the peak amplitude.
- 01 = The receive slicer generates a mark (digital one) if the voltage at RL1/2 exceeds 67% of the peak amplitude (may be used in some T1/J1 applications).
- 10 = The receive slicer generates a mark (digital one) if the voltage at RL1/2 exceeds 50% of the peak amplitude (default, recommended in T1/J1 mode).
- 11 = The receive slicer generates a mark (digital one) if the voltage at RL1/2 exceeds 45% of the peak amplitude.

SCF

Select Corner Frequency of DCO-R

Setting this bit reduces the corner frequency of the DCO-R circuit by the factor of ten to 0.6 Hz.

Note: Reducing the corner frequency of the DCO-R circuitry increases the synchronization time before the frequencies are synchronized.

ELT Enable Loop-Timed

0 = Normal operation

1 = Transmit clock is generated from the clock supplied by MCLK which is synchronized to the extracted receive route clock. In this configuration the transmit elastic buffer has to be enabled. Refer to register FMR5.XTM. For correct operation of loop timed the remote loop (bit LIM1.RL = 0) must be inactive and bit CMR1.DXSS must be cleared.

LOS1 Loss-of-Signal Recovery condition

0 = The LOS alarm is cleared if the predefined pulse-density (register PCR) is detected during the time interval which is defined by register PCD.

1 = Additionally to the recovery condition described above a LOS alarm is only cleared if the pulse-density is fulfilled and no more than 15 contiguous zeros are detected during the recovery interval (according to GR-499-CORE).

Loop Code Register 1 (Read/Write)

Value after reset: 00_H

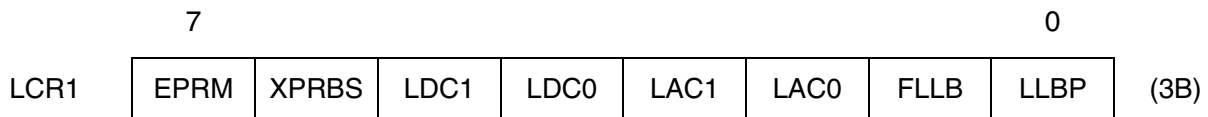

EPRM Enable Pseudo-Random Binary Sequence Monitor

0 = Pseudo-random binary sequence (PRBS) monitor is disabled.

1 = PRBS is enabled. Setting this bit enables incrementing the bit error counter BEC with each detected PRBS bit error. With any change of state of the PRBS internal synchronization status an interrupt ISR3.LLBSC is generated. The current status of the PRBS synchronizer is indicated by bit FRS1.LLBAD.

XPRBS Transmit Pseudo-Random Binary Sequence

A one in this bit position enables transmission of a pseudo-random binary sequence to the remote end. Depending on bit LLBP the PRBS is generated according to $2^{15} - 1$ or $2^{20} - 1$ (ITU-T O. 151).

- LDC(1:0) Length Deactivate (Down) Code**
 These bits defines the length of the LLB deactivate code which is programmable in register LCR2.
 00 = Length: 5 bit
 01 = Length: 6 bit, 2 bit, 3 bit
 10 = Length: 7 bit
 11 = Length: 8 bit, 2 bit, 4bit
- LAC(1:0) Length Activate (Up) Code**
 These bits defines the length of the LLB activate code which is programmable in register LCR3.
 00 = Length: 5 bit
 01 = Length: 6 bit, 2 bit, 3 bit
 10 = Length: 7 bit
 11 = Length: 8 bit, 2 bit, 4bit
- FLLB Framed Line Loop-Back/Invert PRBS**
 Depending on bit LCR1.XPRBS this bit enables different functions:
 LCR1.XPRBS = 0:
 0 = The line loop-back code is transmitted including framing bits. LLB code overwrites the FS/DL-bits.
 1 = The line loop-back code is transmitted unframed. LLB code does not overwrite the FS/DL-bits.
- Invert PRBS**
 LCR1.XPRBS = 1:
 0 = The generated PRBS is transmitted not inverted.
 1 = The PRBS is transmitted inverted.
- LLBP Line Loop-Back Pattern**
 LCR1.XPRBS = 0
 0 = Fixed line loop-back code according to ANSI T1. 403.
 1 = Enable user-programmable line loop-back code by register LCR2/3.
 LCR1.XPRBS = 1 or LCR1.EPRM = 1
 0 = $2^{15} - 1$
 1 = $2^{20} - 1$

Loop Code Register 2 (Read/Write)

Value after reset: 00_H

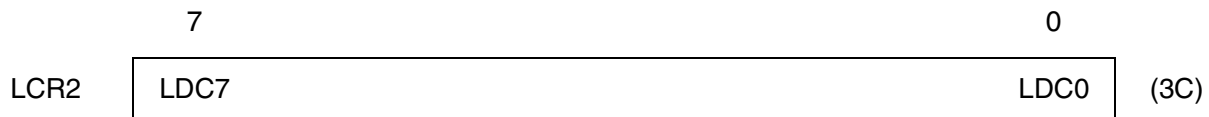

LDC(7:0) Line Loop-Back Deactivate Code

If enabled by bit FMR5.XLD = 1 the LLB deactivate code automatically repeats until the LLB generator is stopped. Transmit data is overwritten by the LLB code. LDC0 is transmitted last. For correct operations bit LCR1.XPRBS has to cleared.

If LCR2 is changed while the previous deactivate code has been detected and is still received, bit FRS1.LLBDD will stay active until the incoming signal changes or a receiver reset is initiated (CMDR.RRES = 1).

Loop Code Register 3 (Read/Write)

Value after reset: 00_H

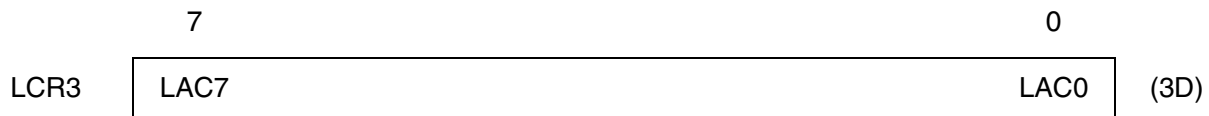

LAC(7:0) Line Loop-Back Activate Code

If enabled by bit FMR5.XLU = 1 the LLB activate code automatically repeats until the LLB generator is stopped. Transmit data is overwritten by the LLB code. LAC0 is transmitted last. For correct operations bit LCR1.XPRBS has to cleared.

If LCR3 is changed while the previous activate code has been detected and is still received, bit FRS1.LLBAD will stay active until the incoming signal changes or a receiver reset is initiated (CMDR.RRES = 1).

System Interface Control 1 (Read/Write)

Value after reset: 00_H

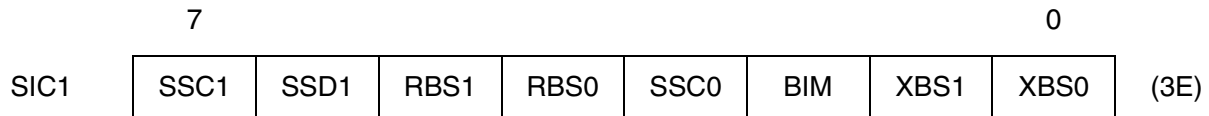

SSC(1:0)

Select System Clock

SIC1.SSC(1:0) and SIC2.SSC2 define the clocking rate on the system highway.

SIC2.SSC2 = 0:

00 = 2.048 MHz

01 = 4.096 MHz

10 = 8.192 MHz

11 = 16.384 MHz

SIC2.SSC2 = 1:

00 = 1.544 MHz

01 = 3.088 MHz

10 = 6.176 MHz

11 = 12.352 MHz

SSD1

Select System Data Rate 1

SIC1.SSD1, FMR1.SSD0 and SIC2.SSC2 define the data rate on the system highway. Programming SSD1/SSD0 and corresponding data rate is shown below.

SIC2.SSC2 = 0:

00 = 2.048 Mbit/s

01 = 4.096 Mbit/s

10 = 8.192 Mbit/s

11 = 16.384 Mbit/s

SIC2 .SSC2 = 1:

00 =1.544 Mbit/s

01 = 3.088 Mbit/s

10 = 6.176 Mbit/s

11 = 12.352 Mbit/s

RBS(1:0)

Receive Buffer Size

- 00 = Buffer size: 2 frames
- 01 = Buffer size: 1 frame
- 10 = Buffer size: 96 bits
- 11 = Bypass of receive elastic store

BIM

Bit Interleaved Mode

Only applicable if bit SIC2.SSC2 is cleared. If SIC2.SSC2 is set high, the bit interleaved mode is automatically performed.

- 0 = Byte interleaved mode
- 1 = Bit interleaved mode

XBS(1:0)

Transmit Buffer Size

- 00 = Bypass of transmit elastic store
- 01 = Buffer size: 1 frame
- 10 = Buffer size: 2 frames
- 11 = Buffer size: 96 bits

System Interface Control 2 (Read/Write)

Value after reset: 00_H

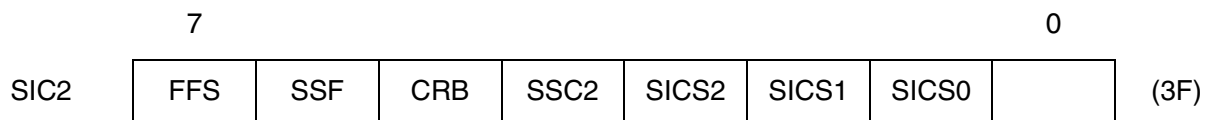

FFS

Force Freeze Signaling

Setting this bit disables updating of the receive signaling buffer and current signaling information is frozen. After resetting this bit and receiving a complete superframe updating of the signaling buffer is started again. The freeze signaling status can also be generated automatically by detection of a loss-of-signal alarm or a loss of frame alignment or a receive slip (only if external register access through RSIG is enabled). This automatic freeze signaling function is logically or'ed with this bit.

The current internal freeze signaling status is output on pin RP(A to D) with selected pin function FREEZE (PC(4:1).RPC(2:0) = 110). Additionally this status is also available in register SIS.SFS.

- SSF** **Serial Signaling Format**
Only applicable if pin function RSIG/XSIG and SIC3.TTRF = 0 is selected.
0 = Bits 1 to 4 in all time slots except time slot 0 are cleared.
1 = Bits 1 to 4 in all time slots except time slot 0 are set high.
- CRB** **Center Receive Elastic Buffer**
Only applicable if the time slot assigner is disabled (PC(4:1).RPC(2:0) = 001_B), no external or internal synchronous pulse receive is generated.
A transition from low to high forces a receive slip and the read pointer of the receive elastic buffer is centered. The delay through the buffer is set to one half of the current buffer size. It should be hold high for at least two 1.544 MHz periods before it is cleared.
- SSC2** **Select System Clock**
This bit together with SIC1.SSC1/0 enables the system interface to run with a clock of 1.544, 3.088, 6.176 or 12.352 MHz (SSC2 = 1) or 2.048, 4.096, 8.192 or 16.384 MHz (SSC2 = 0).
See also register SIC1.SSC1/0 on [page 373](#).
- SICS(2:0)** **System Interface Channel Select**
Only applicable if the system clock rate is greater than 1.544/2.048MHz.
Received data is transmitted on pin RDO/RSIG or received on XD/XSIG with the selected system data rate. If the data rate is greater than 1.544/2.048 Mbit/s the data is output or sampled in half, a quarter or one eighth of the time slot. Data is not repeated. The time while data is active during a 8 × 488/648 ns time slot is called a channel phase. RDO/RSIG are cleared (driven to low level) while XD/XSIG are ignored for the remaining time of the 8 × 488/648 ns for the remaining channel phases. The channel phases are selectable with these bits.
000 = Data active in channel phase 1, valid if system data rate is 16/8/4 or 12/6/3 Mbit/s
001 = Data active in channel phase 2, valid if data rate is 16/8/4 or 12/6/3 Mbit/s
010 = Data active in channel phase 3, valid if data rate is 16/8 or 12/6 Mbit/s
011 = Data active in channel phase 4, valid if data rate is 16/8 or 12/6 Mbit/s

T1/J1 Registers

- 100 = Data active in channel phase 5, valid if data rate is 16 or 12 Mbit/s
- 101 = Data active in channel phase 6, valid if data rate is 16 or 12 Mbit/s
- 110 = Data active in channel phase 7, valid if data rate is 16 or 12 Mbit/s
- 111 = Data active in channel phase 8, valid if data rate is 16 or 12 Mbit/s

System Interface Control 3(Read/Write)

Value after reset: 00_H

	7							0	
SIC3	CMI				RESX	RESR	TTRF	DAF	(40)

CMI

Select CMI Precoding

Only valid if CMI code (FMR0.XC(1:0) = 01) is selected. This bit defines the CMI precoding and influences transmit and receive data.

- 0 = CMI with B8ZS precoding
- 1 = CMI without B8ZS precoding

Note: Before local loop is closed, B8ZS precoding has to be switched off.

RESX

Rising Edge Synchronous Pulse Transmit

Depending on this bit all transmit system interface data and marker are clocked or sampled with the selected active edge.

CMR2.IXSC = 0:

- 0 latched with the first falling edge of the selected PCM highway clock.
- 1 latched with the first rising edge of the selected PCM highway clock.

CMR2.IXSC = 1:

value of RESX bit has no impact on the selected edge of the PCM highway clock but value of $\overline{\text{RESR}}$ bit is used as RESX.

Example: If RESR = 0, the rising edge of PCM highway clock is the selected one for sampling data on XDI and vice versa.

- RESR** **Rising Edge Synchronous Pulse Receive**
- Depending on this bit all receive system interface data and marker are clocked with the selected active edge.
- 0 = Latched with the first falling edge of the selected PCM highway clock.
 - 1 = Latched with the first rising edge of the selected PCM highway clock.
- Note: If bit CMR2.IRSP is set, the behavior of signal RFM (if used) is inverse (1 = falling edge, 0 = rising edge)
- TTRF** **TTR Register Function (Fractional T1/J1 Access)**
- Setting this bit the function of the TTR(4:1) registers are changed. A one in each TTR register forces the XSIGM marker high for the corresponding time slot and controls sampling of the time slots provided on pin XSIG. XSIG is selected by PC(4:1).XPC(3:0).
- DAF** **Disable Automatic Freeze**
- 0 = Signaling is automatically frozen if one of the following alarms occurred: Loss-Of-signal (FRS0.LOS), Loss-of-Frame-Alignment (FRS0.LFA), or receive slips (ISR3.RSP/N).
 - 1 = Automatic freezing of signaling data is disabled. Updating of the signaling buffer is also done if one of the above described alarm conditions is active. However, updating of the signaling buffer is stopped if SIC2.FFS is set. Significant only if the serial signaling access is enabled.

Clock Mode Register 1 (Read/Write)

Value after reset: 00_H

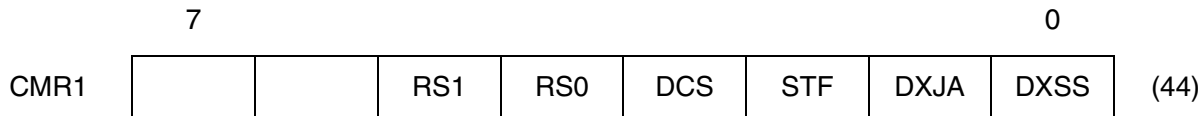

RS(1:0)

Select RCLK Source

These bits select the source of RCLK.

- 00 = Clock recovered from the line through the DPLL drives RCLK
- 01 = Clock recovered from the line through the DPLL drives RCLK and in case of an active LOS alarm RCLK pin is set high.
- 10 = Clock recovered from the line is de-jittered by DCO-R to drive a 2.048 MHz (SIC2.SSC2 = 0) or 1.544 MHz (SIC2.SSC2 = 1) clock on RCLK.
- 11 = Clock recovered from the line is de-jittered by DCO-R to drive a 8.192 MHz (SIC2.SSC2 = 0) or 6.176 MHz (SIC2.SSC2 = 1) clock on RCLK.

DCS

Disable Clock-Switching

In Slave mode (LIM0.MAS = 0) the DCO-R is synchronized on the recovered route clock. In case of LOS the DCO-R switches automatically to the clock sourced by port SYNC. Setting this bit automatic switching from RCLK to SYNC is disabled.

STF

Select TCLK Frequency

Only applicable if the pin function TCLK port XP(A to D) is selected by PC(4:1).XPC(3:0) = 0011_B. Data on XL1/2, XDOP/N, XOID are clocked with TCLK.

- 0 = 1.544 MHz
- 1 = 6.176 MHz

DXJA

Disable Internal Transmit Jitter Attenuation

Setting this bit disables the transmit jitter attenuation. Reading the data out of the transmit elastic buffer and transmitting on XL1/2 (XDOP/N/XOID) is done with the clock provided on pin TCLK. In transmit elastic buffer bypass mode the transmit clock is taken from SCLKX, independent of this bit.

DXSS

DCO-X Synchronization Clock Source

0 = The DCO-X circuitry synchronizes to the internal reference clock which is sourced by SCLKX/R or RCLK. Since there are many reference clock opportunities the following internal prioritizing in descending order from left to right is realized: LIM1.RL > CMR1.DXSS > LIM2.ELT > current working clock of transmit system interface.

If one of these bits is set the corresponding reference clock is taken.

1 = DCO-X synchronizes to an external reference clock provided on pin XP(A to D) pin function TCLK, if no remote loop is active. TCLK is selected by PC(4:1).XPC(3:0) = 0011_B

Clock Mode Register 2 (Read/Write)

Value after reset: 00_H

	7							0	
CMR2			DCOXC	DCF	IRSP	IRSC	IXSP	IXSC	(45)

DCOXC

DCO-X Center-Frequency Enable

0 = The center function of the DCO-X circuitry is disabled.

1 = The center function of the DCO-X circuitry is enabled. DCO-X centers to 1.544 MHz related to the master clock reference (MCLK), if reference clock (e.g. SCLKX) is missing.

DCF

DCO-R Center- Frequency Disabled

0 = The DCO-R circuitry is frequency centered
 - in master mode if no 1.544 or 2.048 MHz reference clock on pin SYNC is provided or
 - in slave mode if a loss-of-signal occurs in combination with no 1.544 or 2.048 MHz clock on pin SYNC or
 - a gapped clock is provided on pin RCLKI and this clock is inactive or stopped.

1 = The center function of the DCO-R circuitry is disabled. The generated clock (DCO-R) is frequency frozen in that moment when no clock is available on pin SYNC or pin RCLKI. The DCO-R circuitry starts synchronization as soon as a clock on pins SYNC or RCLKI appears.

IRSP**Internal Receive System Frame Sync Pulse**

0 = The frame sync pulse for the receive system interface is sourced by $\overline{\text{SYPR}}$ (if $\overline{\text{SYPR}}$ is applied). If $\overline{\text{SYPR}}$ is not applied, the frame sync pulse is derived from RDO output signal internally free running).

The use of IRSP = 0 is recommended.

1 = The frame sync pulse for the receive system interface is internally sourced by the DCO-R circuitry. This internally generated frame sync signal can be output (active low) on multifunction ports RP(A to D) ($\text{RPC}(2:0) = 001_B$).

Note: This is the only exception where the use of RFM and $\overline{\text{SYPR}}$ is allowed at the same time. Because only one set of offset registers (RC1/0) is available, programming is done by using the $\overline{\text{SYPR}}$ calculation formula in the same way as for the external $\overline{\text{SYPR}}$ pulse. Bit IRSC must be set for correct operation.

IRSC**Internal Receive System Clock**

0 = The working clock for the receive system interface is sourced by SCLKR or in receive elastic buffer bypass mode from the corresponding extracted receive clock RCLK.

1 = The working clock for the receive system interface is sourced internally by DCO-R or in bypass mode by the extracted receive clock. SCLKR is ignored.

IXSP**Internal Transmit System Frame Sync Pulse**

0 = The frame sync pulse for the transmit system interface is sourced by $\overline{\text{SYPX}}$.

1 = The frame sync pulse for the transmit system interface is internally sourced by the DCO-R circuitry. Additionally, the external XMFS signal defines the transmit multiframe begin. XMFS is enabled or disabled by the multifunction port configuration. For correct operation bits CMR2.IXSC/IRSC must be set. $\overline{\text{SYPX}}$ is ignored.

IXSC**Internal Transmit System Clock**

0 = The working clock for the transmit system interface is sourced by SCLKX.

1 = The working clock for the transmit system interface is sourced internally by the working clock of the receive system interface. SCLKX is ignored.

Global Configuration Register (Read/Write)

Value after reset: 00_H

	7						0	
GCR	VIS	SCI	SES	ECMC			PD	(46)

- VIS** **Masked Interrupts Visible**
 0 = Masked interrupt status bits are not visible in registers ISR(5:0).
 1 = Masked interrupt status bits are visible in ISR(5:0), but they are not visible in registers GIS.
- SCI** **Status Change Interrupt**
 0 = Interrupts are generated either on activation or deactivation of the internal interrupt source.
 1 = The following interrupts are activated both on activation and deactivation of the internal interrupt source:
 ISR2.LOS, ISR2.AIS and ISR0.PDEN
- SES** **Select External Second Timer**
 0 = Internal second timer selected
 1 = External second timer selected
- ECMC** **Error Counter Mode COFA**
 0 = Not defined; reserved for future applications.
 1 = A Change of Frame or Multiframe Alignment COFA is detected since the last resynchronization. The events are accumulated in the COFA event counter COEC.(1:0).
 Multiframe periods received in the asynchronous state are accumulated in the COFA event counter COEC.(7:2).
 An overflow of each counter is disabled.
- PD** **Power Down**
 Switches between power-up and power-down mode.
 0 = Power up
 1 = Power down
 All outputs are driven inactive, except the multifunction ports, which are weakly driven high by the internal pullup devices.

Errored Second Mask (Read/Write)

Value after reset: FF_H

	7							0	
ESM	LFA	FER	CER	AIS	LOS	CVE	SLIP		(47)

ESM Errored Second Mask

This register functions as an additional mask register for the interrupt status bit Errored Second (ISR3.ES). A "1" in a bit position of ESM deactivates the related second interrupt.

Disable Error Counter (Write)

Value after reset: 00_H

	7							0	
DEC	DRBD		DCOEC	DBEC	DCEC	DEBC	DCVC	DFEC	(60)

DRBD Disable Receive Buffer Delay

This bit has to be set before reading the register RBD. It is automatically reset if RBD has been read.

DCOEC Disable COFA Event Counter

DBEC Disable PRBS Bit Error Counter

Only valid if LCR1.EPRM = 1 and FMR1.ECM are reset.

DCEC Disable CRC Error Counter

DEBC Disable Errored Block Counter

DCVC Disable Code Violation Counter

DFEC Disable Framing Error Counter

These bits are only valid if FMR1.ECM is cleared. They have to be set before reading the error counters. They are reset automatically if the corresponding error counter high byte has been read. With the rising edge of these bits the error counters are latched and then cleared.

Note: Error counters and receive buffer delay can be read 1 μs after setting the according bit in bit DEC.

Transmit Signaling Register (Write)

Value after reset: not defined

Table 65 Transmit Signaling Registers (T1/J1)

	7							0	
XS1	A1	B1	C1/A2	D1/B2	A2/A3	B2/B3	C2/A4	D2/B4	(70)
XS2	A3/A5	B3/B5	C3/A6	D3/B6	A4/A7	B4/B7	C4/A8	D4/B8	(71)
XS3	A5/A9	B5/B9	C5/A10	D5/B10	A6/A11	B6/B11	C6/A12	D6/B12	(72)
XS4	A7/A13	B7/B13	C7/A14	D7/B14	A8/A15	B8/B15	C8/A16	D8/B16	(73)
XS5	A9/A17	B9/B17	C9/A18	D9/B18	A10/A19	B10/B19	C10/A20	D10/B20	(74)
XS6	A11/A21	B11/B21	C11/A22	D11/B22	A12/A23	B12/B23	C12/A24	D12/B24	(75)
XS7	A13/A1	B13/B1	C13/A2	D13/B2	A14/A3	B14/B3	C14/A4	D14/B4	(76)
XS8	A15/A5	B15/B5	C15/A6	D15/B6	A16/A7	B16/B7	C16/A8	D16/B8	(77)
XS9	A17/A9	B17/B9	C17/A10	D17/B10	A18/A11	B18/B11	C18/A12	D18/B12	(78)
XS10	A19/A13	B19/B13	C19/A14	D19/B14	A20/A15	B20/B15	C20/A16	D20/B16	(79)
XS11	A21/A17	B21/B17	C21/A18	D21/B18	A22/A19	B22/B19	C22/A20	D22/B20	(7A)
XS12	A23/A21	B23/B21	C23/A22	D23/B22	A24/A23	B24/B23	C24/A24	D24/B24	(7B)

Transmit Signaling Register 1 to 12

The transmit signaling register access is enabled by setting bit FMR5.EIBR = 1. Each register contains the bit robbing information for 8 DS0 channels. With the transmit CAS empty interrupt ISR1.CASE the contents of these registers is copied into a shadow register. The contents is subsequently sent out in the corresponding bit positions of the next outgoing multiframe. XS1.7 is sent out first in channel 1 frame 1 and XS12.0 is sent out last. The transmit CAS empty interrupt ISR1.CASE requests that these registers should be serviced within the next 3 ms. If requests for new information are ignored, current contents is repeated.

Note: If access to XS(12:1) registers is done without control of the interrupt ISR1.CASE and the write access to these registers is done exact in that moment when this interrupt is generated, data is lost.

A software reset (CMDR.XRES) resets these registers.

Port Configuration 1 to 4 (Read/Write)

Value after reset: 00_H

	7						0		
PC1		RPC12	RPC11	RPC10	XPC13	XPC12	XPC11	XPC10	(80)
PC2		RPC22	RPC21	RPC20	XPC23	XPC22	XPC21	XPC20	(81)
PC3		RPC32	RPC31	RPC30	XPC33	XPC32	XPC31	XPC30	(82)
PC4		RPC42	RPC41	RPC40	XPC43	XPC42	XPC41	XPC40	(83)

RPC(2:0) Receive multifunction port configuration

The multifunction ports RP(A to D) are bidirectional. After Reset these ports are configured as inputs. With the selection of the pin function the In/Output configuration is also achieved. The input function $\overline{\text{SYPR}}$ may only be selected once, it must not be selected twice or more. Register PC1 configures port RPA, while PC2 → port RPB, PC3 → port RPC and PC4 → port RPD.

000 = $\overline{\text{SYPR}}$: Synchronous Pulse Receive (Input)

Together with register RC(1:0) $\overline{\text{SYPR}}$ defines the frame begin on the receive system interface. Because of the offset programming the $\overline{\text{SYPR}}$ and the RFM pin function cannot be selected in parallel.

001 = RFM: Receive Frame Marker (Output)

CMR2.IRSP = 0:

The receive frame marker is active high for one 1.544 MHz period during any bit position of the current frame. Programming of the bit position is done by using registers RC(1:0). The internal time slot assigner is disabled. The RFM offset calculation formula has to be used.

CMR2.IRSP = 1:

Internally generated frame synchronization pulse sourced by the DCO-R circuitry. The pulse is active low for one 1.544 MHz period.

010 = RMFB: Receive Multiframe Begin (Output)

Marks the beginning of every received multiframe or optionally the begin of every CAS multiframe begin (active high).

T1/J1 Registers

- 011 = **RSIGM: Receive Signaling Marker (Output)**
Marks the time slots which are defined by register RTR(4:1) of every frame on port RDO.
- 100 = **RSIG: Receive Signaling Data (Output)**
The received CAS multiframe is transmitted on this pin. Time slot on RSIG correlates directly to the time slot assignment on RDO.
- 101 = **DLR: Data Link Bit Receive (Output)**
Marks the S_a -bits within the data stream on RDO.
- 110 = **FREEZE: Freeze Signaling (Output)**
The freeze signaling status is active high by detecting a Loss-of-signal alarm, or a Loss of CAS Frame Alignment or a receive slip (positive or negative). It stays high for at least one complete multiframe after the alarm disappears. Setting SIC2.FFS enforces a high on pin FREEZE.
- 111 = **$\overline{\text{RFSP}}$: Receive Frame Synchronous Pulse (Output)**
Marks the frame begin in the receivers synchronous state. This marker is active low for 488 ns with a frequency of 8 kHz.

XPC(3:0)

Transmit multifunction Port Configuration

The multifunction ports XP(A to D) are bidirectional. After Reset these ports are configured as inputs. With the selection of the pin function the In/Output configuration is also achieved. Each of the four different input functions ($\overline{\text{SYPX}}$, XMFS, XSIG, TCLK) may only be selected once. No input function must be selected twice or more. $\overline{\text{SYPX}}$ and XMFS should not be selected in parallel. Register PC1 configures port XPA, while PC2 → port XPB, PC3 → port XPC and PC4 → port XPD.

- 0000 = **$\overline{\text{SYPX}}$: Synchronous Pulse Transmit (Input)**
Together with register XC(1:0) $\overline{\text{SYPX}}$ defines the frame begin on the transmit system interface ports XDI and XSIG.
- 0001 = **XMFS: Transmit Multiframe Synchronization (Input)**
Together with register XC(1:0) XMFS defines the frame and multiframe begin on the transmit system interface ports XDI and XSIG. Depending on PC5.CXMFS the signal on XMFS is active high or low.
- 0010 = **XSIG: Transmit Signaling Data (Input)**
Input for transmit signaling data received from the signaling highway. Optionally sampling of XSIG data is controlled by the active high XSIGM marker.

T1/J1 Registers

- 0011 = TCLK: Transmit Clock (Input)
A 1.544/6.176MHz clock has to be sourced by the system if the internal generated transmit clock (DCO-X) is not used. Optionally this input is used as a synchronization clock for the DCO-X circuitry with a frequency of 1.544 or 6.176 MHz.
- 0100 = XMFB: Transmit Multiframe Begin (Output)
Marks the beginning of every transmit multiframe.
- 0101 = XSIGM: Transmit Signaling Marker (Output)
Marks the time slots which are defined by register TTR(4:1) of every frame on port XDI.
- 0110 = DLX: Data Link Bit Transmit (Output)
Marks the S_a-bits within the data stream on XDI.
- 0111 = XCLK: Transmit Line Clock (Output)
Frequency: 1.544MHz
- 1000 = XLT: Transmit Line Tristate (Input)
With a high level on this port the transmit lines XL1/2 or XDOP/N are set directly into tristate. This pin function is logically ored with register XPM2.XLT.

Port Configuration 5 (Read/Write)

Value after reset: 00_H

	7						0		
PC5			CCLK2	CCLK1	CXMFS	0	CSRP	CRP	(84)

CCLK2 Configure CLK2 Port
0 = CLK2 is input
1 = CLK2 is output (only if DCO-X is active)

CCLK1 Configure CLK1 Port
0 = CLK1 is input
1 = CLK1 is output (only if DCO-R is active)

CXMFS Configure XMFS Port
0 = Port XMFS is active low.
1 = Port XMFS is active high.

- PC5(2)** reserved.
Must be cleared
- CSRP** **Configure SCLKR Port**
0 = SCLKR: Input
1 = SCLKR: Output
- CRP** **Configure RCLK Port**
0 = RCLK: Input
1 = RCLK: Output

Global Port Configuration 1 (Read/Write)

Value after reset: 00_H



- CSFP(1:0)** **Configure SEC/FSC Port**
The FSC pulse is generated if the DCO-R circuitry of the selected channel is active (CMR2.IRSC = 1 or CMR1.RS(1:0) = 10_B or 11_B).
- 00 = SEC: Input, active high
 - 01 = SEC: Output, active high
 - 10 = FSC: Output, active high
 - 11 = FSC: Output, active low

Port Configuration 6 (Read/Write)

Value after reset: 00_H

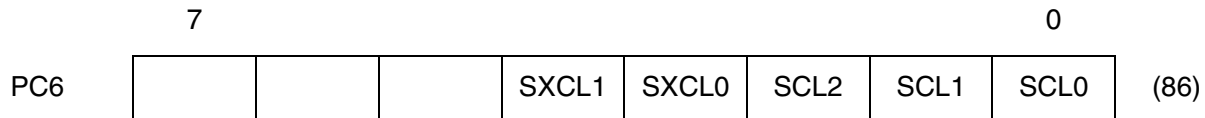

SXCL(1:0) Select Transmit Clock Frequency on Port CLK2

Port CLK2 is the de-jittered DCO-X clock at a frequency of

00 = 1.544 MHz

01 = 3.088MHz

10 = 6.176 MHz

11 = 12.352 MHz

Note: If DCO-X is not used, no clock is output on pin CLK2 (SIC1.XBS(1:0)=00 and CMR1.DXJA=1; buffer bypass and no jitter attenuation)

SCL(2:0) Select System Clock Frequency on Port CLK1

Port CLK1 is the de-jittered DCO-R clock at a frequency of

SIC2.SSC2=0:

000 = 8 kHz

001 = 2.048 MHz

010 = 4.096 MHz

011 = 8.192 MHz

100 = 16.384 MHz

101 to 111 = Not defined

SIC2.SSC2=1:

000 = 8 kHz

001 = 1.544 MHz

010 = 3.088 MHz

011 = 6.176 MHz

100 = 12.352 MHz

101 to 111 = Not defined

Note: If DCO-R is not active, no clock is output on pin CLK1 (SIC1.RBS(1:0)=11 and CMR1.RS1=0).

Command Register 2 (Write)

Value after reset: 00_H

CMDR2							RSUC	XPPR	(87)
-------	--	--	--	--	--	--	------	------	------

RSUC

Reset Signaling Unit Counter - HDLC Channel 1

After setting this bit the SS7 signaling unit counter and error counter are reset. The bit is cleared automatically after execution.

Note: The maximum time between writing to the CMDR2 register and the execution of the command takes 2.5 periods of the current system data rate. Therefore, if the CPU operates with a very high clock rate in comparison with the FALC56's clock, it is recommended that bit SIS.CEC should be checked before writing to the CMDR register to avoid any loss of commands.

XPPR

Transmit Periodical Performance Report (PPR)

After setting this bit the last PPR is sent once. The bit is cleared automatically after completion. Applies to HDLC channel 1 only.

Command Register 3 (Write)

Value after reset: 00_H

	7						0		
CMDR3	RMC2		XREP2		XHF2	XTF2	XME2	SRES2	(88)

RMC2

Receive Message Complete - HDLC Channel 2

Confirmation from CPU to FALC[®] that the current frame or data block has been fetched following an RPF2 or RME2 interrupt, thus the occupied space in the RFIFO2 can be released.

XREP2

Transmission Repeat - HDLC Channel 2

If XREP2 is set together with XTF2 (write 24H to CMDR3), the FALC[®] repeatedly transmits the contents of the XFIFO2 (1 to 32 bytes) without HDLC framing fully transparently, i.e. without flag, CRC.

The cyclic transmission is stopped with an SRES2 command or by resetting XREP2.

- XHF2 Transmit HDLC Frame - HDLC Channel 2**
After having written up to 32 bytes to the XFIFO2, this command initiates the transmission of a HDLC frame.
- XTF2 Transmit Transparent Frame - HDLC Channel 2**
Initiates the transmission of a transparent frame without HDLC framing.
- XME2 Transmit Message End - HDLC Channel 2**
Indicates that the data block written last to the XFIFO2 completes the current frame. The FALC[®] can terminate the transmission operation properly by appending the CRC and the closing flag sequence to the data.
- SRES2 Signaling Transmitter Reset - HDLC Channel 2**
The transmitter of the signaling controller is reset. XFIFO2 is cleared of any data and an abort sequence (seven 1s) followed by interframe time fill is transmitted. In response to SRES2 an XPR2 interrupt is generated.
This command can be used by the CPU to abort a frame currently in transmission.

Command Register 4 (Write)

Value after reset: 00_H

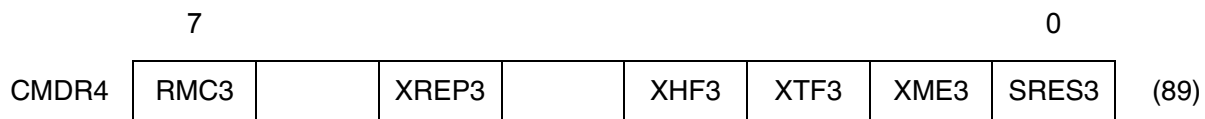

- RMC3 Receive Message Complete - HDLC Channel 3**
Confirmation from CPU to FALC[®] that the current frame or data block has been fetched following an RPF3 or RME3 interrupt, thus the occupied space in the RFIFO3 can be released.
- XREP3 Transmission Repeat - HDLC Channel 3**
If XREP3 is set together with XTF3 (write 24H to CMDR4), the FALC[®] repeatedly transmits the contents of the XFIFO3 (1 to 32 bytes) without HDLC framing fully transparently, i.e. without flag, CRC.
The cyclic transmission is stopped with an SRES3 command or by resetting XREP3.

- XHF3 Transmit HDLC Frame - HDLC Channel 3**
After having written up to 32 bytes to the XFIFO3, this command initiates the transmission of a HDLC frame.
- XTF3 Transmit Transparent Frame - HDLC Channel 3**
Initiates the transmission of a transparent frame without HDLC framing.
- XME3 Transmit Message End - HDLC Channel 3**
Indicates that the data block written last to the XFIFO3 completes the current frame. The FALC[®] can terminate the transmission operation properly by appending the CRC and the closing flag sequence to the data.
- SRES3 Signaling Transmitter Reset - HDLC Channel 3**
The transmitter of the signaling controller is reset. XFIFO3 is cleared of any data and an abort sequence (seven 1s) followed by interframe time fill is transmitted. In response to SRES3 an XPR3 interrupt is generated.
This command can be used by the CPU to abort a frame currently in transmission.

Common Configuration Register 3 (Read/Write)

Value after reset: 00_H

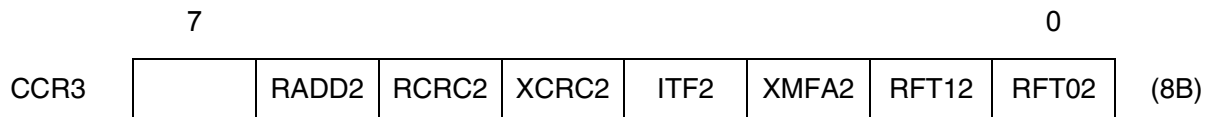

- RADD2 Receive Address Pushed to RFIFO2**
If this bit is set, the received HDLC channel 2 address information (1 or 2 bytes, depending on the address mode selected via MODE2.MDS02) is pushed to RFIFO2. This function is applicable in non-auto mode and transparent mode 1.

RCRC2 Receive CRC ON/OFF - HDLC Channel 2

Only applicable in non-auto mode.

If this bit is set, the received CRC checksum is written to RFIFO2 (CRC-ITU-T: 2 bytes). The checksum, consisting of the 2 last bytes in the received frame, is followed in the RFIFO2 by the status information byte (contents of register RSIS2). The received CRC checksum will additionally be checked for correctness. If non-auto mode is selected, the limits for "valid frame" check are modified.

XCRC2 Transmit CRC ON/OFF - HDLC Channel 2

If this bit is set, the CRC checksum will not be generated internally. It has to be written as the last two bytes in the transmit FIFO (XFIFO2). The transmitted frame is closed automatically with a closing flag.

ITF2 Interframe Time Fill - HDLC Channel 2

Determines the idle (= no data to be sent) state of the transmit data coming from the signaling controller.

- 0 = Continuous logical "1" is output
- 1 = Continuous flag sequences are output ("01111110" bit patterns)

XMFA2 Transmit Multiframe Aligned - HDLC Channel 2

Determines the synchronization between the framer and the corresponding signaling controller.

- 0 = The contents of the XFIFO2 is transmitted without multiframe alignment.
- 1 = The contents of the XFIFO2 is transmitted multiframe aligned.

RFT12, RFT02 RFIFO2 Threshold Level - HDLC Channel 2

The size of the accessible part of RFIFO2 can be determined by programming these bits. The number of valid bytes after an RPF interrupt is given in the following table:

RFT12	RFT02	Size of Accessible Part of RFIFO2
0	0	32 bytes (default value)
0	1	16 bytes
1	0	4 bytes
1	1	2 bytes

The value of RFT(1:0)2 can be changed dynamically if reception is not running or after the current data block has been read, but before the command CMDR3.RMC2 is issued (interrupt controlled data transfer).

Common Configuration Register 4 (Read/Write)

Value after reset: 00_H

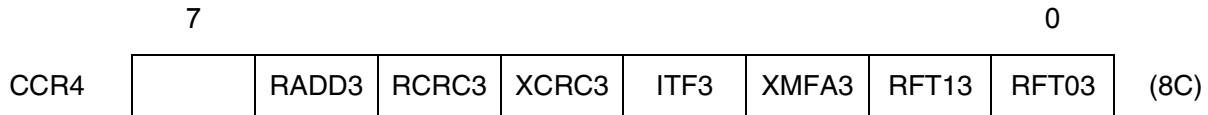

- RADD3 Receive Address Pushed to RFIFO3**

If this bit is set, the received HDLC channel 3 address information (1 or 2 bytes, depending on the address mode selected via MODE3.MDS03) is pushed to RFIFO3. This function is applicable in non-auto mode and transparent mode 1.
- RCRC3 Receive CRC ON/OFF - HDLC Channel 3**

Only applicable in non-auto mode.

If this bit is set, the received CRC checksum is written to RFIFO3 (CRC-ITU-T: 2 bytes). The checksum, consisting of the 2 last bytes in the received frame, is followed in the RFIFO3 by the status information byte (contents of register RSIS3). The received CRC checksum will additionally be checked for correctness. If non-auto mode is selected, the limits for "Valid Frame" check are modified.
- XCRC3 Transmit CRC ON/OFF - HDLC Channel 3**

If this bit is set, the CRC checksum will not be generated internally. It has to be written as the last two bytes in the transmit FIFO (XFIFO3). The transmitted frame is closed automatically with a closing flag.
- ITF3 Interframe Time Fill - HDLC Channel 3**

Determines the idle (= no data to be sent) state of the transmit data coming from the signaling controller.

0 = Continuous logical "1" is output

1 = Continuous flag sequences are output ("01111110" bit patterns)
- XMFA3 Transmit Multiframe Aligned - HDLC Channel 3**

Determines the synchronization between the framer and the corresponding signaling controller.

0 = The contents of the XFIFO3 is transmitted without multiframe alignment.

1 = The contents of the XFIFO3 is transmitted multiframe aligned.

RFT13, RFT03 RFIFO3 Threshold Level - HDLC Channel 3

The size of the accessible part of RFIFO3 can be determined by programming these bits. The number of valid bytes after an RPF interrupt is given in the following table:

RFT13	RFT03	Size of Accessible Part of RFIFO3
0	0	32 bytes (default value)
0	1	16 bytes
1	0	4 bytes
1	1	2 bytes

The value of RFT13/03 can be changed dynamically if reception is not running or after the current data block has been read, but before the command CMDR4.RMC3 is issued (interrupt controlled data transfer).

Common Configuration Register 5 (Read/Write)

Value after reset: 00_H

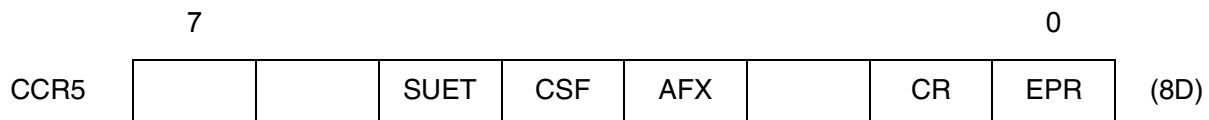

Note: SUET, CSF and AFX are only valid, if SS7 mode is selected.
CR and EPR are only valid, if PPR mode is selected.

SUET Signaling Unit Error Threshold - HDLC Channel 1

Defines the number of signaling units received in error that will cause an error rate high indication (ISR1.SUEX).

- 0 = Threshold 64 errored signaling units
- 1 = Threshold 32 errored signaling units

CSF Compare Status Field - HDLC Channel 1

If the status fields of consecutive LSSUs are equal, only the first is stored and every following is ignored.

- 0 = Compare disabled.
- 1 = Compare enabled.

- AFX Automatic FISU Transmission - HDLC Channel 1**
After the contents of the transmit FIFO (XFIFO) has been transmitted completely, FISUs are transmitted automatically. These FISUs contain the FSN and BSO of the last transmitted signaling unit (provided in XFIFO).
0 = Automatic FISU transmission disabled.
1 = Automatic FISU transmission enabled.
- CR Command Response - HDLC Channel 1**
Reflects the status of the CR bit in the SAPI octet transmitted during Periodical Performance Report (PPR), if CCR5.EPR = 1.
0 = CR bit = 0
1 = CR bit = 1
- EPR Enable Periodical Performance Report (PPR) - HDLC Channel 1**
If the periodical performance report is to be used, an HDLC format must be selected by MODE.MDS(2:0).
0 = PPR disabled.
1 = PPR enabled.

Mode Register 2 (Read/Write)

Value after reset: 00_H

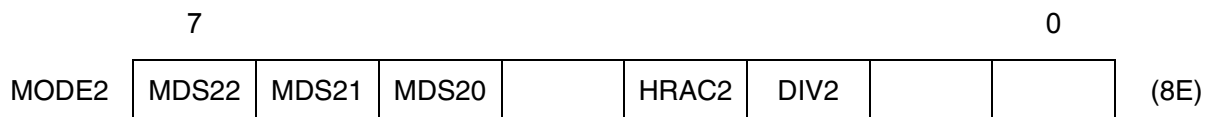

- MDS2(2:0) Mode Select - HDLC Channel 2**
The operating mode of the HDLC controller is selected.
000 =Reserved
001 =Reserved
010 =One-byte address comparison mode (RAL1, 2)
011 =Two-byte address comparison mode (RAH1, 2 and RAL1, 2)
100 =No address comparison
101 =One-byte address comparison mode (RAH1, 2)
110 =Reserved
111 =No HDLC framing mode 1

HRAC2 Receiver Active - HDLC Channel 2
Switches the HDLC receiver to operational or inoperational state.
0 = Receiver inactive
1 = Receiver active

DIV2 Data Inversion - HDLC Channel 2
Setting this bit will invert the internal generated HDLC data stream.
0 = Normal operation, HDLC data stream not inverted
1 = HDLC data stream inverted

Mode Register 3 (Read/Write)

Value after reset: 00_H

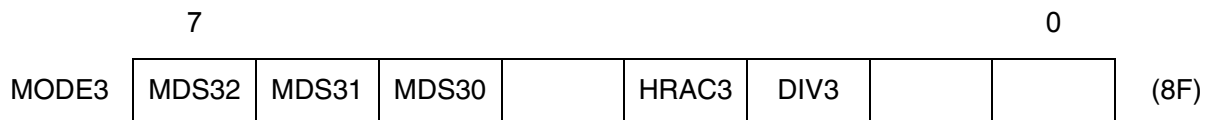

MDS3(2:0) Mode Select - HDLC Channel 3
The operating mode of the HDLC controller is selected.
000 =Reserved
001 =Reserved
010 =One-byte address comparison mode (RAL1, 2)
011 =Two-byte address comparison mode (RAH1, 2 and RAL1, 2)
100 =No address comparison
101 =One-byte address comparison mode (RAH1, 2)
110 =Reserved
111 =No HDLC framing mode 1

HRAC3 Receiver Active - HDLC Channel 3
Switches the HDLC receiver to operational or inoperational state.
0 = Receiver inactive
1 = Receiver active

DIV3 Data Inversion - HDLC Channel 3

Setting this bit will invert the internal generated HDLC data stream.

0 = Normal operation, HDLC data stream not inverted

1 = HDLC data stream inverted

Global Clock Mode Register 1 (Read/Write)

Value after reset: 00_H

	7							0	
GCM1	PHD_E1 7	PHD_E1 6	PHD_E1 5	PHD_E1 4	PHD_E1 3	PHD_E1 2	PHD_E1 1	PHD_E1 0	(92)

PHD_E1(7:0) Frequency Adjust for E1

For details see calculation formulas below.

Global Clock Mode Register 2 (Read/Write)

Value after reset: 00_H

	7						0		
GCM2	DVM_E1 2	DVM_E1 1	DVM_E1 0	VFREQ_ EN	PHD_E1 11	PHD_E1 10	PHD_E1 9	PHD_E1 8	(93)

PHD_E1(11:8) Frequency Adjust for E1

For details see calculation formulas below.

VFREQ_EN Variable Frequency Enable

0 = Fixed clock frequency of 2.048 (E1) or 1.544 MHz (T1/J1)

1 = Variable master clock frequency

DVM_E1(2:0) Divider Mode for E1

- 000 = Not valid
- 001 = Divide by DIV_E1 = 3
- 010 = Divide by DIV_E1 = 4 1/6
- 011 = Divide by DIV_E1 = 4
- 100 = Divide by DIV_E1 = 5.5
- 101 = Divide by DIV_E1 = 5 1/3
- 110 = Divide by DIV_E1 = 5 2/3
- 111 = Not valid

Global Clock Mode Register 3 (Read/Write)

Value after reset: 00_H

	7							0	
GCM3	PHD_T1	PHD_T1	PHD_T1	PHD_T1	PHD_T1	PHD_T1	PHD_T1	PHD_T1	(94)
	7	6	5	4	3	2	1	0	

PHD_T1(7:0) Frequency Adjust for T1

For details see calculation formulas below.

Global Clock Mode Register 4 (Read/Write)

Value after reset: 00_H

	7						0		
GCM4	DVM_T1 2	DVM_T1 1	DVM_T1 0	0	PHD_T1 11	PHD_T1 10	PHD_T1 9	PHD_T1 8	(95)

PHD_T1(11:8) Frequency Adjust for T1

For details see calculation formulas below.

DVM_T1(2:0) Divider Mode for T1

- 000 = Not valid
- 001 = Divide by DIV_T1 = 3
- 010 = Divide by DIV_T1 = 4 1/6
- 011 = Divide by DIV_T1 = 4
- 100 = Divide by DIV_T1 = 5.5
- 101 = Divide by DIV_T1 = 5 1/3
- 110 = Divide by DIV_T1 = 5 2/3
- 111 = Not valid

GCM4.4 reserved

Must be cleared.

Global Clock Mode Register 5 (Read/Write)

Value after reset: 00_H

	7							0	
GCM5	MCLK_ LOW			PLL_M 4	PLL_M 3	PLL_M 2	PLL_M 1	PLL_M 0	(96)

MCLK_LOW Master Clock Range Low

0 = Master clock frequency divided by (PLL_M+1) is greater than or equal 1.5 MHz

1 = Master clock frequency divided by (PLL_M+1) is less than 1.5 MHz

PLL_M(0:4) PLL Dividing Factor M

For details see calculation formulas below.

Note: Write operations to GCM5 initiate a PLL reset (see below).

Global Clock Mode Register 6 (Read/Write)

Value after reset: 00_H

	7							0	
GCM6				PLL_N 4	PLL_N 3	PLL_N 2	PLL_N 1	PLL_N 0	(97)

PLL_N(4:0) PLL Dividing Factor N

For details see calculation formulas below.

Note: Write operations to GCM6 initiate a PLL reset (see below).

Flexible Clock Mode Settings

If flexible master clock mode is used (VFREQ_EN = 1), the according register settings can be calculated as follows (a windows-based program for automatic calculation is available, see [Chapter 13.3](#) on [page 481](#)). For some of the standard frequencies see the table below.

1. PLL_M and PLL_N must fulfill the equations:

a. $1.5 \text{ MHz} \leq f_{\text{MCLK}} / (\text{PLL_M}+1) \leq 2.048 \text{ MHz}$

b. If (a.) is not possible, set MCLK_LOW and fulfill
 $1.02 \text{ MHz} \leq f_{\text{MCLK}} / (\text{PLL_M}+1) \leq 1.5 \text{ MHz}$

c. $65 \text{ MHz} \leq f_{\text{MCLK}} \times (2 \times \text{PLL_N}+2) / (\text{PLL_M}+1) \leq 69.7 \text{ MHz}$
 (as high as possible within this range)

2. Selection of dividing mode to best fulfill:

$$f_{\text{outE1}} = (f_{\text{MCLK}} \times (2 \times \text{PLL_N}+2) / (\text{PLL_M}+1)) / \text{DIV_E1} \text{ (target E1: 16.384 MHz)}$$

$$f_{\text{outT1}} = (f_{\text{MCLK}} \times (2 \times \text{PLL_N}+2) / (\text{PLL_M}+1)) / \text{DIV_T1} \text{ (target T1: 12.352 MHz)}$$

Though the target frequency might not be met directly, the dividing mode has to be selected to reach a frequency, which is as near as possible to the target frequency.

3. Calculation of correction value (frequency mismatch correction)

$$\text{PHD_E1} = 6 \times 4096 \times [\text{DIV_E1} - (2 \times \text{PLL_N}+2) / (\text{PLL_M}+1) \times (f_{\text{MCLK}} / 16.384 \text{ MHz})]$$

$$\text{PHD_T1} = 6 \times 4096 \times [\text{DIV_T1} - (2 \times \text{PLL_N}+2) / (\text{PLL_M}+1) \times (f_{\text{MCLK}} / 12.352 \text{ MHz})]$$

The result of these equations will be in the range of -2048 to +2047. Negative values are represented in 2s-complement format (e.g. $-2000_{\text{D}} = 830_{\text{H}}$; $+2000_{\text{D}} = 7D0_{\text{H}}$).

Table 66 Clock Mode Register Settings for E1 or T1/J1

f_{MCLK} [MHz]	GCM1	GCM2	GCM3	GCM4	GCM5	GCM6
1.544	F0 _H	51 _H	00 _H	80 _H	00 _H	15 _H
2.048	00 _H	58 _H	D2 _H	C2 _H	00 _H	10 _H
8.192	00 _H	58 _H	D2 _H	C2 _H	03 _H	10 _H
10.000	90 _H	51 _H	81 _H	8F _H	04 _H	10 _H
12.352	F0 _H	51 _H	00 _H	80 _H	07 _H	15 _H

Transmit FIFO 2 (Write)

Value after reset: 00_H

	7		0		
XFIFO2	XF7		XF0		(9C)
XFIFO2	XF15		XF8		(9D)

XF(15:0) Transmit FIFO - HDLC Channel 2
The function is equivalent to XFIFO.

Transmit FIFO 3 (Write)

Value after reset: 00_H

	7		0		
XFIFO3	XF7		XF0		(9E)
XFIFO3	XF15		XF8		(9F)

XF(15:0) Transmit FIFO - HDLC Channel 3
The function is equivalent to XFIFO.

Time Slot Even/Odd Select (Read/Write)

Value after reset: 00_H

	7		0						
TSEO			EO31	EO30	EO21	EO20	EO11	EO10	(A0)

HDLC protocol data can be sent in even, odd or both frames of a multiframe. Even frames are frame number 2, 4, and so on, odd frames are frame number 1, 3, and so on. The selection refers to receive and transmit direction as well. Each multiframe starts with an odd frame and ends with an even frame. By default all frames are used for HDLC reception and transmission.

Note: The different HDLC channels have to be configured to use different time slots, bit positions or frames.

EO1(1:0) Even/Odd frame selection - HDLC Channel 1
Channel 1 HDLC protocol data can be sent in even, odd or both frames of a multiframe.
00 = Even and odd frames
01 = Odd frames only
10 = Even frames only
11 = Undefined

EO2(1:0) Even/Odd frame selection - HDLC Channel 2
Channel 2 HDLC protocol data can be sent in even, odd or both frames of a multiframe.
00 = Even and odd frames
01 = Odd frames only
10 = Even frames only
11 = Undefined

EO3(1:0) Even/Odd frame selection - HDLC Channel 3
Channel 3 HDLC protocol data can be sent in even, odd or both frames of a multiframe.
00 = Even and odd frames
01 = Odd frames only
10 = Even frames only
11 = Undefined

Time Slot Bit Select 1 (Read/Write)

Value after reset: FF_H

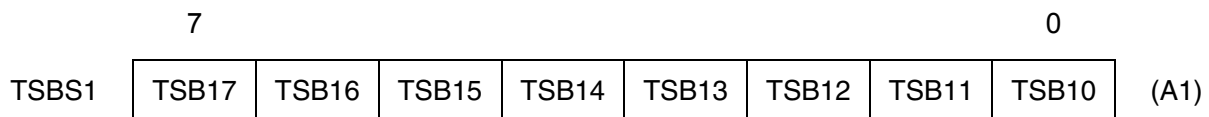

TSB1(7:0) = Time Slot Bit Selection - HDLC Channel 1
Only bits selected by this register are used for HDLC channel 1 in selected time slots. Time slot selection is done by setting the appropriate bits in registers TTR(4:1) and RTR(4:1) independently for receive and transmit direction. Bit selection is common to receive and transmit direction. By default all bit positions within the selected time slot(s) are enabled.
TSB1x = 0 to bit position x in selected time slot(s) is not used for HDLC channel 1 reception and transmission.

TSB1x = 1 to bit position x in selected time slot(s) is used for HDLC channel 1 reception and transmission.

Time Slot Bit Select 2 (Read/Write)

Value after reset: FF_H

	7							0	
TSBS2	TSB27	TSB26	TSB25	TSB24	TSB23	TSB22	TSB21	TSB20	(A2)

TSB2(7:0)

Time Slot Bit Selection - HDLC Channel 2

Only bits selected by this register are used for HDLC channel 2 in selected time slots. Time slot selection is done by setting the appropriate bits in register TSS2. Bit selection is common to receive and transmit direction. By default all bit positions within the selected time slot are enabled.

TSB2x=0 to bit position x in selected time slot(s) is not used for HDLC channel 2 reception and transmission.

TSB2x=1 to bit position x in selected time slot(s) is used for HDLC channel 2 reception and transmission.

Time Slot Bit Select 3 (Read/Write)

Value after reset: FF_H

	7							0	
TSBS3	TSB37	TSB36	TSB35	TSB34	TSB33	TSB32	TSB31	TSB30	(A3)

TSB3(7:0)

Time Slot Bit Selection - HDLC Channel 3

Only bits selected by this register are used for HDLC channel 3 in selected time slots. Time slot selection is done by setting the appropriate bits in register TSS3. Bit selection is common to receive and transmit direction. By default all bit positions within the selected time slot are enabled.

TSB3x=0 to bit position x in selected time slot(s) is not used for HDLC channel 3 reception and transmission.

TSB3x=1 to bit position x in selected time slot(s) is used for HDLC channel 3 reception and transmission.

Time Slot Select 2 (Read/Write)

Value after reset: 00_H

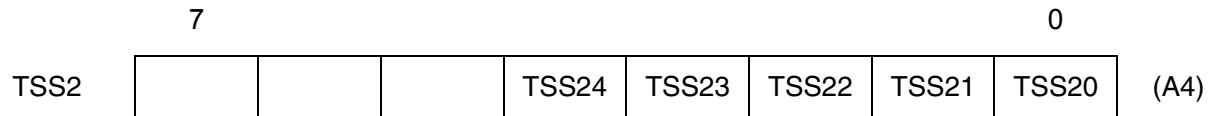

TSS2(4:0)

Time Slot Selection Code - HDLC Channel 2

Defines the time slot used by HDLC channel 2.

00000 =No time slot selected

00001 =Time slot 1

...

11111 =Time slot 31

Note: Different HDLC channels must use different time slots.

Time Slot Select 3 (Read/Write)

Value after reset: 00_H

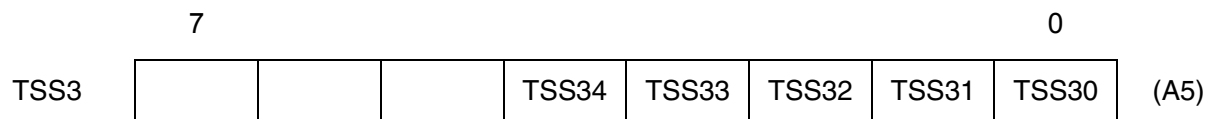

TSB3(4:0)

Time Slot Selection Code - HDLC Channel 3

Defines the time slot used by HDLC channel 3.

00000 =No time slot selected

00001 =Time slot 1

...

11111 =Time slot 31

Note: Different HDLC channels must use different time slots.

Test Pattern Control Register 0 (Read/Write)

Value after reset: 00_H



FRA

Framed/Unframed Selection

- 0 = PRBS is generated/monitored unframed.
Framing information is overwritten by the generator.
- 1 = PRBS is generated/monitored framed.
Time slot 0 is not overwritten by the generator and not observed by the monitor.

10.3 T1/J1 Status Register Addresses
Table 67 T1/J1 Status Register Address Arrangement

Address	Register	Type	Comment	Page
00	RFIFO	R	Receive FIFO	409
01	RFIFO	R	Receive FIFO	409
49	RBD	R	Receive Buffer Delay	409
4A	VSTR	R	Version Status Register	410
4B	RES	R	Receive Equalizer Status	410
4C	FRS0	R	Framer Receive Status 0	411
4D	FRS1	R	Framer Receive Status 1	413
4E	FRS2	R	Framer Receive Status 2	415
50	FECL	R	Framing Error Counter Low	416
51	FECH	R	Framing Error Counter High	416
52	CVCL	R	Code Violation Counter Low	417
53	CVCH	R	Code Violation Counter High	417
54	CECL	R	CRC Error Counter Low	418
55	CECH	R	CRC Error Counter High	418
56	EBCL	R	Errored Block Counter Low	419
57	EBCH	R	Errored Block Counter High	419
58	BECL	R	Bit Error Counter Low	420
59	BECH	R	Bit Error Counter High	420
5A	COEC	R	COFA Event Counter	421
5C	RDL1	R	Receive DL-Bit Register 1	422
5D	RDL2	R	Receive DL-Bit Register 2	422
5E	RDL3	R	Receive DL-Bit Register 3	423
62	RSP1	R	Receive Signaling Pointer 1	423
63	RSP2	R	Receive Signaling Pointer 2	423
64	SIS	R	Signaling Status Register	424
65	RSIS	R	Receive Signaling Status Register	425
66	RBCL	R	Receive Byte Control Low	427
67	RBCH	R	Receive Byte Control High	427
68	ISR0	R	Interrupt Status Register 0	428

T1/J1 Registers
Table 67 T1/J1 Status Register Address Arrangement (cont'd)

Address	Register	Type	Comment	Page
69	ISR1	R	Interrupt Status Register 1	430
6A	ISR2	R	Interrupt Status Register 2	431
6B	ISR3	R	Interrupt Status Register 3	433
6C	ISR4	R	Interrupt Status Register 4	434
6D	ISR5	R	Interrupt Status Register 5	436
6E	GIS	R	Global Interrupt Status	437
70	RS1	R	Receive Signaling Register 1	438
71	RS2	R	Receive Signaling Register 2	438
72	RS3	R	Receive Signaling Register 3	438
73	RS4	R	Receive Signaling Register 4	438
74	RS5	R	Receive Signaling Register 5	438
75	RS6	R	Receive Signaling Register 6	438
76	RS7	R	Receive Signaling Register 7	438
77	RS8	R	Receive Signaling Register 8	438
78	RS9	R	Receive Signaling Register 9	438
79	RS10	R	Receive Signaling Register 10	438
7A	RS11	R	Receive Signaling Register 11	438
7B	RS12	R	Receive Signaling Register 12	438
90	RBC2	R	Receive Byte Count Register 2	439
91	RBC3	R	Receive Byte Count Register 3	439
98	SIS2	R	Signaling Status Register 2	439
99	RSIS2	R	Receive Signaling Status Register 2	440
9A	SIS3	R	Signaling Status Register 3	442
9B	RSIS3	R	Receive Signaling Status Register 3	443
9C	RFIFO2	R	Receive FIFO 2	445
9D	RFIFO2	R	Receive FIFO 2	445
9E	RFIFO3	R	Receive FIFO 3	445
9F	RFIFO3	R	Receive FIFO 3	445
EC	WID	R	Identification Register	445

10.4 Detailed Description of T1/J1 Status Registers

Receive FIFO - HDLC Channel 1 (Read)

	7		0	
RFIFO	RF7		RF0	(00)
RFIFO	RF15		RF8	(01)

Reading data from RFIFO can be done in an 8-bit (byte) or 16-bit (word) access depending on the selected bus interface mode. The LSB is received first from the serial interface.

The size of the accessible part of RFIFO is determined by programming the bits CCR1.RFT(1:0) (RFIFO threshold level). It can be reduced from 32 bytes (reset value) down to 2 bytes (four values: 32, 16, 4, 2 bytes).

Data Transfer

Up to 32 bytes/16 words of received data can be read from the RFIFO following a RPF or a RME interrupt.

RPF Interrupt: A fixed number of bytes/words to be read (32, 16, 4, 2 bytes). The message is not yet complete.

RME Interrupt: The message is completely received. The number of valid bytes is determined by reading the RBCL, RBCH registers.

RFIFO is released by issuing the RMC (**R**ecieve **M**essage **C**omplete) command.

Receive Buffer Delay (Read)

	7		0						
RBD			RBD5	RBD4	RBD3	RBD2	RBD1	RBD0	(49)

RBD(5:0) Receive Elastic Buffer Delay

These bits inform the user about the current delay (in time slots) through the receive elastic buffer. The delay is updated every 386 or 193 bits (SIC1.RBS(1:0)). Before reading this register the user has to set bit DEC.DRBD in order to halt the current value of this register. After reading RBD updating of this register is enabled. Not valid if the receive buffer is bypassed.

000000 = Delay < 1 time slot

...

111111 = Delay > 63 time slots

Version Status Register (Read)

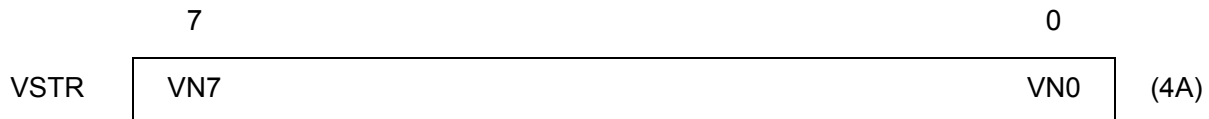

VN(7:0) Version Number of Chip

00_H =Version 1.2

Receive Equalizer Status (Read)

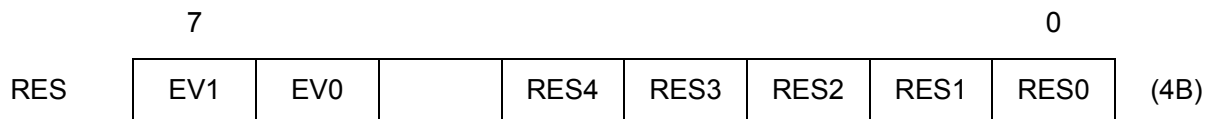

EV(1:0) Equalizer Status Valid

These bits informs the user about the current state of the receive equalization network. Only valid if LIM1.EQON is set.

00 = Equalizer status not valid, still adapting

01 = Equalizer status valid

10 = Equalizer status not valid

11 = Equalizer status valid but high noise floor

RES(4:0) Receive Equalizer Status

The current line attenuation status in steps of about 1.4 dB are displayed in these bits. Only valid if bits EV(1:0) = 01 and LIM1.EQON = 1.

Accuracy: ± 2 digits, based on temperature influence and noise amplitude variations.

00000 = Minimum attenuation: 0 dB

...

11001 = Maximum attenuation: -36 dB

Framer Receive Status Register 0 (Read)

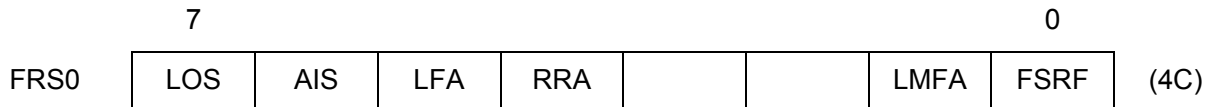

LOS Loss-of-Signal (Red Alarm)

Detection:

This bit is set when the incoming signal has “no transitions“ (analog interface) or logical zeros (digital interface) in a time interval of T consecutive pulses, where T is programmable by PCD register:

Total account of consecutive pulses: $16 < T < 4096$.

Analog interface: The receive signal level where “no transition” is declared is defined by the programmed value of LIM1.RIL(2:0).

Recovery:

Analog interface: The bit is reset in short-haul mode when the incoming signal has transitions with signal levels greater than the programmed receive input level (LIM1.RIL(2:0)) for at least M pulse periods defined by register PCR in the PCD time interval. In long-haul mode additionally bit RES.6 must be set for at least 250 μ s.

Digital interface: The bit is reset when the incoming data stream contains at least M ones defined by register PCR in the PCD time interval.

With the rising edge of this bit an interrupt status bit (ISR2.LOS) is set. For additionally recovery conditions refer also to register LIM2.LOS1. The bit is set during alarm simulation and reset if FRS2.ESC = 0, 3, 4, 6,7 and no alarm condition exists.

AIS Alarm Indication Signal (Blue Alarm)

This bit is set when the conditions defined by bit FMR4.AIS3 are detected. The flag stays active for at least one multiframe.

With the rising edge of this bit an interrupt status bit (ISR2.AIS) is set. It is reset with the beginning of the next following multiframe if no alarm condition is detected.

The bit is set during alarm simulation and reset if FRS2.ESC = 0, 3, 4, 7 and no alarm condition exists.

- LFA** **Loss of Frame Alignment**
- The flag is set if pulseframe synchronization has been lost. The conditions are specified by bit FMR4.SSC(1:0). Setting this bit causes an interrupt (ISR2.LFA).
- The flag is cleared when synchronization has been regained. Additionally interrupt status ISR2.FAR is set with clearing this bit.
- RRA** **Receive Remote Alarm (Yellow Alarm)**
- The flag is set after detecting remote alarm (yellow alarm). Conditions for setting/resetting are defined by bit RC0.RRAM.
- With the rising edge of this bit an interrupt status bit ISR2.RA is set.
- With the falling edge of this bit an interrupt status bit ISR2.RAR is set.
- The bit is set during alarm simulation and reset if FRS2.ESC = 0, 3, 4,5,7 and no alarm condition exists.
- LMFA** **Loss Of Multiframe Alignment**
- Set in F12 or F72 format when 2 out of 4 (or 5 or 6) multiframe alignment patterns are incorrect.
- Additionally the interrupt status bit ISR2.LMFA is set.
- Cleared after multiframe synchronization has been regained. With the falling edge of this bit an interrupt status bit ISR2.MFAR is generated.
- FSRF** **Frame Search Restart Flag**
- Toggles when no framing candidate (pulse framing or multiframe) is found and a new frame search is started.

Framer Receive Status Register 1 (Read)

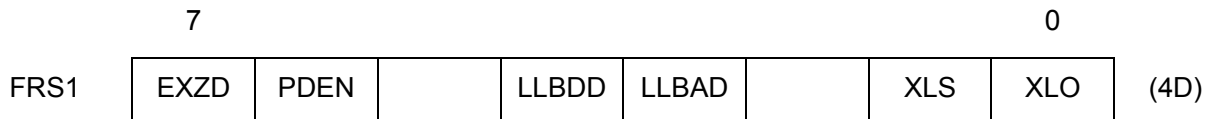

EXZD **Excessive Zeros Detected**

Significant only if excessive zeros detection is enabled (FMR2.EXZE = 1).

Set after detecting of more than 7 (B8ZS code) or more than 15 (AMI code) contiguous zeros in the received bit stream. This bit is cleared on read.

PDEN **Pulse-Density Violation Detected**

The pulse-density of the received data stream is below the requirement defined by ANSI T1. 403 or more than 14 consecutive zeros are detected. With the violation of the pulse-density this bit is set and remains active until the pulse-density requirement is fulfilled for 23 consecutive "1"-pulses.

Additionally an interrupt status ISR0.PDEN is generated with the rising edge of PDEN.

LLBDD **Line Loop-Back Deactivation Signal Detected**

This bit is set in case of the LLB deactivate signal is detected and then received over a period of more than 33,16 ms with a bit error rate less than 10^{-2} . The bit remains set as long as the bit error rate does not exceed 10^{-2} .

If framing is aligned, the first bit position of any frame is not taken into account for the error rate calculation.

Any change of this bit causes an LLBSC interrupt.

LLBAD **Line Loop-Back Activation Signal Detected/PRBS Status**

Depending on bit LCR1.EPRM the source of this status bit changed.

LCR1.EPRM = 0: This bit is set in case of the LLB activate signal is detected and then received over a period of more than 33,16 ms with a bit error rate less than 10^{-2} . The bit remains set as long as the bit error rate does not exceed 10^{-2} .

If framing is aligned, the first bit position of any frame is not taken into account for the error rate calculation.

Any change of this bit causes an LLBSC interrupt.

PRBS Status

LCR1.EPRM = 1: The current status of the PRBS synchronizer is indicated in this bit. It is set high if the synchronous state is reached even in the presence of a bit error rate of up to 10^{-3} . A data stream containing all zeros or all ones with/without framing bits is also a valid pseudo-random binary sequence.

XLS**Transmit Line Short**

Significant only if the ternary line interface is selected by LIM1.DRS = 0.

0 = Normal operation. No short is detected.

1 = The XL1 and XL2 are shortened for at least 3 pulses. As a reaction of the short the pins XL1 and XL2 are automatically forced into a high-impedance state if bit XPM2.DAXLT is reset. After 128 consecutive pulse periods the outputs XL1/2 are activated again and the internal transmit current limiter is checked. If a short between XL1/2 is still further active the outputs XL1/2 are in high-impedance state again. When the short disappears pins XL1/2 are activated automatically and this bit is reset. With any change of this bit an interrupt ISR1.XLSC is generated. In case of XPM2.XLT is set this bit is frozen.

XLO**Transmit Line Open**

0 = Normal operation

1 = This bit is set if at least 32 consecutive zeros were sent on pins XL1/XL2 or XDOP/XDON. This bit is reset with the first transmitted pulse. With the rising edge of this bit an interrupt ISR1.XLSC is set. In case of XPM2.XLT is set this bit is frozen.

Framer Receive Status Register 2 (Read)



ESC(2:0) Error Simulation Counter

This three-bit counter is incremented by setting bit FMR0.SIM. The state of the counter determines the function to be tested.

For complete checking of the alarm indications, eight simulation steps are necessary (FRS2.ESC = 0 after a complete simulation).

Table 68 Alarm Simulation States

Tested Alarms ESC(2:0) =	0	1	2	3	4	5	6	7
LFA			×				×	
LMFA			×				×	
RRA (bit2 = 0)		×						
RRA (S-bit frame 12)			×					
RRA (DL-pattern)							×	
LOS ¹⁾		×	×			×		
EBC ²⁾ (F12,F72)			×				(×)	
EBC ²⁾ (only ESF)		×	×			×	(×)	
AIS ¹⁾		×	×			×	×	
FEC ²⁾			×				(×)	
CVC		×	×			×		
CEC (only ESF)		×	×			×	×	
RSP		×						
RSN						×		
XSP		×						
XSN						×		
BEC ¹⁾		×	×			×		
COEC			×				×	

¹⁾ only active during FMR0.SIM = 1

²⁾ FEC is counting +2 while EBC is counting +1 if the framer is in synchronous state; if asynchronous in state 2 but synchronous in state 6, counters are incremented during state 6

T1/J1 Registers

Some of these alarm indications are simulated only if the FALC56 is configured in the appropriate mode. At simulation steps 0, 3, 4, and 7 pending status flags are reset automatically and clearing of the error counters and interrupt status registers ISR(5:0) should be done. Incrementing the simulation counter should not be done at time intervals shorter than 1.5 ms (F4, F12, F72) or 3 ms (ESF). Otherwise, reactions of initiated simulations might occur at later steps. Control bit FMR0.SIM has to be held stable at high or low level for at least one receive clock period before changing it again.

Framing Error Counter (Read)

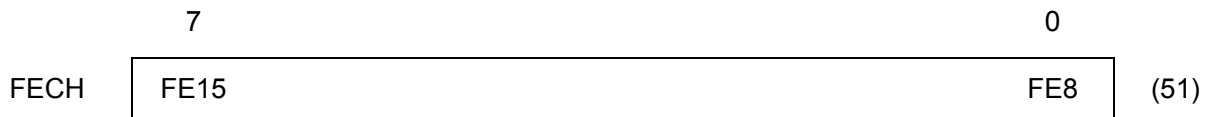
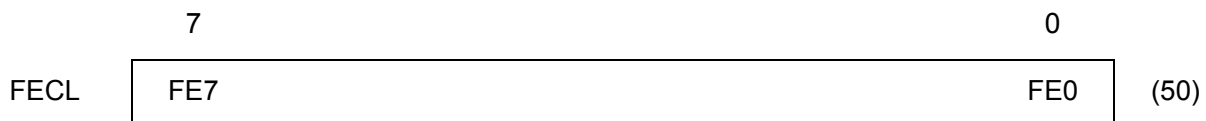

FE(15:0)

Framing Errors

This 16-bit counter is incremented when incorrect FT and FS-bits in F4, F12 and F72 format or incorrect FAS-bits in ESF format are received.

Framing errors are counted during synchronous state only (but even if multiframe synchronous state is not reached yet). The error counter does not roll over.

During alarm simulation, the counter is incremented twice.

Clearing and updating the counter is done according to bit FMR1.ECM.

If this bit is reset the error counter is permanently updated in the buffer. For correct read access of the error counter bit DEC.DFEC has to be set. With the rising edge of this bit updating the buffer is stopped and the error counter is reset. Bit DEC.DFEC is automatically reset with reading the error counter high byte.

If FMR1.ECM is set every second (interrupt ISR3.SEC) the error counter is latched and then automatically reset. The latched error counter state should be read within the next second.

Code Violation Counter (Read)

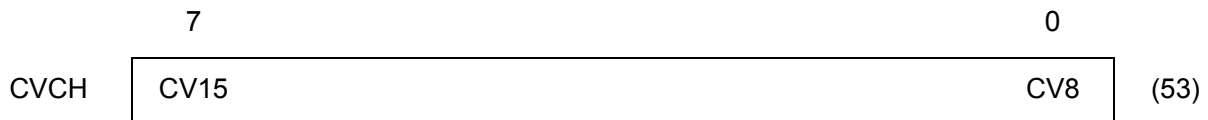
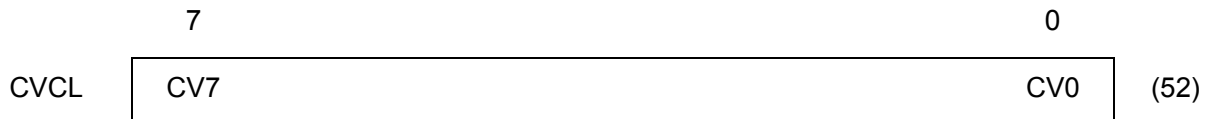

CV(15:0)

Code Violations

No function if NRZ or CMI code has been enabled.

If the B8ZS code (bit FMR0.RC(1:0) = 11) is selected, the 16-bit counter is incremented by detecting violations which are not due to zero substitution. If FMR2.EXZE is set, additionally excessive zero strings (more than 7 contiguous zeros) are detected and counted.

If simple AMI coding is enabled (FMR0.RC0/1 = 10) all bipolar violations are counted. If FMR2.EXZE is set, additionally excessive zero strings (more than 15 contiguous zeros) are detected and counted. The error counter does not roll over.

During alarm simulation, the counter is incremented continuously with every second received bit.

Clearing and updating the counter is done according to bit FMR1.ECM.

If this bit is reset the error counter is permanently updated in the buffer. For correct read access of the error counter bit DEC.DCVC has to be set. With the rising edge of this bit updating the buffer is stopped and the error counter is reset. Bit DEC.DCVC is automatically reset with reading the error counter high byte.

If FMR1.ECM is set every second (interrupt ISR3.SEC) the error counter is latched and then automatically reset. The latched error counter state should be read within the next second.

CRC Error Counter (Read)

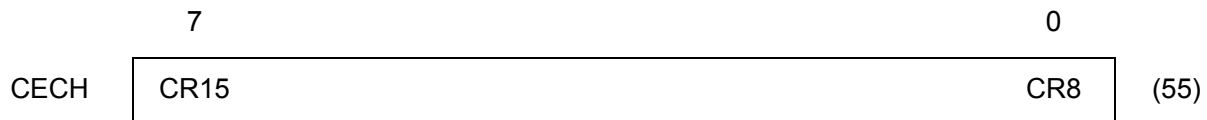
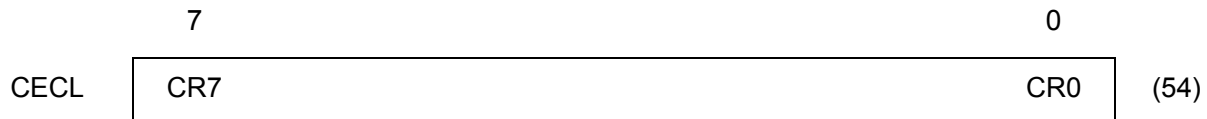

CR(15:0)

CRC Errors

No function if CRC6 procedure or ESF format are disabled.

In ESF mode, the 16-bit counter is incremented when a multiframe has been received with a CRC error. CRC errors are not counted during asynchronous state. The error counter does not roll over.

During alarm simulation, the counter is incremented once per multiframe.

Clearing and updating the counter is done according to bit FMR1.ECM.

If this bit is reset the error counter is permanently updated in the buffer. For correct read access of the error counter bit DEC.DCEC has to be set. With the rising edge of this bit updating the buffer is stopped and the error counter is reset. Bit DEC.DCEC is automatically reset with reading the error counter high byte.

If FMR1.ECM is set every second (interrupt ISR3.SEC) the error counter is latched and then automatically reset. The latched error counter state should be read within the next second.

Errored Block Counter (Read)

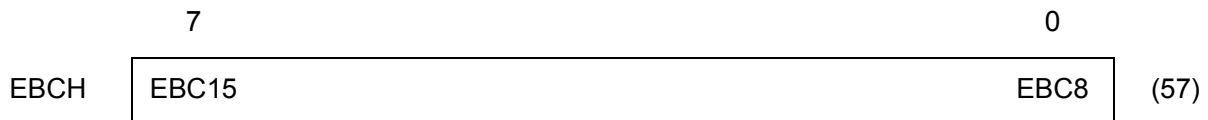
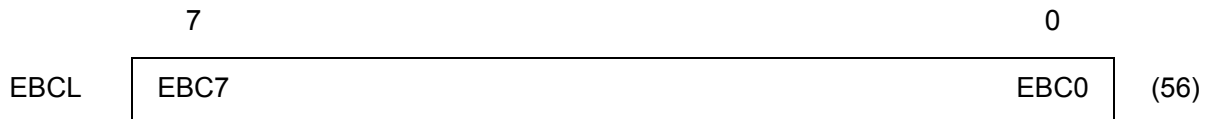

EBC(15:0) Errored Block Counter

In ESF format this 16-bit counter is incremented once per multiframe if a multiframe has been received with a CRC error or an errored frame alignment has been detected. CRC and framing errors are not counted during asynchronous state. The error counter does not roll over.

In F4/12/72 format an errored block contain 4/12 or 72 frames. Incrementing is done once per multiframe if framing errors has been detected.

During alarm simulation, the counter is incremented in ESF format once per multiframe and in F4/12/72 format only one time.

Clearing and updating the counter is done according to bit FMR1.ECM.

If this bit is reset the error counter is permanently updated in the buffer. For correct read access of the error counter bit DEC.DEBC has to be set. With the rising edge of this bit updating the buffer is stopped and the error counter is reset. Bit DEC.DEBC is automatically reset with reading the error counter high byte.

If FMR1.ECM is set every second (interrupt ISR3.SEC) the error counter is latched and then automatically reset. The latched error counter state should be read within the next second.

Bit Error Counter (Read)

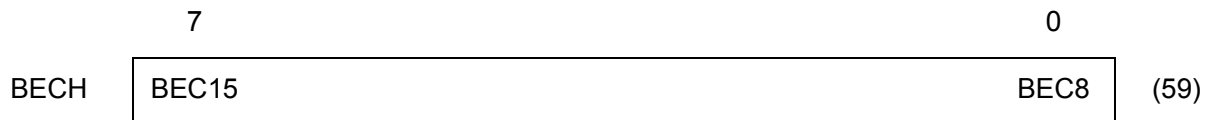
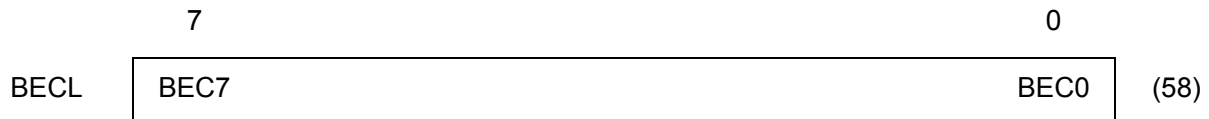

BEC(15:0)

Bit Error Counter

If the PRBS monitor is enabled by LCR1.EPRM = 1 this 16-bit counter is incremented with every received PRBS bit error in the PRBS synchronous state FRS1.LLBAD = 1. The error counter does not roll over.

During alarm simulation, the counter is incremented continuously with every second received bit.

Clearing and updating the counter is done according to bit FMR1.ECM.

If this bit is reset the error counter is permanently updated in the buffer. For correct read access of the PRBS bit error counter bit DEC.DBEC has to be set. With the rising edge of this bit updating the buffer is stopped and the error counter is reset. Bit DEC.DBEC is automatically reset with reading the error counter high byte.

If FMR1.ECM is set every second (interrupt ISR3.SEC) the error counter is latched and then automatically reset. The latched error counter state should be read within the next second.

COFA Event Counter (Read)

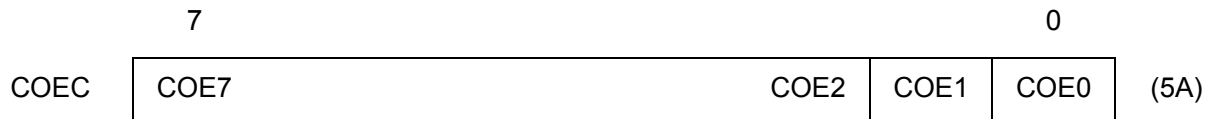

COE(7:2) Multiframe Counter

If GCR.ECMC = 1 this 6 bit counter increments with each multiframe period in the asynchronous state FRS0.LFA/LMFA = 1. The error counter does not roll over.

COE(1:0) Change of Frame Alignment Counter

If GCR.ECMC = 1 this 2 bit counter increments with each detected change of frame/multiframe alignment. The error counter does not roll over.

During alarm simulation, the counter is incremented once per multiframe.

Clearing and updating the counter is done according to bit FMR1.ECM.

If this bit is reset the error counter is permanently updated in the buffer. For correct read access of the event counter bit DEC.DCOEC has to be set. With the rising edge of this bit updating the buffer is stopped and the error counter is reset. Bit DEC.DCOEC is automatically reset with reading the error counter high byte on address 5B_H. Data read on 5B_H is not defined.

If FMR1.ECM is set every second (interrupt ISR3.SEC) the error counter is latched and then automatically reset. The latched error counter state should be read within the next second.

Receive DL-Bit Register 1 (Read)

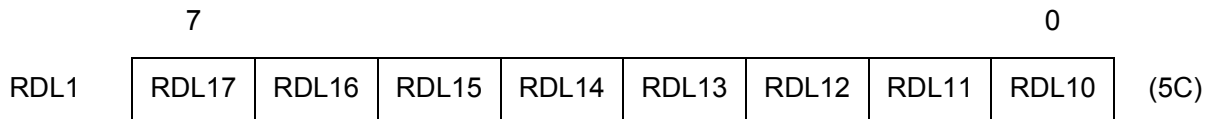

RDL1(7:0) Receive DL-Bit

Only valid if F12, F24 or F72 format is enabled.
 The received FS/DL-Bits are shifted into this register. RDL10 is received in frame 1 and RDL17 in frame 15, if F24 format is enabled. RDL10 is received in frame 26 and RDL17 in frame 40, if F72 format is enabled.
 In F12 format the FS-Bits of a complete multiframe is stored in this register. RDL10 is received in frame 2 and RDL15 in frame 12.
 This register is updated with every receive multiframe begin interrupt ISR0.RMB.

Receive DL-Bit Register 2 (Read)

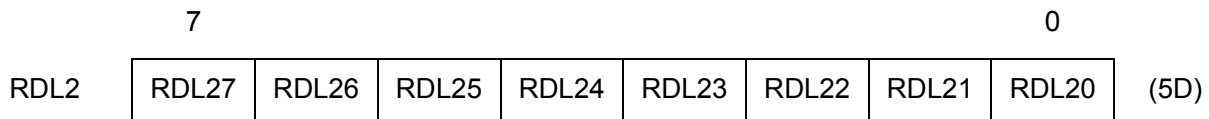

RDL2(7:0) Receive DL-Bit

Only valid if F24 or F72 format is enabled.
 The received DL-Bits are shifted into this register. RDL20 is received in frame 17 and RDL23 in frame 23, if F24 format is enabled. RDL20 is received in frame 42 and RDL27 in frame 56, if F72 format is enabled.
 This register is updated with every receive multiframe begin interrupt ISR0.RMB.

Receive DL-Bit Register 3 (Read)

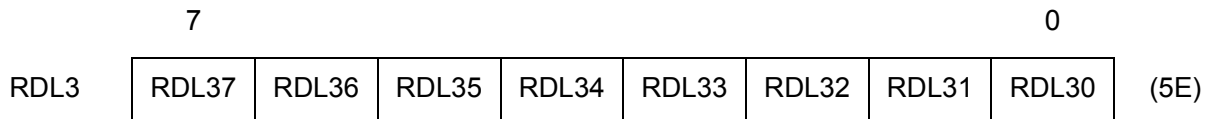

RDL3(7:0) Receive DL-Bit

Only valid if F72 format is enabled.

The received DL-Bits are shifted into this register. RDL30 is received in frame 58 and RDL37 in frame 72, if F72 format is enabled.

This register is updated with every receive multiframe begin interrupt ISR0.RMB.

Receive Signaling Pointer 1 (Read)

Value after reset: 00_H

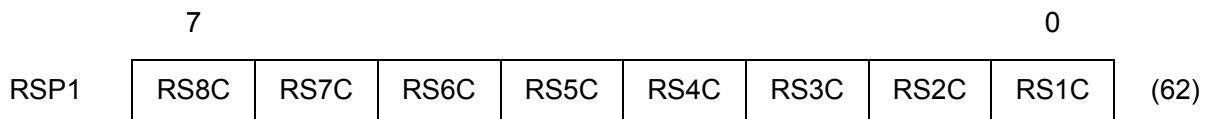

RS(8:1)C Receive Signaling Register RS(8:1) Changed

A one in each bit position indicates that the received signaling data in the corresponding RS(8:1) registers are updated. Bit RS1C is the pointer for register RS1, while RS8C points to RS8.

Receive Signaling Pointer 2 (Read)

Value after reset: 00_H

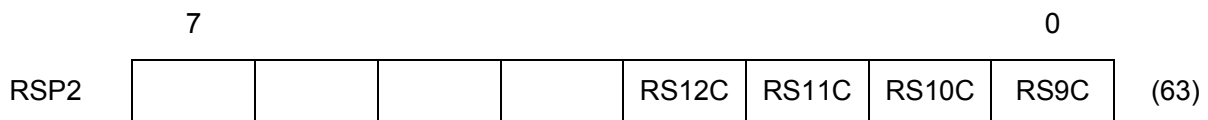

RS(12:0)C Receive Signaling Register RS(12:9) Changed

A one in each bit position indicates that the received signaling data in the corresponding RS(12:9) registers are updated. Bit RS9C is the pointer for register RS9, while RS12C points to RS12

RAB	Receive Message Aborted - HDLC Channel 1 This bit is set in SS7 mode, if the maximum number of octets (272+7) is exceeded. The received frame was aborted from the transmitting station. According to the HDLC protocol, this frame must be discarded by the receiver station.
HA1, HA0	High Byte Address Compare - HDLC Channel 1 Significant only if 2-byte address mode or SS7 mode has been selected. In operating modes which provide high byte address recognition, the FALC56 compares the high byte of a 2-byte address with the contents of two individually programmable registers (RAH1, RAH2) and the fixed values FE _H and FC _H (broadcast address). Depending on the result of this comparison, the following bit combinations are possible (SS7 support not active): 00 = RAH2 has been recognized 01 = Broadcast address has been recognized 10 = RAH1 has been recognized C/R = 0 (bit 1) 11 = RAH1 has been recognized C/R = 1 (bit 1) Note: If RAH1, RAH2 contain identical values, a match is indicated by "10" or "11". If Signaling System 7 support is activated (see MODE register), the bit functions are defined as follows: 00 = not valid 01 = Fill In signaling unit (FISU) detected 10 = Link status signaling unit (LSSU) detected 11 = Message signaling unit (MSU) detected
HFR	HDLC Frame Format - HDLC Channel 1 0 = A BOM frame was received. 1 = A HDLC frame was received. Note: Bits RSIS.(7:2) and RSIS.0 are not valid with a BOM frame. This means, if HFR = 0, all other bits of RSIS have to be ignored Not valid in SS7 mode. Bit HFR has to be ignored, if SS7 mode is selected.

LA Low Byte Address Compare - HDLC Channel 1

Significant in HDLC modes only.

The low byte address of a 2-byte address field, or the single address byte of a 1-byte address field is compared to two registers. (RAL1, RAL2).

0 = RAL2 has been recognized

1 = RAL1 has been recognized

Note: Not valid in SS7 mode. Bit LA has to be ignored, if SS7 mode is selected.

Receive Byte Count Low - HDLC Channel 1 (Read)

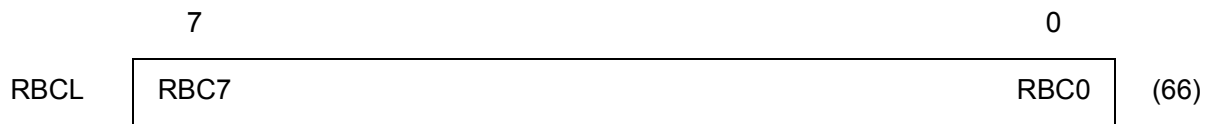

Together with RBCH, bits RBC(11:8), indicates the length of a received frame (1 to 4095 bytes). Bits RBC(4:0) indicate the number of valid bytes currently in RFIFO. These registers must be read by the CPU following a RME interrupt.

Received Byte Count High - HDLC Channel 1 (Read)

Value after reset: 000_{xxxxx}

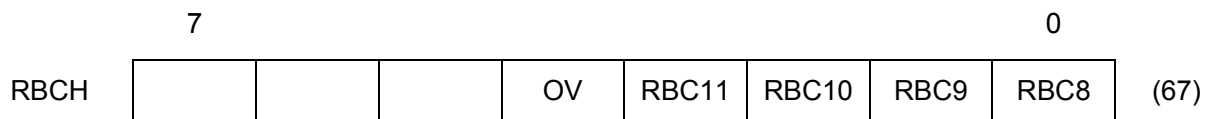

OV Counter Overflow - HDLC Channel 1

More than 4095 bytes received.

RBC(11:8) Receive Byte Count - HDLC Channel 1 (most significant bits)

Together with RBCL (bits RBC7...0) indicates the length of the received frame.

Interrupt Status Register 0 (Read)

Value after reset: 00_H

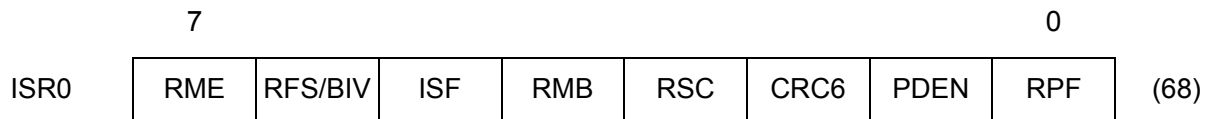

All bits are reset when ISR0 is read.

If bit GCR.VIS is set, interrupt statuses in ISR0 are flagged although they are masked by register IMR0. However, these masked interrupt statuses neither generate a signal on INT, nor are visible in register GIS.

RME Receive Message End - HDLC Channel 1

One complete message of length less than 32 bytes, or the last part of a frame at least 32 bytes long is stored in the receive FIFO, including the status byte.

The complete message length can be determined reading the RBCH, RBCL registers, the number of bytes currently stored in RFIFO is given by RBC(4:0). Additional information is available in the RSIS register.

RFS/BIV Receive Frame Start - HDLC Channel 1

This is an early receiver interrupt activated after the start of a valid frame has been detected, i.e. after an address match (in operation modes providing address recognition), or after the opening flag (transparent mode 0) is detected, delayed by two bytes. After a RFS interrupt, the contents of RAL1 and RSIS.3-1 are valid and can be read by the CPU.

BOM Frame Invalid - HDLC Channel 1

Only valid if CCR2.RBFE is set.

When the BOM receiver left the valid BOM status (detecting 7 out of 10 equal BOM frames) this interrupt is generated.

ISF Incorrect Sync Format - HDLC Channel 1

The FALC56 did not detect eight consecutive ones within 32 bits in BOM mode. Only valid if BOM receiver has been activated.

RMB Receive Multiframe Begin

This bit is set with the beginning of a received multiframe of the receive line timing.

RSC	Received Signaling Information Changed This interrupt bit is set during each multiframe in which signaling information on at least one channel changes its value from the previous multiframe. This interrupt only occurs in the synchronous state. The registers RS(12:1) should be read within the next 3 ms otherwise the contents is lost.
CRC6	Receive CRC6 Error 0 = No CRC6 error occurs. 1 = The CRC6 check of the last received multiframe failed.
PDEN	Pulse-Density Violation The pulse-density violation of the received data stream defined by ANSI T1. 403 is violated. More than 14 consecutive zeros or less than N ones in each and every time window of $8 \times (N+1)$ data bits ($N = 23$) are detected. If GCR.SCI is set high this interrupt status bit is activated with every change of state of FRS1.PDEN.
RPF	Receive Pool Full - HDLC Channel 1 32 bytes of a frame have arrived in the receive FIFO. The frame is not yet received completely.

Interrupt Status Register 1 (Read)

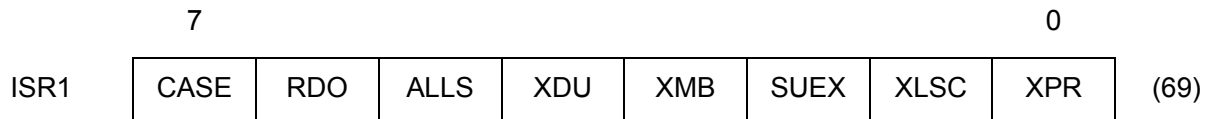

All bits are reset when ISR1 is read.

If bit GCR.VIS is set, interrupt statuses in ISR1 are flagged although they are masked by register IMR1. However, these masked interrupt statuses neither generate a signal on INT, nor are visible in register GIS.

CASE Transmit CAS Register Empty

In ESF format this bit is set with the beginning of a transmitted multiframe related to the internal transmitter timing. In F12 and F72 format this interrupt occurs every 24 frames to inform the user that new bit robbing data may be written to the XS(12:1) registers. This interrupt is generated only if the serial signaling access on the system highway is not enabled.

RDO Receive Data Overflow - HDLC Channel 1

This interrupt status indicates that the CPU did not respond fast enough to an RPF or RME interrupt and that data in RFIFO has been lost. Even when this interrupt status is generated, the frame continues to be received when space in the RFIFO is available again.

Note: Whereas the bit RSIS.RDO in the frame status byte indicates whether an overflow occurred when receiving the frame currently accessed in the RFIFO, the ISR1.RDO interrupt status is generated as soon as an overflow occurs and does not necessarily pertain to the frame currently accessed by the processor.

ALLS All Sent - HDLC Channel 1

This bit is set if the last bit of the current frame has been sent completely and XFIFO is empty. This bit is valid in HDLC mode only.

XDU Transmit Data Underrun - HDLC Channel 1

Transmitted frame was terminated with an abort sequence because no data was available for transmission in XFIFO and no XME was issued.

Note: Transmitter and XFIFO are reset and deactivated if this condition occurs. They are reactivated not before this interrupt status register has been read. Thus, XDU should not be masked by register IMR1.

- XMB** **Transmit Multiframe Begin**
This bit is set with the beginning of a transmitted multiframe related to the internal transmit line interface timing.
- SUEX** **Signaling Unit Error Threshold Exceeded - HDLC Channel 1**
Masks the indication by interrupt that the selected error threshold for SS7 signaling units has been exceeded.
0 = Signaling unit error count below selected threshold
1 = Signaling unit error count exceeded selected threshold
Note: SUEX is only valid, if SS7 mode is selected.
If SUEX is caused by an aborted/invalid frame, the interrupt will be issued regularly until a valid frame is received (e.g. a FISU).
- XLSC** **Transmit Line Status Change**
XLSC is set with the rising edge of the bit FRS1.XLO or with any change of bit FRS1.XLS.
The actual status of the transmit line monitor can be read from the FRS1.XLS and FRS1.XLO.
- XPR** **Transmit Pool Ready - HDLC Channel 1**
A data block of up to 32 bytes can be written to the transmit FIFO. XPR enables the fastest access to XFIFO. It has to be used for transmission of long frames, back-to-back frames or frames with shared flags.

Interrupt Status Register 2 (Read)

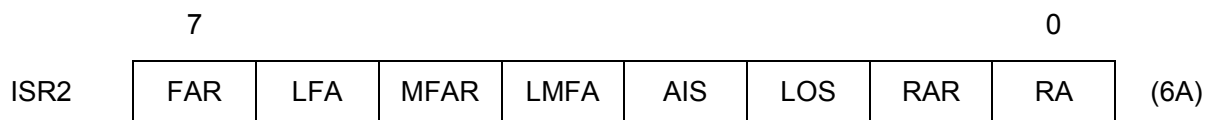

All bits are reset when ISR2 is read.
If bit GCR.VIS is set, interrupt statuses in ISR2 are flagged although they are masked by register IMR2. However, these masked interrupt statuses neither generate a signal on INT, nor are visible in register GIS.

- FAR** **Frame Alignment Recovery**
The framer has reached synchronization. Set with the falling edge of bit FRS0.LFA.
It is set also after alarm simulation is finished and the receiver is still synchronous.

LFA	Loss of Frame Alignment The framer has lost synchronization and bit FRS0.LFA is set. It is set during alarm simulation.
MFAR	Multiframe Alignment Recovery Set when the framer has reached multiframe alignment in F12 or F72 format. With the negative transition of bit FRS0.LMFA this bit is set. It is set during alarm simulation.
LMFA	Loss of Multiframe Alignment Set when the framer has lost the multiframe alignment in F12 or F72 format. With the positive transition of bit FRS0.LMFA this bit is set. It is set during alarm simulation.
AIS	Alarm Indication Signal (Blue Alarm) This bit is set when an alarm indication signal is detected and bit FRS0.AIS is set. If GCR.SCI is set high this interrupt status bit is activated with every change of state of FRS0.AIS. It is set during alarm simulation.
LOS	Loss-of-Signal (Red Alarm) This bit is set when a loss-of-signal alarm is detected in the received data stream and FRS0.LOS is set. If GCR.SCI is set high this interrupt status bit is activated with every change of state of FRS0.LOS. It is set during alarm simulation.
RAR	Remote Alarm Recovery Set if a remote alarm (yellow alarm) is cleared and bit FRS0.RRA is reset. It is set also after alarm simulation is finished and no remote alarm is detected.
RA	Remote Alarm A remote alarm (yellow alarm) is detected. Set with the rising edge of bit FRS0.RRA. It is set during alarm simulation.

Interrupt Status Register 3 (Read)

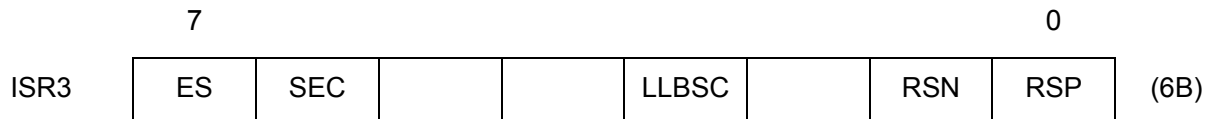

All bits are reset when ISR3 is read.

If bit GCR.VIS is set, interrupt statuses in ISR3 are flagged although they are masked by register IMR3. However, these masked interrupt statuses neither generate a signal on INT, nor are visible in register GIS.

ES Errored Second
This bit is set if at least one enabled interrupt source by ESM is set during the time interval of one second. Interrupt sources of ESM register:

- LFA = Loss of frame alignment detected
- FER = Framing error received
- CER = CRC error received
- AIS = Alarm indication signal (blue alarm)
- LOS = Loss-of-signal (red alarm)
- CVE = Code violation detected
- SLIP = Transmit slip or receive slip positive/negative detected

SEC Second Timer
The internal one-second timer has expired. The timer is derived from clock RCLK.

LLBSC Line Loop-Back Status Change/PRBS Status Change
Depending on bit LCR1.EPRM the source of this interrupt status changed:

LCR1.EPRM = 0: This bit is set, if the LLB activate signal or the LLB deactivate signal is detected over a period of 33,16 ms with a bit error rate less than 10⁻².

The LLBSC bit is also set, if the current detection status is left, i.e., if the bit error rate exceeds 10⁻².

The actual detection status can be read from the FRS1.LLBAD and FRS1.LLBDD, respectively.

PRBS Status Change
LCR1.EPRM = 1: With any change of state of the PRBS synchronizer this bit is set. The current status of the PRBS synchronizer is indicated in FRS1.LLBAD.

RSN Receive Slip Negative

The frequency of the receive route clock is greater than the frequency of the receive system interface working clock based on 1.544 MHz. A frame is skipped. It is set during alarm simulation.

RSP Receive Slip Positive

The frequency of the receive route clock is less than the frequency of the receive system interface working clock based on 1.544 MHz. A frame is repeated. It is set during alarm simulation.

Interrupt Status Register 4 (Read)

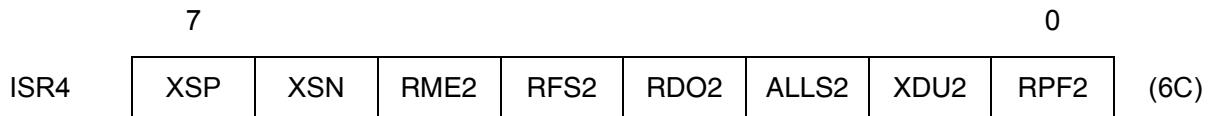

All bits are reset when ISR4 is read.

If bit GCR.VIS is set, interrupt statuses in ISR4 are flagged although they are masked by register IMR4. However, these masked interrupt statuses neither generate a signal on INT, nor are visible in register GIS.

XSP Transmit Slip Positive

The frequency of the transmit clock is less than the frequency of the transmit system interface working clock based on 1.544 MHz. A frame is repeated. After a slip has performed writing of register XC1 is not necessary.

XSN Transmit Slip Negative

The frequency of the transmit clock is greater than the frequency of the transmit system interface working clock based on 1.544 MHz. A frame is skipped. After a slip has performed writing of register XC1 is not necessary.

RME2 Receive Message End - HDLC Channel 2

One complete message of length less than 32 bytes, or the last part of a frame at least 32 bytes long is stored in the receive FIFO2, including the status byte.

The complete message length can be determined reading register RBC2, the number of bytes currently stored in RFIFO2 is given by RBC2(6:0). Additional information is available in register RSIS2.

- RFS2** **Receive Frame Start - HDLC Channel 2**
- This is an early receiver interrupt activated after the start of a valid frame has been detected, i.e. after an address match (in operation modes providing address recognition), or after the opening flag (transparent mode 0) is detected, delayed by two bytes. After an RFS2 interrupt, the contents of
- RAL1
 - RSIS2 bits 3 to 1
- are valid and can be read by the CPU.
- RDO2** **Receive Data Overflow - HDLC Channel 2**
- This interrupt status indicates that the CPU did not respond fast enough to an RPF2 or RME2 interrupt and that data in RFIFO2 has been lost. Even when this interrupt status is generated, the frame continues to be received when space in the RFIFO2 is available again.
- Note: Whereas the bit RSIS2.RDO2 in the frame status byte indicates whether an overflow occurred when receiving the frame currently accessed in the RFIFO2, the ISR4.RDO2 interrupt status is generated as soon as an overflow occurs and does not necessarily pertain to the frame currently accessed by the processor.
- ALLS2** **All Sent - HDLC Channel 2**
- This bit is set if the last bit of the current frame has been sent completely and XFIFO2 is empty. This bit is valid in HDLC mode only.
- XDU2** **Transmit Data Underrun - HDLC Channel 2**
- Transmitted frame was terminated with an abort sequence because no data was available for transmission in XFIFO2 and no XME2 was issued.
- Note: Transmitter and XFIFO2 are reset and deactivated if this condition occurs. They are reactivated not before this interrupt status register has been read. Thus, XDU2 should not be masked via register IMR4.
- RPF2** **Receive Pool Full - HDLC Channel 2**
- 32 bytes of a frame have arrived in the receive FIFO2. The frame is not yet completely received.

Receive Signaling Register (Read)

Value after reset: not defined

Table 69 Receive Signaling Registers (T1/J1)

	7							0	
RS1	A1	B1	C1/A2	D1/B2	A2/A3	B2/B3	C2/A4	D2/B4	(70)
RS2	A3/A5	B3/B5	C3/A6	D3/B6	A4/A7	B4/B7	C4/A8	D4/B8	(71)
RS3	A5/A9	B5/B9	C5/A10	D5/B10	A6/A11	B6/B11	C6/A12	D6/B12	(72)
RS4	A7/A13	B7/B13	C7/A14	D7/B14	A8/A15	B8/B15	C8/A16	D8/B16	(73)
RS5	A9/A17	B9/B17	C9/A18	D9/B18	A10/A19	B10/B19	C10/A20	D10/B20	(74)
RS6	A11/A21	B11/B21	C11/A22	D11/B22	A12/A23	B12/B23	C12/A24	D12/B24	(75)
RS7	A13/A1	B13/B1	C13/A2	D13/B2	A14/A3	B14/B3	C14/A4	D14/B4	(76)
RS8	A15/A5	B15/B5	C15/A6	D15/B6	A16/A7	B16/B7	C16/A8	D16/B8	(77)
RS9	A17/A9	B17/B9	C17/A10	D17/B10	A18/A11	B18/B11	C18/A12	D18/B12	(78)
RS10	A19/A13	B19/B13	C19/A14	D19/B14	A20/A15	B20/B15	C20/A16	D20/B16	(79)
RS11	A21/A17	B21/B17	C21/A18	D21/B18	A22/A19	B22/B19	C22/A20	D22/B20	(7A)
RS12	A23/A21	B23/B21	C23/A22	D23/B22	A24/A23	B24/B23	C24/A24	D24/B24	(7B)

Receive Signaling Register 1 to 12

Each register contains the received bit robbing information for 8 DS0 channels. The received robbed bit signaling information of a complete ESF multiframe is compared to the previously received one. In F12/72 frame format the received signaling information of every 24 frames is compared to the previously received 24 frames. If the contents changed a Receive Signaling Changed interrupt ISR0.RSC is generated and informs the user that a new multiframe has to be read within the next 3 ms. Received data is stored in RS(12:1) registers. The RS1.7 is received in channel 1 frame 1 and RS12.0 in channel 12 frame 24 (ESF).

If requests for reading the RS(12:1) registers are ignored, received data might get lost.

Additionally a receive signaling data change pointer indicates an update of register RS(12:1). Refer also to register RSP(2:1).

Access to RS(12:1) registers is only valid if the serial receive signaling access on the system highway is disabled.

Receive Byte Count Register 2 (Read)

Value after reset: 00_H

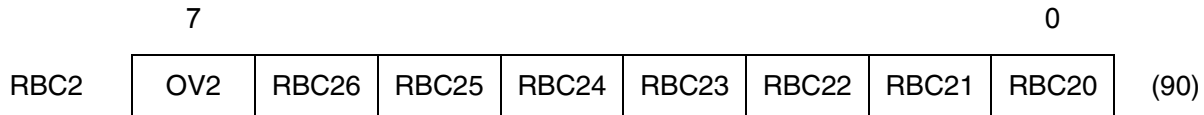

OV2 Counter Overflow - HDLC Channel 2

0 = Less than or equal to 128 bytes received

1 = More than 128 bytes received

RBC2(6:0) Receive Byte Count - HDLC Channel 2

Indicates the length of a received frame.

Receive Byte Count Register 3 (Read)

Value after reset: 00_H

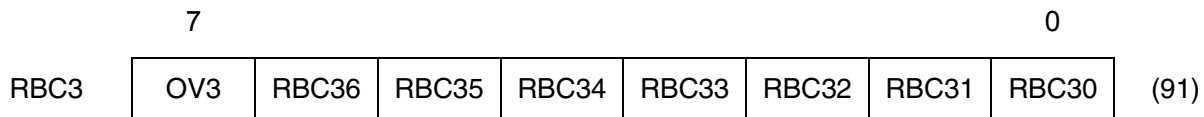

OV3 Counter Overflow - HDLC Channel 3

0 = Less than or equal to 128 bytes received

1 = More than 128 bytes received

RBC3(6:0) Receive Byte Count - HDLC Channel 3

Indicates the length of a received frame.

Signaling Status Register 2 (Read)

Value after reset: 00_H

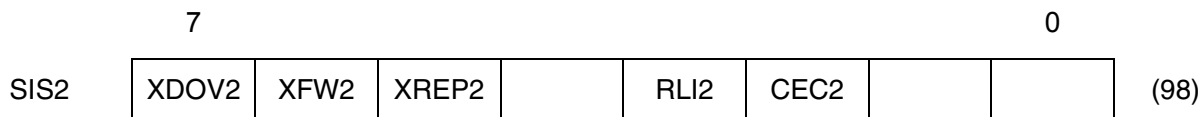

XDOV2 Transmit Data Overflow - HDLC Channel 2

More than 32 bytes have been written to the XFIFO2.

This bit is reset

- by a transmitter reset command XRES or
- when all bytes in the accessible half of the XFIFO2 have been moved in the inaccessible half.

- XFW2** **Transmit FIFO Write Enable - HDLC Channel 2**
Data can be written to the XFIFO2.
- XREP2** **Transmission Repeat - HDLC Channel 2**
Status indication of CMDR2.XREP2.
- RLI2** **Receive Line Inactive - HDLC Channel 2**
Neither flags as interframe time fill nor frames are received via the signaling time slot.
- CEC2** **Command Executing - HDLC Channel 2**
0 = No command is currently executed, the CMDR3 register can be written to.
1 = A command (written previously to CMDR3) is currently executed, no further command can be temporarily written in CMDR3 register.
Note: CEC2 will be active up to 2.5 periods of the current system data rate.

Receive Signaling Status Register 2 (Read)

Value after reset: 00_H

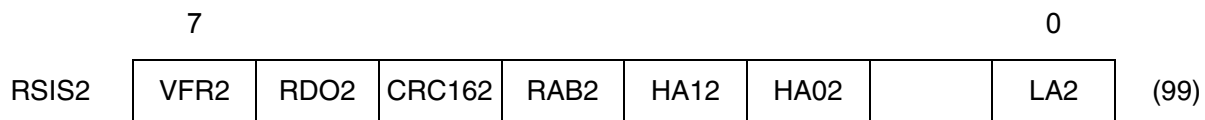

RSIS2 relates to the last received HDLC channel 2 frame; it is copied into RFIFO2 when end-of-frame is recognized (last byte of each stored frame).

- VFR2** **Valid Frame - HDLC Channel 2**
Determines whether a valid frame has been received.
1 = Valid
0 = Invalid
An invalid frame is either
– a frame which is not an integer number of 8 bits ($n \times 8$ bits) in length (e.g. 25 bits), or
– a frame which is too short taking into account the operation mode selected via MODE2 (MDS2(2:0)) and the selection of receive CRC ON/OFF (CCR3.RCRC2) as follows:
- MDS2(2:0) = 011 (16 bit Address),
RCRC2=0 : 4 bytes; RCRC2=1 : 3 or 4 bytes

- MDS2(2:0) = 010 (8 bit Address),
RCRC2=0 : 3 bytes; RCRC2=1 : 2 or 3 bytes

Note: Shorter frames are not reported.

RDO2

Receive Data Overflow - HDLC Channel 2

A data overflow has occurred during reception of the frame.

Additionally, an interrupt can be generated (refer to ISR4.RDO2/IMR4.RDO2).

CRC162

CRC16 Compare/Check - HDLC Channel 2

0 = CRC check failed; received frame contains errors.

1 = CRC check o.k.; received frame is error-free.

RAB2

Receive Message Aborted - HDLC Channel 2

This bit is set, if more than 5 contiguous 1-bits are detected.

HA12, HA02

High Byte Address Compare - HDLC Channel 2

Significant only if 2-byte address mode is selected.

In operating modes which provide high byte address recognition, the FALC[®] compares the high byte of a 2-byte address with the contents of two individually programmable registers (RAH1, RAH2) and the fixed values FE_H and FC_H (broadcast address).

Depending on the result of this comparison, the following bit combinations are possible:

00 = RAH2 has been recognized

01 = Broadcast address has been recognized

10 = RAH1 has been recognized C/R=0 (bit 1)

11 = RAH1 has been recognized C/R=1 (bit 1)

Note: If RAH1, RAH2 contain identical values, a match is indicated by "10" or "11".

LA2 Low Byte Address Compare - HDLC Channel 2

Significant in HDLC modes only.

The low byte address of a 2-byte address field, or the single address byte of a 1-byte address field is compared with two registers. (RAL1, RAL2).

0 = RAL2 has been recognized

1 = RAL1 has been recognized

Signaling Status Register 3 (Read)

Value after reset: 00_H

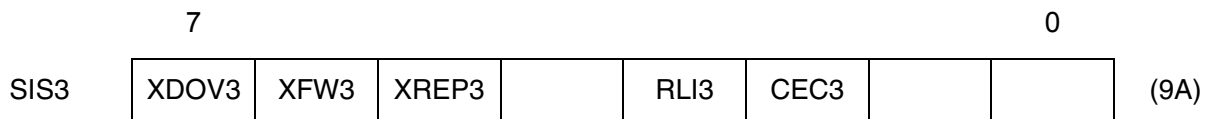

XDOV3 Transmit Data Overflow - HDLC Channel 3

More than 32 bytes have been written to the XFIFO3.

This bit is reset

- by a transmitter reset command XRES or
- when all bytes in the accessible half of the XFIFO3 have been moved in the inaccessible half.

XFW3 Transmit FIFO Write Enable - HDLC Channel 3

Data can be written to the XFIFO3.

XREP3 Transmission Repeat - HDLC Channel 3

Status indication of CMDR3.XREP3.

RLI3 Receive Line Inactive - HDLC Channel 3

Neither flags as interframe time fill nor frames are received via the signaling time slot.

CEC3 Command Executing - HDLC Channel 3

0 = No command is currently executed, the CMDR4 register can be written to.

1 = A command (written previously to CMDR4) is currently executed, no further command can be temporarily written in CMDR4 register.

Note: CEC3 will be active at most 2.5 periods of the current system data rate.

Receive Signaling Status Register 3 (Read)

Value after reset: 00_H

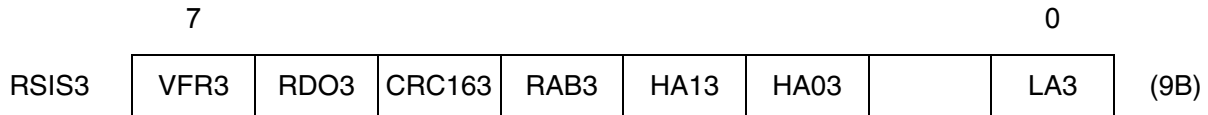

RSIS3 relates to the last received HDLC channel 3 frame; it is copied into RFIFO3 when end-of-frame is recognized (last byte of each stored frame).

VFR3 Valid Frame - HDLC Channel 3

Determines whether a valid frame has been received.

- 1 = Valid
- 0 = Invalid

An invalid frame is either

- a frame which is not an integer number of 8 bits (n×8 bits) in length (e.g. 25 bits), or
- a frame which is too short taking into account the operation mode selected via MODE3 (MDS3(2:0)) and the selection of receive CRC ON/OFF (CCR4.RCRC3) as follows:
 - MDS3(2:0)=011 (16 bit Address),
RCRC3=0: 4 bytes; RCRC3=1: 3 or 4 bytes
 - MDS3(2:0)=010 (8 bit Address),
RCRC3=0: 3 bytes; RCRC3=1: 2 or 3 bytes

Note: Shorter frames are not reported.

RDO3 Receive Data Overflow - HDLC Channel 3

A data overflow has occurred during reception of the frame.

Additionally, an interrupt can be generated (refer to ISR5.RDO3/IMR5.RDO3).

CRC163 CRC16 Compare/Check - HDLC Channel 3

- 0 = CRC check failed; received frame contains errors.
- 1 = CRC check o.k.; received frame is error-free.

RAB3 Receive Message Aborted - HDLC Channel 3

This bit is set, if more than 5 contiguous 1-bits are detected.

HA13, HA03

High Byte Address Compare - HDLC Channel 3

Significant only if 2-byte address mode is selected.

In operating modes which provide high byte address recognition, the FALC[®] compares the high byte of a 2-byte address with the contents of two individually programmable registers (RAH1, RAH2) and the fixed values FE_H and FC_H (broadcast address).

Depending on the result of this comparison, the following bit combinations are possible:

00 = RAH2 has been recognized

01 = Broadcast address has been recognized

10 = RAH1 has been recognized C/R=0 (bit 1)

11 = RAH1 has been recognized C/R=1 (bit 1)

Note: If RAH1, RAH2 contain identical values, a match is indicated by "10" or "11".

LA3

Low Byte Address Compare - HDLC Channel 3

Significant in HDLC modes only.

The low byte address of a 2-byte address field, or the single address byte of a 1-byte address field is compared with two registers. (RAL1, RAL2).

0 = RAL2 has been recognized

1 = RAL1 has been recognized

Receive FIFO 2 (Read)

Value after reset: 00_H

	7		0	
RFIFO2	RF7		RF0	(9C)
RFIFO2	RF15		RF8	(9D)

RF(15:0) Receive FIFO - HDLC Channel 2

The function is equivalent to RFIFO of HDLC channel 1.

Receive FIFO 3 (Read)

Value after reset: 00_H

	7		0	
RFIFO3	RF7		RF0	(9E)
RFIFO3	RF15		RF8	(9F)

RF(15:0) Receive FIFO - HDLC Channel 3

The function is equivalent to RFIFO of HDLC channel 1.

Identification Register (Read)

Value after reset: xxxxxx11

	7		0						
WID	x	x	x	x	x	x	1	1	(EC)

Additional version identification register.

11 Electrical Characteristics

11.1 Absolute Maximum Ratings

Parameter	Symbol	Limit Values	Unit
Ambient temperature under bias	T_A	- 40 to 85	°C
Storage temperature	T_{stg}	- 65 to 125	°C
IC supply voltage (digital)	V_{DD}	- 0.4 to 6.5	V
IC supply voltage receive (analog)	V_{DDR}	- 0.4 to 6.5	V
IC supply voltage transmit (analog)	V_{DDX}	- 0.4 to 6.5	V
Voltage on any pin with respect to ground	V_S	- 0.4 to 6.5	V
ESD robustness ¹⁾ HBM: 1.5 kΩ, 100 pF	$V_{ESD,HBM}$	2000	V

¹⁾ According to JEDEC standard JESD22-A114.

Note: Stresses above those listed here may cause permanent damage to the device. Exposure to absolute maximum rating conditions for extended periods may affect device reliability.

11.2 Operating Range

Parameter	Symbol	Limit Values		Unit	Test Condition
		min.	max.		
Ambient temperature	T_A	-40	85	°C	
Supply voltages	V_{DD} V_{DDR} V_{DDX}	3.13	3.46	V	3.3 V ± 5% 1)
Analog input voltages	V_{IA}	0	$V_{DDR}+0.3$	V	
Digital input voltages	V_{ID}	0	5.25	V	$V_{DD} = 5.0 V \pm 5\%$
Ground	V_{SS} V_{SSR} V_{SSX}	0	0	V	

¹⁾ Voltage ripple on analog supply less than 50 mV

Note: In the operating range, the functions given in the circuit description are fulfilled.

V_{DD} , V_{DDR} and V_{DDX} have to be connected to the same voltage level,
 V_{SS} , V_{SSR} and V_{SSX} have to be connected to ground level.

Electrical Characteristics
11.3 DC Characteristics

Parameter	Symbol	Limit Values		Unit	Notes
		min.	max.		
Input low voltage	V_{IL}	-0.4	0.8	V	1)
Input high voltage	V_{IH}	2.0	5.25	V	1)
Output low voltage	V_{OL}	V_{SS}	0.45	V	$I_{OL} = +2 \text{ mA}$ ²⁾
Output high voltage	V_{OH}	2.4	V_{DD}	V	$I_{OH} = -2 \text{ mA}$ ²⁾
Average power supply current (analog line interface mode)	I_{DDE1}		145	mA	E1 application ³⁾ LIM1.DRS=0
		typ. 80			
	I_{DDT1}		145	mA	T1 application ⁴⁾ LIM1.DRS=0
		typ. 80			
Average power supply current (digital line interface mode)	I_{DD}		90	mA	LIM1.DRS=1 ⁵⁾
		typ. 50			
Input leakage current	I_{IL11}		1	μA	$V_{IN} = V_{DD}$ ⁶⁾ ; all except RDO
Input leakage current	I_{IL12}		1	μA	$V_{IN} = V_{SS}$ ⁶⁾ ; all except RDO
Input pullup current	I_{IP}	2	15	μA	$V_{IN} = V_{SS}$
Output leakage current	I_{OZ1}		1	μA	$V_{OUT} = \text{tristate}$ ¹⁾ $V_{SS} < V_{meas} < V_{DD}$ measured against V_{DD} and V_{SS} ; all except XL1/2
Transmitter leakage current	I_{TL}		2.5	μA	XL1/2 = V_{DDX} ; XPM2.XLT = 1
			2.5	μA	XL1/2 = V_{SSX} ; XPM2.XLT = 1
Transmitter output impedance	R_X		3	Ω	applies to XL1 and XL2 ⁷⁾
Transmitter output current	I_X		105	mA	XL1, XL2
Differential peak voltage of a mark (between XL1 and XL2)	V_X		2.15	V	

Electrical Characteristics

Parameter	Symbol	Limit Values		Unit	Notes
		min.	max.		
Receiver differential peak voltage of a mark (between RL1 and RL2)	V_R		$V_{DDR}+0.3$	V	RL1, RL2
Receiver input impedance	Z_R	50 (typical value)		k Ω	⁸⁾
Receiver sensitivity	S_{RSH}	0	10	dB	RL1, RL2 LIM0.EQON=0 (short-haul)
Receiver sensitivity	S_{RLH}	0	43	dB	RL1, RL2 LIM0.EQON=1 (E1, long-haul)
		0	36		RL1, RL2 LIM0.EQON=1 (T1/J1, long-haul)
Receiver input threshold	V_{RTH}	45		%	LIM2.SLT(1:0)=11 ⁷⁾
		50			LIM2.SLT(1:0)=10 default setting ⁷⁾
		55			LIM2.SLT(1:0)=00 ⁷⁾
		67			LIM2.SLT(1:0)=01 ⁷⁾

Electrical Characteristics

Parameter	Symbol	Limit Values		Unit	Notes
		min.	max.		
Loss-Of-signal (LOS) detection limit in short-haul mode	V_{LOSSH}	0.91		V	RIL(2:0)=000
		0.74			RIL(2:0)=001
		0.59			RIL(2:0)=010
		0.42			RIL(2:0)=011
		0.32			RIL(2:0)=100
		0.21			RIL(2:0)=101
		0.16			RIL(2:0)=110
		0.10			RIL(2:0)=111
	(typical values)			7) 8)	
LOS detection limit in long-haul mode	V_{LOSLH}	1.70		V	RIL(2:0)=000
		0.84			RIL(2:0)=001
		0.84			RIL(2:0)=010
		0.45			RIL(2:0)=011
		0.45			RIL(2:0)=100
		0.20			RIL(2:0)=101
		0.10			RIL(2:0)=110
		not defined			RIL(2:0)=111
	(typical values)			7) 8)	

- 1) Applies to all input pins except analog pins RLx
- 2) Applies to all output pins except pins XLx
- 3) Wiring conditions and external circuit configuration according to [Figure 107](#) and [Table 90](#) on [page 476](#).
- 4) Wiring conditions and external circuit configuration according to [Figure 107](#) and [Table 91](#) on [page 477](#).
- 5) System interface at 16 MHz; all-ones data.
- 6) Pin leakage is measured in a test mode with all internal pullups disabled. RDO pins are not tristatable, no leakage is measured.
- 7) Parameter not tested in production
- 8) Differential input voltage between pins RL1 and RL2; depends on programming of register LIM1.RIL(2:0)

Note: Typical characteristics specify mean values expected over the production spread. If not specified otherwise, typical characteristics apply at $T_A=25\text{ }^\circ\text{C}$ and 3.3V supply voltage.

11.4 AC Characteristics

11.4.1 Master Clock Timing

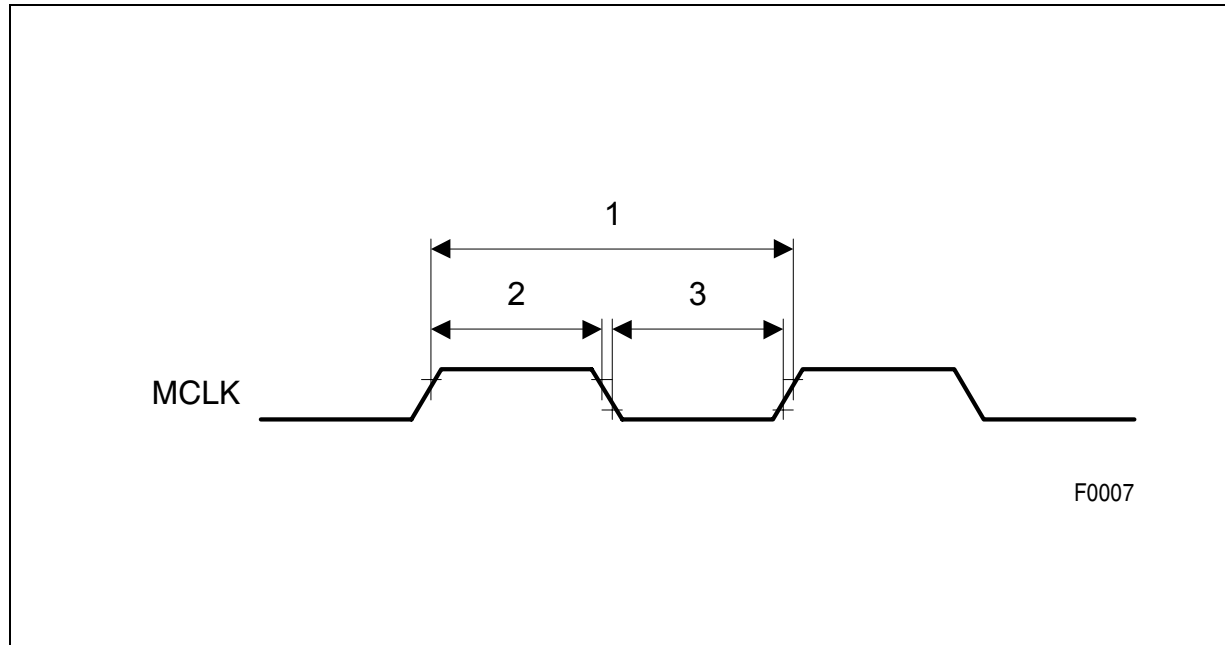

Figure 81 MCLK Timing

Table 70 MCLK Timing Parameters

No.	Parameter	Limit Values			Unit	Condition
		min.	typ.	max.		
1	Clock period of MCLK		488		ns	E1, fixed mode
			648		ns	T1/J1, fixed mode
		50		980.4	ns	E1/T1/J1, flexible mode
2	High phase of MCLK	40			%	
3	Low phase of MCLK	40			%	
	Clock accuracy	32 ¹⁾		28 ²⁾	ppm	

¹⁾ if clock divider programming fits without rounding

²⁾ if clock divider programming requires rounding

11.4.2 JTAG Boundary Scan Interface

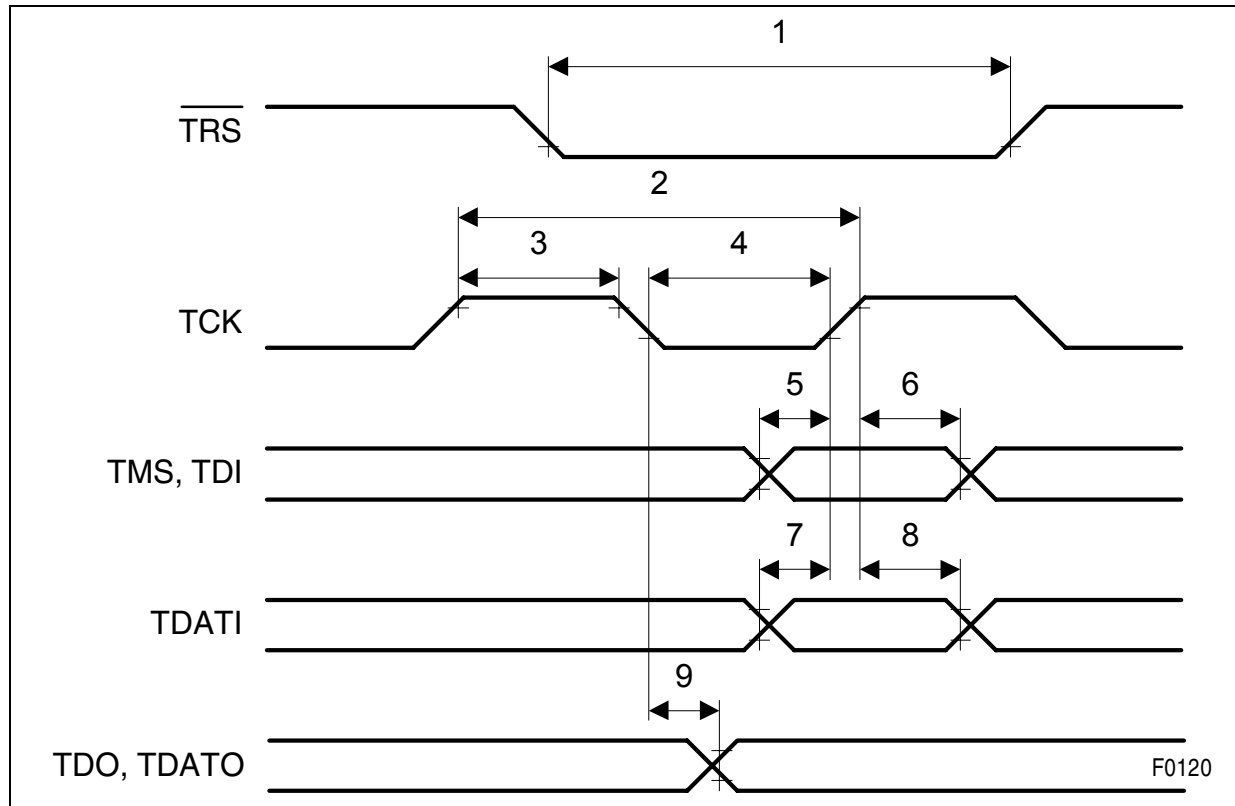

Figure 82 JTAG Boundary Scan Timing

Table 71 JTAG Boundary Scan Timing Parameter Values

No.	Parameter	Limit Values		Unit
		min.	max.	
1	$\overline{\text{TRS}}$ reset active low time	200		ns
2	TCK period	250		ns
3	TCK high time	80		ns
4	TCK low time	80		ns
5	TMS, TDI setup time	40		ns
6	TMS, TDI hold time	40		ns
7	TDATI setup time	40		ns
8	TDATI hold time	40		ns
9	TDO, TDATO output delay		100	ns

Identification Register: 32 bit; Version: 3_H; Part Number: 59_H, Manufacturer: 083_H

11.4.3 Reset

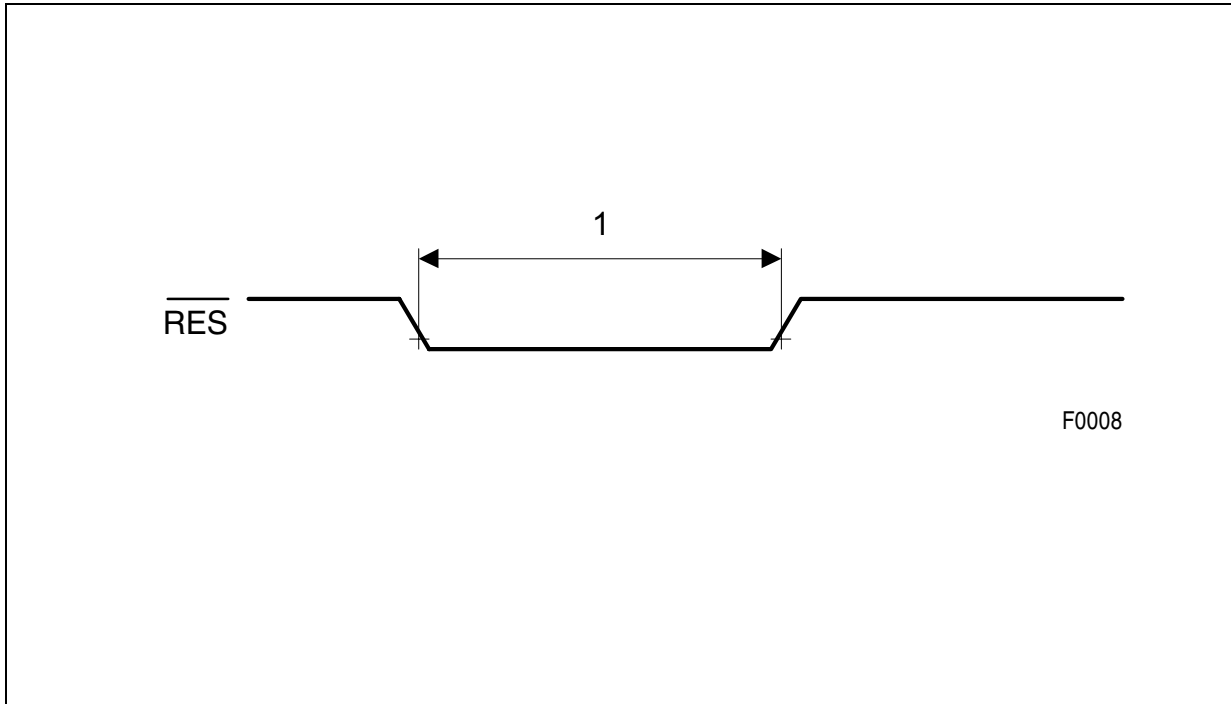

Figure 83 Reset Timing

Table 72 Reset Timing Parameter Values

No.	Parameter	Limit Values		Unit
		min.	max.	
1	$\overline{\text{RES}}$ pulse width low	10 ¹⁾		μs

¹⁾ while MCLK is running

11.4.4 Microprocessor Interface

11.4.4.1 Intel Bus Interface Mode

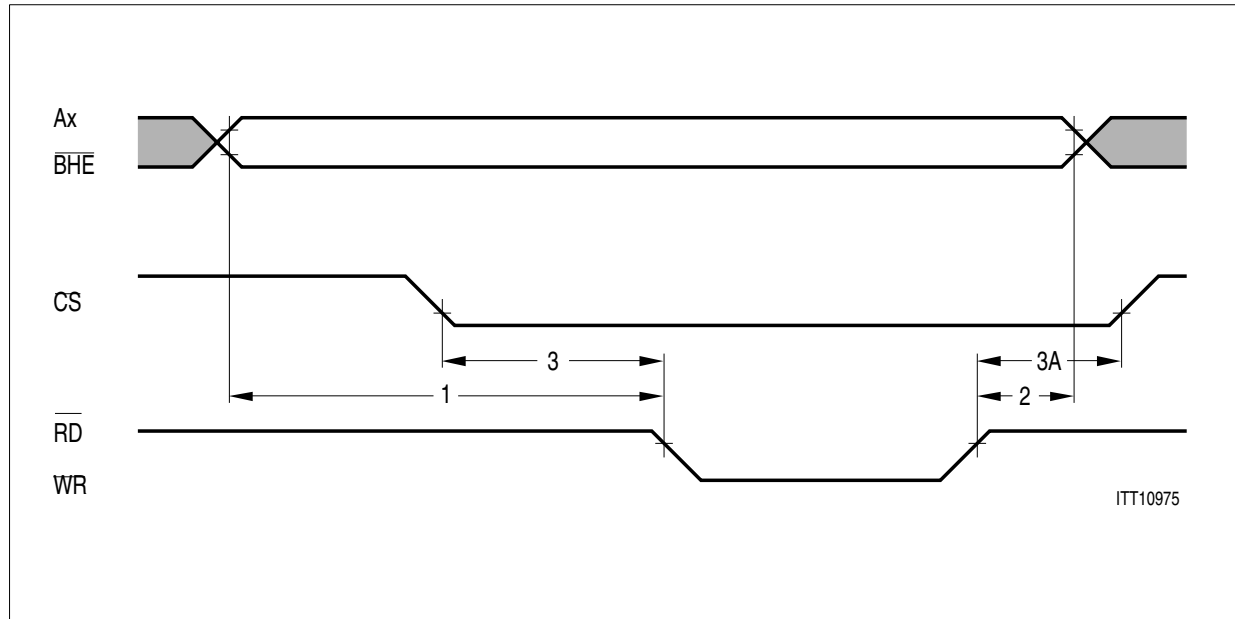

Figure 84 Intel Non-Multiplexed Address Timing

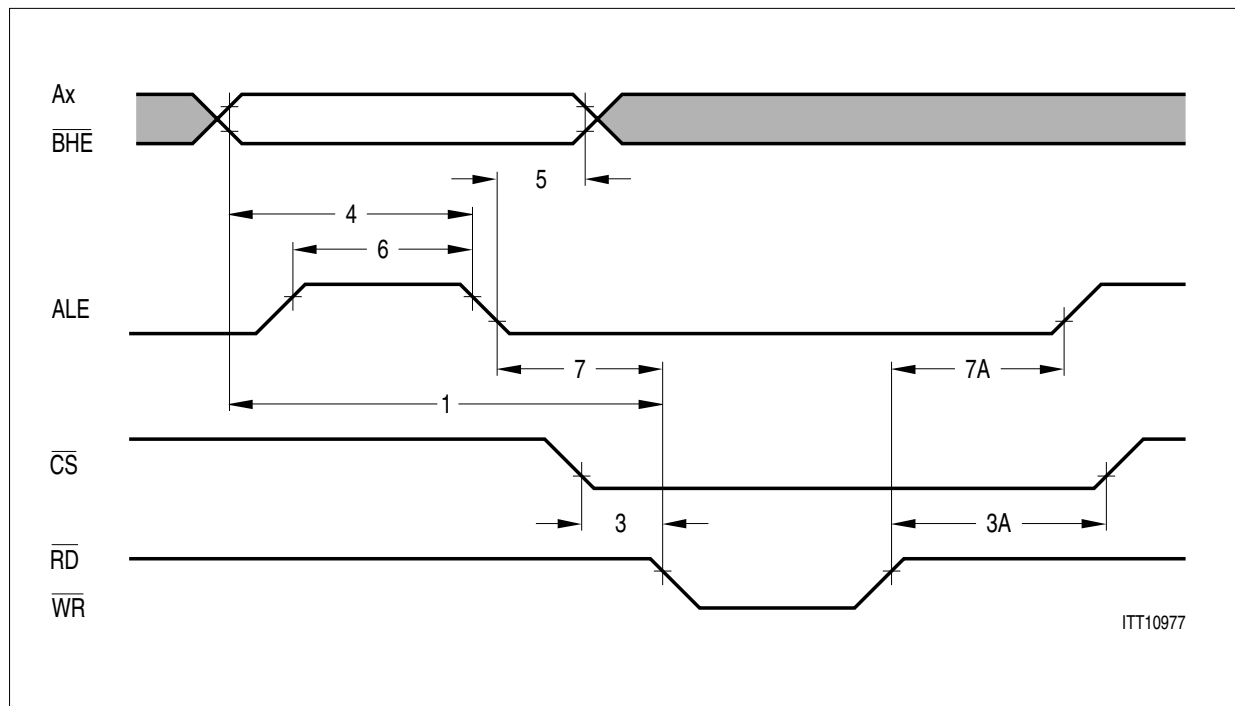

Figure 85 Intel Multiplexed Address Timing

Electrical Characteristics

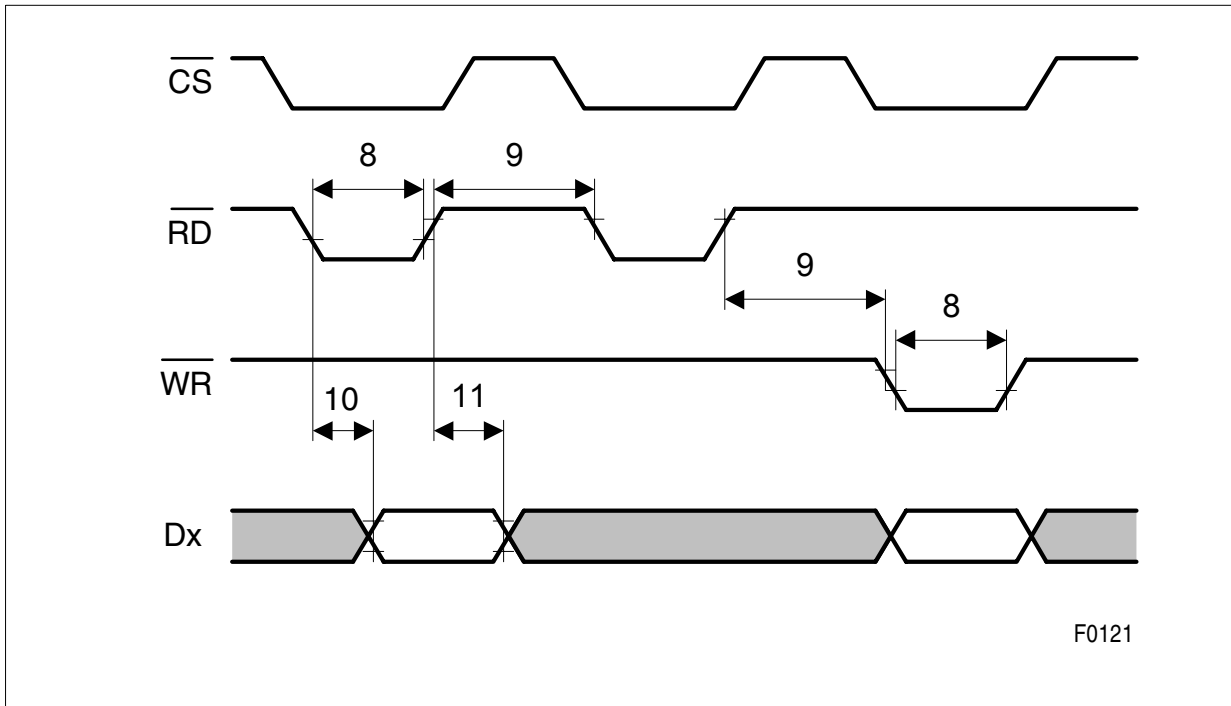

Figure 86 Intel Read Cycle Timing

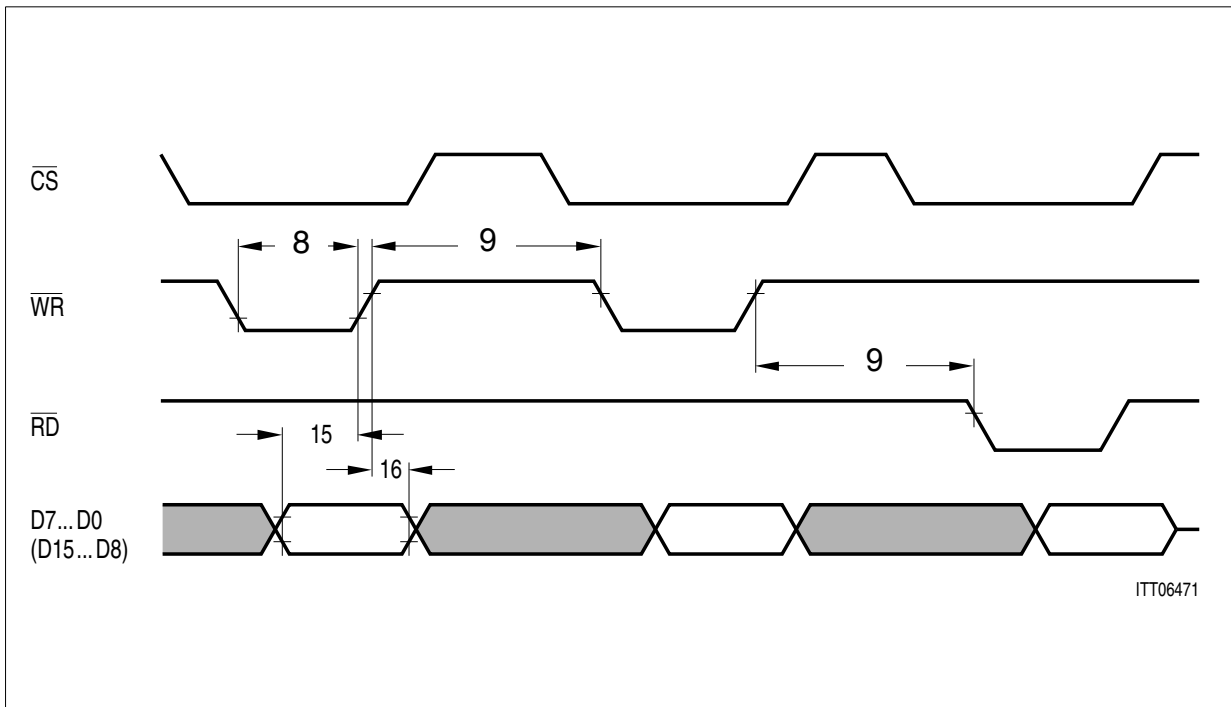

Figure 87 Intel Write Cycle Timing

Electrical Characteristics

Table 73 Intel Bus Interface Timing Parameter Values

No.	Parameter	Limit Values		Unit
		min.	max.	
1	Address, $\overline{\text{BHE}}$ setup time	5		ns
2	Address, $\overline{\text{BHE}}$ hold time	0		ns
3	$\overline{\text{CS}}$ setup time	0		ns
3A	$\overline{\text{CS}}$ hold time	0		ns
4	Address, $\overline{\text{BHE}}$ stable before ALE inactive	20		ns
5	Address, $\overline{\text{BHE}}$ hold after ALE inactive	10		ns
6	ALE pulse width	30		ns
7	ALE setup time before command active	0		ns
7A	ALE to command inactive delay	30		ns
8	$\overline{\text{RD}}$, $\overline{\text{WR}}$ pulse width	80		ns
9	$\overline{\text{RD}}$, $\overline{\text{WR}}$ control interval	70		ns
10	Data valid after $\overline{\text{RD}}$ active		75	ns
11	Data hold after $\overline{\text{RD}}$ inactive	10	30	ns
15	Data stable before $\overline{\text{WR}}$ inactive	30		ns
16	Data hold after $\overline{\text{WR}}$ inactive	10		ns

11.4.4.2 Motorola Bus Interface Mode

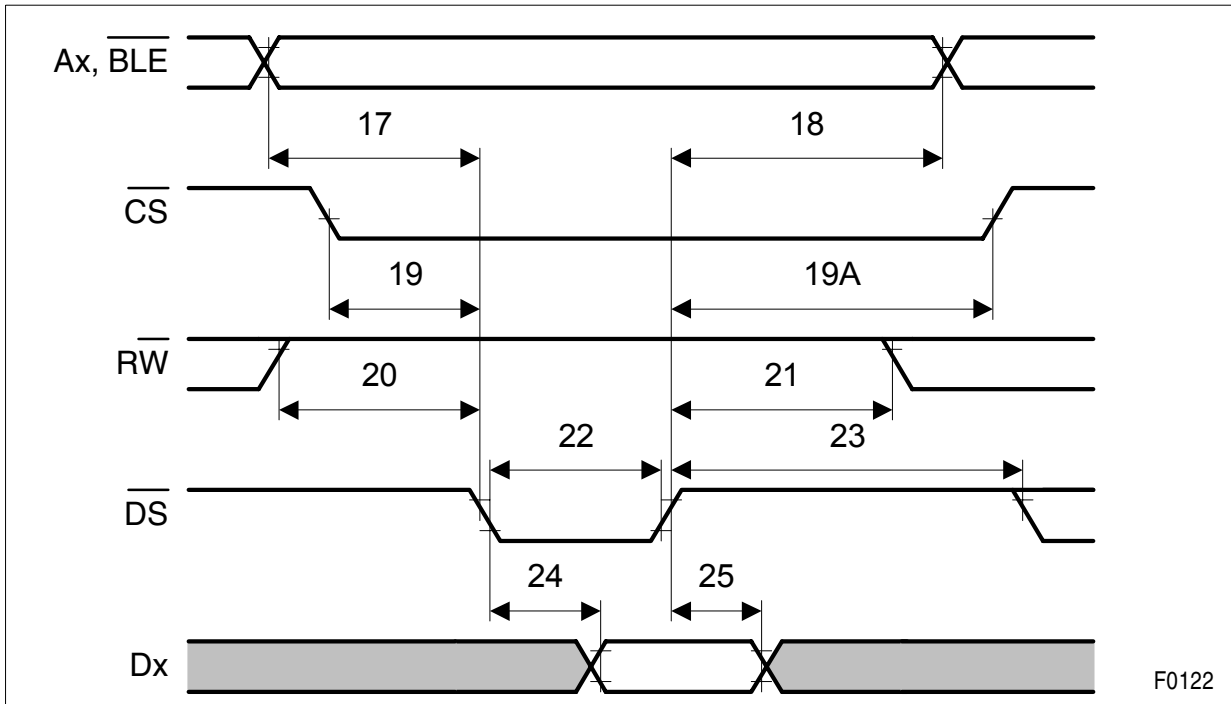

Figure 88 Motorola Read Cycle Timing

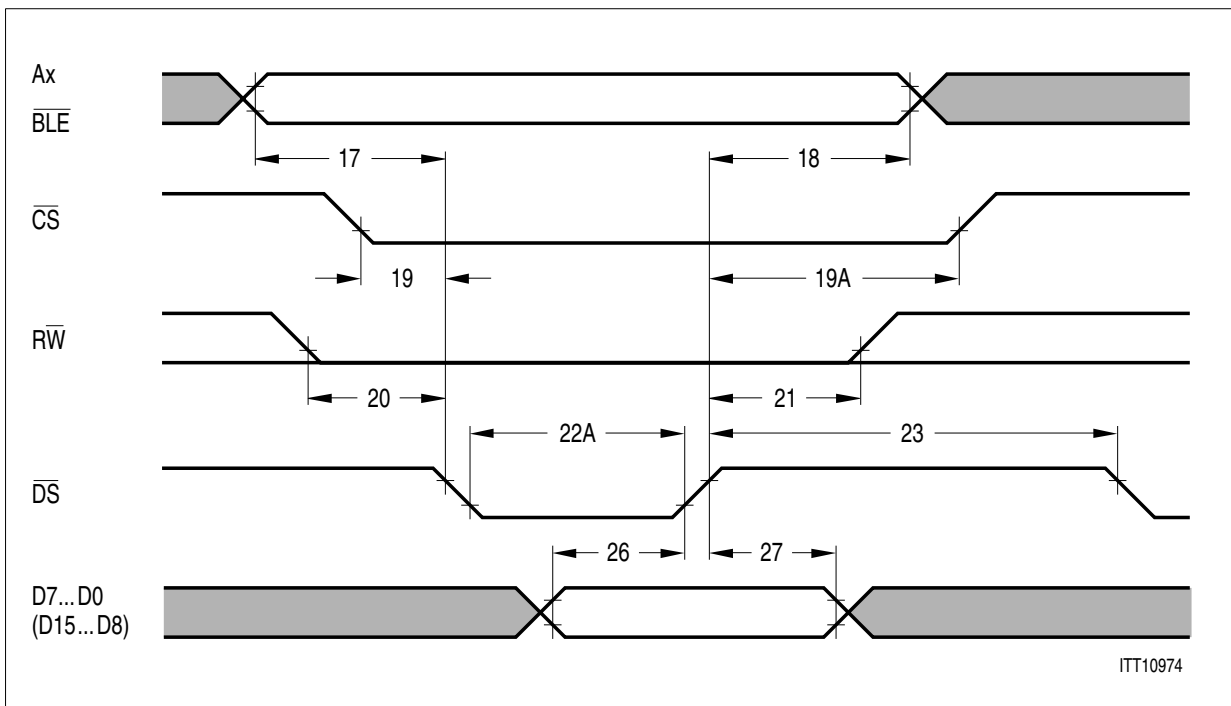

Figure 89 Motorola Write Cycle Timing

Electrical Characteristics

Table 74 Motorola Bus Interface Timing Parameter Values

No.	Parameter	Limit Values		Unit
		min.	max.	
17	Address, \overline{BLE} setup time before \overline{DS} active	15		ns
18	Address, \overline{BLE} hold after \overline{DS} inactive	0		ns
19	\overline{CS} active before \overline{DS} active	0		ns
19A	\overline{CS} hold after \overline{DS} inactive	0		ns
20	\overline{RW} stable before \overline{DS} active	10		ns
21	\overline{RW} hold after \overline{DS} inactive	0		ns
22	\overline{DS} pulse width (read access)	80		ns
22A	\overline{DS} pulse width (write access)	70		ns
23	\overline{DS} control interval	70		ns
24	Data valid after \overline{DS} active (read access)		75	ns
25	Data hold after \overline{DS} inactive (read access)	10	30	ns
26	Data stable before \overline{DS} active (write access)	30		ns
27	Data hold after \overline{DS} inactive (write access)	10		ns

11.4.5 Line Interface

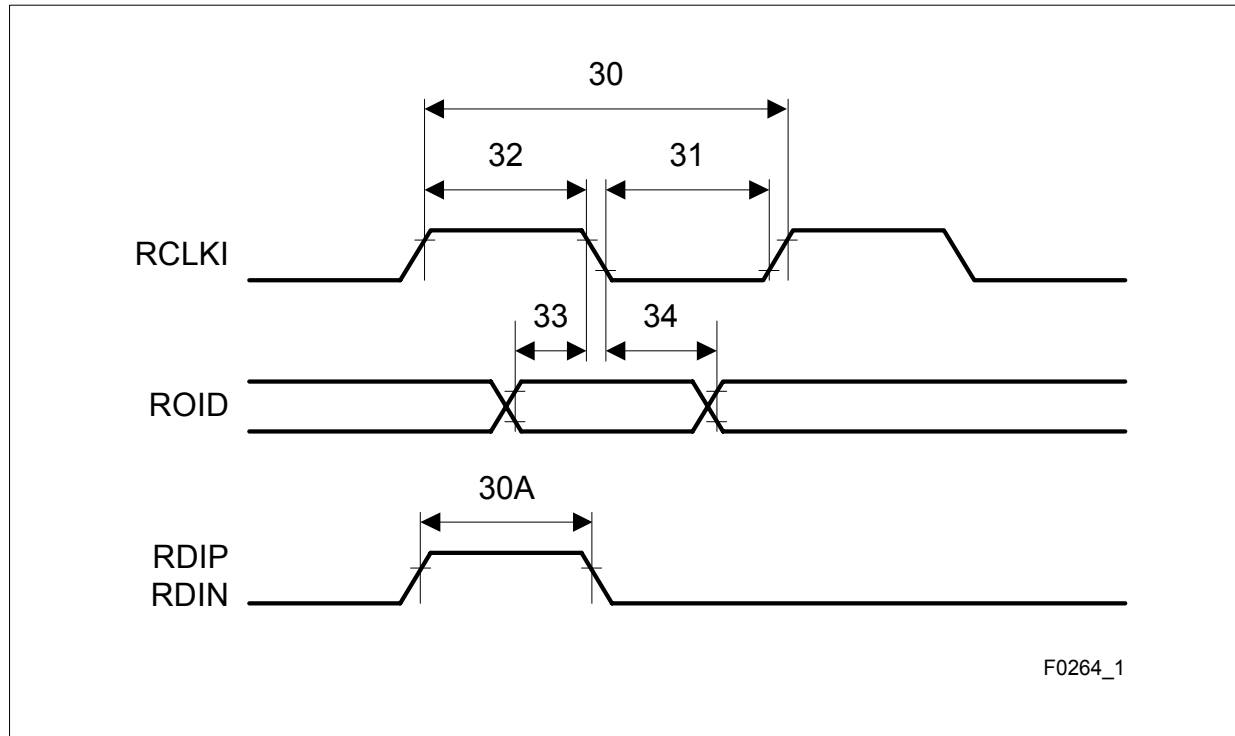

Figure 90 Digital Line Interface Receive Timing

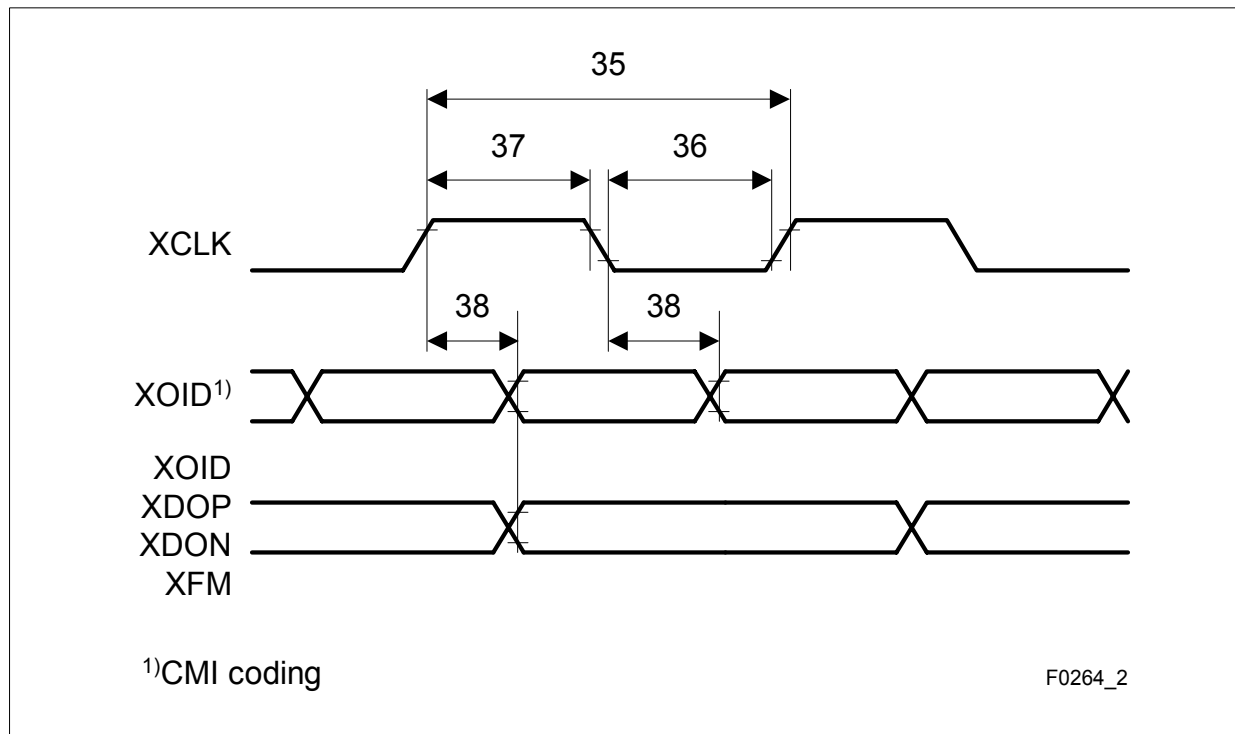

Figure 91 Digital Line Interface Transmit Timing

Electrical Characteristics
Table 75 Digital Line Interface Parameter Values

No.	Parameter	Limit Values						Unit
		E1			T1			
		min.	typ.	max.	min.	typ.	max.	
30	RCLKI clock period		488			648		ns
30A	RDIP/RDIN period high	122	244	366	162	324	486	ns
31	RCLKI clock period low	180			240			ns
32	RCLKI clock period high	180			240			ns
33	ROID setup	50			50			ns
34	ROID hold	50			50			ns
35	XCLK clock period		488			648		ns
36	XCLK clock period low	190			230			ns
	XCLK clock period low ¹⁾	150			200			
37	XCLK clock period high	190			230			ns
	XCLK clock period high ¹⁾	150			200			
38	XOID delay ²⁾			60			60	ns
	XDOP/XDON delay ³⁾							

¹⁾ depends on input RCLKI in optical interface and remote loop without transmit jitter attenuator enabled (LIM1.JATT/RL=01)

²⁾ NRZ coding

³⁾ HDB3/AMI/B8ZS coding

11.4.6 System Interface

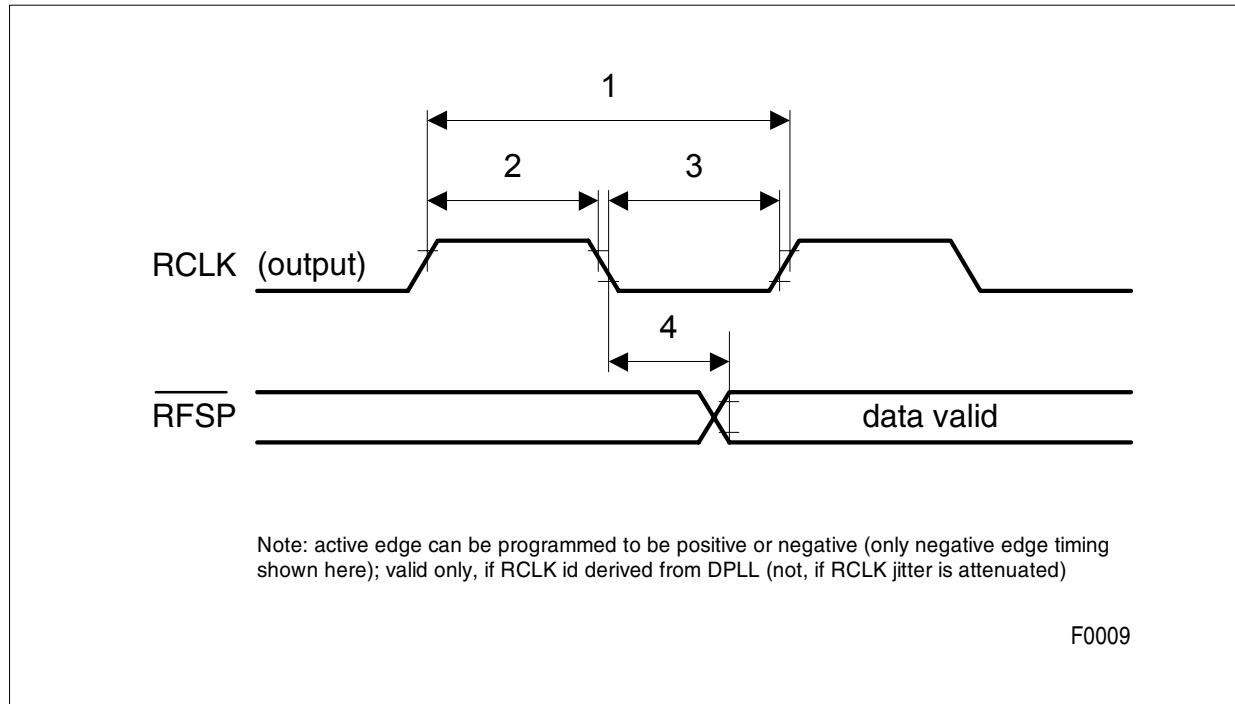

Figure 92 RCLK, RFSP Output Timing

Table 76 RCLK, RFSP Timing Parameter Values

No.	Parameter	Limit Values			Unit
		min.	typ.	max.	
1	RCLK period E1 (2.048 MHz)		488		ns
	RCLK period E1 (2.048 MHz × 4)		122		ns
	RCLK period T1/J1 (1.544 MHz)		648		ns
	RCLK period T1/J1 (1.544 MHz × 4)		162		ns
2	RCLK pulse high	40		60	%
3	RCLK pulse low	40		60	%
4	RFSP delay			80	ns

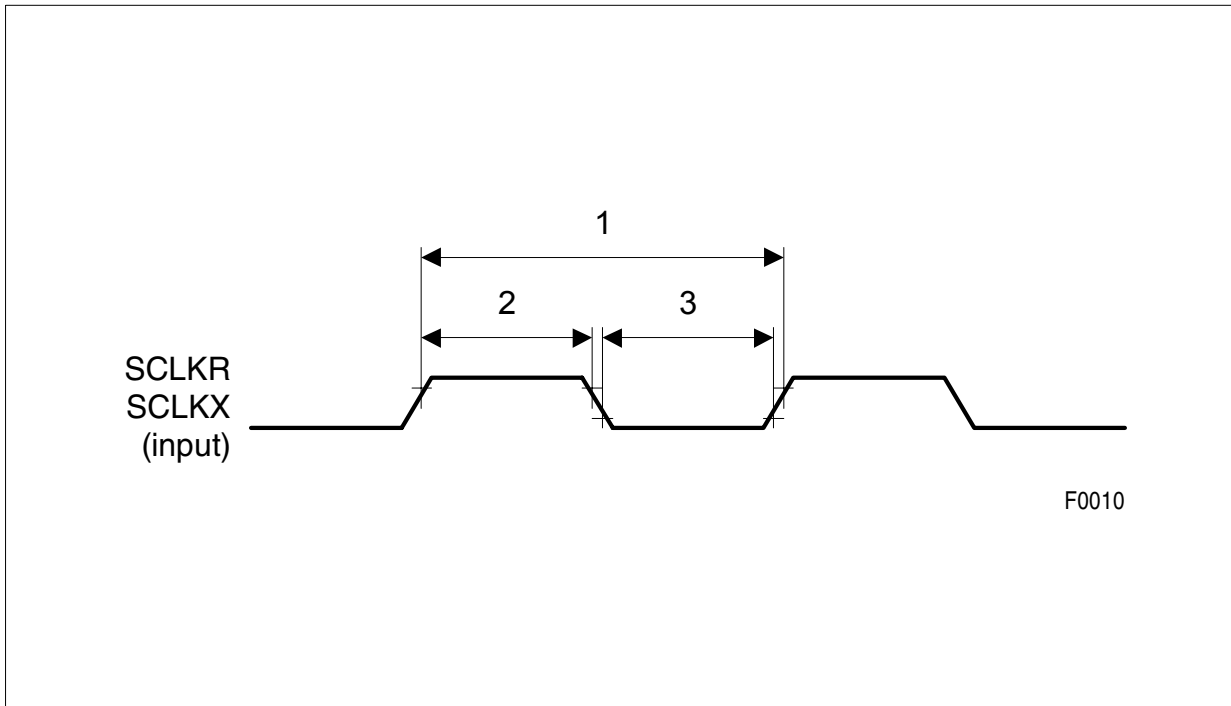

Figure 93 SCLKR/SCLKX Input Timing

Table 77 SCLKR/SCLKX Timing Parameter Values

No.	Parameter	Limit Values			Unit
		min.	typ.	max.	
1	SCLKR/SCLKX period at 16.384 MHz		61		ns
1	SCLKR/SCLKX period at 8.192 MHz		122		ns
1	SCLKR/SCLKX period at 4.096 MHz		244		ns
1	SCLKR/SCLKX period at 2.048 MHz		488		ns
1	SCLKR/SCLKX period at 12.352 MHz		81		ns
1	SCLKR/SCLKX period at 6.176 MHz		162		ns
1	SCLKR/SCLKX period at 3.088 MHz		324		ns
1	SCLKR/SCLKX period at 1.544 MHz		648		ns
2	SCLKR/SCLKX pulse high	40			%
3	SCLKR/SCLKX pulse low	40			%

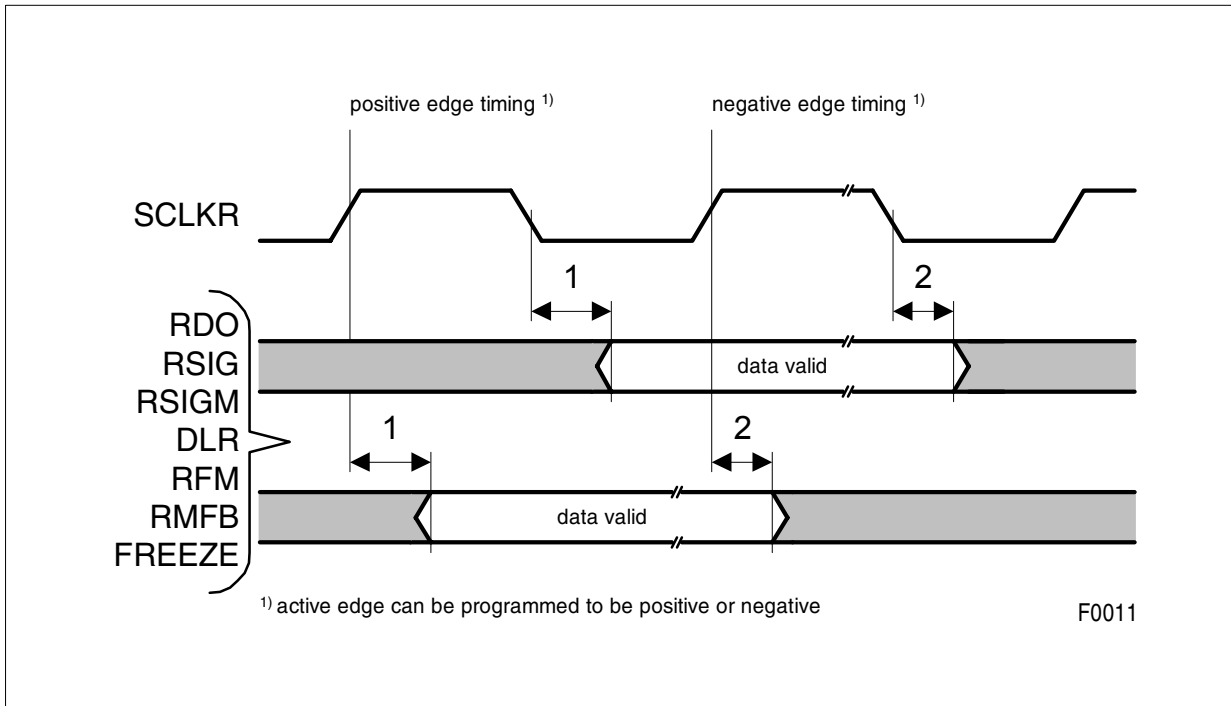

Figure 94 System Interface Marker Timing (Receive)

Table 78 System Interface Marker Timing Parameter Values

No.	Parameter	Limit Values			Unit
		min.	typ.	max.	
SCLKR input mode					
1	RDO delay	0		35	ns
2	RSIGM, RMFB, DLR, RFM, FREEZE, RSIG marker delay	0		45	ns
SCLKR output mode					
1A	RDO delay	-55		-20	ns
2A	RSIGM, RMFB, DLR, RFM, FREEZE, RSIG marker delay	-55		-20	ns

SCLKR can be input or output.

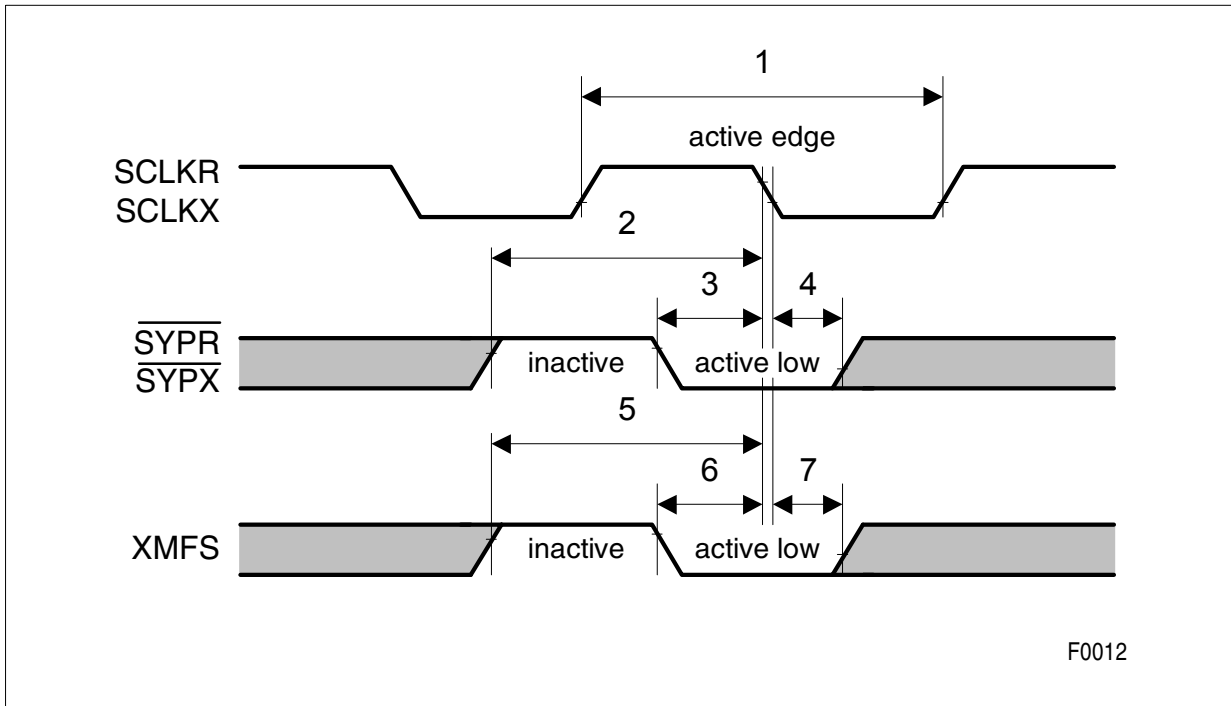

Figure 95 $\overline{\text{SYPR}}$, $\overline{\text{SYPX}}$ Timing

Table 79 $\overline{\text{SYPR}}$ / $\overline{\text{SYPX}}$ Timing Parameter Values

No.	Parameter	Limit Values			Unit
		min.	typ. ¹⁾	max.	
SCLKR input mode					
1	SCLKR period (t_1)	61		648	ns
2	$\overline{\text{SYPR}}$ / $\overline{\text{SYPX}}$ inactive setup time	$1 \times t_1$			ns
3	$\overline{\text{SYPR}}$ / $\overline{\text{SYPX}}$ setup time	5			ns
4	$\overline{\text{SYPR}}$ / $\overline{\text{SYPX}}$ hold time	15			ns
5	XMFS inactive setup time	$1 \times t_1$			ns
6	XMFS setup time	5			ns
7	XMFS hold time	15			ns
SCLKR output mode					
1A	SCLKR period (t_1)	61		648	ns
2A	$\overline{\text{SYPR}}$ / $\overline{\text{SYPX}}$ inactive setup time	$1 \times t_1$			ns
3A	$\overline{\text{SYPR}}$ / $\overline{\text{SYPX}}$ setup time	10			ns

Electrical Characteristics

Table 79 $\overline{\text{SYPR}}/\overline{\text{SYPX}}$ Timing Parameter Values (cont'd)

No.	Parameter	Limit Values			Unit
		min.	typ. ¹⁾	max.	
4A	$\overline{\text{SYPR}}/\overline{\text{SYPX}}$ hold time	0			ns
5A	XMFS inactive setup time	$1 \times t_1$			ns
6A	XMFS setup time	10			ns
7A	XMFS hold time	0			ns

¹⁾ typical value, not tested in production

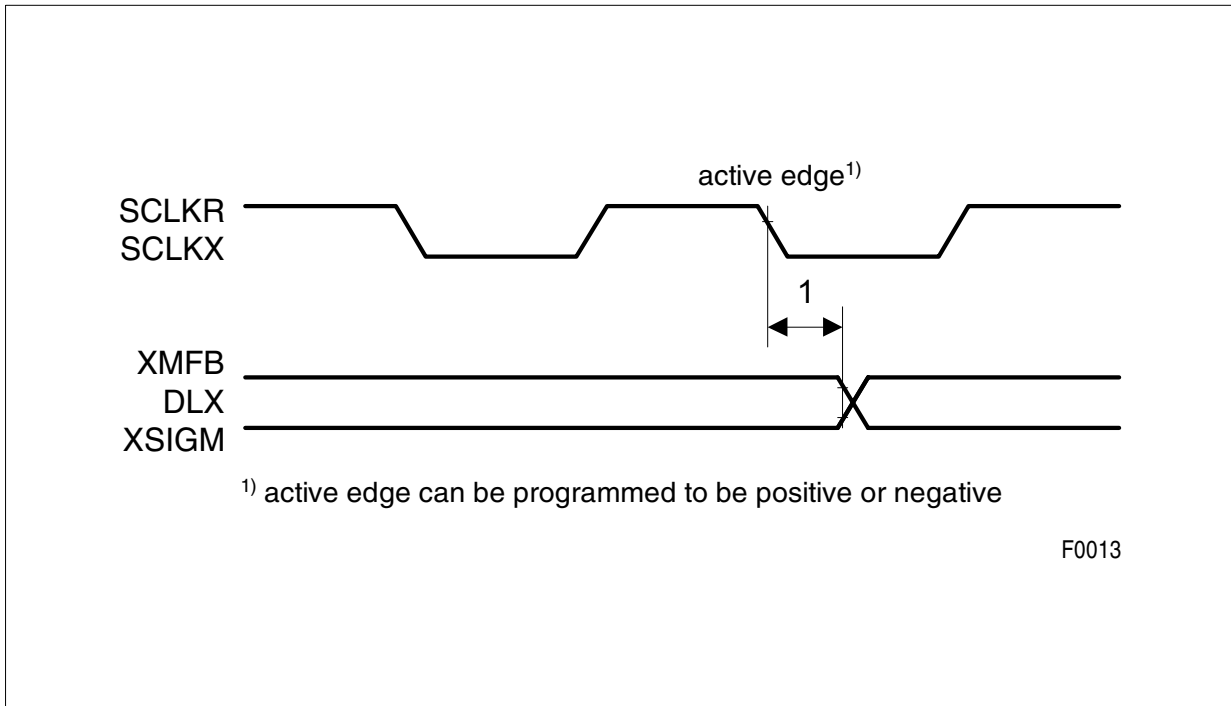

Figure 96 System Interface Marker Timing (Transmit)

Table 80 System Interface Marker Timing Parameter Values¹⁾

No.	Parameter	Limit Values			Unit
		min.	typ.	max.	
SCLKR input mode					
1	XMFB, DLX, XSIGM delay			100	ns
SCLKR output mode					
1A	XMFB, DLX, XSIGM delay			-20	ns

¹⁾ Parameters based on SCLKR when CMR2.IXSC = 1 and on SCLKX when CMR2.IXSC = 0 (input mode only)

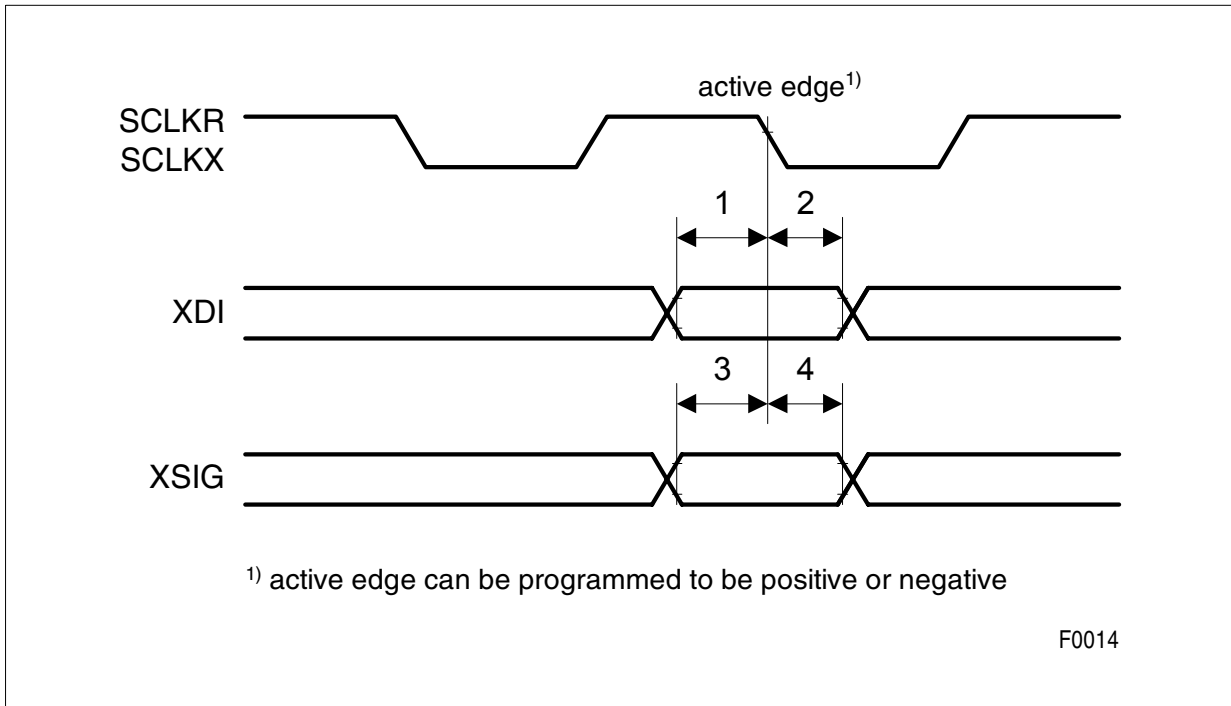
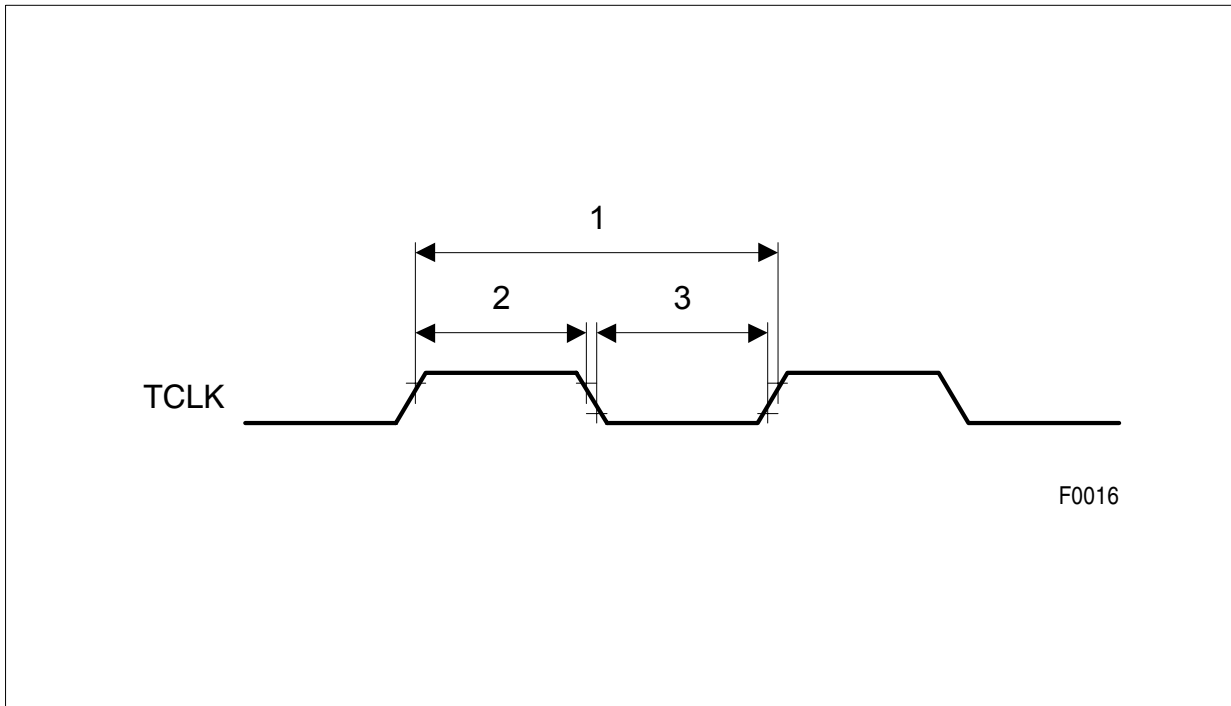

Figure 97 XDI, XSIG Timing

Table 81 XDI, XSIG Timing Parameter Values¹⁾

No.	Parameter	Limit Values			Unit
		min.	typ.	max.	
SCLKR input mode					
1	XDI setup time	5			ns
2	XDI hold time	15			ns
3	XSIG setup time	5			ns
4	XSIG hold time	15			ns
SCLKR output mode					
1A	XDI setup time	10			ns
2A	XDI hold time	20			ns
3A	XSIG setup time	10			ns
4A	XSIG hold time	20			ns

¹⁾ Parameters based on SCLKR when CMR2.IXSC = 1 and on SCLKX when CMR2.IXSC = 0 (input mode only)



F0016

Figure 98 TCLK Input Timing

Table 82 TCLK Timing Parameter Values

No.	Parameter	Limit Values			Unit
		min.	typ.	max.	
1	TCLK period E1 (2.048 MHz)		488		ns
	TCLK period E1 (2.048 MHz × 4)		122		ns
	TCLK period T1/J1 (1.544 MHz)		648		ns
	TCLK period T1/J1 (1.544 MHz × 4)		162		ns
2	TCLK high	40			%
3	TCLK low	40			%

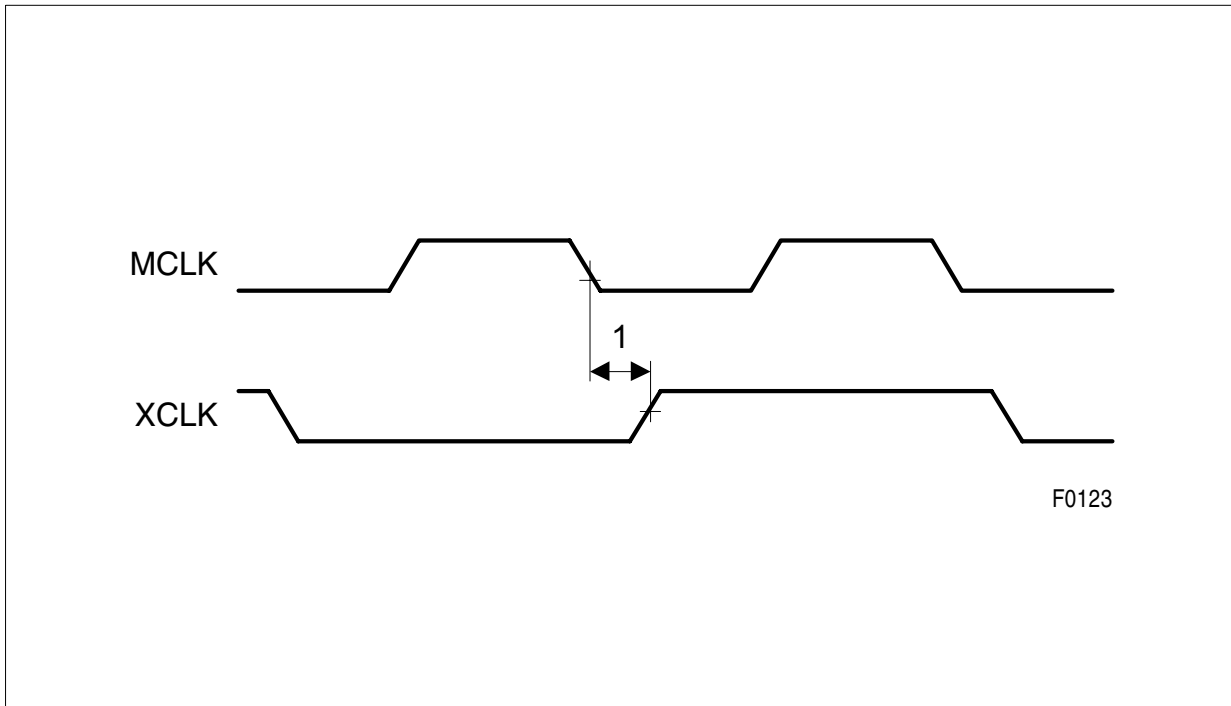

Figure 99 XCLK Timing

Table 83 XCLK Timing Parameter values

No.	Parameter	Limit Values						Unit
		E1			T1			
		min.	typ.	max.	min.	typ.	max.	
1	XCLK delay ¹⁾			100			100	ns

¹⁾ valid in transmit buffer bypass mode only

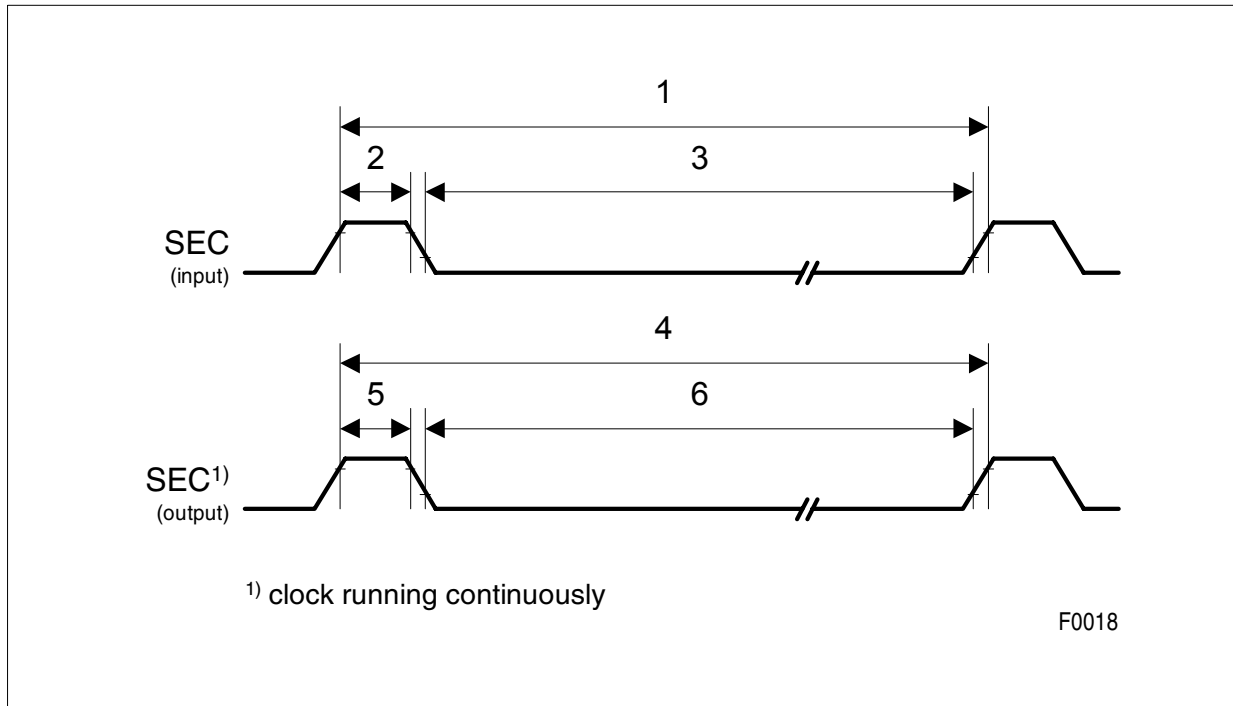

Figure 100 SEC Timing

Table 84 SEC Timing Parameter Values

No.	Parameter ¹⁾	Limit Values			Unit
		min.	typ.	max.	
1	SEC input period E1/T1/J1		1		s
2	SEC input high E1	976			ns
	SEC input high T1/J1	1296			ns
3	SEC input low E1	976			ns
	SEC input low T1/J1	1296			ns
4	SEC output period E1/T1/J1		1		s
5	SEC high output E1	976			ns
	SEC high output T1/J1	1296			ns

¹⁾ typical value, not tested in production

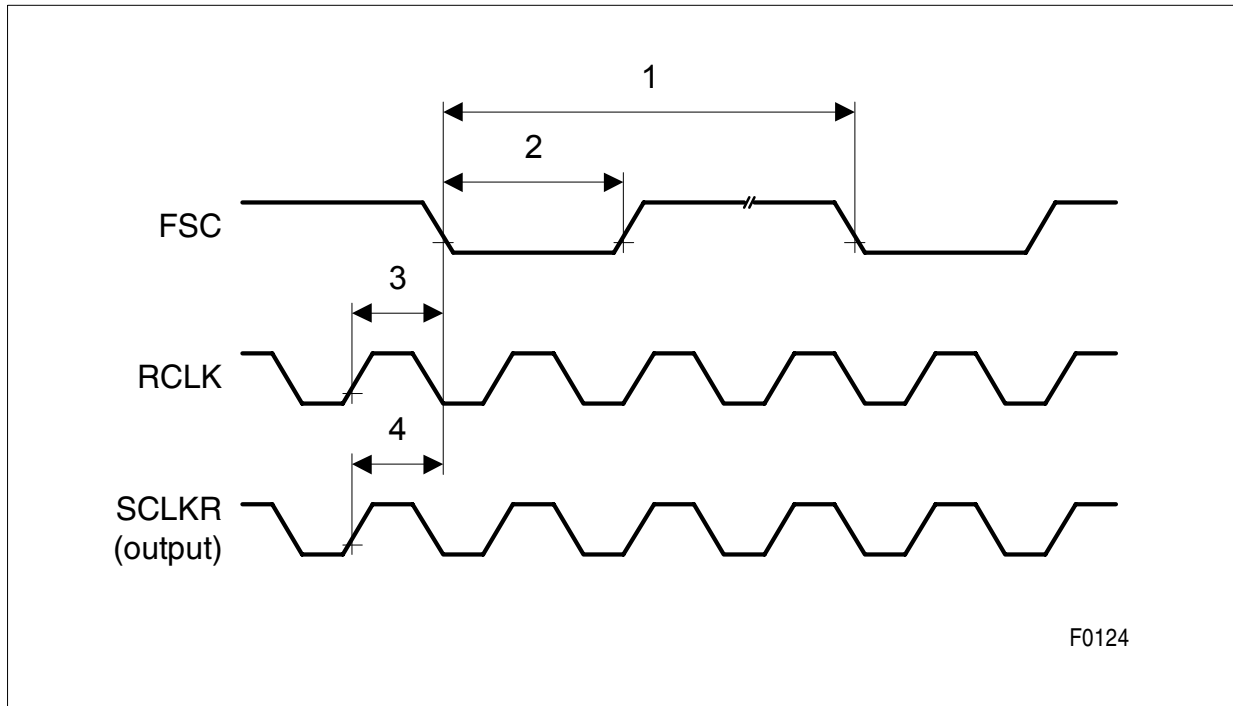

Figure 101 FSC Timing

Table 85 FSC Timing Parameter Values

No.	Parameter	Limit Values			Unit
		min.	typ.	max.	
1	FSC ¹⁾ period		125		μs
2	FSC high/low active time E1		488		ns
2	FSC high/low active time T1/J1		648		ns
3	RCLK to FSC delay		50	80	ns
4	SCLKR to FSC delay		50	80	ns

¹⁾ FSC can be programmed to be active high or active low (only the active low timing diagram is shown here)

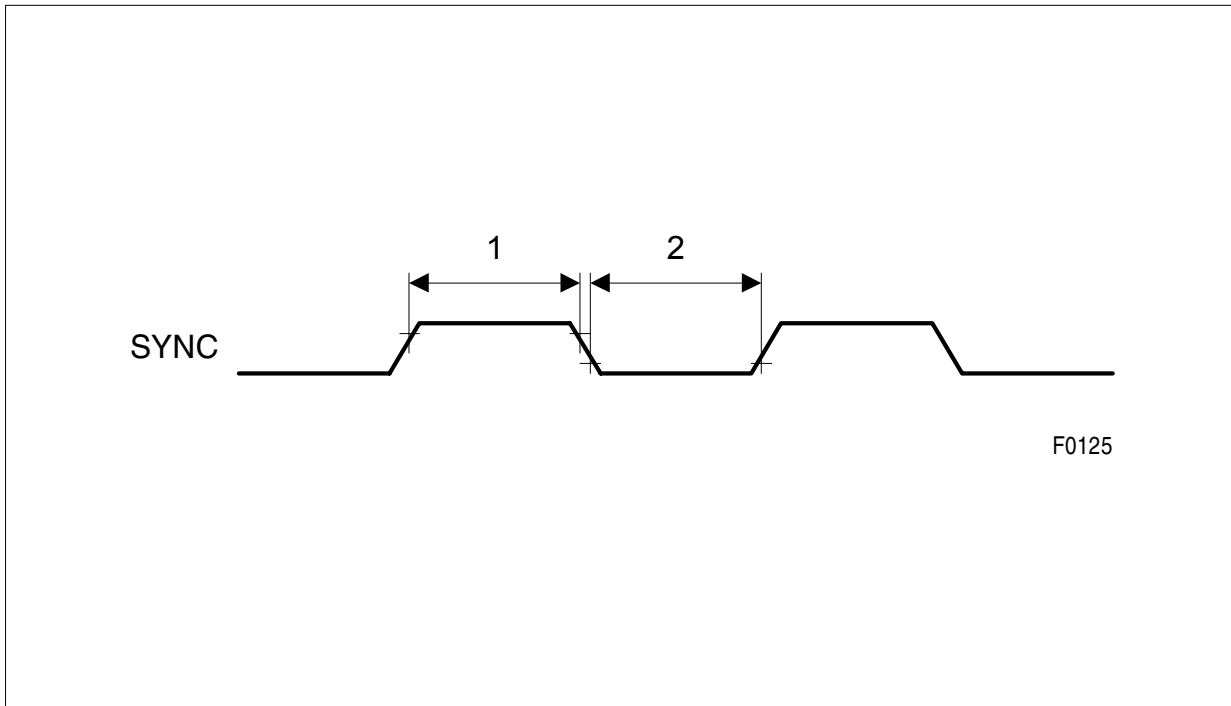

Figure 102 SYNC Timing

Table 86 SYNC Timing Parameter Values

No.	Parameter	Limit Values			Unit
		min.	typ.	max.	
1	SYNC high time	30			%
2	SYNC low time	30			%

11.4.7 Pulse Templates - Transmitter

11.4.7.1 Pulse Template E1

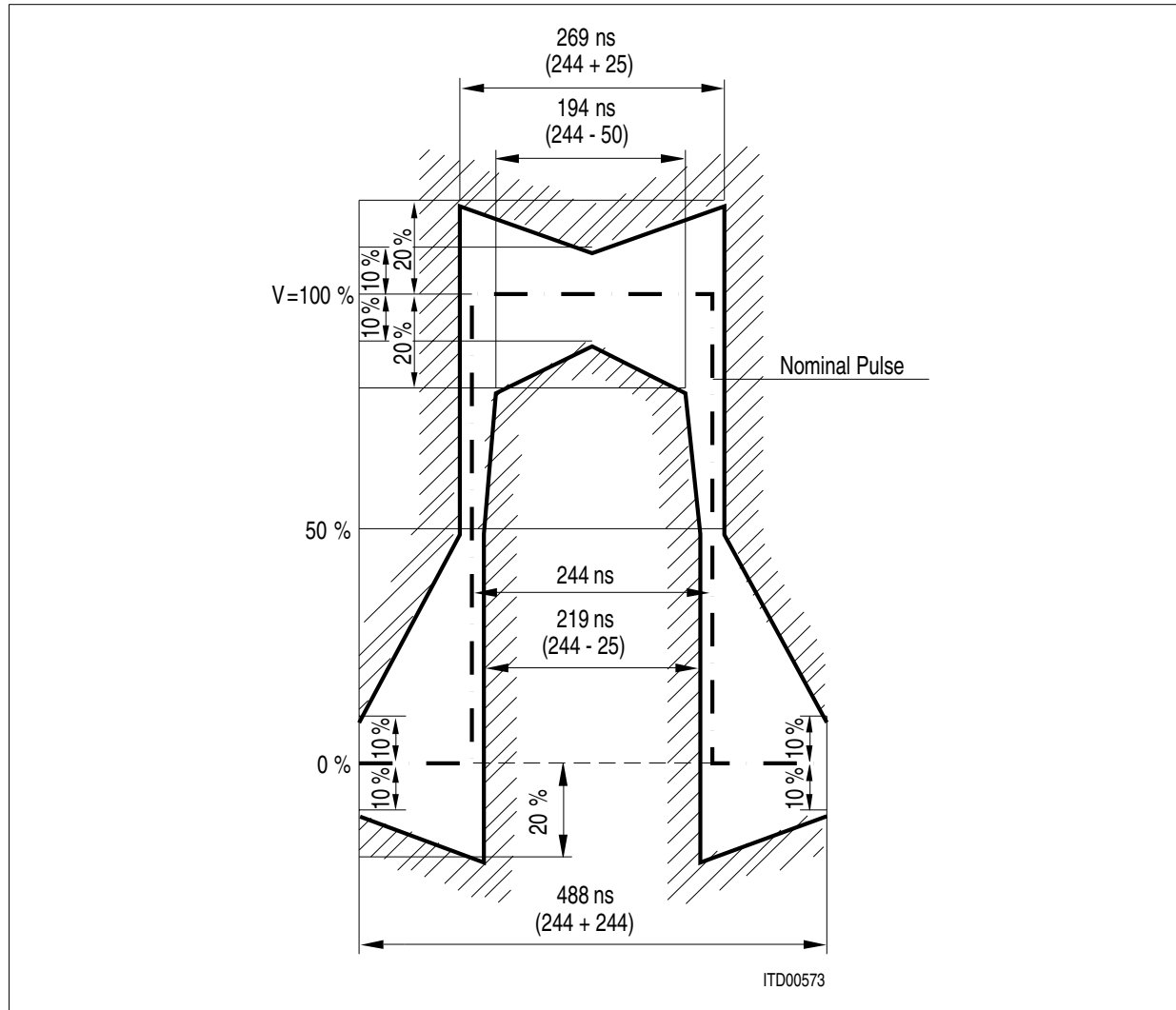

Figure 103 E1 Pulse Shape at Transmitter Output

11.4.7.2 Pulse Template T1

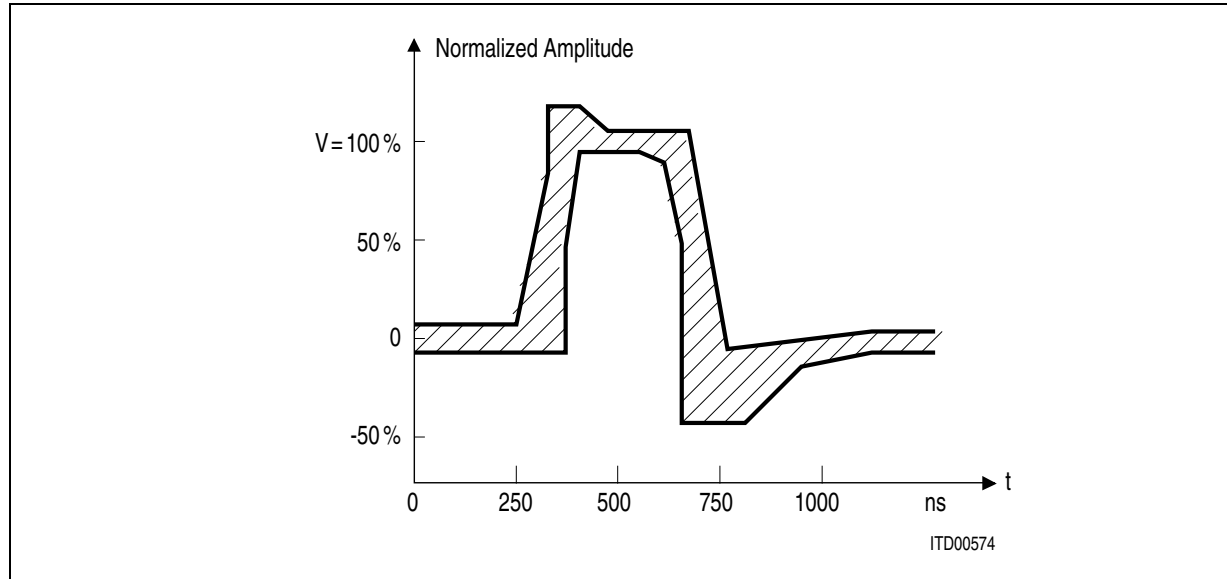

Figure 104 T1 Pulse Shape at the Cross Connect Point

Table 87 T1 Pulse Template at Cross Connect Point (T1.102¹⁾)

Maximum Curve		Minimum Curve	
Time [ns]	Level [%] ²⁾	Time [ns]	Level [%]
0	5	0	-5
250	5	350	-5
325	80	350	50
325	115	400	95
425	115	500	95
500	105	600	90
675	105	650	50
725	-7	650	-45
1100	5	800	-45
1250	5	925	-20
		1100	-5
		1250	-5

¹⁾ requirements of ITU-T G.703 are also fulfilled

²⁾ 100 % value must be in the range of 2.4 V and 3.6 V; tested at 0 ft. and 655 ft. using PIC 22AWG cable characteristics.

11.5 Capacitances

Parameter	Symbol	Limit Values		Unit	Notes
		min.	max.		
Input capacitance ¹⁾	C_{IN}	5	10	pF	
Output capacitance ¹⁾	C_{OUT}	8	15	pF	all except XLx
Output capacitance ¹⁾	C_{OUT}	8	20	pF	XLx

¹⁾ Not tested in production.

11.6 Package Characteristics

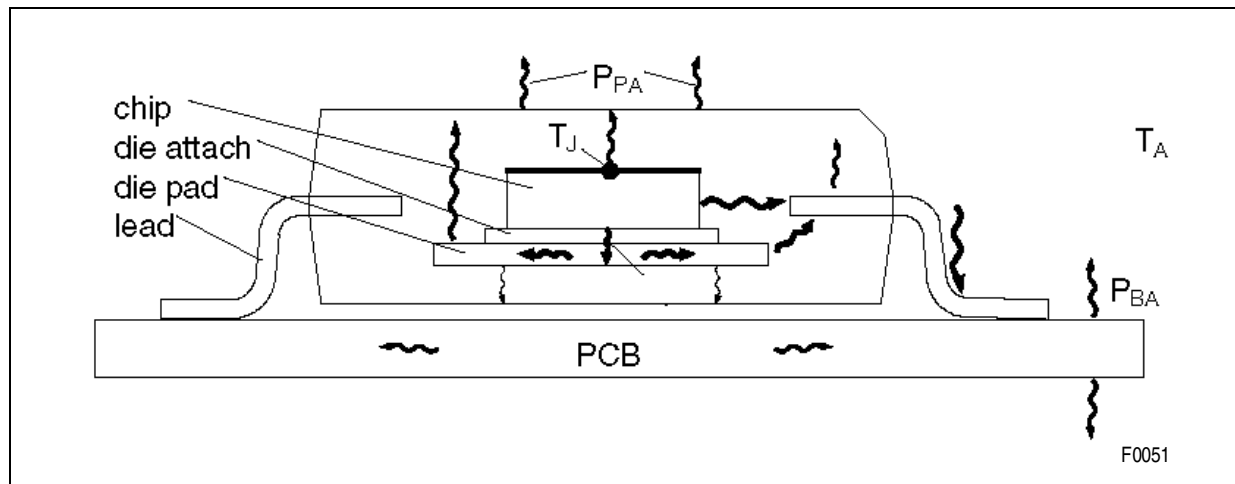

Figure 105 Thermal Behavior of Package

Table 88 Package Characteristic Values

Parameter	Symbol	Limit Values			Unit	Notes
		min.	typ.	max.		
Thermal Resistance MQFP	R_{thjam} ¹⁾		47		K/W	single layer PCB, no convection
	R_{thjc} ²⁾		9		K/W	
Thermal Resistance BGA	R_{thjab} ¹⁾		29		K/W	single layer PCB, natural convection
Junction Temperature	R_j			125	°C	

¹⁾ $R_{thja} = (T_{junction} - T_{ambient})/Power$
Not tested in production.

²⁾ $R_{thjc} = (T_{junction} - T_{case})/Power$
Not tested in production.

11.7 Test Configuration

11.7.1 AC Tests

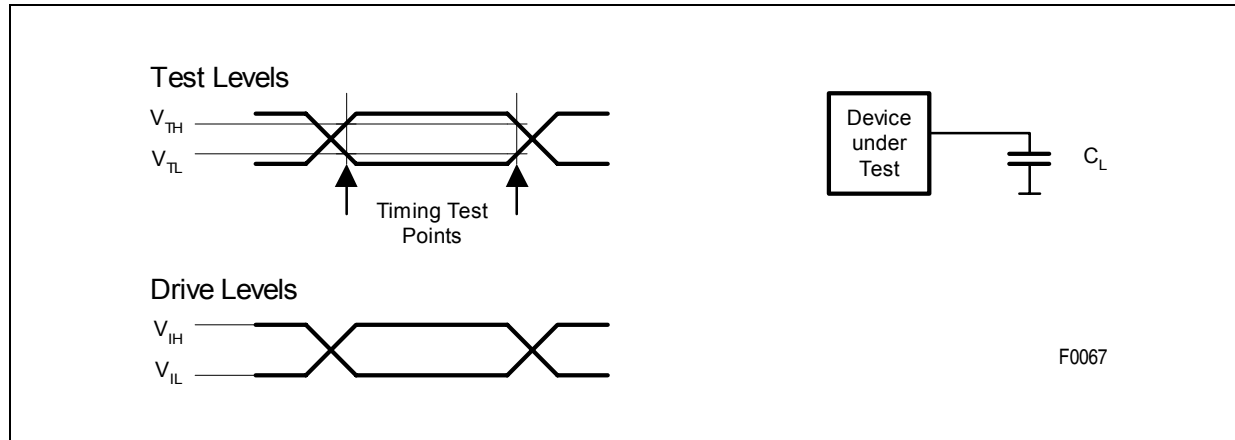

Figure 106 Input/Output Waveforms for AC Testing

Table 89 AC Test Conditions

Parameter	Symbol	Test Values	Unit	Notes
Load Capacitance	C_L	50	pF	
Input Voltage high	V_{IH}	2.4	V	all except RLx
Input Voltage low	V_{IL}	0.4	V	all except RLx
Test Voltage high	V_{TH}	2.0	V	all except XLx
Test Voltage low	V_{TL}	0.8	V	all except XLx

11.7.2 Power Supply Test

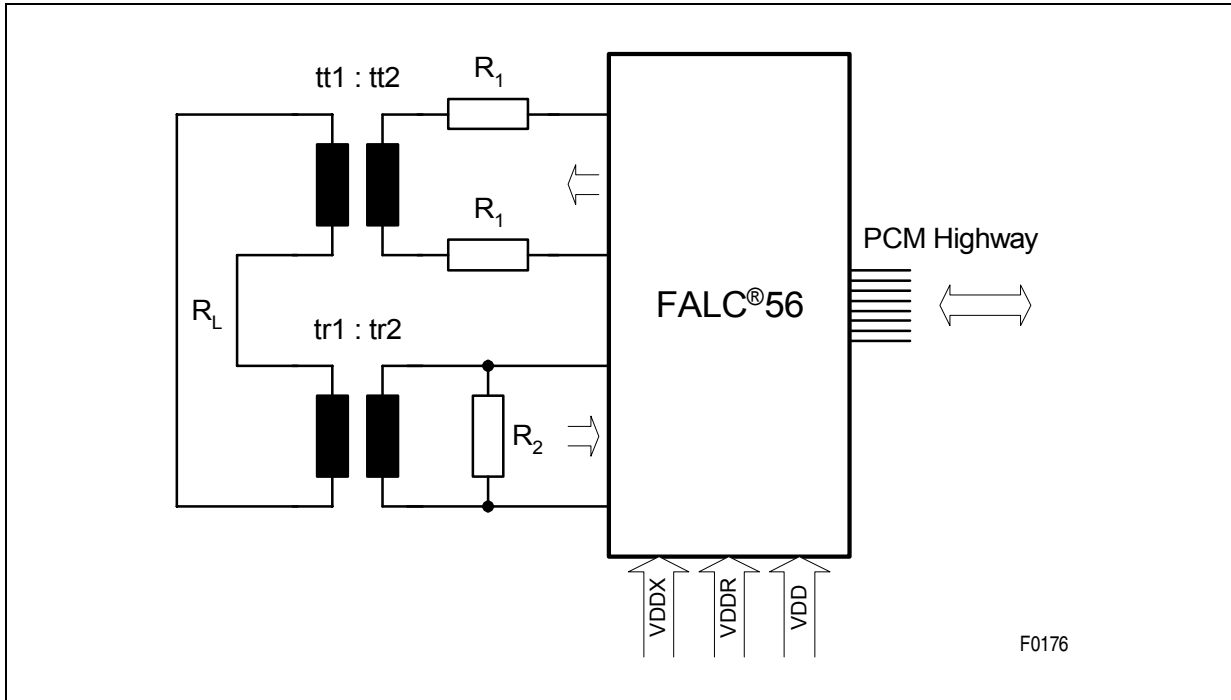

Figure 107 Device Configuration for Power Supply Testing

Table 90 Power Supply Test Conditions E1

Parameter	Symbol	Test Values	Unit	Notes
Load Resistance	R1	7.5	Ω	1%
Termination Resistance	R2	120	Ω	1%
Line Impedance	RL	120	Ω	
Line Length	L	< 0.2	m	
Transformer Ratio Transmit	tt1 : tt2	2.4		
Transformer Ratio Receive	tr1 : tr2	1		
PCM Highway Frequency	SCLKX SCLKR	2.048	MHz	
Test Signal		$2^{15}-1$		PRBS pattern
Pulse Mask Programming	XPM2	00 _H		
	XPM1	03 _H		
	XPM0	BD _H		
Ambient Temperature		85	$^{\circ}\text{C}$	

Electrical Characteristics

Table 91 Power Supply Test Conditions T1/J1

Parameter	Symbol	Test Values	Unit	Notes
Load Resistance	R1	2	Ω	1%
Termination Resistance	R2	100	Ω	1%
Line Impedance	RL	100	Ω	
Line Length	L	< 0.2	m	
Transformer Ratio Transmit	tt1 : tt2	2.4		
Transformer Ratio Receive	tr1 : tr2	1		
PCM Highway Frequency	SCLKX SCLKR	1.544	MHz	
Test Signal		2 ¹⁵ -1		PRBS pattern
Pulse Mask Programming	XPM2	02 _H		
	XPM1	27 _H		
	XPM0	9F _H		
Ambient Temperature		85	°C	

12 Package Outlines

P-MQFP-80-1

(Plastic Metric Quad Flat Package)

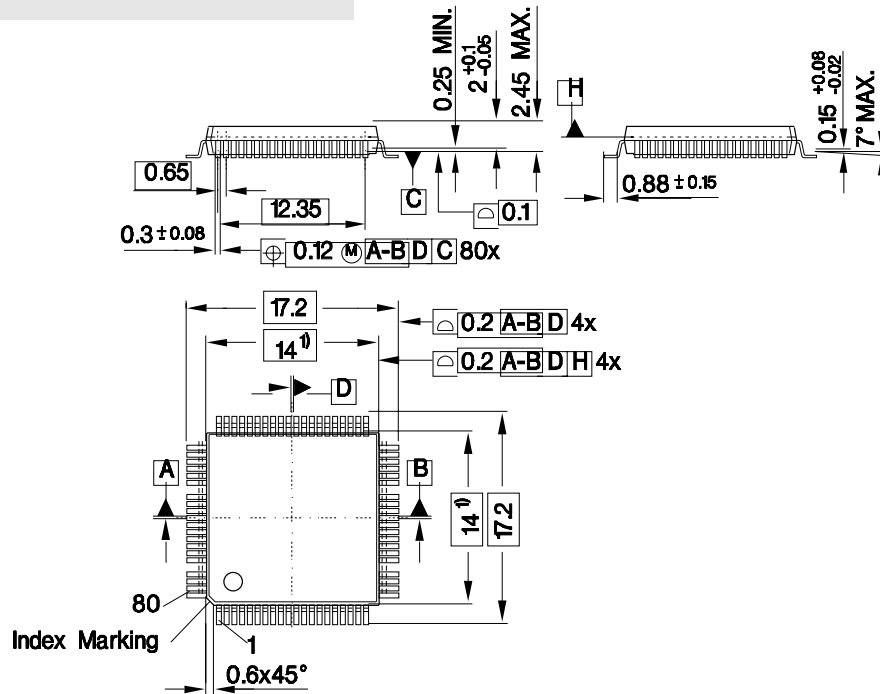

1) Does not include plastic or metal protrusion of 0.25 max. per side

Sorts of Packing

Package outlines for tubes, trays etc. are contained in our Data Book "Package Information".

SMD = Surface Mounted Device

Dimensions in mm

P-LBGA-81-1
(Plastic Ball Grid Array Package)

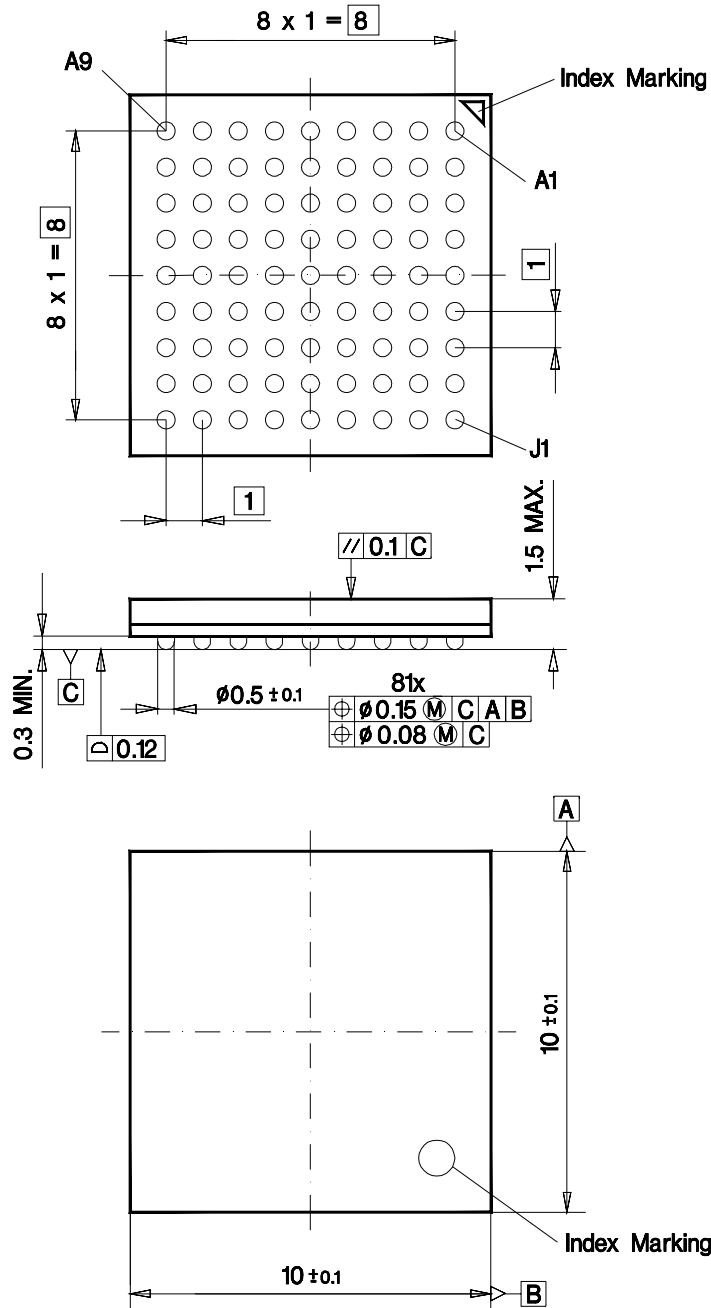

GPA0LB81

Sorts of Packing

Package outlines for tubes, trays etc. are contained in our Data Book "Package Information".

SMD = Surface Mounted Device

Dimensions in mm

13 Appendix

13.1 Protection Circuitry

The design in **Figure 108** shows an example of how to build up a generic E1/T1/J1 platform. The circuit shown has been successfully checked against ITU-T K.20 and K.21 lightning surge tests (basic level).

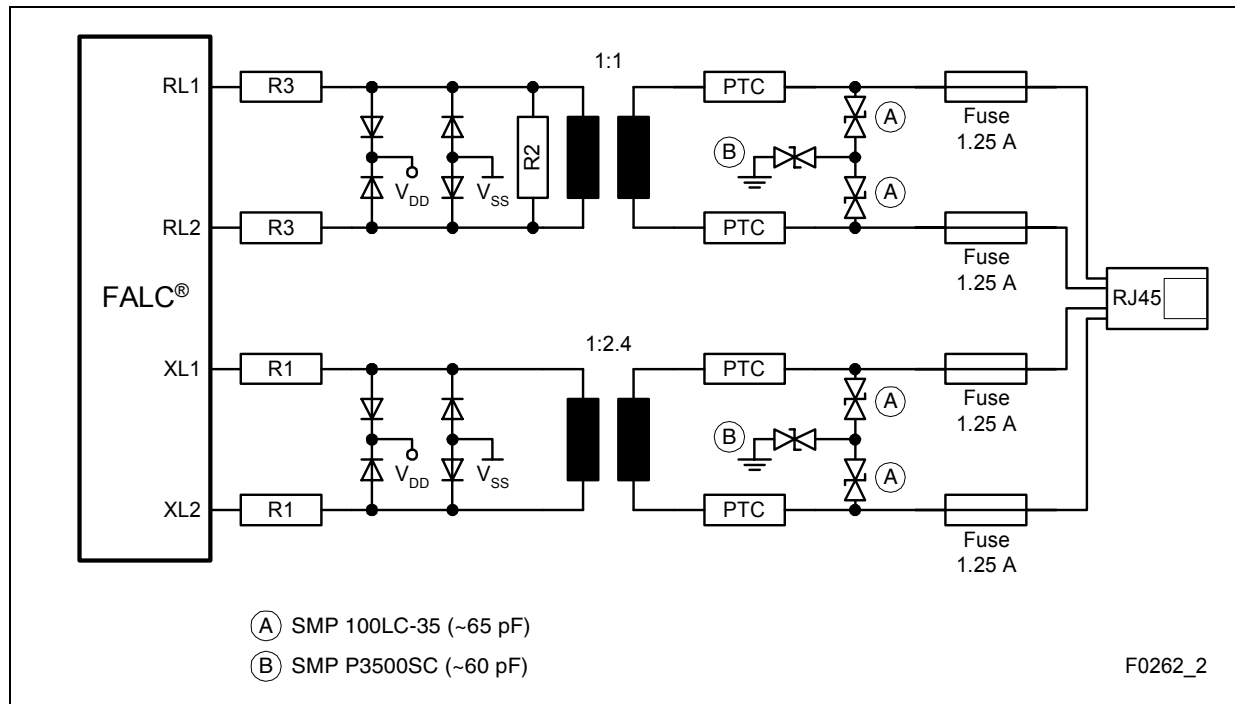

Figure 108 Protection Circuitry Examples

13.2 Application Notes

Several application notes and technical documentation provide additional information. Online access to supporting information is available on the internet page:

<http://www.infineon.com/falc>

On the same page you find as well the

- Boundary Scan File for FALC56 Version 1.2 (BSDL File)

13.3 Software Support

The following software package is provided together with the FALC56 Reference System EASY2256:

- E1 and T1 driver functions supporting different ETSI, AT&T and Telcordia (former: Bellcore) requirements
- IBIS model for FALC56 Version 1.2 (according to ANSI/EIA-656)
- Flexible Master Clock Calculator
- External Line Front End Calculator

To make system design easier, two software tools are available. The first is the "Master Clock Frequency Calculator", which calculates the required register settings depending on the external master clock frequency (MCLK). The second is the "External Line Front End Calculator" which provides an easy method to optimize the external components depending on the selected application type. Calculation results are traced and can be stored in a file or printed out for documentation. The tools run under a Win9x/NT environment.

Screenshots of both programs are shown in **Figure 109** and **Figure 110** below.

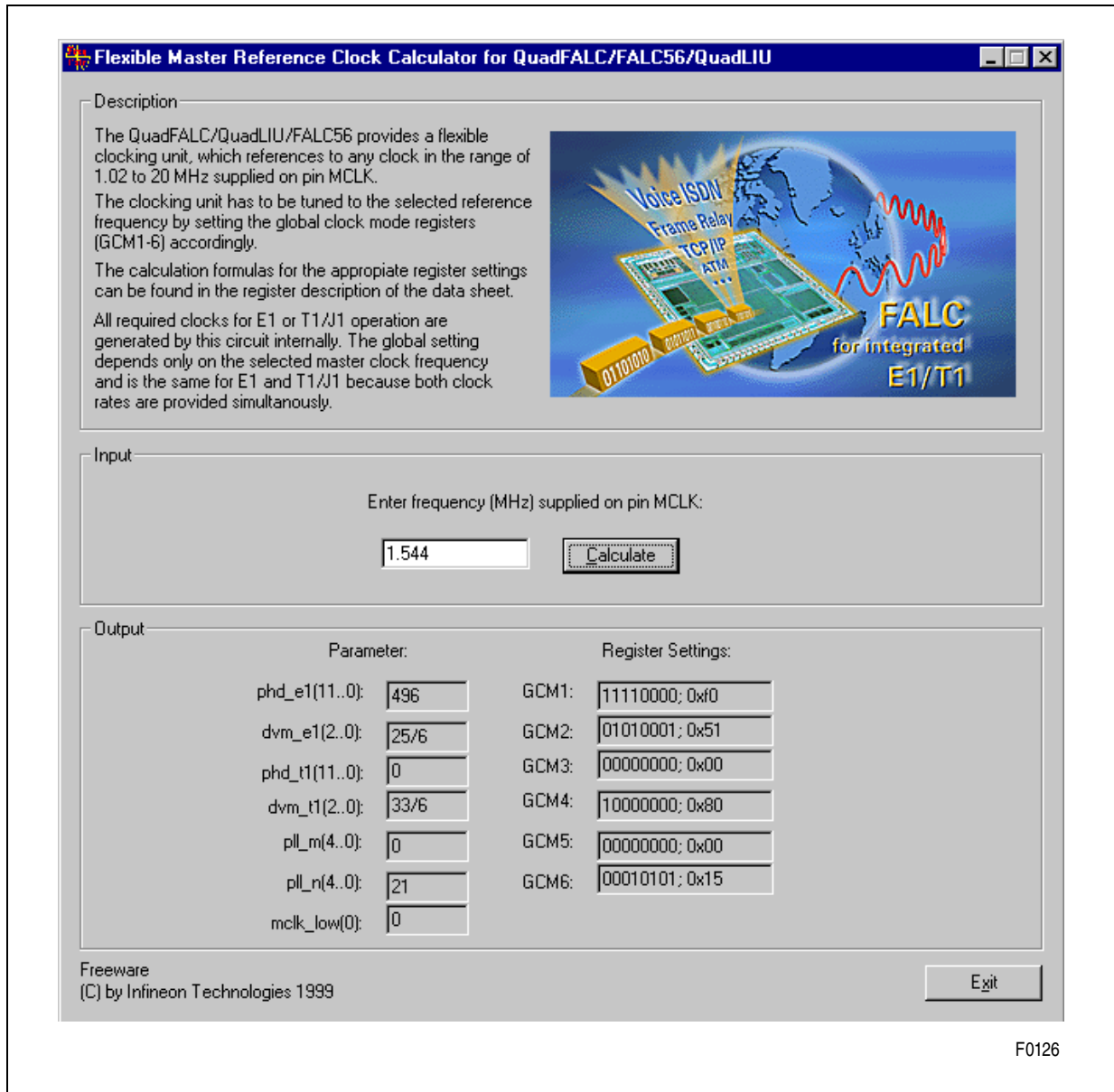

Figure 109 Master Clock Frequency Calculator

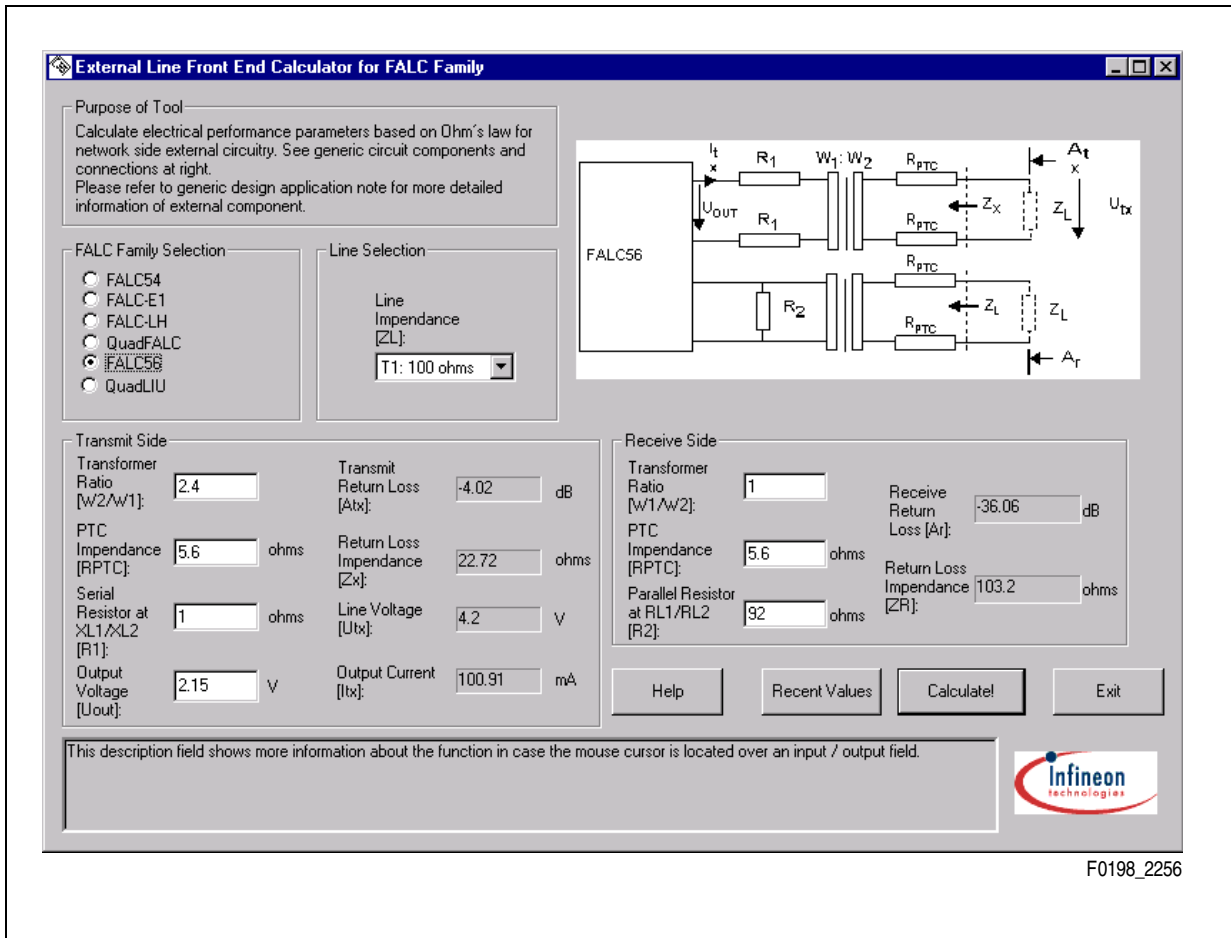

Figure 110 External Line Frontend Calculator

14 Glossary

A/D	Analog to digital
ADC	Analog to digital converter
AIS	Alarm indication signal (blue alarm)
AGC	Automatic gain control
ALOS	Analog loss of signal
AMI	Alternate mark inversion
ANSI	American National Standards Institute
ATM	Asynchronous transfer mode
AUXP	Auxiliary pattern
B8ZS	Line coding to avoid too long strings of consecutive "0"
BER	Bit error rate
BFA	Basic frame alignment
BOM	Bit orientated message
Bellcore	Bell Communications Research
BPV	Bipolar violation
BSN	Backward sequence number
CAS	Channel associated signaling
CAS-BR	Channel associated signaling - bit robbing
CAS-CC	Channel associated signaling - common channel
CCS	Common channel signaling
CMI	coded mark inversion code (also known as 1T2B code)
CR	Command/Response (special bit in PPR)
CRC	Cyclic redundancy check
CSU	Channel service unit
CVC	Code violation counter
DCO	Digitally controlled oscillator
DL	Digital loop
DPLL	Digitally controlled phase locked loop
DS1	Digital signal level 1
EA	Extended address (special bit in PPR)

ESD	Electrostatic discharge
EASY	Evaluation system for FALC products
ESF	Extended superframe (F24) format
EQ	Equalizer
ETSI	European Telecommunication Standards Institute
FALC [®]	Framing and line interface component
FAS	Frame alignment sequence
FCC	US Federal Communication Commission
FCS	Frame check sequence (used in PPR)
FISU	Fill in signaling unit
FPS	Framing pattern sequence
FSN	Forward sequence number
HBM	Human body model for ESD classification
HDB3	High density bipolar of order 3
HDLC	High level data link control
IBIS	I/O buffer information specification (ANSI/EIA-656)
IBL	In band loop (=LLB)
ISDN	Integrated services digital network
ITU	International Telecommunications Group
JATT	Jitter attenuator
JTAG	Joined Test Action Group
LAPD	Link access procedure on D-channel
LBO	Line build out
LCV	Line code violation
LIU	Line interface unit
LFA	Loss of frame alignment
LL	Local loop
LLB	Line loop back (= IBL)
LOS	Loss of signal (red alarm)
LSB	Least significant bit
LSSU	Link status signaling unit
MF	Multiframe

MSB	Most significant bit
MSU	Message signaling unit
NRZ	Non return to zero signal
PDV	Pulse-density violation
PLB	Payload loop back
PLL	Phase locked loop
PMQFP	Plastic metric quad flat pack (device package)
PPR	Periodical performance report
PRBS	Pseudo random binary sequence
PTQFP	Plastic thin metric quad flat pack (device package)
RAI	Remote alarm indication (yellow alarm)
RL	Remote loop
SAPI	Service access point identifier (special octet in PPR)
SF	Superframe
Sidactor	Overvoltage protection device for transmission lines
TAP	Test access port
TEI	Terminal endpoint identifier (special octet in PPR)
UI	Unit interval
ZCS	Zero code suppression

Index

A

Address Bus 29
Address Latch Enable 30
Alarm Simulation 118, 186
Application Notes 481
Applications 22, 24

B

BEC 420
Bit Oriented Message 209
Bit Oriented Messages 137
Bit Robbing 137, 161, 162
Boundary Scan 49, 57, 451, 481
BSN 100, 161
Bus High/Low Enable 31

C

CAS 76, 77, 101, 137, 161, 162, 193
CCBx 363
CCR1 221, 338
CCR2 224, 341
CCR3 271, 391
CCR4 273, 393
CCR5 274, 394
CEC 418
CEC1 300
CEC2 302
CEC3 303
Channel Associated Signaling 76, 77, 101
Channel Translation Mode 131
Chip Select 31
Clear Channel 153, 155, 162
Clock and Data Recovery 61, 120
Clock of DCO-R 36
Clock of DCO-X 37
Clock Synchronization 36
Clocking Unit 59, 60
CMDR 217, 334
CMDR2 269, 389
CMDR3 269, 389

CMDR4 270, 390
CMR1 258, 378
CMR2 259, 379
COEC 421
CRC16 74, 100, 135, 161
CRC-Multiframe 83
CVC 299, 417

D

D4 139, 143
Data Bus 29
Data Bus Width 30
Data Link Access 211
Data Link Bit Receive 42
Data Link Bit Transmit 47
Data Strobe 30
DEC 262, 382
Defect Insertion 118, 186
DLR 42
DLX 47
Doubleframe Format 80

E

EBC 300, 301, 419
Elastic Buffer 70, 97, 129, 157
Error counter 92, 152
ESD 446
ESF 139, 144, 162
ESM 262, 382

F

F12 139, 140
F24 139, 144, 162
F4 139, 142
F72 139, 140, 211
FEC 298, 416
FIFO Structure 53
FISU 74, 100, 135, 161
FMR0 228, 345
FMR1 230, 347
FMR2 232, 349
FMR3 245
FMR4 352

FMR5 354
Fractional E1 Access 257
Fractional T1/J1 Access 377
Frame Aligner 20
Frame Synchronous Pulse 43
FRS0 291, 411
FRS1 294, 413
FRS2 415
FSN 100, 161

G

GCM1 277, 397
GCM2 277, 397
GCM3 278, 398
GCM4 278, 399
GCM5 279, 400
GCM6 279, 400
GCR 261, 381
GIS 55, 321, 437
GPC1 267, 387

H

HDLC 192, 201

I

IBIS Model 481
ICBx 246, 364
IDLE 243, 362
IEEE 1149.1 57
IERR 227, 345
IMRx 227, 344
In-Band Loop 92, 153
Initialization in E1 Mode 188
Initialization in T1/J1 Mode 194
INT 55
Interface Mode 31
Interrupt 31
Interrupt Interface 55
IPC 56, 221, 338
IS 55
ISR0 310, 428
ISR1 312, 430
ISR2 314, 431

ISR3 316, 433
ISR4 317, 434
ISR5 319, 436

J

J1-Features 187
Jitter 66, 96, 125, 155
JTAG 49

L

LCR1 251, 370
LCR2 253, 372
LCR3 253, 372
LIM0 247, 364
LIM1 248, 366
LIM2 250, 369
Line Build-Out 159
Line Coding 62, 121
Line Interface 19, 32, 34, 458
Line Monitoring 63, 123
Local Loop 116, 184
LOOP 233, 351
LOS 449
Loss of Signal 65, 124
LSSU 74, 135

M

Master Clock 36, 59
Microprocessor Interface 21, 52, 453
MODE 219, 336
MODE2 275, 395
MODE3 276, 396
MSU 74, 135
Multifunction Port 40, 44

O

One-Second Timer 37, 92, 152

P

Payload Loop Back 117, 183
P-BGA-81 479
PC1...4 264, 384
PC5 266, 386

PC6 268, 388
PCD 249, 367
PCR 250, 368
Performance Monitoring 85, 150
Periodical Performance Report 162
Power Supply 48
PPR 162, 389, 395
Protection 480
Protection Switching 124
Pseudo-Random Bit Sequence 114, 182
P-TQFP-144-8 478
Pulse Density 153
Pulse Shaper 98, 159
Pulse Template 472, 473

R

RAH1 220, 337
RAH2 220, 337
RAL1 220, 337
RAL2 220, 337
RBC2 323, 439
RBC3 323, 439
RBCH 310, 427
RBCL 310, 427
RBD 289, 409
RC0 238, 357
RC1 239, 359
RDL1 422
RDL2 422
RDL3 423
Read Enable 30
Read/Write Enable 30
Receive Clock 38
Receive Clock Input 33
Receive Data Input 32, 33
Receive Data Out 39
Receive Equalization Network 61, 120
Receive Frame Marker 41
Receive Line Attenuation Indication 61,
120
Receive Line Interface 60, 119
Receive Multiframe Begin 41
Receive Optical Interface 32

Receive Signaling Data 42
Receive Signaling Marker 42
Register Addresses 213, 286, 330, 407
Remote Loop 114, 182
RES 48, 290, 410
Reset 48, 188, 194, 452
RFIFO 289, 409
RFIFO2 329, 445
RFIFO3 329, 445
RFM 41
RFSP 43
RMFB 41
RS1...12 438
RS1...16 322
RSA6S 305
RSAx 304
RSIG 42
RSIGM 42
RSIS 308, 425
RSIS2 325, 440
RSIS3 327, 443
RSP 296
RSP1 306, 423
RSP2 306, 423
RSW 295
RTR1...4 225
RTRx 342

S

Sa bit Access 208
SAPI 395
SCLKX 43
SF 143
SIC1 254, 373
SIC2 255, 374
SIC3 256, 376
Signaling Controller 21, 73, 99, 134, 160
Single Channel Loop Back 117, 185
SIS 307, 424
SIS2 323, 439
SIS3 326, 442
SLC96 139, 146
Software 481

SS7 74, 100, 135, 161, 219, 336
SU 74, 100, 135, 161
Supply voltage 446
Synchronous Pulse Receive 40
Synchronous Pulse Transmit 45
SYPX 45
System Clock Receive 39
System Clock Transmit 43
System Interface 39, 43, 102, 165, 460

T

TCLK 46
Test Access Port 57
Test Clock 49
Test Data Input 49
Test Data Output 49
Test Mode Select 49
Test Reset 49
Time-Slot Assigner 113, 180
TPC0 285, 406
Transmit Clock 46, 47
Transmit Data In 43
Transmit Data Output 34, 35
Transmit Frame Marker 35
Transmit Line Interface 95, 154
Transmit Line Monitor 98, 160
Transmit Line Tristate 47
Transmit Multiframe Begin 46
Transmit Multiframe Synchronization 45
Transmit Optical Interface 34
Transmit Signaling Data 45
Transmit Signaling Marker 46
Transparent Mode 204
TSBS1 282, 403
TSBS2 283, 404
TSBS3 283, 404
TSEO 281, 402
TSS2 284, 405
TSS3 284, 405
TSWM 242
TTR1...4 226
TTRx 343

U

Unused Pins 49

V

VIS 56
VSTR 290, 410

W

WID 329, 445
Write Enable 30

X

XC0 236, 355
XC1 237, 356
XCLK 47
XDI 43
XDLx 362
XFIFO 217, 334
XFIFO2 281, 402
XFIFO3 281, 402
XLT 47
XMFB 46
XMFS 45
XPMx 241, 361
XS1...12 383
XS1...16 263
XSAx 244
XSIG 45
XSIGM 46
XSP 235
XSW 234
XTS16RA 221