

# Dual-Battery Charge Controller

## FEATURES

- Quick and Easy Testing for Production.
- Sequential Charging Control of Two NiMH/NiCd Battery Packs.
- Reliable Sequential Fast Charge Control of Dual NiMH and/or NiCd Battery Packs, even with a Fluctuating Charging Current.
- Fast Charge Termination by:  $\Delta T / \Delta t$ ,  $-\Delta V$ ,  $0\Delta V$ , Safety Timer, Maximum Temperature, Maximum Voltage.
- Safety Timer and  $\Delta T / \Delta t$  Detection Slope Linearly Adjustable.
- Battery Voltage Protection Range Selectable.
- Mode of Battery Temperature Protection Selectable.
- Protection against Battery Voltage and Battery Temperature Faults.
- Selectable LED Display Mode for Battery Status.
- Five Pulsed Trickle Charge Modes.
- Discharge-before-Charge Function Available to Eliminate Memory Effect.
- 20-pin DIP or SO Packages.

## APPLICATIONS

Dual-Battery Fast Chargers for:

- Mobile Phones.
- Notebook and Laptop Personal Computers.
- Portable Power Tools and Toys.
- Portable Communication Equipments.
- Portable Video & Stereo Equipments.

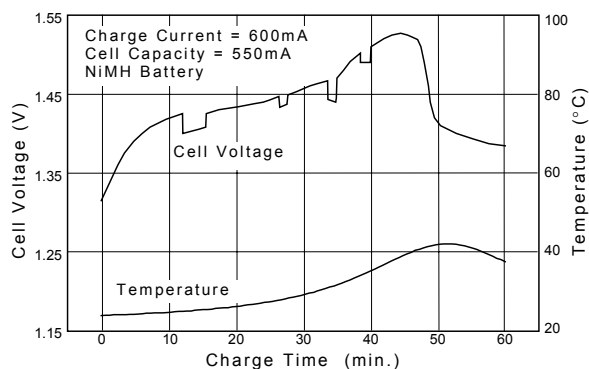

**Fig. 1 Battery Charging Characteristics Resulted from an AIC1782-Controlled Charger with a Fluctuating Charging Current**

## DESCRIPTION

The AIC1782 fast charge controller is designed for intelligent sequential charging of dual NiMH and NiCd batteries without the risk of malfunction. After powered on, the AIC1782 charging sequence gives priority to battery pack A, represented by input signals of ATS and ABV pins, over battery pack B, represented by BTS and BBV pin signals. The AIC1782 automatically switches charging current to charge the standby battery pack after the battery pack being charged finishes its charging or encounters a fault condition.  $-\Delta V$  ( $-0.25\%$ ) detection,  $0\Delta V$  (peak voltage timer) detection, and  $\Delta T / \Delta t$  detection are the primary methods employed by the AIC1782 to terminate fast charge. The fast charge can also be cut off by maximum battery voltage and maximum battery temperature detection along with the safety timer to prevent charging under fault conditions of the charging system or the battery itself.

Both  $\Delta T / \Delta t$  and  $-\Delta V$  detection methods have been proved powerful in terminating fast charging for NiMH and NiCd batteries. The AIC1782 utilizes the combination of these two methods to achieve reliable decision of ending fast charge and prevent misaction caused by using  $-\Delta V$  detection alone under certain conditions. Fig. 1 shows an example of charging curve of a battery charged by a fluctuating current from a NiMH battery charger which uses the AIC1782 controller IC to achieve optimal charging. The  $\Delta T / \Delta t$  or  $-\Delta V$  detection circuitry may be disabled independently for different applications, such as system-integrated chargers, chargers with varying charge current, or battery packs lack of temperature sensing thermistor.

The safety timer period, mode of battery temperature protection, battery voltage protection range, pulsed trickle charge duty, and LED display mode are all adjustable or selectable. Discharge-before-charge function is included to get

rid of memory effect of NiCd batteries without the risk of overdischarging. Test mode is provided for charger manufacturers to dramatically reduce production test time.

## TYPICAL APPLICATION CIRCUIT

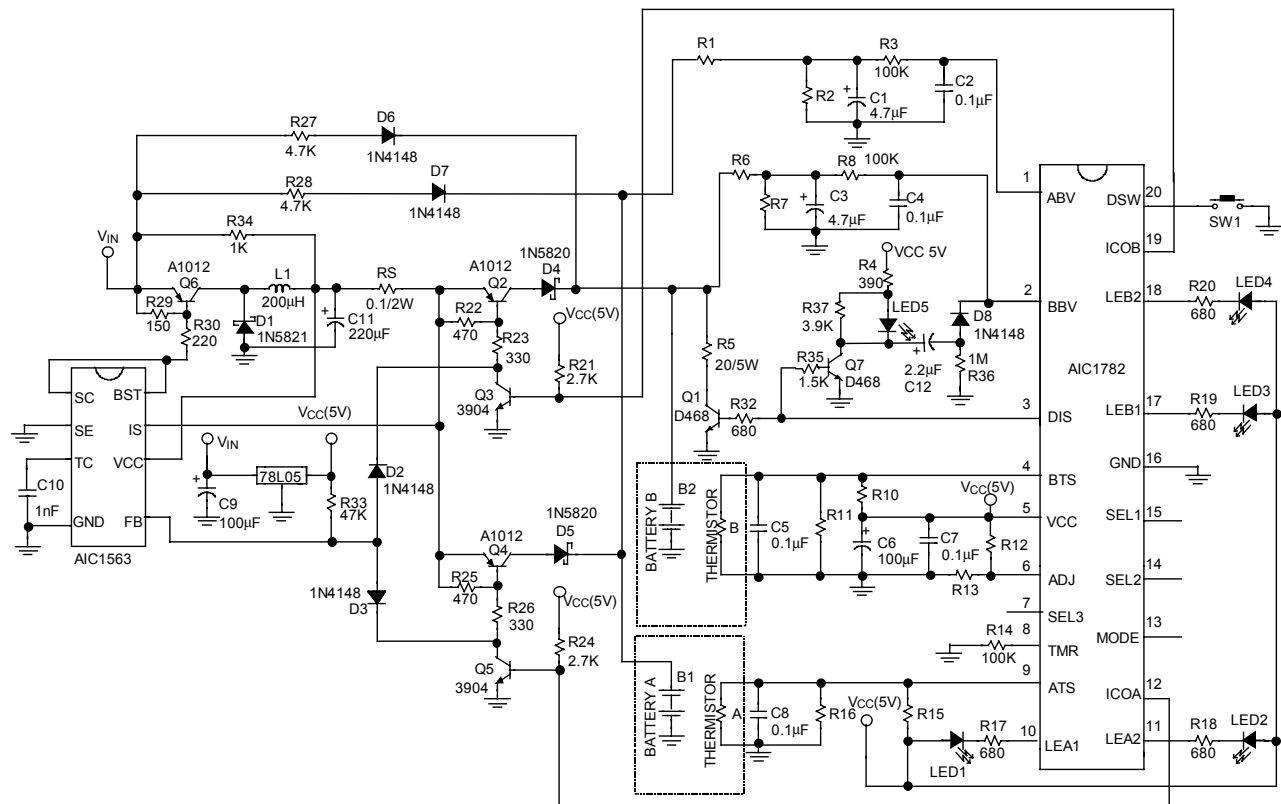

Battery Charger for Dual NiMH and NiCd Battery

## ORDERING INFORMATION

AIC1782 XX

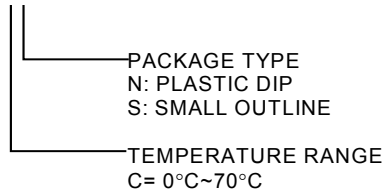

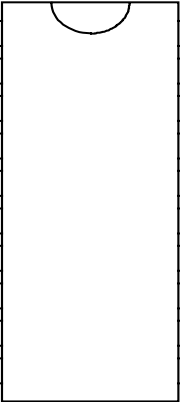
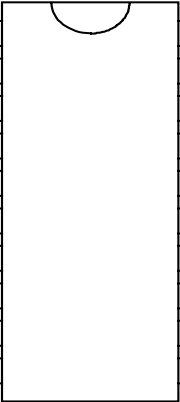
ORDER NUMBER	PIN CONFIGURATION
AIC1782 CN (PLASTIC DIP)	
AIC1782 CS (PLASTIC SO)	

## ABSOLUTE MAXIMUM RATINGS

Supply Voltage .....	5.5V
DC Voltage Applied on any Pin .....	5.5V
Sink Current of ICOA Pin, LEA1 and LEA2 Pins .....	20mA
Sink Current of ICOB Pin, LEB1 and LEB2 Pins .....	20mA
Operating Temperature Range .....	0°C~ 70°C
Storage Temperature Range .....	-65°C~ 150°C

## TEST CIRCUIT

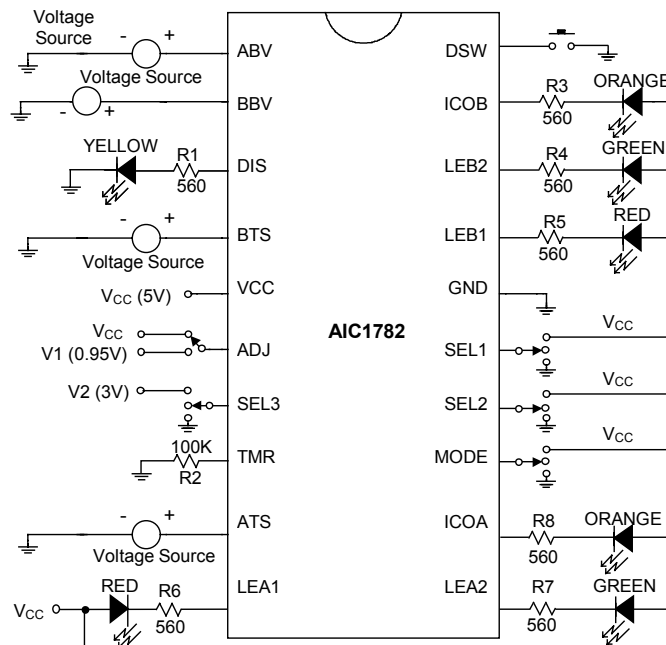

**ELECTRICAL CHARACTERISTICS** ( $T_a=25^\circ\text{C}$ ,  $V_{CC}=5\text{V}$ , unless otherwise specified.)

PARAMETER	TEST CONDITIONS	SYMBOL	MIN.	TYP.	MAX.	UNIT
Supply Voltage		$V_{CC}$	4.5	5	5.5	V
Supply Current		$I_{CC}$		1.1		mA
Voltage Protection Limit	Battery Low Before Initial Timer	$V_{ABV}$	0.11	0.16	0.21	V
	After Initial Timer (SEL3>3V)	$V_{BBV}$	0.63	0.69	0.75	
	(SEL3<2V)		1.1	1.2	1.3	
	Battery High (SEL3>3V)		2.6	2.7	2.8	
	(SEL3<2V)		1.9	2.0	2.1	
Temperature Sense Limit	Temperature High	$V_{ATS}$	1.35	1.45	1.55	V
	Temperature Low	$V_{BTS}$	3.5	3.6	3.7	
Output impedance of DIS Pin		$Z_{DIS}$		140	250	$\Omega$
Output Impedance	LEA1, LEA2, LEB1, LEB2, ICOA, ICOB pins ON			25	50	$\Omega$
	OFF		1			M $\Omega$
Source Current Capability	SEL3 pin	$I_{SEL3}$		5.5		$\mu\text{A}$
	DSW pin	$I_{DSW}$		16		$\mu\text{A}$
Input Impedance	MODE, SEL1, SEL2 pins			300		K $\Omega$
	ABV, BBV, ATS, BTS, ADJ pins		1			M $\Omega$
Recommended External Resistor of TMR pin		$R_{TM}$ $R$	2	100	1000	K $\Omega$
– $\Delta V$ detection level w.r.t.* Peak Value				-0.25		%

\*: with respected to

**TYPICAL PERFORMANCE CHARACTERISTICS** (Ta=25°C, R2=100KΩ, VCC=5V, refer to Test Circuit)

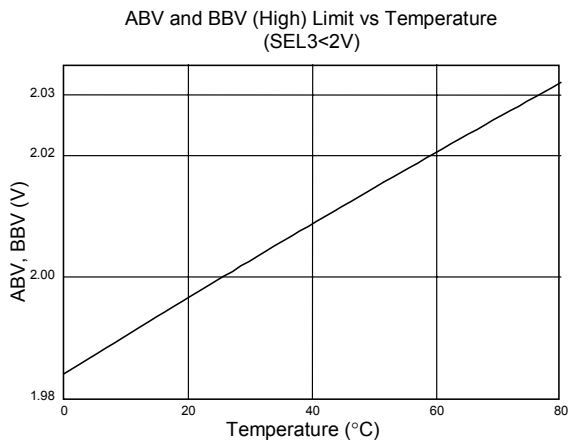
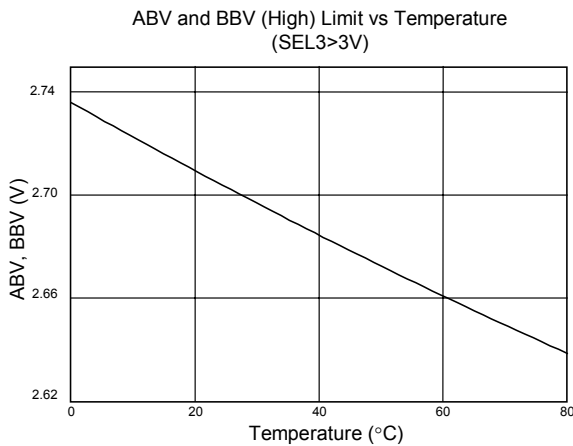
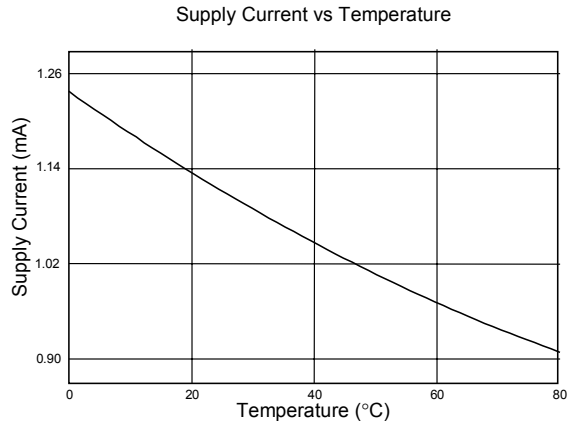
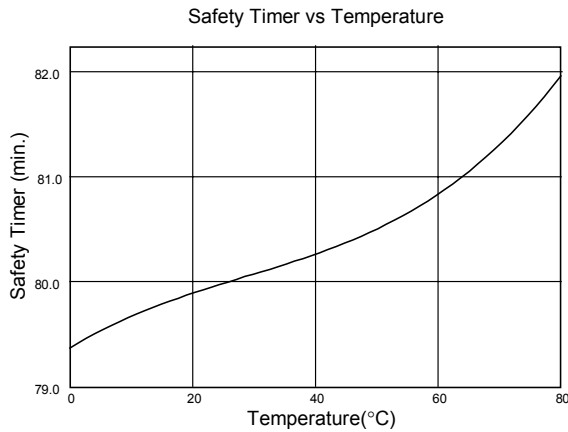
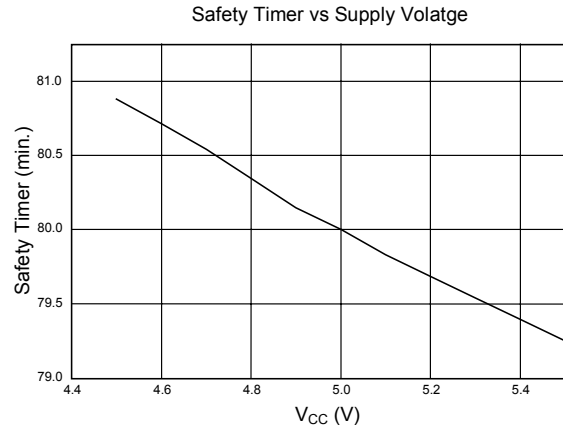
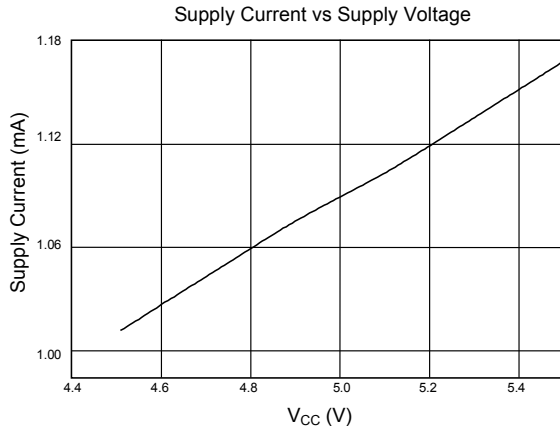

**TYPICAL PERFORMANCE CHARACTERISTICS (Continued)**

ABV and BBV (Low) Limit vs Temperature  
(Before Initial Timer)

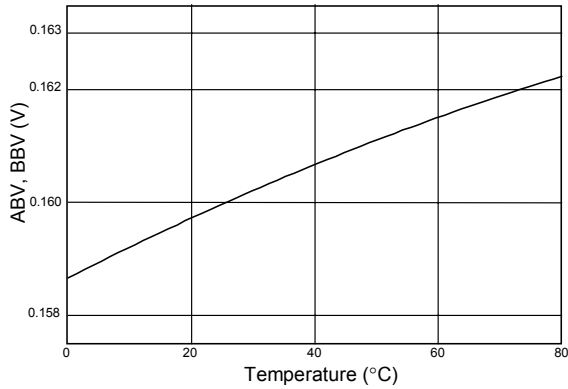

Output Impedance vs Temperature  
(LEA's, LEB's, ICO's pins)

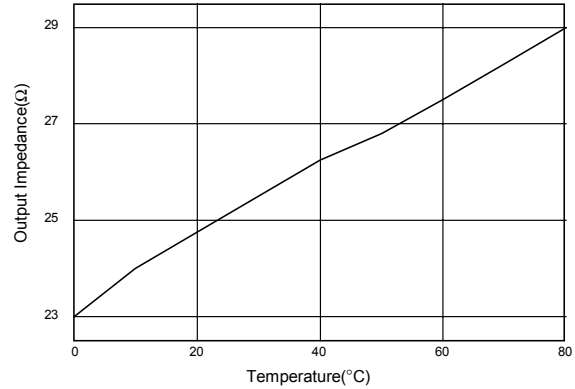

ABV and BBV (Low) limits vs Temperature  
(SEL3<2V, After Initial Timer)

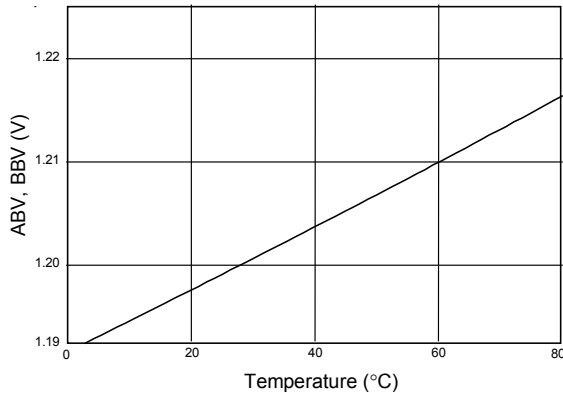

ABV and BBV (Low) limits vs Temperature  
(SEL3>3V, After Initial Timer)

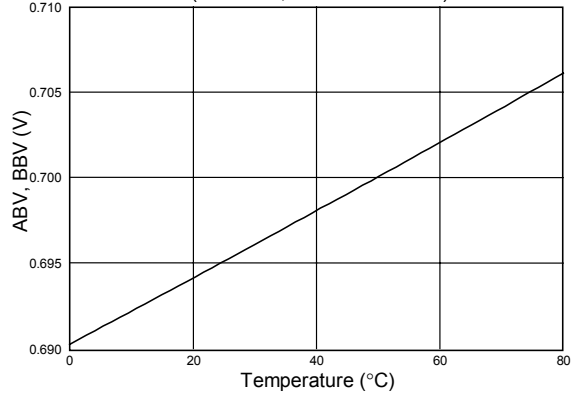

ATS and BTS (High) Limit vs Temperature

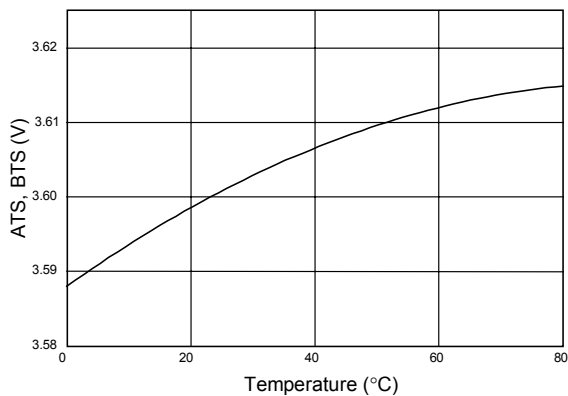

ATS and BTS (Low) Limit vs Temperature

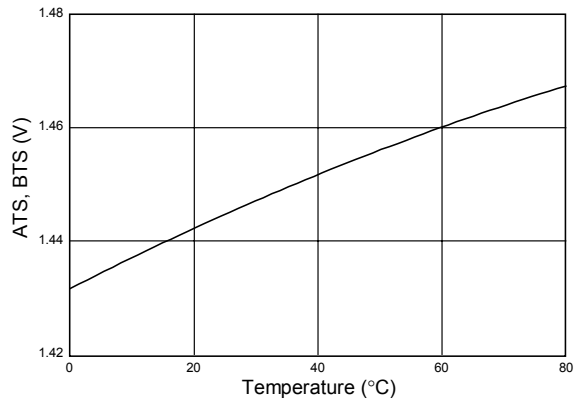

## ■ BLOCK DIAGRAM

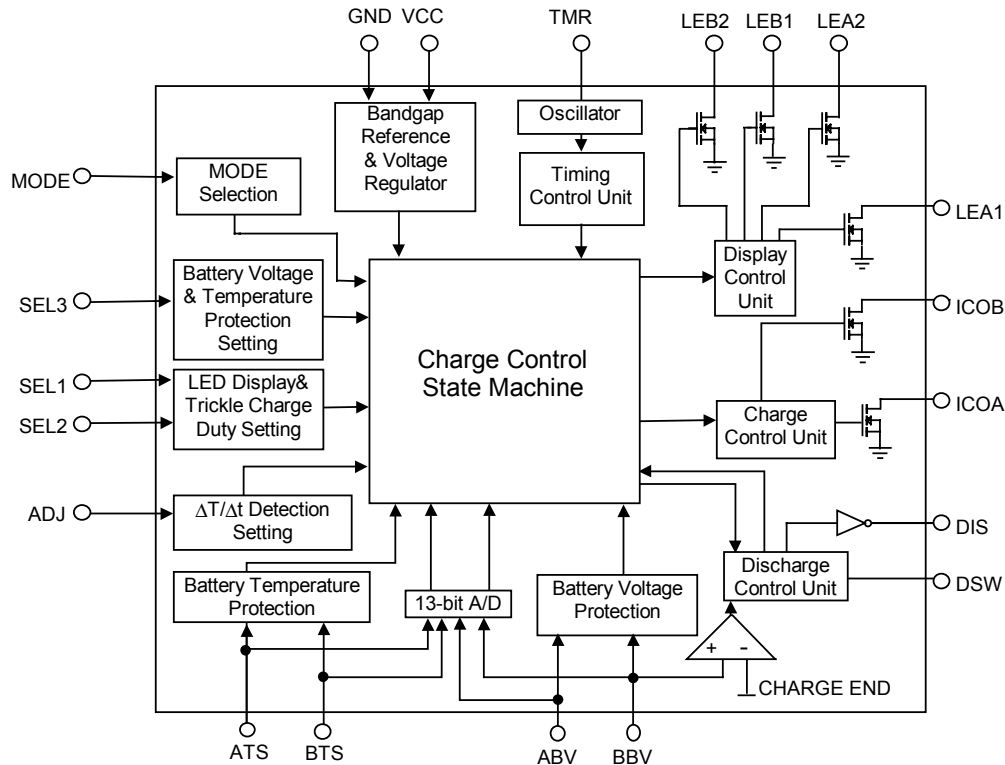

## ■ PIN DESCRIPTIONS

**PIN 1: ABV** - Divided battery voltage input to sense the battery voltage of pack A.

**PIN 2: BBV** - Divided battery voltage input to sense the battery voltage of pack B.

**PIN 3: DIS** - Push-pull output, used to control an external transistor to discharge the battery of pack B. DIS is active high when function of discharge is enabled.

**PIN 4: BTS** - The battery cell temperature of pack B is represented as a voltage input to the AIC1782 at this pin. The acceptable voltage

range of BTS pin is  $0.29 V_{CC}$  to  $0.72 V_{CC}$ .

**PIN 5: VCC** - Power supply input at  $5V \pm 10\%$ .

**PIN 6: ADJ** - For adjusting the slope of  $\Delta T / \Delta t$ . Acceptable voltage range for this pin is approximately 0.28V to 3.8V. If voltage higher than  $V_{CC} - 0.3V$ , function of  $\Delta T / \Delta t$  detection is disabled.

**PIN 7: SEL3** - Determining the acceptable voltage range of ABV and BBV pins and mode of temperature protection function.

- PIN 8: TMR - Determining the period of safety timer with an external resistor connected to GND.
- PIN 9: ATS - The battery cell temperature of pack A is represented as a voltage input to the AIC1782 at this pin. the acceptable voltage range of ATS is  $0.29 V_{CC}$  to  $0.72 V_{CC}$ .
- PIN 10: LEA1 &  
PIN 11: LEA2 - Open-drained outputs used to indicate the charging status of the battery pack A.
- PIN 12: ICOA - Open-drained output, used to control the charging current of the battery pack A.
- PIN 13: MODE - Determining the mode of operation for the AIC1782.
- PIN 14: SEL2 &
- PIN 15: SEL1 - Tri-level inputs, that jointly control the LED display mode and the duty of trickle charge after the completion of fast charge.
- PIN 16: GND - Power ground.
- PIN 17: LEB1 &  
PIN 18: LEB2 - Open-drained outputs used to indicate the charging status of battery pack B
- PIN 19: ICOB - Open-drained output, used to control the charging current of the battery pack B.
- PIN 20: DSW - Controlling the function of discharge-before-charge of the battery pack B. (See discharge-before-charge subsection in application informations).

## ■ APPLICATION INFORMATIONS

### ● THE AIC1782 OPERATION

#### Power-on and Battery Prequalifying

The AIC1782 is a sequential charger, initiating a charge action on either battery pack A or B. When power is first applied to the AIC1782, all internal digital circuit of the AIC1782 are reset by the internal power-on-reset circuitry, the output of LED's (depending on the setting of SEL1 and SEL2 pins) flash 3 times to indicate the initiation of power-on. If both battery pack A and B are present when  $V_{CC}$  is applied to the AIC1782, the charge action begins with battery pack A if conditions are acceptable.

Condition of battery pack A is examined through the ATS and ABV pins, while battery pack B is examined through the BTS and BBV pins. The

acceptable limits of ABV and BBV are determined by the input voltage of SEL3 pin and the acceptable temperature sense voltage window for ATS and BTS are  $0.29 V_{CC}$  to  $0.72 V_{CC}$ .

The AIC1782 controls the initiation of a charge action and checks for acceptable battery voltage and temperature prior to fast charging. If the voltage of ABV or BBV fail to fall within the predetermined acceptable limits, the corresponding battery pack enters a charging-suspending mode. If the voltage of ATS or BTS is outside the  $0.29 V_{CC}$  to  $0.72 V_{CC}$  window, action to AIC1782 is determined by the input voltage of SEL3 pin.

#### Discharge-Before-Charge



The AIC1782 provides the function of discharge-before-charge to precondition NiCd batteries which suffer from memory effect. This function can only be activated for pack B after the prequalification of battery voltage and temperature, yet before the charge completion is registered for fast charge cycle of pack B.

To trigger this function, DSW pin has to be biased to GND over 0.18 second. After discharge begins, LEB1 and LEB2 pins are both OFF, ICOB pin is ON, and DIS pin goes high to activate an external circuit to discharge the battery pack B until the voltage of BBV pin fall below 0.9V (or 0.69V, depending on the input voltage of SEL3 pin) or DSW pin is biased to GND for over 0.18 second again. The application circuit is included in TYPICAL APPLICATION CIRCUIT.

### **Fast Charge**

After the battery passes fault checks, charge begins on either of the batteries, the other battery remains in a waiting state until the first battery terminates fast charge. The AIC1782 will automatically switch to fast charge the second battery. The battery pack A has the priority over battery pack B only when power is first applied to the AIC1782. When fast charging begins, the initial and safety timer of the AIC1782 start counting. Functions of  $-\Delta V$  detection, Peak voltage timer,  $\Delta T / \Delta t$  detection, and maximum battery voltage are, however, disabled temporarily until the initial timer period in the initial stage of a charge cycle elapses. The initial timer period is equal to 1/80 of safety timer.

Since the low limit of acceptable ABV or BBV voltage are only about 0.16V during the initial timer period, even deeply discharged batteries can easily qualify to be fast charged subsequently.

In the course of fast charge, the AIC1782 constantly monitors the battery voltage and temperature through ABV (or BBV) and ATS (or BTS) pins. The fast charge process is registered complete when any one of the following situations is encountered, which are explained below:

- Negative delta voltage ( $-\Delta V$ ).
- Peak voltage timer ( $0\Delta V$ ).
- Delta temperature/ delta time ( $\Delta T / \Delta t$ ).
- Maximum charge time.
- Maximum battery voltage.
- Maximum battery temperature.

### **$-\Delta V$ Cutoff**

The AIC1782 makes a voltage sampling at ABV (or BBV) pin every 4 seconds when safety timer period is set equal to 80 minutes. If a negative delta voltage of 0.25% compared to its peak value is detected at ABV (or BBV) pin, the fast charge cycle is terminated.

### **$0\Delta V$ Cutoff**

If the battery voltage stays at its peak value or decreases very slowly for the duration determined by the peak voltage timer, which is in turn equal 3.7% of safety timer, the fast charge action is terminated.

### **$\Delta T / \Delta t$ Cutoff**

The  $\Delta T / \Delta t$  detection of the AIC1782 is performed by sensing the decrease of ATS (or BTS) pin voltage in a specific timer interval dictated by the safety timer. The fast charging terminates when the decrease of ATS (or BTS) pin voltage in 56 seconds exceeds the predetermined value set by ADJ pin input. This time interval of 56 seconds is based on the assumption that voltage of ATS (or BTS) pin is sampled once for every 8 seconds, which is also determined by safety timer.

Functioning of  $-\Delta V$  detection and peak voltage timer ( $0\Delta V$ ) can be disabled if the MODE pin is biased to GND. Functioning of  $\Delta T / \Delta t$  detection can be disabled if the voltage of ADJ pin is higher than  $V_{CC} - 0.3V$ .

#### Maximum Safety Timer Cutoff

The maximum fast charge period is determined by the safety timer, which is set by a resistor connected from TMR pin to GND. Safety timer,  $-\Delta V$  sampling rate, and  $\Delta T / \Delta t$  sampling rate will be longer if the resistor value is larger. When the value of the resistor is  $100K\Omega$ , the safety timer period equals 80 minutes. This can be verified by biasing MODE pin to  $V_{CC}$  and the measured frequency on DSW pin should be around 32.8 KHz. After the safety timer period is finished, the fast charge action is terminated.

#### Maximum Voltage and Temperature Cutoff

The AIC1782 guards against the maximum limits for battery voltage and temperature during fast charging. If either of these limits is exceeded, fast charge action is terminated.

#### Trickle Charge

There are five different selectable duty cycles for trickle charge after the fast charge to prevent the loss of charge due to battery self-discharging. The setting of SEL1 and SEL2 pins controls the duty cycle. This function can only be activated on the following three situation:

- Battery pack A is charge full and battery pack B is abnormal.
- Battery pack B is charge full and battery pack A is abnormal.
- Battery pack A and B are both charge full.

#### ● DESIGN GUIDE

##### ABV/BBV Range and Temperature Protection

The acceptable battery voltage range of ABV and BBV pins and mode of temperature protection function is determined by the voltage of SEL3 pin, shown as the following:

(a)  $SEL3 > V_{CC} - 0.3V$

**Acceptable ABV/BBV Range:**

**Before initial timer: 0.16V~2.7V**

**After initial timer: 0.69V~2.7V**

#### Temperature Protection Mode:

Entering charge-suspending mode when temperature is either too low or too high, same as abnormal battery voltage. Latch for charge-suspending function is provided for high temperature protection, but not for low temperature protection.

(b)  $V_{CC} - 1.4V > SEL3 > \frac{V_{CC}}{2} - 0.4V$

**Acceptable ABV/BBV Range:**

**Before initial timer: 0.16V~2.7V**

**After initial timer: 0.69V~2.7V**

#### Temperature Protection Mode:

If temperature is too high, battery charging is regarded as completed. If temperature is too low, function of  $\Delta T / \Delta t$  detection is disabled, just as thermistor is not existing.

(c)  $\frac{V_{CC}}{2} - 0.4V > SEL3 > 1.4V$

**Acceptable ABV/BBV Range:**

**Before initial timer: 0.16V~2 V**

**After initial timer: 1.2V~2V**

#### Temperature Protection Mode:

Entering charge-suspending mode when temperature is either too low or too high, same as abnormal battery voltage. Latch for charge-suspending function is provided for high temperature protection, but not for low temperature protection.

- (d) **0.3V > SEL3**  
**Acceptable ABV/BBV Range:**  
 Before initial timer: **0.16V~2 V**  
 After initial timer: **1.2V~2V**

**Temperature Protection Mode:**

If temperature is too high, battery charging is regarded as completed. If temperature is too low, function of  $\Delta T / \Delta t$  detection is disabled, just as thermistor is not existing.

**Battery Voltage Measurement**

The AIC1782 measures the battery voltage through ABV and BBV pins, which is connected to battery positive terminal through a resistor-divider network, as shown in Fig. 2. The acceptable limit of divided battery voltage is determined by the input voltage of SEL3 pin.

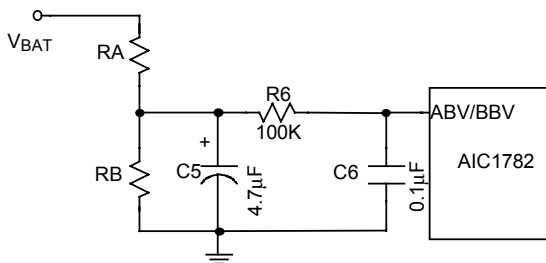

**Fig. 2 Battery Voltage Divider**

For  $SEL3 > (V_{CC}/2) + 0.4V$ , the suggested divider resistances of RA and RB for the corresponding number of battery cells are as below:

BATTERY CELLS	RA/RB	RA (KΩ)	RB (KΩ)
2~4	2	240	120
3~6	3.3	300	91
4~8	4.9	300	62
5~10	6.4	300	47
6~12	7.8	310	39
8~16	10.8	390	36

For  $SEL3 < (V_{CC}/2) - 0.4V$ , the suggested divider resistances of RA and RB for the corresponding number of battery cells are as below:

BATTERY CELLS	RA/RB	RA(KΩ)	RB (KΩ)
2	1	240	240
3	2	240	120
4	3	240	80
5	4	300	75
6	5	300	60
8	7	360	51
10	9	360	40
12	11	390	36
16	15	410	27

**Battery Temperature Measurement**

The AIC1782 employs a negative temperature coefficient (NTC) thermistor to measure the battery's temperature. The thermistor is inherently nonlinear with respect to temperature. To reduce the effect of nonlinearity, a resistor-divider network in parallel with the thermistor is recommended. A typical application circuit is shown in Fig. 3.

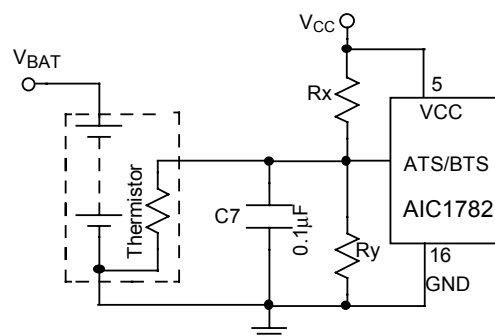

**Fig. 3 Battery Temperature Sense Circuit with a Negative Temperature Coefficient (NTC) Thermistor**

The calculation for Rx and Ry in the circuit is as following.

$$0.29 V_{CC} = \frac{R_y // R_{TH}}{R_x + (R_y // R_{TH})} \times V_{CC}$$

$R_{TH}$  = The resistance of thermistor at upper limit of temperature protection.

$$0.72 V_{CC} = \frac{R_y // R_{TH}}{R_x + (R_y // R_{TL})} \times V_{CC}$$

$R_{TL}$  = The resistance of thermistor at lower limit of temperature protection.

Substitution and rearranging the equations yield

$$R_x = 2.061 \times \frac{R_{TL} \times R_{TH}}{R_{TL} - R_{TH}}$$

$$R_y = \frac{5.3 \times R_{TL} \times R_{TH}}{R_{TL} - 6.3 R_{TH}}$$

If temperature characteristic of the thermistor is like that of SEMITEC 103AT-2, the resistance of Rx and Ry is tabulated for different TL and TH as below.

(note: TL is lower temperature limit and TH is upper temperature limit.)

**TABLE. 1 Values of Rx and Ry at TL = 0°C**

TH (°C)	Rx(KΩ)	Ry (KΩ)
50	10.1	551.1
51	9.7	300.7
52	9.4	204.8
53	9.0	153.9
54	8.7	122.8
55	8.4	101.8
56	8.1	86.5
57	7.8	75.0
58	7.5	66.0
59	7.2	58.7
60	7.0	52.8
61	6.8	47.8
62	6.5	43.6
63	6.3	39.9
64	6.1	36.8
65	5.9	34.0
66	5.7	31.6

67	5.5	29.5
68	5.3	27.5
69	5.2	25.8
70	5.0	24.3

**TABLE. 2 Values of Rx and Ry at TL = -10°C**

TH (°C)	Rx (KΩ)	Ry (KΩ)
45	11.4	95.6
46	11.0	85.0
47	10.6	76.2
48	10.2	68.9
49	9.8	62.8
50	9.5	57.5
51	9.1	52.9
52	8.8	48.8
53	8.5	45.3
54	8.2	42.1
55	7.9	39.4
56	7.6	36.8
57	7.4	34.6
58	7.1	32.5
59	6.9	30.7
60	6.7	29.0
61	6.4	27.4
62	6.2	26.0
63	6.0	24.6
64	5.8	23.4
65	5.6	22.2

### Setting the ADJ Pin Voltage

The slope of  $\Delta T / \Delta t$  detection is determined by ADJ pin voltage of the AIC1782.

The calculation of ADJ pin voltage is shown in the following procedure followed by an example.

#### Procedure

- (a) First, determine the temperature protection limits TH and TL. Then, substitute TH & TL into the following equation:

$$\frac{\Delta V_{TS}}{\Delta T_{BASE}} = \frac{0.72V_{CC} - 0.29V_{CC}}{TH - TL} = \frac{0.43V_{CC}}{TH - TL}$$

- (b) Determine the safety timer to obtain the value of  $\Delta t_{BASE}$ .

$$\Delta t_{BASE}(\text{sec.}) = \frac{56(\text{sec.})}{80(\text{min.})} \times \text{Safety Timer (min.)}$$

- (c) Determine the expected slope of  $\Delta T / \Delta t$  at which temperature rises  $y^\circ\text{C}$  in  $x$  seconds and fast charge is subsequently cut off.

$$\frac{\Delta T}{\Delta t} = \frac{y}{x}$$

- (d) Calculate the value of  $V_{ADJ}$

$$V_{ADJ} = 25 \times \frac{\Delta V_{TS}}{\Delta T_{BASE}} \times \frac{\Delta T}{\Delta t} \times \Delta t_{BASE}$$

### Example

- (a) Let  $TH=50^\circ\text{C}$ ,  $TL=0^\circ\text{C}$ ,  $V_{CC}=5\text{V}$ . We have

$$\frac{\Delta V_{TS}}{\Delta T_{BASE}} = \frac{0.43 \times 5}{50 - 0} = 0.043 \text{ V}/^\circ\text{C}$$

which means that  $V_{TS}$  decreases 43mV as temperature rises  $1^\circ\text{C}$ .

- (b) If safety timer is equal to 80 minutes,  $\Delta t_{BASE}$  is then 56 seconds.

- (c) If fast charge should be terminated when temperature rises  $1^\circ\text{C}$  in 60 seconds, then

$$\Delta T / \Delta t = \frac{1}{60} = 0.0166$$

- (d)  $V_{ADJ} = 25 \times 0.043 \times 0.0166 \times 56 = 1(\text{V})$

If the temperature range is from  $0^\circ\text{C}$  to  $50^\circ\text{C}$ , the voltage of  $V_{ADJ}$  under different setting conditions should be set as tabulated below.

**TABLE. 3 ADJ Pin Voltage (TL=0°C, TH=50°C)**

S.T. \ $\Delta T / \Delta t$ (°C/min.)	0.75 (°C/min.)	1.0 (°C/min.)	1.25 (°C/min.)
40 min. (2C)	0.37	0.5	0.63
80 min. (1C)	0.75	1.0	1.25
120 min. (0.67C)	1.12	1.5	1.87
160 min. (0.5C)	1.5	2.0	2.5
200 min. (0.4C)	1.87	2.5	3.12
240 min. (0.33C)	2.25	3.0	3.75

A similar table for temperature range from  $0^\circ\text{C}$  to  $60^\circ\text{C}$  is as below.

**TABLE. 4 ADJ Pin Voltage (TL=0°C, TH=60°C)**

S.T. \ $\Delta T / \Delta t$ (°C/min.)	0.75 (°C/min.)	1.0 (°C/min.)	1.25 (°C/min.)
40 min. (2C)	0.31	0.42	0.52
80 min. (1C)	0.62	0.84	1.05
120 min. (0.67C)	0.94	1.25	1.56
160 min. (0.5C)	1.25	1.67	2.08
200 min. (0.4C)	1.56	2.08	2.60
240 min. (0.33C)	1.87	2.5	3.12

### Setting the Period of Safety Timer

The AIC1782 provides a method for linearly adjusting the period of safety timer with an external resistor connected from TMR pin to GND. The relation between safety timer length and the external resistor ( $R_{TMR}$ ) is shown in Fig. 4. The table following shows the resistor values for some of the commonly chosen safety timer periods. Also shown in the table is their corresponding oscillator frequencies.

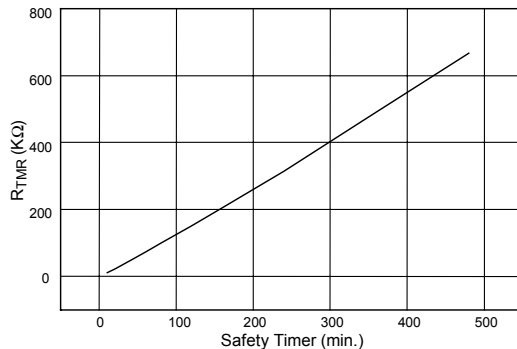
**Fig. 4 Safety Timer vs R<sub>TMR</sub>**

R <sub>TMR</sub> (KΩ)	Osc.Freq. (KHz)	Safety timer (min.)
11	262.4	10
23	131.2	20
48	65.6	40
74	43.7	60
100	32.8	80
152	21.9	120
206	16.4	160
314	10.9	240
491	7.3	360
667	5.5	480

### Selecting Mode of Operation

The AIC1782 provides three modes of operation: normal, test, and AC mode, determined by the setting of MODE pin according to TABLE 5. The AIC1782 will operate normally when the MODE pin is left floating (a 0.1μF capacitor is recommended to be tied to MODE pin if the charge circuit works in a noisy environment). When the MODE pin is biased to GND, the function of  $-\Delta V$  detection is disabled. When the MODE pin is biased to V<sub>CC</sub>, the AIC1782 enters the test mode. The test mode can be used to significantly reduce production test time. For relevant informations please contact AIC directly.

**ABLE. 5 The Operating Mode of AIC1782**

MODE pin	Mode	Function
V <sub>CC</sub>	Test	Safety timer period scaled down to 1/32.... etc.
Floating	Normal	Normal operation
GND	AC	$-\Delta V$ detection disabled

### The Mode of LED Display and Trickle Charge

The AIC1782 provides two LED display modes and five pulsed trickle charge modes. The modes of LED display and trickle charge are determined by the tri-level inputs, SEL1 and SEL2 pins, as in the TABLE 6.

**TABLE. 6 Mode of LED Display and Trickle Charge**

SEL1	SEL2	Trickle Charge Duty	LED Display Mode
V <sub>CC</sub>	V <sub>CC</sub>	N/A	Type 1
	Floating	1/32	Type 1
	GND	1/64	Type 1
Floating	V <sub>CC</sub>	1/128	Type 1
	Floating	1/256	Type 1
	GND	N/A	Type 2
GND	V <sub>CC</sub>	1/32	Type 2
	Floating	1/64	Type 2
	GND	1/128	Type 2

### Displaying the Battery Charging Status

The AIC1782 provides four open-drained outputs, in which LEA1 and LEA2 are used to indicate the battery charging status of pack A, yet LEB1 and LEB2 are used to indicate battery charging status of pack B. Refer to the table of LED display mode (TABLE 6), depending on the setting of SEL1 and SEL2 pins, the outputs of LEA1, LEA2, LEB1, and LEB2 pins are shown in the following table:

### TYPE 1

	Power On	Wait	Charge	Full	Abnormal
LEA1/ LEB1	1HZ	ON	ON	OFF	OFF
LEA2/ LEB2	OFF	ON	OFF	ON	OFF

### TYPE 2

	Power On	Wait	Charge	Full	Abnormal
LEA1/ LEB1	1HZ	1HZ	ON	OFF	4HZ
LEA2/ LEB2	1HZ	1HZ	4HZ	ON	OFF

### Charging Current Control

As shown in the typical application circuit, the AIC1782 offers two open-drained output pins, ICOA and ICOB pins, to control the charging current of battery pack A and pack B. When fast charge is completed, the AIC1782 enters the trickle charge mode. In trickle charge mode, the ICOA or ICOB pins output switch with predetermined duty cycle. Refer to the table of trickle charge mode (TABLE 6), the duty cycle is determined by the setting of SEL1 and SEL2 pins. The following table summarizes how ICOA and ICOB pins correspond to various charging states.

	Power ON	Wait ON	Fast Charging	Charge Completed	Fault Conditions
ICOA/ ICOB	ON	ON	OFF	See pin 14 & 15	ON

### Test Mode

Fig. 5 shows the timing diagram for externally controlled ADJ, ABV, BBV, ATS, BTS, SEL1 and SEL2 pin voltages of a recommended AIC1782 test scheme, utilizing TEST mode function. Output waveforms of LEA1, LEA2, LEB1, LEB2, ICOA and ICOB of a properly functioning AIC1782 are also shown in the figure. For detailed information please consult with AIC staffs directly.



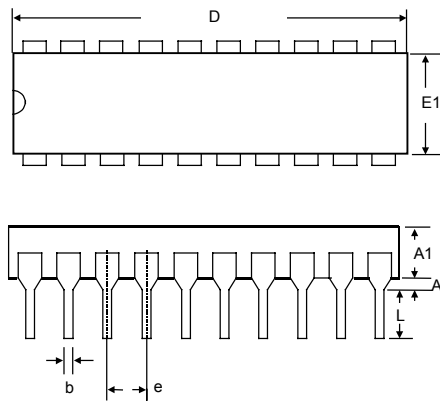

**PHYSICAL DIMENSIONS**
**20 LEAD PLASTIC DIP (unit: mm)**

SYMBOL	MIN	MAX
A1	0.381	—
A2	2.92	4.96
b	0.35	0.56
C	0.20	0.36
D	24.89	26.93
E	7.62	8.26
E1	6.09	7.12
e	2.54(TYP)	
eB	—	10.92
L	2.92	3.81

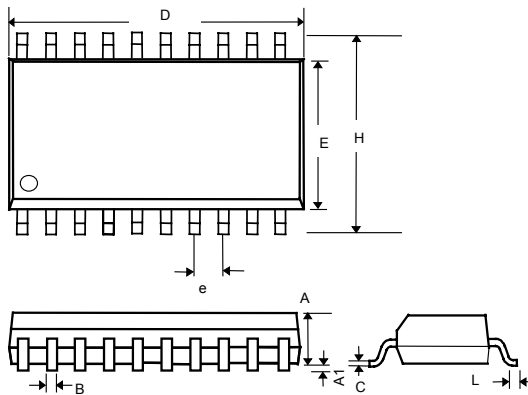
**20 LEAD PLASTIC SO (300 mil) (unit: mm)**

SYMBOL	MIN	MAX
A	2.35	2.65
A1	0.10	0.30
B	0.33	0.51
C	0.23	0.32
D	12.60	13.00
E	7.40	7.60
e	1.27(TYP)	
H	10.00	10.65
L	0.40	1.27