



82551QM Fast Ethernet Multifunction PCI /CardBus Controller

Networking Silicon - 82551QM

Datasheet

Product Features

- Enhanced IP Protocol Support
 - TCP, UDP, IPv4 Checksum Offload
 - Received Checksum Verification
- Quality of Service (QoS)
 - Multiple Priority Transmit Queues
- Optimum Integration for Lowest Cost Solution
 - Integrated IEEE 802.3 10BASE-T and 100BASE-TX compatible PHY
 - 32-bit PCI/CardBus master interface
 - Modem interface for combination solutions
 - Integrated power management functions
 - Thin BGA 15mm² package
- PHY detects polarity, MDI-X, and cable lengths. Auto MDI/MDI-X crossover at all speeds
- XOR tree mode support
- Wired for Reduced Total Cost of Ownership (TCO)
 - Wired for Management support
 - Integrated Alert Standard Format
 - ACPI and PCI Power Management standards compliance
 - Wake on “interesting” packets and link status change support
 - Magic Packet* support
 - Remote power up support
- High Performance Networking Functions
 - Early release
 - 8255x controller family chained memory structure
- Improved dynamic transmit chaining with multiple priorities transmit queues
- Full pin compatibility with the 82559 and 82550 controllers
- Backward compatible software to the 8255x controller family (IPSec not supported)
- Full Duplex support at 10 and 100 Mbps
- IEEE 802.3u Auto-Negotiation support
- 3 KB transmit and receive FIFOs
- Fast back-to-back transmission support with minimum interframe spacing
- IEEE 802.3x 100BASE-TX Flow Control support
- Adaptive Technology
- Low Power Features
 - Advanced Power Management capabilities
 - Low power 3.3 V device
 - Efficient dynamic standby mode
 - Deep power down support
 - Clock Run protocol support
- 82551QM Enhancements
 - Improved Bit Error Rate performance
 - Integrated UNDI ROM support
 - HWI support
 - Deep power-down state power reduction
- Lead-free¹ 196-pin Ball Grid Array (BGA). Devices that are lead-free are marked with a circled “e1” and have the product code: LUXXXXX.

¹ This device is lead-free. That is, lead has not been intentionally added, but lead may still exist as an impurity at <1000 ppm. The Material Declaration Data Sheet, which includes lead impurity levels and the concentration of other Restriction on Hazardous Substances (RoHS)-banned materials, is available at: ftp://download.intel.com/design/packtech/material_content_IC_Package.pdf#pagemode=bookmarks

In addition, this device has been tested and conforms to the same parametric specifications as previous versions of the device. For more information regarding lead-free products from Intel Corporation, contact your Intel Field Sales Representative.

317803-004
Revision 4.0



Revision History

Revision Date	Revision	Description
Oct 2001	0.6	<ul style="list-style-type: none">Removed references to IPSec support and changed description of FLA1/AUXPWR to use a pull-up resistor if auxiliary power is present, else leave it disconnected.Changed description of VCCR to show connecting it directly to main 3.3V supply and reduced text describing bus operations.Reduced PHY functional description to overview level and reorganized manageability section, adding ASF text. Added 0Fh as Revision ID and added targeted Icc specs.
Dec 2001	1.0	<ul style="list-style-type: none">Added description for No Connect pins and corrected typographical errors.
Apr 2002	2.0	Changed document status to Intel Confidential.
Mar 2003	2.1	<ul style="list-style-type: none">Removed document status and removed references to MDI/MDI-X feature, which is not supported by the 82551QM
Jun 2003	3.0	<ul style="list-style-type: none">Added information for the 82551IT.
Oct 2003	3.1	<ul style="list-style-type: none">Corrected operating temperature range in specifications to 0° to 70° C.
Mar 2004	3.11	<ul style="list-style-type: none">Added operating temperature reference to Section 1.1
Oct 2004	3.2	<ul style="list-style-type: none">Removed operating temperature reference to Section 1.1.Added references to MDI/MDI-X feature, which is now supported by the 82551QM and removed information for the 82551IT.
Nov 2004	3.3	<ul style="list-style-type: none">Updated the section describing "Multiple Priority Transmit Queues".Added information about migrating from a 2-layer 0.36 mm wide-trace substrate to a 2-layer 0.32 mm wide-trace substrate. Refer to the section on Package and Pinout Information.Added statement that no changes to existing soldering processes are needed for the 2-layer 0.32 mm wide-trace substrate change in the section describing "Package Information".
Jan 2005	3.4	<ul style="list-style-type: none">Added a note for PHY signals RBIAS100 and RBIAS10 to Table 9.
Apr 2006	3.5	<ul style="list-style-type: none">Changed case temperature specification to "0° C to 85° C".
Oct 2006	3.6	<ul style="list-style-type: none">Added Figure 31 "196 PBGA Package Pad Detail". The figure shows solder resist opening and metal diameter dimensions.
July 2007	3.7	<ul style="list-style-type: none">Added Section 15 "Reference Schematics", updated Section 12.1 (changed Tcase to ambient) and added ordering information to Section 1.4.
Sept 2007	3.8	<ul style="list-style-type: none">Updated Figures 34 and 35. Added Digital I/O and Crystal Input One (X1) Characteristics (Tables 70 and 71). Updated Section 5.8.4.
Mar 2008	3.9	<ul style="list-style-type: none">Updated Figure 35: changed TEST pull down resistor value (62 KΩ to 1 KΩ).
Nov 2008	4.0	<ul style="list-style-type: none">Updated Table 9 (X1 and X2 pin descriptions).Updated Tables 70 and 71 (Digital I/O and crystal input one (X1) characteristics).

Information in this document is provided in connection with Intel products. No license, express or implied, by estoppel or otherwise, to any intellectual property rights is granted by this document. Except as provided in Intel's Terms and Conditions of Sale for such products, Intel assumes no liability whatsoever, and Intel disclaims any express or implied warranty, relating to sale and/or use of Intel products including liability or warranties relating to fitness for a particular purpose, merchantability, or infringement of any patent, copyright or other intellectual property right. Intel products are not intended for use in medical, life saving, or life sustaining applications.

Intel may make changes to specifications and product descriptions at any time, without notice.

Designers must not rely on the absence or characteristics of any features or instructions marked "reserved" or "undefined." Intel reserves these for future definition and shall have no responsibility whatsoever for conflicts or incompatibilities arising from future changes to them.

The 82551QM may contain design defects or errors known as errata which may cause the product to deviate from published specifications. Current characterized errata are available on request.

Contact your local Intel sales office or your distributor to obtain the latest specifications and before placing your product order.

Copies of documents which have an ordering number and are referenced in this document, or other Intel literature, may be obtained from:

Intel Corporation
P.O. Box 5937
Denver, CO 80217-9808

or call in North America 1-800-548-4725, Europe 44-0-1793-431-155, France 44-0-1793-421-777, Germany 44-0-1793-421-333, other Countries 708-296-9333

Intel[®] is a trademark or registered trademark of Intel Corporation or its subsidiaries in the United States and other countries.

Copyright © 2008, Intel Corporation.

* Other product and corporate names may be trademarks of other companies and are used only for explanation and to the owners' benefit, without intent to infringe.



Contents

1.0	Introduction.....	1
1.1	Overview	1
1.2	Byte Ordering	1
1.3	References	1
1.4	Product Ordering Codes.....	2
2.0	Architectural Overview	3
2.1	Parallel Subsystem Overview.....	3
2.2	FIFO Subsystem Overview	4
2.3	Manageability Subsystem Overview	4
2.4	10/100 Mbps Serial CSMA/CD Unit Overview	4
2.5	10/100 Mbps Physical Layer Unit.....	4
3.0	Performance Enhancements.....	5
3.1	Multiple Priority Transmit Queues	5
3.2	Early Release.....	5
3.3	Hardware Integrity Support	6
3.4	Management Data Interface MDI/MDI-X Feature.....	6
4.0	Signal Descriptions.....	7
4.1	Signal Type Definitions	7
4.2	PCI Bus and CardBus Interface Signals	8
4.2.1	Address and Data Signals	8
4.2.2	Interface Control Signals	8
4.2.3	System and Power Management Signals	9
4.3	Local Memory Interface Signals.....	10
4.4	System Management Bus (SMB) Interface Signals	12
4.5	Test Port Signals	13
4.6	PHY Signals	13
4.7	Power and Ground Signals	14
5.0	Media Access Control Functional Description.....	15
5.1	Device Initialization.....	15
5.1.1	Initialization Effects.....	15
5.1.2	Initialization Effects on TCO Functionality.....	16
5.2	PCI and CardBus Interface	16
5.2.1	Bus Operations.....	16
5.2.2	Clock Run Signal.....	25
5.2.3	Power Management Event and Card Status Change Signals.....	25
5.3	PCI Power Management	26
5.3.1	Power States	26
5.3.2	Wake-up Events	30
5.4	CardBus Power Management	31
5.5	Wake on LAN (Preboot Wake-up).....	31
5.6	Parallel Flash/Modem Interface.....	32
5.7	Serial EEPROM Interface.....	33
5.8	10/100 Mbps CSMA/CD Unit.....	35



	5.8.1	Full Duplex	35
	5.8.2	Flow Control	36
	5.8.3	Address Filtering Modifications	36
	5.8.4	VLAN Support	36
	5.9	Media Independent Interface (MII) Management Interface	36
6.0		Physical Layer Functional Description	37
	6.1	100BASE-TX PHY Unit	37
	6.1.1	100BASE-TX Transmit Clock Generation	37
	6.1.2	100BASE-TX Transmit Blocks	37
	6.1.3	100BASE-TX Receive Blocks	37
	6.1.4	100BASE-TX Link Integrity Auto-Negotiation.....	38
	6.2	10BASE-T PHY Functions	38
	6.2.1	10BASE-T Transmit Clock Generation.....	38
	6.2.2	10BASE-T Transmit Blocks.....	38
	6.2.3	10BASE-T Receive Blocks.....	38
	6.2.4	10BASE-T Link Integrity and Full Duplex	39
	6.3	Auto-Negotiation	39
	6.3.1	Description	39
	6.3.2	Parallel Detect and Auto-Negotiation	39
	6.4	LED Description	40
7.0		Modem Functionality	43
	7.1	PCI Address Mapping to the Modem	43
	7.2	Modem Read and Write Cycles	43
	7.3	Modem and Preboot eXtension Environment Coexistence.....	43
	7.3.1	Programming Details.....	44
	7.3.2	Support Circuitry	44
8.0		Manageability Functionality.....	45
	8.1	Alert Standard Format.....	45
	8.2	Heartbeat	46
	8.3	Ping/Pong.....	46
	8.4	Watchdog	47
	8.5	Advanced Power Management Modes	47
	8.6	Polling	47
	8.7	Link Loss.....	47
	8.8	Acknowledge.....	47
9.0		Configuration Registers.....	49
	9.1	Function 0: LAN (Ethernet) PCI Configuration Space.....	49
	9.1.1	PCI Vendor ID and Device ID Registers	49
	9.1.2	PCI Command Register	50
	9.1.3	PCI Status Register.....	51
	9.1.4	PCI Revision ID Register.....	52
	9.1.5	PCI Class Code Register	52
	9.1.6	PCI Cache Line Size Register	53
	9.1.7	PCI Latency Timer	53
	9.1.8	PCI Header Type	53
	9.1.9	PCI Base Address Registers.....	53
	9.1.10	Base Address Registry Summary	56



- 9.1.11 CardBus Card Information Structure (CIS) Pointer56
- 9.1.12 PCI Subsystem Vendor ID and Subsystem ID Registers56
- 9.1.13 Capability Pointer57
- 9.1.14 Interrupt Line Register.....57
- 9.1.15 Interrupt Pin Register57
- 9.1.16 Minimum Grant Register58
- 9.1.17 Maximum Latency Register58
- 9.1.18 Capability ID Register.....58
- 9.1.19 Next Item Pointer.....58
- 9.1.20 Power Management Capabilities Register58
- 9.1.21 Power Management Control/Status Register (PMCSR).....59
- 9.1.22 Data Register60
- 9.2 Function 1: Modem PCI Configuration Space60
 - 9.2.1 Modem Configuration ID Register61
 - 9.2.2 Modem Command Register61
 - 9.2.3 Modem Status Register.....62
 - 9.2.4 Modem Revision ID Register.....62
 - 9.2.5 Modem Header Type Register62
 - 9.2.6 Modem I/O Base Address Register.....62
 - 9.2.7 Modem Memory Base Address Register.....63
 - 9.2.8 Modem CardBus CIS Pointer63
 - 9.2.9 Modem Subsystem Vendor ID Register63
 - 9.2.10 Modem Subsystem ID Register.....63
 - 9.2.11 Modem Capabilities Pointer63
 - 9.2.12 Modem Interrupt Register.....63
 - 9.2.13 Modem Power Management Capabilities Register63
 - 9.2.14 Modem Power Management Control/Status Register64
 - 9.2.15 Modem Data Register64
 - 9.2.16 Modem Support in PCI Mode64
- 10.0 Control/Status Registers65
 - 10.1 LAN (Ethernet) Control/Status Registers65
 - 10.1.1 System Control Block Status Word66
 - 10.1.2 System Control Block Command Word.....67
 - 10.1.3 System Control Block General Pointer.....67
 - 10.1.4 PORT67
 - 10.1.5 Flash Control Register.....67
 - 10.1.6 EEPROM Control Register.....68
 - 10.1.7 Management Data Interface Control Register.....68
 - 10.1.8 Receive Direct Memory Access Byte Count.....68
 - 10.1.9 Flow Control Register.....68
 - 10.1.10 Power Management Driver Register69
 - 10.1.11 General Control Register.....70
 - 10.1.12 General Status Register70
 - 10.1.13 Ethernet Card Status Change Registers70
 - 10.2 Statistical Counters73
 - 10.3 Modem Control/Status Registers75
 - 10.3.1 Modem Base Memory Addressing76
 - 10.3.2 Modem Base I/O Addressing76
 - 10.3.3 Modem CardBus CSTCHG Registers76



11.0	PHY Unit Registers	79
11.1	MDI Registers 0 - 7	79
11.1.1	Register 0: Control Register	79
11.1.2	Register 1: Status Register	80
11.1.3	Register 2: PHY Identifier Register	81
11.1.4	Register 3: PHY Identifier Register	81
11.1.5	Register 4: Auto-Negotiation Advertisement Register	81
11.1.6	Register 5: Auto-Negotiation Link Partner Ability Register	82
11.1.7	Register 6: Auto-Negotiation Expansion Register	82
11.2	MDI Registers 8 - 15	82
11.3	MDI Register 16 - 31	83
11.3.1	Register 16: PHY Unit Status and Control Register	83
11.3.2	Register 17: PHY Unit Special Control Register	83
11.3.3	Register 18: PHY Address Register	84
11.3.4	Register 19: 100BASE-TX Receive False Carrier Counter	84
11.3.5	Register 20: 100BASE-TX Receive Disconnect Counter	85
11.3.6	Register 21: 100BASE-TX Receive Error Frame Counter	85
11.3.7	Register 22: Receive Symbol Error Counter	85
11.3.8	Register 23: 100BASE-TX Receive Premature End of Frame Error Counter 85	85
11.3.9	Register 24: 10BASE-T Receive End of Frame Error Counter	85
11.3.10	Register 25: 10BASE-T Transmit Jabber Detect Counter	86
11.3.11	Register 26: Equalizer Control and Status Register	86
11.3.12	Register 27: PHY Unit Special Control Register	86
11.3.13	Register 28: MDI/MDI-X Control Register	87
11.3.14	Register 29: Hardware Integrity Control Register	87
12.0	Electrical and Timing Specifications	89
12.1	Absolute Maximum Ratings	89
12.2	DC Specifications	90
12.3	AC Specifications	93
12.4	Timing Specifications	94
12.4.1	Clocks Specifications	94
12.4.2	Timing Parameters	95
13.0	82551QM Test Port Functionality	103
13.1	Introduction	103
13.2	Test Function Description	103
13.2.1	Tristate	103
13.2.2	XOR Tree	104
14.0	Package and Pinout Information	107
14.1	Package Information	107
14.2	Pinout Information	109
14.2.1	Pin Assignments	109
14.2.2	Ball Grid Array Diagram	111
15.0	Reference Schematics	112



1.0 Introduction

This datasheet is applicable to the Intel® 82551QM Fast Ethernet Multifunction PCI/CardBus Controller, a member of the 8255x Fast Ethernet Controller family.

1.1 Overview

The 82551QM is an evolutionary addition to Intel's family of 8255x controllers. It provides excellent performance by offloading TCP, UDP and IP checksums and supports TCP segmentation off-load for operations such as Large Send.

Its optimized 32-bit interface and efficient scatter-gather bus mastering capabilities enable the 82551QM to perform high speed data transfers over the PCI bus or CardBus. This capability accelerates the processing of high level commands and operations, which lowers CPU utilization. Its architecture enables data to flow efficiently from the bus interface unit to the 3 KB Transmit and Receive FIFOs, providing the perfect balance between the wire and system bus. In addition, multiple priority queues are provided to prevent data underruns and overruns.

The 82551QM also integrates advanced manageability features into one component. It includes support for the Alerting Standards Forum (ASF) alert standard format bi-directional alerting and provides a Total Cost of Ownership (TCO) interface that can be used with bus management controllers. ASF sensor polling is supported, as well as remote control capabilities. The 82551QM embeds UNDI (Universal NIC Driver Interface) code, allowing it to support Preboot eXecutable Environment (PXE) without the use of additional external ROM.

The 82551QM includes both a MAC and PHY. It also has a simple interface to the analog front end, which allows cost effective designs requiring minimal board real estate. The 82551QM is pin compatible with the 82550 and 82559 family of controllers and is offered with software that provides backwards compatibility with previous 8255x controllers.

1.2 Byte Ordering

TCP and IP Internet Engineering Task Force (IETF) Request for Comments (RFCs) and literature use big endian (BE) byte ordering. This document uses big endian ordering for all IP and TCP frame formats. However, little endian byte ordering is used for referencing 82551QM memory resident structures and internal structures.

1.3 References

The following documents may provide further information on topics discussed in this document.

- 10/100 Mbit Ethernet Controller Family Software Developer's Manual. Intel Corporation.
- Advanced Configuration and Power Interface Specification, Revision 1.0. Intel Corporation, Microsoft Corporation, and Toshiba.
- IEEE 802.3x and 802.1y Standards.

- Network Device Class Power Management Reference Specification, Revision 1.0a. AMD, Inc. and Microsoft Corporation.
- System Management Bus (SMB) Specification. Smart Battery System Special Interest Group (SIG).
- 82551QM/ER/IT EEPROM Map and Programming Information. Intel Corporation
- 82562EZ(EX)/82551QM & 82540EM Combined Footprint LOM Design Guide. Intel Corporation

1.4 Product Ordering Codes

The product ordering code for the 82551QM is:

- GD82551QM (Leaded)
- LU82551QM (Lead Free)

Device	Stepping	MM Number	Specification	Notes
LU82551QM	A0	860610	S L7G5	Production (Tape and Reel)
LU82551QM	A0	860611		Production (Tray)
GD82551QM	A0	844662		Production (Tray)
GD82551QM	A0	844663	S L66W	Production (Tape and Reel)

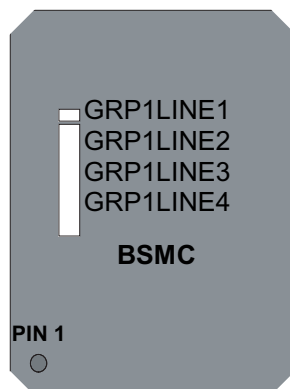

BSMC = Bottom-Side Mark Code

Figure 1. 82551QM Component Markings

Legend:

GRP1LINE1 - 82551QM
 GRP1LINE2 - (FPO)
 GRP1LINE3 - Blank
 GRP1LINE4 - (M) (C) '01 (leaded); (M) (C) '01 (e1) (lead free)



2.0 Architectural Overview

The Intel® 82551QM is divided into five main subsystems: a parallel subsystem, a FIFO subsystem, the manageability subsystem, a 10/100 Mbps Carrier Sense Multiple Access with Collision Detect (CSMA/CD) unit, and a 10/100 Mbps physical layer (PHY) unit.

2.1 Parallel Subsystem Overview

The parallel subsystem is comprised of several functional blocks: a PCI bus master interface, a micromachine processing unit and its corresponding microcode ROM, and a PCI Target Control/Flash/EEPROM/Modem interface. The parallel subsystem also interfaces to the FIFO subsystem, passing data (such as transmit, receive, and configuration data) and command and status parameters between these two blocks.

The dual function modem and PCI bus master interface provides a complete glueless interface to a PCI bus and is compliant with the PCI Bus Specification, Revision 2.2. The 82551QM provides 32 bits of addressing and data, as well as the PCI control interface. As a PCI target, it conforms to the PCI configuration scheme, which allows all accesses to the 82551QM to be automatically mapped into free memory and I/O space upon initialization of a PCI system. When transmit and receive data is processed, the 82551QM operates as a master on the PCI bus, initiating zero wait state transfers.

The 82551QM Control/Status Register Block is part of the PCI target element. The Control/Status Register block consists of the following 82551QM internal control registers: System Control Block (SCB), PORT, Flash Control, EEPROM Control, Modem Control and Management Data Interface (MDI) Control.

An embedded micromachine consisting of independent transmit and receive processing units allow the 82551QM to execute commands and receive incoming frames with no real time CPU intervention.

The 82551QM contains a multiplexed interface to connect an external serial EEPROM and Flash memory and modem. The Flash interface, which can also be used to connect to any standard 8-bit device, provides up to 128 KB of addressing to the Flash. Both read and write accesses are supported. The Flash can be used for remote boot functions, network statistical and diagnostics functions, and management functions. The Flash is mapped into host system memory (anywhere within the 32-bit memory address space) for software accesses. It is also mapped into an available boot expansion ROM location during boot time of the system. More information on the Flash interface is detailed in [Section 5.6, “Parallel Flash/Modem Interface”](#). The serial EEPROM is used to store relevant information for a LAN connection such as node address, as well as board manufacturing and configuration information. Both read and write accesses to the EEPROM are supported by the 82551QM. Information on the EEPROM interface is detailed in [Section 5.7, “Serial EEPROM Interface”](#). The modem interface uses an ISA-like signal and is described in more detail in [Section 7.0, “Modem Functionality”](#).



2.2 FIFO Subsystem Overview

The 82551QM FIFO subsystem consists of independent 3 KB transmit and receive FIFOs. Each FIFO provides a temporary buffer for frames as they are transmitted or received. Transmit frames queued within the transmit FIFO allow back-to-back transmission within the minimum Interframe Spacing (IFS). The FIFOs allow the 82551QM to withstand long PCI bus latencies without losing incoming data. Additional attributes of the FIFOs that enhance performance and functionality are:

- Tunable transmit FIFO threshold allows elimination of underruns while concurrent transmits are being performed.
- Extended PCI zero wait state burst accesses to and from the 82551QM for both transmit and receive FIFOs
- Efficient re-transmission of data directly from the transmit FIFO when physical or data link errors (collision detection or data underrun) are encountered, increasing performance by eliminating the need to re-access the data from host memory
- Automatic discard of incoming runt receive frames

2.3 Manageability Subsystem Overview

The 82551QM's Manageability subsystem supports bi-directional ASF, version 1.0. In addition, it provides a Total Cost of Ownership (TCO) interface that enables connection with alerting and management controllers such as the Intelligent Platform Management Interface (IPMI) solutions and Baseboard Management Controllers (BMCs).

2.4 10/100 Mbps Serial CSMA/CD Unit Overview

The 82551QM's CSMA/CD unit allows it to be connected to a 10 or 100 Mbps Ethernet network at half or full duplex. The CSMA/CD unit performs all of the functions of the 802.3 protocol such as frame formatting, frame stripping, collision handling, deferral to link traffic, etc.

2.5 10/100 Mbps Physical Layer Unit

The integrated Physical Layer (PHY) unit of the 82551QM allows connection to either a 10 or 100 Mbps Ethernet network. The PHY supports Auto-Negotiation for 100BASE-TX Full Duplex, 100BASE-TX Half Duplex, 10BASE-T Full Duplex, and 10BASE-T Half Duplex. Three LED pins indicate link status, network activity, and speed.

3.0 Performance Enhancements

All of Intel's Fast Ethernet controllers have the ability to support full wire speeds. The 82551QM has been designed to provide improved networking throughput. Performance is limited to the system's ability to feed data to the network controller.

As networks grow, the task of servicing the network becomes a large burden on the platform. System bottlenecks prevent optimal performance in typical operating conditions. Thus, to help alleviate these issues, Network Operating System (NOS) vendors are establishing normalized off-load specifications. These specifications define the types of off-load support required by the OS and interface between the network drivers. The 82551QM provides support for these initiatives and enables an improvement in platform network efficiency. With the pervasiveness of Internet Protocols, the off-load capabilities have focused on improving IP efficiency. As part of this effort, the 82551QM includes support for Multiple Priority Transmit Queues.

3.1 Multiple Priority Transmit Queues

The 82551QM supports two queues: High Priority Queue (HPQ) and Low Priority Queue (LPQ). The 82551QM provides a method for the driver to modify the HPQ while processing data. A new read only register is defined in the Control/Status Register (CSR) that enables the driver to change the transmit priority of elements within the HPQ. When software reads this register, the address of the next Command Block to be processed by the 82551QM on the HPQ is returned. After reading this register, software can freely modify the next Command Block (for example, overwrite it with a different Command Block) and any subsequent Command Block, without any conflict with the 82551QM.

Note: The 82551QM Windows* driver supports the Command Block Pointer register (in the CSR).

3.2 Early Release

Like the 82558, 82559 and 82550, the 82551QM supports a 3 KB transmit FIFO. The 82551QM provides a transmit FIFO enhancement called "early release" that effectively increases the amount of free capacity in the transmit FIFO. The enabling of early release is controlled through configuration space and occurs when the following conditions are met:

1. The transmitted frame is the oldest one in the queue (in other words, it is located at the head of the queue).
2. The transmitted frame has been completely transferred to the XMT-SRAM and processed (for example, XSUM). Large frames (greater than 3 KB) are never candidates for an early release.
3. When the preemptive queue mechanism is on, a frame which satisfies condition 2 may not satisfy condition 1 and therefore will not benefit from an early release.
4. More than 128 bytes have already been transferred to the XMT-SYNC-FIFO. This condition guarantees that at least one slot time elapsed (collision window).



3.3 Hardware Integrity Support

Cabling problems are a common cause for network downtime situations. Hardware Integrity (HWI) can help reduce this by locating cabling problems, which reduces Total Cost of Ownership (TCO). It uses transmission line theory to measure the arrival time and electrical characteristics of the wave reflected from an incident test wave launched on the media. With these measurements, opens, shorts, and degraded cable quality can be located along the wire.

HWI is controlled and activated by software. The Hardware Integrity Control, register 29 of the MDI Registers, is used for activating HWI (Section 11.3.14, “Register 29: Hardware Integrity Control Register”).

3.4 Management Data Interface MDI/MDI-X Feature

The 82551QM controller MDI/MDI-X feature provides the ability to automatically detect the required cable connection type and configure the controller-side MAU to the cable type. This feature effectively allows all properly wired Ethernet cables usable with any Ethernet device to be connected to the 82551QM without any additional external logic.

This advanced feature enables auto-correction of incorrect cabling with respect to cross-over versus straight-through cables. The 82551QM can identify the cable connection type and adjust its MDI port to the cable by switching between the TD and RD pairs. The auto-switching is done prior to the start of the hardware auto negotiation algorithm.

In a standard straight-through RJ-45 port configuration, the transmit pair is on contacts 1 and 2, and the receive pair on contacts 3 and 6. These are defined by Clause 23.7.1 of the IEEE 802.3u standard.

Table 1 lists the connections for both straight-through and cross-over RJ-45 ports for comparison.

Table 1. RJ-45 Connections

RJ-45 Contact	Straight-Through MDI Signal ^a	Cross-Over MDIX Signal ^b
1	TD+	RD+
2	TD-	RD-
3	RD+	TD+
4	Not Used	Not Used
5	Not Used	Not Used
6	RD-	TD-
7	Not Used	Not Used
8	Not Used	Not Used

- a. Straight-through connections used on DTE applications.
 b. Cross-over connections used on Hub and Switch applications.

4.0 Signal Descriptions

4.1 Signal Type Definitions

Table 2. Signal Type Descriptions

Type	Name	Description
IN	Input	The input pin is a standard input only signal.
OUT	Output	The output pin is a Totem Pole Output pin and is a standard active driver.
TS	Tri-State	The tri-state pin is a bidirectional, input/output pin.
STS	Sustained Tri-State	The sustained tri-state pin is an active low tri-state signal owned and driven by one agent at a time. The agent asserting the STS pin low must drive it high at least one clock cycle before floating the pin. A new agent can only assert an STS signal low one clock cycle after it has been tri-stated by the previous owner.
OD	Open Drain	The open drain pin allows multiple devices to share this signal as a wired-OR.
AI	Analog Input	The analog input pin is used for analog input signals.
AO	Analog Output	The analog output pin is used for analog output signals.
B	Bias	The bias pin is an input bias.
DPS	Digital Power Supply	Digital power or ground for the device.
APS	Analog Power Supply	Analog power or ground for the device.



4.2 PCI Bus and CardBus Interface Signals

4.2.1 Address and Data Signals

Table 3. Address and Data Signals

Symbol	Type	Name and Function
AD[31:0]	TS	Address and Data. The address and data lines are multiplexed on the same PCI pins. A bus transaction consists of an address phase followed by one or more data phases. During the address phase, the address and data lines contain the 32-bit physical address. For I/O, this is a byte address; for configuration and memory, it is a Dword address. The 82551QM uses little-endian byte ordering (in other words, AD[31:24] contain the most significant byte and AD[7:0] contain the least significant byte). During the data phases, the address and data lines contain data.
C/BE#[3:0]	TS	Command and Byte Enable. The bus command and byte enable signals are multiplexed on the same PCI pins. During the address phase, the C/BE# lines define the bus command. During the data phase, the C/BE# lines are used as Byte Enables. The Byte Enables are valid for the entire data phase and determine which byte lanes carry meaningful data.
PAR	TS	Parity. Parity is even across AD[31:0] and C/BE#[3:0] lines. It is stable and valid one clock after the address phase. For data phases, PAR is stable and valid one clock after either IRDY# is asserted on a write transaction or TRDY# is asserted on a read transaction. Once PAR is valid, it remains valid until one clock after the completion of the current data phase. The master drives PAR for address and write data phases; and the target, for read data phases.

4.2.2 Interface Control Signals

Table 4. Interface Control Signals

Symbol	Type	Name and Function
FRAME#	STS	Cycle Frame. The cycle frame signal is driven by the current master to indicate the beginning and duration of a transaction. FRAME# is asserted to indicate the start of a transaction and de-asserted during the final data phase.
IRDY#	STS	Initiator Ready. The initiator ready signal indicates the bus master's ability to complete the current data phase and is used in conjunction with the target ready (TRDY#) signal. A data phase is completed on any clock cycle where both IRDY# and TRDY# are sampled asserted (low) simultaneously.
TRDY#	STS	Target Ready. The target ready signal indicates the selected device's ability to complete the current data phase and is used in conjunction with the initiator ready (IRDY#) signal. A data phase is completed on any clock cycle where both IRDY# and TRDY# are sampled asserted (low) simultaneously.
STOP#	STS	Stop. The stop signal is driven by the target to indicate to the initiator that it wishes to stop the current transaction. As a bus slave, STOP# is driven by the 82551QM to inform the bus master to stop the current transaction. As a bus master, STOP# is received by the 82551QM to stop the current transaction.

Table 4. Interface Control Signals

Symbol	Type	Name and Function
IDSEL	IN	Initialization Device Select. The initialization device select signal is used by the 82551QM as a chip select during PCI configuration read and write transactions. This signal is provided by the host in PCI systems. In a CardBus system, this pin should not be connected.
DEVSEL#	STS	Device Select. The device select signal is asserted by the target once it has detected its address. As a bus master, the DEVSEL# is an input signal to the 82551QM indicating whether any device on the bus has been selected. As a bus slave, the 82551QM asserts DEVSEL# to indicate that it has decoded its address as the target of the current transaction.
REQ#	TS	Request. The request signal indicates to the bus arbiter that the 82551QM desires use of the bus. This is a point-to-point signal and every bus master has its own REQ#.
GNT#	IN	Grant. The grant signal is asserted by the bus arbiter and indicates to the 82551QM that access to the bus has been granted. This is a point-to-point signal and every master has its own GNT#.
INTA#	OD	Interrupt A. The interrupt A signal is used to request an interrupt by the 82551QM. This is an active low, level-triggered interrupt signal.
SERR#	OD	System Error. The system error signal is used to report address parity errors. When an error is detected, SERR# is driven low for a single PCI clock.
PERR#	STS	Parity Error. The parity error signal is used to report data parity errors during all PCI transactions except a Special Cycle. The parity error pin is asserted two clock cycles after the error was detected by the device receiving data. The minimum duration of PERR# is one clock for each data phase where an error is detected. A device cannot report a parity error until it has claimed the access by asserting DEVSEL# and completed a data phase.

4.2.3 System and Power Management Signals

Table 5. System and Power Management Signals

Symbol	Type	Name and Function
CLK	IN	Clock. The Clock signal provides the timing for all PCI transactions and is an input signal to every PCI device. The 82551QM requires a PCI Clock signal (frequency greater than or equal to 16 MHz) for nominal operation. The 82551QM supports Clock signal suspension using the Clock Run protocol.
CLK_RUN#	IN/OUT OD	Clock Run. The Clock Run signal is used by the system to pause or slow down the PCI Clock signal. It is used by the 82551QM to enable or disable suspension of the PCI Clock signal or restart of the PCI clock. When the Clock Run signal is not used, this pin should be connected to an external pull-down resistor.
RST#	IN	Reset. The PCI Reset pin is used to place PCI registers, sequencers, and signals into a consistent state. When RST# is asserted, the 82551QM ignores other PCI signals and all PCI output signals will be tristated. The PCI Reset pin should be pulled high to the main digital power supply.
PME#	OD	Power Management Event. The Power Management Event signal indicates that a power management event has occurred in a PCI bus system.



Table 5. System and Power Management Signals

Symbol	Type	Name and Function
CSTSCHG/ WOL	OUT	Card Status Change/Wake on LAN* . This pin is multiplexed to provide Card Status Change or Wake on LAN signals. In a CardBus system, it is used as the Card Status Change output signal and is an asynchronous signal to the Clock signal. It indicates that a power management event has occurred in a CardBus system. In a PCI system, it is used as the WOL pin and provides a positive pulse of approximately 52 ms upon detection of an incoming Magic Packet*.
ISOLATE#	IN	Isolate . The Isolate pin is used to isolate the 82551QM from the PCI bus. It also provides PCI Reset pin functionality. When Isolate is active (low), the 82551QM does not drive its PCI outputs (except PME# and CSTSCHG) or sample its PCI inputs (including CLK and RST#). The ISOLATE# pin should be driven by the PCI Reset signal.
ALTRST#	IN	Alternate Reset . The Alternate Reset pin is used to reset the 82551QM on power-up. The Alternate Reset signal should be pulled high to the main digital power supply.
VIO	B IN	Voltage Input/Output . The VIO pin is the voltage bias pin and should be connected to a 5 V supply in a 5 V PCI signaling environment and a 3.3 V supply in 3.3 V signaling environment. For CardBus systems, it should be connected to the main digital power supply.

4.3 Local Memory Interface Signals

Note: All unused Flash Address and Data pins **MUST** be left floating. Some of these pins have undocumented test functionality and can cause unpredictable behavior if they are unnecessarily connected to a pull-up or pull-down resistor.

Table 6. Local Memory Interface Signals

Symbol	Type	Name and Function
FLD7:0	IN/OUT	Flash/Modem Data Input/Output . These pins are used for Flash/Modem data interface. These pins should be left floating if the Flash and modem are not used.
FLA16/ CLK25	IN/OUT	Flash Address 16/25 MHz Clock . This multiplexed pin is controlled by the status of the Flash Address 7 (FLA7) pin. If FLA7 is left floating, this pin is used as FLA16; otherwise, if FLA7 is connected to a pull-up resistor, this pin is used as a 25 MHz clock output. This pin should be left floating if the Flash and the CLK25 functionality are not used.
FLA15/EESK	OUT	Flash Address 15/EEPROM Data Output . During Flash accesses, this multiplexed pin acts as the Flash Address 15 output signal. During EEPROM accesses, it acts as the serial shift clock output to the EEPROM.
FLA14/ EEDO	IN/OUT	Flash Address 14/EEPROM Data Output . During Flash accesses, this multiplexed pin acts as the Flash Address 14 output signal. During EEPROM accesses, this pin accepts serial input data from the EEPROM Data Output pin.
FLA13/EEDI	OUT	Flash Address 13/EEPROM Data Input . During Flash accesses, this multiplexed pin acts as the Flash Address 13 output signal. During EEPROM accesses, this pin provides serial output data to the EEPROM Data Input pin.

Table 6. Local Memory Interface Signals

Symbol	Type	Name and Function
FLA12/ MCNTSM#	IN/OUT	Flash Address 12/Modem Central Site Mode. This multiplexed pin acts as the Flash Address 12 output signal in a non-modem card. If modem is enabled, it is used as an output signal to the modem. It is either floated by default or driven low by the Modem System Control Registers. This pin should be left floating if Flash and modem functionality are not used.
FLA11/MINT	IN/OUT	Flash Address 11/Modem Interrupt. This multiplexed pin acts as the Flash Address 11 output signal in a non-modem card. If modem is enabled, it is used as the Modem Interrupt input signal. This pin should be left floating if Flash and modem functionality are not used.
FLA10/ MRING#	IN/OUT	Flash Address 10/Modem Ring. This multiplexed pin acts as the Flash Address 10 output signal in a non-modem card. If modem is enabled, it is used as the Modem Ring input signal. This pin should be left floating if Flash and modem functionality are not used.
FLA9/MRST	IN/OUT	Flash Address 9/Modem Reset. This multiplexed pin acts as the Flash Address 9 output signal in a non-modem card. If modem is enabled, it acts as the Modem Reset signal with an active high output. This pin should be left floating if Flash and modem functionality are not used.
FLA8/ IOCHRDY	IN/OUT	Flash Address 8/ISA Input/Output Channel Ready. This multiplexed pin acts as the Flash Address 8 output signal in a non-modem card. If modem is enabled, it is used as the ISA IOCHRDY input signal. This pin should be left floating if Flash and modem functionality are not used.
FLA7/ CLKEN	IN/OUT	Flash Address 7/Clock Enable. This multiplexed pin acts as the Flash Address 7 output signal during nominal operation. When the power-on reset of the 82551QM is active, this pin acts as input control over the FLA 16/CLK25 output signal. If the FLA 7/CLKEN pin is connected to a pull-up resistor (3.3 K Ω), a 25 MHz clock signal is provided on the FLA16/CLK25 output; otherwise, it is used as FLA16 output. For systems that do not use the 25 MHz clock output or Flash, this pin should be left floating.
FLA6:2	OUT	Flash Address 6:2. These pins are used as Flash address outputs. If the modem is enabled, these pins carry modem address bits 6:2. These pins should be left floating if the Flash and modem are not used.
FLA1/ AUXPWR	TS	Flash Address 1/Auxiliary Power. This multiplexed pin acts as the Flash Address 1 output signal during nominal operation. If the modem is enabled, this pin carries modem address bit 1. When the power-on reset of the 82551QM is active (low), it acts as the power supply indicator. If the 82551QM is fed by auxiliary power, it should be connected to VCC through a pull-up resistor (3.3 K Ω). Otherwise, this pin should be left floating.
FLA0/ PCIMODE#	TS	Flash Address 0/PCI Mode. This multiplexed pin acts as the Flash Address[0] output signal during nominal operation. If the modem is enabled, this pin carries modem address bit 0. When power-on reset of the 82551QM is active (low), it acts as the input system type. If the 82551QM is used in a CardBus system, this pin should be connected to a pull-up resistor (3.3 K Ω); otherwise, the 82551QM considers the host as a PCI system. For PCI systems that do not use Flash or modem, this pin should be left floating.
EECS	OUT	EEPROM Chip Select. The EEPROM Chip Select signal is used to assert chip select to the serial EEPROM.



Table 6. Local Memory Interface Signals

Symbol	Type	Name and Function
FLCS#	OUT	Flash Chip Select. The Flash Chip Select pin provides an active low Flash or modem chip select signal. This signal in combination with the Modem Chip Select (MDMCS#) signal determines which device, Flash or modem, is being used. This pin should be left floating if Flash and modem functionality are not used.
FLOE#	OUT	Flash Output Enable. This pin provides an active low output enable control (read) to the Flash memory. If the modem is enabled, this is an active low output enable (read) of the modem. This pin should be left floating if Flash and modem functionality are not used.
FLWE#	OUT	Flash Write Enable. This pin provides an active low write enable control to the Flash memory. If the modem is enabled, this is an active low write enable to the modem. This pin should be left floating if Flash and modem functionality are not used.
MDMCS#	OUT	Modem Chip Select. This pin provides an active low modem chip select. When it is set to 0b, the Flash port is used as a modem port; when 1b, a Flash port. This pin should be left floating if Flash and modem are not used.

4.4 System Management Bus (SMB) Interface Signals

Table 7. System Management Bus (SMB) Interface Signals

Symbol	Type	Name and Function
SMBDATA	IN OD	Alert Bus Data. This signal is stable when the Alert Bus Clock signal is high. This open drain signal should be pulled high to V_{CC} in all cases.
SMBCLK	IN OD	Alert Bus Clock. This pin is used for the Alert Bus Clock signal. One clock pulse is generated for each data bit transferred. It is an open drain signal and should be pulled high to V_{CC} in all cases.
SMB_ALERT#/ LAN_PWR_GOOD	OD	Bus Alert/Main Power Good. This is a multiplexed pin used as the Bus Alert pin and Main Power Good pin. As the Bus Alert pin, it is used as an interrupt signal for a slave device on the Alert Bus. As the Main Power Good pin it indicates that the main power supply is stable. This pin must be pulled high to V_{CC} if it is not connected.

4.5 Test Port Signals

Table 8. Test Port Signals

Symbol	Type	Name and Function
TEST	IN	Test Port. If this input pin is high, the 82551QM enables the test port. During nominal operation this pin should be connected to a pull-down resistor.
TCK	IN	Test Port Clock. This pin is used for the Test Port Clock signal.
TI	IN	Test Port Data Input. This pin is used for the Test Port Data Input signal.
TEEXEC	IN	Test Port Execute Enable. This pin is used for the Test Port Execute Enable signal.
TO	OUT	Test Port Data Output. This pin is used for the Test Port Data Output signal.

Note: These test port signals are not JTAG compatible. As a result, a BSDL file is not required.

4.6 PHY Signals

Table 9. PHY Signals

Symbol	Type	Name and Function
X1	AI	Crystal Input One. X1 and X2 can be driven by an external 25 MHz crystal. Otherwise, X1 may be driven by an external 3.3 V metal-oxide semiconductor (MOS) level 25 MHz oscillator when X2 is left floating.
X2	AO	Crystal Input Two. X1 and X2 can be driven by an external 25 MHz crystal. Otherwise, X1 may be driven by an external 3.3 V MOS level 25 MHz oscillator when X2 is left floating.
TDP TDN	AO	Analog Twisted Pair Ethernet Transmit Differential Pair. These pins transmit the serial bit stream for transmission on the Unshielded Twisted Pair (UTP) cable. The current-driven differential driver can be two-level (10BASE-T) or three-level (100BASE-TX) signals depending on the mode of operation. These signals interface directly with an isolation transformer.
RDP RDN	AI	Analog Twisted Pair Ethernet Receive Differential Pair. These pins receive the serial bit stream from the isolation transformer. The bit stream can be two-level (10BASE-T) or three-level (100BASE-TX) signals depending on the mode of operation.
ACTLED#	OUT	Activity LED. The Activity LED pin indicates either transmit or receive activity. When activity is present, the activity LED is on (ACTLED# active low); when no activity is present, the activity LED is off. In Wake on LAN mode, the ACTLED# signal is used to indicate that the received frame passed MAC address filtering.
LILED#	OUT	Link Integrity LED. The Link Integrity LED pin indicates link integrity. If the link is valid in either 10 or 100 Mbps, the LED is on (LILED# active low); if link is invalid, the LED is off.
SPDLED#	OUT	Speed LED. The Speed LED pin indicates the speed. The speed LED will be on at 100 Mbps (SPDLED# active low) and off at 10 Mbps.



Table 9. PHY Signals

Symbol	Type	Name and Function
RBIAS100	B	Reference Bias Resistor (100 Mbps). This pin should be connected to a pull-down resistor. ^a
RBIAS10	B	Reference Bias Resistor (10 Mbps). This pin should be connected to a pull-down resistor. ^a
VREF	B	Voltage Reference. This pin is connected to a 1.25 V ± 1% external voltage reference generator. To use the internal voltage reference source, this pin should be left floating. Under normal circumstances, the internal voltage reference should be used and this pin would be left open.

a. Based on some board designs, RBIAS100 and RBIAS10 values may need to be increased/decreased to compensate for high/low MDI transmit amplitude. See the *82562EZ(EX)/82551QM & 82540EM Combined Footprint LOM Design Guide* for more information.

4.7 Power and Ground Signals

Table 10. Power and Ground Signals

Symbol	Type	Name and Function
VCC	DPS	Digital 3.3 V Power. The VCC pins should be connected to the main digital power supply. This is 3.3 V _{AUX} in systems with an auxiliary power supply and PCI power in systems without an auxiliary power supply. The power source is configured through the FLA1/AUXPWR pin.
VCCR	APS	Analog Power. These pins should be connected directly to VCC.
VSSPL, VSSPP, VSSPT, VSS	DPS	Digital Ground. These pins should be connected to the main digital ground plane.
NC	DPS	No Connect. These pins should not be connected to any circuit. Pull-up or pull-down resistors should not be used.

5.0 Media Access Control Functional Description

5.1 Device Initialization

The 82551QM has six sources for initialization. They are listed according to their precedence:

1. Internal Power-on Reset (POR)
2. ALTRST# pin
3. RST# pin
4. ISOLATE# pin
5. Software Reset (Software Command)
6. Selective Reset (Software Command)

5.1.1 Initialization Effects

The following table lists the effect of each of the different initialization sources on major portions of the 82551QM. The initialization sources are listed in order of precedence. For example, any resource that is initialized by the software reset is also initialized by the D3 to D0 transition and ALTRST# and RST# but not necessarily by the selective reset.

Table 11. Initialization Effects

	Internal POR	ALTRST#	RST#	ISOLATE#	D3 to D0 Transition	Software Reset	Selective Reset
EEPROM read and initialization	?	?	?	?	--	--	--
Loadable microcode decoded/reset	?	?	?	?	?	?	--
MAC configuration reset and multicast hash	?	?	?	?	?	?	--
Memory pointers and micro-machine state reset	?	?	?	?	?	?	?
PCI Configuration register reset	?	?	?	?	?	--	--
PHY configuration reset	?	?	?	--	--	--	--



Table 11. Initialization Effects

	Internal POR	ALTRST#	RST#	ISOLATE#	D3 to D0 Transition	Software Reset	Selective Reset
Power management event reset	?	?	Clear only if no auxiliary power present	Clear only if no auxiliary power present	--	--	--
Statistic counters reset	?	?	?	?	?	?	--
Sampling of configuration input pins	?	?	?	--	--	--	--

5.1.2 Initialization Effects on TCO Functionality

The 82551QM has the ability to be controlled by two masters, the host CPU on the PCI bus and the TCO controller on the SMB. The 82551QM may be initialized by the PCI bus during SMB operation. The table below lists the effect of those sources:

Table 12. Initialization Effects on TCO

Initialization Source	SMB Behavior	Status and Receive Enable
ALTRST#, RST#, or ISOLATE# ^a	The SMB is terminated instantaneously. ^b	Initialized to inactive
D3 to D0 transition	The SMB cycle is aborted. During SMB read commands, the 82551QM transfers zeros until the end of the cycle. An SMB write cycle has no effect on the 82551QM. The 82551QM asserts the SMB_ALERT# after a D3 to D0 transition. The 82551QM indicates its initialization status to the TCO controller via an active initialization bit in the Status Word.	Initialized to inactive
Software Reset, Selective Reset, or D3 to D0 transition	The SMB cycle is aborted. During SMB read commands, the 82551QM transfers zeros until the end of the cycle. An SMB write cycle has no effect on the 82551QM. After a software reset, the 82551QM reports its initialization in the same manner as in a D3 to D0 transition.	Unaffected

a. ISOLATE# acts as reset on its trailing edge. While the 82551QM is in the D3 power state, the RST# initializes the 82551QM on the trailing edge.

b. SMB commands in process will be terminated immediately.

5.2 PCI and CardBus Interface

5.2.1 Bus Operations

After configuration, the 82551QM is ready for its normal operation. As a Fast Ethernet Controller, the role of the 82551QM is to access transmitted data or deposit received data. In both cases the 82551QM, as a bus master device, will initiate memory cycles by way of the PCI bus.

To perform these actions, the 82551QM is controlled and examined by the CPU through its control and status structures and registers. Some of these structures reside in the 82551QM and some reside in system memory. For access to the 82551QM's Control/Status Registers (CSR), the 82551QM acts as a slave device. The 82551QM serves as a slave also while the CPU accesses its 128 KB Flash buffer or its EEPROM. When the 82551QM is in modem mode, it also acts as a slave. Details regarding modem interface are described in [Section 5.6, "Parallel Flash/Modem Interface"](#).

[Section 5.2.1.1](#) describes the 82551QM slave operation. It is followed by a description of the 82551QM operation as a bus master (initiator) in [Section 5.2.1.2](#).

5.2.1.1 Bus Slave Operation

The 82551QM serves as a target device in the following cases:

- CPU accesses to the 82551QM System Control Block (SCB) Control/Status Registers (CSR)
- CPU accesses to the EEPROM through its CSR
- CPU accesses to the 82551QM PORT address through the CSR
- CPU accesses to the MDI control register in the CSR
- CPU accesses to the Flash control register in the CSR
- CPU accesses to the 128 KB Flash

The CSR and the 1 MB Flash buffer are considered by the 82551QM as totally separated memory spaces. The 82551QM provides separate Base Address Registers (BARs) in the configuration space to distinguish between them. The size of the CSR memory space is 4 KB in the memory space and 64 bytes in the I/O space. The 82551QM treats accesses to these memory spaces differently.

5.2.1.1.1 Control/Status Register (CSR) Accesses

The 82551QM supports zero wait state single cycle memory or I/O mapped accesses to its CSR space. Separate BARs request 4 KB of memory space and 64 bytes of I/O space to accomplish these accesses. The 82551QM provides 4 valid KB of CSR space, which include the following elements:

- System Control Block (SCB) registers
- PORT register
- Flash control register
- EEPROM control register
- MDI control register
- Flow control registers
- CardBus registers

The following figures show CSR zero wait state I/O read and write cycles. In the case of accessing the Control/Status Registers, the CPU is the initiator and the 82551QM is the target of the transaction.

Figure 2. CSR I/O Read Cycle

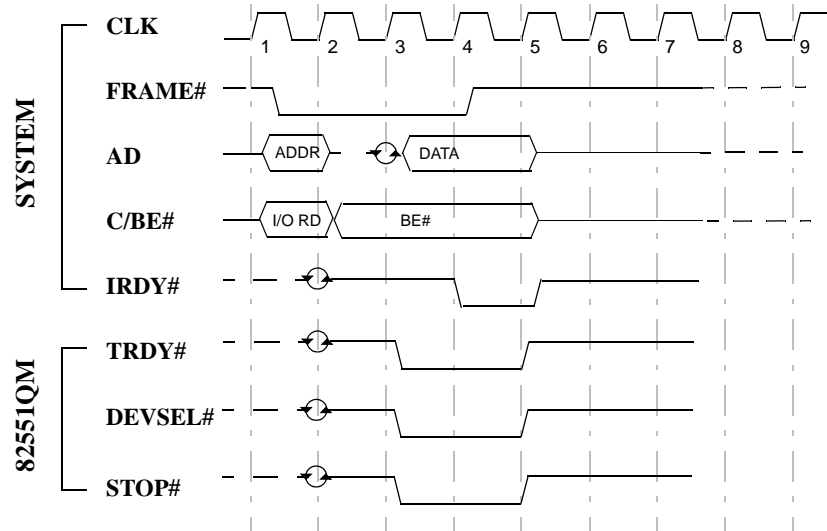

Read Accesses: The CPU, as the initiator, drives address lines AD[31:0], the command and byte enable lines C/BE#[3:0] and the control lines IRDY# and FRAME#. As a slave, the 82551QM controls the TRDY# signal and provides valid data on each data access. The 82551QM allows the CPU to issue only one read cycle when it accesses the Control/Status Registers, generating a disconnect by asserting the STOP# signal. The CPU can insert wait states by de-asserting IRDY# when it is not ready.

Figure 3. CSR I/O Write Cycle

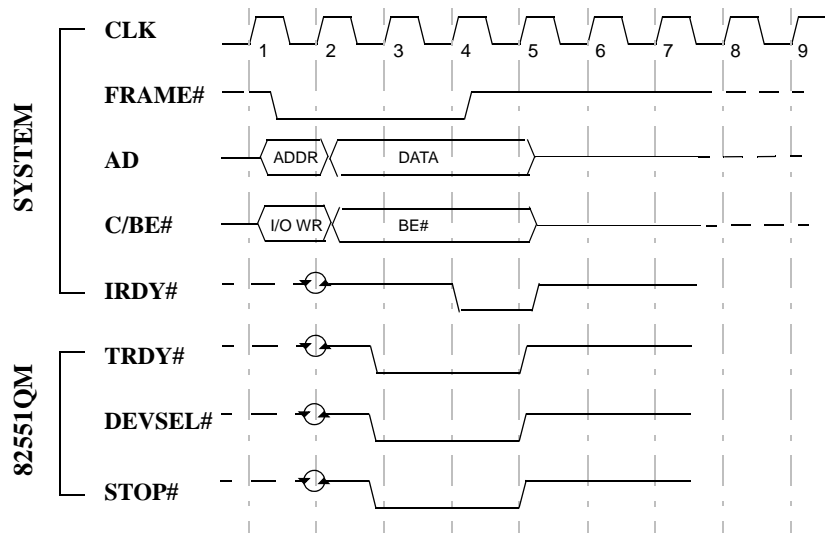

Write Accesses: The CPU, as the initiator, drives the address lines AD[31:0], the command and byte enable lines C/BE#[3:0] and the control lines IRDY# and FRAME#. It also provides the 82551QM with valid data on each data access immediately after asserting IRDY#. The 82551QM controls the TRDY# signal and asserts it from the data access. The 82551QM allows the CPU to issue only one I/O write cycle to the Control/Status Registers, generating a disconnect by asserting the STOP# signal. This is true for both memory mapped and I/O mapped accesses.

5.2.1.1.2 Flash Buffer Accesses

The CPU accesses to the Flash buffer are very slow and the 82551QM issues a target-disconnect at the first data access. The 82551QM asserts the STOP# signal to indicate a target-disconnect. The figures below illustrate memory CPU read and write accesses to the 128 KB Flash buffer. The longest burst cycle to the Flash buffer contains one data access only.

Figure 4. Flash Buffer Read Cycle

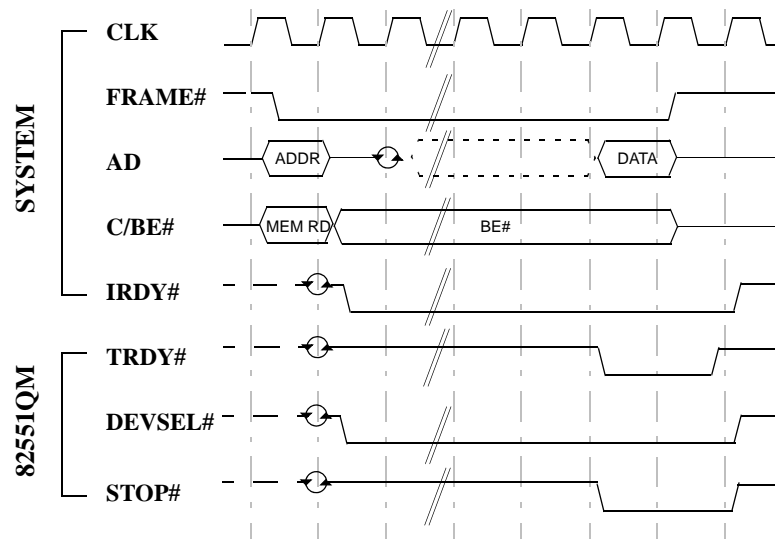

Read Accesses: The CPU, as the initiator, drives the address lines AD[31:0], the command and byte enable lines C/BE#[3:0] and the control lines IRDY# and FRAME#. The 82551QM controls the TRDY# signal and de-asserts it for a certain number of clocks until valid data can be read from the Flash buffer. When TRDY# is asserted, the 82551QM drives valid data on the AD[31:0] lines. The CPU can also insert wait states by de-asserting IRDY# until it is ready. Flash buffer read accesses can be byte or word length.



Figure 5. Flash Buffer Write Cycle

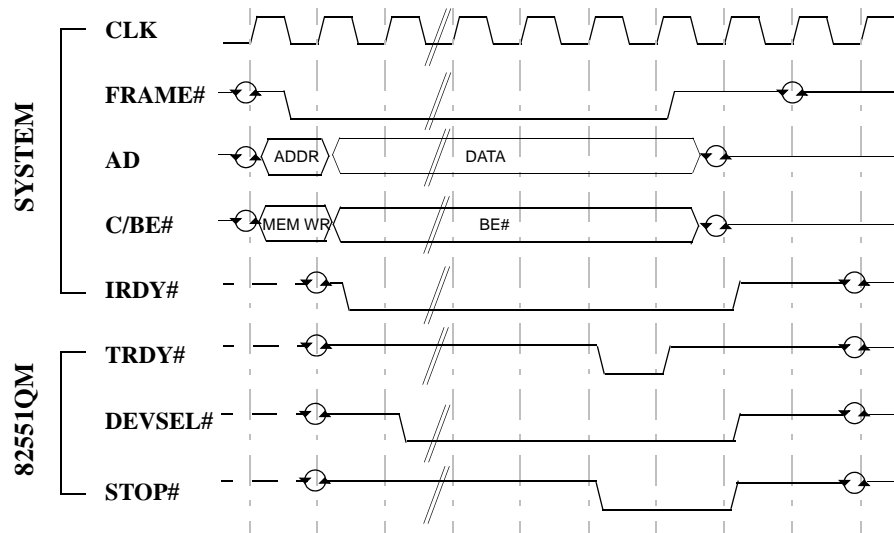

Write Accesses: The CPU, as the initiator, drives the address lines AD[31:0], the command and byte enable lines C/BE#[3:0] and the control lines IRDY# and FRAME#. It also provides the 82551QM with valid data immediately after asserting IRDY#. The 82551QM controls the TRDY# signal and de-asserts it for a certain number of clocks until valid data is written to the Flash buffer. By asserting TRDY#, the 82551QM signals the CPU that the current data access has completed. Flash buffer write accesses can be byte length only.

5.2.1.1.3 Retry Premature Accesses

The 82551QM responds with a Retry to any configuration cycle accessing the 82551QM before the completion of the automatic read of the EEPROM. The 82551QM may continue to Retry any configuration accesses until the EEPROM read is complete. The 82551QM does not enforce the rule that the retry master must attempt to access the same address again to complete any delayed transaction. Any master access to the 82551QM after the completion of the EEPROM read will be honored. Figure 6 below depicts how a Retry looks when it occurs.

Figure 6. PCI Retry Cycle

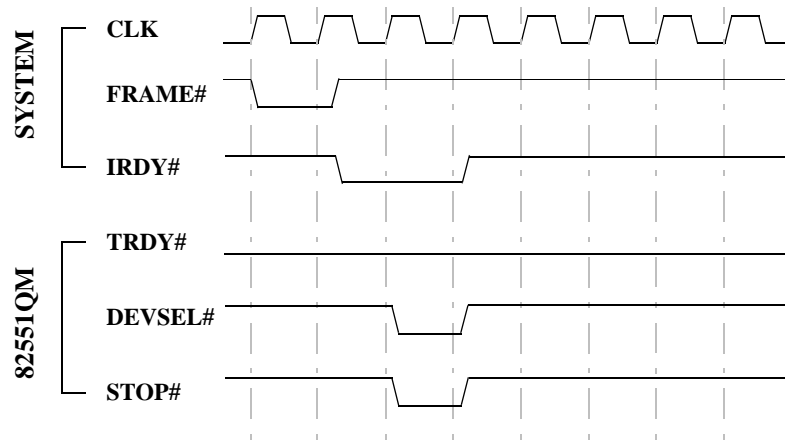

Note: The 82551QM is considered the target in the above diagram; thus, TRDY# is not asserted.

A Retry may also occur in the following two scenarios:

- Card Information Structure (CIS) in memory is accessed in CardBus mode.
- External modem registers are accessed and the modem does not assert IOCHRDY within 7 PCI clocks from the assertion of MDMCS#.

5.2.1.1.4 Error Handling

Data Parity Errors: The 82551QM checks for data parity errors while it is the target of the transaction. If an error was detected, the 82551QM always sets the Detected Parity Error bit in the PCI Configuration Status register, bit 15. The 82551QM also asserts PERR#, if the Parity Error Response bit is set (PCI Configuration Command register, bit 6). The 82551QM does not attempt to terminate a cycle in which a parity error was detected. This gives the initiator the option of recovery.

Target-Disconnect: The 82551QM prematurely terminates a cycle in the following cases:

- After accesses to the Flash buffer
- After accesses to its CSR
- After accesses to the configuration space



System Error: The 82551QM reports parity error during the address phase using the SERR# pin. If the SERR# Enable bit in the PCI Configuration Command register or the Parity Error Response bit is not set, the 82551QM only sets the Detected Parity Error bit (PCI Configuration Status register, bit 15). If SERR# Enable and Parity Error Response bits are both set, the 82551QM sets the Signaled System Error bit (PCI Configuration Status register, bit 14) as well as the Detected Parity Error bit and asserts SERR# for one clock.

Note: The 82551QM detects a system error for any parity error during an address phase, whether or not it is involved in the current transaction.

5.2.1.2 Bus Master Operation

As a PCI Bus Master, the 82551QM initiates memory cycles to fetch data for transmission or deposit received data and to access the memory resident control structures. The 82551QM performs zero wait state burst read and write cycles to the host main memory. Figure 7 and Figure 8 depict memory read and write burst cycles. For bus master cycles, the 82551QM is the initiator and the host main memory (or the PCI host bridge, depending on the configuration of the system) is the target.

Figure 7. Memory Read Burst Cycle

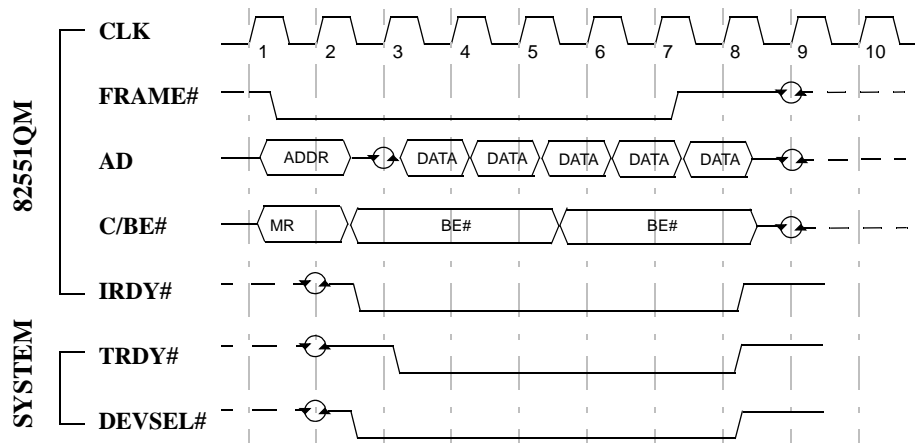
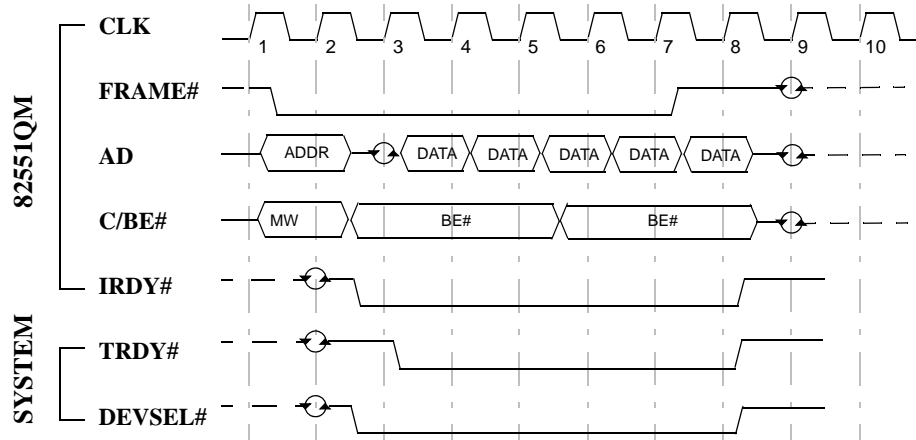

Figure 8. Memory Write Burst Cycle



The CPU provides the 82551QM with action commands and pointers to the data buffers that reside in host main memory. The 82551QM independently manages these structures and initiates burst memory cycles to transfer data to and from them. The 82551QM uses the Memory Read Multiple (MR Multiple) command for burst accesses to data buffers and the Memory Read Line (MR Line) command for burst accesses to control structures. For all write accesses to the control structure, the 82551QM uses the Memory Write (MW) command. For write accesses to data structure, the 82551QM may use either the Memory Write or Memory Write and Invalidate (MWI) commands.

Read Accesses: The 82551QM performs block transfers from host system memory to perform frame transmission on the serial link. In this case, the 82551QM initiates zero wait state memory read burst cycles for these accesses. The length of a burst is bounded by the system and the 82551QM's internal FIFO. The length of a read burst may also be bounded by the value of the Transmit DMA Maximum Byte Count in the Configure command. The Transmit DMA Maximum Byte Count value indicates the maximum number of transmit DMA PCI cycles that will be completed after an 82551QM internal arbitration.

The 82551QM, as the initiator, drives the address lines AD[31:0], the command and byte enable lines C/BE#[3:0] and the control lines IRDY# and FRAME#. The 82551QM asserts IRDY# to support zero wait state burst cycles. The target signals the 82551QM that valid data is ready to be read by asserting the TRDY# signal.

Write Accesses: The 82551QM performs block transfers to host system memory during frame reception. In this case, the 82551QM initiates memory write burst cycles to deposit the data, usually without wait states. The length of a burst is bounded by the system and the 82551QM's internal FIFO threshold. The length of a write burst may also be bounded by the value of the Receive DMA Maximum Byte Count in the Configure command. The Receive DMA Maximum Byte Count value indicates the maximum number of receive DMA PCI transfers that will be completed before the 82551QM internal arbitration.

The 82551QM, as the initiator, drives the address lines AD[31:0], the command and byte enable lines C/BE#[3:0] and the control lines IRDY# and FRAME#. The 82551QM asserts IRDY# to support zero wait state burst cycles. The 82551QM also drives valid data on AD[31:0] lines during each data phase (from the first clock and on). The target controls the length and signals completion of a data phase by de-assertion and assertion of TRDY#.



5.2.1.2.1 Memory Write and Invalidate

The 82551QM has four Direct Memory Access (DMA) channels. Of these four channels, the Receive DMA is used to deposit the large number of data bytes received from the link into system memory. The Receive DMA uses both the Memory Write (MW) and the Memory Write and Invalidate (MWI) commands. To use MWI, the 82551QM must guarantee the following:

1. Minimum transfer of one cache line
2. Active byte enable bits (or BE[3:0]# are all low) during MWI access
3. The 82551QM may cross the cache line boundary only if it intends to transfer the next cache line too.

To ensure the above conditions, the 82551QM may use the MWI command only if the following conditions are true:

1. The Cache Line Size (CLS) written in the CLS register during PCI configuration is 8 or 16 Dwords.
2. The accessed address is cache line aligned.
3. The 82551QM has at least 8 or 16 Dwords of data in its receive FIFO.
4. There are at least 8 or 16 Dwords of data space left in the system memory buffer.
5. The MWI Enable bit in the PCI Configuration Command register, bit 4, must be set to 1b.
6. The MWI Enable bit in the 82551QM Configure command must be set to 1b.

If any one of the above conditions is not true, the 82551QM uses the MW command. If an MWI cycle has started and one of the conditions is no longer valid (for example, the data space in the memory buffer is now less than CLS), then the 82551QM terminates the MWI cycle at the end of the cache line. The next cycle is either an MW or MWI cycle depending on the conditions listed above.

If the 82551QM started a MW cycle and reached a cache line boundary, it either continues or terminates the cycle depending on the Terminate Write on Cache Line configuration bit of the 82551QM Configure command (byte 3, bit 3). If this bit is set, the 82551QM terminates the MW cycle and attempts to start a new cycle. The new cycle is an MWI cycle if this bit is set and all of the above conditions are met. If the bit is not set, the 82551QM continues the MW cycle across the cache line boundary if required.

5.2.1.2.2 Read Align

The Read Align feature enhances the 82551QM's performance in cache line oriented systems. In these particular systems, starting a PCI transaction on a non-cache line aligned address may cause low performance.

To resolve this performance anomaly, the 82551QM attempts to terminate transmit DMA cycles on a cache line boundary and start the next transaction on a cache line aligned address. This feature is enabled when the Read Align Enable bit is set in the 82551QM Configure command (byte 3, bit 2).

If this bit is set, the 82551QM operates as follows:

- When the 82551QM is almost out of resources on the transmit DMA (that is, the transmit FIFO is almost full), it attempts to terminate the read transaction on the nearest cache line boundary.



- When the arbitration counter's feature is enabled (in other words, the Transmit DMA Maximum Byte Count value is set in the Configure command), the 82551QM switches to other pending DMAs on cache line boundary only.

This feature is not recommended for use in non-cache line oriented systems since it may cause shorter bursts and lower performance. If this feature is used, it is recommended that the CLS register in PCI Configuration space is set to 8 or 16.

5.2.1.2.3 Error Handling

Data Parity Errors: As an initiator, the 82551QM checks and detects data parity errors that occur during a transaction. If the Parity Error Response bit is set (PCI Configuration Command register, bit 6), the 82551QM also asserts PERR# and sets the Data Parity Detected bit (PCI Configuration Status register, bit 8). In addition, if the error was detected by the 82551QM during read cycles, it sets the Detected Parity Error bit (PCI Configuration Status register, bit 15).

5.2.2 Clock Run Signal

The CLK_RUN# signal is used to control the PCI clock as defined in the CardBus specification and PCI Mobile design guide and is compliant with both the CardBus specification and PCI Mobile design guide. This signal is active in both the CardBus and PCI bus operating modes. The Clock Run signal is an open drain I/O signal. It is used as a bidirectional channel between the host and the devices.

- The host de-asserts the CLK_RUN# signal to indicate that the clock is about to be stopped or slowed down to a non-operational frequency.
- The host asserts the CLK_RUN# signal when the clock is either running at a normal operating frequency or about to be started.
- The 82551QM asserts the CLK_RUN# signal to indicate that the PCI clock must prevent the host from stopping or to request that the host restore the clock if it was previously stopped.

Proper operation requires that the system latency from the nominal PCI CLK to CLK_RUN# assertion should be less than 0.5 μ s. If the system latency is longer than 0.5 μ s, there is an increase in receive overruns. In these types of systems, the Clock Run functionality should be disabled. In this case, the 82551QM claims the PCI clock even during idle time. If the CLK_RUN# signal is not used, it must be connected to a pull-down resistor.

5.2.3 Power Management Event and Card Status Change Signals

The 82551QM supports power management indications in the PCI and CardBus mode. In CardBus systems, the CSTSCHG pin is used for power management event indication. The PME# output pin provides an indication of a power management event in PCI systems. The CSTSCHG pin is supported by four registers located in the Control/Status Register (Section 10.0, "Control/Status Registers" describes these registers in more detail).



5.3 PCI Power Management

The 82551QM supports a larger set of wake-up packets and the capability to wake the system on a link status change from a low power state. These added power management enhancements enable the 82551QM to adhere to emerging standards. The 82551QM enables the host system to be in a sleep state and remain virtually connected to the network. After a power management event or link status change is detected, the 82551QM wakes the host system. The sections below describe these events, the 82551QM power states, and estimated power consumption at each power state.

5.3.1 Power States

The 82551QM contains two sets of power management registers, one for PCI and one for CardBus. The has one set of PCI power management registers and implements all four power states as defined in the Power Management Network Device Class Reference Specification, Revision 1.0. The four device power states, D0 through D3, vary from maximum power consumption at D0 to the minimum power consumption at D3.

PCI transactions are only allowed in the D0 state, except for host accesses to the 82551QM's PCI configuration registers. The D1 and D2 power management states enable intermediate power savings while providing the system wake-up capabilities. In the D3 cold state, the 82551QM can provide wake-up capabilities only if auxiliary power is supplied. Wake-up indications from the 82551QM are provided by the Power Management Event (PME#) signal in PCI implementations and the Card Status Change (CSTSCHG) signal in CardBus designs.

In addition to providing a host interface through the PCI bus, the 82551QM provides TCO controller access through a dedicated System Management Bus (SMB). Additional information on the supported TCO functionality at all power states is described in [Section 8.0, "Manageability Functionality"](#).

5.3.1.1 D0 Power State

As defined in the Network Device Class Reference Specification, the device is fully functional in the D0 power state. In this state, the 82551QM receives full power and should be providing full functionality. In the 82551QM the D0 state is partitioned into two substates, D0 Uninitialized (D0u) and D0 Active (D0a).

D0u is the 82551QM's initial power state following a Power-on Reset (POR) event and before the Base Address Registers (BARs) are accessed. While in the D0u state, the 82551QM has PCI slave functionality to support its initialization by the host and supports Wake on LAN mode. Initialization of the CSR, Memory, or I/O Base Address Registers in the PCI Configuration space switches the 82551QM from the D0u state to the D0a state.

In the D0a state, the 82551QM provides its full functionality and consumes nominal power. In addition, the 82551QM supports wake on link status change ([Section 5.3.2, "Wake-up Events"](#)). While it is active, the 82551QM requires a nominal PCI clock signal (in other words, a clock frequency greater than 16 MHz) for proper operation. During idle time, the 82551QM supports a PCI clock signal suspension using the Clock Run signal mechanism. The 82551QM supports a dynamic standby mode. In this mode, the 82551QM is able to save almost as much power as it does in the static power-down states. The transition to or from standby is done dynamically by the 82551QM and is transparent to the software.

5.3.1.2 D1 Power State

For a device to meet the D1 power state requirements, as specified in the Advanced Configuration and Power Interface (ACPI) Specification, Revision 1.0, it must not allow bus transmission or interrupts; however, bus reception is allowed. Therefore, device context may be lost and the 82551QM does not initiate any PCI activity. In this state, the 82551QM responds only to PCI accesses to its configuration space and system wake-up events.

The 82551QM retains link integrity and monitors the link for any wake-up events such as wake-up packets or link status change. Following a wake-up event, the 82551QM asserts the PME# signal to alert the PCI system or the CSTSCHG signal for a CardBus system.

5.3.1.3 D2 Power State

The ACPI D2 power state is similar in functionality to the D1 power state. If the bus is in the B2 bus power state, the 82551QM will consume less current than it does in the D1 state. In addition to D1 functionality, the 82551QM can provide a lower power mode with wake-on-link status change capability. The 82551QM may enter this mode if the link is down while the 82551QM is in the D2 state. In this state, the 82551QM monitors the link for a transition from an invalid link to a valid link. The 82551QM will not attempt to keep the link alive by transmitting idle symbols or link integrity pulses.¹ The sub-10 mA state due to an invalid link can be enabled or disabled by a configuration bit in the Power Management Driver Register (PMDR).

5.3.1.4 D3 Power State

In the D3 power state, the 82551QM has the same capabilities and consumes the same amount of power as it does in the D2 state. However, it enables the PCI system to be in the Bus Power 3 (B3) state. If the PCI system is in the B3 state (in other words, no PCI power is present), the 82551QM provides wake-up capabilities if it is connected to an auxiliary power source in the system. If PME is disabled, the 82551QM does not provide wake-up capability or maintain link integrity. In this mode, the 82551QM consumes minimal power.

The 82551QM enables a system to be in a sub-5 watt state (low power state) and still be virtually connected. More specifically, the 82551QM supports full wake-up capabilities while it is in the D3 cold state. The 82551QM can be connected to an auxiliary power source (V_{AUX}), which enables it to provide wake-up functionality while the PCI power is off. The typical current consumption of the 82551QM is 125 mA at 3.3 V and a dual power plane is not required. If connected to an auxiliary power source, the 82551QM receives all of its power from the auxiliary source in all power states. When connected to an auxiliary power supply, the 82551QM must have a status indicator of whether the power supply is valid (in other words, auxiliary power is stable). The indication is received at the AUXPWR pin, as described next.

1. For a topology of two 82551QM devices connected by a crossed twisted-pair Ethernet cable, the deep power-down mode should be disabled. If it is enabled, the two devices may not detect each other if the operating system places them into a low power state before both nodes become active.



5.3.1.4.1 Auxiliary Power Signal

The 82551QM senses whether it is connected to the PCI power supply or to an auxiliary power supply (V_{AUX}) through the FLA1/AUXPWR pin. The auxiliary power detection pin (multiplexed with FLA1) is sampled when the 82551QM power-on reset is active. An external pull-up resistor should be connected to the 82551QM if it is fed by V_{AUX} ; otherwise, the FLA1/AUXPWR pin should be left floating. The presence of AUXPWR affects the value reported in the Power Management Capability Register (PCI Configuration Space, offset DEh). The Power Management Capability Register is described in more detail in [Section 9.1.20, “Power Management Capabilities Register”](#).

5.3.1.4.2 Alternate Reset Signal

The 82551QM's ALTRST# input pin functions as a power-on reset input. Following ALTRST# being driven low, the 82551QM is initialized to a known state. While this function is required, this pin is not needed for it. Since this functionality is provided by the 82551QM's internal power-on reset signal, this pin should be pulled high to the main digital power supply.

Note: A separate internal power-on reset signal is generated when power is applied to the device. This signal is active while it provides the 82551QM power-on reset function and is also used for sampling configuration inputs.

5.3.1.4.3 Isolate Signal

When the 82551QM is connected to V_{AUX} , it can be powered on while the PCI bus is powered off. In this case, the 82551QM isolates itself from the PCI bus. The 82551QM has a dedicated ISOLATE# pin that must be connected to the PCI Reset signal. Whenever the PCI Bus is in the B3 state, the PCI Reset signal becomes active and the 82551QM isolates itself from the PCI bus. During this state, the 82551QM ignores all PCI signals including the RST# and CLK input signals. It also tristates all PCI outputs, except the PME# signal. In the transition to an active PCI power state (in other words, from B3 bus power state to B0 bus power state), the PCI Reset signal shifts high. This generates an internal hardware reset, which initializes the device (described in [Section 5.1.1, “Initialization Effects”](#)).

Some designs in existence may implement the previous recommendations for the RST#, ISOLATE# and ALTRST# input pins. In these cases, the PCI Reset signal is connected to the RST# pin, the PCI power source's stable power (power good) to the ISOLATE# pin, and the auxiliary power source's stable power (auxiliary power good) to the ALTRST# pin. It is not necessary for existing working designs to make changes for these signals; however, it is recommended that the changes contained in this document should be included when possible. New designs should implement the recommendations contained in this document.

5.3.1.4.4 Reset Signal

The RST# signal can be activated in one of the following cases:

- Power-up
- Warm boot
- Wake-up (B3 to B0 transition)
- Set to power-down (B0 to B3 transition)

If PME is enabled (in the PCI power management registers), the RST# signal does not affect any PME related circuits (in other words, the CSTSCHG registers (CardBus only), PCI power management registers, and the wake-up packet would not be affected).

Note: The PCI Specification, Revision 2.2, states that the RST# signal should be active low in the B3 state. (In PCI Specification, Revision 2.1, the RST# signal is undefined during the B3 state.)

The transition from the B3 bus power state to the B0 bus power state occurs on the trailing edge of the RST# signal.

The initialization signal is generated internally in the following cases:

- Active RST# signal while the 82551QM is the D0, D1, or D2 power state
- RST# trailing edge while the 82551QM is in the D3 power state
- ISOLATE# trailing edge

The internal initialization signal resets the PCI Configuration Space, MAC configuration, and memory structure.

The behavior of the RST# and ISOLATE# pins and the internal 82551QM initialization signal are shown in the following figure.

Figure 9. Initialization upon RST# and ISOLATE#

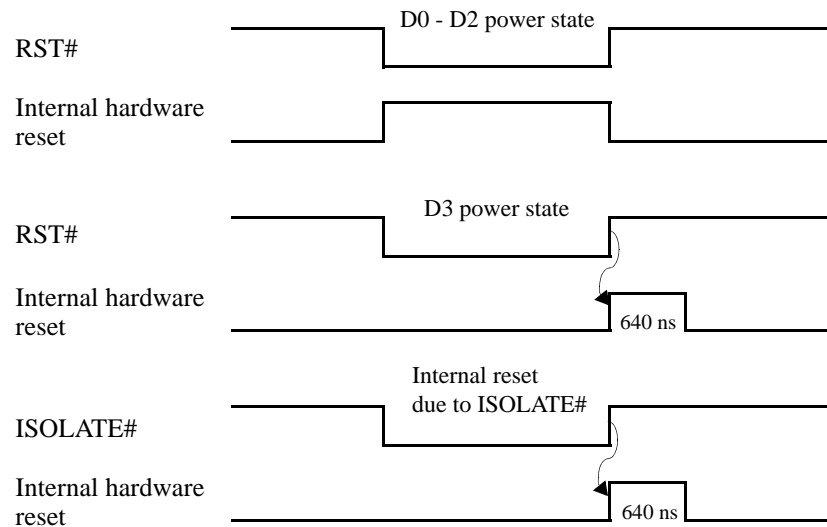



The following tables list the functionality at the different power states for the 82551QM.

Table 13. Functionality at the Different Power States

Power State	Link	Functionality
D0u	Don't care	<ul style="list-style-type: none"> Power-up state PCI slave access
D0a	Valid	Full functionality at full power and wake on an invalid link
	Invalid	Full functionality at full power and wake on a valid link
D1	Valid	<ul style="list-style-type: none"> Wake-up on "interesting" packets and link invalid PCI configuration access
	Invalid	<ul style="list-style-type: none"> Wake on link valid PCI configuration access
D2	Valid	Same functionality as D1 (link valid)
	Invalid	Detection for valid link and no link integrity
D3 (with power)	Valid	Same functionality as D1 (link valid)
	Invalid	Detection for valid link and no link integrity
Dx (x>0 without PME#)	Don't care	No wake-up functionality Note: If the TCO bit is set in the EEPROM, the 82551QM will not disable the link function and will consume power as in the D2 state.

5.3.2 Wake-up Events

There are two types of wake-up events: "Interesting" Packets and Link Status Change. These two events are detailed below.

Note: The wake-up event is supported only if the PME Enable bit in the Power Management Control/Status (PMCSR) register is set. The PMCSR is described in [Section 9.1.21, "Power Management Control/Status Register \(PMCSR\)"](#).

5.3.2.1 "Interesting" Packet Event

In the power-down state, the 82551QM is capable of recognizing "interesting" packets. The 82551QM supports pre-defined and programmable packets that can be defined as any of the following:

- Address Resolution Protocol (ARP) Packets (with Multiple IP addresses)
- Direct Packets (with or without type qualification)
- Magic Packet*
- Neighbor Discovery Multicast Address Packet ("ARP" in IPv6 environment)
- NetBIOS over TCP/IP (NBT) Query Packet (under IPv4)
- Internetwork Package Exchange* (IPX*) Diagnostic Packet
- TCO Packet



This allows the 82551QM to handle various packet types. In general, the 82551QM supports programmable filtering of any packet in the first 128 bytes.

When the 82551QM is in one of the low power states, it searches for a predefined pattern in the first 128 bytes of the incoming packets. The only exception is the Magic Packet, which is scanned for the entire frame. The 82551QM classifies the incoming packets into one of the following categories:

- **No Match.** The 82551QM discards the packet and continues to process the incoming packets.
- **TCO Packet.** The 82551QM implements perfect filtering of TCO packets. After a TCO packet is processed, the 82551QM is ready for the next incoming packet. There are two possible system environments:
 - **TCO controller on the SMB.** The entire TCO packet is transferred to the TCO controller.
 - **System without TCO controller.** TCO packets are treated as any other wake-up packets and may assert the PME# signal if configured to do so.
- **Wake-up Packet.** The 82551QM is capable of recognizing and storing the first 128 bytes of a wake-up packet. If a wake-up packet is larger than 128 bytes, its tail is discarded by the 82551QM. After the system is fully powered-up, software has the ability to determine the cause of the wake-up event through the PMDR and dump the stored data to the host memory. Magic Packets are an exception. The Magic Packets may cause a power management event and set an indication bit in the PMDR; however, it is not stored by the 82551QM for use by the system when it wakes up.

5.3.2.2 Link Status Change Event

The 82551QM link status indication circuit is capable of issuing a PME on a link status change from a valid link to an invalid link condition or vice versa. The 82551QM reports a PME link status event in all power states. The PME# signal is gated by the PME Enable bit in the PMCSR and the CSMA Configure command.

5.4 CardBus Power Management

The CardBus Power Management Proposal differs from the PCI Power Management Specification in the following manner:

- The PME# signal is replaced by CSTSCHG which is an active high output signal.
- An auxiliary power source, V_{AUX} , is supplied on the same V_{cc} pins.
- An auxiliary power source bit in the PMC register must be set.
- The PCI clock signal and the PCI reset signal are guaranteed to be kept low in the B3 state.

In addition, the 82551QM also meets the CardBus requirement for current consumption less than 70 mA in the D0u state.

5.5 Wake on LAN (Preboot Wake-up)

When the 82551QM is drawing power from an auxiliary power source (V_{AUX}), it can support the same preboot Wake on LAN (WOL) capabilities as the 82559 device. The 82551QM enters WOL mode after the following events occur:



- An ALTRST# is completed.
- The 82551QM reads the EEPROM and the WOL bit is set.

When the 82551QM is in WOL mode:

- The 82551QM scans incoming packets for a Magic Packet. When it receives a Magic Packet, the 82551QM asserts the PME# signal (until cleared) and the CSTSCHG signal for 52 ms.
- The Activity LED changes its functionality to indicate that the received frame passed Individual Address (IA) filtering or broadcast filtering.
- The PCI Configuration registers are accessible to the host.
- Software must not attempt to access the Flash.

The 82551QM switches from WOL mode to the D0a power state following a setup of the Memory or I/O Base Address Registers in the PCI Configuration space. If the 82551QM receives a Magic Packet while it is in the D0u, D1, D2, or D3 power state, it issues a positive pulse on the CSTSCHG pin. This pulse is cleared by a later non-Wake on LAN message. For PCI systems and in designs that support the 3-pin header standard, the CSTSCHG pin acts as the WOL signal.

5.6 Parallel Flash/Modem Interface

The 82551QM's parallel interface is used for Flash interface only or modem interface only. The 82551QM supports a glueless interface to an 8-bit wide, 128 KB, parallel memory device. The parallel local port is multiplexed with a modem interface in a LAN/modem combination card.

The Flash (or boot PROM) is read from or written to whenever the host CPU performs a read or a write operation to a memory location that is within the Flash mapping window. All accesses to the Flash, except read accesses, require the appropriate command sequence for the device used. (Refer to the specific Flash data sheet for more details on reading from or writing to the Flash device.) The accesses to the Flash are based on a direct decode of CPU accesses to a memory window defined in either the 82551QM Flash Base Address Register (PCI Configuration space at offset 18h) or the Expansion ROM Base Address Register (PCI Configuration space at offset 30h). The 82551QM asserts control to the Flash when it decodes a valid access.

The 82551QM supports an external Flash memory (or boot PROM) of up to 128 KB. The Expansion ROM address can be separately disabled by setting the corresponding bit in the EEPROM, word Ah.

Note: Flash accesses must always be assembled or disassembled by the 82551QM whenever the access is greater than a byte-wide access. Due to slow access times to a typical Flash and to avoid violating PCI bus holding specifications (no more than 16 wait states inserted for any cycles that are not system initiation cycles), the maximum data size is either one word or one byte for a read operation and one byte only for a write operation.

Note: In mobile applications, the MDMCS# pin enables the modem controller or Flash device.

5.7 Serial EEPROM Interface

The serial EEPROM stores configuration data for the 82551QM and is a serial in/serial out device. The 82551QM supports either a 64-register or 256-register size EEPROM and automatically detects the EEPROM's size. A 256-word EEPROM device is required for a Cardbus system and contains the CIS information. A 256-word EEPROM device is also required for a TCO enabled system to hold the heartbeat packet. The EEPROM should operate at a frequency of at least 1 MHz.

All accesses, either read or write, are preceded by a command instruction to the device. The address field is six bits for a 64-register EEPROM or eight bits for a 256-register EEPROM. The end of the address field is indicated by a dummy zero bit from the EEPROM, which indicates the entire address field has been transferred to the device. An EEPROM read instruction waveform is shown in the figure below.

Figure 10. 64-Word EEPROM Read Instruction Waveform

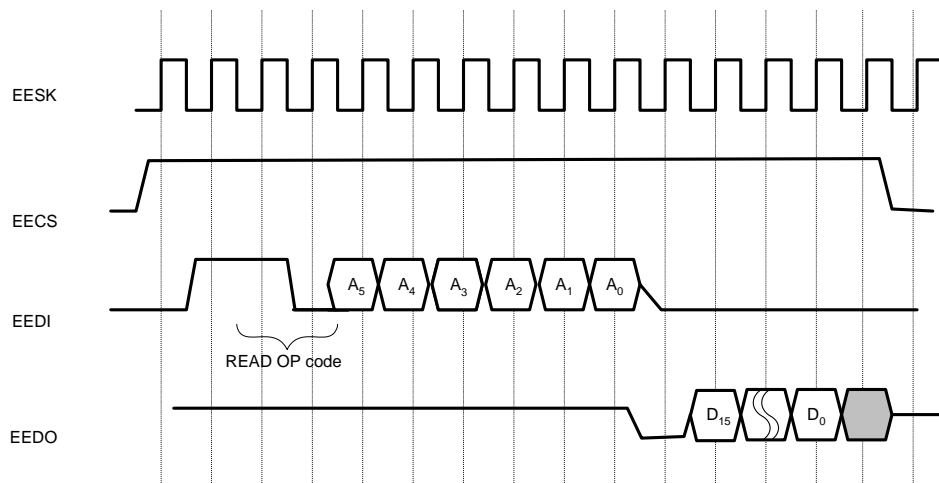

The 82551QM can also use the EEPROM for heartbeat packet transmission (systems without a TCO controller are also supported). In these designs, the EEPROM is accessed through time windows autonomously by the 82551QM hardware. During these time windows, the 82551QM will respond with a PCI Retry to both EEPROM and Flash accesses.

The 82551QM performs an automatic read of five words (0h, 1h, 2h, Ah, and Dh) of the EEPROM after the de-assertion of Reset. It may read six more words (Bh, Ch, FBh, FCh, FDh, and FEh) if the modem bit is set in the EEPROM (word Ah, bit 0). Refer to the *82551QM/ER/IT EEPROM Map and Programming Information* for more details.



The 82551QM EEPROM format is shown below in [Table 14](#).

Table 14. EEPROM Address Map

Word	High Byte (Bits 15 – 8)	Low Byte (Bits 7 – 0)
00h	Ethernet Individual Address Byte 2	Ethernet Individual Address Byte 1
01h	Ethernet Individual Address Byte 4	Ethernet Individual Address Byte 3
02h	Ethernet Individual Address Byte 6	Ethernet Individual Address Byte 5
03h	Compatibility Byte 1	Compatibility Byte 0
04h	Reserved	
05h	Controller Type	Connectors
06h	Primary PHY Record (high byte)	Primary PHY Record (low byte)
07h	Secondary PHY Record (high byte)	Secondary PHY Record (low byte)
08h	PWA Byte 1	PWA Byte 2
09h	PWA Byte 3	PWA Byte 4
0Ah	EEPROM_ID (high byte)	EEPROM_ID (low byte)
0Bh	Subsystem_ID (high byte)	Subsystem_ID (low byte)
0Ch	Subsystem_Vendor (high byte)	Subsystem_Vendor (low byte)
0Dh	Configuration and Heartbeat Pointer	SMB Address and Card Information Structure Pointer
0Eh	Reserved	
0Fh	Reserved	
10h	Alerting APM Register	Alerting Mask Register
11h	Alerting Watchdog Data	Alerting Watchdog 1 Data
12h	Alerting Heartbeat Value	Alerting Watchdog Value
13h	Alerting RPC Value	Alerting RTM Value
14h	Alerting Enable Register	Alerting Control Register
15h	Alerting Poll 1 Register	Alerting Poll 1 Address
16h	Alerting Poll 1 Event Code	Alerting Poll 1 Data Mask
17h	Alerting Poll 2 Register	Alerting Poll 2 Address
18h	Alerting Poll 2 Event Code	Alerting Poll 2 Data Mask
19h	Alerting Poll 3 Register	Alerting Poll 3 Address
1Ah	Alerting Poll 3 Event Code	Alerting Poll 3 Data Mask
1Bh	Alerting Poll 4 Register	Alerting 2 Poll 4 Address
1Ch	Alerting Poll 4 Event Code	Alerting Poll 4 Data Mask
1Dh	Alerting Reset/Power Descriptor Register	Alerting Reset/Power Descriptor Address
1Eh	Alerting Reset Descriptors	Alerting Reset Descriptors
1Fh	ARP Enable	IP Address Pointer
20h:22h	Reserved	
23h	Device ID (high byte)	Device ID (low byte)
24h – 2Fh	Reserved	
30h:33h	Intel Boot Agent Configuration	



Table 14. EEPROM Address Map (Continued)

Word	High Byte (Bits 15 – 8)	Low Byte (Bits 7 – 0)
32h – 3Eh	Reserved	
3Fh	64-word EEPROM Checksum (high byte)	64-word EEPROM Checksum (low byte)
40h:F7h	Controlled by the ASF Agent	
F8h:FEh	Reserved for Software	
FFh	256-word EEPROM Checksum, high byte	256-word EEPROM Checksum, low byte

Note: Refer to the *82551QM/ER/IT EEPROM Map and Programming Information* for more details.

5.8 10/100 Mbps CSMA/CD Unit

The 82551QM CSMA/CD unit implements both the IEEE 802.3 Ethernet 10 Mbps and IEEE 802.3u Fast Ethernet 100 Mbps standards. It performs all the CSMA/CD protocol functions such as transmission, reception, collision handling, etc. The 82551QM CSMA/CD unit communicates with the internal PHY unit through a standard Media Independent Interface (MII), as specified by IEEE 802.3, Chapter 22. This is a 10/100 Mbps mode in which the data stream is nibble-wide and the serial clocks run at either 25 or 2.5 MHz.

5.8.1 Full Duplex

When operating in full duplex mode the 82551QM can transmit and receive frames simultaneously. Transmission starts regardless of the state of the internal receive path. Reception starts when the internal PHY detects a valid frame on the receive differential pair of the PHY.

The 82551QM operates in either half duplex mode or full duplex mode. For proper operation, both the 82551QM CSMA/CD module and the PHY unit must be set to the same duplex mode. The CSMA duplex mode is set by the 82551QM Configure command or forced by the settings in the PHY unit's registers.

The PHY duplex mode is set either by Auto-Negotiation or, if Auto-Negotiation is disabled, by setting the full duplex bit in the Management Data Interface (MDI) Register 0, bit 8. By default, the internal PHY unit advertises full duplex ability in the Auto-Negotiation process regardless of the duplex setting of the CSMA unit. The CSMA configuration should match the result of the Auto-Negotiation.

The selection of duplex operation (full or half) and flow control is done in two levels: MAC and PHY. The MAC duplex selection is done only through the CSMA configuration mechanism (in other words, the Configure command in software).



5.8.2 Flow Control

The 82551QM supports IEEE 802.3x frame-based flow control frames in both full duplex and half duplex switched environments. The 82551QM flow control feature is not intended to be used in shared media environments.

The PHY unit's duplex and flow control enable can be selected using the NWay* Auto-Negotiation algorithm or through the Management Data Interface.

5.8.3 Address Filtering Modifications

The 82551QM can be configured to ignore one bit when checking for its Individual Address (IA) on incoming receive frames. The address bit, known as the Upper/Lower (U/L) bit, is the second least significant bit of the first byte of the IA. This bit may be used, in some cases, as a priority indication bit. When configured to do so, the 82551QM passes any frame that matches all other 47 address bits of its IA, regardless of the U/L bit value.

This configuration only affects the 82551QM specific IA and not multicast, multi-IA or broadcast address filtering. The 82551QM does not attribute any priority to frames with this bit set, it simply passes them to memory regardless of this bit.

5.8.4 VLAN Support

The 82551QM supports the VLAN standard as currently defined by the IEEE 802.1 committee. All VLAN flows will be implemented by software. The 82551QM supports the reception of long frames, specifically frames longer than 1518 bytes, including the CRC, if software sets the Long Receive OK bit in the Configuration command. Otherwise, "long" frames are discarded.

5.9 Media Independent Interface (MII) Management Interface

The MII management interface allows the CPU to control the PHY unit through a control register in the 82551QM. This allows the software driver to place the PHY in specific modes such as full duplex, loopback, power down, etc., without the need for specific hardware pins to select the desired mode. This structure allows the 82551QM to query the PHY unit for status of the link. This register is the MDI Control Register and resides at offset 10h in the 82551QM CSR. (The MDI registers are described in detail in [Section 11.0, "PHY Unit Registers"](#).) The CPU writes commands to this register and the 82551QM reads or writes the control/status parameters to the PHY unit through the MDI register. Although the 82551QM follows the MII format, the MII bus is not accessible on external pins.

6.0 Physical Layer Functional Description

6.1 100BASE-TX PHY Unit

6.1.1 100BASE-TX Transmit Clock Generation

A 25 MHz crystal or a 25 MHz oscillator is used to drive the PHY unit's X1 and X2 pins. The PHY unit derives its internal transmit digital clocks from this crystal or oscillator input. The internal Transmit Clock signal is a derivative of the 25 MHz internal clock. The accuracy of the external crystal or oscillator must be $\pm 0.005\%$ (30 ppm).

6.1.2 100BASE-TX Transmit Blocks

The transmit subsection of the PHY unit accepts nibble-wide data from the CSMA/CD unit. The transmit subsection passes data unconditionally to a 4B/5B encoder.

The 4B/5B encoder accepts nibble-wide data (4 bits) from the CSMA unit and compiles it into 5-bit-wide parallel symbols according to the IEEE 802.3u 100BASE_TX standard. Next, the symbols are scrambled to reduce electromagnetic emissions during long sequences of high-frequency data codes.

The MLT-3 (multi-level signal) encoder receives the scrambled Non-Return to Zero (NRZ) data stream from the scrambler and encodes the stream into MLT-3 for presentation to the driver. MLT-3 is similar to NRZ1 coding, but three levels are output instead of two. The three output levels are positive, negative and zero.

The transmit differential pair line drivers are implemented with digital slope controlled current buffers that meet the TP-PMD specifications. Current is sunk from an isolation transformer by the TDP and TDN pins. The 125 Mbps bit stream is typically driven onto Unshielded Twisted Pair (UTP) cable.

6.1.3 100BASE-TX Receive Blocks

The receive subsection of the PHY unit accepts 100BASE-TX MLT-3 data on the receive differential pair. Due to the advanced digital signal processing design techniques employed, the PHY unit will accurately receive valid data from Category 5 (CAT5) UTP cables of lengths well in excess of 100 meters.

The distorted MLT-3 signal at the end of the wire is restored by the equalizer. The equalizer performs adaptation based on the shape of the received signal. The clock recovery circuit uses digital signal processing to compensate for various signal jitter causes. The circuit recovers the 125 MHz clock and data and presents the data to the MLT-3 decoder.

The PHY unit first decodes the MLT-3 data; afterwards, the descrambler reproduces the 5B symbols originated in the transmitter. The data is decoded at the 4B/5B decoder. After the 4B symbols are obtained, the PHY unit outputs the receive data to the CSMA unit.

In 100BASE-TX mode, the PHY unit can detect errors in receive data in a number of ways, including link integrity failures, undetected start of stream delimiters, invalid symbols, or idles in the middle of a frame.



6.1.4 100BASE-TX Link Integrity Auto-Negotiation

The 82551QM Auto-Negotiation function automatically configures the device to the technology, media, and speed to operate with its link partner. Auto-Negotiation is described in IEEE specification 802.3u, clause 28. The PHY unit supports 10BASE-T half duplex, 10BASE-T full duplex, 100BASE-TX half duplex, and 100BASE-TX full duplex.

Speed and duplex auto-select are functions of Auto-Negotiation. However, these parameters may be manually configured through the MII management interface (MDI registers). Manual configurations override the auto-select.

6.2 10BASE-T PHY Functions

6.2.1 10BASE-T Transmit Clock Generation

The 20 MHz and 10 MHz clocks needed for 10BASE-T are synthesized from the external 25 MHz crystal or oscillator. The PHY unit provides the transmit clock and receive clock to the internal MAC at 2.5 MHz.

6.2.2 10BASE-T Transmit Blocks

After the 2.5 MHz clocked data is serialized in a 10 Mbps serial stream, the 20 MHz clock performs Manchester encoding.

Since 10BASE-T and 100BASE-TX have different filtration needs, both filters are implemented inside the chip. The PHY unit supports both technologies through one pair of TD pins and by externally sharing the same magnetics.

In 10 Mbps mode, the line drivers use a pre-distortion algorithm to improve jitter tolerance. The line drivers reduce their drive level during the second half of “wide” Manchester pulses and maintain a full drive level during narrow pulses and the first half of the wide pulses. This reduces jitter caused by overcharging the line.

6.2.3 10BASE-T Receive Blocks

The PHY unit performs Manchester decoding and timing recovery when in 10 Mbps mode. The Manchester-encoded data stream is decoded from the RD pair to separate Receive Clock and Receive Data from the differential signal. This data is transferred to the CSMA unit at 2.5 MHz/nibble.

In 10 Mbps mode, data is expected to be received on the receive differential pair after passing through isolation transformers. The input differential voltage range capability for the Twisted Pair Ethernet (TPE) receiver is greater than 585 mV and less than 3.1 V. The TPE receive buffer distinguishes valid receive data, link test pulses, and idles, according to the requirements of the 10BASE-T standard.

In 10 Mbps mode, the PHY unit can detect errors in the receive data, including voltage drops prior to the end-of-frame bit. Collision detection in 10 Mbps mode is initiated by simultaneous transmission and reception. If the PHY unit detects this condition, it asserts a collision indication to the CSMA/CD unit.

6.2.4 10BASE-T Link Integrity and Full Duplex

The link integrity in 10 Mbps works with link pulses. The PHY unit senses and differentiates those link pulses from fast link pulses and from 100BASE-TX idles. The link beat pulse is also used to determine if the receive pair polarity is reversed. If it is, the polarity is corrected internally.

The PHY unit supports 10 Mbps full duplex by disabling the collision function, the squelch test, and the carrier sense transmit function. This allows the PHY unit to transmit and receive simultaneously, achieving up to 20 Mbps network bandwidth using Auto-Negotiation. Full duplex can only be used in point-to-point connections (no shared media).

6.3 Auto-Negotiation

The PHY unit supports Auto-Negotiation, which is an automatic configuration scheme designed to manage interoperability in multifunctional LAN environments. An Auto-Negotiation capable device can detect and automatically configure its port to take maximum advantage of common modes of operation without user intervention or prior knowledge by either station. Auto-Negotiation is described in IEEE Standard 802.3u, clause 28.

6.3.1 Description

A PHY's capability is encoded by bursts of link pulses called Fast Link Pulses (FLPs). Connection is established by FLP exchange and handshake during link initialization time. After the link is established by this handshake, the native link pulse scheme resumes. A reset or management re-negotiate command (through the MDI interface) will restart the process. If Auto-Negotiation is unsuccessful, the 82551QM will use Parallel Detection.

The PHY unit supports four technologies: 100BASE-Tx Full and Half Duplex and 10BASE-T Full and Half Duplex. Since only one technology can be used at a time (after every re-negotiate command), a prioritization scheme is used to ensure that the ability of the highest common denominator is chosen.

6.3.2 Parallel Detect and Auto-Negotiation

The PHY unit can automatically determine the speed of the link by using Parallel Detect as an alternative to Auto-Negotiation. Upon a reset, a link status fail, or a negotiate/re-negotiate command, the PHY unit inserts a long delay during which no link pulses are transmitted. This period insures that the PHY unit's link partner has gone into a Link Fail state before Auto-Negotiation or Parallel Detection begins. The PHY unit will look for both FLPs and link integrity pulses. The following diagram illustrates this process.

Figure 11. Auto-Negotiation and Parallel Detect

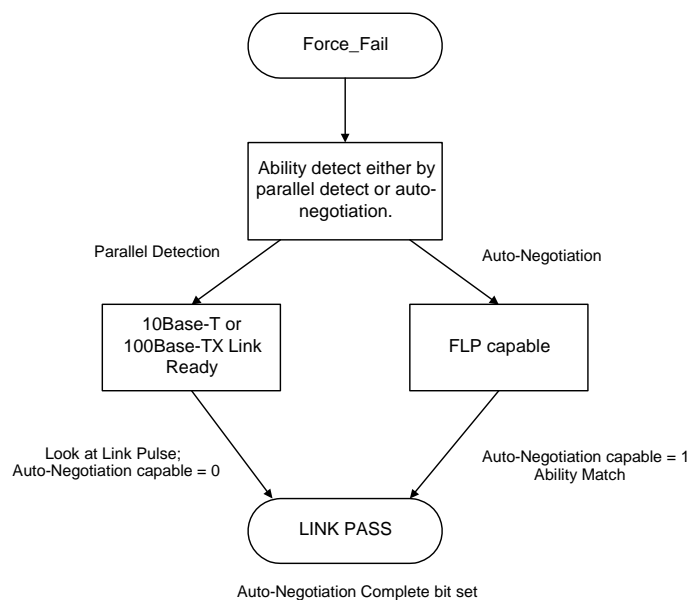

6.4 LED Description

The PHY unit supports three LED pins to indicate link status, network activity and network speed. Each pin can source 10 mA.

- **Link:** This LED is off until a valid link has been detected. After a valid link has been detected, the LED will remain on (active-low).
- **Activity:** This LED blinks on and off when activity is detected on the wire.
- **Speed:** This LED will be on if a 100BASE-TX link is detected and off if a 10BASE-T link is detected. If the link fails while in Auto-Negotiation, this LED will keep the last valid link state. If 100BASE-TX link is forced this LED will be on, regardless of the link status. This LED will be off if the 10BASE-T link is forced, regardless of the link status.

MDI register 27 in [Section 11.3.12, “Register 27: PHY Unit Special Control Register”](#) details the information for LED function mapping and support enhancements.

[Figure 12](#) provides possible schematic diagrams for configurations using two and three LEDs.

Figure 12. Two and Three LED Schematic Diagram

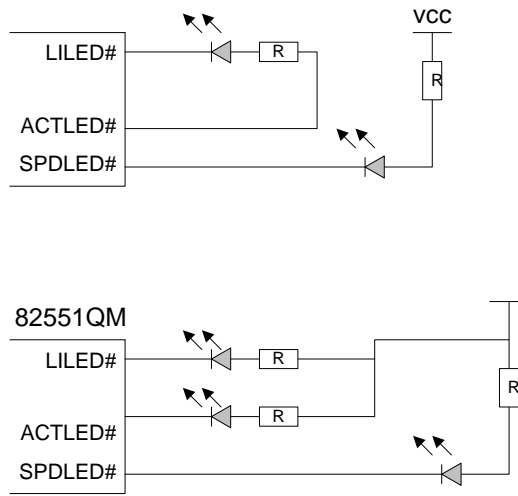



Note: This page intentionally left blank.

7.0 Modem Functionality

The local port mimics the standard 8-bit interface of a modem to the host system and emulates a 16550 Universal Asynchronous Receiver/Transceiver (UART) modem interface. The modem interface includes the following:

- 8-bit data bus: FLD7:0
- Control signals: AEN (FLCS#), MCNTSM# (FLA12), MINT (FLA11), MRING# (FLA10), MRST (FLA9), RD# (FLOE#), and WR# (FLWE#)
- 4 address lines

7.1 PCI Address Mapping to the Modem

The modem can be accessed by the PCI bus through either I/O or memory mapping.

7.2 Modem Read and Write Cycles

Basic read/write cycles to the modem device are shown in the figure below.

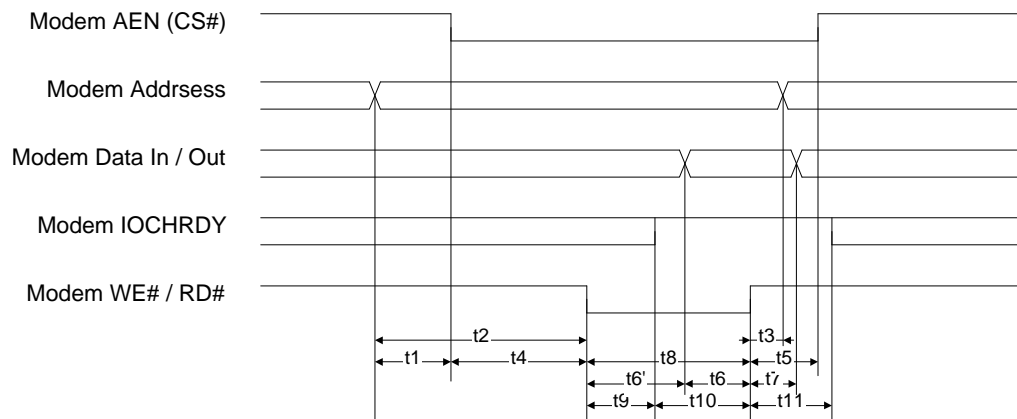

Figure 13. Modem Read/Write Cycles

7.3 Modem and Preboot eXtension Environment Coexistence

The 82551QM local bus can interface with a Flash device or modem without external support. External logic can be implemented on the circuit board to support both devices by using the Modem Chip Select (MDMCS#) and Flash Chip Select (FLCS#) signals.

7.3.1 Programming Details

For designs that use both Flash and modem devices, the 82551QM supports the coexistence of BootROM accesses (for Preboot eXtension Environment [PXE] code) and modem:

1. Set the EEPROM's MDM bit.
2. Clear the BD bit in the EEPROM.

This enables both the modem and boot ROM. This allows the Boot Enable bit in the Expansion BAR to select which external device (modem or Flash) is active on the local bus through the use of the MDMCS# pin. After initialization, the 82551QM enables the Flash on the local bus (in other words, the Boot Enable bit in the BAR equals 1b) and the modem is disabled. Following the execution of the boot code from the Flash device, the enable bit is cleared, and the modem is enabled. The clearing of the Boot Enable bit causes the MDMCS# pin to be asserted, enabling the modem and Function 1 (Modem) Configuration space to be available.

7.3.2 Support Circuitry

An example of support circuitry is shown in [Figure 14](#). When MDMCS# is low, the modem is enabled; MDMCS# is high, the Flash device is enabled.

Figure 14. Support Circuitry Example

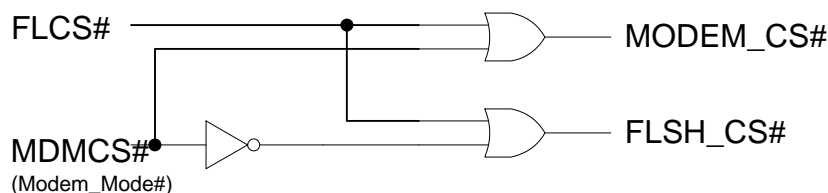



8.0 Manageability Functionality

The 82551QM acts as an SMB slave when receiving alert information and as bus master to collect information.

8.1 Alert Standard Format

The 82551QM supports the Alert Standard Format (ASF) Specification, version 1.0 to monitor the health of systems connected to the network, including desktop, workstation and server systems. Intel's ASF hardware and software enables all systems on the network to report advanced warning and system failure messages to a network management console, in the powered-up, powered-down, and pre-boot state. This data network allows an IT manager to use ASF to remotely perform corrective action on a system.

An example of how ASF adds values to a managed network environment is realized when a system cooling fan fails. The client sends an alert to the network management console. In turn the network IT Manager uses the remote control capabilities of ASF to shut the system down to prevent it from overheating. Another example would be if the operating system hangs. The network manager can re-boot or re-start the system remotely to recover the system. Both of these usages are performed by the IT Manager without leaving his desk.

ASF is based on Intel's Alert on LAN* 2 technology but adds standards-based interfaces and packets. ASF incorporates the System Management Bus, version 2.0 to monitor the system and detect hardware failures. SMB sensors are placed on the motherboard to detect hardware failures that include temperature, fan, and voltage failures. When a failure is detected, ASF requires a Platform Event Trap (PET) packet (for example, SNMP or UDP packet) to be generated to inform the network management console. These bit-based packets are lightweight because they are generated in the powered-down state or boot sequence. In the OS present state, ASF uses the Common Interface Model (CIM) to interact with software components. All warning or failure messages are CIM based.

ASF provides pre-boot Firmware Progress messages and Firmware Error alerts. The Firmware Progress messages detail the progress of the system BIOS as it is running. The firmware error alerts detail hardware failures that the BIOS detects as the system is booting. The Watchdog Timer and the Watchdog Register are used to deliver the alerts to the network management console even if the system fails to boot. The ASF specification supports over twenty-five firmware messages and firmware error alerts.

The system is monitored through SMB sensors, which may push alerts. Otherwise, the 82551QM polls the sensors. When an alert is detected the 82551QM generates a PET compliant packet and sends it to the network management console. Intel's 82551QM implementation also supports Remote Management Control Protocol (RMCP) features such as heartbeat, LAN leash and presence ping/pong, along with the boot path definitions. The heartbeats and LAN leash alerts are supported in both the powered-up and powered-down state.



The 82551QM provides 128 user defined alerts to monitor system hardware. The 82551QM supports SMB, version 2.0 sensors along with eight SMB, version 1.0 sensors as stated in the ASF specification. Some common SMB, version 1.0 sensors available on the market:

- Voltage
- Temperature
- Fan Tach

In addition, Intel's 82551QM includes support for the following remote control operations:

- Presence ping/pong
- System capability request/response
- System state request/response
- Power up
- Unconditional power down
- Reset and power cycle reset
- Boot path definitions
 - NOP
 - Force PXE boot
 - Force hard drive boot
 - Force diagnostic boot
 - Force CD/DVD boot

8.2 Heartbeat

82551QM can be configured to send a heartbeat packet periodically. The heartbeat period (10.7 seconds to 23 minutes) is controlled by the heartbeat timer. Heartbeat and Ping/Pong are mutually exclusive features. 82551QM can also send a heartbeat packet in response to an ICH event.

8.3 Ping/Pong

Upon receiving a “presence ping” packet, 82551QM replies with a “presence pong” packet. Heartbeat and Ping/Pong are mutually exclusive features. This feature can be enabled remotely through a management packet.



8.4 Watchdog

A watchdog packet is sent when the watchdog timer expires. Software can use these registers to indicate the state of the system. For example, the watchdog timer can be set and enabled upon initial power up. If the system hangs before reaching this point, the watchdog timer expires and the 82551QM notifies the management console. When the watchdog timer expires, 82551QM enters Force TCO mode, enables reception of management packets, and sends a watchdog SOS packet if LINK is valid. Because a hard power loss can happen without software knowledge, it is important to disable watchdog events during low power modes. If a hard power loss occurs, an EEPROM load will reload the watchdog timer and possibly set it to be enabled. At the point that PWR_GOOD transitions high, the watchdog timer will become enabled (if configured enabled) and start counting from its initial loaded value, essentially restarting the boot-up time-out timer.

8.5 Advanced Power Management Modes

Upon receiving certain packets, 82551QM can perform Advanced Power Management (APM) transitions such as reset, power-up, and power-down.

8.6 Polling

82551QM acts as a master on the SMB to poll slaves for status, or set APM bits remotely. Target addresses to be polled are stored in the 82551QM's configuration EEPROM.

8.7 Link Loss

If 82551QM detects a link loss for more than 5 seconds, it transmits an alert packet when the link is recovered.

8.8 Acknowledge

Management packets transmitted by 82551QM can be classified in three categories: SOS packets (event notifications), one-shot packets (receive acknowledgments, heartbeats and pongs), and ARP replies. 82551QM can be configured to retransmit each SOS packet a pre-defined number of times at a predefined interval until the SOS packet has been acknowledged. This capability adds reliability to ASF data transfer.



Note: This page intentionally left blank.

9.0 Configuration Registers

The 82551QM acts as both a master and a slave on the PCI bus. As a master, the 82551QM interacts with the system main memory to access data for transmission or deposit received data. As a slave, some 82551QM control structures are accessed by the host CPU to read or write information to the on-chip registers. The CPU also provides the 82551QM with the necessary commands and pointers that allow it to process receive and transmit data.

9.1 Function 0: LAN (Ethernet) PCI Configuration Space

The 82551QM PCI configuration space is configured as 16 Dwords of Type 0 Configuration Space Header, as defined in the PCI Specification, Revision 2.1. A small section is also configured according to its device specific configuration space. The configuration space header is depicted below in Figure 15.

Figure 15. PCI Configuration Registers

Device ID		Vendor ID		00h
Status		Command		04h
Class Code			Revision ID	08h
BIST	Header Type	Latency Timer	Cache Line Size	0Ch
CSR Memory Mapped Base Address Register				10h
CSR I/O Mapped Base Address Register				14h
Flash Memory Mapped Base Address Register				18h
Reserved Base Address Register				1Ch
Reserved Base Address Register				20h
Reserved Base Address Register				24h
Reserved (PCI mode)/CIS Pointer (CardBus mode)				28h
Subsystem ID		Subsystem Vendor ID		2Ch
Expansion ROM Base Address Register				30h
Reserved			Cap_Ptr	34h
Reserved				38h
Max_Lat	Min_Gnt	Interrupt Pin	Interrupt Line	3Ch
Power Management Capabilities		Next Item Ptr	Capability ID	DCh
Reserved	Data	Power Management CSR		E0h

9.1.1 PCI Vendor ID and Device ID Registers

The Vendor ID and Device ID of the 82551QM are both read only word entities. Their values are:

Vendor ID: 8086h

Device ID: 1229h (deskside/server)

Device ID 1059h (mobile)



9.1.2 PCI Command Register

The 82551QM Command register at word address 04h in the PCI configuration space provides control over the 82551QM's ability to generate and respond to PCI cycles. If a 0 is written to this register, the 82551QM is logically disconnected from the PCI bus for all accesses except configuration accesses. The format of this register is shown in the [Figure 16](#).

Figure 16. PCI Command Register

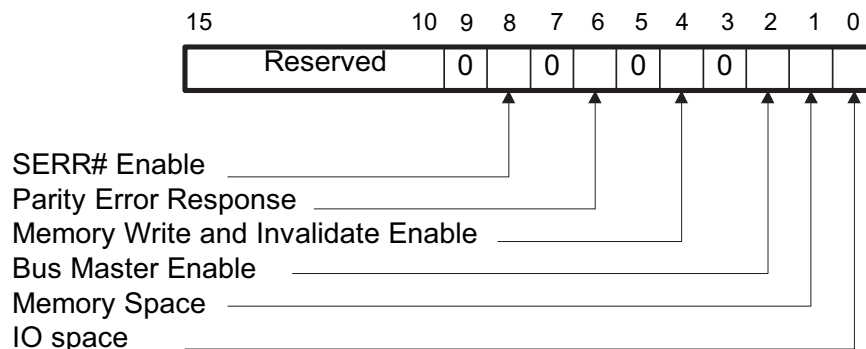

Note: Bits three, five, seven, and nine are set to 0b. The table below lists the bits of the PCI Command register.

Table 15. PCI Command Register Bits

Bits	Name	Description
15:10	Reserved	These bits are reserved and should be set to 0b.
8	SERR# Enable	This bit controls a device's ability to enable the SERR# driver. A value of 0b disables the SERR# driver. A value of 1b enables the SERR# driver. This bit must be set to report address parity errors. In the 82551QM, this bit is configurable and has a default value of 0b.
6	Parity Error Control	This bit controls a device's response to parity errors. A value of 0b causes the device to ignore any parity errors that it detects and continue normal operation. A value of 1b causes the device to take normal action when a parity error is detected. This bit must be set to 0b after RST# is asserted. In the 82551QM, this bit is configurable and has a default value of 0b.
4	Memory Write and Invalidate Enable	This bit controls a device's ability to use the Memory Write and Invalidate command. A value of 0b disables the device from using the Memory Write and Invalidate Enable command. A value of 1b enables the device to use the Memory Write and Invalidate command. In the 82551QM, this bit is configurable and has a default value of 0b.

Table 15. PCI Command Register Bits

Bits	Name	Description
2	Bus Master	This bit controls a device's ability to act as a master on the PCI bus. A value of 0b disables the device from generating PCI accesses. A value of 1b allows the device to behave as a bus master. In the 82551QM, this bit is configurable and has a default value of 0b.
1	Memory Space	This bit controls a device's response to the memory space accesses. A value of 0b disables the device response. A value of 1b allows the device to respond to memory space accesses. In the 82551QM, this bit is configurable and has a default value of 0b.
0	I/O Space	This bit controls a device's response to the I/O space accesses. A value of 0b disables the device response. A value of 1b allows the device to respond to I/O space accesses. In the 82551QM, this bit is configurable and has a default value of 0b.

9.1.3 PCI Status Register

The 82551QM Status register is used to record status information for PCI bus related events. The format of this register is shown in the figure below.

Figure 17. PCI Status Register

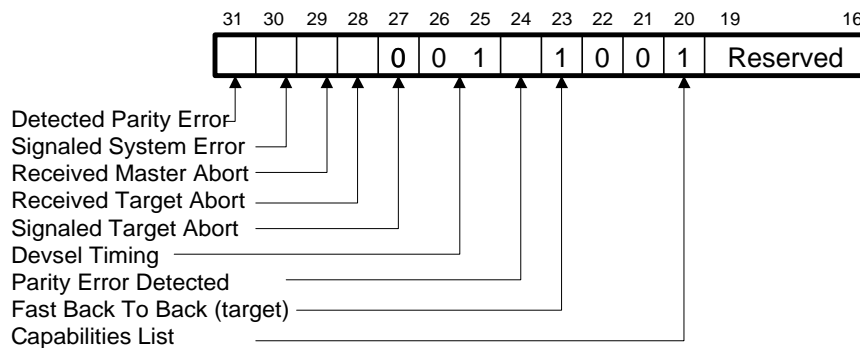

Note: Bits 21, 22, 26, and 27 are set to 0b and bits 20, 23, and 25 are set to 1b. The PCI Status register bits are described in the table below.

Table 16. PCI Status Register Bits

Bits	Name	Description
31	Detected Parity Error	This bit indicates whether a parity error is detected. This bit must be set by the device when it detects a parity error, even if parity error handling is disabled (as controlled by the Parity Error Response bit in the PCI Command register, bit 6). In the 82551QM, the initial value of the Detected Parity Error bit is 0b. This bit is set until cleared by writing a 1b.
30	Signaled System Error	This bit indicates when the device has asserted SERR#. In the 82551QM, the initial value of the Signaled System Error bit is 0b. This bit is set until cleared by writing a 1b.
29	Received Master Abort	This bit indicates whether or not a master abort has occurred. This bit must be set by the master device when its transaction is terminated with a master abort. In the 82551QM, the initial value of the Received Master Abort bit is 0b. This bit is set until cleared by writing a 1b.



Table 16. PCI Status Register Bits

Bits	Name	Description
28	Received Target Abort	This bit indicates that the master has received the target abort. This bit must be set by the master device when its transaction is terminated by a target abort. In the 82551QM, the initial value of the Received Target Abort bit is 0b. This bit is set until cleared by writing a 1b.
27	Signaled Target Abort	This bit indicates whether a transaction was terminated by a target abort. This bit must be set by the target device when it terminates a transaction with target abort. In the 82551QM, this bit is always set to 0b.
26:25	DEVSEL# Timing	These two bits indicate the timing of DEVSEL#: <ul style="list-style-type: none"> 00b - Fast 01b - Medium 10b - Slow 11b - Reserved In the 82551QM, these bits are always set to 1b, medium.
24	Parity Error Detected	This bit indicates whether a parity error has been detected. This bit is set to 1b when the following three conditions are met: <ol style="list-style-type: none"> 1. The bus agent asserted PERR# itself or observed PERR# asserted. 2. The agent setting the bit acted as the bus master for the operation in which the error occurred. 3. The Parity Error Response bit in the command register (bit 6) is set. In the 82551QM, the initial value of the Parity Error Detected bit is 0b. This bit is set until cleared by writing a 1b.
23	Fast Back-to-Back	This bit indicates a device's ability to accept fast back-to-back transactions when the transactions are not to the same agent. A value of 0b disables fast back-to-back ability. A value of 1b enables fast back-to-back ability. In the 82551QM, this bit is read only and is set to 1b.
20	Capabilities List	This bit indicates whether the 82551QM implements a list of new capabilities such as PCI Power Management. A value of 0b means that this function does not implement the Capabilities List. If this bit is set to 1b, the Cap_Ptr register provides an offset into the 82551QM PCI Configuration space pointing to the location of the first item in the Capabilities List. This bit is set only if the power management bit in the EEPROM is set.
19:16	Reserved	These bits are reserved and should be set to 0000b.

9.1.4 PCI Revision ID Register

The Revision ID is an 8-bit read only register. The three least significant bits of the Revision ID can be overridden by the ID and Revision ID fields in the EEPROM (Section 5.7, “Serial EEPROM Interface”). The default value of the Revision ID is 82551QM (A-step): 0Fh

9.1.5 PCI Class Code Register

The Class Code register is read only and is used to identify the generic function of the device and, in some cases, specific register level programming interface. The register is broken into three byte size fields. The upper byte is a base class code and specifies the 82551QM as a network controller, 2h. The middle byte is a subclass code and specifies the 82551QM as an Ethernet controller, 0h. The lower byte identifies a specific register level programming interface and the 82551QM always returns a 0h in this field.

9.1.6 PCI Cache Line Size Register

In order for the 82551QM to support the Memory Write and Invalidate (MWI) command, the 82551QM must also support the Cache Line Size (CLS) register in PCI Configuration space. The register supports only cache line sizes of 8 and 16 Dwords. Any value other than 8 or 16 that is written to the register is ignored and the 82551QM does not use the MWI command. If a value other than 8 or 16 is written into the CLS register, the 82551QM returns all zeroes when the CLS register is read. The figure below illustrates the format of this register.

Figure 18. Cache Line Size Register

7	6	5	4	3	2	1	0
0	0	0	RW	RW	0	0	0

Note: Bit 3 is set to 1b only if the value 00001000b (8h) is written to this register, and bit 4 is set to 1b only if the value of 00010000b (16h) is written to this register. All other bits are read only and will return a value of 0b on read.

The BIOS is expected to write to this register. Therefore, the 82551QM driver should not write to it.

9.1.7 PCI Latency Timer

The Latency Timer register is a byte wide register. When the 82551QM is acting as a bus master, this register defines the amount of time, in PCI clock cycles, that it may own the bus.

9.1.8 PCI Header Type

The Header Type register is a byte read only register. It is equal to 00h for a single function Ethernet card and 80h for a combination Ethernet and modem card. The value of the header type is set by the EEPROM (Section 5.7, “Serial EEPROM Interface”). In a dual function card, the OS will read the next configuration registers bank at offset 100h.

9.1.9 PCI Base Address Registers

One of the most important functions for enabling superior configurability and ease of use is the ability to relocate PCI devices in address spaces. The 82551QM contains three types of Base Address Registers (BARs). Two are used for memory mapped resources, and one is used for I/O mapping. Each register is 32 bits wide. The least significant bit in the BAR determines whether it represents a memory or I/O space. The figures below show the layout of a BAR for both memory and I/O mapping. After determining this information, power-up software can map the memory and I/O controllers into available locations and proceed with system boot. In order to do this mapping



in a device independent manner, the base registers for this mapping are placed in the predefined header portion of configuration space. Device drivers can then access this configuration space to determine the mapping of a particular device.

Figure 19. Base Address Register for Memory Mapping

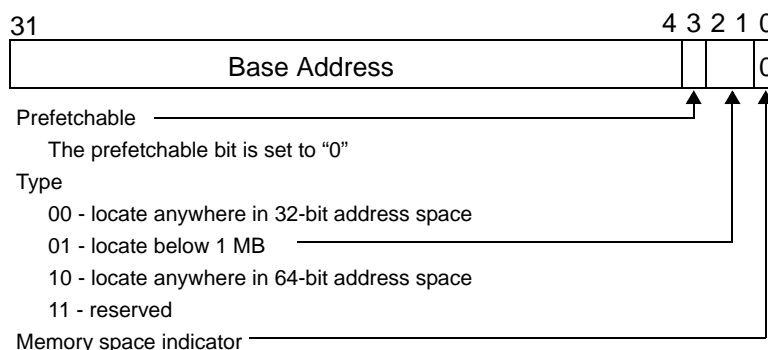
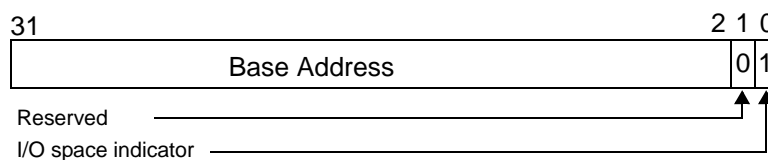

Figure 20. Base Address Register for I/O Mapping



Note: Bit 0 in all base registers is read only and used to determine whether the register maps into memory or I/O space. Base registers that map to memory space must return a 0b in bit 0. Base registers that map to I/O space must return 1b in bit 0.

Base registers that map into I/O space are always 32 bits wide with bit 0 hard-wired to a 1b, bit 1 is reserved and must return 0b on reads, and the other bits are used to map the device into I/O space.

The number of upper bits that a device actually implements depends on how much of the address space the device will respond to. For example, a device that wants a 1 MB memory address space would set the most significant 12 bits of the base address register to be configurable, setting the other bits to 0b.

The 82551QM contains BARs for the Control/Status Register (CSR), Flash, and Expansion ROM.

9.1.9.1 CSR Memory Mapped Base Address Register

The 82551QM requires one BAR for memory mapping. Software determines which BAR, memory or I/O, is used to access the 82551QM CSR registers.

The memory space for the 82551QM CSR Memory Mapped BAR is 4 KB. The space is marked as not prefetchable and is mapped anywhere in the 32-bit memory address space.



9.1.9.2 CSR I/O Mapped Base Address Register

The 82551QM requires one BAR for I/O mapping. Software determines which BAR, I/O or memory, is used to access the 82551QM CSR registers. The I/O space for the 82551QM CSR I/O BAR is 64 bytes.

9.1.9.3 Flash Memory Mapped Base Address Register

The Flash Memory BAR is a Dword register. The 82551QM physically supports a 128 KB Flash device. In a CardBus system, the upper section of the memory mapped window (above the physical Flash device) is used for CIS information. The 82551QM claims a window of 128 KB in CardBus mode and always claims a Flash memory window, regardless of whether or not a Flash device is connected.



9.1.9.4 Expansion ROM Base Address Register

The Expansion ROM has a memory space of 1 MB and its BAR is a Dword register that supports a 128 KB memory via the 82551QM local bus. The Expansion ROM BAR can be disabled by setting the Boot Disable bit located in the EEPROM (word Ah, bit 11). If the Boot Disable bit is set, the 82551QM returns a 0b for all bits in this address register, avoiding request of memory allocation for this space. In LAN/modem combination designs using a Flash device, this bit controls the state of the Modem Chip Select (MDMCS#) pin and is cleared after the initial access of the expansion ROM area. Therefore, in LAN/modem combination designs the MDMCS# pin will be de-asserted (high) when the Boot Disable bit is not set in the EEPROM and the ROM enable bit is set in the Expansion ROM Base Address Register. After the initial access to the Expansion ROM BAR, the Boot Disable bit will be cleared and the MDMCS# signal is asserted (low) enabling the modem to use the local bus.

9.1.10 Base Address Registry Summary

The preceding description of the Base Address Registers' functions are listed in the following table:

Table 17. Base Address Register Functions

Register Name	PCI Function	PCI Window	CardBus Function	CardBus Window
BAR0	Memory CSR	4 KB	Memory CSR	4 KB
BAR1	I/O CSR	4 KB	I/O CSR	4 KB
BAR2	Flash	128 KB	CIS at offset + 64 KB	128 KB
Expansion BAR	BootROM	1 MB	N/A (disabled by EEPROM)	1 MB

9.1.11 CardBus Card Information Structure (CIS) Pointer

The Card Information Structure (CIS) pointer is a Dword hard-coded, read only register. It is meaningful only in a CardBus system (in a PCI system it is zero). The CIS pointer defines where the CIS structure is mapped in the Flash address space.

Table 18. CIS Pointer

Bits	R/W	Default	Description
31:4	R	1000h	Ethernet CIS Pointer (above the physical Flash window)
3:0	R	3h	CIS in the Flash window

9.1.12 PCI Subsystem Vendor ID and Subsystem ID Registers

The Subsystem Vendor ID field identifies the vendor of an 82551QM based solution. The Subsystem Vendor ID values are based upon the vendor's PCI Vendor ID and is controlled by the PCI Special Interest Group (SIG).

The Subsystem ID field identifies the 82551QM based specific solution implemented by the vendor indicated in the Subsystem Vendor ID field.



The 82551QM provides support for configurable Subsystem Vendor ID and Subsystem ID fields. After hardware reset is de-asserted, the 82551QM automatically reads addresses Ah through Ch of the EEPROM. The first of these 16-bit values is used for controlling various 82551QM functions. The second is the Subsystem ID value, and the third is the Subsystem Vendor ID value. Again, the default values for the Subsystem ID and Subsystem Vendor ID are 0h and 0h, respectively.

The 82551QM checks bit numbers 15, 14, and 13 in the EEPROM, word Ah and functions according to [Table 19](#) below.

Table 19. ID Fields Programming

Signature (Bits 15:14)	ID (Bit 13)	AltID (Bit 7)	Device ID	Vendor ID	Revision ID ^a (A-0 and A-1)	Subsystem ID	Subsystem Vendor ID
11b ^b , 10b, 00b	X	X	1229h	8086h	0Fh	0000h	0000h
01b	1b	X	1229h	8086h	Word Ah, bits 10:8	Word Bh	Word Ch
01b	0b	1b	1229h	8086h	0Fh	Word Bh	Word Ch
01b	0b	0b	1229h	8086h	0Fh	Word Bh	Word Ch

- a. The Revision ID is subject to change according to the silicon stepping.
- b. If bit 15 equals 1b, the EEPROM is invalid and the default values are used.

The above table implies that if the 82551QM detects the presence of an EEPROM (as indicated by a value of 1b in bits 15 and 14), then bit number 13 determines whether the values read from the EEPROM, words Bh and Ch, are loaded into the Subsystem ID (word Bh) and Subsystem Vendor ID (word Ch) fields. If bits 15 and 14 equal 1b and bit 13 equals 1b, the three least significant bits of the Revision ID field are programmed by bits 10:8 of the first EEPROM word, Ah.

Between the de-assertion of reset and the completion of the automatic EEPROM read, the 82551QM does not respond to any PCI configuration cycles. If the 82551QM happens to be accessed during this time, it will Retry the access. More information on Retry is provided in [Section 5.2.1.1.3, “Retry Premature Accesses”](#).

9.1.13 Capability Pointer

The Capability Pointer is a hard-coded byte register with a value of DCh. It provides an offset within the Configuration Space for the location of the Power Management registers.

9.1.14 Interrupt Line Register

The Interrupt Line register identifies which system interrupt request line on the interrupt controller the device’s PCI interrupt request pin (as defined in the Interrupt Pin register) is routed to.

9.1.15 Interrupt Pin Register

The Interrupt Pin register is read only and defines which of the four PCI interrupt request pins, INTA# through INTD#, a PCI device is connected to. The 82551QM is connected the INTA# pin.



9.1.16 Minimum Grant Register

The Minimum Grant (Min_Gnt) register is an optional read only register for bus masters and is not applicable to non-master devices. It defines the amount of time the bus master wants to retain PCI bus ownership when it initiates a transaction. The default value of this register for the 82551QM is 08h.

9.1.17 Maximum Latency Register

The Maximum Latency (Max_Lat) register is an optional read only register for bus masters and is not applicable to non-master devices. This register defines how often a device needs to access the PCI bus. The default value of this register for the 82551QM is 18h.

9.1.18 Capability ID Register

The Capability ID is a byte register. It signifies whether the current item in the linked list is the register defined for PCI Power Management. PCI Power Management has been assigned the value of 01h. The 82551QM is fully compliant with the PCI Power Management Specification, Revision 2.2.

9.1.19 Next Item Pointer

The Next Item Pointer is a byte register. It describes the location of the next item in the 82551QM's capability list. Since power management is the last item in the list, this register is set to 0b.

9.1.20 Power Management Capabilities Register

The Power Management Capabilities register is a word read only register. It provides information on the capabilities of the 82551QM related to power management. The 82551QM reports a value of FE21h if it is connected to an auxiliary power source and 7E21h otherwise. It indicates that the 82551QM supports wake-up in the D3 state if power is supplied, either V_{CC} or V_{AUX} .

Table 20. Power Management Capability Register

Bits	Default	Read/Write	Description
31:27	00011b (no V_{AUX}) 11111b (V_{AUX})	Read Only	PME Support. This five-bit field indicates the power states in which the 82551QM may assert PME#. The 82551QM supports wake-up in all power states if it is fed by an auxiliary power supply (V_{AUX}) and D0, D1, D2, and D3 _{hot} if it is fed by PCI power.
26	1b	Read Only	D2 Support. If this bit is set, the 82551QM supports the D2 power state.
25	1b	Read Only	D1 Support. If this bit is set, the 82551QM supports the D1 power state.
24:22	000b	Read Only	Auxiliary Current. This field reports whether the 82551QM implements the Data registers. The auxiliary power consumption is the same as the current consumption reported in the D3 state in the Data register.
21	1b	Read Only	Device Specific Initialization (DSI). The DSI bit indicates whether special initialization of this function is required (beyond the standard PCI configuration header) before the generic class device driver is able to use it. DSI is required for the 82551QM after D3-to-D0 reset.

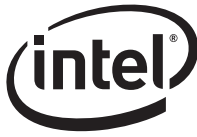

Table 20. Power Management Capability Register

Bits	Default	Read/Write	Description
20	0b (PCI) 1b (CardBus)	Read Only	Reserved (PCI)/Auxiliary Power Source (CardBus). When this bit is set to 1, it indicates that the 82551QM requires auxiliary power supplied by the system for wake-up from the D3 _{cold} state.
19	0b	Read Only	PME Clock. The 82551QM does not require a clock to generate a power management event.
18:16	010b	Read Only	Version. A value of 010b indicates that the 82551QM complies with of the PCI Power Management Specification, Revision 2.2.

9.1.21 Power Management Control/Status Register (PMCSR)

The Power Management Control/Status is a word register. It is used to determine and change the current power state of the 82551QM and control the power management interrupts in a standard manner.

Table 21. Power Management Control and Status Register

Bits	Default	Read/Write	Description
15	0b	Read/Clear	PME Status. This bit is set upon a wake-up event. It is independent of the state of the PME Enable bit. If 1b is written to this bit, the bit will be cleared. It also de-asserts the PME# signal and clears the PME status bit in the Power Management Driver Register. When the PME# signal is enabled, the PME# signal reflects the state of the PME status bit. In a CardBus system, writing a 1b to this bit clears the GWAKE bit in the Function Event register.
14:13	00b	Read Only	Data Scale. This field indicates the data register scaling factor. It equals 10b for registers zero through eight and 00b for registers nine through fifteen.
12:9	0000b	Read Only	Data Select. This field is used to select which data is reported through the Data register and Data Scale field.
8	0b	Read Clear	PME Enable. This bit enables the 82551QM to assert PME#.
7:5	000b	Read Only	Reserved. These bits are reserved and should be set to 000b.
4	0b	Read Only	Dynamic Data. The 82551QM does not support the ability to monitor the power consumption dynamically.
3:2	00b	Read Only	Reserved. These bits are reserved and should be set to 00b.
1:0	00b	Read/Write	Power State. This 2-bit field is used to determine the current power state of the 82551QM and to set the 82551QM into a new power state. The definition of the field values is as follows. 00 - D0 01 - D1 10 - D2 11 - D3



9.1.22 Data Register

The data register is an 8-bit read only register that provides a mechanism for the 82551QM to report state dependent maximum power consumption and heat dissipation. The value reported in this register depends on the value written to the Data Select field in the PMCSR register. The power measurements defined in this register have a dynamic range of 0 to 2.55 W with 0.01 W resolution according to the Data Scale. The value in this register is hard-coded in the silicon. The structure of the data register is listed in Table 22.

Table 22. Ethernet Data Register

Data Select	Data Scale	Data Reported
0	2	D0 Power Consumption = 60 (600 mW)
1	2	D1 Power Consumption = 42 (420 mW)
2	2	D2 Power Consumption = 42 (420 mW)
3	2	D3 Power Consumption = 42 (420 mW)
4	2	D0 Power Dissipated = 60 (60 mW)
5	2	D1 Power Dissipated = 42 (420 mW)
6	2	D2 Power Dissipated = 42 (420 mW)
7	2	D3 Power Dissipated = 42 (420 mW)
8	2	Common Function Power Dissipated = 00
9-15	0	Reserved (00h)

9.2 Function 1: Modem PCI Configuration Space

In PCI and CardBus system, the 82551QM supports a dual function device: LAN/modem. The LAN is defined as function zero, and the modem is defined as function one. The modem function is active depending on the EEPROM setup.

Figure 21. Modem PCI Configuration Registers

Modem Configuration ID			00h	
Modem Status		Modem Command		04h
Modem Revision ID			08h	
BIST	Modem Header Type	Latency Timer	Cache Line Size	0Ch
Modem I/O Mapped Base Address Register			10h	
Modem Memory Mapped Base Address Register			14h	
Reserved Base Address Register			18h	
Reserved Base Address Register			1Ch	
Reserved Base Address Register			20h	
Reserved Base Address Register			24h	
Reserved (PCI mode)/Modem CIS Pointer (CardBus mode)			28h	
Modem Subsystem ID		Modem Subsystem Vendor ID		2Ch
Expansion ROM Base Address Register			30h	
Reserved		Cap_Ptr		34h

Figure 21. Modem PCI Configuration Registers

Reserved			38h
Max_Lat	Min_Gnt	Modem Interrupt	
Modem Power Management Capabilities		Next Item Ptr	Capability ID
Reserved	Modem Data	Modem Power Management CSR	
			3Ch
			DCh
			E0h

The modem configuration registers define the resources required by the modem function. It is meaningful in a multifunction card design only. Some of the modem configuration registers are a reflection of their matched Ethernet registers. The registers' values are pre-defined by hardware, initialized by the EEPROM, or configurable through software. The shaded fields are described in detail in the following subsections.

9.2.1 Modem Configuration ID Register

The Modem Configuration ID field is a Dword register composed of the Device ID and Vendor ID. It is a read only register and its value is loaded from the EEPROM.

9.2.2 Modem Command Register

The Modem Command field is a 16-bit word register and provides basic control over the modem's ability to respond to PCI/CardBus accesses. The Command register's structure is shown in [Table 23](#).

Table 23. Power Management Control and Status Register

Bits	Default	Read/Write	Description
15:10	000000b	Read Only	Reserved. These bits are reserved and should be set to 000000b.
9	0b	Read Only	Fast Back-to-Back.
8	0b	Read/Write	System Error Enable.
7	0b	Read Only	Wait Cycle Enable.
6	0b	Read/Write	Parity Error Enable.
5	0b	Read Only	VGA (define).
4	0b	Read Only	Memory Write and Invalidate.
3	0b	Read Only	Special Cycle.
2	0b	Read Only	Master Enable.
1	0b	Read/Write	Memory Access Enable.
0	0b	Read/Write	I/O Access Enable.



9.2.3 Modem Status Register

The Modem Status field is a 16-bit word register. It provides basic track of CardBus related events. All bits are cleared by RST#.

Table 24. Modem Status Register

Bits	Default	Read/Write	Description
15	0	Read/Write	Parity Error.
14	0	Read/Write	System Error Enable.
13:11	000	Read Only	Signaled/Received Target Abort.
10:9	01	Read Only	Device Select Timing.
8	0	Read Only	Data Parity Detect.
7	0	Read Only	Fast Back-to-Back Capable.
6:5	00	Read Only	Reserved. These bits are reserved and should be set to 00b.
4	1	Read Only	New Capability.
3:0	0000	Read Only	Reserved. These bits are reserved and should be set to 0000b.

9.2.4 Modem Revision ID Register

The Modem Revision ID register is a Dword, read only field. It is composed of the Revision ID byte and a 24-bit Class Code register. Its value is loaded from the EEPROM. The Class Code identifies the function as a modem. The Class Code and Revision ID are listed in [Table 25](#).

Table 25. Modem Revision Register

Bits	Default	Read/Write	Description
31:24	07h	Read Only	Base Class. This indicates that the 82551QM is a communication device.
23:16	00h	Read Only	Subclass. This indicates the serial controller equals 00h.
15:8	02h	Read Only	Program Interface. This indicates that the 82551QM is 16550 UART compatible and initialized by EEPROM word FEh.
7:0	XXH	Read Only	Revision Number. This indicates the revision number and is initialized by EEPROM word FEh.

9.2.5 Modem Header Type Register

The Modem Header Type field is a byte wide, read only register. It indicates that this is a multifunction card and a value of 80h is hard-coded in the silicon.

9.2.6 Modem I/O Base Address Register

The Modem I/O BAR is a Dword register that specifies the I/O base address for accessing the 82551QM's modem. The required I/O space is 8 bytes.



9.2.7 Modem Memory Base Address Register

The Modem Memory BAR is a Dword register that specifies the memory base address for accessing the 82551QM's modem port. The required memory space is 4 KB. The memory space is used for both control registers and CIS mapping.

9.2.8 Modem CardBus CIS Pointer

The CIS pointer is a Dword, hard-coded, read only register. The CIS pointer indicates whether or not the CIS structure is located in the memory address space. The physical location of the CIS structure is in the serial EEPROM. The EEPROM format is described in [Section 5.7, "Serial EEPROM Interface"](#).

Bits	R/W	Default	Description
31:4	R	0010h	Modem CIS Pointer (above the control registers)
3:0	R	2h	CIS in the Memory Base Address Register

9.2.9 Modem Subsystem Vendor ID Register

The Modem Subsystem Vendor ID is a 16-bit read only register. Its value is loaded from the EEPROM and is a reflection of register 2Ch in Function 0, LAN (Ethernet) function.

9.2.10 Modem Subsystem ID Register

The Modem Subsystem ID is a 16-bit, read only register. Its value is loaded from the EEPROM and is a reflection of register 2Eh in Function 0, LAN (Ethernet) function.

9.2.11 Modem Capabilities Pointer

The Modem Capability Pointer is a hard-coded, byte register that contains the value DCh. It provides an offset within the Configuration Space for the location of the power management registers.

9.2.12 Modem Interrupt Register

The Modem Interrupt register specifies whether or not the modem requires an interrupt. This register is hard-coded identically to register 3Ch in Function 0, LAN (Ethernet). It indicates that the modem requires interrupt support.

Note: The modem and Ethernet functions share the same INTA# pin.

9.2.13 Modem Power Management Capabilities Register

The Modem Power Management Capabilities register is a Dword field that indicates if this function has power management capability. It also identifies which power management capabilities are supported. The 82551QM reports a value of FE31h if it is connected to an auxiliary power source; and 7E21h, otherwise.



9.2.14 Modem Power Management Control/Status Register

The Modem Power Management Control/Status Register is a word register. It is used to manage the modem's power management state. It also enables and monitors power management events. The Modem Power Management Control/Status Register structure is identical to register E0h in Function 0, LAN (Ethernet) function.

9.2.15 Modem Data Register

The Modem Data register has similar functionality to register E2h in Function 0, LAN (Ethernet). The register at location E2h reports power consumption of the modem function. The value of power consumption and power dissipation are loaded from the EEPROM.

Table 26. Ethernet Data Register

Data Select	Data Scale	Data Reported
0 - 3	2	D0 to D3 Power Consumption (loaded from EEPROM)
4 - 7	2	D0 to D3 Power Dissipated (loaded from EEPROM)
8 - 15	0	Reserved (00h)

9.2.16 Modem Support in PCI Mode

The 82551QM supports a modem interface in PCI mode. The Modem Enable (MDM) bit in the EEPROM can be activated in PCI systems without the loss of BootROM support. In addition, BootROM support has been simplified. The 82551QM supports the co-existence of a BootRom Flash device and a modem device. This is done by setting the MDM bit and clearing the Boot Disable (BD) bit in the EEPROM. With this configuration, both modem functionality and the BootRom BAR are active. The selection between the two functions is done through Boot Enable bit (the least significant bit of the BootRom BAR in the LAN PCI Configuration space). The 82551QM will not support a LAN/modem design if additional companion ASICs are operating on the Flash/modem interface. This limitation does not affect companion ASICs that reside on the SMB interface of the 82551QM.

10.0 Control/Status Registers

10.1 LAN (Ethernet) Control/Status Registers

The 82551QM's Control/Status Register (CSR) is illustrated in the [Table 22](#).

Figure 22. Control/Status Register

D31	Upper Word	D16	D15	Lower Word	D0	Offset
SCB Command Word			SCB Status Word			00h
System Control Block General Pointer						04h
PORT						08h
EEPROM Control Register			Flash Control Register			0Ch
Management Data Interface (MDI) Control Register						10h
Receive Direct Memory Access Byte Count						14h
PMDR	Flow Control Register			Reserved		18h
Reserved			General Status	General Control		1Ch
Reserved						20h
Command Block Pointer						24h
Reserved						28h
Reserved						2Ch
Function Event Register						30h
Function Event Mask Register						34h
Function Present State Register						38h
Force Event Register						3Ch

NOTE: In [Figure 22](#) above, SCB is defined as the System Control Block of the 82551QM, and PMDR is defined as the Power Management Driver Register.

SCB Status Word: The 82551QM places the status of its Command and Receive units and interrupt indications in this register for the CPU to read.

SCB Command Word: The CPU places commands for the Command and Receive units in this register. Interrupts are also acknowledged in this register.

SCB General Pointer: The SCB General Pointer register points to various data structures in main memory depending on the current SCB Command word.

PORT Interface: The PORT interface allows the CPU to reset the 82551QM, force the 82551QM to dump information to main memory, or perform an internal self test.

Flash Control Register: The Flash Control register allows the CPU to enable writes to an external Flash.

EEPROM Control Register: The EEPROM Control register allows the CPU to read and write to an external EEPROM.



MDI Control Register: The MDI Control register allows the CPU to read and write information from the PHY unit (or an external PHY component) through the Management Data Interface.

Receive DMA Byte Count: The Receive DMA Byte Count register keeps track of how many bytes of receive data have been passed into host memory via DMA.

Flow Control Register: This register holds the flow control threshold value and indicates the flow control commands to the 82551QM.

PMDR: The Power Management Driver Register provides an indication in memory and I/O space that a wake-up interrupt has occurred.

General Control: The General Control register allows the 82551QM to enter the deep power-down state and provides the ability to disable the Clock Run functionality.

General Status: The General Status register describes the status of the 82551QM's duplex mode, speed, and link.

Function Event: The Function Event Register is used for CardBus power management applications and specifies the event that changed the status.

Function Event Mask: The Function Event Mask register masks the CSTSCHG signal assertion for specified events.

Function Present State: The Function Present State register reflects the current state of each condition that may cause a status change or interrupt.

Force Event: The Force Event register simulates the status change events for troubleshooting purposes.

10.1.1 System Control Block Status Word

The System Control Block (SCB) Status Word contains status information relating to the 82551QM's Command and Receive units.

Table 27. System Control Block Status Word

Bits	Name	Description
15	CX	Command Unit (CU) Executed. The CX bit indicates that the CU has completed executing a command with its interrupt bit set.
14	FR	Frame Received. The FR bit indicates that the Receive Unit (RU) has finished receiving a frame.
13	CNA	CU Not Active. The CNA bit is set when the CU is no longer active and in either an idle or suspended state.
12	RNR	Receive Not Ready. The RNR bit is set when the RU is not in the ready state. This may be caused by an RU Abort command, a no resources situation, or set suspend bit due to a filled Receive Frame Descriptor.
11	MDI	Management Data Interrupt. The MDI bit is set when a Management Data Interface read or write cycle has completed. The management data interrupt is enabled through the interrupt enable bit (bit 29 in the Management Data Interface Control register in the CSR).
10	SWI	Software Interrupt. The SWI bit is set when software generates an interrupt.
9	Reserved	This bit is reserved and should be set to 0b.

Table 27. System Control Block Status Word

Bits	Name	Description
8	FCP	Flow Control Pause. The FCP bit is used as the flow control pause bit.
7:6	CUS	Command Unit Status. The CUS field contains the status of the Command Unit.
5:2	RUS	Receive Unit Status. The RUS field contains the status of the Receive Unit.
1:0	Reserved	These bits are reserved and should be set to 0b.

10.1.2 System Control Block Command Word

Commands for the 82551QM's Command and Receive units are placed in this register by the CPU.

Table 28. System Control Block Command Word

Bits	Name	Description
31:26	Specific Interrupt Mask	Specific Interrupt Mask. Setting this bit to 1b causes the 82551QM to stop generating an interrupt (in other words, de-assert the INTA# signal) on the corresponding event.
25	SI	Software Generated Interrupt. Setting this bit to 1b causes the 82551QM to generate an interrupt. Writing a 0b to this bit has no effect.
24	M	Interrupt Mask. If the Interrupt Mask bit is set to 1b, the 82551QM will not assert its INTA# pin. The M bit has higher precedence than the Specific Interrupt Mask bits and the SI bit.
23:20	CUC	Command Unit Command. This field contains the CU command.
19:16	RUC	Receive Unit Command. This field contains the RU command.

10.1.3 System Control Block General Pointer

The System Control Block (SCB) General Pointer is a 32-bit field that points to various data structures depending on the command in the CU Command or RU Command field.

10.1.4 PORT

The PORT interface allows software to perform certain control functions on the 82551QM. This field is 32 bits wide:

- Address and Data (bits 32:4)
- PORT Function Selection (bits 3:0)
The 82551QM supports four PORT commands: Software Reset, Self-test, Selective Reset, and Dump.

10.1.5 Flash Control Register

The Flash Control Register is a 32-bit field that allows access to an external Flash device.



10.1.6 EEPROM Control Register

The EEPROM Control Register is a 32-bit field that enables a read from and a write to the external EEPROM.

10.1.7 Management Data Interface Control Register

The Management Data Interface (MDI) Control register is a 32-bit field and is used to read and write bits from the MDI.

Table 29. MDI Control Register

Bits	Description
31:30	These bits are reserved and should be set to 0b.
29	Interrupt Enable. When this bit is set to 1b by software, the 82551QM asserts an interrupt to indicate the end of an MDI cycle.
28	Ready. This bit is set to 1b by the 82551QM at the end of an MDI transaction. Software should set this bit to 0 at the same time the command is written.
27:26	Opcode. These bits define the opcode: 01 for MDI write and 10 for MDI read. All other values (00 and 11) are reserved.
25:21	PHY Address. This field of bits contains the PHY address.
20:16	PHY Register Address. This field of bits contains the PHY Register Address.
15:0	Data. In a write command, software places the data bits in this field, and the 82551QM transfers the data to the PHY unit. During a read command, the 82551QM reads these bits serially from the PHY unit, and software reads the data from this location.

10.1.8 Receive Direct Memory Access Byte Count

The Receive DMA Byte Count register keeps track of how many bytes of receive data have been passed into host memory via DMA.

10.1.9 Flow Control Register

The Flow Control Register contains the following fields:

- **Flow Control Command**
The Flow Control Command field describes the action of the flow control process (for example, pause, on, or off).
- **Flow Control Threshold**
The Flow Control Threshold field contains the threshold value (in other words, the number of free bytes in the Receive FIFO).



10.1.10 Power Management Driver Register

The 82551QM provides an indication in memory and I/O space that a wake-up event has occurred. It is located in the Power Management Driver (PMDR). The PMDR is used for CardBus mode only.

Table 30. Power Management Driver Register

Bits	Default	Read/Write	Description
31	0b	Read/Clear	Link Status Change Indication. The link status change bit is set following a change in link status and is cleared by writing a 1b to it.
30	0b	Read/Clear	Magic Packet*. This bit is set when a Magic Packet is received regardless of the Magic Packet wake-up disable bit in the configuration command and the PME Enable bit in the Power Management Control/Status Register. This bit is cleared by writing 1b to it.
29	0b	Read/Clear	Interesting Packet. This bit is set when an “interesting” packet is received. Interesting packets are defined by the 82551QM packet filters. This bit is cleared by writing 1b to it.
28	0b	Read Only	Reserved. This bit is reserved and should be set to 0b.
27	0b	Read Only	GCL Enable. This bit is set to 1b when the 82551QM is in GCL mode (in other words, the 82551QM handles management packets). If the GCL Enable bit is set to 0b, the 82551QM does not handle management packets. In this mode, management packets are handled by an external TCO controller.
26	0b	Read/Clear	Force TCO Indication. This bit is reserved for testing.
25	0b	Read/Clear	TCO Request. This bit is set to 1b when the 82551QM is busy with TCO activity.
24	0b	Read/Clear	PME Status. This bit is a reflection of the PME Status bit in the Power Management Control/Status Register (PMCSR). It is set upon a wake-up event and is independent of the PME Enable bit. This bit is cleared by writing 1b to it. This also clears the PME Status bit in the PMCSR and de-asserts the PME signal. In a CardBus system, if 1b is written to this field, the General Wake-up (GWAKE) bit in the Function Event register is cleared.



Note: The PMDR is initialized at ALTRST# reset only.

10.1.11 General Control Register

The General Control register is a byte register and is described below. The General Control register is used in CardBus mode only.

Table 31. General Control Register

Bits	Default	Read/Write	Description
7:2	000000b	Read Only	Reserved. These bits are reserved and should be set to 000000b.
1	0b	Read/Write	Deep Power-Down on Link Down Enable. If a 1b is written to this field, the 82551QM may enter a deep power-down state (sub-3 mA) in the D2 and D3 power states while the link is down. In this state, the 82551QM does not keep link integrity. This state is not supported for point-to-point connection of two end stations.
0	0b	Read/Write	Clock Run Signal Disable. If this bit is set to 1b, then the 82551QM always requests the PCI clock signal. This mode can be used to overcome potential receive overruns caused by Clock Run signal latencies over 5 μ s.

10.1.12 General Status Register

The General Status register is used in CardBus mode only and is a byte register that indicates the link status of the 82551QM.

Table 32. General Status Register

Bits	Default	Read/Write	Description
7:3	00000b	Read Only	Reserved. These bits are reserved and should be set to 00000b.
2	--	Read Only	Duplex Mode. This bit indicates the wire duplex mode: full duplex (1b) or half duplex (0b).
1	--	Read Only	Speed. This bit indicates the wire speed: 100 Mbps (1b) or 10 Mbps (0b).
0	0b	Read Only	Link Status Indication. This bit indicates the status of the link: valid (1b) or invalid (0b).

10.1.13 Ethernet Card Status Change Registers

The PME signal used in PCI systems is replaced by the Card Status Change (CSTSCHG) signal in CardBus systems. The CardBus specification requires the use of control/status registers related to CSTSCHG. There are four event related registers.

1. Function Event Register: Specifies the event that changed status
2. Function Event Mask Register: Masks CSTSCHG signal assertion for specified events
3. Function Present State Register: Reflects the current state of each condition that may cause a status change or interrupt
4. Force Event Register: Simulates status change events for troubleshooting purposes



These CardBus registers are used by software to determine which event has occurred, to manage the event, and to control the CSTSCHG signal.

The 82551QM supports only the interrupt and general wake-up event bits in the card status change registers¹. These registers complement the PCI Power Management registers in a non-ACPI compliant OS. They are initialized by a power-up reset on the ALTRST# pin.

The location of these registers should be specified within the configuration space pointing to offset address 30h of the CSR.

Note: Access to the CSTSCHG registers in PCI mode is not allowed.

10.1.13.1 LAN Function Event Register

The Function Event register specified the event that changed the status.

Table 33. LAN Function Event Register

Bits	Function	Default	Description
31:16	Reserved	0	Bits [31:16] are reserved in the CardBus Specification.
15	INTR	0b	This bit is used for as the interrupt bit. It is set when the Ethernet interrupt source is set, regardless of the mask value. It is cleared when the OS writes 1b to this field and the interrupt source has been serviced. Writing 0b to this field has no effect.
14:5	Reserved	0	Bits [14:5] are reserved in the CardBus Specification.
4	GWAKE	0b	This bit is used for general wake-up. It is set when the Ethernet wake-up source is set, regardless of the mask value. Writing 1b to this field clears this bit and the PME Status bit in the PMCSR. Writing 0b to this field has no effect. Note that writing 1b to the PME Status bit in the PMCSR has the same effect.
3	Reserved	0b	Bit 3 is reserved in the CardBus Specification.
2	Reserved	0b	Reserved.
1	Reserved	0b	Reserved.
0	Reserved	0b	Bit 0 is reserved in the CardBus Specification.

1. For a combination LAN/modem card, the 82551QM implements two independent sets of card status change registers. Each set controls its function separately.



10.1.13.2 LAN Function Event Mask Register

The Function Event Mask register masks CSTSCHG and INTA# assertion.

Table 34. LAN Function Event Mask Register

Bits	Function	Default	Description
31:16	Reserved	0	Bits [31:16] are reserved in the CardBus Specification.
15	INTR	0b	This bit is the interrupt mask. When this bit equals 0b, it masks the Ethernet function INTA# line but has no effect on the LAN Function Event register. The Ethernet function can assert the INTA# signal only when both fields are enabled: the interrupt bit and the "M" bit in the System Control Block (SCB) register within the CSR space. The interrupt mask bit affects the INTA# masking.
14	WKUP	0b	This bit is the wake-up mask. When this bit equals 0b, it masks the Ethernet function CSTSCHG signal but has no effect on the LAN Function Event register. This bit is dependent on bit 4 of this register.
13:7	Reserved	0	Bits [13:7] are reserved in the CardBus Specification.
6:5	PWM BAM	0	These bits are used for Pulse Width Modulation Binary Audio Enable (PWM BAM). Note that the PWM BAM bits are not applicable for LAN.
4	GWAKE	0b	This bit is the general wake-up mask. When this bit equals 0b, it masks the Ethernet function wake-up events towards the CSTSCHG signal. It has no effect on the LAN Function Event register. The 82551QM can assert the CSTSCHG signal in the following configuration of masked bits: wake-up bit AND general wake-up bit, or PME Enable bit in the PMCSR register only.
3	Reserved	0b	Bit 3 is reserved in the CardBus Specification.
2	Reserved	0b	Reserved.
1	Reserved	0b	Reserved.
0	Reserved	0b	Bit 0 is reserved in the CardBus Specification.

10.1.13.3 LAN Function Present State Register

The Function Present State register reflects the current state of the LAN function that may cause a status change or interrupt.

Table 35. LAN Function Present State Register

Bits	Function	Default	Description
31:16	Reserved	0	Bits [31:16] are reserved in the CardBus Specification.
15	INTR	0	This bit is used for interrupts. It reflects the current state of the Ethernet source of the interrupt regardless of the mask value. It is set when the Ethernet function has a pending interrupt and cleared when the software driver acknowledges all active interrupts through the SCB Command Word.
14:5	Reserved	0	Bits [14:5] are reserved in the CardBus Specification.
4	GWAKE	0	This bit is used for general wake-up. It reflects the current state of the Ethernet source of CSTSCHG. It is a logical OR result of the gated three most significant bits in the PMDR: Link Status Change, Magic Packet, and Interesting Packet. The Link Status change bit is gated by the Link Status Change Wake Enable bit in the Configuration command. The Magic Packet bit is gated by the Magic Packet Wake-up disable bit in the Configuration command. The Interesting Packet bit is gated by the programmable filter command.

Table 35. LAN Function Present State Register

Bits	Function	Default	Description
3	Reserved	0b	Bit 3 is reserved in the CardBus Specification.
2	Reserved	0b	Reserved.
1	Reserved	0b	Reserved.
0	Reserved	0b	Bit 0 is reserved in the CardBus Specification.

10.1.13.4 LAN Force Event Register

The Force Event register simulates status change events for troubleshooting purposes. This register provides the ability to simulate events by forcing values into the Function Event register.

Table 36. LAN Force Event Register

Bits	Function	Default	Description
31:16	Reserved	0	Bits [31:16] are reserved in the CardBus Specification.
15	INTR	0	This bit is used for interrupts. Writing 1b in this field will set the interrupt bit in the LAN Function Event register. If the INTA# pin is not masked, then it will also be activated. Writing 0b has no effect.
14:5	Reserved	0	Bits [14:5] are reserved in the CardBus Specification.
4	GWAKE	0	This bit is used for general wake-up. Writing 1b in this field will set the CSTSCHG bit in the LAN Function Event register. If the CSTSCHG pin is not masked, then it will also be activated. Writing 0b has no effect.
3:0	Reserved	0	Bits [3:0] are reserved in the CardBus Specification.

10.2 Statistical Counters

The 82551QM provides information for network management statistics by providing on-chip statistical counters that count a variety of events associated with both transmit and receive. The counters are updated by the 82551QM when it completes the processing of a frame (that is, when it has completed transmitting a frame on the link or when it has completed receiving a frame). The Statistical Counters are reported to the software on demand by issuing the Dump Statistical Counters command or Dump and Reset Statistical Counters command in the SCB Command Unit Command (CUC) field.

Table 37. Statistical Counters

ID	Counter	Description
0	Transmit Good Frames	This counter contains the number of frames that were transmitted properly on the link. It is updated only after the actual transmission on the link is completed, not when the frame was read from memory, as is done for the Transmit Command Block status.
4	Transmit Maximum Collisions (MAXCOL) Errors	This counter contains the number of frames that were not transmitted because they encountered the configured maximum number of collisions.
8	Transmit Late Collisions (LATECOL) Errors	This counter contains the number of frames that were not transmitted due to an encountered collision after the configured slot time.



Table 37. Statistical Counters

ID	Counter	Description
12	Transmit Underrun Errors	A transmit underrun occurs because the system bus cannot keep up with the transmission. This counter contains the number of frames that were either not transmitted or retransmitted due to a transmit DMA underrun. If the 82551QM is configured to retransmit on underrun, this counter may be updated multiple times for a single frame.
16	Transmit Lost Carrier Sense (CRS)	This counter contains the number of frames that were transmitted by the 82551QM despite the fact that it detected the de-assertion of CRS during the transmission.
20	Transmit Deferred	This counter contains the number of frames that were deferred before transmission due to activity on the link.
24	Transmit Single Collisions	This counter contains the number of transmitted frames that encountered one collision.
28	Transmit Multiple Collisions	This counter contains the number of transmitted frames that encountered more than one collision.
32	Transmit Total Collisions	This counter contains the total number of collisions that were encountered while attempting to transmit. This count includes late collisions and frames that encountered MAXCOL.
36	Receive Good Frames	This counter contains the number of frames that were received properly from the link. It is updated only after the actual reception from the link is completed and all the data bytes are stored in memory.
40	Receive CRC Errors	This counter contains the number of aligned frames discarded because of a CRC error. This counter is updated, if needed, regardless of the Receive Unit state. The Receive CRC Errors counter is mutually exclusive of the Receive Alignment Errors and Receive Short Frame Errors counters.
44	Receive Alignment Errors	This counter contains the number of frames that are both misaligned (for example, CRS de-asserts on a non-octal boundary) and contain a CRC error. The counter is updated, if needed, regardless of the Receive Unit state. The Receive Alignment Errors counter is mutually exclusive of the Receive CRC Errors and Receive Short Frame Errors counters.
48	Receive Resource Errors	This counter contains the number of good frames discarded due to unavailability of resources. Frames intended for a host whose Receive Unit is in the No Resources state fall into this category. If the 81551QM is configured to Save Bad Frames and the status of the received frame indicates that it is a bad frame, the Receive Resource Errors counter is not updated.
52	Receive Overrun Errors	This counter contains the number of frames known to be lost because the local system bus was not available. If the traffic problem persists for more than one frame, the frames that follow the first are also lost; however, because there is no lost frame indicator, they are not counted.
56	Receive Collision Detect (CDT)	This counter contains the number of frames that encountered collisions during frame reception.
60	Receive Short Frame Errors	This counter contains the number of received frames that are shorter than the minimum frame length. The Receive Short Frame Errors counter is mutually exclusive to the Receive Alignment Errors and Receive CRC Errors counters. A short frame will always increment only the Receive Short Frame Errors counter.



Table 37. Statistical Counters

ID	Counter	Description
64	Flow Control Transmit Pause	This counter contains the number of Flow Control frames transmitted by the 82551QM. This count includes both the Xoff frames transmitted and Xon (PAUSE(0)) frames transmitted.
68	Flow Control Receive Pause	This counter contains the number of Flow Control frames received by the 82551QM. This count includes both the Xoff frames received and Xon [PAUSE(0)] frames received.
72	Flow Control Receive Unsupported	This counter contains the number of MAC Control frames received by the 82551QM that are not Flow Control Pause frames. These frames are valid MAC control frames that have the predefined MAC control Type value and a valid address but has an unsupported opcode.
76	Receive TCO Frames	This counter contains the number of TCO packets received by the 82551QM.
78	Transmit TCO Frames	This counter contains the number of TCO packets transmitted.

The Statistical Counters are initially set to zero by the 82551QM after reset. They cannot be preset to anything other than zero. The 82551QM increments the counters by internally reading them, incrementing them and writing them back. This process is invisible to the CPU and PCI bus. In addition, the counters adhere to the following rules:

- The counters are wrap-around counters. After reaching FFFFFFFFh the counters wrap around to 0.
- The 82551QM updates the required counters for each frame. It is possible for more than one counter to be updated as multiple errors can occur in a single frame.
- The counters are 32 bits wide and their behavior is fully compatible with the IEEE 802.1 standard. The 82551QM supports all mandatory and recommend statistics functions through the status of the receive header and directly through these Statistical Counters.

The CPU can access the counters by issuing a Dump Statistical Counters SCB command. This provides a “snapshot”, in main memory, of the internal 82551QM statistical counters. The 82551QM supports 21 counters. The dump could consist of either 16 or 21 counters, depending on the status of the Extended Statistics Counters and TCO Statistics configuration bits in the Configuration command.

10.3 Modem Control/Status Registers

Access to modem based memory or I/O ports are mapped to a modem cycle with the lowest 16 addresses of the PCI address space that is mapped to the modem address bus. This is connected to FLA3:0.



10.3.1 Modem Base Memory Addressing

The modem base memory addressing is an 8-byte address space. There are three types of address spaces:

1. Modem chipset address space: 0h to Fh
2. Modem function address space: 80h to FFh (implemented in 82551QM)
3. Modem CIS address space: 100h to 1FFh (loaded from EEPROM)

Table 38. Modem Based Memory Address Registers

Byte Offset	Register Description
0h:7h	Modem controller mimic port, ISA address space 0:7
8h:Fh	Modem controller Resource Management Port (RMP), ISA address space 8:15
80h:83h	Modem Control Register: Reset[0], Central Site Mode[1]
E0h:E3h	Reserved
F0h:F3h	Modem Function Event Register
F4h:F7h	Modem Function Mask Register
F8h:FBh	Modem Function Present Register
FCh:FFh	Modem Force Function Event Register
100h:1FFh	CIS Area (loaded from the EEPROM)

10.3.2 Modem Base I/O Addressing

The modem base I/O addressing is an 8-byte address space. During I/O cycles, accesses to the modem port are byte accesses. FLA3 is kept low while FLA2:0 are mapped according to the PCI byte address offset.

Table 39. Modem Based I/O Address Registers

Byte Offset	Register Description
0h:7h	Venus MIMIC port, ISA address space 7:0.

10.3.3 Modem CardBus CSTCHG Registers

The modem CardBus CSTCHG registers are used in CardBus mode only. There are four event related registers. The CardBus software uses the registers to determine which event has occurred and manage the event and to control the CSTSCHG signal. The 82551QM supports only the interrupt and general wake-up event bits in the CSTSCHG registers. These registers complement the PCI Power Management registers and are used with non-ACPI compliant OS. It is initialized by power-up reset driven on the ALTRST# pin.

10.3.3.1 Modem Function Event Register

The Modem Function Event register specifies the event that changed its status. It is identical to the Ethernet Function Event register described in [Section 10.1.13.1, “LAN Function Event Register”](#).

10.3.3.2 Modem Function Event Mask Register

The Modem Function Event Mask register masks CSTSCHG and INTA# assertion as listed in Table 40.

Table 40. Modem Function Event Mask Register

Bits	Function	Default	Description
31:16	Reserved	0	Bits 31:16 are reserved in the CardBus Specification.
15	INTR	0b	This bit is the interrupt mask. When this bit equals 0b, it masks the modem function INTA# line but has no effect on the Modem Function Event register. The modem function can assert the INTA# signal only when both fields are enabled: the interrupt bit and the modem control bit in the System Control Block (SCB) register within the CSR space. The interrupt mask bit affects the INTA# masking only after the OS has set this register. Thus, on legacy systems that do not access the status change registers, the modem INTA# signal is not masked by the interrupt.
14	WKUP	0b	This bit is the wake-up mask. When this bit equals 0b, it masks the modem function CSTSCHG signal but has no effect on the Function Event register. This bit is dependent on bit 4 of this register.
13:7	Reserved	0	Bits 13:7 are reserved in the CardBus Specification.
6:5	PWM BAM	0	These bits are used for Pulse Width Modulation Binary Audio Enable. (PWM BAM).
4	GWAKE	0b	This bit is the general wake-up mask. When this bit equals 0b, it masks the modem function wake-up events towards the CSTSCHG signal. It has no effect on the Modem Function Event register. The can assert the CSTSCHG signal in the following configuration of masked bits: wake-up bit AND general wake-up bit, or PME Enable bit in the PMCSR register only.
3	Reserved	0b	Bit 3 is reserved in the CardBus Specification.
2	Reserved	0b	Reserved.
1	Reserved	0b	Reserved.
0	Reserved	0b	Bit 0 is reserved in the CardBus Specification.

10.3.3.3 Modem Function Present State Register

The Modem Function Present State register specifies the current state of an event’s sources as listed in Table 41.

Table 41. Modem Function Present State Register

Bits	Function	Default	Description
31:16	Reserved	0	Bits 31:16 are reserved in the CardBus Specification.
15	INTR	0	This bit is used for interrupts. It reflects the current state of the Modem Interrupt (MINT) input pin from the modem.
14:5	Reserved	0	Bits 14:5 are reserved in the CardBus Specification.
4	GWAKE	0	This bit is used for general wake-up. It reflects the current inverse state of the Modem Ring (MRING#) input pin from the modem.
3	Reserved	0b	Bit 3 is reserved in the CardBus Specification.

**Table 41. Modem Function Present State Register**

Bits	Function	Default	Description
2	Reserved	0b	Reserved.
1	Reserved	0b	Reserved.
0	Reserved	0b	Bit 0 is reserved in the CardBus Specification.

10.3.3.4 Modem Force Event Register

The Modem Force Event register simulates status change events for troubleshooting purposes. It is identical to the Ethernet Force Event register described in [Section 10.1.13.4, “LAN Force Event Register”](#).

11.0 PHY Unit Registers

The 82551QM provides status and accepts management information via the Management Data Interface (MDI) within the CSR space.

Acronyms mentioned in the registers are defined as follows:

- SC - self cleared
- RO - read only
- E - EEPROM setting affects content
- LL - latch low
- LH - latch high

11.1 MDI Registers 0 - 7

11.1.1 Register 0: Control Register

Table 42. Register 0: Control

Bit(s)	Name	Description	Default	R/W
15	Reset	This bit sets the status and control register of the PHY to their default states and is self-clearing. The PHY returns a value of one until the reset process has completed and accepts a read or write transaction. 1 = PHY Reset	0	RW SC
14	Loopback	This bit enables loopback of transmit data nibbles from the TXD[3:0] signals to the receive data path. The PHY unit's receive circuitry is isolated from the network. Note that this may cause the descrambler to lose synchronization and produce 560 nanoseconds of "dead time." Note also that the loopback configuration bit takes priority over the Loopback MDI bit. 1 = Loopback enabled 0 = Loopback disabled (Normal operation)	0	RW
13	Speed Selection	This bit controls speed when Auto-Negotiation is disabled and is valid on read when Auto-Negotiation is disabled. 1 = 100 Mbps 0 = 10 Mbps	1	RW
12	Auto-Negotiation Enable	This bit enables Auto-Negotiation. Bits 13 and 8, Speed Selection and Duplex Mode, respectively, are ignored when Auto-Negotiation is enabled. 1 = Auto-Negotiation enabled 0 = Auto-Negotiation disabled	1	RW



Table 42. Register 0: Control

Bit(s)	Name	Description	Default	R/W
11	Power-Down	This bit sets the PHY unit into a low power mode. In low power mode, the PHY unit consumes no more than 30 mA. 1 = Power-Down enabled 0 = Power-Down disabled (Normal operation)	0	RW
10	Reserved	This bit is reserved and should be set to 0b.	0	RW
9	Restart Auto-Negotiation	This bit restarts the Auto-Negotiation process and is self-clearing. 1 = Restart Auto-Negotiation process	0	RW SC
8	Duplex Mode	This bit controls the duplex mode when Auto-Negotiation is disabled. If the PHY reports that it is only able to operate in one duplex mode, the value of this bit shall correspond to the mode which the PHY can operate. When the PHY is placed in Loopback mode, the behavior of the PHY shall not be affected by the status of this bit, bit 8. 1 = Full Duplex 0 = Half Duplex	0	RW
7	Collision Test	This bit will force a collision in response to the assertion of the transmit enable signal. 1 = Force COL 0 = Do not force COL	0	RW
6:0	Reserved	These bits are reserved and should be set to 0b.	0	RW

11.1.2 Register 1: Status Register

Table 43. Register 1: Status

Bit(s)	Name	Description	Default	R/W
15	Reserved	This bit is reserved and should be set to 0b.	0	RO E
14	100BASE-TX Full Duplex	1 = PHY able to perform full duplex 100BASE-TX	1	RO
13	100 Mbps Half Duplex	1 = PHY able to perform half duplex 100BASE-TX	1	RO
12	10 Mbps Full Duplex	1 = PHY able to operate at 10Mbps in full duplex mode	1	RO
11	10 Mbps Half Duplex	1 = PHY able to operate at 10 Mbps in half duplex mode	1	RO
10:7	Reserved	These bits are reserved and should be set to 0b.	0	RO
6	Management Frames Preamble Suppression	0 = PHY will not accept management frames with preamble suppressed	0	RO
5	Auto-Negotiation Complete	1 = Auto-Negotiation process completed 0 = Auto-Negotiation process has not completed	0	RO
4	Remote Fault	0 = No remote fault condition detected	0	RO



Table 43. Register 1: Status

Bit(s)	Name	Description	Default	R/W
3	Auto-Negotiation Ability	1 = PHY is able to perform Auto-Negotiation	1	RO
2	Link Status	1 = Valid link has been established 0 = Invalid link detected	0	RO LL
1	Jabber Detect	1 = Jabber condition detected 0 = No jabber condition detected	0	RO LH
0	Extended Capability	1 = Extended register capabilities enabled	1	RO

11.1.3 Register 2: PHY Identifier Register

Table 44. Register 2: PHY Identifier

Bit(s)	Name	Description	Default	R/W
15:0	PHY ID (high byte)	Value: 02A8h	--	RO

11.1.4 Register 3: PHY Identifier Register

Table 45. Register 3 PHY Identifier

Bit(s)	Name	Description	Default	R/W
15:0	PHY ID (low byte)	Value: 0154h	--	RO

11.1.5 Register 4: Auto-Negotiation Advertisement Register

Table 46. Register 4: Auto-Negotiation Advertisement

Bit(s)	Name	Description	Default	R/W
15	Next Page	Constant 0 = Transmitting primary capability data page	0	RO
14	Reserved	This bit is reserved and should be set to 0b.	0	RO
13	Remote Fault	1 = Indicate link partner's remote fault 0 = No remote fault	0	RW
12:5	Technology Ability Field	Technology Ability Field is an 8-bit field containing information indicating supported technologies specific to the selector field value.	00101111	RW
4:0	Selector Field	The Selector Field is a 5-bit field identifying the type of message to be sent via Auto-Negotiation. This field is read only in the 82551QM and contains a value of 00001b, IEEE Standard 802.3.	00001	RO



11.1.6 Register 5: Auto-Negotiation Link Partner Ability Register

Table 47. Auto-Negotiation Link Partner Ability

Bit(s)	Name	Description	Default	R/W
15	Next Page	This bit reflects the PHY's link partner's Auto-Negotiation ability.	--	RO
14	Acknowledge	This bit is used to indicate that the 82551QM's PHY unit has successfully received its link partner's Auto-Negotiation advertising ability.	--	RO
13	Remote Fault	This bit reflects the PHY's link partner's Auto-Negotiation ability.	--	RO
12:5	Technology Ability Field	This bit reflects the PHY's link partner's Auto-Negotiation ability.	--	RO
4:0	Selector Field	This bit reflects the PHY's link partner's Auto-Negotiation ability.	--	RO

11.1.7 Register 6: Auto-Negotiation Expansion Register

Table 48. Register 6: Auto-Negotiation Expansion

Bit(s)	Name	Description	Default	R/W
15:5	Reserved	These bits are reserved and should be set to 0b.	0	RO
4	Parallel Detection Fault	1 = Fault detected via parallel detection (multiple link fault occurred) 0 = No fault detected via parallel detection This bit will self-clear on read	0	RO SC LH
3	Link Partner Next page Able	1 = Link Partner is Next Page able 0 = Link Partner is not Next Page able	0	RO
2	Next Page Able	1 = Local drive is Next Page able 0 = Local drive is not Next Page able	0	RO
1	Page Received	1 = New Page received 0 = New Page not received This bit will self-clear on read.	0	RO SC LH
0	Link Partner Auto-Negotiation Able	1 = Link Partner is Auto-Negotiation able 0 = Link Partner is not Auto-Negotiation able	0	RO

11.2 MDI Registers 8 - 15

Registers 8 through 15 are reserved for IEEE.

11.3 MDI Register 16 - 31

11.3.1 Register 16: PHY Unit Status and Control Register

Table 49. PHY Unit Status and Control

Bit(s)	Name	Description	Default	R/W
15:14	Reserved	These bits are reserved and should be set to 00b	00	RW
13	Carrier Sense Disconnect Control	This bit enables the disconnect function. 1 = Disconnect function enabled 0 = Disconnect function disabled	0	RW
12	Transmit Flow Control Disable	This bit enables Transmit Flow Control 1 = Transmit Flow Control enabled 0 = Transmit Flow Control disabled	0	RW
11	Receive De-Serializer In-Sync Indication	This bit indicates receipt status of the 100BASE-TX receive de-serializer in-sync.	--	RO
10	100BASE-TX Power-Down	This bit indicates the power state of 100BASE-TX PHY unit. 1 = Power-Down 0 = Normal operation	1	RO
9	10BASE-T Power-Down	This bit indicates the power state of 100BASE-TX PHY unit. 1 = Power-Down 0 = Normal operation	1	RO
8	Polarity	This bit indicates 10BASE-T polarity. 1 = Reverse polarity 0 = Normal polarity	--	RO
7:2	Reserved	These bits are reserved and should be set to 0B.	000000	RO
1	Speed	This bit indicates the Auto-Negotiation result. 1 = 100 Mbps 0 = 10 Mbps	--	RO
0	Duplex Mode	This bit indicates the Auto-Negotiation result. 1 = Full Duplex 0 = Half Duplex	--	RO

11.3.2 Register 17: PHY Unit Special Control Register

Table 50. Register 17: PHY Unit Special Control

Bit(s)	Name	Description	Default	R/W
15	Scrambler By-pass	1 = By-pass Scrambler 0 = Normal operations	0	RW
14	By-pass 4B/5B	1 = 4 bit to 5 bit by-pass 0 = Normal operation	0	RW
13	Force Transmit H-Pattern	1 = Force transmit H-pattern 0 = Normal operation	0	RW

**Table 50. Register 17: PHY Unit Special Control**

Bit(s)	Name	Description	Default	R/W
12	Force 34 Transmit Pattern	1 = Force 34 transmit pattern 0 = Normal operation	0	RW
11	Good Link	1 = 100BASE-TX link good 0 = Normal operation	0	RW
10	Reserved	This bit is reserved and should be set to 0b.	0	RW
9	Transmit Carrier Sense Disable	1 = Transmit Carrier Sense disabled 0 = Transmit Carrier Sense enabled	0	RW
8	Disable Dynamic Power-Down	1 = Dynamic Power-Down disabled 0 = Dynamic Power-Down enabled (normal)	0	RW
7	Auto-Negotiation Loopback	1 = Auto-Negotiation loopback 0 = Auto-Negotiation normal mode	0	RW
6	MDI Tri-State	1 = MDI Tri-state (transmit driver tri-states) 0 = Normal operation	0	RW
5	Filter By-pass	1 = By-pass filter 0 = Normal filter operation	0	RW
4	Auto Polarity Disable	1 = Auto Polarity disabled 0 = Normal polarity operation	0	RW
3	Squelch Disable	1 = 10BASE-T squelch test disable 0 = Normal squelch operation	0	RW
2	Extended Squelch	1 = 10BASE-T Extended Squelch control enabled 0 = 10BASE-T Extended Squelch control disabled	0	RW
1	Link Integrity Disable	1 = Link disabled 0 = Normal Link Integrity operation	0	RW
0	Jabber Function Disable	1 = Jabber disabled 0 = Normal Jabber operation	0	RW

11.3.3 Register 18: PHY Address Register

Table 51. Register 18: PHY Address

Bit(s)	Name	Description	Default	R/W
15:5	Reserved	These bits are reserved and should be set to a constant '0'	0	RO
4:0	PHY Address	These bits are set to the PHY's address, 00001b.	1	RO

11.3.4 Register 19: 100BASE-TX Receive False Carrier Counter

Table 52. Register 19: 100BASE-TX Receive False Carrier Counter

Bit(s)	Name	Description	Default	R/W
15:0	Receive False Carrier	These bits are used for the false carrier counter.	--	RO SC



11.3.5 Register 20: 100BASE-TX Receive Disconnect Counter

Table 53. Register 20: 100BASE-TX Receive Disconnect Counter

Bit(s)	Name	Description	Default	R/W
15:0	Disconnect Event	This field contains a 16-bit counter that increments for each disconnect event. The counter freezes when full and self-clears on read	--	RO SC

11.3.6 Register 21: 100BASE-TX Receive Error Frame Counter

Table 54. Register 21: 100BASE-TX Receive Error Frame Counter

Bit(s)	Name	Description	Default	R/W
15:0	Receive Error Frame	This field contains a 16-bit counter that increments once per frame for any receive error condition (such as a symbol error or premature end of frame) in that frame. The counter freezes when full and self-clears on read.	--	RO SC

11.3.7 Register 22: Receive Symbol Error Counter

Table 55. Register 22: Receive Symbol Error Counter

Bit(s)	Name	Description	Default	R/W
15:0	Symbol Error Counter	This field contains a 16-bit counter that increments for each symbol error. The counter freezes when full and self-clears on read. In a frame with a bad symbol, each sequential six bad symbols count as one.	--	RO SC

11.3.8 Register 23: 100BASE-TX Receive Premature End of Frame Error Counter

Table 56. Register 23: 100BASE-TX Receive Premature End of Frame Error Counter

Bit(s)	Name	Description	Default	R/W
15:0	Premature End of Frame	This field contains a 16-bit counter that increments for each premature end of frame event. The counter freezes when full and self-clears on read.	--	RO SC

11.3.9 Register 24: 10BASE-T Receive End of Frame Error Counter

Table 57. Register 24: 10BASE-T Receive End of Frame Error Counter

Bit(s)	Name	Description	Default	R/W
15:0	End of Frame Counter	This is a 16-bit counter that increments for each end of frame error event. The counter freezes when full and self-clears on read.	--	RO SC



11.3.10 Register 25: 10BASE-T Transmit Jabber Detect Counter

Table 58. Register 25: 10BASE-T Transmit Jabber Detect Counter

Bit(s)	Name	Description	Default	R/W
15:0	Jabber Detect Counter	This is a 16-bit counter that increments for each jabber detection event. The counter freezes when full and self-clears on read.	--	RO SC

11.3.11 Register 26: Equalizer Control and Status Register

Table 59. Register 26: Equalizer Control and Status

Bit(s)	Name	Description	Default	R/W
15:0	RFU	Reserved for Future Use	--	RW

11.3.12 Register 27: PHY Unit Special Control Register

Table 60. Register 27: PHY Unit Special Control

Bit(s)	Name	Description	Default	R/W																											
15:3	Reserved	These bits are reserved and should be set to 0b.	0	RW																											
2:0	LED Switch Control	<table border="1"> <thead> <tr> <th>Value</th> <th>ACTLED#</th> <th>LILED#</th> </tr> </thead> <tbody> <tr> <td>000</td> <td>Activity</td> <td>Link</td> </tr> <tr> <td>001</td> <td>Speed</td> <td>Collision</td> </tr> <tr> <td>010</td> <td>Speed</td> <td>Link</td> </tr> <tr> <td>011</td> <td>Activity</td> <td>Collision</td> </tr> <tr> <td>100</td> <td>Off</td> <td>Off</td> </tr> <tr> <td>101</td> <td>Off</td> <td>On</td> </tr> <tr> <td>110</td> <td>On</td> <td>Off</td> </tr> <tr> <td>111</td> <td>On</td> <td>On</td> </tr> </tbody> </table>	Value	ACTLED#	LILED#	000	Activity	Link	001	Speed	Collision	010	Speed	Link	011	Activity	Collision	100	Off	Off	101	Off	On	110	On	Off	111	On	On	000	RW
Value	ACTLED#	LILED#																													
000	Activity	Link																													
001	Speed	Collision																													
010	Speed	Link																													
011	Activity	Collision																													
100	Off	Off																													
101	Off	On																													
110	On	Off																													
111	On	On																													

11.3.13 Register 28: MDI/MDI-X Control Register

Table 61. Register 28: MDI/MDI-X Control

Bit(s)	Name	Definition	Default	R/W
15:8	Reserved	Reserved for future use. Set these bits to 0.	0	R/W
7	Auto Switch Enable	Enables the MDI/MDI-X feature (writing to this bit overwrites the default value). 1 = Enabled. 0 = Disabled.	0	R/W
6	Switch	Manual switch (valid only if bit 7 is set to 0). 1 = Forces the port to be MDI-X (cross-over). 0 = Forces the port to be MDI (straight-through)	0	R/W
5	Status	Indicates the state of the MDI pair. 1 = MDI-X (cross-over). 0 = MDI (straight-through).	0	RO
4	Auto Switch Complete	Indicates when the correct configuration is achieved. 1 = Resolution algorithm has completed. 0 = Resolution algorithm has not completed.	1	RO
3:0	Resolution Timer	Defines the minimum slot time the algorithm uses in order to switch between one configuration or another. 0000 = 80ms. 1111 = 105ms.	0000	R/W

11.3.14 Register 29: Hardware Integrity Control Register

Table 62. Register 29: Hardware Integrity Control

Bit(s)	Name	Description	Default	R/W
15	HWI Enable	This bit enables the HWI feature causing the PHY unit to enter HWI test mode. 1 = HWI enabled 0 = HWI disabled	0	RW
14	Ability Check	This bit reports the results of the HWI ability check and is valid 100 μ s after the HWI Enabled bit (bit 15 of this register) is set (1b). 1 = Test passed 0 = Test failed (HWI ability not detected)		RO
13	Test Execute	When this bit is set, the PHY unit launches test pulses on the wire to determine the distance to the cable's high or low impedance point. 1 = Execute test 0 = Do not execute test		WO

Table 62. Register 29: Hardware Integrity Control

Bit(s)	Name	Description	Default	R/W
12:11	Reserved	These bits are reserved and should be set to 0b.	00	RO
10:9	LowZ/HighZ	This field of bits indicates either a short (Low Z) or open (high Z) on the line. It is valid 100 μ s after the Test Execute bit (bit 13 of this register) is set. 1 = Short (low Z) 0 = Open (high Z)		RO
8:0	Distance	These bits define the distance to the short or open in the cable and are valid 100 μ s after the Test Execute bit (bit 13 of this register) is set. The distance is defined in granularities of 80 cm (35 inches).		RO



12.0 Electrical and Timing Specifications

Note: This section contains information on products in sampling and early production phase of development. Do not finalize a design with this information. Revised information will be published when the product becomes available.

12.1 Absolute Maximum Ratings

Maximum ratings are listed below:

Ambient Temperature	0° C to 85° C
Storage Temperature	-65° C to 140° C
Outputs and Supply Voltages (except PCI and SMB)	-0.5 V to 5.0 V
PCI and SMB Output Voltages	-0.50 V to 5.25 V
Transmit Data Output Voltage	-0.5 V to 8.0 V
Input Voltages (except PCI and SMB)	-1.0 V to 5.0 V
PCI and SMB Input Voltages	-0.5 V 6.0 V

Note: The 82551IT maximum rating for the Ambient Temperature is -40° C to 85° C.

Stresses above the listed absolute maximum ratings may cause permanent damage to the 82551QM device. This is a stress rating only and functional operations of the device at these or any other conditions above those indicated in the operational sections of this specification is not implied. Exposure to absolute maximum rating conditions for extended periods may affect device reliability.



12.2 DC Specifications

Table 63. General DC Specifications

Symbol	Parameter	Condition	Min	Typical	Max	Units	Notes	
V_{CC}	Supply Voltage		3.0	3.3	3.6	V		
V_{IO}	Peripheral Clamp Voltage	PCI	4.75	5.0	5.25	V	1	
		CardBus	3.0	3.3	3.6	V	1	
I_{CC}	Power Supply (10BASE-T)	D0 _a 10BASE-T full function		85	100	mA	2	
		D1, D2, D3 _{hot} 10BASE-T wake-up enabled		65	75	mA		
		D3 _{cold} 10BASE-T wake-up enabled		40	50	mA		
		D3 _{cold} 10BASE-T wake-up disabled		1.5	2.0	mA		
	Power Supply (100BASE-TX)	D0 _a 100BASE-TX full function			135	155	mA	2
		D1, D2, D3 _{hot} 100BASE-TX wake-up enabled			110	125	mA	
		D3 _{cold} 100BASE-TX wake-up enabled			95	110	mA	
		D3 _{cold} 100BASE-TX wake-up disabled			1.5	2.0	mA	

NOTES:

1. Preferably, V_{IO} should be $5\text{ V} \pm 5\%$ in any PCI environment (either 5 V or 3.3 V signaling). If 5 V is not available in a 3.3 V signaling environment, $3.3\text{ V} \pm 5\%$ may be used instead. In CardBus, V_{IO} must be identical to V_{CC} .
2. Typical current consumption is in nominal operating conditions ($V_{CC} = 3.3\text{ V}$) and average link activity. Maximum current consumption is in maximum V_{CC} and maximum link activity.

The 82551QM supports both the PCI and CardBus interface standards. In the PCI mode, it is five volts tolerant and supports both 5 V and 3.3 V signaling environments.

Table 64. PCI/CardBus Interface DC Specifications

Symbol	Parameter	Condition	Min	Max	Units	Notes
V_{IHP}	Input High Voltage		$0.475V_{CC}$	$V_{IO} + 0.5$	V	
V_{ILP}	Input Low Voltage		-0.5	$0.325V_{CC}$	V	
V_{IPUP}	Input Pull-up Voltage		$0.7V_{CC}$		V	1
V_{IPDP}	Input Pull-down Voltage			$0.2V_{CC}$	V	1
I_{ILP}	Input Leakage Current	$0 < V_{IN} < V_{CC}$		± 10	μA	2
V_{OHP}	Output High Voltage	$I_{out} = -2\text{ mA}$	2.4		V	PCI
		$I_{out} = -500\ \mu\text{A}$	$0.9V_{CC}$		V	
		$I_{out} = -150\ \mu\text{A}$	$0.9V_{CC}$		V	CardBus
V_{OLP}	Output Low Voltage	$I_{out} = 3\text{ mA}, 6\text{ mA}$		0.55	V	3, PCI
		$I_{out} = 1500\ \mu\text{A}$		$0.1V_{CC}$	V	
		$I_{out} = 700\ \mu\text{A}$		$0.1V_{CC}$	V	CardBus
C_{INP}	Input Pin Capacitance			10	pF	4

Table 64. PCI/CardBus Interface DC Specifications

C_{CLKP}	CLK Pin Capacitance		5	12	pF	4
C_{IDSEL}	IDSEL Pin Capacitance			8	pF	4
L_{PINP}	Pin Inductance			20	nH	4
I_{OFFPME}	PME# Input Leakage Current	$V_O < V_{IO}$		1	mA	5

NOTES:

1. These values are only applicable in 3.3 V signaling environments. Outside of this limit the input buffer must consume its minimum current.
2. Input leakage currents include high-Z output leakage for all bidirectional buffers with tristate outputs.
3. Signals without pull-up resistors have 3 mA low output current; and signals requiring pull-up resistors, 6 mA. The signals requiring pull-up resistors include: FRAME#, TRDY#, IRDY#, DEVSEL#, STOP#, SERR# and PERR#.
4. This value is characterized but not tested.
5. This input leakage current is the maximum allowable leakage into the PME# open drain driver when power is removed from V_{CC} of the component. This assumes that no event has occurred to cause the device to assertion of PME#.

Table 65. SMB Interface DC Specifications

Symbol	Parameter	Condition	Min	Max	Units	Notes
V_{IHS}	Input High Voltage		2.1	$V_{IO} + 0.5$	V	1
V_{ILS}	Input Low Voltage		-0.5	0.8	V	1
I_{ILS}	Input Low Leakage Current	$0 < V_{IN} < V_{CC}$		± 5.0	μA	1
V_{OLS}	Output Low Voltage	$I_{PDNS} = 100 \mu A$		0.4	V	1
I_{PDNS}	Current through pull-up resistor		100	350	μA	1, 2

NOTES:

1. SMB outputs (SMB_ALERT#, SMBDATA, and SMBCLK) are open drain.
2. The input leakage current through the pull-up resistor is the maximum allowable leakage into the SMB open drain driver when power is removed from V_{CC} of the component. It assumes that no event has occurred to cause the device to assert SMB.

Table 66. Flash/Modem/EEPROM Interface DC Specifications

Symbol	Parameter	Condition	Min	Max	Units	Notes
V_{IHL}	Input High Voltage		2.0	$V_{CC} + 0.5$	V	
V_{ILL}	Input Low Voltage		-0.5	0.8	V	
I_{ILL}	Input Low Leakage Current	$0 < V_{IN} < V_{CC}$		± 20	μA	
V_{OHL}	Output High Voltage	$I_{out} = -1 \text{ mA}$	2.4		V	
V_{OLL}	Output Low Voltage	$I_{out} = 2 \text{ mA}$		0.4	V	
C_{INL}	Input Pin Capacitance			10	pF	1

NOTE:

1. This value is characterized but not tested.



Table 67. LED Voltage/Current Characteristics

Symbol	Parameter	Condition	Min	Typical	Max	Units	Notes
V _{OHLED}	Output High Voltage	I _{out} = -10 mA	2.4			V	
V _{OLLED}	Output Low Voltage	I _{out} = 10 mA			0.7	V	

Table 68. 100BASE-TX Voltage/Current Characteristics

Symbol	Parameter	Condition	Min	Typical	Max	Units	Notes
R _{ID100}	Input Differential Impedance	DC	10			K Ω	
V _{IDA100}	Input Differential Accept Peak Voltage		± 500			mV	
V _{IDR100}	Input Differential Reject Peak Voltage				± 100	mV	
V _{ICM100}	Input Common Mode Voltage			V _{CC} /2		V	
V _{OD100}	Output Differential Peak Voltage		0.95	1.00	1.05	V	
I _{CCT100}	Line Driver Supply Peak Current	RBIAS100 = 649 Ω		20		mA	1, 2

NOTES:

1. Current is measured on all V_{CC} pins (V_{CC} = 3.3 V). Recommended starting value for RBIAS100.
2. Transmitter peak current is attained by dividing the measured maximum differential output peak voltage by the load resistance value.

Table 69. 10BASE-T Voltage/Current Characteristics

Symbol	Parameter	Condition	Min	Typical	Max	Units	Notes
R _{ID10}	Input Differential Impedance	10 MHz	10			K Ω	
V _{IDA10}	Input Differential Accept Peak Voltage	5 MHz \leq f \leq 10 MHz	± 585	± 440	± 3100	mV	
V _{IDR10}	Input Differential Reject Peak Voltage	5 MHz \leq f \leq 10 MHz	0	± 440	± 300	mV	
V _{ICM10}	Input Common Mode Voltage			V _{CC} /2		V	
V _{OD10}	Output Differential Peak Voltage	R _L = 100 Ω	2.2		2.8	V	
I _{CCT10}	Line Driver Supply Peak Current	RBIAS10 = 619 Ω		20		mA	1, 2

NOTES:

1. Current is measured on all V_{CC} pins (V_{CC} = 3.3 V). Recommended starting value for RBIAS10.
2. Transmitter peak current is attained by dividing the measured maximum differential output peak voltage by the load resistance value.

Table 70. Digital I/O Characteristics

Symbol	Parameter	Min	Typical	Max	Units	Notes
V _{IH}	Output High Voltage	2.0		V _{CC} +0.5	V	
V _{IL}	Output Low Voltage	-0.5		0.8	V	

Table 71. Crystal Input One (X1) Characteristics

Symbol	Parameter	Min	Typical	Max	Units	Notes
V _{IH}	Input High Voltage	2.0		V _{CC} +0.5	V	
V _{IL}	Input Low Voltage	-0.5		0.8	V	

12.3 AC Specifications

Table 72. AC Specifications for PCI Signaling

Symbol	Parameter	Condition	Min	Max	Units	Notes
I _{OH(AC)}	Switching Current High	0 < V _{OUT} ≤ 1.4	-44		mA	1
		1.4 < V _{OUT} < 0.9V _{CC}	-17.1(V _{CC} - V _{OUT})		mA	1
		0.7V _{CC} < V _{OUT} < V _{CC}		Eqn A	mA	2
	(Test Point)	V _{OUT} = 0.7V _{CC}		-32V _{CC}	mA	2
I _{OL(AC)}	Switching Current Low	V _{OUT} ≥ 2.2	95		mA	1
		2.2 > V _{OUT} > 0.1V _{CC}	V _{OUT} /0.023		mA	1
		0.18V _{CC} > V _{OUT} > 0		Eqn B	mA	2
	(Test Point)	V _{OUT} = 0.18V _{CC}		38V _{CC}	mA	2
I _{CL}	Low Clamp Current	-3 < V _{IN} ≤ -1	-25 + (V _{IN} + 1)/0.015		mA	3, 4
I _{CH}	High Clamp Current	V _{CC} + 4 > V _{IN} ≥ V _{CC} + 1	25 + (V _{IN} - V _{CC} - 1)/0.015		mA	3
slew _{RP}	PCI Output Rise Slew Rate	0.4 V to 2.4 V	1	4	V/ns	
slew _{FP}	PCI Output Fall Slew Rate	2.4 V to 0.4 V	1	4	V/ns	

NOTES:

- Switching Current High specifications are not relevant to PME#, SERR#, or INTA#, which are open drain outputs.
- Maximum current requirements will be met as drivers pull beyond the first step voltage (AC drive point). Equations defining these maximums (A and B) are provided. To facilitate component testing, a maximum current test point is defined for each side of the output driver.

Equation A. $I_{OH} = (98/V_{CC}) \cdot (V_{out} - V_{CC}) \cdot (V_{out} + 0.4V_{CC})$, for $V_{CC} > V_{out} > 0.7V_{CC}$

Equation B. $I_{OL} = (256/V_{CC}) \cdot (V_{out}) \cdot (V_{CC} - V_{out})$, for $0 < V_{out} < 0.18V_{CC}$

- This parameter is also applicable to CardBus environment.
- Do not test. Guaranteed by design.

Table 73. AC Specifications for CardBus Signaling

Symbol	Parameter	Condition	Min	Max	Units	Notes
t_{RCB}	CardBus Output Rise Time	$0.2V_{CC}$ to $0.6V_{CC}$	0.25	1.0	V/ns	
t_{FCB}	CardBus Output Fall Time	$0.6V_{CC}$ to $0.2V_{CC}$	0.25	1.0	V/ns	

12.4 Timing Specifications

12.4.1 Clocks Specifications

12.4.1.1 PCI/CardBus Clock Specifications

The 82551QM uses the PCI Clock signal directly. Figure 23 shows the clock waveform and required measurement points for the PCI Clock signal. Table 74 summarizes the PCI Clock specifications.

Figure 23. PCI/CardBus Clock Waveform

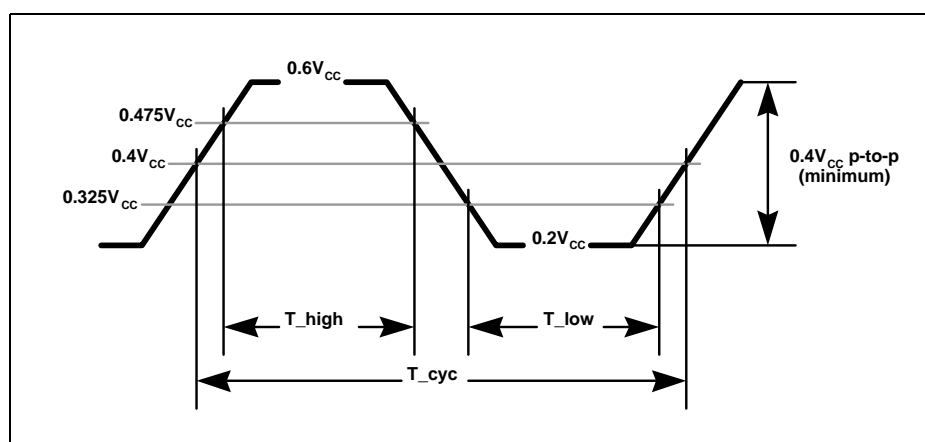

Table 74. PCI/CardBus Clock Specifications

	Symbol	Parameter	Min	Max	Units	Notes
T1	T_{cyc}	CLK Cycle Time	30		ns	1
T2	T_{high}	CLK High Time	11		ns	
T3	T_{low}	CLK Low Time	11		ns	
T4	T_{slew}	CLK Slew Rate	1	4	V/ns	2

NOTES:

1. The 82551QM will work with any PCI clock frequency up to 33 MHz.
2. Rise and fall times are specified in terms of the edge rate measured in V/ns. This slew rate is met across the minimum peak-to-peak portion of the clock waveform as shown in Figure 23.

12.4.1.2 X1 Specifications

X1 serves as a signal input from an external crystal or oscillator. Table 75 defines the 82551QM requirements from this signal.

Table 75. X1 Clock Specifications

	Symbol	Parameter	Min	Typical	Max	Units	Notes
T8	Tx1_dc	X1 Duty Cycle	40%		60%		
T9	Tx1_pr	X1 Period		40		ns	±30PPM

12.4.2 Timing Parameters

12.4.2.1 Measurement and Test Conditions

Figure 24, Figure 25, and Table 76 define the conditions under which timing measurements are done. The component test guarantees that all timings are met with minimum clock slew rate (slowest edge) and voltage swing. The design must guarantee that minimum timings are also met with maximum clock slew rate (fastest edge) and voltage swing. In addition, the design must guarantee proper input operation for input voltage swings and slew rates that exceed the specified test conditions.

Figure 24. Output Timing Measurement Conditions

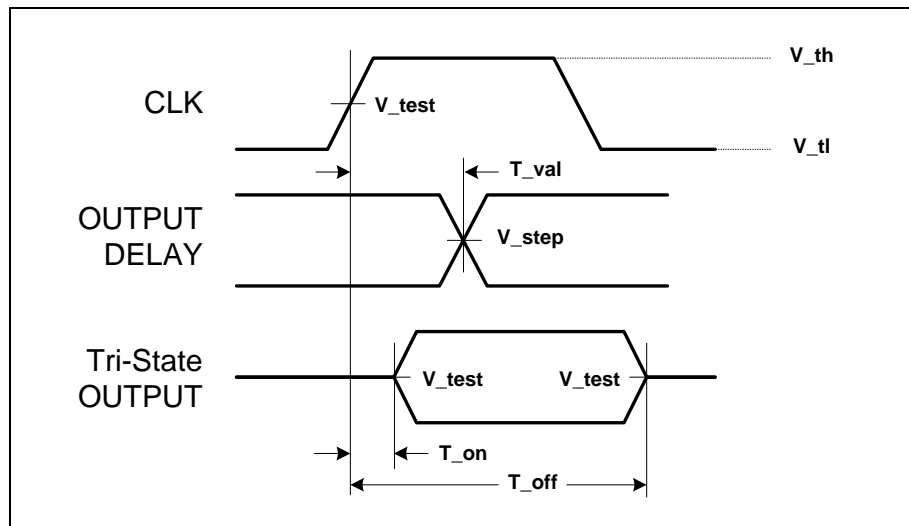

Figure 25. Input Timing Measurement Conditions

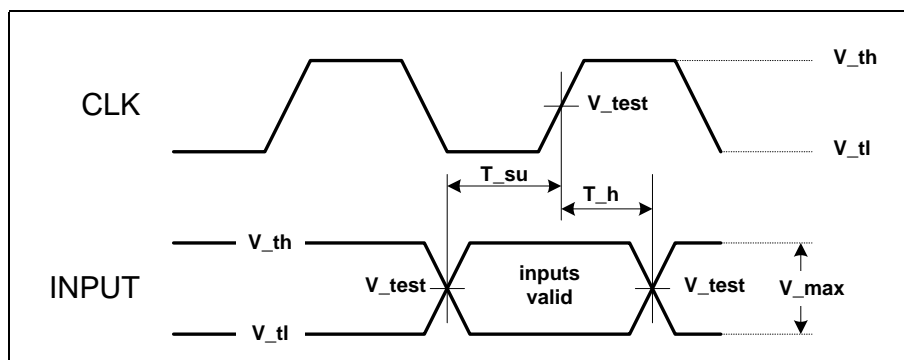

Table 76. Measure and Test Condition Parameters

Symbol	PCI Level	CardBus Level	Units	Notes
V_{th}	$0.6V_{CC}$	$0.6V_{CC}$	V	
V_{tl}	$0.2V_{CC}$	$0.2V_{CC}$	V	
V_{test}	$0.4V_{CC}$	$0.4V_{CC}$	V	
V_{step} (rising edge)	$0.285V_{CC}$	$0.325V_{CC}$	V	Min Delay
		$0.475V_{CC}$	V	Max Delay
V_{step} (falling edge)	$0.615V_{CC}$	$0.475V_{CC}$	V	Min Delay
		$0.325V_{CC}$	V	Max Delay
V_{max}	$0.4V_{CC}$	$0.4V_{CC}$	V	
Input Signal Edge Rate	1	1	V/ns	

NOTE: Input test is done with $0.1V_{CC}$ overdrive. V_{max} specifies the maximum peak-to-peak waveform allowed for testing input timing.

12.4.2.2 PCI/CardBus Timings

Table 77. PCI/CardBus Timing Parameters

	Symbol	Parameter	Min	Max	Units	Notes
T14	t_{val}	PCI CLK to Signal Valid Delay	2	11	ns	1, 2, 3
		CardBus CLK to Signal Valid Delay	2	18	ns	1, 7
T15	$t_{val(ptp)}$	PCI CLK to Signal Valid Delay (point-to-point)	2	12	ns	1, 2, 3
T16	t_{on}	Float to Active Delay	2		ns	1
T17	t_{off}	Active to Float Delay		28	ns	1
T18	t_{su}	Input Setup Time to CLK	7		ns	3, 4
T19	$t_{su(ptp)}$	PCI Input Setup Time to CLK (point-to-point)	10		ns	3, 4
T20	t_h	Input Hold Time from CLK	0		ns	5
T21	t_{rst}	Reset Active Time After Power Stable	1		ms	5
T22	$T_{rst-clk}$	PCI Reset Active Time After CLK Stable	100		clocks	5
		CardBus Reset Active Time After CLK Stable	100		clocks	5
T23	$T_{rst-off}$	Reset Active to Output Float Delay		40	ns	5, 6

NOTES:

1. Timing measurement conditions are illustrated in [Figure 24](#).
2. PCI minimum times are specified with loads as detailed in the PCI Bus Specification, Revision 2.1, Section 4.2.3.2.
3. In a PCI environment, REQ# and GNT# are point-to-point signals and have different output valid delay times and input setup times than bussed signals. All other signals are bussed.
4. Timing measurement conditions are illustrated in [Figure 25](#).
5. RST# is asserted and de-asserted asynchronously with respect to the CLK signal.
6. All PCI and CardBus interface output drivers are floated when RST# is active.
7. CardBus minimum times are specified with a 0 pF equivalent load. Maximum times are specified with a 30 pF equivalent load. Actual test loads may vary but must be correlated to these loads.

12.4.2.3 Flash/Modem Interface Timings

The 82551QM is designed to support up to 150 ns of Flash access time. The V_{pp} signal in the Flash implementation should be connected permanently to 12 V. Thus, writing to the Flash is controlled only by the FLWE# pin.

[Table 78](#) provides the timing parameters for the Flash interface signals. The timing parameters are illustrated in [Figure 26](#) and [Figure 27](#).

Modem is supported through the Flash interface when the following conditions apply:

- FLA6:0, FLD7:0, FLCS#, FLOE#, and FLWE# have the same functions for Flash and modem.



- FLA8 acts as IOCHRDY asynchronous input in modem mode.

Table 78. Flash Timing Parameters

	Symbol	Parameter	Min	Max	Units	Notes
T35	t_{flrwc}	Flash Read/Write Cycle Time	150		ns	1, Flash t_{AVAV} = 150 ns
T36	t_{flacc}	FLA to Read FLD Setup Time	150		ns	1, Flash t_{AVQV} = 150 ns
T37	t_{flce}	FLCS# to Read FLD Setup Time	150		ns	1, Flash t_{ELQV} = 150 ns
T38	t_{floe}	FLOE# Active to Read FLD Setup Time	120		ns	1, Flash t_{GLQV} = 55 ns
T39	t_{fldf}	FLOE# Inactive to FLD Driven Delay Time	50		ns	1, Flash t_{GHQZ} = 35 ns
T40	t_{flas}	FLA Setup Time before FLWE#	5		ns	2, Flash t_{AVWL} = 0 ns
T41	t_{flah}	FLA Hold Time after FLWE#	200		ns	2, Flash t_{WLAX} = 60 ns
T42	t_{flcs}	FLCS# Hold Time before FLWE#	30		ns	2, Flash t_{ELWL} = 20 ns
T43	t_{flch}	FLCS# Hold Time after FLWE#	30		ns	2, Flash t_{WHEH} = 0 ns
T44	t_{flds}	FLD Setup Time	150		ns	2, Flash t_{DVWH} = 50 ns
T45	t_{fldh}	FLD Hold Time	10		ns	2, Flash t_{WHDX} = 10 ns
T46	t_{flwp}	Write Pulse Width	120		ns	2, Flash t_{WLWH} = 60 ns
T47	t_{flwph}	Write Pulse Width High	25		ns	2, Flash t_{WHWL} = 20 ns
T48	t_{Mioha}	IOCHRDY Hold Time after FLWE# or FLOE# Active		25	ns	
T49	t_{Miohi}	IOCHRDY Hold Time after FLWE# or FLOE# Inactive	0		ns	

NOTES:

1. These timing specifications apply to Flash read cycles. The Flash timings referenced are 28F020-150 timings.
2. These timing specifications apply to Flash write cycles. The Flash timings referenced are 28F020-150 timings.

Figure 26. Flash/Modem Timings for a Read Cycle

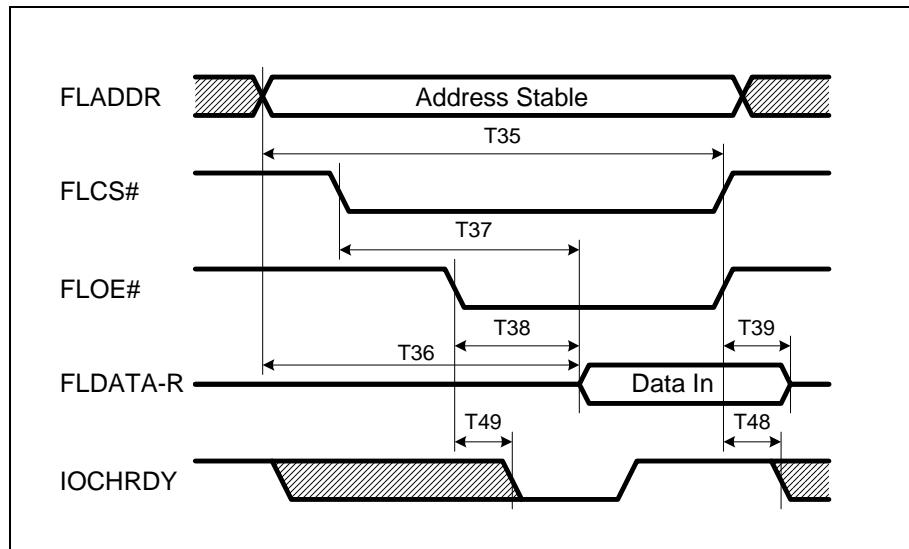
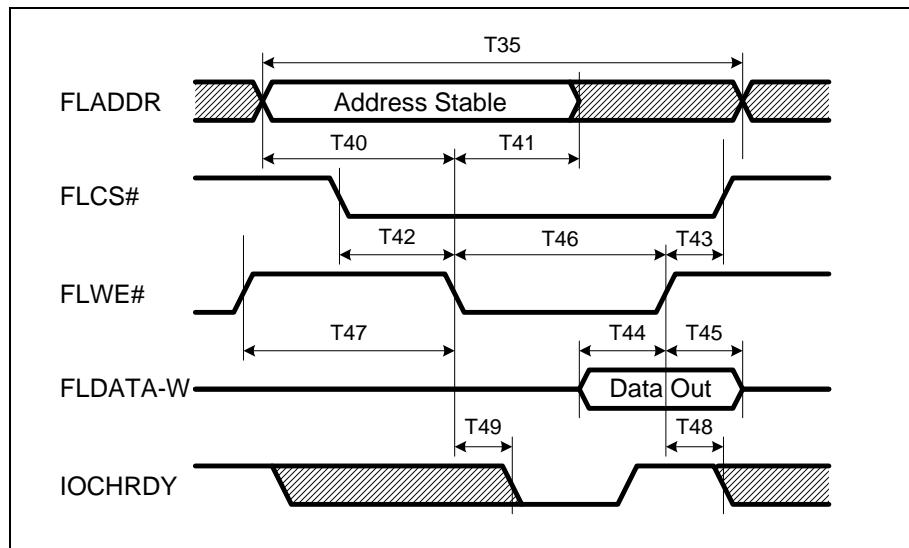

Figure 27. Flash/Modem Timings for a Write Cycle



12.4.2.4 EEPROM Interface Timings

The 82551QM is designed to support a standard 64x16 or 256x16 serial EEPROM. Table 79 provides the timing parameters for the EEPROM interface signals. The timing parameters are illustrated in Figure 28.

Table 79. EEPROM Timing Parameters

	Symbol	Parameter	Min	Max	Units	Notes
T51	t_{ECSS}	Delay from EECS High to EESK High	300		ns	EEPROM tc _{ss} = 50 ns
T52	t_{ECSH}	Delay from EESK Low to EECS Low	30		ns	EEPROM tc _{sh} = 0 ns
T53	t_{EDIS}	Setup Time of EEDI to EESK	300		ns	EEPROM td _{is} = 150 ns
T54	t_{EDIH}	Hold Time of EEDI after EESK	300		ns	EEPROM td _{ih} = 150 ns
T55	t_{ECS}	EECS Low Time	750		ns	EEPROM tc _s = 250 ns

Figure 28. EEPROM Timings

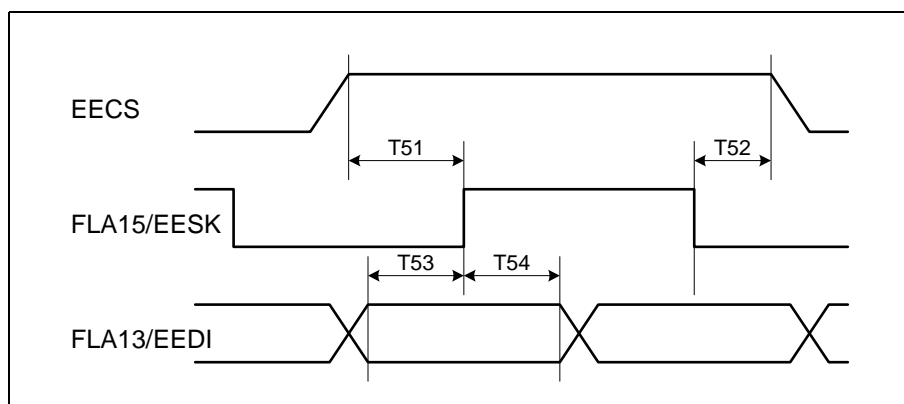

12.4.2.5 PHY Timings

Table 80. 10BASE-T Normal Link Pulse (NLP) Timing Parameters

	Symbol	Parameter	Condition	Min	Typ	Max	Units
T56	T_{nlp_wid}	NLP Width	10 Mbps		100		ns
T57	T_{nlp_per}	NLP Period	10 Mbps	8		24	ms

Figure 29. 10BASE-T Normal Link Pulse (NLP) Timings

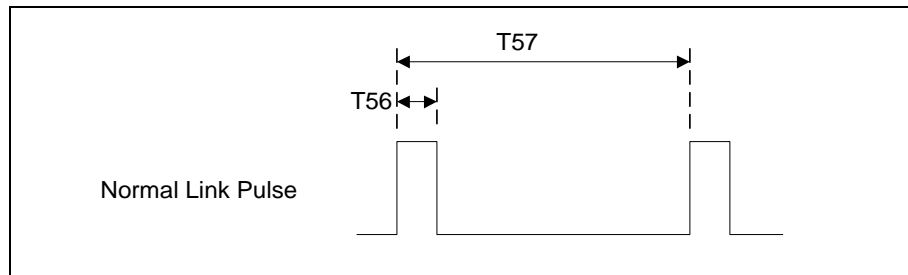

Table 81. Auto-Negotiation Fast Link Pulse (FLP) Timing Parameters

	Symbol	Parameter	Min	Typ	Max	Units
T58	T_{flp_wid}	FLP Width (clock/data)		100		ns
T59	$T_{flp_clk_clk}$	Clock Pulse to Clock Pulse Period	111	125	139	μ s
T60	$T_{flp_clk_dat}$	Clock Pulse to Data Pulse Period	55.5	62.5	69.5	μ s
T61	$T_{flp_bur_num}$	Number of Pulses in one burst	17		33	
T62	$T_{flp_bur_wid}$	FLP Burst Width		2		ms
T63	$T_{flp_bur_per}$	FLP Burst Period	8		24	ms

Figure 30. Auto-Negotiation Fast Link Pulse (FLP) Timings

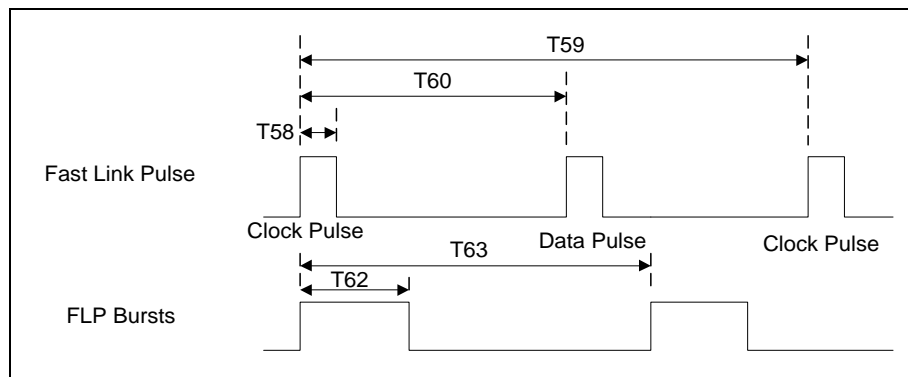



Table 82. 100Base-TX Transmitter AC Specification

	Symbol	Parameter	Condition	Min	Typ	Max	Units
T64	T_{jit}	TDP/TDN Differential Output Peak Jitter	HLS Data			1400	ps

12.4.2.6 SMB Interface Timings

Table 83. Flash Timing Parameters

	Symbol	Parameter	Min	Max	Units	Notes
	f_{smb}	SMB Operating Frequency		1	MHz	
T84	t_{dhs}	Data Hold Time	300		ns	
T85	t_{dsus}	Data Setup Time	250		ns	



13.0 82551QM Test Port Functionality

13.1 Introduction

The 82551QM's XOR Tree Test Access Port (TAP) is the access point for test data to and from the device. The port provides the ability to perform basic production level testing.

13.2 Test Function Description

The 82551QM TAP mode supports two tests that can be used in board level design. These tests help verify basic functionality as well as test the integrity of solder connection on the board. The tests are described in the following subsections.

13.2.1 Tristate

The tristate command sets all 82551QM input and output pins into a tristate (high-Z) mode (all internal pull-ups and pull-downs are disabled). This mode is entered by setting the following test pin combination and resetting the device:

TEST = 1	TEXEC = 0
TCK = 0	TI = 1



13.2.2 XOR Tree

The XOR Tree test mode is the most useful of the asynchronous test modes. It enables the placement of the 82551QM to be validated at board test. The XOR Tree was chosen for its speed advantages. Modern automated test equipment can perform a complete peripheral scan without support at the board level. This command connects all outputs of the input buffers in the device periphery into a XOR Tree scheme. All the output drivers of the output buffers, except the Test Port Data Output (TO) pin, are put into high-Z mode. These pins are driven to affect the output of the tree. There are two separate chains and associated outputs for speed. Any hard strapped pins will prevent the tester from scanning correctly. This mode is entered by placing the test pins in the following combination:

```
TEST = 1           TEXEC = 1
TCK = 0           TI = 1
ISOLATE# = 1
```

Note: ISOLATE# must be driven high in order to enter test mode and must be kept high throughout the entire test.

There are two XOR Tree chains with two separate outputs assigned to FLOE# (Chain 1) and FLWE# (Chain 2).

Table 84. XOR Tree Chains

Chain Order (XOR Tree Output)	Chain 1 (FLOE#)	Chain 2 (FLWE#)
1	RST#	LILED#
2	IDSEL	ACTLED#
3	REQ#	SPDLED#
4	AD[23]	
5	SERR#	
6	AD[22]	
7	AD[21]	
8	AD[20]	ALTRST#
9	AD[19]	CLK_RUN#
10	AD[18]	AD[31]
11	AD[17]	AD[30]
12	C/BE#[2]	AD[29]
13	FRAME#	AD[28]
14	IRDY#	AD[27]
15	TRDY#	PME#
16	CLK	
17	DEVSEL#	AD[26]
18	INTA#	AD[25]
19	STOP#	C/BE#[3]
20	GNT#	AD[24]
21	PERR#	FLD0



Table 84. XOR Tree Chains

Chain Order (XOR Tree Output)	Chain 1 (FLOE#)	Chain 2 (FLWE#)
22	PAR	FLD1
23	AD[16]	FLD2
24	C/BE#[1]	FLD3
25	AD[15]	FLD4
26	AD[14]	FLD5
27	AD[13]	FLD6
28	AD[12]	FLD7
29	AD[11]	FLA0
30	AD[10]	FLA1
31	AD[9]	FLA2
32	AD[8]	FLA3
33	C/BE#[0]	FLA4
34	AD[7]	FLA5
35	AD[6]	FLA6
36	AD[5]	FLA7
37	AD[4]	FLA8
37	AD[3]	FLA9
39	AD[2]	FLA10
40	AD[1]	FLA11
41	AD[0]	FLA12
42	EECS	FLA13/EEDI
43		FLA14/EEDO
44		FLA15/EESK
45		FLA16
46		FLCS#



Note: This page is intentionally left blank.

14.0 Package and Pinout Information

14.1 Package Information

The 82551QM is a 196-pin Ball Grid Array (BGA) package. Package dimensions are shown in [Figure 31](#). More information on Intel® device packaging is available in the Intel Packaging Handbook.

Figure 31. Dimension Diagram for the 196-pin BGA

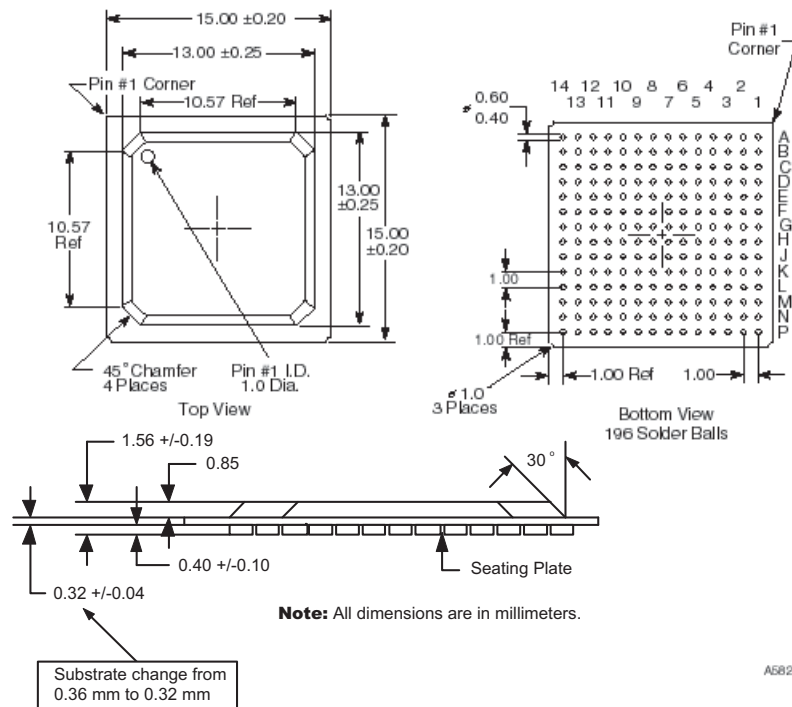

Note: No changes to existing soldering processes are needed for the 0.32 mm substrate change.

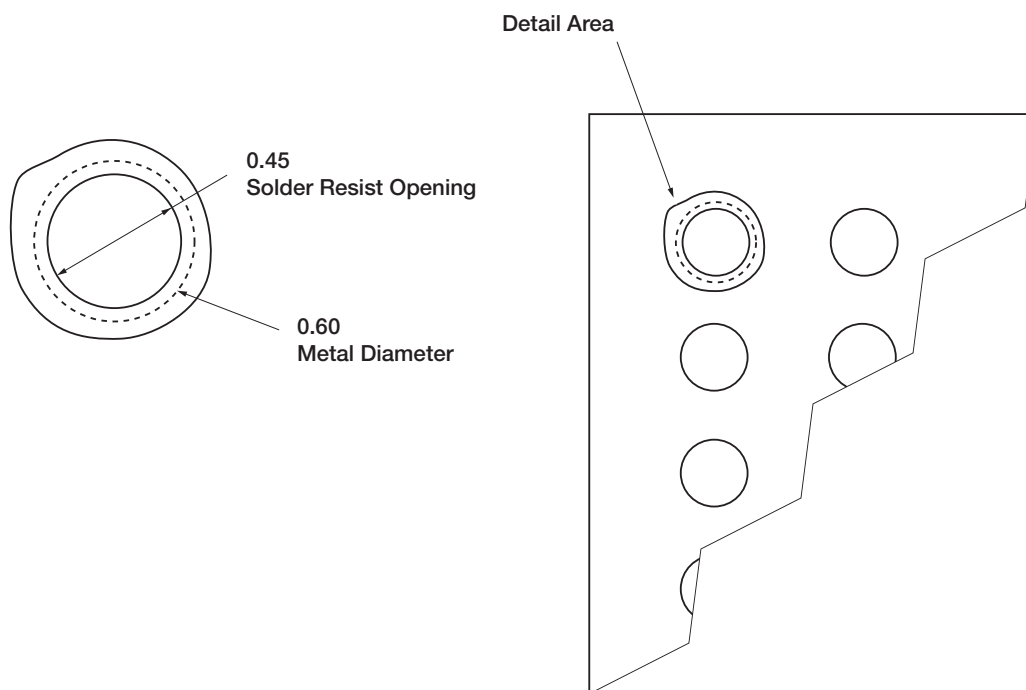
Figure 32. 196 PBGA Package Pad Detail

As illustrated in [Figure 32](#), the 82551QM package uses solder mask defined pads. The copper area is 0.60 mm and the opening in the solder mask is 0.45 mm. The nominal ball sphere diameter is 0.50 mm.



14.2 Pinout Information

14.2.1 Pin Assignments

Table 85. Pin Assignments

Pin	Name	Pin	Name	Pin	Name
A1	NC	A2	SERR#	A3	VCC
A4	IDSEL	A5	AD[25]	A6	PME#
A7	VCC	A8	AD[30]	A9	ALTRST#
A10	SMBCLK	A11	VCC	A12	LILED#
A13	TEST	A14	NC		
B1	AD[22]	B2	AD[23]	B3	VSSPP
B4	AD[24]	B5	AD[26]	B6	AD[27]
B7	VSSPP	B8	AD[31]	B9	ISOLATE#
B10	SMB_ALERT#/ LAN_PWR_ GOOD	B11	SPDLED#	B12	TO
B13	RBIAS100	B14	RBIAS10		
C1	AD[21]	C2	RST#	C3	REQ#
C4	C/BE#[3]	C5	CSTSCHG	C6	AD[28]
C7	AD[29]	C8	CLK_RUN#	C9	SMBDATA
C10	VSSPT	C11	ACTLED#	C12	VREF
C13	TDP	C14	TDN		
D1	AD[18]	D2	AD[19]	D3	AD[20]
D4	VSS	D5	VSS	D6	VSS
D7	VSS	D8	VSS	D9	NC
D10	NC	D11	NC	D12	TI
D13	TEXEC	D14	TCK		
E1	VCC	E2	VSSPP	E3	AD[17]
E4	VSS	E5	VSS	E6	VSS
E7	VSS	E8	VSS	E9	VSS
E10	VSS	E11	NC	E12	VCC
E13	RDP	E14	RDN		
F1	IRDY#	F2	FRAME#	F3	C/BE#[2]
F4	VSS	F5	VSS	F6	VSS
F7	VSS	F8	VSS	F9	VSS
F10	VSS	F11	VSS	F12	FLD2
F13	FLD1	F14	FLD0		
G1	CLK	G2	VIO	G3	TRDY#
G4	NC	G5	VCC	G6	VCC
G7	VSS	G8	VSS	G9	VSS



Table 85. Pin Assignments

Pin	Name	Pin	Name	Pin	Name
G10	VSS	G11	VSS	G12	FLD3
G13	VCC	G14	VSSPL		
H1	STOP#	H2	INTA#	H3	DEVSEL#
H4	NC	H5	VCC	H6	VCC
H7	VCC	H8	VCC	H9	VSS
H10	VSS	H11	NC	H12	FLD6
H13	FLD5	H14	FLD4		
J1	PAR	J2	PERR#	J3	GNT#
J4	NC	J5	VCC	J6	VCC
J7	VCC	J8	VCC	J9	VCC
J10	VCCR	J11	VCCR	J12	FLA1
J13	FLA0	J14	FLD7		
K1	AD[16]	K2	VSSPP	K3	VCC
K4	VCC	K5	VCC	K6	VCC
K7	VCC	K8	VCC	K9	VCC
K10	VCC	K11	VCC	K12	VSSPL
K13	VCC	K14	FLA2		
L1	AD[14]	L2	AD[15]	L3	C/BE#[1]
L4	VCC	L5	VCC	L6	VSS
L7	MDMCS#	L8	NC	L9	VCC
L10	VCC	L11	VSS	L12	FLA5
L13	FLA4	L14	FLA3		
M1	AD[11]	M2	AD[12]	M3	AD[13]
M4	C/BE#[0]	M5	AD[5]	M6	VSSPP
M7	AD[1]	M8	FLOE#	M9	FLWE#
M10	FLA15/EESK	M11	FLA12	M12	FLA11
M13	FLA7	M14	FLA6		
N1	VSSPP	N2	AD[10]	N3	AD[9]
N4	AD[7]	N5	AD[4]	N6	VCC
N7	AD[0]	N8	VCC	N9	FLCS#
N10	FLA14/EEDO	N11	X1	N12	VSSPL
N13	FLA10	N14	FLA8/IOCHRDY		
P1	NC	P2	VCC	P3	AD[8]
P4	AD[6]	P5	AD[3]	P6	AD[2]
P7	EECS	P8	VSSPL	P9	FLA16
P10	FLA13/EEDI	P11	X2	P12	VCC
P13	FLA9	P14	NC		



14.2.2 Ball Grid Array Diagram

Figure 33. Ball Grid Array Diagram

	A	B	C	D	E	F	G	H	J	K	L	M	N	P
1	NC	AD[22]	AD[21]	AD[18]	VCC	IRDY#	CLK	STOP#	PAR	AD[16]	AD[14]	AD[11]	VSSPP	NC
2	SERR#	AD[23]	RST#	AD[19]	VSSPP	FRAME#	VIO	INTA#	PERR#	VSSPP	AD[15]	AD[12]	AD[10]	VCC
3	VCC	VSSPP	REQ#	AD[20]	AD[17]	C/BE#[2]	TRDY#	DVSEL#	GNT#	VCC	C/B3#[1]	AD[13]	AD[9]	AD[8]
4	IDSEL	AD[24]	C/BE#[3]	VSS	VSS	VSS	NC	NC	NC	VCC	VCC	C/BE#[0]	AD[7]	AD[6]
5	AD[25]	AD[26]	CSTSCHG	VSS	VSS	VSS	VCC	VCC	VCC	VCC	VCC	AD[5]	AD[4]	AD[3]
6	PME#	AD[27]	AD[28]	VSS	VSS	VSS	VCC	VCC	VCC	VCC	VSS	VSSPP	VCC	AD[2]
7	VCC	VSSPP	AD[29]	VSS	VSS	VSS	VSS	VCC	VCC	VCC	MDMCS#	AD[1]	AD[0]	EECS
8	AD[30]	AD[31]	CLK_RUN#	VSS	VSS	VSS	VSS	VCC	VCC	VCC	NC	FLOE#	VCC	VSSPL
9	ALTRST#	ISOLATE#	SMBDATA	NC	VSS	VSS	VSS	VSS	VCC	VCC	VCC	FLWE#	FLCS#	FLA16
10	SMBCLK	SMB_ALERT#/ LAN_PWR_GOOD	VSSPT	NC	VSS	VSS	VSS	VSS	VCCR	VCC	VCC	FLA15/ EESK	FLA14/ EEDO	FLA13/ EEDI
11	VCC	SPDLED#	ACTLED#	NC	NC	VSS	VSS	NC	VCCR	VCC	VSS	FLA12	X1	X2
12	LILED#	TO	VREF	TI	VCC	FLD2	FLD3	FLD6	FLA1	VSSPL	FLA5	FLA11	VSSPL	VCC
13	TEST	RBIAS_100	TDP	TEXEC	RDP	FLD1	VCC	FLD5	FLA0	VCC	FLA4	FLA7	FLA10	FLA9
14	NC	RBIAS_10	TDN	TCK	RDN	FLD0	VSSPL	FLD4	FLD7	FLA2	FLA3	FLA6	FLA8/ IOCHRDY	NC



15.0 Reference Schematics

This section shows a 10/100 Mbps design using the 82551QM Fast Ethernet Multifunction PCI/ CardBus Controller.

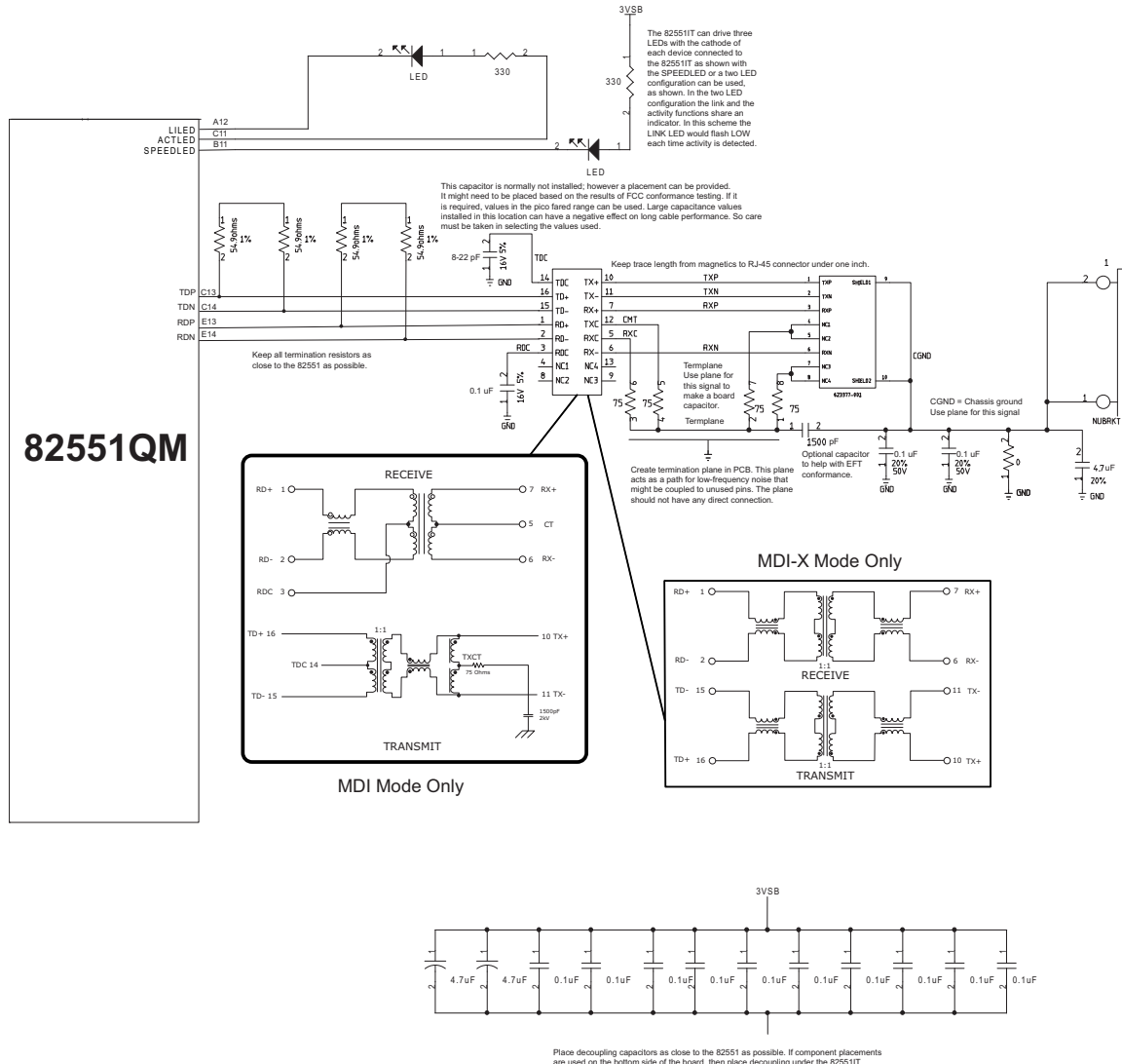

Figure 34. Reference Schematic Layout (Sheet 1 of 2)

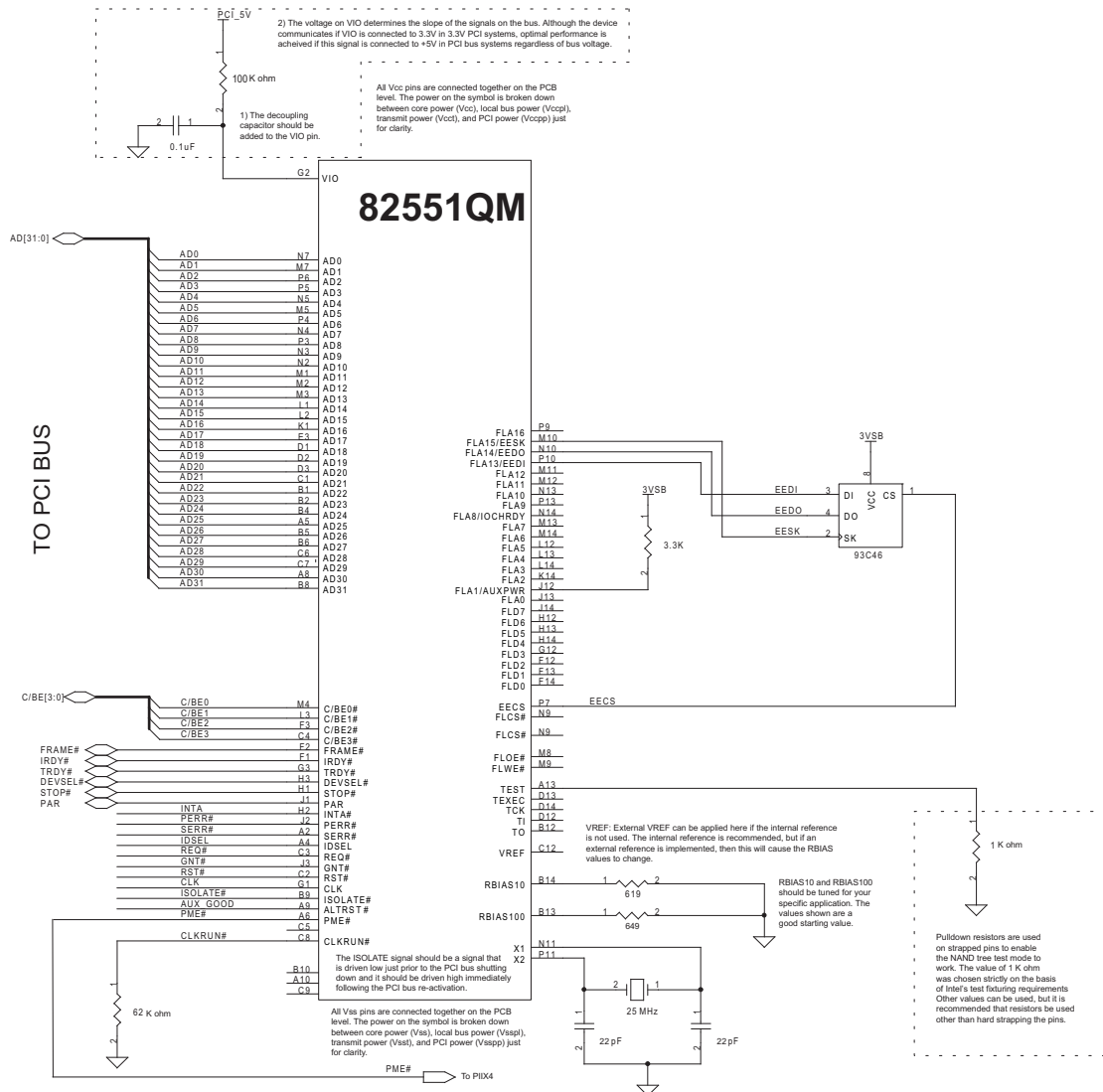

Figure 35. Reference Schematic Layout (Sheet 2 of 2)