

DESCRIPTION

The MC33164-3 and MC34164-3 are undervoltage sensing circuits designed specifically for use as reset controllers in microprocessor-based systems. They offer the designer an economical, space efficient solution for low supply voltage detection when used in combination with a single pull-up resistor. Adding one capacitor offers the functionality of a programmable delay time after power

returns. The MC33164-3 and MC34164-3 consist of a temperature stable reference comparator with hysteresis, high-current clamping diode and an open collector output stage capable of sinking more than 6mA over the full temperature range. The MC33164-3 and MC34164-3's RESET output is specified to be fully functional at $V_{IN} \geq 1V$. See Product Highlight below.

KEY FEATURES

- Monitors +3.3V Supplies ($V_T = 2.7V$ Typ)
- Outputs Fully Defined At $V_{IN} \geq 1V$ (See Product Highlight)
- Ultra-Low Supply Current (13 μ A Max.)
- Temperature Compensated I_{CC} For Extremely Stable Current Consumption
- μ P Reset Delay Programmable With 1 External Resistor And Capacitor
- Comparator Hysteresis Prevents Output Oscillation (60mV Typ.)
- Electrically Compatible With Motorola MC34164-3
- Pin-to-Pin Compatible With Motorola MC34064 / MC34164

APPLICATIONS

- All Microprocessor Or Microcontroller Designs Using 3V/3.3V Supplies
- Simple 3V/3.3V Undervoltage Detection

IMPORTANT: For the most current data, consult MICROSEMI's website: <http://www.microsemi.com>

PRODUCT HIGHLIGHT

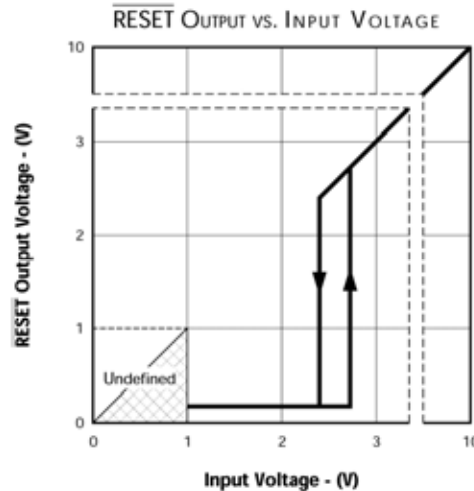

PACKAGE ORDER INFO

T_A (°C)	DM Plastic SOIC 8-Pin	LP Plastic TO-92 3-Pin
	RoHS Compliant / Pb-free Transition DC: 0440	RoHS Compliant / Pb-free Transition DC: 0509
0 to 70	MC34164-3DM	MC34164-3LP
-40 to 85	MC33164-3DM	MC33164-3LP

Note: Available in Tape & Reel. Append the letters "TR" to the part number. (i.e. MC34164-3DM-TR)

MC33164-3/MC34164-3

3V UNDERVOLTAGE SENSING CIRCUIT

PRODUCTION DATA SHEET

ABSOLUTE MAXIMUM RATINGS (Note 1)

Input Supply Voltage (V_{IN})	-1V to 12V
\overline{RESET} Output Voltage (V_{OUT})	12V
Output Sink Current (I_{OL})	Internally Limited (mA)
Clamp Diode Forward Current (I_F), Pin 1 to pin 2	100mA
Operating Junction Temperature	
Plastic (DM, LP - Packages)	150°C
Storage Temperature Range	-65°C to 150°C
Lead Temperature (Soldering, 10 seconds)	300°C
Peak Package Solder Reflow Temp. (40 second max. exposure)	260°C (+0, -5)

Note 1. Values beyond which damage may occur. All voltages are specified with respect to ground, and all currents are positive into the specified terminal.

THERMAL DATA

DM PACKAGE:

THERMAL RESISTANCE-JUNCTION TO AMBIENT, θ_{JA}	165°C/W
---	---------

LP PACKAGE:

THERMAL RESISTANCE-JUNCTION TO AMBIENT, θ_{JA}	156°C/W
---	---------

Junction Temperature Calculation: $T_J = T_A + (P_D \times \theta_{JA})$.
 The θ_{JA} numbers are guidelines for the thermal performance of the device/pc-board system.
 All of the above assume no ambient airflow

PACKAGE PIN OUTS

\overline{RESET}	1	8	N.C.
V_{IN}	2	7	N.C.
N.C.	3	6	N.C.
GROUND	4	5	N.C.

DM PACKAGE (Top View)

RoHS / Pb-free 100% Matte Tin Lead Finish

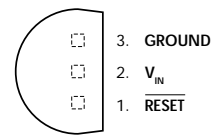

LP PACKAGE (Top View)

BLOCK DIAGRAM

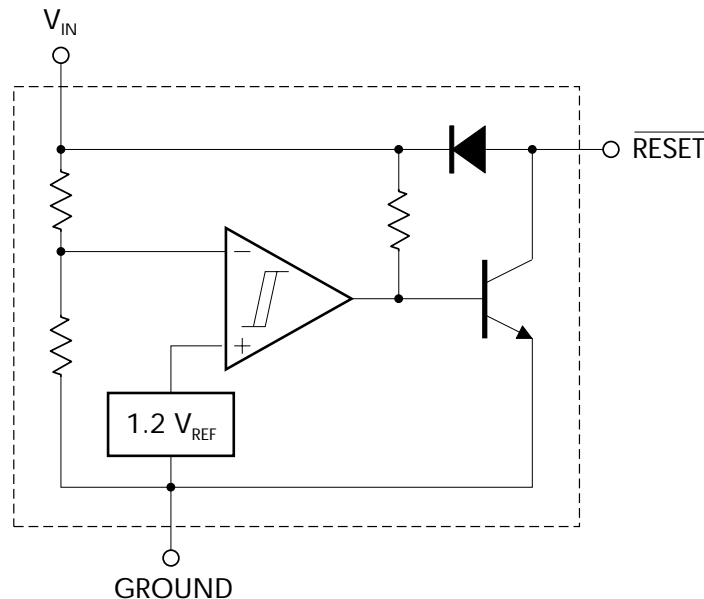

3V UNDERVOLTAGE SENSING CIRCUIT

PRODUCTION DATA SHEET

RECOMMENDED OPERATING CONDITIONS (Note 2)

Parameter	Symbol	Recommended Operating Conditions			Units
		Min.	Typ.	Max.	
Input Supply Voltage	V_{IN}	1		10	V
RESET Output Voltage	V_{OUT}	-0.3		10	V
Clamp Diode Forward Current (Note 3)	I_F			100	mA
Operating Ambient Temperature Range:					
MC34164-3	T_A	0		70	°C
MC33164-3	T_A	-40		85	°C

Note 2. Range over which the device is guaranteed functional.

Note 3. Maximum junction temperature ratings must be observed.

ELECTRICAL CHARACTERISTICS

(Unless otherwise specified, these specifications apply over the operating ambient temperatures of $0^\circ\text{C} \leq T_A \leq 70^\circ\text{C}$ for the MC34164-3 and $-40^\circ\text{C} \leq T_A \leq 85^\circ\text{C}$ for the MC33164-3. Low duty cycle pulse testing techniques are used which maintains junction and case temperatures equal to the ambient temperature.)

Parameter	Symbol	Test Conditions	MC33164-3 / 34164-3			Units
			Min.	Typ.	Max.	
Comparator Section						
Threshold Voltage						
High State Output	V_{T+}	V_{IN} Increasing — 2.4V to 3.5V	2.55	2.71	2.8	V
Low State Output	V_{T-}	V_{IN} Decreasing — 3.5V to 2.4V	2.55	2.65	2.8	V
Hysteresis	V_H	($I_{OL} = 100\mu\text{A}$)	0.03	0.06		V
RESET Output Section						
Output Low Level Saturation Voltage	V_{OL}	$V_{IN} = 2.4\text{V}, I_{OL} = 8.0\text{mA}$		0.15	1.0	V
		$V_{IN} = 2.4\text{V}, I_{OL} = 1.0\text{mA}$		0.04	0.4	V
		$V_{IN} = 1.0\text{V}, I_{OL} = 0.25\text{mA}$		0.02	0.3	V
Output Low Level Current	I_{OL}	$V_{IN}, \text{RESET} = 2.4\text{V}$	6.0	24	40	mA
Output Off-State Leakage	I_{OH}	$V_{IN}, \text{RESET} = 3.0\text{V}$.02	0.5	μA
		$V_{IN}, \text{RESET} = 10\text{V}$.02	1.0	μA
Clamp Diode Forward Voltage	V_F	Pin 1 to pin 2, $I_F = 5\text{mA}$	0.6	0.75	1.0	V
Total Device						
Supply Current	I_{CC}	$V_{IN} = 3.0\text{V}$		9	13	μA
		$V_{IN} = 6.0\text{V}$		21	30	μA

GRAPH / CURVE INDEX

Characteristic Curves

FIGURE

1. INPUT VOLTAGE vs. $\overline{\text{RESET}}$ OUTPUT VOLTAGE
2. POWER-UP $\overline{\text{RESET}}$ VOLTAGE
3. POWER-DOWN $\overline{\text{RESET}}$ VOLTAGE
4. $\overline{\text{RESET}}$ OUTPUT VOLTAGE vs. INPUT VOLTAGE HYSTERESIS
5. THRESHOLD VOLTAGE vs. TEMPERATURE
6. THRESHOLD HYSTERESIS vs. TEMPERATURE
7. SUPPLY CURRENT vs. INPUT VOLTAGE
8. SUPPLY CURRENT vs. TEMPERATURE
9. LOW LEVEL OUTPUT CURRENT vs TEMPERATURE
10. LOW LEVEL OUTPUT SATURATION VOLTAGE vs. TEMPERATURE
11. LOW LEVEL OUTPUT SATURATION VOLTAGE vs. TEMPERATURE
12. CLAMP DIODE FORWARD VOLTAGE vs. FORWARD CURRENT
13. PROPAGATION DELAY — HIGH to LOW
14. PROPAGATION DELAY — LOW to HIGH
15. MINIMUM OPERATING VOLTAGE OVER TEMPERATURE

FIGURE INDEX

Application Circuits

FIGURE

16. LOW VOLTAGE MICROPROCESSOR RESET
17. SWITCHING THE LOAD OFF WHEN BATTERY REACHES BELOW 2.7V
18. VOLTAGE MONITOR
19. SOLAR POWERED BATTERY CHARGER

3V UNDERVOLTAGE SENSING CIRCUIT

PRODUCTION DATA SHEET

CHARACTERISTIC CURVES

FIGURE 1. — INPUT VOLTAGE and $\overline{\text{RESET}}$ OUTPUT VOLTAGE vs. TIME

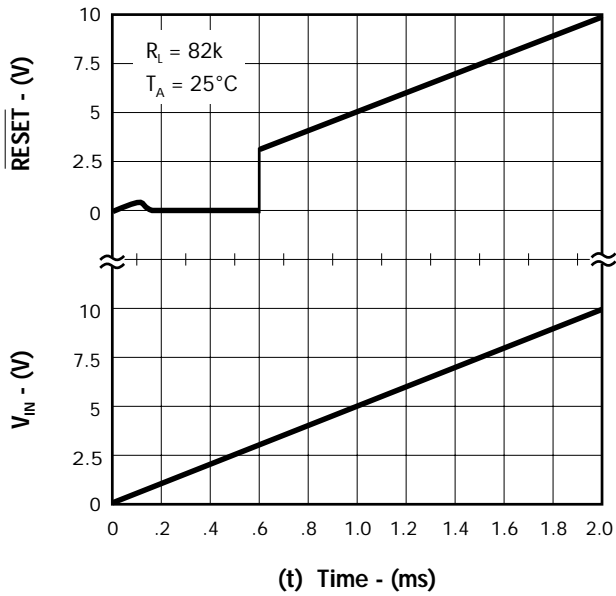

FIGURE 2. — POWER-UP $\overline{\text{RESET}}$ VOLTAGE

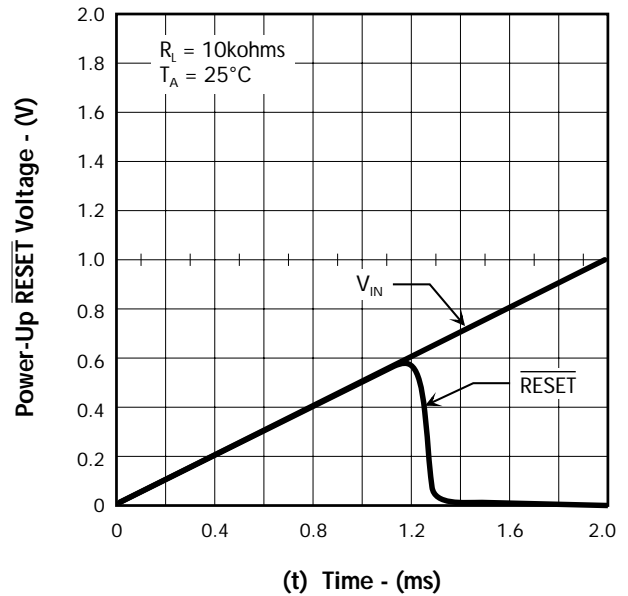

FIGURE 3. — POWER-DOWN $\overline{\text{RESET}}$ VOLTAGE

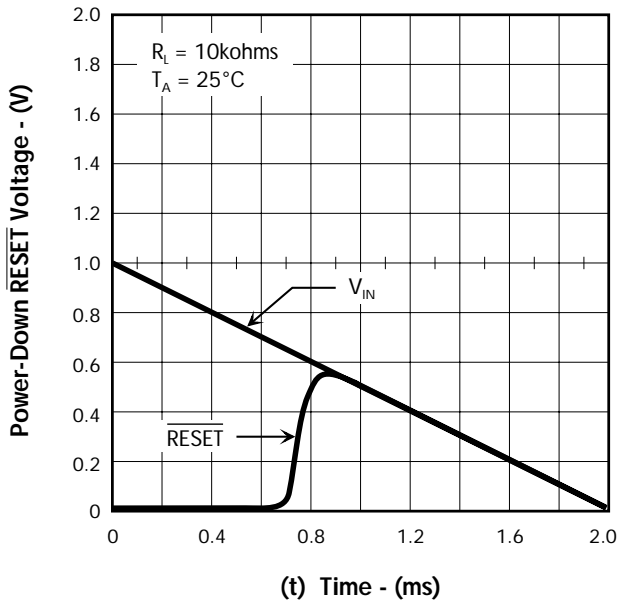
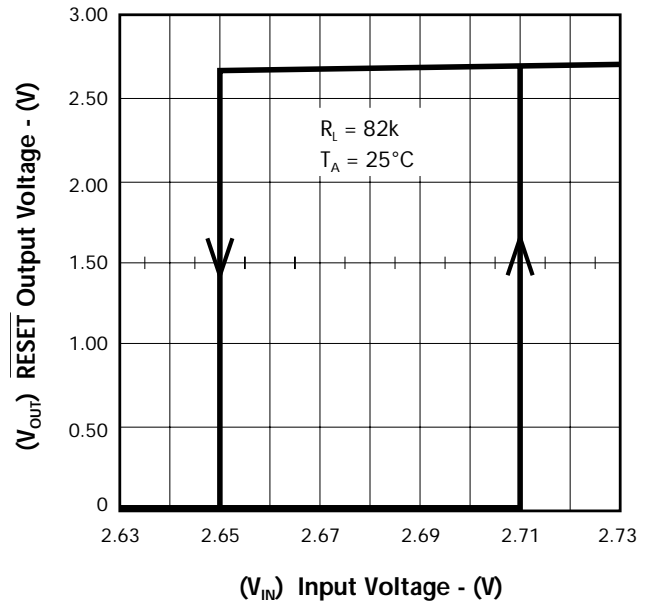

FIGURE 4. — $\overline{\text{RESET}}$ OUTPUT VOLTAGE vs. INPUT VOLTAGE



CHARACTERISTIC CURVES

FIGURE 5. — THRESHOLD VOLTAGE vs. TEMPERATURE

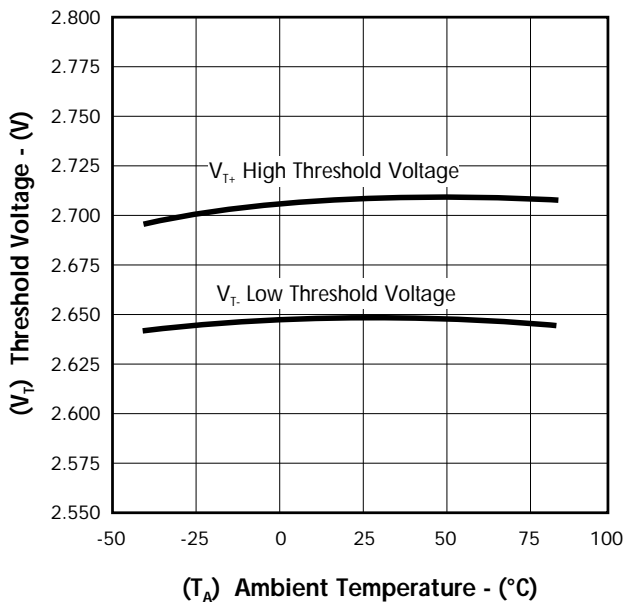

FIGURE 6. — THRESHOLD HYSTERESIS vs. TEMPERATURE

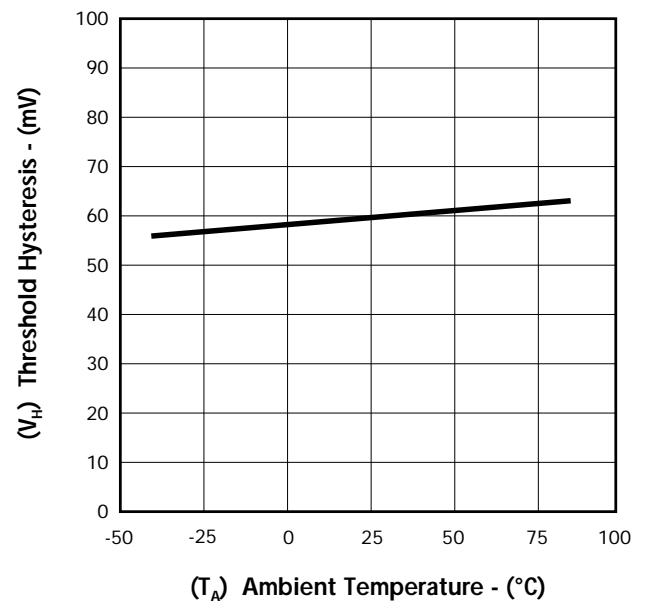

FIGURE 7. — SUPPLY CURRENT vs. INPUT VOLTAGE

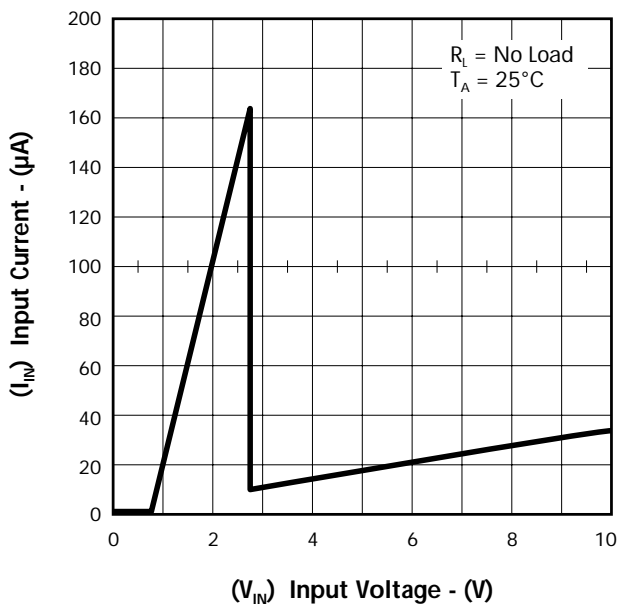
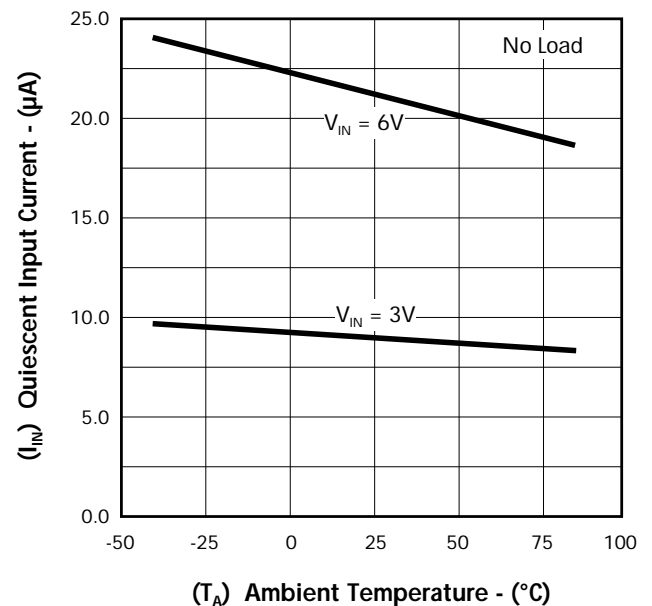

FIGURE 8. — SUPPLY CURRENT vs. TEMPERATURE



3V UNDERVOLTAGE SENSING CIRCUIT

PRODUCTION DATA SHEET

CHARACTERISTIC CURVES

FIGURE 9. — LOW LEVEL OUTPUT CURRENT vs. TEMPERATURE

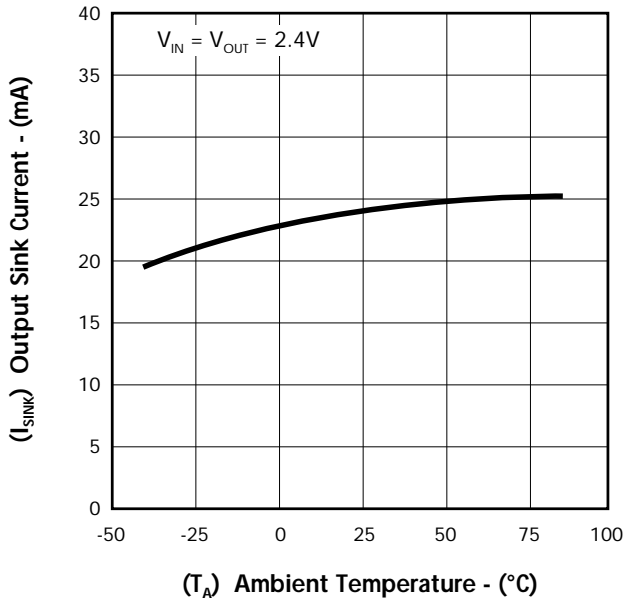

FIGURE 10. — LOW LEVEL OUTPUT SATURATION VOLTAGE vs. TEMPERATURE

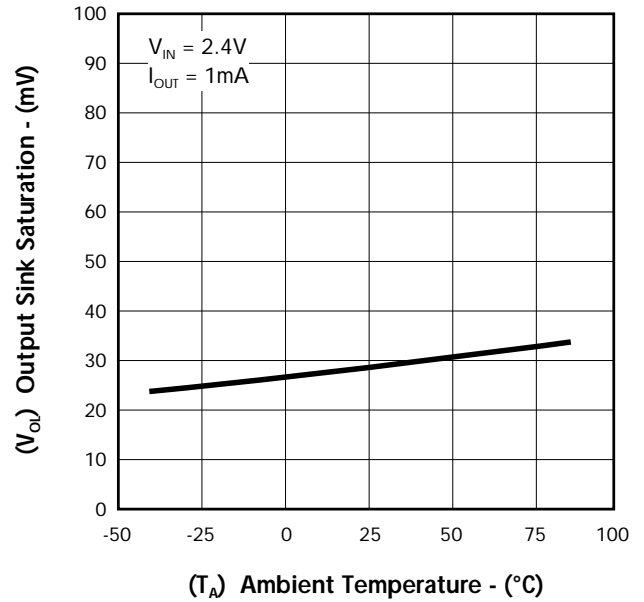

FIGURE 11. — LOW LEVEL OUTPUT SATURATION VOLTAGE vs. TEMPERATURE

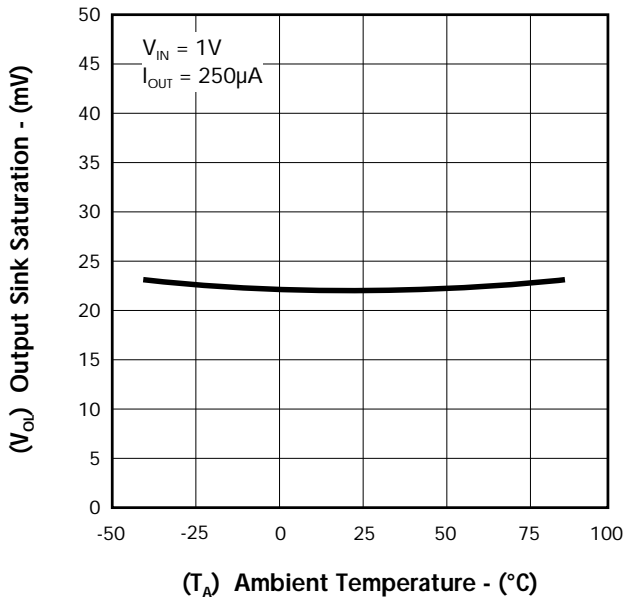
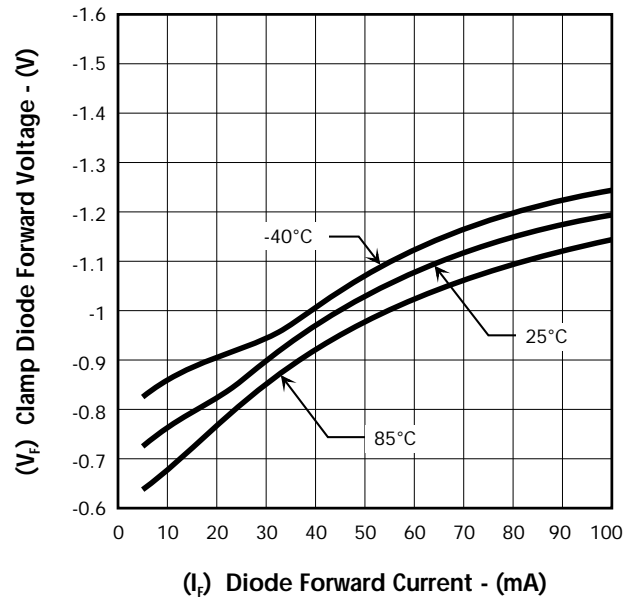

FIGURE 12. — CLAMP DIODE FORWARD VOLTAGE vs. FORWARD CURRENT



MC33164-3/MC34164-3

3V UNDERVOLTAGE SENSING CIRCUIT

PRODUCTION DATA SHEET

CHARACTERISTIC CURVES

FIGURE 13. — PROPAGATION DELAY — HIGH to LOW

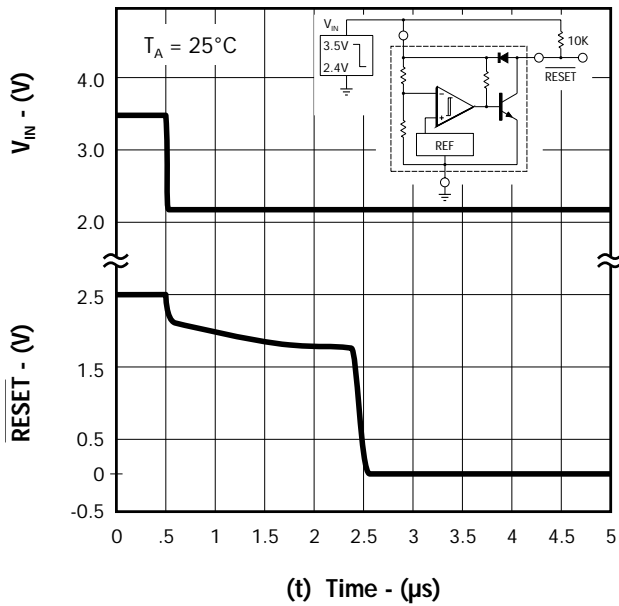

FIGURE 14. — PROPAGATION DELAY — LOW to HIGH

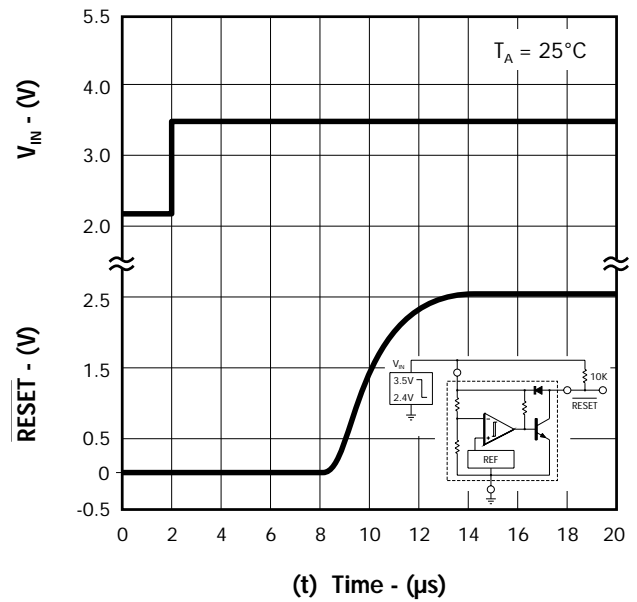
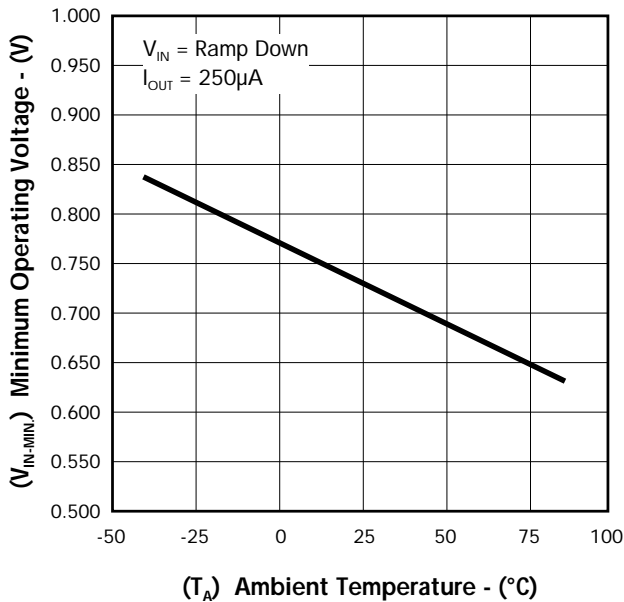

FIGURE 15. — MINIMUM OPERATING VOLTAGE OVER TEMPERATURE



3V UNDERVOLTAGE SENSING CIRCUIT

PRODUCTION DATA SHEET

TYPICAL APPLICATION CIRCUITS

FIGURE 16. — LOW VOLTAGE MICROPROCESSOR RESET

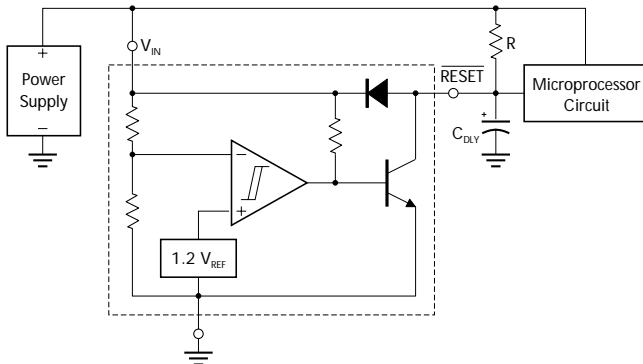

A time delayed reset can be accomplished with the addition of C_{DLY} . For systems with extremely fast power supply rise times ($< 500\text{ns}$) it is recommended that the RC_{DLY} time constant be greater than $5.0\mu\text{s}$. $V_{TH(MPU)}$ is the microprocessor reset input threshold.

$$t_{DLY} = R C_{DLY} \ln \left[\frac{1}{1 - \frac{V_{TH(MPU)}}{V_{IN}}} \right]$$

FIGURE 17. — SWITCHING THE LOAD OFF WHEN BATTERY REACHES BELOW 2.7V

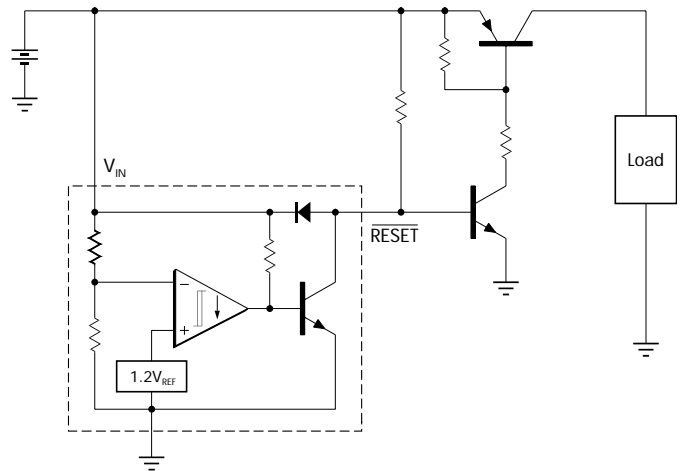
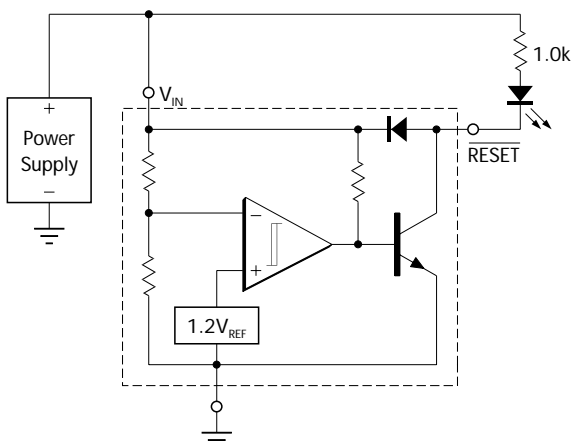
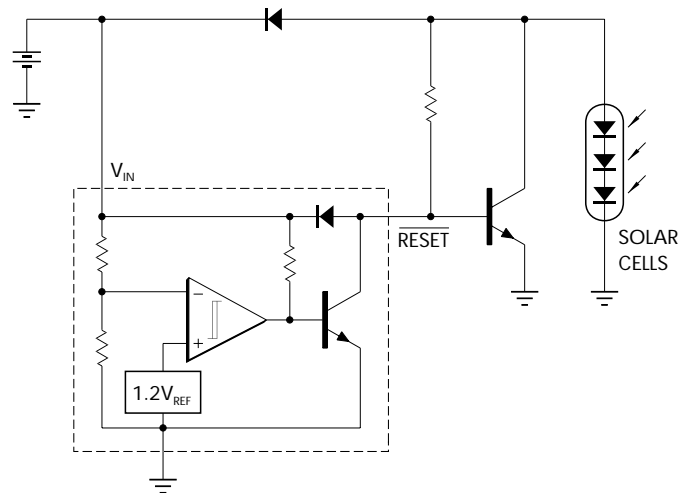

FIGURE 18. — VOLTAGE MONITOR



LED turns on when $V_{IN} < 2.7\text{V}$ indicating Power Supply is low.

FIGURE 20. — SOLAR POWERED BATTERY CHARGER



PRODUCTION DATA - Information contained in this document is proprietary to Linfinity, and is current as of publication date. This document may not be modified in any way without the express written consent of Linfinity. Product processing does not necessarily include testing of all parameters. Linfinity reserves the right to change the configuration and performance of the product and to discontinue product at any time.