



FEATURES

- Operating Input Voltage From 4.5V to 36V
- 2.5V, 3.3V, 5V , 12V and Adjustable Output Version
- Adjustable Version Output Voltage Range , 1.25V to 30V \pm 4% max Over Line and Load Regulation
- Available in TO220-5 and TO263-5 Package
- Requires Only 4 External Components.
- 150KHz/300KHz Fixed Constant Frequency
- Low Power Standby Mode, I_Q Typically 80 μ A
- TTL Shutdown Capability.
- Output Overvoltage Protection
- Current Limit and Thermal Shutdown Protection.
- 2A Guaranteed Output Current

APPLICATIONS

- Simple High Efficiency Step-down regulator
- On-Card Switching regulators
- Fixed Voltage power supply for LCD Monitor

DESCRIPTION

The AIC1595 series are step-down monolithic PWM regulators delivering 2A at fixed voltages of 2.5V , 3.3V, 5.0V , 12V and using a external divider to adjust output voltage from 1.25V to 30V with excellent line and load regulation.

Switching frequency up to 150KHz/300KHz are achievable thus allowing smaller sized filter components. Internal current limit and thermal shutdown circuits provide protection from overloads. It also provides output overvoltage and short protection under fault conditions.

The internal precious reference combined with voltage feedback loop provides optimum output voltage accuracy and fast load transient response.

Packages available are in standard TO220-5 for standard assembly and TO263-5 for SMD.

TYPICAL APPLICATION CIRCUIT

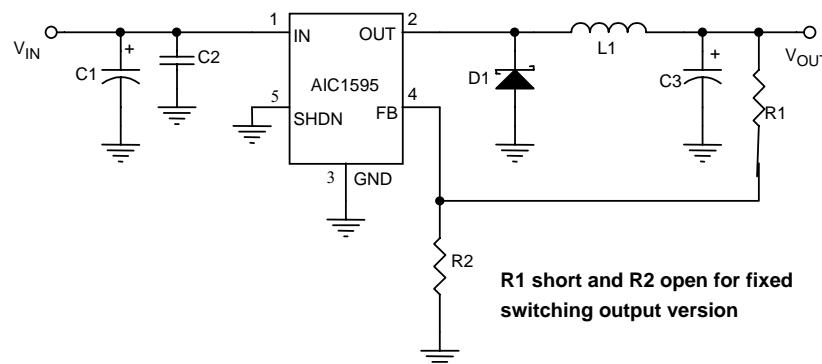

2A Precision PWM DC/DC Regulator



ORDERING INFORMATION

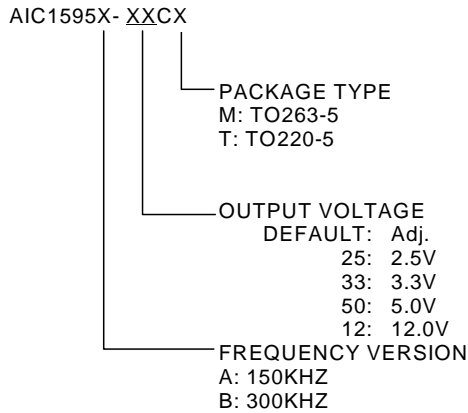

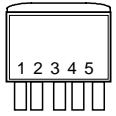
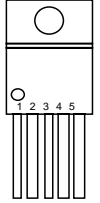
ORDER NUMBER	PIN CONFIGURATION
AIC1595A(B)CM AIC1595A(B)-25CM AIC1595A(B)-33CM AIC1595A(B)-50CM AIC1595A(B)-12CM (TO263-5)	FRONT VIEW 1: IN 2: OUT 3: GND 4: FB 5: SHDN 
AIC1595A(B)CT AIC1595A(B)-25CT AIC1595A(B)-33CT AIC1595A(B)-50CT AIC1595A(B)-12CT (TO220-5)	FRONT VIEW 1: IN 2: OUT 3: GND 4: FB 5: SHDN 

ABSOLUTE MAXIMUM RATINGS

Supply Voltage	36V
FB, SHDN Pin Input Voltage	25V
Operating Temperature Range	0°C ~ 70°C
Storage Temperature Range	-65°C ~ 150°C

TEST CIRCUIT

Refer to Typical Application Circuit.

**ELECTRICAL CHARACTERISTICS** ($T_J=25^{\circ}\text{C}$, $V_{IN}=18\text{V}$)

PARAMETER	TEST CONDITIONS	MIN.	TYP.	MAX.	UNIT
Input Voltage		4.5		36	V
Fixed Output Voltage	AIC1595-25 ($V_{IN} > 4.5\text{V}$)		2.5		V
	AIC1595-33 ($V_{IN} > 4.5\text{V}$)		3.3		V
	AIC1595-50 ($V_{IN} > 7.0\text{V}$)		5.0		V
	AIC1595-12 ($V_{IN} > 15\text{V}$)		12.0		V
Feedback Voltage	AIC1595 Adjustable		1.25		V
Output Voltage Regulation				4	%
Quiescent Current	Internal switch off		1	5	mA
Shutdown Quiescent Current	SHDN = 5V (OFF)		80		μA
Logic Input High	(Regulator OFF)	2			V
Logic Input Low	(Regulator ON)			0.8	V
Oscillator Frequency	AIC1595A series		150		
Oscillator Frequency	AIC1595B series		300		KHz
Output Current Limit		2.0			A
Over Voltage Protection			120		%
Maximum Duty Cycle		100			%
Efficiency	$V_o=5\text{V}$, $I_o=2\text{A}$		90		%



PIN DESCRIPTIONS

- PIN 1: IN** Supply voltage input for the IC switching regulator. A suitable input bypass capacitor must be present at this pin to minimize voltage transients and to supply the switching currents needed by the regulator.
- PIN 2: OUT** Internal switch. The voltage at this pin switches between $(V_{IN}-V_{SAT})$ and approximately $-0.5V$, with a duty cycle of approximately V_{OUT}/V_{IN} .
- PIN 3: GND** Ground requires a short, low noise connection to ensure good load regulation.
- PIN 4: FB** Feedback input for fixed-output or adjustable-output version. Connect directly to output for fixed operation version or to a resistor divider for adjustable operation versions.
- PIN 5: SHDN** Allows the switching regulator circuit to be shutdown using logic level signals thus dropping the total input supply current to approximately $80\mu A$. Drive it high to disable the reference, control circuitry and internal switches. Drive low or connect to GND for normal operation.

BLOCK DIAGRAM

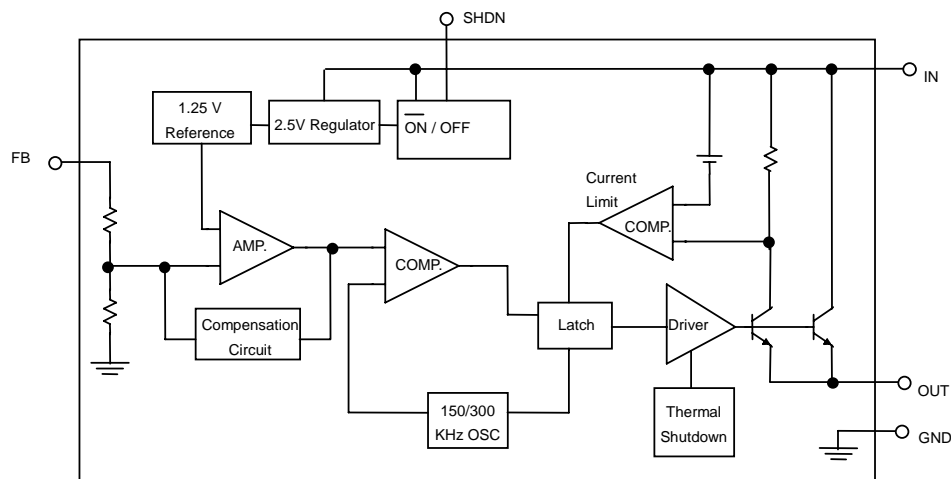



PHYSICAL DIMENSIONS

● TO-263-5L (unit: mm)

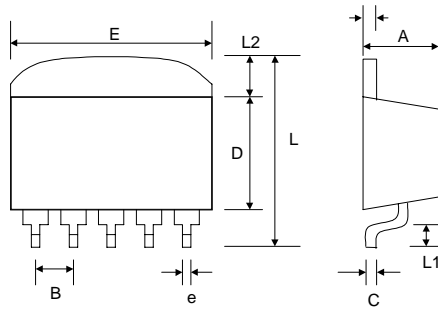

SYMBOL	MIN	MAX
A	4.07	4.83
B	1.45	1.96
C	0.36	0.64
C2	1.14	1.40
D	8.63	9.66
E	9.78	10.54
E	0.71	1.02
L	15.11	15.59
L1	2.28	2.80
L2	-	1.40

● TO-220-5 (unit: mm)

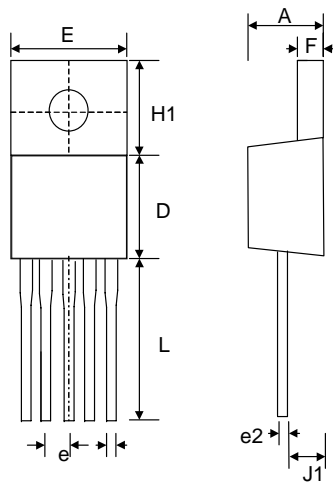

SYMBOL	MIN	MAX
A	4.06	4.83
D	8.35	8.89
E	9.78	10.54
e	1.57	1.85
e1	0.76	1.02
e2	0.33	0.64
F	1.14	1.40
H1	5.46	6.86
J1	2.29	3.18
L	13.21	14.73