Step-Down Switching Regulator Controller**■ FEATURES**

- Operation Voltage up to 15V.
- Simple Voltage-Mode PWM Control.
- Fast Transient Response.
- 2V and 1.3V \pm 2% Feedback Voltage Reference Option.
- Adjustable Current Limit without External Sense Resistors.
- 200KHz Free-Running Oscillator.
- Short-Circuit Protection with Low Short Circuit Output Current.

■ APPLICATIONS

- Power Supply for Motherboard V_{GTL} (1.5V Output)
- Power Supply for Motherboard V_{IO} .
- High-Power 5V to 3.xV DC/DC Regulators.
- Low-Voltage Distributed Power Supplies.

■ DESCRIPTION

The AIC1579 is a high-power, high-efficiency voltage-mode switching regulator controller for motherboard V_{IO} power supply applications. Designed to drive an N-channel MOSFET in a standard buck topology, the AIC1579 features a high voltage CMOS output driver, short-circuit protection, and 8-pin package.

An external 4-bit Digital-to-Analog Converter (DAC) can be used along with the AIC1579 to adjust the output voltage from 2.0V to 3.5V in 0.1V increments. Table 1 on the following page specifies the corresponding output voltage for 16 combinations of DAC inputs as in the typical application circuit.

The 200KHz switching frequency allows for using small external components while maintaining high conversion efficiency. The 11MHz bandwidth and 6V/ μ S slew rate of the error amplifier ensures high converter bandwidth and fast transient response.

The AIC1579 provides adjustable overcurrent and short-circuit protections by sensing the output current across the on resistance of the external N-channel MOSFET rather than an external low value sense resistor.

The AIC1579L provides lower reference voltage (1.30V) than the default (2.00V, AIC1579) for lower V_{OUT} requirement.

ORDERING INFORMATION

AIC1579 XXX

PACKAGE TYPE
 N: PLASTIC DIP
 S: SMALL OUTLINE

TEMPERATURE RANGE
 C=0°C~+70°C

REFERENCE VOLTAGE
 DEFAULT: 2.00V
 L: 1.30V

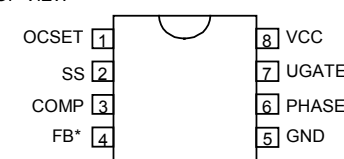
ORDER NUMBER	PIN CONFIGURATION
AIC1579CN AIC1579LCN (PLASTIC DIP)	TOP VIEW 
AIC1579CS AIC1579LCS (PLASTIC SO)	
*AIC1579: 2.00V AIC1579L: 1.30V	

TYPICAL APPLICATION CIRCUIT

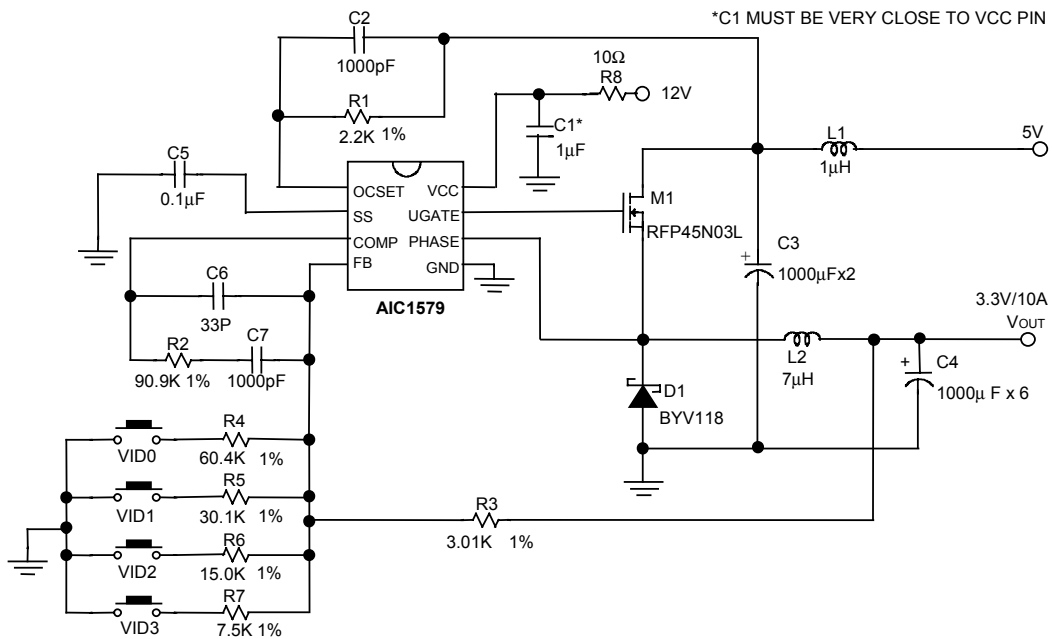

Switching Regulator for Pentium® V_{CORE} Supply

Table 1. Output Voltage Program

VID3	VID2	VID1	VID0	VOUT
1	1	1	1	2.00V
1	1	1	0	2.10V
1	1	0	1	2.20V
1	1	0	0	2.30V
1	0	1	1	2.40V
1	0	1	0	2.50V
1	0	0	1	2.60V
1	0	0	0	2.70V
0	1	1	1	2.80V
0	1	1	0	2.90V
0	1	0	1	3.00V
0	1	0	0	3.10V
0	0	1	1	3.20V
0	0	1	0	3.30V
0	0	0	1	3.40V
0	0	0	0	3.50V

■ ABSOLUTE MAXIMUM RATINGS

Supply Voltage, V_{CC} 15V
 Input, Output, or I/O Voltage GND-0.3V to $V_{CC}+0.3V$
 ESD Classification Class 2

Recommended Operating Conditions

Supply Voltage, V_{CC} $12V \pm 10\%$
 Ambient Temperature Range $0^{\circ}C \sim 70^{\circ}C$
 Junction Temperature Range $0^{\circ}C \sim 100^{\circ}C$

Thermal Information

Thermal Resistance, θ_{JA} (Typical, Note 1)
 SOIC Package $100^{\circ}C/W$
 SOIC Package (with 3 in² of Copper) $90^{\circ}C/W$
 Maximum Junction Temperature (Plastic Package) $150^{\circ}C$
 Maximum Storage Temperature Range $-65^{\circ}C \sim 150^{\circ}C$
 Maximum Lead Temperature (Soldering 10 Sec) $300^{\circ}C$
 Note 1: θ_{JA} is measured with the component mounted on an evaluation PC board in free air.

■ TEST CIRCUIT

Refer to TYPICAL APPLICATION CIRCUIT.

ELECTRICAL CHARACTERISTICS (VCC= 12V, Ta=25°C, unless otherwise specified.)

PARAMETER	TEST CONDITIONS	SYMBOL	MIN.	TYP.	MAX.	UNIT
VCC Supply Current						
Nominal Supply	UGATE Open	I_{VCC}		2.3		mA
Power-On Reset						
V _{CC} Threshold	V _{OCSET} =4.5V				10.4	V
Oscillator						
Frequency			160	200	240	KHz
Max. Duty Cycle					100	%
Internal Reference Voltage						
Reference Voltage	AIC1579 AIC1579L		1.96 1.27	2.00 1.30	2.04 1.33	V
Error Amplifier						
DC Gain				76		dB
Gain-Bandwidth Product		GBW		11		MHz
Slew Rate		SR		6		V/μS
Gate Driver						
Upper Gate Source		R _{UGATE}		8	12	Ω
Upper Gate Sink		R _{UGATE}		5.5	10	Ω
Protection						
OCSET Current Source	V _{OCSET} =4.5VDC	I _{OCSET}	170	200	230	μA
SS Current		I _{SS}		10		μA

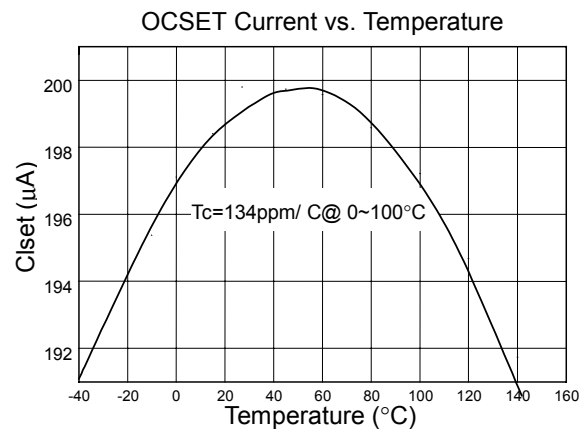
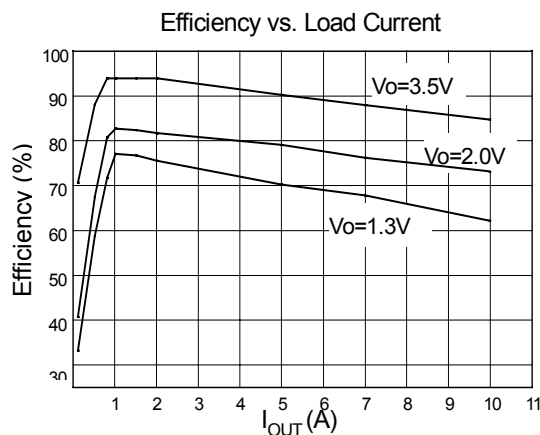
TYPICAL PERFORMANCE CHARACTERISTICS

■ **TYPICAL PERFORMANCE CHARACTERISTICS(Continued)**

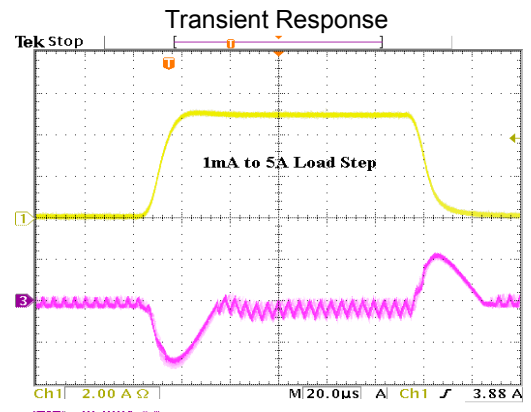
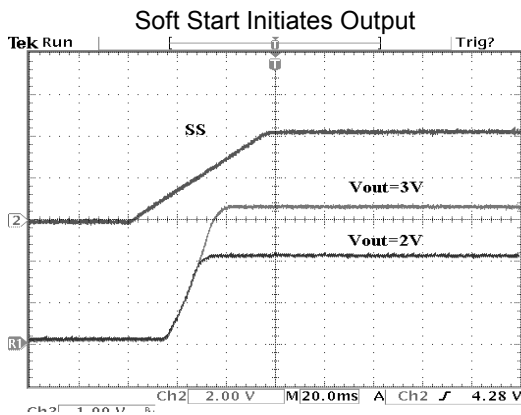
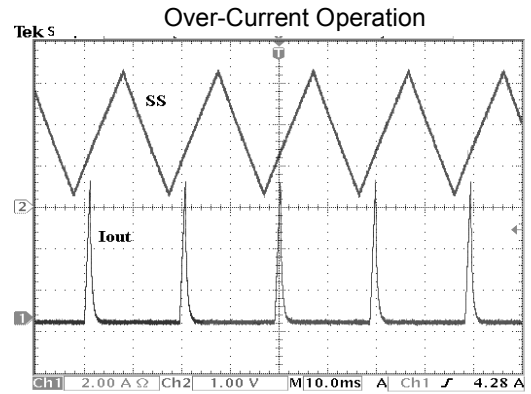
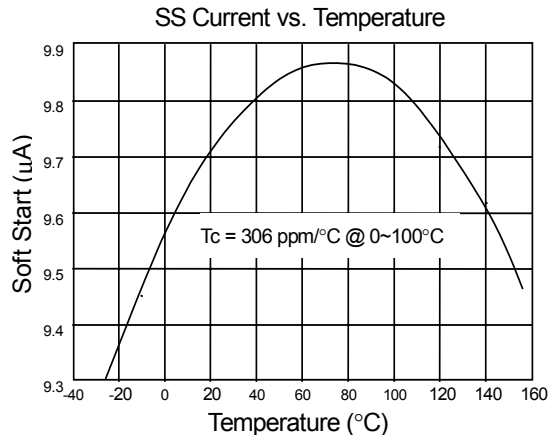

■ BLOCK DIAGRAM

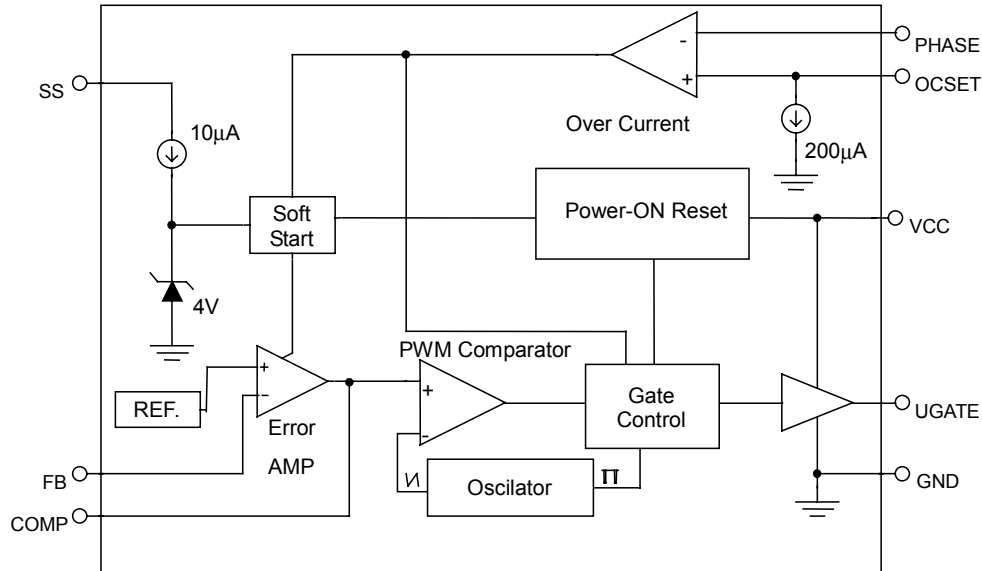

■ PIN DESCRIPTIONS

PIN 1: OCSET- Current limit sense pin. Connect a resistor R_{OCSET} from this pin to the drain of the external MOSFET. R_{OCSET} , an internal $200\mu A$ current source (I_{OCSET}), and the external MOSFET on-resistance ($R_{DS(ON)}$) jointly set the overcurrent trip point according to the following equation:

$$I_{PEAK} = \frac{I_{OCSET} \times R_{OCSET}}{R_{DS(ON)}}$$

If FB pin voltage is sensed to be below 50% of the internal voltage reference VDAC, the overcurrent comparator cycles the soft-start function.

PIN 2: SS - Soft start pin. Connect a capacitor from this pin to ground. An internal $10\mu A$ current source provides soft start function for the converter.

PIN 3: COMP - External compensation pin. This pin is connected to error amplifier output and PWM

comparator. A RC network is connected to FB pin to compensate the voltage-control feedback loop of the converter.

PIN 4: FB - The error amplifier inverting input pin. The FB pin and COMP pin are used to compensate the voltage-control feedback loop.

PIN 5: GND- Ground pin.

PIN 6: PHASE- Overcurrent detection pin. Connect the PHASE pin to source of the external N-MOSFET. This pin detects the voltage drop across the MOSFET $R_{DS(ON)}$ for overcurrent protection.

PIN 7: UGATE- External MOSFET gate drive pin. Connect this pin to gate of the external MOSFET.

PIN 8: VCC -The chip power supply pin. Recommended supply voltage is 12V.

APPLICATION CIRCUIT

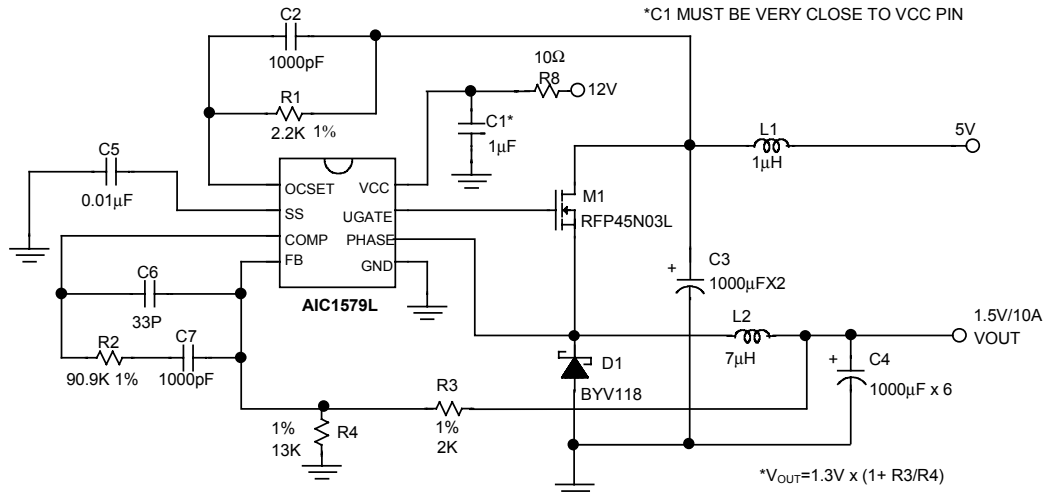

PHYSICAL DIMENSIONS

- 8 LEAD PLASTIC SO (unit: mm)

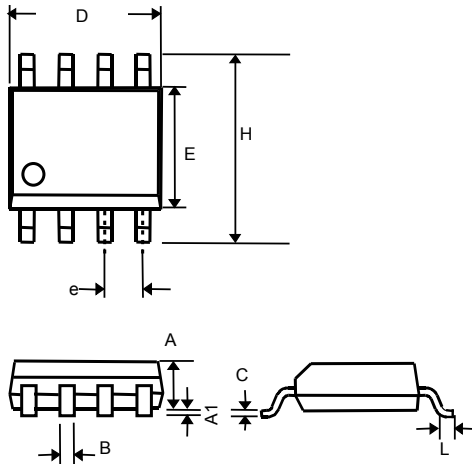

SYMBOL	MIN	MAX
A	1.35	1.75
A1	0.10	0.25
B	0.33	0.51
C	0.19	0.25
D	4.80	5.00
E	3.80	4.00
e	1.27(TYP)	
H	5.80	6.20
L	0.40	1.27

- **8 LEAD PLASTIC DIP (unit: mm)**

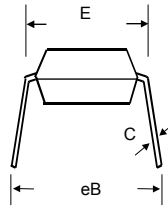
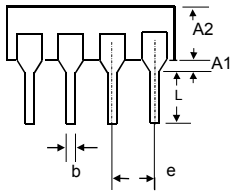
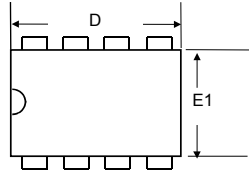

SYMBOL	MIN	MAX
A1	0.381	—
A2	2.92	4.96
b	0.35	0.56
C	0.20	0.36
D	9.01	10.16
E	7.62	8.26
E1	6.09	7.12
e	2.54 (TYP)	
eB	—	10.92
L	2.92	3.81