

## ■ FEATURES

- 3A Source and Sink Current Ability
- Support DDR1 (1.25V<sub>TT</sub>) and DDR2 (0.9V<sub>TT</sub>) Requirements
- Low Output Voltage Offset, ±20mV
- High Accuracy Output Voltage at Full-Load
- Adjustable V<sub>OUT</sub> by External Resistor
- Low External Component Count
- Current Limit protection
- Thermal Protection
- SOP-8, TO-252 and TO-263 Packages

## ■ APPLICATIONS

- Mother Board
- Graphic Cards
- DDR Termination Voltage Supply

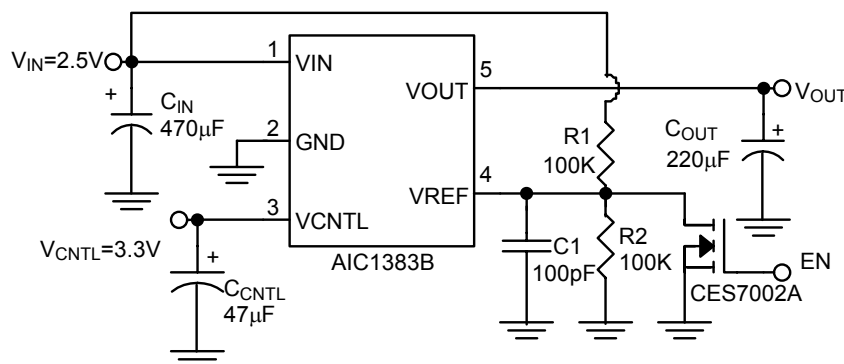
## ■ DESCRIPTION

AIC1383B linear regulator is designed to achieve 3A source and sink current while regulating an output voltage to within 45mV.

AIC1383B converts voltage supplies range from 1.6V to 6V into an output voltage that adjusts by two external voltage divider resistors. It provides an excellent voltage source for active termination schemes of high-speed transmission lines as those seen in high-speed memory buses, and it meets the JEDEC SSTL-2 and SSTL-3 specifications for termination of DDR-SRAM.

Built-in current limiting in source and sink mode, with thermal shutdown provide maximal protection to the AIC1383B against fault conditions.

## ■ TYPICAL APPLICATION CIRCUIT



## ORDERING INFORMATION

AIC1383BXXX XX

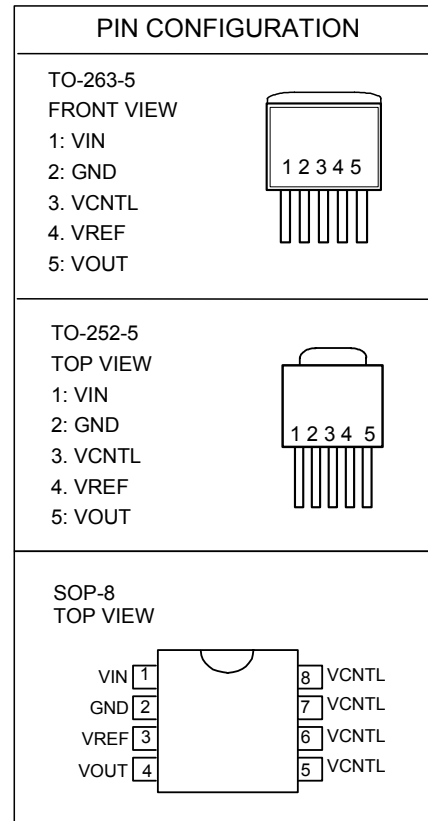
PACKING TYPE  
TR: TAPE & REEL

PACKAGE TYPE  
M5: TO-263-5  
E5: TO-252-5  
S: SOP-8

C: COMMERCIAL  
P: LEAD FREE COMMERCIAL

Example: AIC1383BCE5TR  
→ 3A Version, in TO-252-5 Package,  
Tape & Reel Packing Type

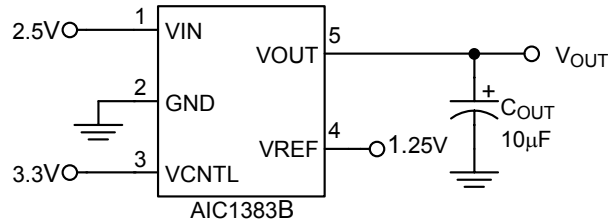
AIC1383BPE5TR  
→ 3A Version, in Lead Free TO-252-5  
Package, Tape & Reel Packing



## ABSOLUTE MAXIMUM RATINGS

Supply Voltage.....	-0.4V to 7V
Operating Temperature Range.....	-40°C~85°C
Junction Temperature .....	125°C
Storage Temperature Range.....	-65°C ~150°C
Lead Temperature (Solder, 10sec).....	260°C
Thermal Resistance $\theta_{JC}$	
TO-263.....	3°C /W
TO-252.....	12.5°C /W
SO-8.....	40°C /W
Thermal Resistance $\theta_{JA}$	
TO-263.....	60°C /W
TO-252.....	100°C /W
SO-8.....	160°C /W

**Absolute Maximum Ratings are those values beyond which the life of a device may be impaired.**

**TEST CIRCUIT**

**ELECTRICAL CHARACTERISTICS**

( $V_{CNTL}=3.3V$ ,  $V_{IN}=2.5V$ ,  $V_{REF}=0.5V_{IN}$ ,  $C_{OUT}=10\mu F$ ,  $T_A=25^\circ C$ , unless otherwise specified) (Note 1)

PARAMETER	TEST CONDITIONS	SYMBOL	MIN.	TYP.	MAX.	UNIT
Input Voltage (DDR1/2) (Note2)	Keep operate $V_{CNTL} \geq V_{IN}$ at power on and off sequences	$V_{IN}$	1.6	2.5	6	V
		$V_{CNTL}$	3.0	3.3	6	
Output Voltage	$I_{OUT} = 0mA$	$V_{OUT}$		$V_{REF}$		V
Output Voltage Offset	$I_{OUT} = 0mA$	$V_{OS}$	-20		20	mV
Load Regulation (DDR1/2) (Note2)	$I_{OUT} = 0.1mA \sim +3A$	$\Delta V_{LOR}$		35	45	mV
	$I_{OUT} = 0.1mA \sim -3A$			35	45	
Quiescent Current	$V_{REF} < 0.2V$ , $V_{OUT} = OFF$	$I_Q$		8	30	$\mu A$
Operating Current of $V_{CNTL}$	No load	$I_{CNTL}$		3	10	mA
$V_{REF}$ Bias Current	$V_{REF} = 1.25V$		0		1	$\mu A$
Current Limit		$I_{IL}$	3.2	4	6.5	A
<b>THERMAL PROTECTION</b>						
Thermal Shutdown Temperature	$3.3V \leq V_{CNTL} \leq 5V$	$T_{SD}$	125	150		$^\circ C$
Thermal Shutdown Hysteresis	Guaranteed by design			30		$^\circ C$
<b>SHUTDOWN SPECIFICATIONS</b>						
Shutdown Threshold	Output ON ( $V_{REF}=0V \rightarrow 1.25V$ )		0.8			V
	Output OFF ( $V_{REF}=1.25V \rightarrow 0V$ )			0.2		

Note 1: Specifications are production tested at  $T_A=25^\circ C$ . Specifications over the  $-40^\circ C$  to  $85^\circ C$  operating temperature range are assured by design, characterization and correlation with Statistical Quality Controls (SQC).

Note 2: DDR2 is not available for TO-263 package.

Note 3:  $V_{OS}$  is the voltage measurement, which is defined as  $V_{OUT}$  subtracted  $V_{REF}$ .

Note 4: Load regulation is measured at constant junction temperature, using pulse testing with a low ON time.

Note 5: Current limit is measured by pulsing a short time.

Note 6: For operate system safely;  $V_{CNTL}$  must be always greater than  $V_{IN}$ .

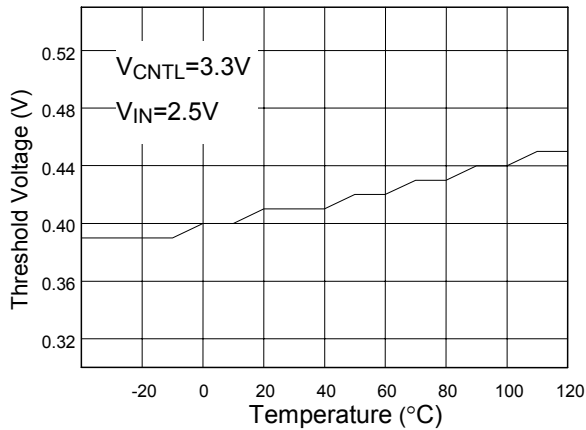
**TYPICAL PERFORMANCE CHARACTERISTICS**


Fig. 1 Turn-On Threshold vs. Temp.

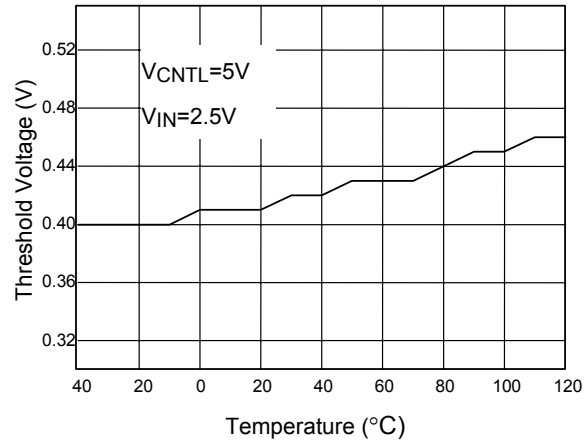


Fig. 2 Turn On Threshold vs. Temp.

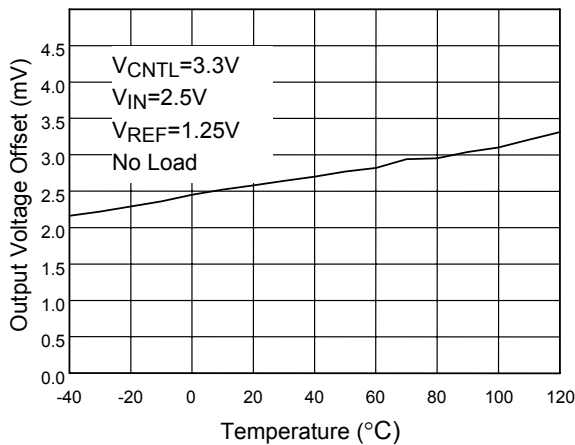


Fig. 3 Output Voltage Offset vs. Temp.

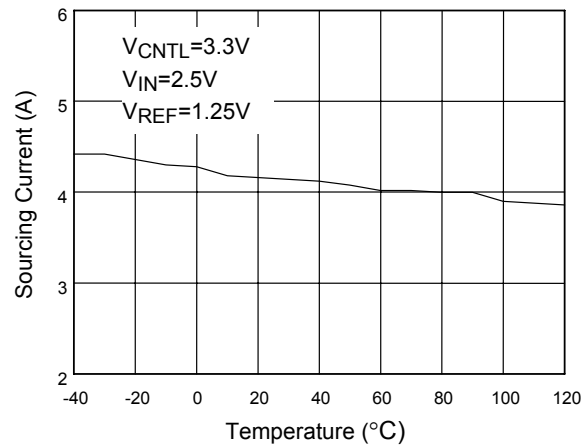


Fig. 4 Current-Limit (Sourcing) vs. Temp.

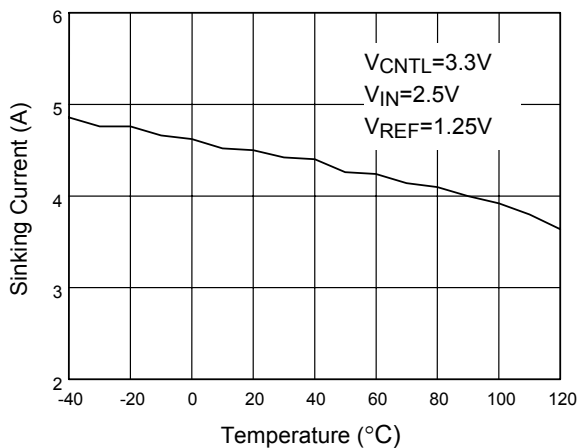
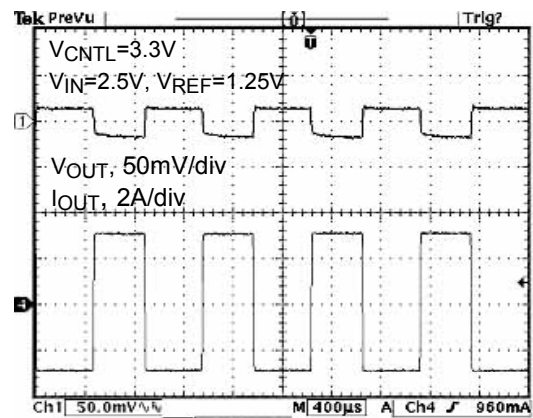


Fig. 5 Current-Limit (Sinking) vs. Temp.


 Fig. 6 Transient Response at 1.25V<sub>TT</sub>/3A

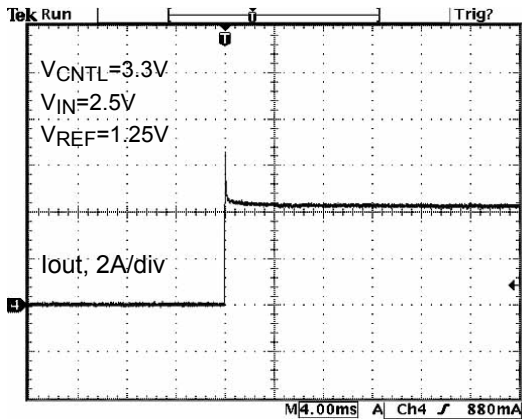
**TYPICAL PERFORMANCE CHARACTERISTICS (Continued)**


Fig. 7 Output Short-Circuit Protection (Sinking)

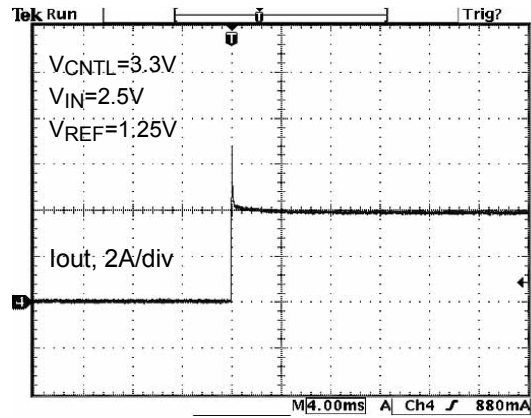
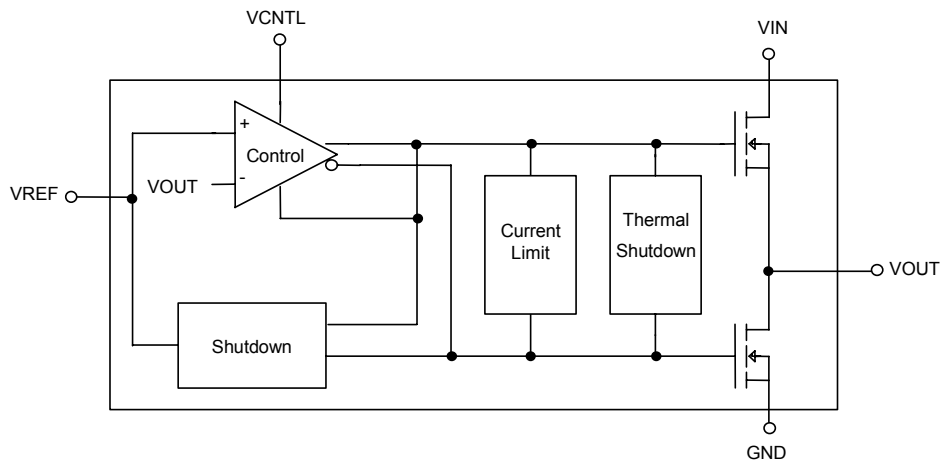


Fig. 8 Output Short-Circuit Protection (Sourcing)

**BLOCK DIAGRAM**


## ■ PIN DESCRIPTIONS

PIN 1: VIN - Input supply pin. It provides main power to create the external reference voltage by divider resistors for regulating  $V_{REF}$  and  $V_{OUT}$ .

PIN 2: GND - Ground pin.

PIN 3: VCNTL - Input supply pin. It is used to supply all the internal control circuitry.

PIN 4: VREF - Reference voltage input. Pull this pin low to shutdown device.

PIN 5: VOUT - Output pin.

## ■ APPLICATION INFORMATION

### *Layout Consideration*

AIC1383B is in SO-8 (DDR1/2), TO-252-5 (DDR1/2) and TO-263-5 (DDR1) packages resulting in unable to dissipate heat easily when it operates in high current. In order to prevent maximum junction temperature exceeded, the suitable copper area has to use.

The large copper at  $V_{CNTL}$  pins is available, and the heat dissipation is relieved. Using via to lead heat into the bottom layer to strengthen as below figures show.

All capacitors should be placed as close as possible to relative pins.

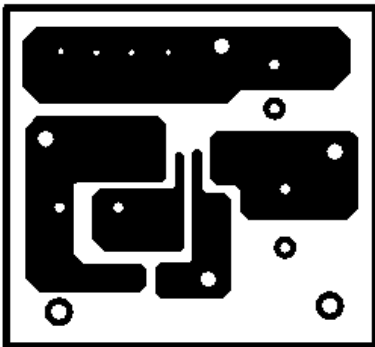


Fig. 9 Top layer of SO-8

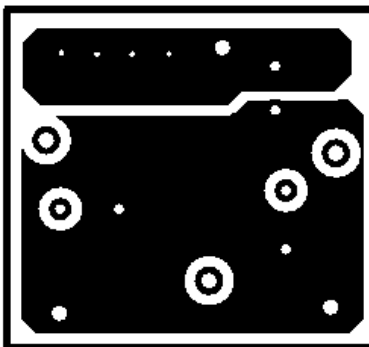


Fig. 10 Bottom layer of SO-8

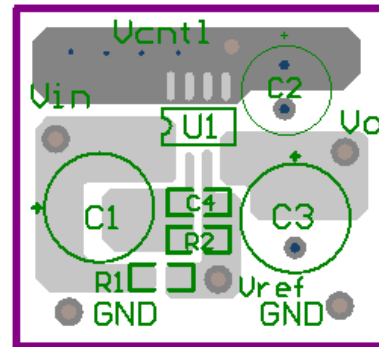
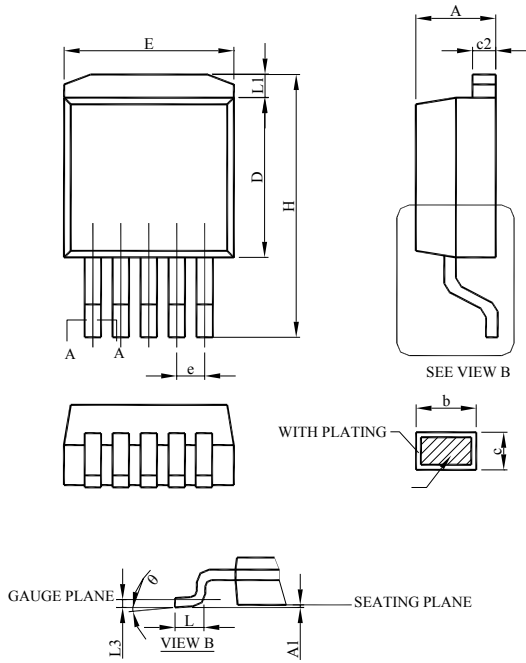
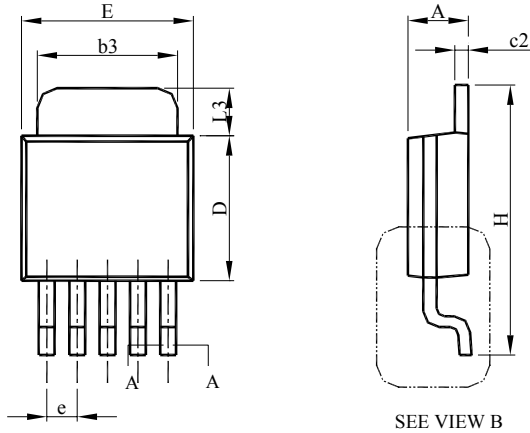


Fig. 11 Placement of SO-8

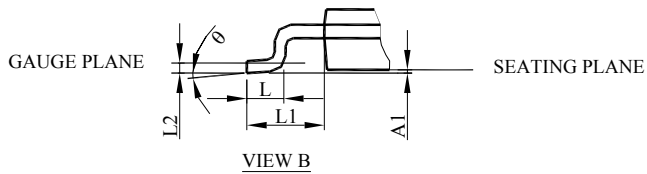
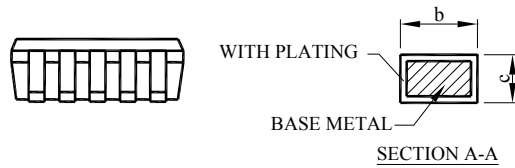
**■ PHYSICAL DIMENSIONS (unit: mm)**
**● TO-263-5**


TO-263-5L		
MILLIMETERS		
SYMBOL	MIN.	MAX.
A	4.06	4.83
A1	0.00	0.25
b	0.51	0.99
c	0.38	0.74
c2	1.14	1.65
D	8.38	9.65
E	9.65	10.67
e	1.70 BSC	
H	14.61	15.88
L	1.78	2.79
L1	--	1.68
L3	0.25 BSC	
θ	0°	8°

- TO-252-5

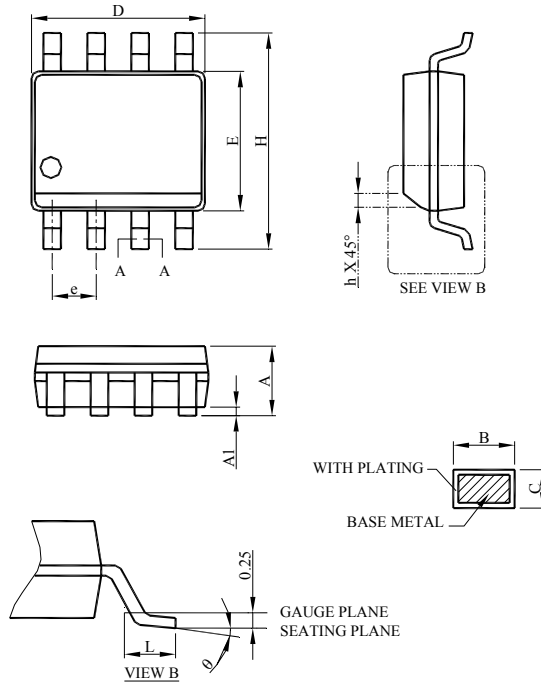


SYMBOL	TO-252-5L	
	MILLIMETERS	
	MIN.	MAX.
A	2.19	2.38
A1	0.00	0.13
b	0.51	0.71
b3	4.32	5.46
c	0.46	0.61
c2	0.46	0.89
D	5.33	6.22
E	6.35	6.73
e	1.27 BSC	
H	9.40	10.41
L	1.40	1.78
L1	2.67 REF	
L2	0.51 BSC	
L3	0.89	2.03
θ	0°	8°





- SOP-8



SYMBOL	SOP-8	
	MILLIMETERS	
	MIN.	MAX.
A	1.35	1.75
A1	0.10	0.25
B	0.33	0.51
C	0.19	0.25
D	4.80	5.00
E	3.80	4.00
e	1.27 BSC	
H	5.80	6.20
h	0.25	0.50
L	0.40	1.27
$\theta$	0°	8°

**Note:**

Information provided by AIC is believed to be accurate and reliable. However, we cannot assume responsibility for use of any circuitry other than circuitry entirely embodied in an AIC product; nor for any infringement of patents or other rights of third parties that may result from its use. We reserve the right to change the circuitry and specifications without notice.

Life Support Policy: AIC does not authorize any AIC product for use in life support devices and/or systems. Life support devices or systems are devices or systems which, (i) are intended for surgical implant into the body or (ii) support or sustain life, and whose failure to perform, when properly used in accordance with instructions for use provided in the labeling, can be reasonably expected to result in a significant injury to the user.