

High Performance, Tripple-Ouput, Auto-Tracking Combo Controller

■ FEATURES

- Provide Triple Accurate Regulated Voltages
- Optimized Voltage-Mode PWM Control
- Dual N-Channel MOSFET Synchronous Drivers
- Fast Transient Response
- Adjustable Over Current Protection using $R_{DS(on)}$. No External Current Sense Resistor Required.
- Programmable Softstart Function
- 200KHz Free-Running Oscillator
- Robust Outputs Auto-Tracking Characteristics
- Sink and Source Capabilities with External Circuit

■ APPLICATIONS

- Advanced PC Mboards
- Information PCs
- Servers and Workstations
- Internet Appliances
- PC Add-On Cards
- DDR Termination.

■ GENERAL DESCRIPTION

The AIC1340 combines a synchronous voltage mode PWM controller with a low dropout linear regulator and a linear controller as well as the monitoring and protection functions in this chip. The PWM controller regulates the output voltage with a synchronous rectified step-down converter. The built-in N-Channel MOSFET drivers also help to simplify the design of step-down converter. It is able to power CPUs, GPUs, memories, and chipsets. The PWM controller features over current protection using $R_{DS(on)}$. It improves efficiency and saves cost, as there is no expensive current sense resistor required.

The built-in adjustable linear controller drives an external MOSFET to form a linear regulator that regulates power for system I/O. The built-in adjustable low dropout linear regulator can supply current up to 500mA for supplying another system I/O. Output voltage of both linear regulators can also be adjusted by means of the external resistor divider. Both linear regulators feature current limit. With higher load current required from the low dropout linear regulator, the AIC1341 is recommended.

The Shutdown function is also provided for disable the combo controller.

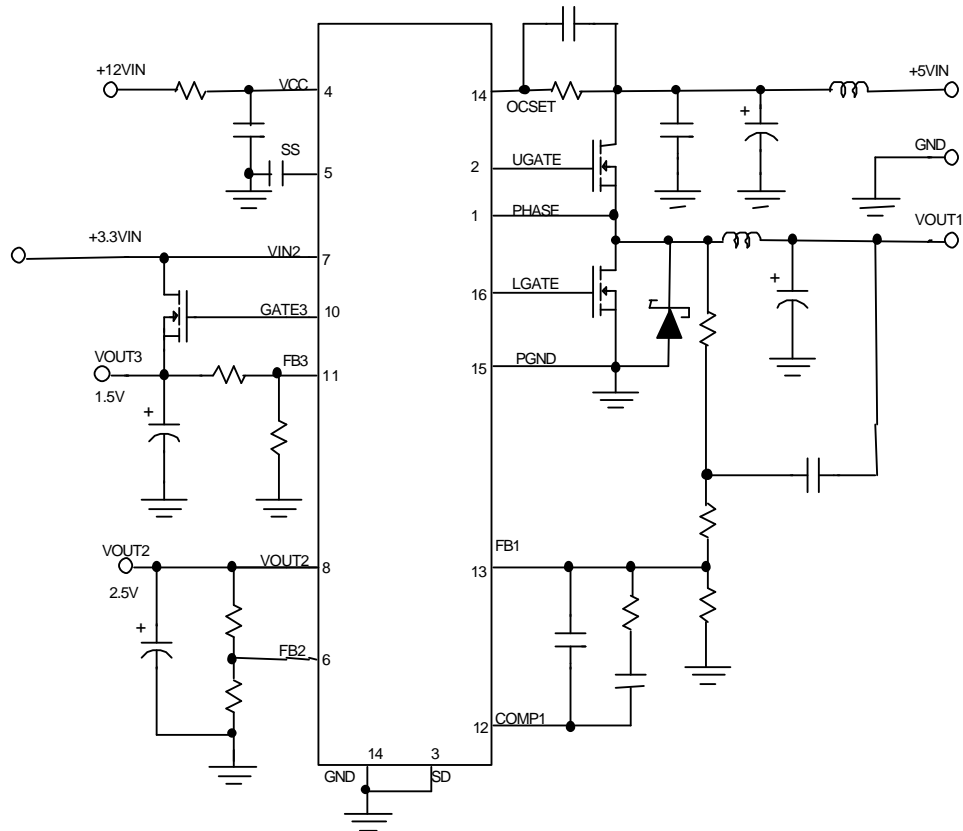
TYPICAL APPLICATION CIRCUIT

Typical Triple-Output Application
ORDERING INFORMATION

AIC1340-XX

 PACKAGING TYPE
 S: SMALL OUTLINE

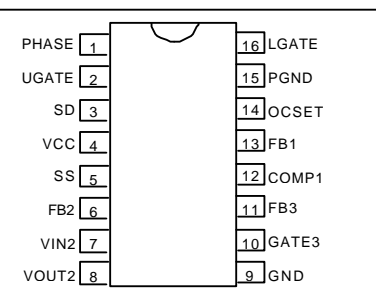
 TEMPERATURE RANGE
 C: 0°C~+70°C

ORDER NUMBER	PIN CONFIGURATION
AIC1340CS (SO16)	

■ ABSOLUTE MAXIMUM RATING**Absolute Maximum Ratings**

Supply Voltage (VCC).....	15V
UGATE.....	GND - 0.3V to VCC + 0.3V
LGATE.....	GND - 0.3V to VCC + 0.3V
Input Output and I/O Voltage.....	GND - 0.3V to 7V

Operating Conditions

Ambient Temperature Range.....	0° C to 85°C
Maximum Operating Junction Temperature.....	100°C
Supply Voltage, VCC.....	15V±10%

Thermal Information

Thermal Resistance θ_{JA} (°C/W)	
SOIC Package.....	100°C/W
Maximum Junction Temperature (Plastic Package).....	150°C
Maximum Storage Temperature Range.....	-65°C to 150°C
Maximum Lead Temperature (Soldering 10s).....	300°C

■ TEST CIRCUIT

Refer to APPLICATION CIRCUIT.

ELECTRICAL CHARACTERISTICS ($V_{CC}=12V$, $T_J=25^\circ C$, Unless otherwise specified)

PARAMETER	TEST CONDITIONS	SYMBOL	MIN.	TYP.	MAX.	UNIT
VCC SUPPLY CURRENT						
Supply Current	UGATE, LGATE, GATE3 and VOUT2 open	I_{CC}		1.8	3	mA
POWER ON RESET						
Rising VCC Threshold	$V_{OCSET}=4.5V$	$V_{CC_{THR}}$	8.6	9.5	10.4	V
Falling VCC Threshold	$V_{OCSET}=4.5V$	$V_{CC_{THF}}$	8.2	9.2	10.2	V
Rising VIN2 Under-Voltage Threshold		$V_{IN2_{THR}}$	2.5	2.6	2.7	V
VIN2 Under-Voltage Hysteresis		$V_{IN2_{HYS}}$		130		mV
Rising V_{OCSET1} Threshold		V_{OCSETH}		1.3		V
OSCILLATOR						
Free Running Frequency		F	170	200	230	KHz
Ramp. Amplitude		ΔV_{OSC}		1.3		V_{P-P}
REFERENCE						
FB2 Reference Voltage		V_{REF2}	1.240	1.265	1.290	V
FB3 Reference Voltage		V_{REF3}	1.250	1.275	1.300	V
LINEAR REGULATOR						
Regulation	$10mA < I_{OUT2} < 150mA$		-1		+1	%
Under-Voltage Level	FB2 falling	$FB2_{UV}$		70	82	%
Over-Current Protection			430	570		mA
Over-Current Protection During Start-up				750		mA
LINEAR CONTROLLER						
Regulation	$0 < I_{GATE3} < 10mA$		-2.5		+2.5	%
Under-Voltage Level	FB3 falling	$FB3_{UV}$		70	80	%

ELECTRICAL CHARACTERISTICS (Continued)

PARAMETER	TEST CONDITIONS	SYMBOL	MIN.	TYP.	MAX.	UNIT
PWM CONTROLLER ERROR AMPLIFIER						
DC GAIN				76		dB
Gain Bandwidth Product		GBWP		11		MHz
Slew Rate	COMP1=10pF	SR		6		V/μS
PWM CONTROLLER GATE DRIVER						
Upper Drive Source	VCC=12V, V _{UGATE} =11V	R _{UGH}		5.2	6.5	Ω
Upper Drive Sink	VCC=12V, V _{UGATE} =1V	R _{UGL}		3.3	5	Ω
Lower Drive Source	VCC=12V, V _{LGATE} =11V	R _{LGH}		4.1	6	Ω
Lower Drive Sink	VCC=12V, V _{LGATE} =1V	R _{LGL}		3	5	Ω
PROTECTION						
OCSET Current Source	V _{OCSET} =4.5V _{DC}	I _{OCSET}	170	200	230	μA
Soft-Start Current		I _{SS}		11		μA
Chip Shutdown Soft Start Threshold					1.0	V

PIN DESCRIPTIONS

Pin 1: PHASE: Over-current detection pin. Connect the PHASE pin to source of the external high-side N-MOSFET. This pin detects the voltage drop across the high-side N-MOSFET R_{DS(ON)} for over-current protection.

Pin 2: UGATE: External high-side N-MOSFET gate drive pin. Connect UGATE to gate of the external high-side N-MOSFET.

Pin 3: SD: To shut down the system, active high or floating.

Pin 4: VCC: The chip power supply pin. It also

provides the gate bias charge for all the MOSFETs controlled by the IC. Recommended supply voltage is 12V.

Pin 5: SS: Soft-start pin. Connect a capacitor from this pin to ground. This capacitor, along with an internal 10μA (typically) current source, sets the soft-start interval of the converter. Pulling this pin low will shut down the IC.

Pin 6: FB2: Connect this pin to a resistor divider to set the linear regulator output voltage.

Pin 7: VIN2: This pin supplies power to the internal regulator. Connect this pin to a suitable 3.3V source.

Additionally, this pin is used to monitor the 3.3V supply. If, following a start-up cycle, the voltage drops below 2.6V (typically), the chip shuts down. A new soft-start cycle is initiated upon return of the 3.3V supply above the under-voltage threshold.

Pin 8: VOUT2: Output of the linear regulator. Supplies current up to 500mA.

Pin 9: GND: Signal GND for IC. All voltage levels are measured with respect to this pin.

Pin 10: GATE3: Linear Controller output drive pin. This pin can drive either a Darlington NPN transistor or a N-channel MOSFET.

Pin 11: FB3 Negative feedback pin for the linear controller error amplifier connect this pin to a resistor divider to set the linear controller output voltage.

Pin 12: COMP1 External compensation pin. This

pin is connected to error amplifier output and PWM comparator. An RC network is connected to FB1 in to compensate the voltage control feedback loop of the converter.

Pin 13: FB1 The error amplifier inverting input pin. the FB1 pin and COMP1 pin are used to compensate the voltage-control feedback loop.

Pin 14: OCSET: Current limit sense pin. Connect a resistor R_{OCSET} from this pin to the drain of the external high-side N-MOSFET. R_{OCSET} , an internal 200 μ A current source (I_{OCSET}), and the upper N-MOSFET on-resistance ($R_{DS(ON)}$) set the over-current trip point according to the following equation:

$$I_{PEAK} = \frac{I_{OCSET} \times R_{OCSET}}{R_{DS(ON)}}$$

Pin 15: PGND: Driver power GND pin. PGND should be connected to a low impedance ground plane in close to lower N-MOSFET source.

Pin 16: LGATE: Lower N-MOSFET gate drive pin.

■ PACKAGE DIMENSIONS

- 16 LEAD PLASTIC SO (300 mil) (unit: mm)

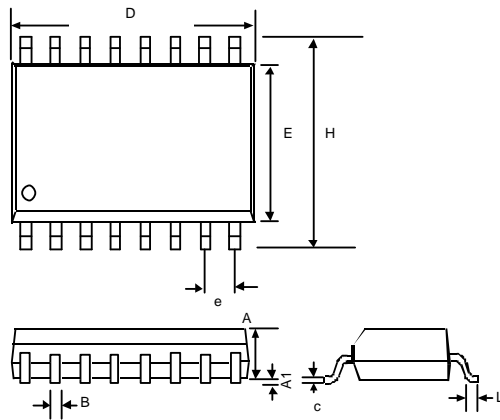

SYMBOL	MIN	MAX
A	2.35	2.65
A1	0.10	0.30
B	0.33	0.51
C	0.23	0.32
D	10.10	10.50
E	7.40	7.60
e	1.27(TYP)	
H	10.00	10.65
L	0.40	1.27