

XC74WL14AASR



CMOS Logic

- ◆ CMOS Logic Triple Schmit Inverter
- ◆ Operating Voltage Range : 2V ~ 5.5V
- ◆ High Speed Operations : tpd = 2.3ns TYP
- ◆ Low Power Consumption : 1μA (max)
- ◆ MSOP-8B Package

■ Description

XC74WL14AASR is Triple Schmit Inverter manufactured using silicon gate CMOS processes. The small quiescent current, which is one of the features of the CMOS logic, gives way to high speed operations which enables LS-TTL.

With wave forming buffers connected internally, stabilized output can be achieved as the series offers high noise immunity.

As the series is integrated into a mini molded, MSOP-8B package, high density mounting is possible.

■ Applications

- Palmtops
- Digital Equipment

■ Features

- High Speed Operations : tpd = 2.3ns TYP (Vcc=5V)
- Operating Voltage Range: 2V ~ 5.5V
- Low Power Consumption: 1μA (max)
- Small Package : MSOP-8B

■ Pin Configuration

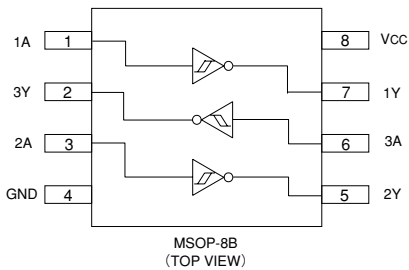

■ Functions

INPUT	OUTPUT
A	Y
H	L
L	H

H = High Level
L = Low Level

■ Absolute Maximum Ratings

Ta = -40°C ~ 85°C

PARAMETER	SYMBOL	RATINGS	UNITS
Power Supply Voltage	VCC	-0.5 ~ +6.0	V
Input Voltage	VIN	-0.5 ~ +6.0	V
Output Voltage	VOUT	-0.5 ~ VCC+0.5	V
Input Diode Current	I _{IK}	-20	mA
Output Diode Current	I _{OK}	±20	mA
Switch Output Current	I _{OUT}	±25	mA
VCC, GND Current	I _{CC} , I _{GND}	±50	mA
Power Dissipation (Ta=25°C)	P _d	300	mW
Storage Temperature	T _{stg}	-65 ~ +150	°C

Note : Voltage is all Ground standardized.

XC74WL14AASR

Recommended Operating Conditions

PARAMETER	SYMBOL	CONDITIONS	UNITS
Supply Voltage	VCC	2~5.5	V
Input Voltage	VIN	0~5.5	V
Output Voltage	VOUT	0~VCC	V
Operating Temperature	Topr	-40~+85	°C

DC Electrical Characteristics

PARAMETER	SYMBOL	Vcc (V)	CONDITIONS	Ta=25°C			Ta=-40~85°C		UNITS			
				MIN	TYP	MAX	MIN	MAX				
Threshold Voltage	VT+	3.0		—	—	2.20	—	2.20	V			
		4.5		—	—	3.15	—	3.15				
		5.5		—	—	3.85	—	3.85				
	VT-	3.0		0.90	—	—	0.90	—	V			
		4.5		1.35	—	—	1.35	—				
		5.5		1.65	—	—	1.65	—				
Hysteresis Voltage	VH	3.0		0.25	—	1.2	0.25	1.2	V			
		4.5		0.30	—	1.4	0.30	1.4				
		5.5		0.35	—	1.6	0.35	1.6				
Output Voltage	VOH	2.0	VIN=VIL	IOH=-50 μA	1.9	2.0	—	1.9	—	V		
		3.0			2.9	3.0	—	2.9	—			
		4.5			4.4	4.5	—	4.4	—			
		3.0			IOH=-4mA	2.58	—	—	2.48		—	
		4.5				IOH=-8mA	3.94	—	—		3.80	—
		5.5					—	—	—		—	—
	VOL	VIN=VIH	2.0	IOL=50 μA	—	—	0.1	—	0.1	V		
					3.0	—	—	0.1	—		0.1	
					4.5	—	—	0.1	—		0.1	
					3.0	IOL=4mA	—	—	0.36		—	0.44
							4.5	—	—		0.36	—
					4.5	IOL=8mA	—	—	0.36		—	0.44
5.5	—	—	0.36	—			0.44					
Input Current	IIN	0~5.5	VIN=VCC or GND	-0.1	—	0.1	-1.0	1.0	μA			
Quiescent Supply Current	ICC	5.5	VIN=VCC or GND, IOUT=0 μA	—	—	1.0	—	10.0	μA			

Switching Electrical Characteristics

(tr=tf=3ns)

PARAMETER	SYMBOL	CL	Vcc (V)	CONDITIONS	Ta=25°C			Ta=-40~85°C		UNITS
					MIN	TYP	MAX	MIN	MAX	
Propagation Delay Time	tPLH	15pF	3.3		—	2.8	12.8	1	15	ns
			5.0		—	2.1	8.6	1	10	
		50pF	3.3		—	4.3	16.3	1	18.5	ns
			5.0		—	3.1	10.6	1	12	
	tPHL	15pF	3.3		—	3.1	12.8	1	15	ns
			5.0		—	2.5	8.6	1	10	
		50pF	3.3		—	4.4	16.3	1	18.5	ns
			5.0		—	3.4	10.6	1	12	
Input Capacitance	CIN	—	5.0	VIN=VCC or GND	—	2	10	—	10	pF
Power Dissipation Capacitance	Cpd	No Load, f=1MHz			—	10	—	—	—	pF

13

XC74WL14AASR

Noise Characteristics

($t_r=t_f=3\text{ns}$)

PARAMETER	SYMBOL			CONDITIONS	Ta=25°C			UNITS
		CL	Vcc(V)		MIN	TYP	MAX	
Not functioning output maximum dynamic V_{OL}	V_{OLP}	50pF	5.0		—	0.3	0.8	V
Not functioning output minimum dynamic V_{OL}	V_{OLV}	50pF	5.0		-0.8	-0.3	—	V
Minimum dynamic V_{IH}	V_{IHD}	50pF	5.0		—	—	3.5	V
Maximum dynamic V_{IL}	V_{ILD}	50pF	5.0		—	—	1.5	V

Typical Application Circuit

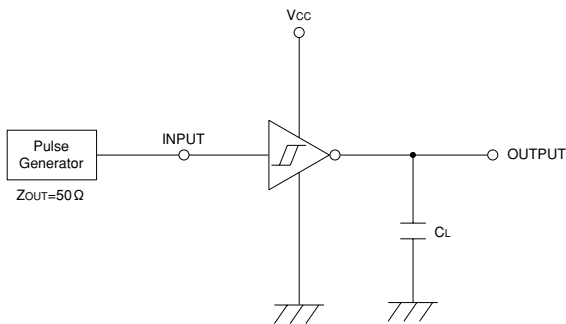

Waveforms

