

XC74WL125ASR



CMOS Logic

- ◆ CMOS Logic Dual Bus Buffer
- ◆ Operating Voltage Range : 2V ~ 5.5V
- ◆ High Speed Operations : tpd = 3.8ns TYP
- ◆ Low Power Consumption : 2μA (max)
- ◆ MSOP-8B Package

■ Description

XC74WL125ASR is Dual Bus Buffer manufactured using silicon gate CMOS processes. The small quiescent current, which is one of the features of the CMOS logic, gives way to high speed operations which enables LS-TTL.

With wave forming buffers connected internally, stabilized output can be achieved as the series offers high noise immunity.

As the series is integrated into a mini molded, MSOP-8B package, high density mounting is possible.

■ Applications

- Palmtops
- Digital Equipment

■ Features

- High Speed Operations : tpd = 3.8ns TYP (Vcc=5V)
- Operating Voltage Range: 2V ~ 5.5V
- Low Power Consumption: 2μA (max)
- Small Package : MSOP-8B

■ Pin Configuration

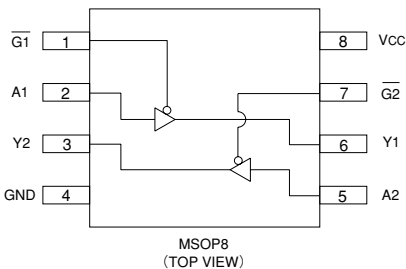

■ Functions

INPUT		OUTPUT
\bar{G}	A	Y
H	X	Z
L	H	H
L	L	L

H = High Level
L = Low Level
X = Don't care
Z = High Impedance

■ Absolute Maximum Ratings

Ta = -40°C ~ 85°C

PARAMETER	SYMBOL	RATINGS	UNITS
Power Supply Voltage	VCC	-0.5 ~ +6.0	V
Input Voltage	VIN	-0.5 ~ +6.0	V
Output Voltage	VOUT	-0.5 ~ VCC + 0.5	V
Input Diode Current	I _{IK}	-20	mA
Output Diode Current	I _{OK}	±20	mA
Switch Output Current	I _{OUT}	±25	mA
VCC, GND Current	I _{CC} , I _{IGND}	±50	mA
Power Dissipation (Ta=25°C)	P _d	300	mW
Storage Temperature	T _{stg}	-65 ~ +150	°C

Note : Voltage is all Ground standardized.

XC74WL125ASR

Recommended Operating Conditions

PARAMETER	SYMBOL	CONDITIONS	UNITS
Supply Voltage	VCC	2~5.5	V
Input Voltage	VIN	0~5.5	V
Output Voltage	VOUT	0~VCC	V
Operating Temperature	Topr	-40~+85	°C
Input Rise and Fall Time	tr, tf	0~200 (VCC=3.3V)	ns
		0~100 (VCC=5V)	

DC Electrical Characteristics

PARAMETER	SYMBOL	Vcc (V)	CONDITIONS	Ta=25°C			Ta=-40~85°C		UNITS		
				MIN	TYP	MAX	MIN	MAX			
Input Voltage	VIH	2.0		1.5	—	—	1.5	—	V		
		3.0		2.1	—	—	2.1	—			
		5.5		3.85	—	—	3.85	—			
	VIL	2.0		—	—	0.5	—	0.5	V		
		3.0		—	—	0.9	—	0.9			
		5.5		—	—	1.65	—	1.65			
Output Voltage	VOH	2.0	VIN=VIH	IOH=-50 μA	1.9	2.0	—	1.9	—	V	
		3.0			2.9	3.0	—	2.9	—		
		4.5		4.4	4.5	—	4.4	—			
		3.0		2.58	—	—	2.48	—			
	4.5	3.94	—	—	3.80	—					
	VOL	VIN=VIL	2.0	IOL=50 μA	—	—	0.1	—	0.1	V	
					3.0	—	—	0.1	—		0.1
			4.5		—	—	0.1	—	0.1		
			3.0		IOL=4mA	—	—	0.36	—		0.44
						IOL=8mA	—	—	0.36		—
4.5			IOL=8mA		—	—	0.36	—	0.44		
3 State Off-Leak Current	IOZ	5.0	VIN=VIL or VIH, Vout=VCC or GND	-0.25	—	0.25	-2.5	2.5	μA		
Input Current	IIN	0~5.5	VIN=VCC or GND	-0.1	—	0.1	-1.0	1.0	μA		
Quiescent Supply Current	ICC	5.5	VIN=VCC or GND	—	—	2.0	—	20.0	μA		

XC74WL125ASR

Switching Electrical Characteristics

(tr=tf=3ns)

PARAMETER	SYMBOL	VCC (V)	CONDITIONS	Ta=25°C			Ta=-40~85°C		UNITS
				MIN	TYP	MAX	MIN	MAX	
Propagation Delay Time	tPLH	3.3	CL=15pF	—	5.6	8	1	9.5	ns
		5.0		—	3.8	5.5	1	6.5	
		3.3	CL=50pF	—	8.1	11.5	1	13	ns
		5.0		—	5.3	7.5	1	8.5	
	tPHL	3.3	CL=15pF	—	5.6	8	1	9.5	ns
		5.0		—	3.8	5.5	1	6.5	
		3.3	CL=50pF	—	8.1	11.5	1	13	ns
		5.0		—	5.3	7.5	1	8.5	
Output Enable Time	tZL	3.3	RL=1kΩ	—	5.4	8	1	9.5	ns
		5.0	CL=15pF	—	3.6	5.1	1	6	
		3.3	RL=1kΩ	—	7.9	11.5	1	13	ns
		5.0	CL=50pF	—	5.1	7.1	1	8	
	tZH	3.3	RL=1kΩ	—	5.4	8	1	9.5	ns
		5.0	CL=15pF	—	3.6	5.1	1	6	
		3.3	RL=1kΩ	—	7.9	11.5	1	13	ns
		5.0	CL=50pF	—	5.1	7.1	1	8	
Output Disable Time	tLZ	3.3	RL=1kΩ	—	9.5	13.2	1	15	ns
		5.0	CL=50pF	—	6.1	8.8	1	10	
	tHZ	3.3	RL=1kΩ	—	9.5	13.2	1	15	ns
		5.0	CL=50pF	—	6.1	8.8	1	10	
Output Pin Skew (Note)	tosLH	3.3	CL=50pF	—	—	1.5	—	1.5	ns
		5.0		—	—	1	—	1	
	tosHL	3.3	CL=50pF	—	—	1.5	—	1.5	ns
		5.0		—	—	1	—	1	
Input Capacitance	CIN	—		—	4	10	—	10	pF
Output Capacitance	COUT	—		—	6	—	—	—	pF
Power Dissipation Capacitance	Cpd	—		—	14	—	—	—	pF

Note: tosLH and tosHL are the guaranteed parameters.
tosLH = | tPLHmin - tPHLmin |, tosHL = | tPHLmin - tPLHmin |

Noise Characteristics

(tr=tf=3ns)

PARAMETER	SYMBOL	CL	VCC(V)	CONDITIONS	Ta=25°C			UNITS
					MIN	TYP	MAX	
Not functioning output maximum dynamic VOL	VOLP	50pF	5.0		—	0.3	0.8	V
Not functioning output minimum dynamic VOL	VOLV	50pF	5.0		-0.8	-0.3	—	V
Minimum dynamic VIH	VIHD	50pF	5.0		—	—	3.5	V
Maximum dynamic VIL	VILD	50pF	5.0		—	—	1.5	V

XC74WL125ASR

■ Propagation Delay Time

■ Typical Application Circuit

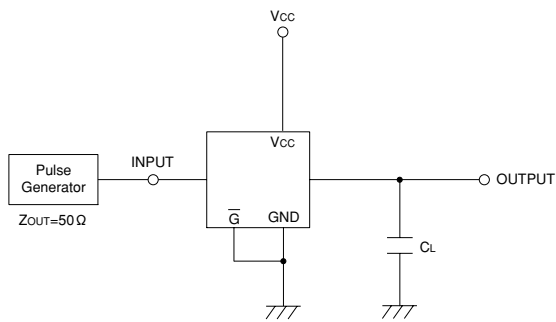

■ Waveforms

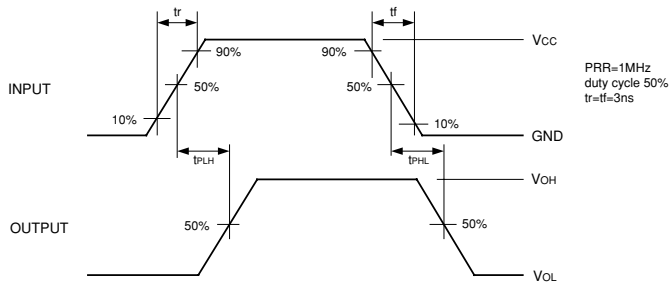

XC74WL125ASR

Output Enable Time, Output Disable Time

Typical Application Circuit

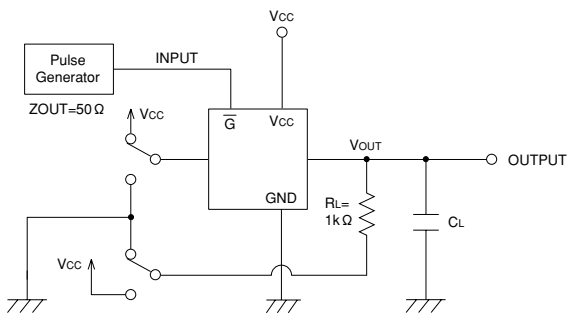

Waveforms

