

XC74WL04AASR



CMOS Logic

- ◆ CMOS Logic Triple Inverter
- ◆ Operating Voltage Range : 2V ~ 5.5V
- ◆ High Speed Operations : tpd = 2.05ns TYP
- ◆ Low Power Consumption : 1μA (max)
- ◆ MSOP-8B Package

Applications

- Palmtops
- Digital Equipment

Description

XC74WL04AASR is Triple Inverter manufactured using silicon gate CMOS processes. The small quiescent current, which is one of the features of the CMOS logic, gives way to high speed operations which enables LS-TTL.

With wave forming buffers connected internally, stabilized output can be achieved as the series offers high noise immunity.

As the series is integrated into a mini molded, MSOP-8B package, high density mounting is possible.

Features

- High Speed Operations : tpd = 2.05ns TYP (Vcc=5V)
- Operating Voltage Range: 2V ~ 5.5V
- Low Power Consumption: 1μA (max)
- Small Package : MSOP-8B

Pin Configuration

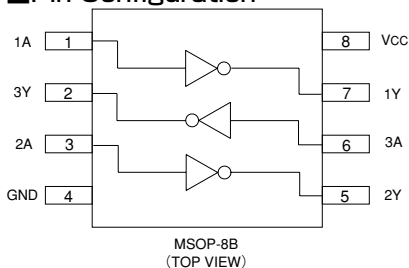

Functions

INPUT	OUTPUT
A	Y
H	L
L	H

H = High Level
L = Low Level

Absolute Maximum Ratings

Ta = -40°C ~ 85°C

PARAMETER	SYMBOL	RATINGS	UNITS
Power Supply Voltage	VCC	-0.5~+6.0	V
Input Voltage	VIN	-0.5~+6.0	V
Output Voltage	VOUT	-0.5~VCC+0.5	V
Input Diode Current	I _{IK}	-20	mA
Output Diode Current	I _{OK}	±20	mA
Switch Output Current	I _{OUT}	±25	mA
VCC, GND Current	I _{CC} , I _{IGND}	±50	mA
Power Dissipation (Ta=25°C)	P _d	300	mW
Storage Temperature	T _{stg}	-65~+150	°C

Note: Voltage is all Ground standardized.

XC74WLO4AASR

Recommended Operating Conditions

PARAMETER	SYMBOL	CONDITIONS	UNITS
Supply Voltage	VCC	2~5.5	V
Input Voltage	VIN	0~5.5	V
Output Voltage	VOUT	0~VCC	V
Operating Temperature	Topr	-40~+85	°C
Input Rise and Fall Time	tr, tf	0~200 (VCC=3.3V)	ns
		0~100 (VCC=5V)	

DC Electrical Characteristics

PARAMETER	SYMBOL	VCC (V)	CONDITIONS	Ta=25°C			Ta=-40~85°C		UNITS		
				MIN	TYP	MAX	MIN	MAX			
Input Voltage	VIH	2.0		1.5	—	—	1.5	—	V		
		3.0		2.1	—	—	2.1	—			
		5.5		3.85	—	—	3.85	—			
	VIL	2.0		—	—	0.5	—	0.5	V		
		3.0		—	—	0.9	—	0.9			
		5.5		—	—	1.65	—	1.65			
Output Voltage	VOH	2.0	VIN=VIL	IOH=-50 μA	1.9	2.0	—	1.9	—	V	
					3.0	2.9	3.0	—	2.9		—
					4.5	4.4	4.5	—	4.4		—
					3.0	2.58	—	—	2.48		—
					4.5	3.94	—	—	3.80		—
	VOL	2.0	VIN=VIH	IOL=50 μA	—	—	0.1	—	0.1	V	
					3.0	—	—	0.1	—		0.1
					4.5	—	—	0.1	—		0.1
					3.0	—	—	0.36	—		0.44
					4.5	—	—	0.36	—		0.44
Input Current	IIN	0~5.5	VIN=VCC or GND	-0.1	—	0.1	-1.0	1.0	μA		
Quiescent Ground Current	ICC	5.5	VIN=VCC or GND, IOUT=0 μA	—	—	1.0	—	10.0	μA		

Switching Electrical Characteristics

(tr=tf=3ns)

PARAMETER	SYMBOL	CL	VCC (V)	CONDITIONS	Ta=25°C			Ta=-40~85°C		UNITS
					MIN	TYP	MAX	MIN	MAX	
Propagation Delay Time	tPLH	15pF	3.3		—	2.7	7.1	1	8.5	ns
			5.0		—	2.1	5.5	1	6.5	
		50pF	3.3		—	4.1	10.6	1	12	ns
			5.0		—	3.2	7.5	1	8.5	
	tPHL	15pF	3.3		—	2.5	7.1	1	8.5	ns
			5.0		—	2.0	5.5	1	6.5	
50pF		3.3	—	3.9	10.6	1	12	ns		
		5.0	—	3.0	7.5	1	8.5			
Input Capacitance	CIN	—	5.0	VIN=VCC or GND	—	2	10	—	10	pF
Power Dissipation Capacitance	Cpd	—	No Load, F=1MHz	—	8.9	—	—	—	—	pF

13

XC74WLO4AASR

Noise Characteristics

($t_r=t_f=3\text{ns}$)

PARAMETER	SYMBOL	C _L	V _{CC} (V)	CONDITIONS	T _a =25°C			UNITS
					MIN	TYP	MAX	
Not functioning output maximum dynamic V _{OL}	V _{OLP}	50pF	5.0		—	0.3	0.8	V
Not functioning output minimum dynamic V _{OL}	V _{OLV}	50pF	5.0		-0.8	-0.3	—	V
Minimum dynamic V _{IH}	V _{IHD}	50pF	5.0		—	—	3.5	V
Maximum dynamic V _{IL}	V _{ILD}	50pF	5.0		—	—	1.5	V

Typical Application Circuit

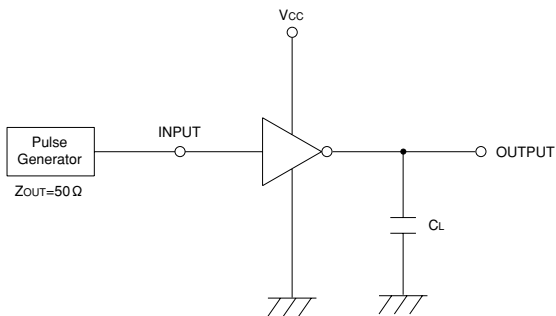

Waveforms

