

- ◆ CMOS Logic Analog Switch
- ◆ Operating Voltage Range 2V to 5.5V
- ◆ High Speed Operations $t_{pd} = 3\text{ns TYP}$
- ◆ Low Power Consumption $1\mu\text{A MAX}$
- ◆ Low ON Resistance $R_{on} = 22\Omega \text{ TYP}$

- Applications
 - Palmtops
 - Digital Equipment

■ Description

XC74UL4066M is CMOS Analog Switch manufactured using silicon gate CMOS processes. The small quiescent current, which is one of the features of the CMOS logic, gives way to high speed analog or digital signal switching.

As the series is integrated into a mini molded, SOT-25 package, high density mounting is possible.

■ Features

- High Speed Operations
 $t_{pd} = 3\text{ns TYP}$
- Operating Voltage Range
2V to 5.5V
- Low Power Consumption
 $1\mu\text{A MAX (Ta = 25}^\circ\text{C)}$
- Low ON Resistance
 $22\Omega \text{ TYP}$
- Small Package
SOT-25

■ Pin Configuration

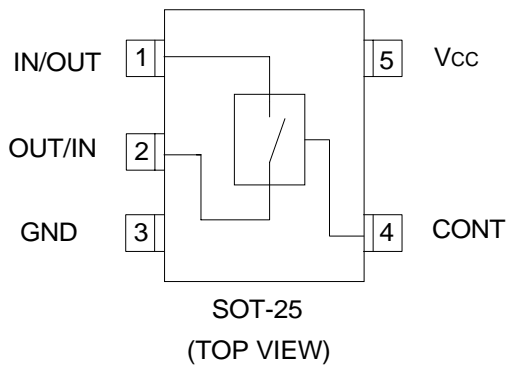

■ Functions

Control	State
L	OFF
H	ON

H = High Level
L = Low Level

■ Logic Diagram

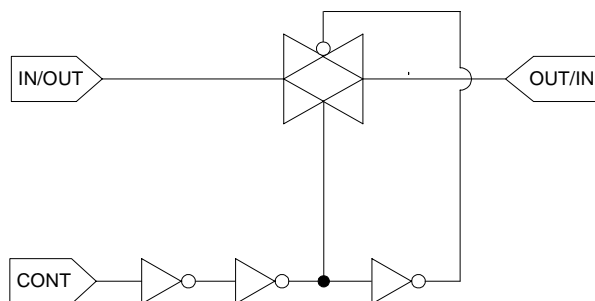

■ Absolute Maximum Ratings

Ta = -40°C ~ 85°C

PARAMETER	SYMBOL	RATINGS	UNITS
Power Supply Voltage	VCC	-0.5 ~ +6.0	V
Control Input Voltage	VCONT	-0.5 ~ +6.0	V
Switch Output Voltage	Vout	-0.5 ~ VCC +0.5	V
Control Input Diode Current	I _{IK}	-20	mA
Switch Output Diode Current	I _{OK}	±20	mA
Switch Output Current	I _{OUT}	±25	mA
VCC, GND Current	I _{CC} , I _{GND}	±50	mA
Power Dissipation (Ta = 25°C)	P _d	200	mW
Storage Temperature	T _{stg}	-65 ~ +150	°C

Note : Voltage is all Ground standardized.

■ Recommended Operating Conditions

PARAMETER	SYMBOL	V _{cc} (V)	RATINGS	UNITS
Supply Voltage	VCC	-	2 ~ 5.5	V
Input Voltage	V _{in}	-	0 ~ 5.5	V
Output Voltage	V _{out}	-	0 ~ VCC	V
Operating Temperature	T _{opr}	-	-40 ~ +85	°C
Input Rise and Fall Time	tr, tf	3.3	0 ~ 100	ns / V
		5.0	0 ~ 20	

■ DC Electrical Characteristics

PARAMETER	SYMBOL	V _{CC} (V)	CONDITIONS	Ta=25°C			Ta=-40 ~ 85°C		UNITS
				MIN	TYP	MAX	MIN	MAX	
"High" Level Control Input Voltage	VIH	2.0		1.5	-	-	1.5	-	V
		3.0		2.1	-	-	2.1	-	
		5.5		3.85	-	-	3.85	-	
"Low" Level Control Input Voltage	VIL	2.0		-	-	0.5	-	0.5	V
		3.0		-	-	0.9	-	0.9	
		5.5		-	-	1.65	-	1.65	
Peak ON Resistance	RONmax	2.0	VCONT=VIH	-	130	350	-	550	Ω
		3.0	Vin=0~VCC	-	22	50	-	65	
		4.5	Iin/out=1mA	-	12	25	-	35	
ON Resistance	RON(1)	2.0	VCONT=VIH	-	23	50	-	65	Ω
		3.0	Vin=GND or VCC	-	14	30	-	40	
		4.5	Iin/out=1mA	-	10	20	-	25	
Power Off Leakage Current	IS(OFF)	5.5	VCONT=VIL, Vin=VCC, Vout=GN	-	-	±0.1	-	±1.0	μA
Power On Leakage Current	IS(ON)	5.5	VCONT=VIH, Vin=VCC or GND	-	-	±0.1	-	±1.0	μA
Control Input Current	I _{CONT}	5.5	Vin=VCC or GND	-	-	±0.1	-	±1.0	μA
Quiescent Supply Current	I _{CC}	5.5	Vin=VCC or GND	-	-	1.0	-	5.0	μA

■ Switching Electrical Characteristics

(tr = tf = 3ns)

PARAMETER	SYMBOL	CONDITIONS		Ta=25°C			Ta=-40 ~ 85°C		UNITS	
		CL	VCC(V)	MIN	TYP	MAX	MIN	MAX		
Propagation Delay Time	tPLH	50pF	2.0	RL=10kΩ	-	4	20	-	23	ns
	tPHL		3.3		-	3	6	-	8	
			5.0		-	2	5	-	6	
Output Enable Time	tZL	50pF	2.0	RL=1kΩ	-	9	50	-	65	ns
	tZH		3.3		-	5	10	-	12	
			5.0		-	3	8	-	10	
Output Disable Time	tLZ	50pF	2.0	RL=1kΩ	-	12	60	-	75	ns
	tHZ		3.3		-	10	23	-	27	
			5.0		-	8	20	-	25	
Sine Wave Distortion Rate		50pF	3.0	RL=10kΩ fIN=1kHz	-	0.05	-	-	-	%
-3dB Band Width		50pF	3.0	RL=600kΩ $20\log_{10}\frac{V_{out}}{V_{in}} = -3dB$	-	200	-	-	-	MHz
Feed Through (Switch-off)		50pF	3.0	RL=600kΩ fIN=1MHz	-	-60	-	-	-	dB
Cross Talk (Control Switch)		50pF	2.0	RL=600kΩ fIN=1MHz	-	60	-	-	-	mV
			3.0		-	100	-	-	-	
			4.5		-	150	-	-	-	
Maximum Control Input Frequency		15pF	2.0	RL=1kΩ VOUT=VCC/2	-	30	-	-	-	MHz
			3.0		-	30	-	-	-	
			4.5		-	30	-	-	-	
Control Input Capacitance	Cin	-	-	-	5	-	-	-	pF	
Switch Input/Output Capacitance	Cin/out	-	-	-	6	10	-	10	pF	
Feed Through Capacitance	Cin-out	-	-	-	0.5	-	-	-	pF	
Power Dissipation Capacitance	CPD	-	-	-	13	-	-	-	pF	

Note: CPD is defined as the value of the internal equivalent capacitance which is derived from the operating supply current at times of "No Load".

Ensure that the average operating supply current at times of "No Load" meets the following conditions:
 $I_{CC} (opr) = CPD \cdot V_{CC} \cdot f_{IN} + I_{CC}$

■ Propagation Delay Time

■ Waveforms

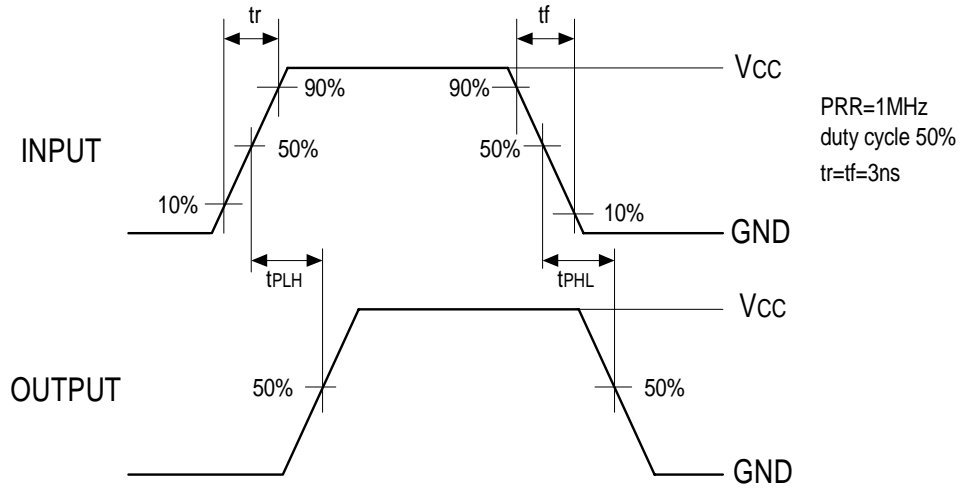

■ Test Circuits

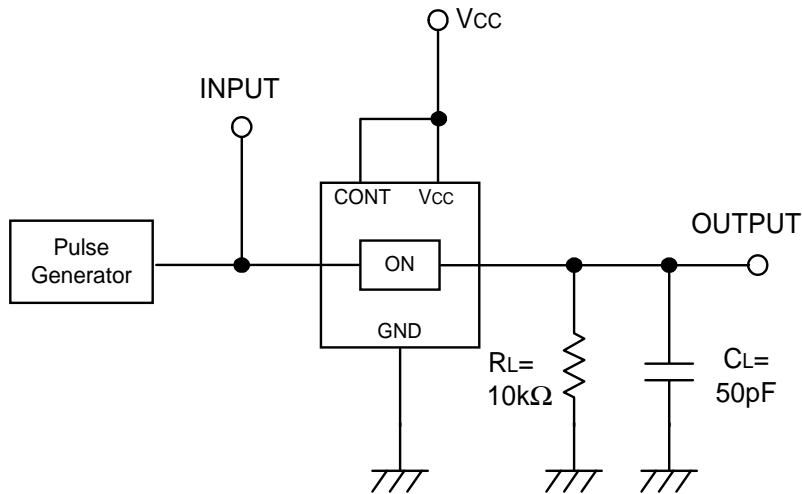

Note: open output when measuring supply current

■ Output Enable Time, Output Disable Time

■ Waveforms

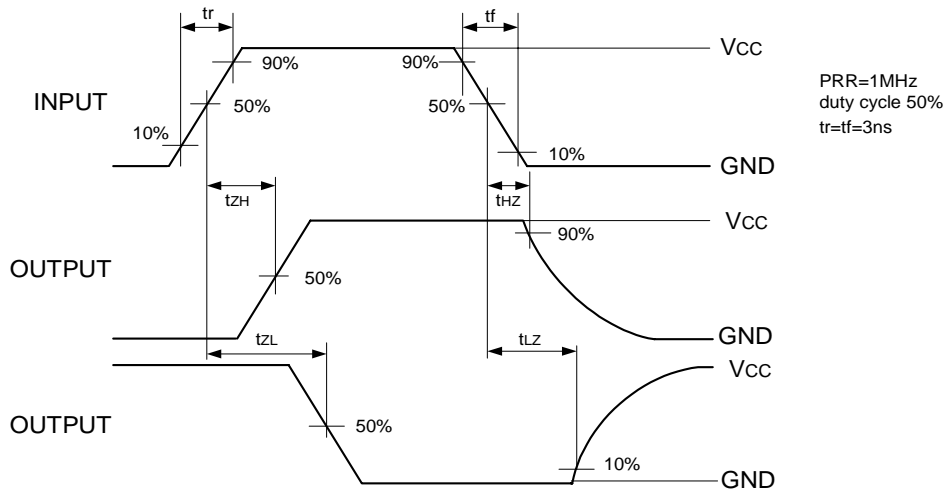

■ Test Circuits

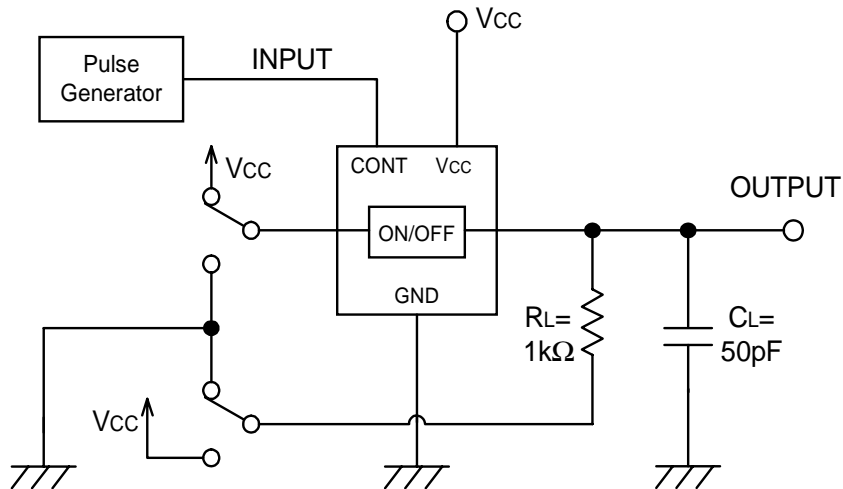

- Sine Wave Distortion Rate

- Test Circuits

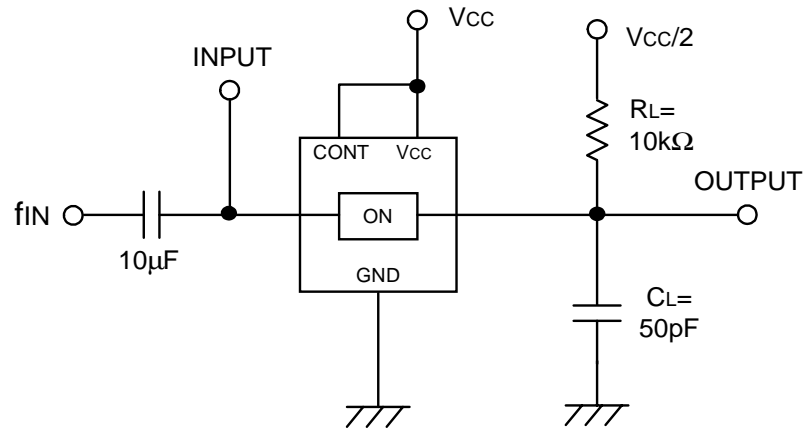

* Input by sine wave

- 3dB Band Width

- Test Circuits

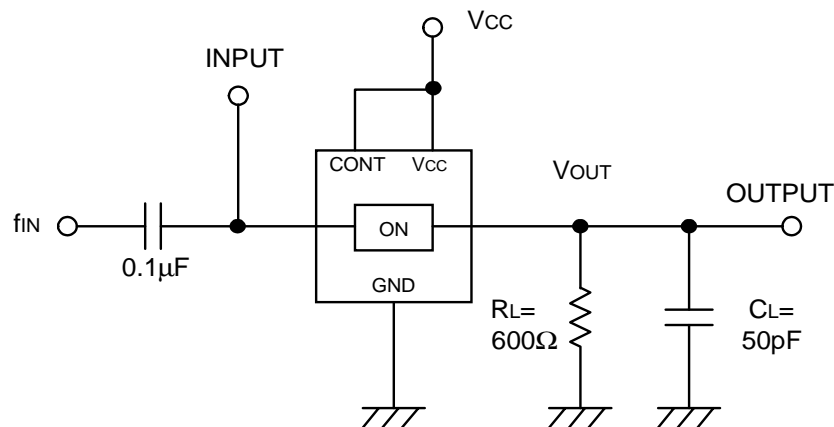

* Input by sine wave

■ Feed Through Test Circuits

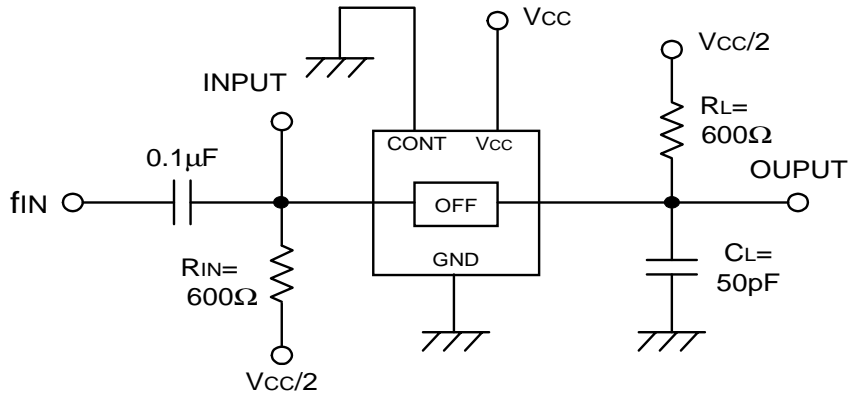

* Input by sine wave

■ Cross Talk

■ Waveforms

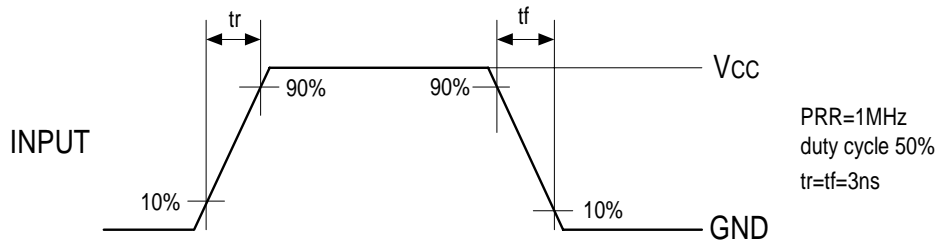

■ Test Circuits

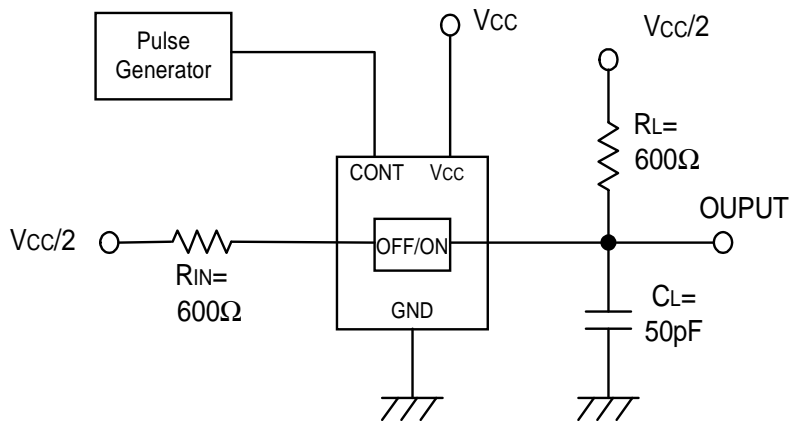

■ Maximum Control Input Frequency

■ Waveforms

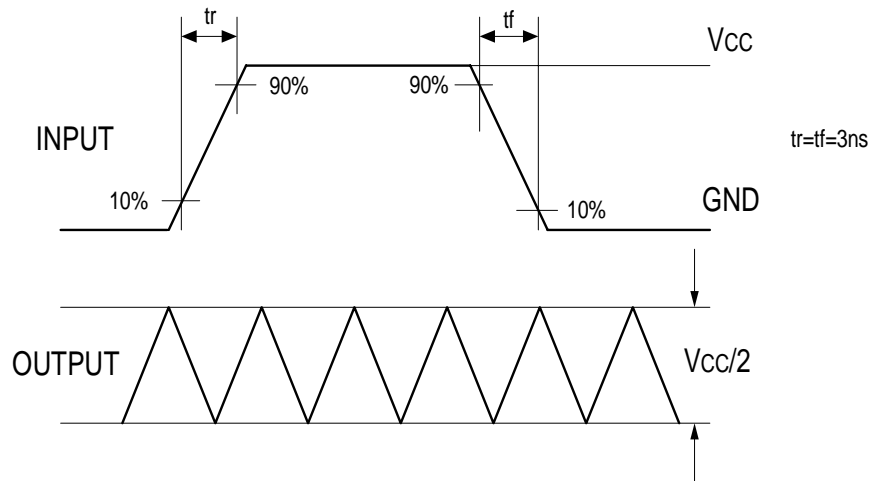

■ Test Circuits

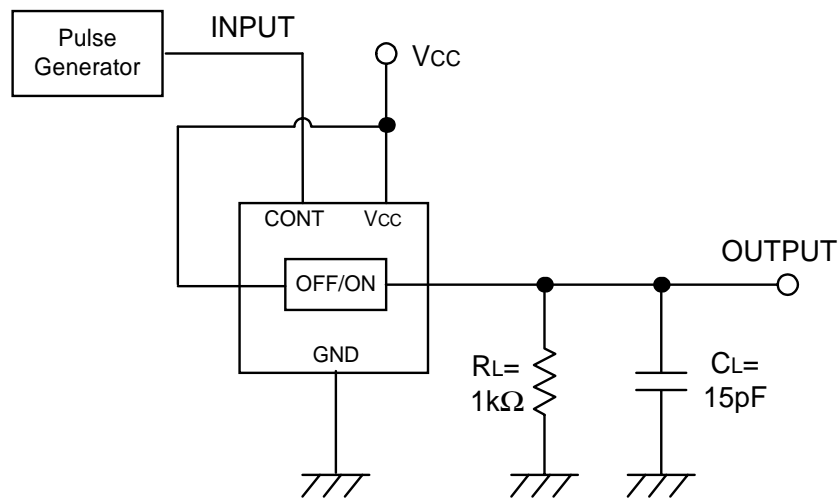

- On Resistance

- Test Circuits

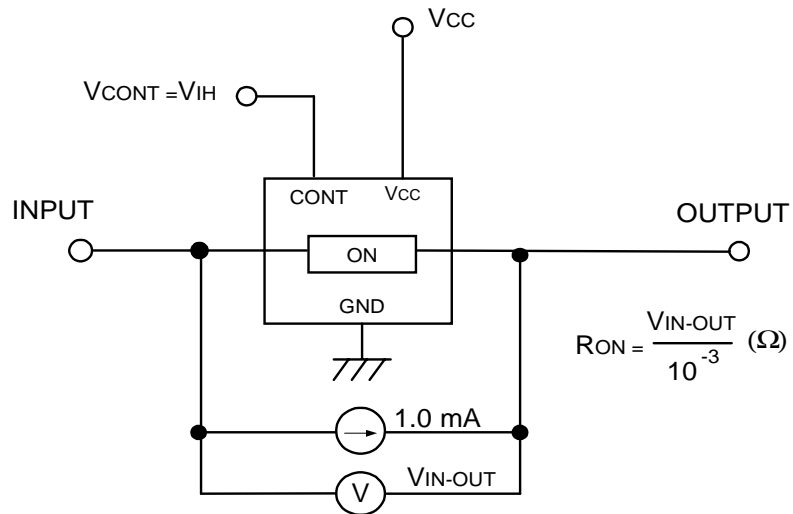

- Voltage Dependencies of ON Resistance

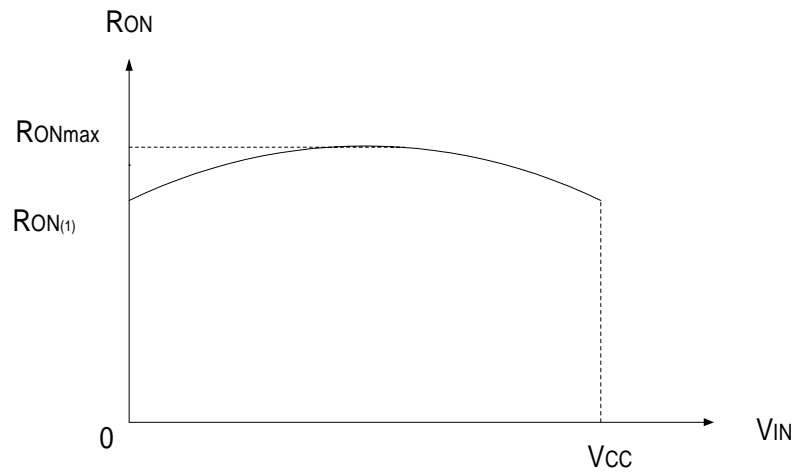

■ Power Off Leakage Current

■ Test Circuits

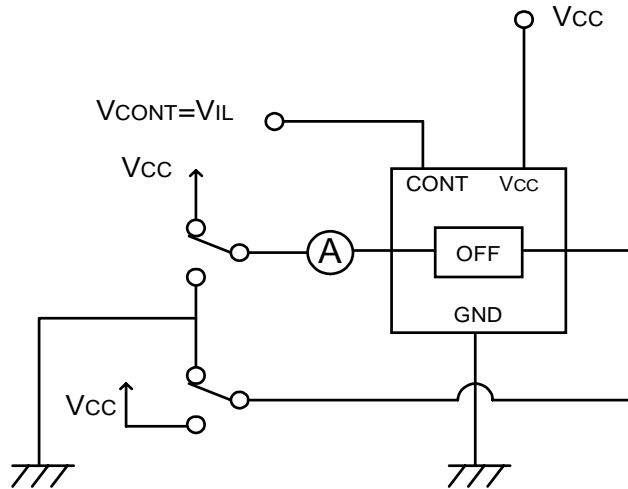

■ Power On Leakage Current

■ Test Circuits

