

## Very low drop voltage regulators with inhibit

### Features

- Very low dropout voltage (0.2 V typ)
- Very low quiescent current (typ. 50  $\mu$ A in OFF MODE, 0.5 mA in ON MODE, no load)
- Output current up to 100 mA
- Output voltages of 2.5; 2.7; 3; 3.3; 3.5; 4; 4.5; 4.7; 5; 8 V
- Internal current and thermal limit
- Only 2.2  $\mu$ F for stability
- Available in  $\pm 1\%$  (A) or  $\pm 2\%$  (C) selection at 25 °C
- Supply voltage rejection: 80 dB (typ.)
- Temperature range: -40 to 125 °C

### Description

The LExxAB and LExxC are very low drop voltage regulators available in SO-8 and TO-92 packages and in a wide range of output voltages.

The very low drop voltage (0.2 V) and the very low quiescent current make them particularly suitable for low noise low power applications and specially in battery powered systems.

They are pin to pin compatible with the older L78Lxx series. Furthermore in the 8 pin configuration (SO-8) they employ a shutdown logic control (pin 5, TTL compatible). This means that when the device is used as a local regulator,

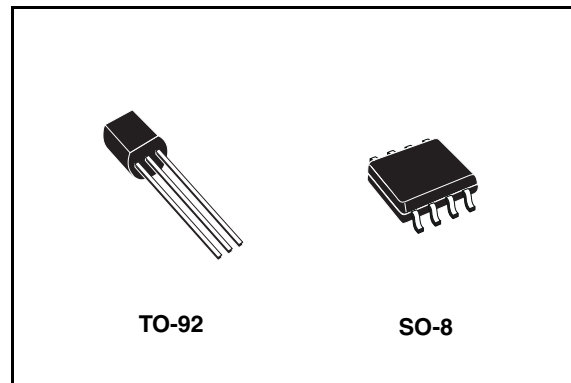

it's possible to put in stand by a part of the board even more decreasing the total power consumption. In the three terminal configuration (TO-92) the device is even in ON STATE, maintaining the same electrical performances. It needs only 2.2  $\mu$ F capacitor for stability allowing room and cost saving effect.

**Table 1. Device summary**

Part numbers		
LE25AB	LE35C	LE47AB
LE27AB	LE35AB	LE50C
LE30C	LE40C	LE50AB
LE33C	LE45C	LE80C
LE33AB	LE45AB	LE80AB

---

## Contents

1	Diagram .....	5
2	Pin configuration .....	6
3	Maximum ratings .....	7
4	Electrical characteristics .....	8
5	Typical performance characteristics .....	29
6	Package mechanical data .....	32
7	Order codes .....	37
8	Revision history .....	38

## List of figures

Figure 1.	Block diagram . . . . .	5
Figure 2.	Pin connections (top view for SO-8, bottom view for TO-92) . . . . .	6
Figure 3.	Test circuit . . . . .	7
Figure 4.	Dropout voltage vs output current. . . . .	29
Figure 5.	Dropout voltage vs temperature . . . . .	29
Figure 6.	Supply current vs temperature . . . . .	29
Figure 7.	Supply current vs input voltage. . . . .	29
Figure 8.	Short circuit current vs dropout voltage . . . . .	29
Figure 9.	SVR vs frequency . . . . .	29
Figure 10.	Logic controlled precision 3.3/5.0 V selectable output . . . . .	30
Figure 11.	Sequential multi-output supply . . . . .	30
Figure 12.	Multiple supply with ON/OFF toggle switch . . . . .	31
Figure 13.	Basic inhibit functions . . . . .	31

## List of tables

Table 1.	Device summary . . . . .	1
Table 2.	Absolute maximum ratings . . . . .	7
Table 3.	Thermal data . . . . .	7
Table 4.	Electrical characteristics for LE12AB . . . . .	8
Table 5.	Electrical characteristics for LE25AB . . . . .	9
Table 6.	Electrical characteristics for LE25C . . . . .	10
Table 7.	Electrical characteristics for LE27AB . . . . .	11
Table 8.	Electrical characteristics for LE27C . . . . .	12
Table 9.	Electrical characteristics for LE30AB . . . . .	13
Table 10.	Electrical characteristics for LE30C . . . . .	14
Table 11.	Electrical characteristics for LE33AB . . . . .	15
Table 12.	Electrical characteristics for LE33C . . . . .	16
Table 13.	Electrical characteristics for LE35AB . . . . .	17
Table 14.	Electrical characteristics for LE35C . . . . .	18
Table 15.	Electrical characteristics for LE40AB . . . . .	19
Table 16.	Electrical characteristics for LE40C . . . . .	20
Table 17.	Electrical characteristics for LE45AB . . . . .	21
Table 18.	Electrical characteristics for LE45C . . . . .	22
Table 19.	Electrical characteristics for LE47AB . . . . .	23
Table 20.	Electrical characteristics for LE47C . . . . .	24
Table 21.	Electrical characteristics for LE50AB . . . . .	25
Table 22.	Electrical characteristics for LE50C . . . . .	26
Table 23.	Electrical characteristics for LE80AB . . . . .	27
Table 24.	Electrical characteristics for LE80C . . . . .	28
Table 25.	Order codes . . . . .	37
Table 26.	Document revision history . . . . .	38

# 1 Diagram

Figure 1. Block diagram

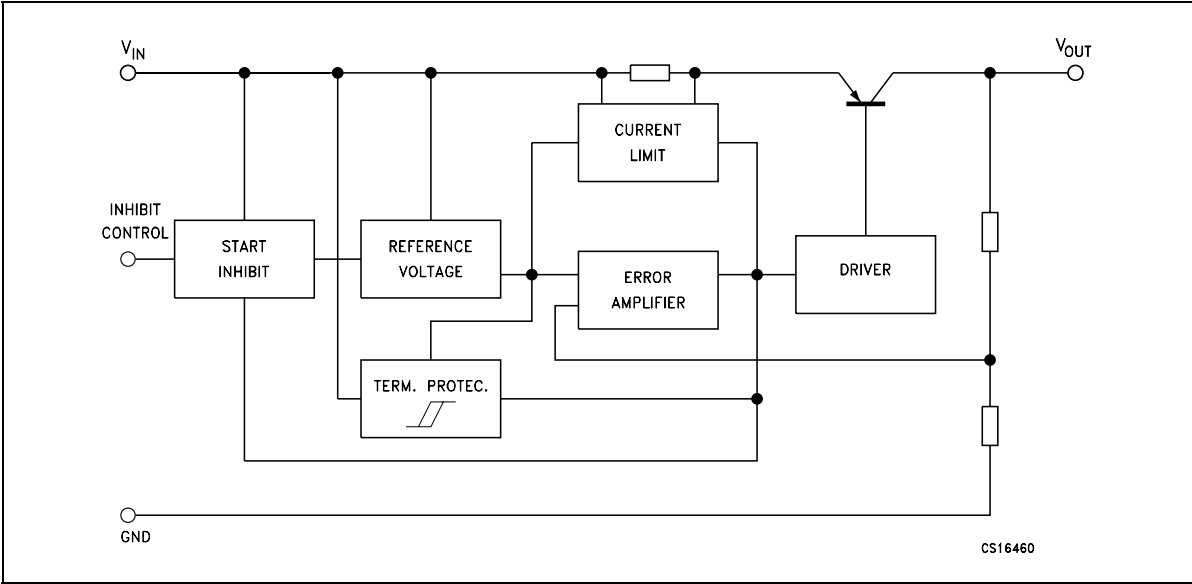

## 2 Pin configuration

Figure 2. Pin connections (top view for SO-8, bottom view for TO-92)

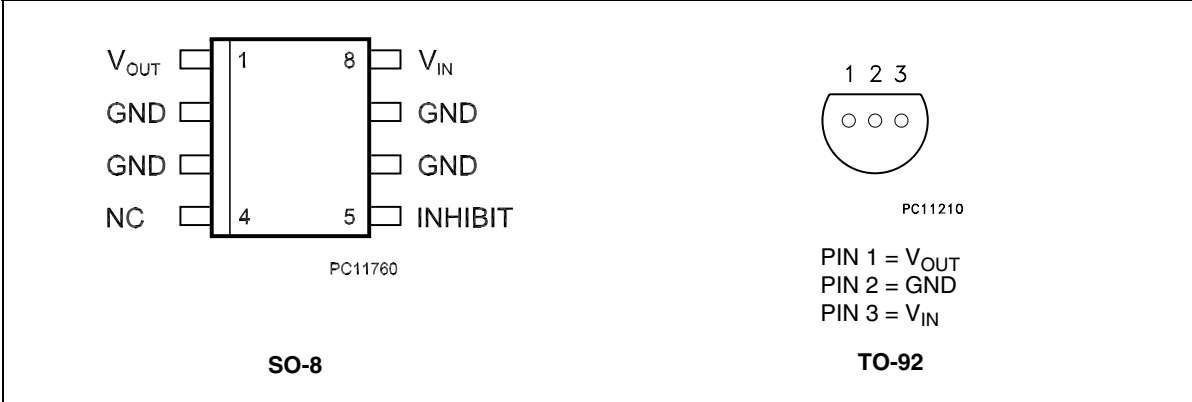

### 3 Maximum ratings

**Table 2. Absolute maximum ratings**

Symbol	Parameter	Value	Unit
$V_I$	DC input voltage	20	V
$I_O$	Output current	Internally limited <sup>(1)</sup>	
$P_{TOT}$	Power dissipation	Internally limited	
$T_{STG}$	Storage temperature range	-65 to 150	°C
$T_{OP}$	Operating junction temperature range	-40 to 125	°C

1. Our SO-8 package used for Voltage Regulators is modified internally to have pins 2, 3, 6 and 7 electrically communed to the die attach flag. This particular frame decreases the total thermal resistance of the package and increases its ability to dissipate power when an appropriate area of copper on the printed circuit board is available for heatsinking. The external dimensions are the same as for the standard SO-8.

**Table 3. Thermal data**

Symbol	Parameter	SO-8	TO-92	Unit
$R_{thJC}$	Thermal resistance junction-case	20		°C/W
$R_{thJA}$	Thermal resistance junction-ambient	55	200	°C/W

**Figure 3. Test circuit**

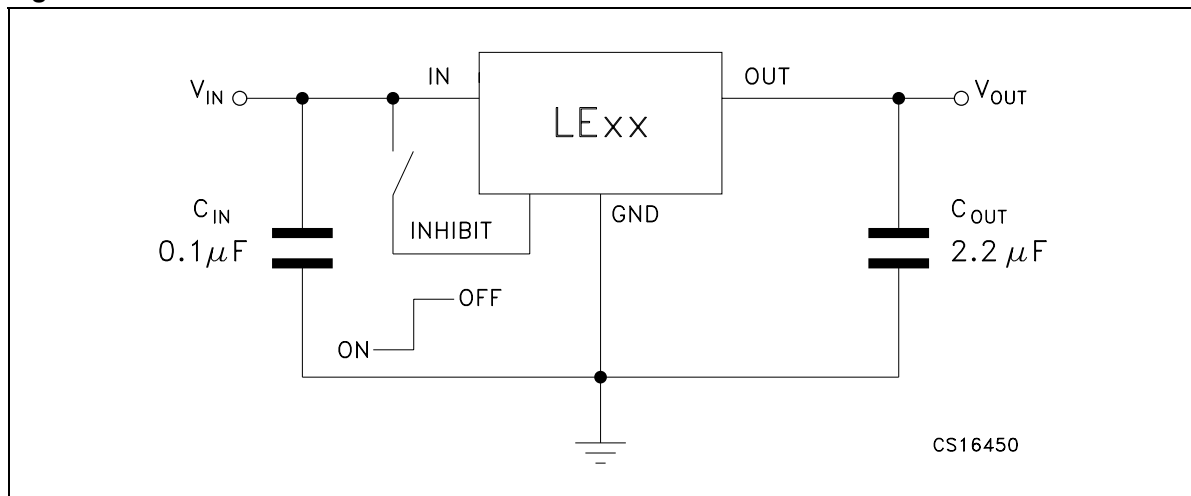

**Note:** *If the Inhibit pin is left floating, the regulator is in ON mode. However, to avoid any noise picking-up, it is suggested to ground it when the Inhibit function is not used.*

## 4 Electrical characteristics

**Table 4. Electrical characteristics for LE12AB** (refer to the test circuits,  $T_J = 25\text{ }^\circ\text{C}$ ,  $C_I = 0.1\text{ }\mu\text{F}$ ,  $C_O = 2.2\text{ }\mu\text{F}$  unless otherwise specified.)

Symbol	Parameter	Test conditions	Min.	Typ.	Max.	Unit
$V_O$	Output voltage	$I_O = 10\text{ mA}$ , $V_I = 3.3\text{ V}$	1.225	1.25	1.275	V
		$I_O = 10\text{ mA}$ , $V_I = 3.3\text{ V}$ , $T_A = -25\text{ to }85\text{ }^\circ\text{C}$	1.2		1.3	
$V_I$	Operating input voltage	$I_O = 100\text{ mA}$	2.5		18	V
$I_O$	Output current limit		150			mA
$\Delta V_O$	Line regulation	$V_I = 2.5\text{ to }18\text{ V}$ , $I_O = 0.5\text{ mA}$		3	15	mV
$\Delta V_O$	Load regulation	$V_I = 2.8\text{ V}$ , $I_O = 0.5\text{ to }100\text{ mA}$		3	15	mV
$I_d$	Quiescent current	$V_I = 2.5\text{ to }18\text{ V}$ , $I_O = 0\text{ mA}$	ON MODE	0.5	1	mA
		$V_I = 2.5\text{ to }18\text{ V}$ , $I_O = 100\text{ mA}$		1.5	3	
		$V_I = 6\text{ V}$	OFF MODE	50	100	$\mu\text{A}$
SVR	Supply voltage rejection	$I_O = 5\text{ mA}$ , $V_I = 3.5 \pm 1\text{ V}$	$f = 120\text{ Hz}$	82		dB
			$f = 1\text{ kHz}$	77		
			$f = 10\text{ kHz}$	60		
eN	Output noise voltage	$B = 10\text{ Hz to }100\text{ kHz}$		50		$\mu\text{V}$
$V_d$	Dropout voltage	$I_O = 100\text{ mA}$ , $T_A = -40\text{ to }125\text{ }^\circ\text{C}$		1.25		V
$V_{IL}$	Control input logic low	$T_A = -40\text{ to }125\text{ }^\circ\text{C}$			0.8	V
$V_{IH}$	Control input logic high	$T_A = -40\text{ to }125\text{ }^\circ\text{C}$	2			V
$I_I$	Control input current	$V_I = 6\text{ V}$ , $V_C = 6\text{ V}$		10		$\mu\text{A}$
$C_O$	Output bypass capacitance	$\text{ESR} = 0.1\text{ to }10\text{ }\Omega$ , $I_O = 0\text{ to }100\text{ mA}$	2	10		$\mu\text{F}$



**Table 5. Electrical characteristics for LE25AB** (refer to the test circuits,  $T_J = 25\text{ }^\circ\text{C}$ ,  $C_I = 0.1\text{ }\mu\text{F}$ ,  $C_O = 2.2\text{ }\mu\text{F}$  unless otherwise specified.)

Symbol	Parameter	Test conditions	Min.	Typ.	Max.	Unit
$V_O$	Output voltage	$I_O = 10\text{ mA}$ , $V_I = 4.5\text{ V}$	2.475	2.5	2.525	V
		$I_O = 10\text{ mA}$ , $V_I = 4.5\text{ V}$ , $T_A = -25\text{ to }85\text{ }^\circ\text{C}$	2.45		2.55	
$V_I$	Operating input voltage	$I_O = 100\text{ mA}$			18	V
$I_O$	Output current limit		150			mA
$\Delta V_O$	Line regulation	$V_I = 3.2\text{ to }18\text{ V}$ , $I_O = 0.5\text{ mA}$		3	15	mV
$\Delta V_O$	Load regulation	$V_I = 3.5\text{ V}$ , $I_O = 0.5\text{ to }100\text{ mA}$		3	15	mV
$I_d$	Quiescent current	$V_I = 3.5\text{ to }18\text{ V}$ , $I_O = 0\text{ mA}$	ON MODE	0.5	1	mA
		$V_I = 3.5\text{ to }18\text{ V}$ , $I_O = 100\text{ mA}$		1.5	3	
		$V_I = 6\text{ V}$	OFF MODE	50	100	$\mu\text{A}$
SVR	Supply voltage rejection	$I_O = 5\text{ mA}$ , $V_I = 4.5 \pm 1\text{ V}$	$f = 120\text{ Hz}$	82		dB
			$f = 1\text{ kHz}$	77		
			$f = 10\text{ kHz}$	60		
eN	Output noise voltage	$B = 10\text{ Hz to }100\text{ kHz}$		50		$\mu\text{V}$
$V_d$	Dropout voltage	$I_O = 100\text{ mA}$		0.2	0.4	V
		$I_O = 100\text{ mA}$ , $T_A = -40\text{ to }125\text{ }^\circ\text{C}$			0.5	
$V_{IL}$	Control input logic low	$T_A = -40\text{ to }125\text{ }^\circ\text{C}$			0.8	V
$V_{IH}$	Control input logic high	$T_A = -40\text{ to }125\text{ }^\circ\text{C}$	2			V
$I_I$	Control input current	$V_I = 6\text{ V}$ , $V_C = 6\text{ V}$		10		$\mu\text{A}$
$C_O$	Output bypass capacitance	$\text{ESR} = 0.1\text{ to }10\text{ }\Omega$ , $I_O = 0\text{ to }100\text{ mA}$	2	10		$\mu\text{F}$

**Table 6. Electrical characteristics for LE25C** (refer to the test circuits,  $T_J = 25\text{ }^\circ\text{C}$ ,  $C_1 = 0.1\text{ }\mu\text{F}$ ,  $C_O = 2.2\text{ }\mu\text{F}$  unless otherwise specified.)

Symbol	Parameter	Test conditions	Min.	Typ.	Max.	Unit
$V_O$	Output voltage	$I_O = 10\text{ mA}$ , $V_I = 4.5\text{ V}$	2.45	2.5	2.55	V
		$I_O = 10\text{ mA}$ , $V_I = 4.5\text{ V}$ , $T_A = -25\text{ to }85\text{ }^\circ\text{C}$	2.4		2.6	
$V_I$	Operating input voltage	$I_O = 100\text{ mA}$			18	V
$I_O$	Output current limit		150			mA
$\Delta V_O$	Line regulation	$V_I = 3.2\text{ to }18\text{ V}$ , $I_O = 0.5\text{ mA}$		3	20	mV
$\Delta V_O$	Load regulation	$V_I = 3.5\text{ V}$ , $I_O = 0.5\text{ to }100\text{ mA}$		3	25	mV
$I_d$	Quiescent current	$V_I = 3.5\text{ to }18\text{ V}$ , $I_O = 0\text{ mA}$	ON MODE	0.5	1	mA
		$V_I = 3.5\text{ to }18\text{ V}$ , $I_O = 100\text{ mA}$		1.5	3	
		$V_I = 6\text{ V}$	OFF MODE	50	100	$\mu\text{A}$
SVR	Supply voltage rejection	$I_O = 5\text{ mA}$ , $V_I = 4.5 \pm 1\text{ V}$	$f = 120\text{ Hz}$	82		dB
			$f = 1\text{ kHz}$	77		
			$f = 10\text{ kHz}$	60		
eN	Output noise voltage	$B = 10\text{ Hz to }100\text{ kHz}$		50		$\mu\text{V}$
$V_d$	Dropout voltage	$I_O = 100\text{ mA}$		0.2	0.4	V
		$I_O = 100\text{ mA}$ , $T_A = -40\text{ to }125\text{ }^\circ\text{C}$			0.5	
$V_{IL}$	Control input logic low	$T_A = -40\text{ to }125\text{ }^\circ\text{C}$			0.8	V
$V_{IH}$	Control input logic high	$T_A = -40\text{ to }125\text{ }^\circ\text{C}$	2			V
$I_I$	Control input current	$V_I = 6\text{ V}$ , $V_C = 6\text{ V}$		10		$\mu\text{A}$
$C_O$	Output bypass capacitance	$\text{ESR} = 0.1\text{ to }10\text{ }\Omega$ , $I_O = 0\text{ to }100\text{ mA}$	2	10		$\mu\text{F}$

**Table 7. Electrical characteristics for LE27AB** (refer to the test circuits,  $T_J = 25\text{ }^\circ\text{C}$ ,  $C_I = 0.1\text{ }\mu\text{F}$ ,  $C_O = 2.2\text{ }\mu\text{F}$  unless otherwise specified.)

Symbol	Parameter	Test conditions	Min.	Typ.	Max.	Unit
$V_O$	Output voltage	$I_O = 10\text{ mA}$ , $V_I = 4.7\text{ V}$	2.673	2.7	2.727	V
		$I_O = 10\text{ mA}$ , $V_I = 4.7\text{ V}$ , $T_A = -25\text{ to }85\text{ }^\circ\text{C}$	2.646		2.754	
$V_I$	Operating input voltage	$I_O = 100\text{ mA}$			18	V
$I_O$	Output current limit		150			mA
$\Delta V_O$	Line regulation	$V_I = 3.4\text{ to }18\text{ V}$ , $I_O = 0.5\text{ mA}$		3	15	mV
$\Delta V_O$	Load regulation	$V_I = 3.7\text{ V}$ , $I_O = 0.5\text{ to }100\text{ mA}$		3	15	mV
$I_d$	Quiescent current	$V_I = 3.7\text{ to }18\text{ V}$ , $I_O = 0\text{ mA}$	ON MODE	0.5	1	mA
		$V_I = 3.7\text{ to }18\text{ V}$ , $I_O = 100\text{ mA}$		1.5	3	
		$V_I = 6\text{ V}$	OFF MODE	50	100	$\mu\text{A}$
SVR	Supply voltage rejection	$I_O = 5\text{ mA}$ , $V_I = 4.7 \pm 1\text{ V}$	$f = 120\text{ Hz}$	82		dB
			$f = 1\text{ kHz}$	77		
			$f = 10\text{ kHz}$	60		
eN	Output noise voltage	$B = 10\text{ Hz to }100\text{ kHz}$		50		$\mu\text{V}$
$V_d$	Dropout voltage	$I_O = 100\text{ mA}$		0.2	0.4	V
		$I_O = 100\text{ mA}$ , $T_A = -40\text{ to }125\text{ }^\circ\text{C}$			0.5	
$V_{IL}$	Control input logic low	$T_A = -40\text{ to }125\text{ }^\circ\text{C}$			0.8	V
$V_{IH}$	Control input logic high	$T_A = -40\text{ to }125\text{ }^\circ\text{C}$	2			V
$I_I$	Control input current	$V_I = 6\text{ V}$ , $V_C = 6\text{ V}$		10		$\mu\text{A}$
$C_O$	Output bypass capacitance	$\text{ESR} = 0.1\text{ to }10\text{ }\Omega$ , $I_O = 0\text{ to }100\text{ mA}$	2	10		$\mu\text{F}$

**Table 8. Electrical characteristics for LE27C** (refer to the test circuits,  $T_J = 25\text{ }^\circ\text{C}$ ,  $C_1 = 0.1\text{ }\mu\text{F}$ ,  $C_O = 2.2\text{ }\mu\text{F}$  unless otherwise specified.)

Symbol	Parameter	Test conditions	Min.	Typ.	Max.	Unit
$V_O$	Output voltage	$I_O = 10\text{ mA}$ , $V_I = 4.7\text{ V}$	2.646	2.7	2.754	V
		$I_O = 10\text{ mA}$ , $V_I = 4.7\text{ V}$ , $T_A = -25\text{ to }85\text{ }^\circ\text{C}$	2.592		2.808	
$V_I$	Operating input voltage	$I_O = 100\text{ mA}$			18	V
$I_O$	Output current limit		150			mA
$\Delta V_O$	Line regulation	$V_I = 3.4\text{ to }18\text{ V}$ , $I_O = 0.5\text{ mA}$		3	20	mV
$\Delta V_O$	Load regulation	$V_I = 3.7\text{ V}$ , $I_O = 0.5\text{ to }100\text{ mA}$		3	25	mV
$I_d$	Quiescent current	$V_I = 3.7\text{ to }18\text{ V}$ , $I_O = 0\text{ mA}$	ON MODE	0.5	1	mA
		$V_I = 3.7\text{ to }18\text{ V}$ , $I_O = 100\text{ mA}$		1.5	3	
		$V_I = 6\text{ V}$	OFF MODE	50	100	$\mu\text{A}$
SVR	Supply voltage rejection	$I_O = 5\text{ mA}$ , $V_I = 4.7 \pm 1\text{ V}$	$f = 120\text{ Hz}$	82		dB
			$f = 1\text{ kHz}$	77		
			$f = 10\text{ kHz}$	60		
eN	Output noise voltage	$B = 10\text{ Hz to }100\text{ kHz}$		50		$\mu\text{V}$
$V_d$	Dropout voltage	$I_O = 100\text{ mA}$		0.2	0.4	V
		$I_O = 100\text{ mA}$ , $T_A = -40\text{ to }125\text{ }^\circ\text{C}$			0.5	
$V_{IL}$	Control input logic low	$T_A = -40\text{ to }125\text{ }^\circ\text{C}$			0.8	V
$V_{IH}$	Control input logic high	$T_A = -40\text{ to }125\text{ }^\circ\text{C}$	2			V
$I_I$	Control input current	$V_I = 6\text{ V}$ , $V_C = 6\text{ V}$		10		$\mu\text{A}$
$C_O$	Output bypass capacitance	$\text{ESR} = 0.1\text{ to }10\text{ }\Omega$ , $I_O = 0\text{ to }100\text{ mA}$	2	10		$\mu\text{F}$

**Table 9. Electrical characteristics for LE30AB** (refer to the test circuits,  $T_J = 25\text{ °C}$ ,  $C_I = 0.1\text{ }\mu\text{F}$ ,  $C_O = 2.2\text{ }\mu\text{F}$  unless otherwise specified.)

Symbol	Parameter	Test conditions	Min.	Typ.	Max.	Unit
$V_O$	Output voltage	$I_O = 10\text{ mA}$ , $V_I = 5\text{ V}$	2.970	3	3.030	V
		$I_O = 10\text{ mA}$ , $V_I = 5\text{ V}$ , $T_A = -25\text{ to }85\text{ °C}$	2.940		3.060	
$V_I$	Operating input voltage	$I_O = 100\text{ mA}$			18	V
$I_O$	Output current limit		150			mA
$\Delta V_O$	Line regulation	$V_I = 3.7\text{ to }18\text{ V}$ , $I_O = 0.5\text{ mA}$		3	15	mV
$\Delta V_O$	Load regulation	$V_I = 4\text{ V}$ , $I_O = 0.5\text{ to }100\text{ mA}$		3	15	mV
$I_d$	Quiescent current	$V_I = 4\text{ to }18\text{ V}$ , $I_O = 0\text{ mA}$	ON MODE	0.5	1	mA
		$V_I = 4\text{ to }18\text{ V}$ , $I_O = 100\text{ mA}$		1.5	3	
		$V_I = 6\text{ V}$	OFF MODE	50	100	$\mu\text{A}$
SVR	Supply voltage rejection	$I_O = 5\text{ mA}$ , $V_I = 5 \pm 1\text{ V}$	$f = 120\text{ Hz}$	81		dB
			$f = 1\text{ kHz}$	76		
			$f = 10\text{ kHz}$	60		
eN	Output noise voltage	$B = 10\text{ Hz to }100\text{ kHz}$		50		$\mu\text{V}$
$V_d$	Dropout voltage	$I_O = 100\text{ mA}$		0.2	0.4	V
		$I_O = 100\text{ mA}$ , $T_A = -40\text{ to }125\text{ °C}$			0.5	
$V_{IL}$	Control input logic low	$T_A = -40\text{ to }125\text{ °C}$			0.8	V
$V_{IH}$	Control input logic high	$T_A = -40\text{ to }125\text{ °C}$	2			V
$I_I$	Control input current	$V_I = 6\text{ V}$ , $V_C = 6\text{ V}$		10		$\mu\text{A}$
$C_O$	Output bypass capacitance	$\text{ESR} = 0.1\text{ to }10\text{ }\Omega$ , $I_O = 0\text{ to }100\text{ mA}$	2	10		$\mu\text{F}$

**Table 10. Electrical characteristics for LE30C** (refer to the test circuits,  $T_J = 25\text{ }^\circ\text{C}$ ,  $C_1 = 0.1\text{ }\mu\text{F}$ ,  $C_O = 2.2\text{ }\mu\text{F}$  unless otherwise specified.)

Symbol	Parameter	Test conditions	Min.	Typ.	Max.	Unit	
$V_O$	Output voltage	$I_O = 10\text{ mA}$ , $V_I = 5\text{ V}$	2.940	3	3.060	V	
		$I_O = 10\text{ mA}$ , $V_I = 5\text{ V}$ , $T_A = -25\text{ to }85\text{ }^\circ\text{C}$	2.880		3.120		
$V_I$	Operating input voltage	$I_O = 100\text{ mA}$			18	V	
$I_O$	Output current limit		150			mA	
$\Delta V_O$	Line regulation	$V_I = 3.7\text{ to }18\text{ V}$ , $I_O = 0.5\text{ mA}$		3	20	mV	
$\Delta V_O$	Load regulation	$V_I = 4\text{ V}$ , $I_O = 0.5\text{ to }100\text{ mA}$		3	25	mV	
$I_d$	Quiescent current	$V_I = 4\text{ to }18\text{ V}$ , $I_O = 0\text{ mA}$	ON MODE		0.5	1	mA
		$V_I = 4\text{ to }18\text{ V}$ , $I_O = 100\text{ mA}$			1.5	3	
		$V_I = 6\text{ V}$	OFF MODE		50	100	$\mu\text{A}$
SVR	Supply voltage rejection	$I_O = 5\text{ mA}$ , $V_I = 5 \pm 1\text{ V}$	$f = 120\text{ Hz}$		81		dB
			$f = 1\text{ kHz}$		76		
			$f = 10\text{ kHz}$		60		
eN	Output noise voltage	$B = 10\text{ Hz to }100\text{ kHz}$		50		$\mu\text{V}$	
$V_d$	Dropout voltage	$I_O = 100\text{ mA}$		0.2	0.4	V	
		$I_O = 100\text{ mA}$ , $T_A = -40\text{ to }125\text{ }^\circ\text{C}$			0.5		
$V_{IL}$	Control input logic low	$T_A = -40\text{ to }125\text{ }^\circ\text{C}$			0.8	V	
$V_{IH}$	Control input logic high	$T_A = -40\text{ to }125\text{ }^\circ\text{C}$	2			V	
$I_I$	Control input current	$V_I = 6\text{ V}$ , $V_C = 6\text{ V}$		10		$\mu\text{A}$	
$C_O$	Output bypass capacitance	$\text{ESR} = 0.1\text{ to }10\text{ }\Omega$ , $I_O = 0\text{ to }100\text{ mA}$	2	10		$\mu\text{F}$	

**Table 11. Electrical characteristics for LE33AB** (refer to the test circuits,  $T_J = 25\text{ °C}$ ,  $C_I = 0.1\text{ }\mu\text{F}$ ,  $C_O = 2.2\text{ }\mu\text{F}$  unless otherwise specified.)

Symbol	Parameter	Test conditions	Min.	Typ.	Max.	Unit
$V_O$	Output voltage	$I_O = 10\text{ mA}$ , $V_I = 5.3\text{ V}$	3.267	3.3	3.333	V
		$I_O = 10\text{ mA}$ , $V_I = 5.3\text{ V}$ , $T_A = -25\text{ to }85\text{ °C}$	3.234		3.366	
$V_I$	Operating input voltage	$I_O = 100\text{ mA}$			18	V
$I_O$	Output current limit		150			mA
$\Delta V_O$	Line regulation	$V_I = 4\text{ to }18\text{ V}$ , $I_O = 0.5\text{ mA}$		3	15	mV
$\Delta V_O$	Load regulation	$V_I = 4.3\text{ V}$ , $I_O = 0.5\text{ to }100\text{ mA}$		3	15	mV
$I_d$	Quiescent current	$V_I = 4.3\text{ to }18\text{ V}$ , $I_O = 0\text{ mA}$	ON MODE	0.5	1	mA
		$V_I = 4.3\text{ to }18\text{ V}$ , $I_O = 100\text{ mA}$		1.5	3	
		$V_I = 6\text{ V}$	OFF MODE	50	100	$\mu\text{A}$
SVR	Supply voltage rejection	$I_O = 5\text{ mA}$ , $V_I = 5.3 \pm 1\text{ V}$	$f = 120\text{ Hz}$	80		dB
			$f = 1\text{ kHz}$	75		
			$f = 10\text{ kHz}$	60		
eN	Output noise voltage	$B = 10\text{ Hz to }100\text{ kHz}$		50		$\mu\text{V}$
$V_d$	Dropout voltage	$I_O = 100\text{ mA}$		0.2	0.4	V
		$I_O = 100\text{ mA}$ , $T_A = -40\text{ to }125\text{ °C}$			0.5	
$V_{IL}$	Control input logic low	$T_A = -40\text{ to }125\text{ °C}$			0.8	V
$V_{IH}$	Control input logic high	$T_A = -40\text{ to }125\text{ °C}$	2			V
$I_I$	Control input current	$V_I = 6\text{ V}$ , $V_C = 6\text{ V}$		10		$\mu\text{A}$
$C_O$	Output bypass capacitance	$\text{ESR} = 0.1\text{ to }10\text{ }\Omega$ , $I_O = 0\text{ to }100\text{ mA}$	2	10		$\mu\text{F}$

**Table 12. Electrical characteristics for LE33C** (refer to the test circuits,  $T_J = 25\text{ °C}$ ,  $C_1 = 0.1\text{ }\mu\text{F}$ ,  $C_O = 2.2\text{ }\mu\text{F}$  unless otherwise specified.)

Symbol	Parameter	Test conditions	Min.	Typ.	Max.	Unit
$V_O$	Output voltage	$I_O = 10\text{ mA}$ , $V_I = 5.3\text{ V}$	3.234	3.3	3.366	V
		$I_O = 10\text{ mA}$ , $V_I = 5.3\text{ V}$ , $T_A = -25\text{ to }85\text{ °C}$	3.168		3.432	
$V_I$	Operating input voltage	$I_O = 100\text{ mA}$			18	V
$I_O$	Output current limit		150			mA
$\Delta V_O$	Line regulation	$V_I = 4\text{ to }18\text{ V}$ , $I_O = 0.5\text{ mA}$		3	20	mV
$\Delta V_O$	Load regulation	$V_I = 4.3\text{ V}$ , $I_O = 0.5\text{ to }100\text{ mA}$		3	25	mV
$I_d$	Quiescent current	$V_I = 4.3\text{ to }18\text{ V}$ , $I_O = 0\text{ mA}$	ON MODE	0.5	1	mA
		$V_I = 4.3\text{ to }18\text{ V}$ , $I_O = 100\text{ mA}$		1.5	3	
		$V_I = 6\text{ V}$	OFF MODE	50	100	$\mu\text{A}$
SVR	Supply voltage rejection	$I_O = 5\text{ mA}$ , $V_I = 5.3 \pm 1\text{ V}$	$f = 120\text{ Hz}$	80		dB
			$f = 1\text{ kHz}$	75		
			$f = 10\text{ kHz}$	60		
eN	Output noise voltage	$B = 10\text{ Hz to }100\text{ kHz}$		50		$\mu\text{V}$
$V_d$	Dropout voltage	$I_O = 100\text{ mA}$		0.2	0.4	V
		$I_O = 100\text{ mA}$ , $T_A = -40\text{ to }125\text{ °C}$			0.5	
$V_{IL}$	Control input logic low	$T_A = -40\text{ to }125\text{ °C}$			0.8	V
$V_{IH}$	Control input logic high	$T_A = -40\text{ to }125\text{ °C}$	2			V
$I_I$	Control input current	$V_I = 6\text{ V}$ , $V_C = 6\text{ V}$		10		$\mu\text{A}$
$C_O$	Output bypass capacitance	$\text{ESR} = 0.1\text{ to }10\text{ }\Omega$ , $I_O = 0\text{ to }100\text{ mA}$	2	10		$\mu\text{F}$



**Table 13. Electrical characteristics for LE35AB** (refer to the test circuits,  $T_J = 25\text{ }^\circ\text{C}$ ,  $C_I = 0.1\text{ }\mu\text{F}$ ,  $C_O = 2.2\text{ }\mu\text{F}$  unless otherwise specified.)

Symbol	Parameter	Test conditions	Min.	Typ.	Max.	Unit
$V_O$	Output voltage	$I_O = 10\text{ mA}$ , $V_I = 5.5\text{ V}$	3.465	3.5	3.535	V
		$I_O = 10\text{ mA}$ , $V_I = 5.5\text{ V}$ , $T_A = -25\text{ to }85\text{ }^\circ\text{C}$	3.43		3.57	
$V_I$	Operating input voltage	$I_O = 100\text{ mA}$			18	V
$I_O$	Output current limit		150			mA
$\Delta V_O$	Line regulation	$V_I = 4.2\text{ to }18\text{ V}$ , $I_O = 0.5\text{ mA}$		3	15	mV
$\Delta V_O$	Load regulation	$V_I = 4.5\text{ V}$ , $I_O = 0.5\text{ to }100\text{ mA}$		3	15	mV
$I_d$	Quiescent current	$V_I = 4.5\text{ to }18\text{ V}$ , $I_O = 0\text{ mA}$	ON MODE	0.5	1	mA
		$V_I = 4.5\text{ to }18\text{ V}$ , $I_O = 100\text{ mA}$		1.5	3	
		$V_I = 6\text{ V}$	OFF MODE	50	100	$\mu\text{A}$
SVR	Supply voltage rejection	$I_O = 5\text{ mA}$ , $V_I = 5.5 \pm 1\text{ V}$	$f = 120\text{ Hz}$	79		dB
			$f = 1\text{ kHz}$	74		
			$f = 10\text{ kHz}$	60		
eN	Output noise voltage	$B = 10\text{ Hz to }100\text{ kHz}$		50		$\mu\text{V}$
$V_d$	Dropout voltage	$I_O = 100\text{ mA}$		0.2	0.4	V
		$I_O = 100\text{ mA}$ , $T_A = -40\text{ to }125\text{ }^\circ\text{C}$			0.5	
$V_{IL}$	Control input logic low	$T_A = -40\text{ to }125\text{ }^\circ\text{C}$			0.8	V
$V_{IH}$	Control input logic high	$T_A = -40\text{ to }125\text{ }^\circ\text{C}$	2			V
$I_I$	Control input current	$V_I = 6\text{ V}$ , $V_C = 6\text{ V}$		10		$\mu\text{A}$
$C_O$	Output bypass capacitance	$\text{ESR} = 0.1\text{ to }10\text{ }\Omega$ , $I_O = 0\text{ to }100\text{ mA}$	2	10		$\mu\text{F}$

**Table 14. Electrical characteristics for LE35C** (refer to the test circuits,  $T_J = 25\text{ }^\circ\text{C}$ ,  $C_1 = 0.1\text{ }\mu\text{F}$ ,  $C_O = 2.2\text{ }\mu\text{F}$  unless otherwise specified.)

Symbol	Parameter	Test conditions	Min.	Typ.	Max.	Unit
$V_O$	Output voltage	$I_O = 10\text{ mA}$ , $V_I = 5.5\text{ V}$	3.43	3.5	3.57	V
		$I_O = 10\text{ mA}$ , $V_I = 5.5\text{ V}$ , $T_A = -25\text{ to }85\text{ }^\circ\text{C}$	3.36		3.64	
$V_I$	Operating input voltage	$I_O = 100\text{ mA}$			18	V
$I_O$	Output current limit		150			mA
$\Delta V_O$	Line regulation	$V_I = 4.2\text{ to }18\text{ V}$ , $I_O = 0.5\text{ mA}$		3	20	mV
$\Delta V_O$	Load regulation	$V_I = 4.5\text{ V}$ , $I_O = 0.5\text{ to }100\text{ mA}$		3	25	mV
$I_d$	Quiescent current	$V_I = 4.5\text{ to }18\text{ V}$ , $I_O = 0\text{ mA}$	ON MODE	0.5	1	mA
		$V_I = 4.5\text{ to }18\text{ V}$ , $I_O = 100\text{ mA}$		1.5	3	
		$V_I = 6\text{ V}$	OFF MODE	50	100	$\mu\text{A}$
SVR	Supply voltage rejection	$I_O = 5\text{ mA}$ , $V_I = 5.5 \pm 1\text{ V}$	$f = 120\text{ Hz}$	79		dB
			$f = 1\text{ kHz}$	74		
			$f = 10\text{ kHz}$	60		
eN	Output noise voltage	$B = 10\text{ Hz to }100\text{ kHz}$		50		$\mu\text{V}$
$V_d$	Dropout voltage	$I_O = 100\text{ mA}$		0.2	0.4	V
		$I_O = 100\text{ mA}$ , $T_A = -40\text{ to }125\text{ }^\circ\text{C}$			0.5	
$V_{IL}$	Control input logic low	$T_A = -40\text{ to }125\text{ }^\circ\text{C}$			0.8	V
$V_{IH}$	Control input logic high	$T_A = -40\text{ to }125\text{ }^\circ\text{C}$	2			V
$I_I$	Control input current	$V_I = 6\text{ V}$ , $V_C = 6\text{ V}$		10		$\mu\text{A}$
$C_O$	Output bypass capacitance	$\text{ESR} = 0.1\text{ to }10\text{ }\Omega$ , $I_O = 0\text{ to }100\text{ mA}$	2	10		$\mu\text{F}$

**Table 15. Electrical characteristics for LE40AB** (refer to the test circuits,  $T_J = 25\text{ °C}$ ,  $C_I = 0.1\text{ }\mu\text{F}$ ,  $C_O = 2.2\text{ }\mu\text{F}$  unless otherwise specified.)

Symbol	Parameter	Test conditions	Min.	Typ.	Max.	Unit
$V_O$	Output voltage	$I_O = 10\text{ mA}$ , $V_I = 6\text{ V}$	3.96	4	4.04	V
		$I_O = 10\text{ mA}$ , $V_I = 6\text{ V}$ , $T_A = -25\text{ to }85\text{ °C}$	3.92		4.08	
$V_I$	Operating input voltage	$I_O = 100\text{ mA}$			18	V
$I_O$	Output current limit		150			mA
$\Delta V_O$	Line regulation	$V_I = 4.7\text{ to }18\text{ V}$ , $I_O = 0.5\text{ mA}$		4	20	mV
$\Delta V_O$	Load regulation	$V_I = 5\text{ V}$ , $I_O = 0.5\text{ to }100\text{ mA}$		3	15	mV
$I_d$	Quiescent current	$V_I = 5\text{ to }18\text{ V}$ , $I_O = 0\text{ mA}$	ON MODE	0.5	1	mA
		$V_I = 5\text{ to }18\text{ V}$ , $I_O = 100\text{ mA}$		1.5	3	
		$V_I = 6\text{ V}$	OFF MODE	50	100	$\mu\text{A}$
SVR	Supply voltage rejection	$I_O = 5\text{ mA}$ , $V_I = 6 \pm 1\text{ V}$	$f = 120\text{ Hz}$	78		dB
			$f = 1\text{ kHz}$	73		
			$f = 10\text{ kHz}$	60		
eN	Output noise voltage	$B = 10\text{ Hz to }100\text{ kHz}$		50		$\mu\text{V}$
$V_d$	Dropout voltage	$I_O = 100\text{ mA}$		0.2	0.4	V
		$I_O = 100\text{ mA}$ , $T_A = -40\text{ to }125\text{ °C}$			0.5	
$V_{IL}$	Control input logic low	$T_A = -40\text{ to }125\text{ °C}$			0.8	V
$V_{IH}$	Control input logic high	$T_A = -40\text{ to }125\text{ °C}$	2			V
$I_I$	Control input current	$V_I = 6\text{ V}$ , $V_C = 6\text{ V}$		10		$\mu\text{A}$
$C_O$	Output bypass capacitance	$\text{ESR} = 0.1\text{ to }10\text{ }\Omega$ , $I_O = 0\text{ to }100\text{ mA}$	2	10		$\mu\text{F}$

**Table 16. Electrical characteristics for LE40C** (refer to the test circuits,  $T_J = 25\text{ }^\circ\text{C}$ ,  $C_1 = 0.1\text{ }\mu\text{F}$ ,  $C_O = 2.2\text{ }\mu\text{F}$  unless otherwise specified.)

Symbol	Parameter	Test conditions	Min.	Typ.	Max.	Unit	
$V_O$	Output voltage	$I_O = 10\text{ mA}$ , $V_I = 6\text{ V}$	3.92	4	4.08	V	
		$I_O = 10\text{ mA}$ , $V_I = 6\text{ V}$ , $T_A = -25\text{ to }85\text{ }^\circ\text{C}$	3.84		4.16		
$V_I$	Operating input voltage	$I_O = 100\text{ mA}$			18	V	
$I_O$	Output current limit		150			mA	
$\Delta V_O$	Line regulation	$V_I = 4.7\text{ to }18\text{ V}$ , $I_O = 0.5\text{ mA}$		4	30	mV	
$\Delta V_O$	Load regulation	$V_I = 5\text{ V}$ , $I_O = 0.5\text{ to }100\text{ mA}$		3	25	mV	
$I_d$	Quiescent current	$V_I = 5\text{ to }18\text{ V}$ , $I_O = 0\text{ mA}$	ON MODE		0.5	1	mA
		$V_I = 5\text{ to }18\text{ V}$ , $I_O = 100\text{ mA}$			1.5	3	
		$V_I = 6\text{ V}$	OFF MODE		50	100	$\mu\text{A}$
SVR	Supply voltage rejection	$I_O = 5\text{ mA}$ , $V_I = 6 \pm 1\text{ V}$	$f = 120\text{ Hz}$		78		dB
			$f = 1\text{ kHz}$		73		
			$f = 10\text{ kHz}$		60		
eN	Output noise voltage	$B = 10\text{ Hz to }100\text{ kHz}$		50		$\mu\text{V}$	
$V_d$	Dropout voltage	$I_O = 100\text{ mA}$		0.2	0.4	V	
		$I_O = 100\text{ mA}$ , $T_A = -40\text{ to }125\text{ }^\circ\text{C}$			0.5		
$V_{IL}$	Control input logic low	$T_A = -40\text{ to }125\text{ }^\circ\text{C}$			0.8	V	
$V_{IH}$	Control input logic high	$T_A = -40\text{ to }125\text{ }^\circ\text{C}$	2			V	
$I_I$	Control input current	$V_I = 6\text{ V}$ , $V_C = 6\text{ V}$		10		$\mu\text{A}$	
$C_O$	Output bypass capacitance	$\text{ESR} = 0.1\text{ to }10\text{ }\Omega$ , $I_O = 0\text{ to }100\text{ mA}$	2	10		$\mu\text{F}$	

**Table 17. Electrical characteristics for LE45AB** (refer to the test circuits,  $T_J = 25\text{ }^\circ\text{C}$ ,  $C_I = 0.1\text{ }\mu\text{F}$ ,  $C_O = 2.2\text{ }\mu\text{F}$  unless otherwise specified.)

Symbol	Parameter	Test conditions	Min.	Typ.	Max.	Unit
$V_O$	Output voltage	$I_O = 10\text{ mA}$ , $V_I = 6.5\text{ V}$	4.445	4.5	4.545	V
		$I_O = 10\text{ mA}$ , $V_I = 6.5\text{ V}$ , $T_A = -25\text{ to }85\text{ }^\circ\text{C}$	4.41		4.59	
$V_I$	Operating input voltage	$I_O = 100\text{ mA}$			18	V
$I_O$	Output current limit		150			mA
$\Delta V_O$	Line regulation	$V_I = 5.2\text{ to }18\text{ V}$ , $I_O = 0.5\text{ mA}$		4	20	mV
$\Delta V_O$	Load regulation	$V_I = 5.5\text{ V}$ , $I_O = 0.5\text{ to }100\text{ mA}$		3	15	mV
$I_d$	Quiescent current	$V_I = 5.5\text{ to }18\text{ V}$ , $I_O = 0\text{ mA}$	ON MODE	0.5	1	mA
		$V_I = 5.5\text{ to }18\text{ V}$ , $I_O = 100\text{ mA}$		1.5	3	
		$V_I = 6\text{ V}$	OFF MODE	50	100	$\mu\text{A}$
SVR	Supply voltage rejection	$I_O = 5\text{ mA}$ , $V_I = 6.5 \pm 1\text{ V}$	$f = 120\text{ Hz}$	77		dB
			$f = 1\text{ kHz}$	72		
			$f = 10\text{ kHz}$	60		
eN	Output noise voltage	$B = 10\text{ Hz to }100\text{ kHz}$		50		$\mu\text{V}$
$V_d$	Dropout voltage	$I_O = 100\text{ mA}$		0.2	0.4	V
		$I_O = 100\text{ mA}$ , $T_A = -40\text{ to }125\text{ }^\circ\text{C}$			0.5	
$V_{IL}$	Control input logic low	$T_A = -40\text{ to }125\text{ }^\circ\text{C}$			0.8	V
$V_{IH}$	Control input logic high	$T_A = -40\text{ to }125\text{ }^\circ\text{C}$	2			V
$I_I$	Control input current	$V_I = 6\text{ V}$ , $V_C = 6\text{ V}$		10		$\mu\text{A}$
$C_O$	Output bypass capacitance	$\text{ESR} = 0.1\text{ to }10\text{ }\Omega$ , $I_O = 0\text{ to }100\text{ mA}$	2	10		$\mu\text{F}$

**Table 18. Electrical characteristics for LE45C** (refer to the test circuits,  $T_J = 25\text{ }^\circ\text{C}$ ,  $C_1 = 0.1\text{ }\mu\text{F}$ ,  $C_O = 2.2\text{ }\mu\text{F}$  unless otherwise specified.)

Symbol	Parameter	Test conditions	Min.	Typ.	Max.	Unit
$V_O$	Output voltage	$I_O = 10\text{ mA}$ , $V_I = 6.5\text{ V}$	4.41	4.5	4.59	V
		$I_O = 10\text{ mA}$ , $V_I = 6.5\text{ V}$ , $T_A = -25\text{ to }85\text{ }^\circ\text{C}$	4.32		4.68	
$V_I$	Operating input voltage	$I_O = 100\text{ mA}$			18	V
$I_O$	Output current limit		150			mA
$\Delta V_O$	Line regulation	$V_I = 5.2\text{ to }18\text{ V}$ , $I_O = 0.5\text{ mA}$		4	30	mV
$\Delta V_O$	Load regulation	$V_I = 5.5\text{ V}$ , $I_O = 0.5\text{ to }100\text{ mA}$		3	25	mV
$I_d$	Quiescent current	$V_I = 5.5\text{ to }18\text{ V}$ , $I_O = 0\text{ mA}$	ON MODE	0.5	1	mA
		$V_I = 5.5\text{ to }18\text{ V}$ , $I_O = 100\text{ mA}$		1.5	3	
		$V_I = 6\text{ V}$	OFF MODE	50	100	$\mu\text{A}$
SVR	Supply voltage rejection	$I_O = 5\text{ mA}$ , $V_I = 6.5 \pm 1\text{ V}$	$f = 120\text{ Hz}$	77		dB
			$f = 1\text{ kHz}$	72		
			$f = 10\text{ kHz}$	60		
eN	Output noise voltage	$B = 10\text{ Hz to }100\text{ kHz}$		50		$\mu\text{V}$
$V_d$	Dropout voltage	$I_O = 100\text{ mA}$		0.2	0.4	V
		$I_O = 100\text{ mA}$ , $T_A = -40\text{ to }125\text{ }^\circ\text{C}$			0.5	
$V_{IL}$	Control input logic low	$T_A = -40\text{ to }125\text{ }^\circ\text{C}$			0.8	V
$V_{IH}$	Control input logic high	$T_A = -40\text{ to }125\text{ }^\circ\text{C}$	2			V
$I_I$	Control input current	$V_I = 6\text{ V}$ , $V_C = 6\text{ V}$		10		$\mu\text{A}$
$C_O$	Output bypass capacitance	$\text{ESR} = 0.1\text{ to }10\text{ }\Omega$ , $I_O = 0\text{ to }100\text{ mA}$	2	10		$\mu\text{F}$

**Table 19. Electrical characteristics for LE47AB** (refer to the test circuits,  $T_J = 25\text{ }^\circ\text{C}$ ,  $C_I = 0.1\text{ }\mu\text{F}$ ,  $C_O = 2.2\text{ }\mu\text{F}$  unless otherwise specified.)

Symbol	Parameter	Test conditions	Min.	Typ.	Max.	Unit
$V_O$	Output voltage	$I_O = 10\text{ mA}$ , $V_I = 6.7\text{ V}$	4.653	4.7	4.747	V
		$I_O = 10\text{ mA}$ , $V_I = 6.7\text{ V}$ , $T_A = -25\text{ to }85\text{ }^\circ\text{C}$	4.606		4.794	
$V_I$	Operating input voltage	$I_O = 100\text{ mA}$			18	V
$I_O$	Output current limit		150			mA
$\Delta V_O$	Line regulation	$V_I = 5.4\text{ to }18\text{ V}$ , $I_O = 0.5\text{ mA}$		4	20	mV
$\Delta V_O$	Load regulation	$V_I = 5.7\text{ V}$ , $I_O = 0.5\text{ to }100\text{ mA}$		3	15	mV
$I_d$	Quiescent current	$V_I = 5.7\text{ to }18\text{ V}$ , $I_O = 0\text{ mA}$	ON MODE	0.5	1	mA
		$V_I = 5.7\text{ to }18\text{ V}$ , $I_O = 100\text{ mA}$		1.5	3	
		$V_I = 6\text{ V}$	OFF MODE	50	100	$\mu\text{A}$
SVR	Supply voltage rejection	$I_O = 5\text{ mA}$ , $V_I = 6.7 \pm 1\text{ V}$	$f = 120\text{ Hz}$	77		dB
			$f = 1\text{ kHz}$	72		
			$f = 10\text{ kHz}$	60		
eN	Output noise voltage	$B = 10\text{ Hz to }100\text{ kHz}$		50		$\mu\text{V}$
$V_d$	Dropout voltage	$I_O = 100\text{ mA}$		0.2	0.4	V
		$I_O = 100\text{ mA}$ , $T_A = -40\text{ to }125\text{ }^\circ\text{C}$			0.5	
$V_{IL}$	Control input logic low	$T_A = -40\text{ to }125\text{ }^\circ\text{C}$			0.8	V
$V_{IH}$	Control input logic high	$T_A = -40\text{ to }125\text{ }^\circ\text{C}$	2			V
$I_I$	Control input current	$V_I = 6\text{ V}$ , $V_C = 6\text{ V}$		10		$\mu\text{A}$
$C_O$	Output bypass capacitance	$\text{ESR} = 0.1\text{ to }10\text{ }\Omega$ , $I_O = 0\text{ to }100\text{ mA}$	2	10		$\mu\text{F}$

**Table 20. Electrical characteristics for LE47C** (refer to the test circuits,  $T_J = 25\text{ °C}$ ,  $C_1 = 0.1\text{ }\mu\text{F}$ ,  $C_O = 2.2\text{ }\mu\text{F}$  unless otherwise specified.)

Symbol	Parameter	Test conditions	Min.	Typ.	Max.	Unit
$V_O$	Output voltage	$I_O = 10\text{ mA}$ , $V_I = 6.7\text{ V}$	4.606	4.7	4.794	V
		$I_O = 10\text{ mA}$ , $V_I = 6.7\text{ V}$ , $T_A = -25\text{ to }85\text{ °C}$	4.512		4.888	
$V_I$	Operating input voltage	$I_O = 100\text{ mA}$			18	V
$I_O$	Output current limit		150			mA
$\Delta V_O$	Line regulation	$V_I = 5.4\text{ to }18\text{ V}$ , $I_O = 0.5\text{ mA}$		4	30	mV
$\Delta V_O$	Load regulation	$V_I = 5.7\text{ V}$ , $I_O = 0.5\text{ to }100\text{ mA}$		3	25	mV
$I_d$	Quiescent current	$V_I = 5.7\text{ to }18\text{ V}$ , $I_O = 0\text{ mA}$	ON MODE	0.5	1	mA
		$V_I = 5.7\text{ to }18\text{ V}$ , $I_O = 100\text{ mA}$		1.5	3	
		$V_I = 6\text{ V}$	OFF MODE	50	100	$\mu\text{A}$
SVR	Supply voltage rejection	$I_O = 5\text{ mA}$ , $V_I = 6.7 \pm 1\text{ V}$	$f = 120\text{ Hz}$	77		dB
			$f = 1\text{ kHz}$	72		
			$f = 10\text{ kHz}$	60		
eN	Output noise voltage	$B = 10\text{ Hz to }100\text{ kHz}$		50		$\mu\text{V}$
$V_d$	Dropout voltage	$I_O = 100\text{ mA}$		0.2	0.4	V
		$I_O = 100\text{ mA}$ , $T_A = -40\text{ to }125\text{ °C}$			0.5	
$V_{IL}$	Control input logic low	$T_A = -40\text{ to }125\text{ °C}$			0.8	V
$V_{IH}$	Control input logic high	$T_A = -40\text{ to }125\text{ °C}$	2			V
$I_I$	Control input current	$V_I = 6\text{ V}$ , $V_C = 6\text{ V}$		10		$\mu\text{A}$
$C_O$	Output bypass capacitance	$\text{ESR} = 0.1\text{ to }10\text{ }\Omega$ , $I_O = 0\text{ to }100\text{ mA}$	2	10		$\mu\text{F}$



**Table 21. Electrical characteristics for LE50AB** (refer to the test circuits,  $T_J = 25\text{ °C}$ ,  $C_I = 0.1\text{ }\mu\text{F}$ ,  $C_O = 2.2\text{ }\mu\text{F}$  unless otherwise specified.)

Symbol	Parameter	Test conditions	Min.	Typ.	Max.	Unit	
$V_O$	Output voltage	$I_O = 10\text{ mA}$ , $V_I = 7\text{ V}$	4.95	5	5.05	V	
		$I_O = 10\text{ mA}$ , $V_I = 7\text{ V}$ , $T_A = -25\text{ to }85\text{ °C}$	4.9		5.1		
$V_I$	Operating input voltage	$I_O = 100\text{ mA}$			18	V	
$I_O$	Output current limit		150	350	425	mA	
$\Delta V_O$	Line regulation	$V_I = 5.7\text{ to }18\text{ V}$ , $I_O = 0.5\text{ mA}$		4	20	mV	
$\Delta V_O$	Load regulation	$V_I = 6\text{ V}$ , $I_O = 0.5\text{ to }100\text{ mA}$		3	15	mV	
$I_d$	Quiescent current	$V_I = 6\text{ to }18\text{ V}$ , $I_O = 0\text{ mA}$	ON MODE		0.5	1	mA
		$V_I = 6\text{ to }18\text{ V}$ , $I_O = 100\text{ mA}$			1.5	3	
		$V_I = 6\text{ V}$	OFF MODE		50	100	$\mu\text{A}$
SVR	Supply voltage rejection	$I_O = 5\text{ mA}$ , $V_I = 7 \pm 1\text{ V}$	$f = 120\text{ Hz}$		76		dB
			$f = 1\text{ kHz}$		71		
			$f = 10\text{ kHz}$		60		
eN	Output noise voltage	$B = 10\text{ Hz to }100\text{ kHz}$		50		$\mu\text{V}$	
$V_d$	Dropout voltage	$I_O = 100\text{ mA}$		0.2	0.4	V	
		$I_O = 100\text{ mA}$ , $T_A = -40\text{ to }125\text{ °C}$			0.5		
$V_{IL}$	Control input logic low	$T_A = -40\text{ to }125\text{ °C}$			0.8	V	
$V_{IH}$	Control input logic high	$T_A = -40\text{ to }125\text{ °C}$	2			V	
$I_I$	Control input current	$V_I = 6\text{ V}$ , $V_C = 6\text{ V}$		10		$\mu\text{A}$	
$C_O$	Output bypass capacitance	$\text{ESR} = 0.1\text{ to }10\text{ }\Omega$ , $I_O = 0\text{ to }100\text{ mA}$	2	10		$\mu\text{F}$	

**Table 22. Electrical characteristics for LE50C** (refer to the test circuits,  $T_J = 25\text{ }^\circ\text{C}$ ,  $C_1 = 0.1\text{ }\mu\text{F}$ ,  $C_O = 2.2\text{ }\mu\text{F}$  unless otherwise specified.)

Symbol	Parameter	Test conditions	Min.	Typ.	Max.	Unit	
$V_O$	Output voltage	$I_O = 10\text{ mA}$ , $V_I = 7\text{ V}$	4.9	5	5.1	V	
		$I_O = 10\text{ mA}$ , $V_I = 7\text{ V}$ , $T_A = -25\text{ to }85\text{ }^\circ\text{C}$	4.8		5.2		
$V_I$	Operating input voltage	$I_O = 100\text{ mA}$			18	V	
$I_O$	Output current limit		150	350	425	mA	
$\Delta V_O$	Line regulation	$V_I = 5.7\text{ to }18\text{ V}$ , $I_O = 0.5\text{ mA}$		4	30	mV	
$\Delta V_O$	Load regulation	$V_I = 6\text{ V}$ , $I_O = 0.5\text{ to }100\text{ mA}$		3	25	mV	
$I_d$	Quiescent current	$V_I = 6\text{ to }18\text{ V}$ , $I_O = 0\text{ mA}$	ON MODE		0.5	1	mA
		$V_I = 6\text{ to }18\text{ V}$ , $I_O = 100\text{ mA}$			1.5	3	
		$V_I = 6\text{ V}$	OFF MODE		50	100	$\mu\text{A}$
SVR	Supply voltage rejection	$I_O = 5\text{ mA}$ , $V_I = 7 \pm 1\text{ V}$	$f = 120\text{ Hz}$		76		dB
			$f = 1\text{ kHz}$		71		
			$f = 10\text{ kHz}$		60		
eN	Output noise voltage	$B = 10\text{ Hz to }100\text{ kHz}$		50		$\mu\text{V}$	
$V_d$	Dropout voltage	$I_O = 100\text{ mA}$		0.2	0.4	V	
		$I_O = 100\text{ mA}$ , $T_A = -40\text{ to }125\text{ }^\circ\text{C}$			0.5		
$V_{IL}$	Control input logic low	$T_A = -40\text{ to }125\text{ }^\circ\text{C}$			0.8	V	
$V_{IH}$	Control input logic high	$T_A = -40\text{ to }125\text{ }^\circ\text{C}$	2			V	
$I_I$	Control input current	$V_I = 6\text{ V}$ , $V_C = 6\text{ V}$		10		$\mu\text{A}$	
$C_O$	Output bypass capacitance	$\text{ESR} = 0.1\text{ to }10\text{ }\Omega$ , $I_O = 0\text{ to }100\text{ mA}$	2	10		$\mu\text{F}$	

**Table 23. Electrical characteristics for LE80AB** (refer to the test circuits,  $T_J = 25\text{ °C}$ ,  $C_I = 0.1\text{ }\mu\text{F}$ ,  $C_O = 2.2\text{ }\mu\text{F}$  unless otherwise specified.)

Symbol	Parameter	Test conditions	Min.	Typ.	Max.	Unit	
$V_O$	Output voltage	$I_O = 10\text{ mA}$ , $V_I = 10\text{ V}$	7.92	8	8.08	V	
		$I_O = 10\text{ mA}$ , $V_I = 10\text{ V}$ , $T_A = -25\text{ to }85\text{ °C}$	7.84		8.16		
$V_I$	Operating input voltage	$I_O = 100\text{ mA}$			18	V	
$I_O$	Output current limit		150			mA	
$\Delta V_O$	Line regulation	$V_I = 8.7\text{ to }18\text{ V}$ , $I_O = 0.5\text{ mA}$		5	25	mV	
$\Delta V_O$	Load regulation	$V_I = 9\text{ V}$ , $I_O = 0.5\text{ to }100\text{ mA}$		3	15	mV	
$I_d$	Quiescent current	$V_I = 9\text{ to }18\text{ V}$ , $I_O = 0\text{ mA}$	ON MODE		0.7	1.6	mA
		$V_I = 9\text{ to }18\text{ V}$ , $I_O = 100\text{ mA}$			1.7	3.6	
		$V_I = 9\text{ V}$	OFF MODE		70	140	$\mu\text{A}$
SVR	Supply voltage rejection	$I_O = 5\text{ mA}$ , $V_I = 10 \pm 1\text{ V}$	$f = 120\text{ Hz}$		72		dB
			$f = 1\text{ kHz}$		66		
			$f = 10\text{ kHz}$		57		
eN	Output noise voltage	$B = 10\text{ Hz to }100\text{ kHz}$		50		$\mu\text{V}$	
$V_d$	Dropout voltage	$I_O = 100\text{ mA}$		0.2	0.4	V	
		$I_O = 100\text{ mA}$ , $T_A = -40\text{ to }125\text{ °C}$			0.5		
$V_{IL}$	Control input logic low	$T_A = -40\text{ to }125\text{ °C}$			0.8	V	
$V_{IH}$	Control input logic high	$T_A = -40\text{ to }125\text{ °C}$	2			V	
$I_I$	Control input current	$V_I = 9\text{ V}$ , $V_C = 6\text{ V}$		10		$\mu\text{A}$	
$C_O$	Output bypass capacitance	$\text{ESR} = 0.1\text{ to }10\text{ }\Omega$ , $I_O = 0\text{ to }100\text{ mA}$	2	10		$\mu\text{F}$	

**Table 24. Electrical characteristics for LE80C** (refer to the test circuits,  $T_J = 25\text{ °C}$ ,  $C_1 = 0.1\text{ }\mu\text{F}$ ,  $C_O = 2.2\text{ }\mu\text{F}$  unless otherwise specified.)

Symbol	Parameter	Test conditions	Min.	Typ.	Max.	Unit
$V_O$	Output voltage	$I_O = 10\text{ mA}$ , $V_I = 10\text{ V}$	7.84	8	8.16	V
		$I_O = 10\text{ mA}$ , $V_I = 10\text{ V}$ , $T_A = -25\text{ to }85\text{ °C}$	7.68		8.32	
$V_I$	Operating input voltage	$I_O = 100\text{ mA}$			18	V
$I_O$	Output current limit		150			mA
$\Delta V_O$	Line regulation	$V_I = 8.7\text{ to }18\text{ V}$ , $I_O = 0.5\text{ mA}$		5	35	mV
$\Delta V_O$	Load regulation	$V_I = 9\text{ V}$ , $I_O = 0.5\text{ to }100\text{ mA}$		3	25	mV
$I_d$	Quiescent current	$V_I = 9\text{ to }18\text{ V}$ , $I_O = 0\text{ mA}$	ON MODE	0.7	1.6	mA
		$V_I = 9\text{ to }18\text{ V}$ , $I_O = 100\text{ mA}$		1.7	3.6	
		$V_I = 9\text{ V}$	OFF MODE	70	140	$\mu\text{A}$
SVR	Supply voltage rejection	$I_O = 5\text{ mA}$ , $V_I = 10 \pm 1\text{ V}$	$f = 120\text{ Hz}$	72		dB
			$f = 1\text{ kHz}$	66		
			$f = 10\text{ kHz}$	57		
eN	Output noise voltage	$B = 10\text{ Hz to }100\text{ kHz}$		50		$\mu\text{V}$
$V_d$	Dropout voltage	$I_O = 100\text{ mA}$		0.2	0.4	V
		$I_O = 100\text{ mA}$ , $T_A = -40\text{ to }125\text{ °C}$			0.5	
$V_{IL}$	Control input logic low	$T_A = -40\text{ to }125\text{ °C}$			0.8	V
$V_{IH}$	Control input logic high	$T_A = -40\text{ to }125\text{ °C}$	2			V
$I_I$	Control input current	$V_I = 9\text{ V}$ , $V_C = 6\text{ V}$		10		$\mu\text{A}$
$C_O$	Output bypass capacitance	$\text{ESR} = 0.1\text{ to }10\text{ }\Omega$ , $I_O = 0\text{ to }100\text{ mA}$	2	10		$\mu\text{F}$

## 5 Typical performance characteristics

(unless otherwise specified  $V_{O(NOM)} = 3.3\text{ V}$ )

**Figure 4. Dropout voltage vs output current** **Figure 5. Dropout voltage vs temperature**

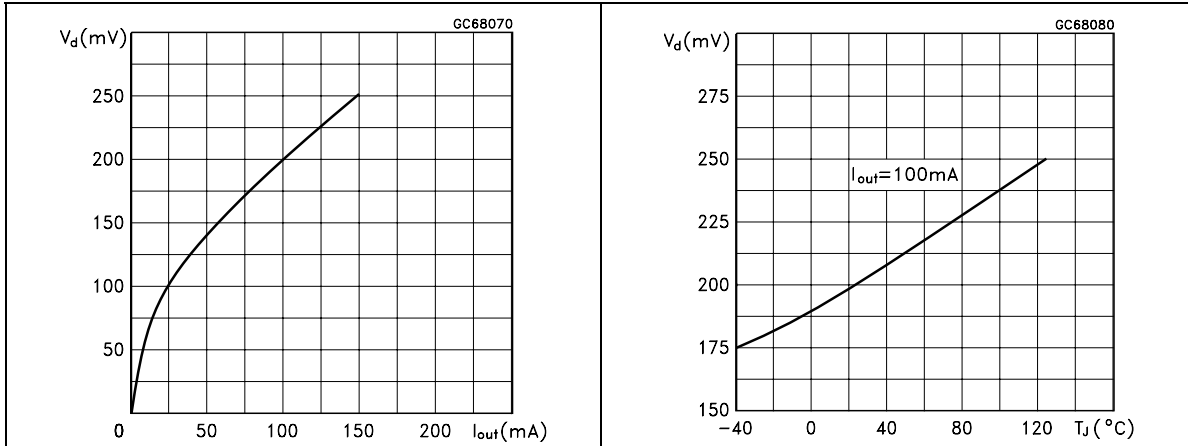

**Figure 6. Supply current vs temperature** **Figure 7. Supply current vs input voltage**

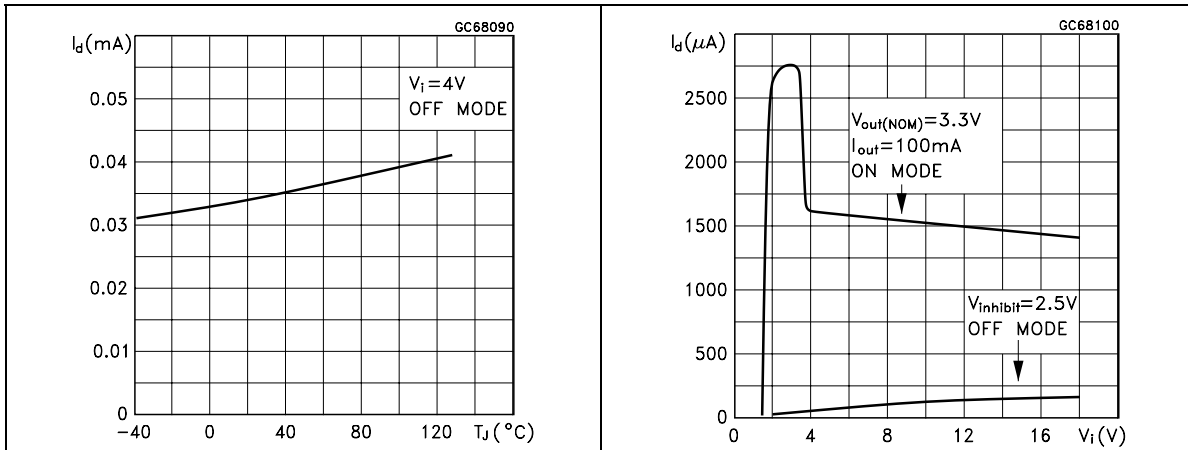

**Figure 8. Short circuit current vs dropout voltage** **Figure 9. SVR vs frequency**

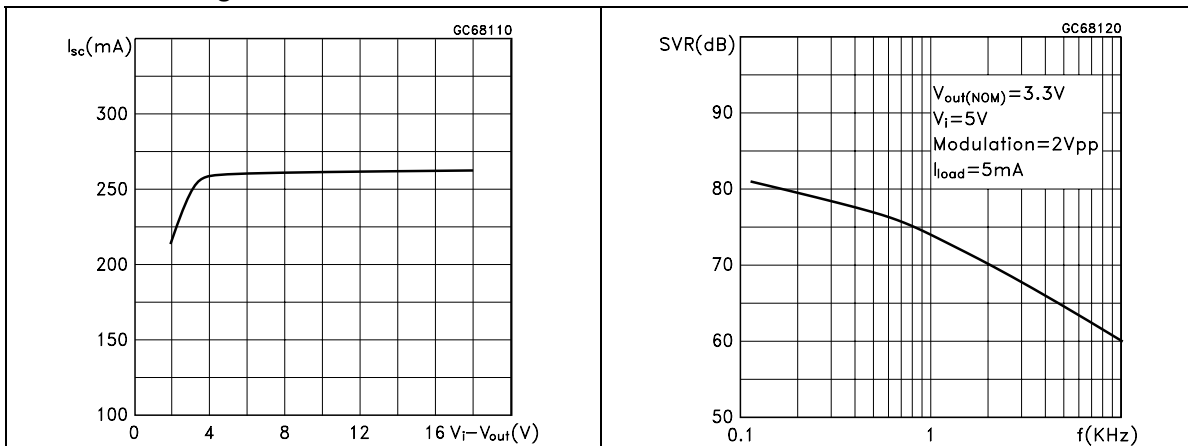



Figure 12. Multiple supply with ON/OFF toggle switch

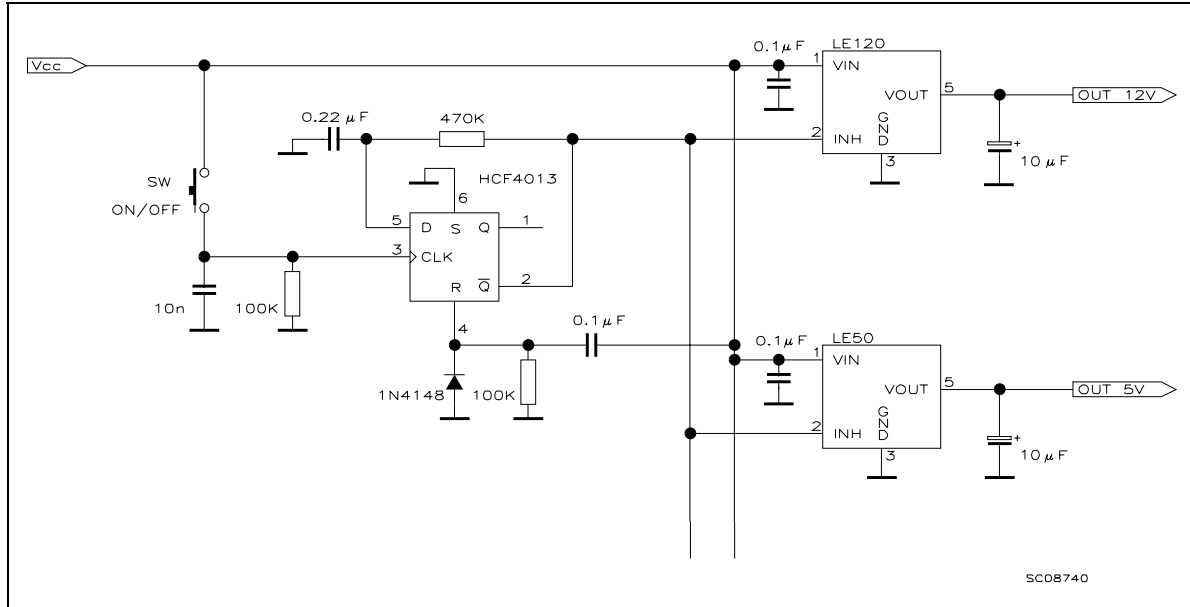
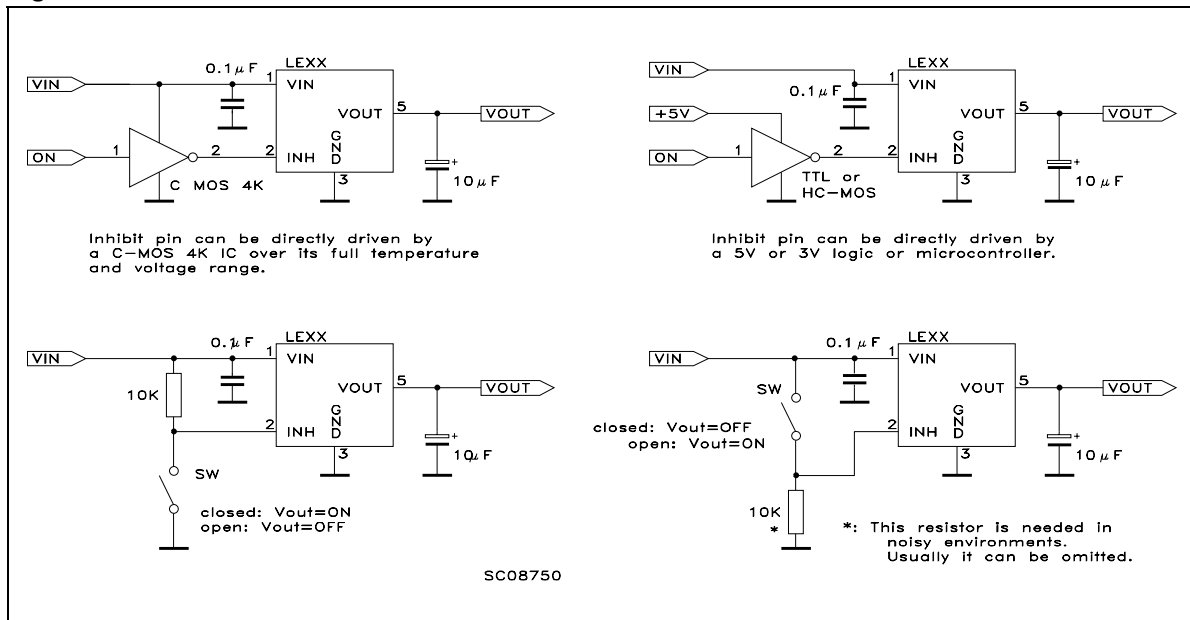

Figure 13. Basic inhibit functions



## 6 Package mechanical data

In order to meet environmental requirements, ST offers these devices in ECOPACK<sup>®</sup> packages. These packages have a lead-free second level interconnect. The category of second Level Interconnect is marked on the package and on the inner box label, in compliance with JEDEC Standard JESD97. The maximum ratings related to soldering conditions are also marked on the inner box label. ECOPACK is an ST trademark. ECOPACK specifications are available at: [www.st.com](http://www.st.com).



**SO-8 mechanical data**

Dim.	mm.			inch.		
	Min.	Typ.	Max.	Min.	Typ.	Max.
A	1.35		1.75	0.053		0.069
A1	0.10		0.25	0.04		0.010
A2	1.10		1.65	0.043		0.065
B	0.33		0.51	0.013		0.020
C	0.19		0.25	0.007		0.010
D	4.80		5.00	0.189		0.197
E	3.80		4.00	0.150		0.157
e		1.27			0.050	
H	5.80		6.20	0.228		0.244
h	0.25		0.50	0.010		0.020
L	0.40		1.27	0.016		0.050
k	8° (max.)					
ddd			0.1			0.04

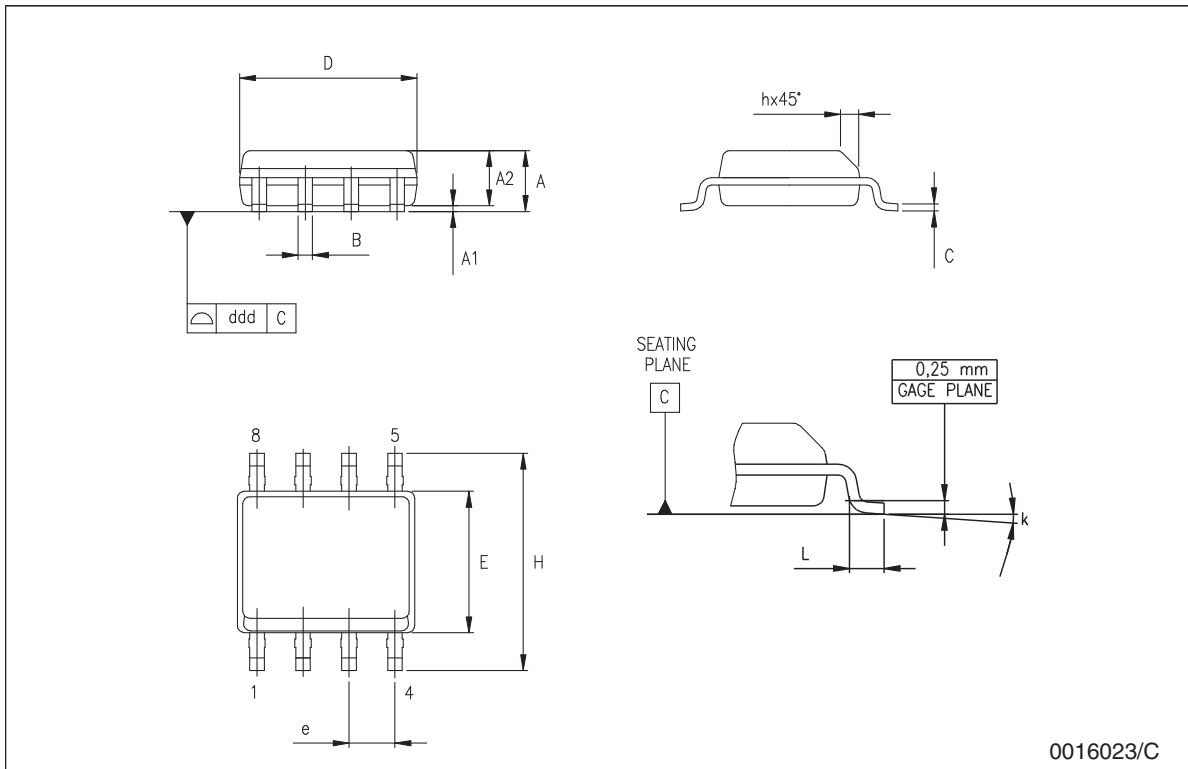

0016023/C

TO-92 mechanical data

Dim.	mm.			mils.		
	Min.	Typ.	Max.	Min.	Typ.	Max.
A	4.32		4.95	170.1		194.9
b	0.36		0.51	14.2		20.1
D	4.45		4.95	175.2		194.9
E	3.30		3.94	129.9		155.1
e	2.41		2.67	94.9		105.1
e1	1.14		1.40	44.9		55.1
L	12.7		15.49	500.0		609.8
R	2.16		2.41	85.0		94.9
S1	0.92		1.52	36.2		59.8
W	0.41		0.56	16.1		22.0
$\alpha$		5°			5°	

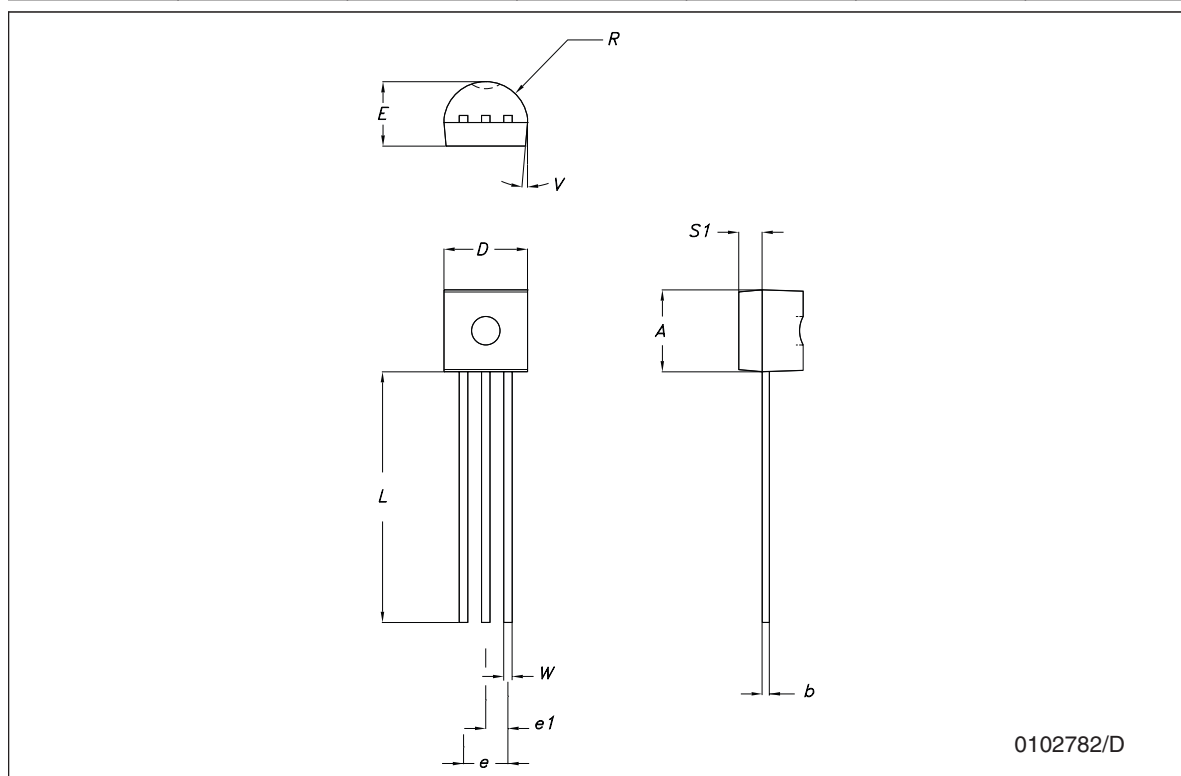

0102782/D

**Tape & reel SO-8 mechanical data**

Dim.	mm.			inch.		
	Min.	Typ.	Max.	Min.	Typ.	Max.
A			330			12.992
C	12.8		13.2	0.504		0.519
D	20.2			0.795		
N	60			2.362		
T			22.4			0.882
Ao	8.1		8.5	0.319		0.335
Bo	5.5		5.9	0.216		0.232
Ko	2.1		2.3	0.082		0.090
Po	3.9		4.1	0.153		0.161
P	7.9		8.1	0.311		0.319

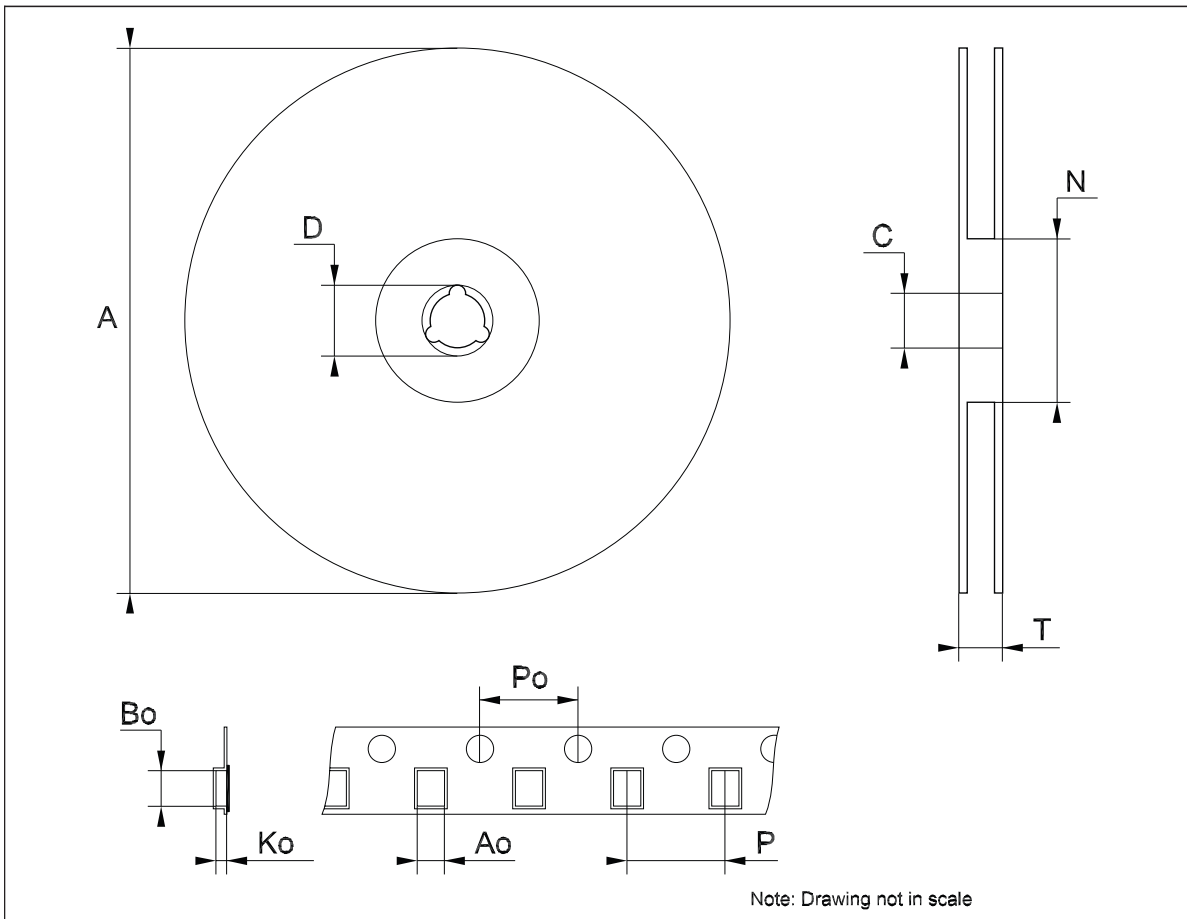

Tape & reel for TO-92 mechanical data

Dim.	mm.			inch.		
	Min.	Typ.	Max.	Min.	Typ.	Max.
A1		4.80			0.189	
T		3.80			0.150	
T1		1.60			0.063	
T2		2.30			0.091	
d		0.48			0.019	
P0	12.5		12.9	0.492		0.508
P2	5.65		7.05	0.222		0.278
F1, F2	2.44	2.54	2.94	0.096	0.100	0.116
delta H		±2			0.079	
W	17.5	18.00	19.0	0.689	0.709	0.748
W0	5.7		6.3	0.224		0.248
W1	8.5		9.25	0.335		0.364
W2		0.50			0.20	
H		18.50	18.70		0.728	0.726
H0	15.50		16.50	0.610		0.650
H1		25.00			0.984	
D0	3.8		4.2	0.150		0.165
t		0.90			0.035	
L1		3			0.118	
delta P		±1			0.039	
u		50			1.968	
Φ1		360			14.173	
Φ2		30			1.181	

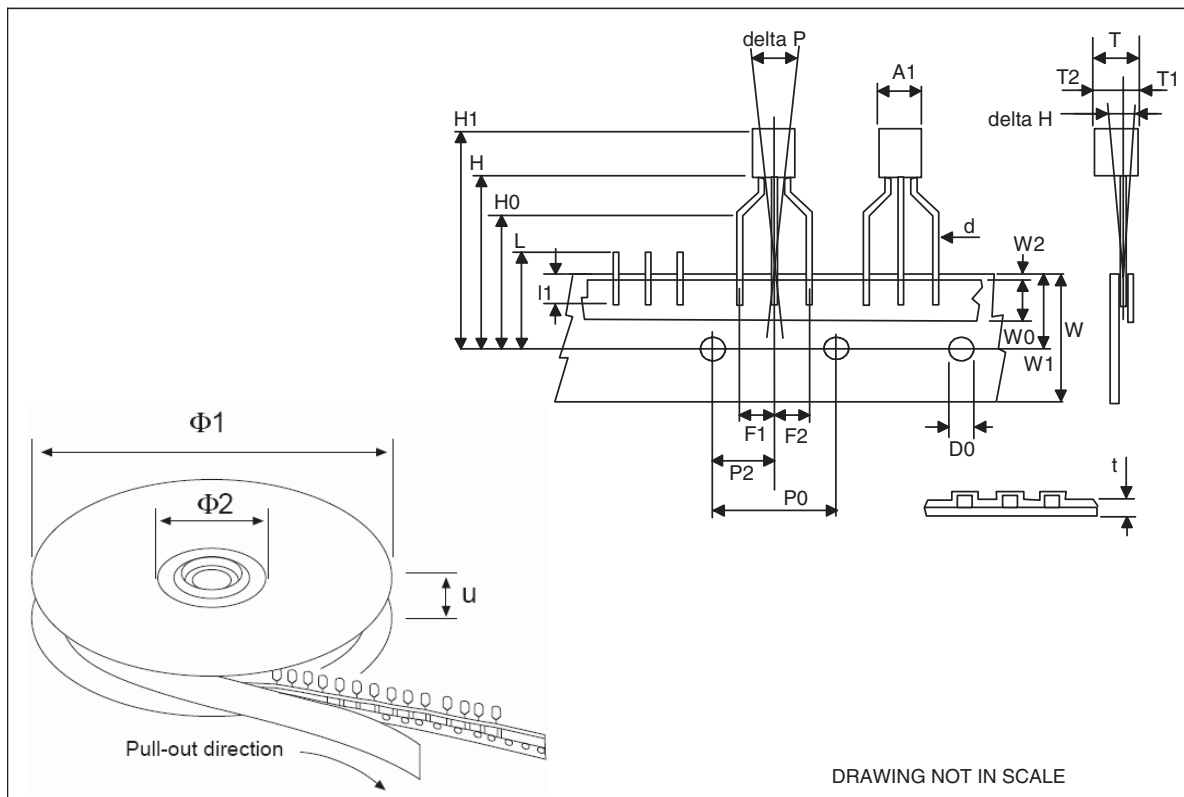

## 7 Order codes

Table 25. Order codes

Packages					Output voltage
SO-8	SO-8 (T&R)	TO-92	TO-92 (T&R)	TO-92 (Ammopak)	
	LE12ABD-TR <sup>(1)</sup>				1.25 V
LE25ABD	LE25ABD-TR <sup>(1)</sup>			LE25ABZ-AP <sup>(1)</sup>	2.5 V
	LE25CD-TR <sup>(1)</sup>		LE25CZ-TR <sup>(1)</sup>	LE25CZ-AP <sup>(1)</sup>	2.5 V
LE27ABD <sup>(1)</sup>	LE27ABD-TR <sup>(1)</sup>				2.7 V
LE27CD <sup>(1)</sup>					2.7 V
	LE30ABD-TR <sup>(1)</sup>		LE30ABZ-TR		3 V
	LE30CD-TR		LE30CZ-TR		3 V
		LE33ABZ	LE33ABZ-TR <sup>(1)</sup>	LE33ABZ-AP <sup>(1)</sup>	3.3 V
	LE33CD-TR	LE33CZ	LE33CZ-TR	LE33CZ-AP	3.3 V
	LE35ABD-TR <sup>(1)</sup>	LE35ABZ <sup>(1)</sup>	LE35ABZ-TR <sup>(1)</sup>	LE35ABZ-AP <sup>(1)</sup>	3.5 V
LE35CD <sup>(1)</sup>	LE35CD-TR <sup>(1)</sup>		LE35CZ-TR <sup>(1)</sup>	LE35CZ-AP <sup>(1)</sup>	3.5 V
	LE40ABD-TR <sup>(1)</sup>	LE40ABZ <sup>(1)</sup>	LE40ABZ-TR <sup>(1)</sup>	LE40ABZ-AP <sup>(1)</sup>	4 V
	LE40CD-TR <sup>(1)</sup>	LE40CZ	LE40CZ-TR <sup>(1)</sup>	LE40CZ-AP <sup>(1)</sup>	4 V
				LE45ABZ-AP <sup>(1)</sup>	4.5 V
	LE45CD-TR			LE45CZ-AP <sup>(1)</sup>	4.5 V
LE47ABD <sup>(1)</sup>	LE47ABD-TR <sup>(1)</sup>		LE47ABZ-TR <sup>(1)</sup>	LE47ABZ-AP <sup>(1)</sup>	4.7 V
	LE47CD-TR <sup>(1)</sup>	LE47CZ <sup>(1)</sup>	LE47CZ-TR <sup>(1)</sup>	LE47CZ-AP <sup>(1)</sup>	4.7 V
	LE50ABD-TR	LE50ABZ	LE50ABZ-TR	LE50ABZ-AP	5 V
	LE50CD-TR	LE50CZ	LE50CZ-TR	LE50CZ-AP	5 V
			LE80ABZ-TR <sup>(1)</sup>		8 V
	LE80CD-TR		LE80CZ-TR <sup>(1)</sup>		8 V

1. Available on request.

## 8 Revision history

**Table 26. Document revision history**

Date	Revision	Changes
09-Jul-2004	6	I <sub>O</sub> typ. and max. are changed in tab. 24 and 25 - pag. 14.
16-Mar-2005	7	Add Tape & Reel for TO-92 - Note on Table 3.
12-Feb-2007	8	Change value T <sub>OP</sub> on <a href="#">Table 2</a> .
26-Jul-2007	9	Add <a href="#">Table 1</a> in cover page.
29-Nov-2007	10	Modified: <a href="#">Table 25</a> .
12-Feb-2008	11	Modified: <a href="#">Table 25 on page 37</a> .
10-Jul-2008	12	Modified: <a href="#">Table 1 on page 1</a> and <a href="#">Table 25 on page 37</a> .

**Please Read Carefully:**

Information in this document is provided solely in connection with ST products. STMicroelectronics NV and its subsidiaries ("ST") reserve the right to make changes, corrections, modifications or improvements, to this document, and the products and services described herein at any time, without notice.

All ST products are sold pursuant to ST's terms and conditions of sale.

Purchasers are solely responsible for the choice, selection and use of the ST products and services described herein, and ST assumes no liability whatsoever relating to the choice, selection or use of the ST products and services described herein.

No license, express or implied, by estoppel or otherwise, to any intellectual property rights is granted under this document. If any part of this document refers to any third party products or services it shall not be deemed a license grant by ST for the use of such third party products or services, or any intellectual property contained therein or considered as a warranty covering the use in any manner whatsoever of such third party products or services or any intellectual property contained therein.

**UNLESS OTHERWISE SET FORTH IN ST'S TERMS AND CONDITIONS OF SALE ST DISCLAIMS ANY EXPRESS OR IMPLIED WARRANTY WITH RESPECT TO THE USE AND/OR SALE OF ST PRODUCTS INCLUDING WITHOUT LIMITATION IMPLIED WARRANTIES OF MERCHANTABILITY, FITNESS FOR A PARTICULAR PURPOSE (AND THEIR EQUIVALENTS UNDER THE LAWS OF ANY JURISDICTION), OR INFRINGEMENT OF ANY PATENT, COPYRIGHT OR OTHER INTELLECTUAL PROPERTY RIGHT.**

**UNLESS EXPRESSLY APPROVED IN WRITING BY AN AUTHORIZED ST REPRESENTATIVE, ST PRODUCTS ARE NOT RECOMMENDED, AUTHORIZED OR WARRANTED FOR USE IN MILITARY, AIR CRAFT, SPACE, LIFE SAVING, OR LIFE SUSTAINING APPLICATIONS, NOR IN PRODUCTS OR SYSTEMS WHERE FAILURE OR MALFUNCTION MAY RESULT IN PERSONAL INJURY, DEATH, OR SEVERE PROPERTY OR ENVIRONMENTAL DAMAGE. ST PRODUCTS WHICH ARE NOT SPECIFIED AS "AUTOMOTIVE GRADE" MAY ONLY BE USED IN AUTOMOTIVE APPLICATIONS AT USER'S OWN RISK.**

Resale of ST products with provisions different from the statements and/or technical features set forth in this document shall immediately void any warranty granted by ST for the ST product or service described herein and shall not create or extend in any manner whatsoever, any liability of ST.

ST and the ST logo are trademarks or registered trademarks of ST in various countries.

Information in this document supersedes and replaces all information previously supplied.

The ST logo is a registered trademark of STMicroelectronics. All other names are the property of their respective owners.

© 2008 STMicroelectronics - All rights reserved

STMicroelectronics group of companies

Australia - Belgium - Brazil - Canada - China - Czech Republic - Finland - France - Germany - Hong Kong - India - Israel - Italy - Japan - Malaysia - Malta - Morocco - Singapore - Spain - Sweden - Switzerland - United Kingdom - United States of America

[www.st.com](http://www.st.com)