

MPC875/MPC870

Hardware Specifications

This hardware specification contains detailed information on power considerations, DC/AC electrical characteristics, and AC timing specifications for the MPC875/MPC870. The CPU on the MPC875/MPC870 is a 32-bit PowerPC™ core that incorporates memory management units (MMUs) and instruction and data caches and that implements the PowerPC instruction set. This hardware specification covers the following topics:

1 Overview

The MPC875/MPC870 is a versatile single-chip integrated microprocessor and peripheral combination that can be used in a variety of controller applications and communications and networking systems. The MPC875/MPC870 provides enhanced ATM functionality over that of other ATM-enabled members of the MPC860 family.

Contents

1. Overview	1
2. Features	2
3. Maximum Tolerated Ratings	7
4. Thermal Characteristics	9
5. Power Dissipation	9
6. DC Characteristics	10
7. Thermal Calculation and Measurement	11
8. Power Supply and Power Sequencing	13
9. Mandatory Reset Configurations	14
10. Layout Practices	15
11. Bus Signal Timing	15
12. IEEE 1149.1 Electrical Specifications	44
13. CPM Electrical Characteristics	46
14. USB Electrical Characteristics	67
15. FEC Electrical Characteristics	67
16. Mechanical Data and Ordering Information	71
17. Document Revision History	82

Features

Table 1 shows the functionality supported by the members of the MPC875/MPC870.

Table 1. MPC875/870 Devices

Part	Cache		Ethernet		SCC	SMC	USB	Security Engine
	I Cache	D Cache	10BaseT	10/100				
MPC875	8 Kbyte	8 Kbyte	1	2	1	1	1	Yes
MPC870	8 Kbyte	8 Kbyte	—	2	—	1	1	No

2 Features

The MPC875/870 is comprised of three modules that each use the 32-bit internal bus: a MPC8xx core, a system integration unit (SIU), and a communications processor module (CPM).

The following list summarizes the key MPC875/870 features:

- Embedded MPC8xx core up to 133 MHz
- Maximum frequency operation of the external bus is 80 MHz (in 1:1 mode)
 - The 133-MHz core frequency supports 2:1 mode only.
 - The 66-/80-MHz core frequencies support both the 1:1 and 2:1 modes.
- Single-issue, 32-bit core (compatible with the PowerPC architecture definition) with thirty-two 32-bit general-purpose registers (GPRs)
 - The core performs branch prediction with conditional prefetch and without conditional execution.
 - 8-Kbyte data cache and 8-Kbyte instruction cache (see Table 1)
 - Instruction cache is two-way, set-associative with 256 sets in 2 blocks
 - Data cache is two-way, set-associative with 256 sets
 - Cache coherency for both instruction and data caches is maintained on 128-bit (4-word) cache blocks.
 - Caches are physically addressed, implement a least recently used (LRU) replacement algorithm, and are lockable on a cache block basis.
 - MMUs with 32-entry TLB, fully associative instruction and data TLBs
 - MMUs support multiple page sizes of 4, 16, and 512 Kbytes, and 8 Mbytes; 16 virtual address spaces and 16 protection groups
 - Advanced on-chip emulation debug mode
- Up to 32-bit data bus (dynamic bus sizing for 8, 16, and 32 bits)
- 32 address lines
- Memory controller (eight banks)
 - Contains complete dynamic RAM (DRAM) controller
 - Each bank can be a chip select or \overline{RAS} to support a DRAM bank.
 - Up to 30 wait states programmable per memory bank
 - Glueless interface to DRAM, SIMMS, SRAM, EPROMs, Flash EPROMs, and other memory devices
 - DRAM controller programmable to support most size and speed memory interfaces
 - Four \overline{CAS} lines, four \overline{WE} lines, and one \overline{OE} line

- Boot chip-select available at reset (options for 8-, 16-, or 32-bit memory)
- Variable block sizes (32 Kbyte–256 Mbyte)
- Selectable write protection
- On-chip bus arbitration logic
- General-purpose timers
 - Four 16-bit timers or two 32-bit timers
 - Gate mode can enable/disable counting.
 - Interrupt can be masked on reference match and event capture
- Two fast Ethernet controllers (FEC)—Two 10/100 Mbps Ethernet/IEEE 802.3 CDMA/CS that interface through MII and/or RMI interfaces
- System integration unit (SIU)
 - Bus monitor
 - Software watchdog
 - Periodic interrupt timer (PIT)
 - Clock synthesizer
 - Decrementer and time base
 - Reset controller
 - IEEE 1149.1 test access port (JTAG)
- Security engine is optimized to handle all the algorithms associated with IPsec, SSL/TLS, SRTP, 802.11i, and iSCSI processing. Available on the MPC875, the security engine contains a crypto-channel, a controller, and a set of crypto hardware accelerators (CHAs). The CHAs are:
 - Data encryption standard execution unit (DEU)
 - DES, 3DES
 - Two key (K1, K2, K1) or three key (K1, K2, K3)
 - ECB and CBC modes for both DES and 3DES
 - Advanced encryption standard unit (AESU)
 - Implements the Rijndael symmetric key cipher
 - ECB, CBC, and counter modes
 - 128-, 192-, and 256-bit key lengths
 - Message digest execution unit (MDEU)
 - SHA with 160- or 256-bit message digest
 - MD5 with 128-bit message digest
 - HMAC with either algorithm
 - Master/slave logic, with DMA
 - 32-bit address/32-bit data
 - Operation at 8xx bus frequency
 - Crypto-channel supporting multi-command descriptors
 - Integrated controller managing crypto-execution units
 - Buffer size of 256 bytes for each execution unit, with flow control for large data sizes
- Interrupts
 - Six external interrupt request (IRQ) lines

Features

- 12 port pins with interrupt capability
- 23 internal interrupt sources
- Programmable priority between SCCs
- Programmable highest priority request
- Communications processor module (CPM)
 - RISC controller
 - Communication-specific commands (for example, GRACEFUL STOP TRANSMIT, ENTER HUNT MODE, and RESTART TRANSMIT)
 - Supports continuous mode transmission and reception on all serial channels
 - 8-Kbytes of dual-port RAM
 - Several serial DMA (SDMA) channels to support the CPM
 - Three parallel I/O registers with open-drain capability
- On-chip 16 × 16 multiply accumulate controller (MAC)
 - One operation per clock (two-clock latency, one-clock blockage)
 - MAC operates concurrently with other instructions
 - FIR loop—Four clocks per four multiplies
- Four baud-rate generators
 - Independent (can be connected to any SCC or SMC)
 - Allows changes during operation
 - Autobaud support option
- SCC (serial communication controller)
 - Ethernet/IEEE 802.3 optional on the SCC, supporting full 10-Mbps operation
 - HDLC/SDLC
 - HDLC bus (implements an HDLC-based local area network (LAN))
 - Asynchronous HDLC to support point-to-point protocol (PPP)
 - AppleTalk
 - Universal asynchronous receiver transmitter (UART)
 - Synchronous UART
 - Serial infrared (IrDA)
 - Binary synchronous communication (BISYNC)
 - Totally transparent (bit streams)
 - Totally transparent (frame based with optional cyclic redundancy check (CRC))
- SMC (serial management channel)
 - UART (low-speed operation)
 - Transparent
- Universal serial bus (USB)—Supports operation as a USB function endpoint, a USB host controller, or both for testing purposes (loopback diagnostics)
 - USB 2.0 full-/low-speed compatible
 - The USB function mode has the following features:
 - Four independent endpoints support control, bulk, interrupt, and isochronous data transfers.

- CRC16 generation and checking
 - CRC5 checking
 - NRZI encoding/decoding with bit stuffing
 - 12- or 1.5-Mbps data rate
 - Flexible data buffers with multiple buffers per frame
 - Automatic retransmission upon transmit error
- The USB host controller has the following features:
 - Supports control, bulk, interrupt, and isochronous data transfers
 - CRC16 generation and checking
 - NRZI encoding/decoding with bit stuffing
 - Supports both 12- and 1.5-Mbps data rates (automatic generation of preamble token and data rate configuration). Note that low-speed operation requires an external hub.
 - Flexible data buffers with multiple buffers per frame
 - Supports local loopback mode for diagnostics (12 Mbps only)
- Serial peripheral interface (SPI)
 - Supports master and slave modes
 - Supports multiple-master operation on the same bus
- Inter-integrated circuit (I²C) port
 - Supports master and slave modes
 - Supports a multiple-master environment
- The MPC875 has a time-slot assigner (TSA) that supports one TDM bus (TDMb).
 - Allows SCC and SMC to run in multiplexed and/or non-multiplexed operation
 - Supports T1, CEPT, PCM highway, ISDN basic rate, ISDN primary rate, user defined
 - 1- or 8-bit resolution
 - Allows independent transmit and receive routing, frame synchronization, and clocking
 - Allows dynamic changes
 - Can be internally connected to two serial channels (one SCC and one SMC)
- PCMCIA interface
 - Master (socket) interface, release 2.1-compliant
 - Supports one independent PCMCIA socket on the MPC875/MPC870
 - 8 memory or I/O windows supported
- Debug interface
 - Eight comparators: four operate on instruction address, two operate on data address, and two operate on data
 - Supports conditions: = ≠ < >
 - Each watchpoint can generate a break point internally.
- Normal high and normal low power modes to conserve power
- 1.8-V core and 3.3-V I/O operation with 5-V TTL compatibility
- The MPC875/870 comes in a 256-pin ball grid array (PBGA) package.

Features

The MPC875 block diagram is shown in Figure 1.

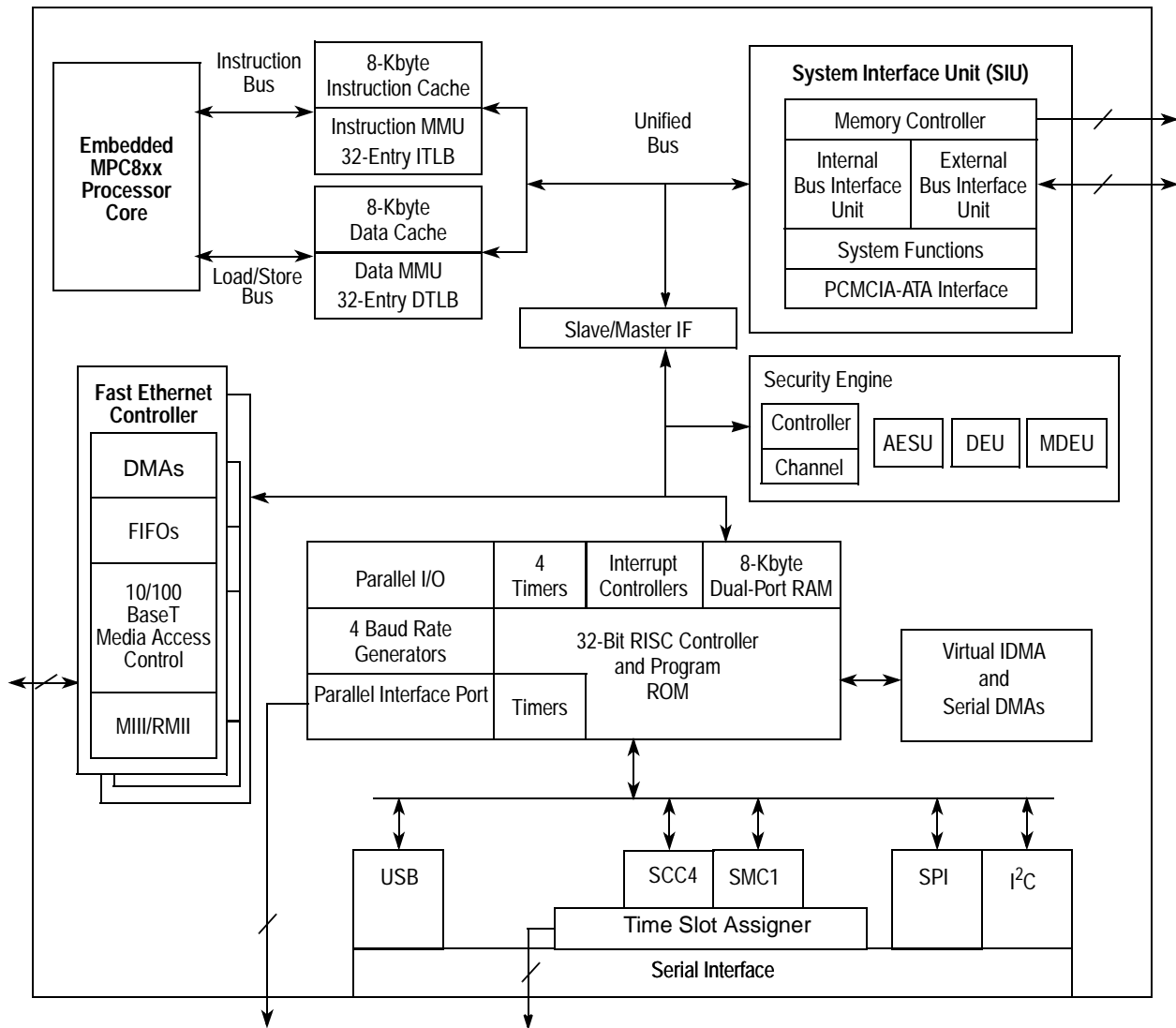

Figure 1. MPC875 Block Diagram

The MPC870 block diagram is shown in Figure 2.

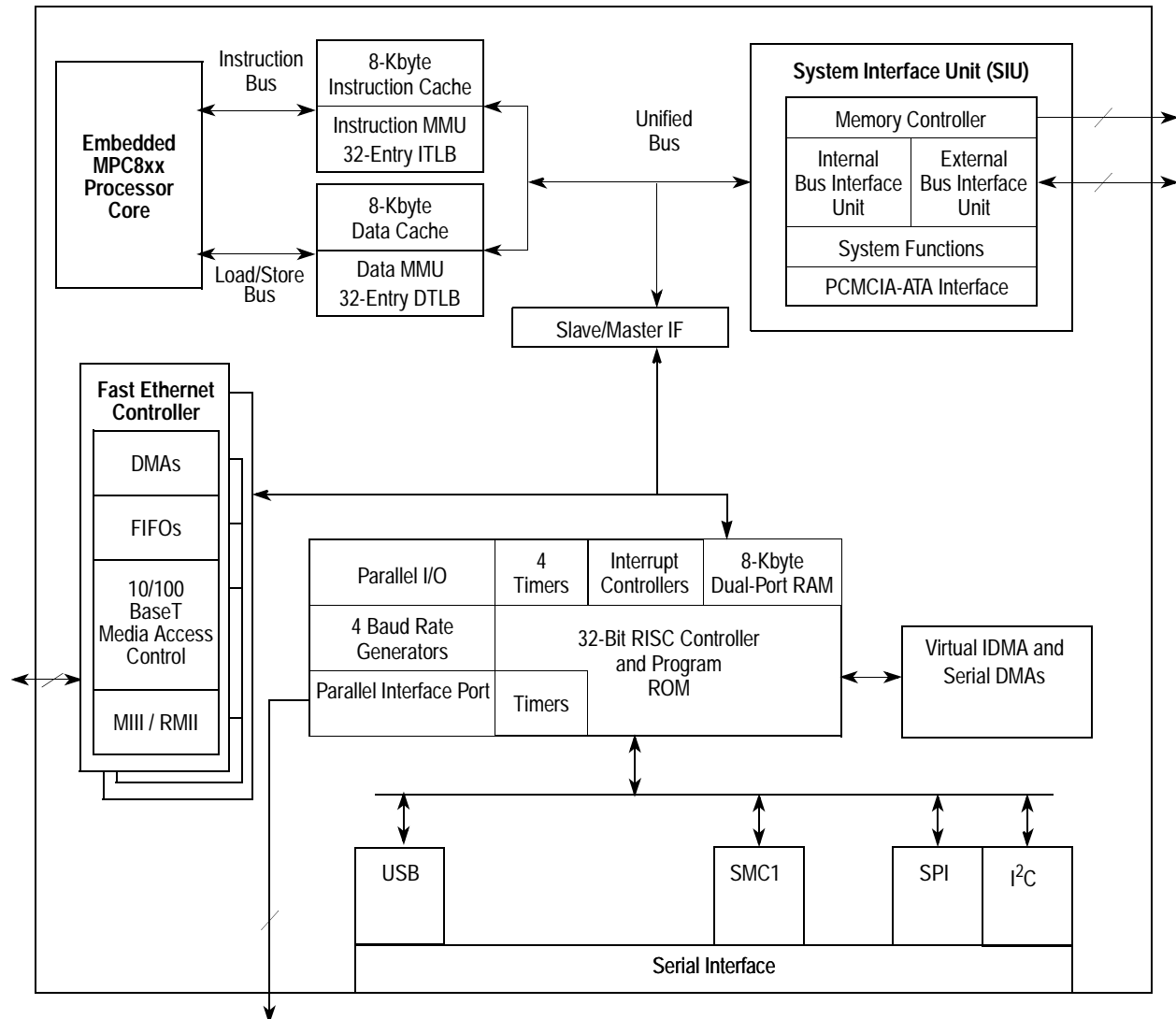

Figure 2. MPC870 Block Diagram

3 Maximum Tolerated Ratings

This section provides the maximum tolerated voltage and temperature ranges for the MPC875/870. Table 2 displays the maximum tolerated ratings, and Table 3 displays the operating temperatures.

Table 2. Maximum Tolerated Ratings

Rating	Symbol	Value	Unit
Supply voltage ¹	V_{DDL} (core voltage)	-0.3 to 3.4	V
	V_{DDH} (I/O voltage)	-0.3 to 4	V
	V_{DDSYN}	-0.3 to 3.4	V
	Difference between V_{DDL} and V_{DDSYN}	<100	mV
Input voltage ²	V_{in}	GND - 0.3 to V_{DDH}	V
Storage temperature range	T_{stg}	-55 to +150	°C

¹ The power supply of the device must start its ramp from 0.0 V.

² Functional operating conditions are provided with the DC electrical specifications in Table 6. Absolute maximum ratings are stress ratings only; functional operation at the maxima is not guaranteed. Stress beyond those listed may affect device reliability or cause permanent damage to the device.

Caution: All inputs that tolerate 5 V cannot be more than 2.5 V greater than V_{DDH} . This restriction applies to power up and normal operation (that is, if the MPC875/870 is unpowered, a voltage greater than 2.5 V must not be applied to its inputs).

Table 3. Operating Temperatures

Rating	Symbol	Value	Unit
Temperature ¹ (standard)	$T_{A(min)}$	0	°C
	$T_{j(max)}$	95	°C
Temperature (extended)	$T_{A(min)}$	-40	°C
	$T_{j(max)}$	100	°C

¹ Minimum temperatures are guaranteed as ambient temperature, T_A . Maximum temperatures are guaranteed as junction temperature, T_j .

This device contains circuitry protecting against damage due to high-static voltage or electrical fields; however, it is advised that normal precautions be taken to avoid application of any voltages higher than maximum-rated voltages to this high-impedance circuit. Reliability of operation is enhanced if unused inputs are tied to an appropriate logic voltage level (for example, either GND or V_{DDH}).

4 Thermal Characteristics

Table 4 shows the thermal characteristics for the MPC875/870.

Table 4. MPC875/870 Thermal Resistance Data

Rating	Environment		Symbol	Value	Unit
Junction-to-ambient ¹	Natural convection	Single-layer board (1s)	$R_{\theta JA}$ ²	43	°C/W
		Four-layer board (2s2p)	$R_{\theta JMA}$ ³	29	
	Airflow (200 ft/min)	Single-layer board (1s)	$R_{\theta JMA}$ ³	36	
		Four-layer board (2s2p)	$R_{\theta JMA}$ ³	26	
Junction-to-board ⁴			$R_{\theta JB}$	20	
Junction-to-case ⁵			$R_{\theta JC}$	10	
Junction-to-package top ⁶	Natural convection		Ψ_{JT}	2	
	Airflow (200 ft/min)		Ψ_{JT}	2	

¹ Junction temperature is a function of on-chip power dissipation, package thermal resistance, mounting site (board) temperature, ambient temperature, airflow, power dissipation of other components on the board, and board thermal resistance.

² Per SEMI G38-87 and JEDEC JESD51-2 with the single-layer board horizontal.

³ Per JEDEC JESD51-6 with the board horizontal.

⁴ Thermal resistance between the die and the printed circuit board per JEDEC JESD51-8. Board temperature is measured on the top surface of the board near the package.

⁵ Indicates the average thermal resistance between the die and the case top surface as measured by the cold plate method (MIL SPEC-883 Method 1012.1) with the cold plate temperature used for the case temperature. For exposed pad packages where the pad would be expected to be soldered, junction-to-case thermal resistance is a simulated value from the junction to the exposed pad without contact resistance.

⁶ Thermal characterization parameter indicating the temperature difference between the package top and the junction temperature per JEDEC JESD51-2.

5 Power Dissipation

Table 5 provides information on power dissipation. The modes are 1:1, where CPU and bus speeds are equal, and 2:1, where CPU frequency is twice bus speed.

Table 5. Power Dissipation (P_D)

Die Revision	Bus Mode	Frequency	Typical ¹	Maximum ²	Unit
0	1:1	66 MHz	310	390	mW
		80 MHz	350	430	mW
	2:1	133 MHz	430	495	mW

¹ Typical power dissipation is measured at $V_{DDL} = V_{DDSYN} = 1.8$ V, and V_{DDH} is at 3.3 V.

DC Characteristics

² Maximum power dissipation at $V_{DDL} = V_{DDSYN} = 1.9$ V, and V_{DDH} is at 3.5 V.

NOTE

The values in Table 5 represent V_{DDL} -based power dissipation and do not include I/O power dissipation over V_{DDH} . I/O power dissipation varies widely by application due to buffer current, depending on external circuitry.

The V_{DDSYN} power dissipation is negligible.

6 DC Characteristics

Table 6 provides the DC electrical characteristics for the MPC875/870.

Table 6. DC Electrical Specifications

Characteristic	Symbol	Min	Max	Unit
Operating voltage	V_{DDH} (I/O)	3.135	3.465	V
	V_{DDL} (Core)	1.7	1.9	V
	V_{DDSYN} ¹	1.7	1.9	V
	Difference between V_{DDL} and V_{DDSYN}	—	100	mV
Input high voltage (all inputs except EXTAL and EXTCLK) ²	V_{IH}	2.0	3.465	V
Input low voltage ³	V_{IL}	GND	0.8	V
EXTAL, EXTCLK input high voltage	V_{IHC}	$0.7 \times V_{DDH}$	V_{DDH}	V
Input leakage current, $V_{in} = 5.5$ V (except TMS, \overline{TRST} , DSCK and DSDI pins) for 5-V tolerant pins ¹	I_{in}	—	100	μ A
Input leakage current, $V_{in} = V_{DDH}$ (except TMS, \overline{TRST} , DSCK, and DSDI)	I_{in}	—	10	μ A
Input leakage current, $V_{in} = 0$ V (except TMS, \overline{TRST} , DSCK and DSDI pins)	I_{in}	—	10	μ A
Input capacitance ⁴	C_{in}	—	20	pF
Output high voltage, $I_{OH} = -2.0$ mA, $V_{DDH} = 3.0$ V except XTAL and open-drain pins	V_{OH}	2.4	—	V
Output low voltage $I_{OL} = 2.0$ mA (CLKOUT) $I_{OL} = 3.2$ mA ⁵ $I_{OL} = 5.3$ mA ⁶ $I_{OL} = 7.0$ mA (TXD1/PA14, TXD2/PA12) $I_{OL} = 8.9$ mA (\overline{TS} , \overline{TA} , \overline{TEA} , \overline{BI} , \overline{BB} , \overline{HRESET} , \overline{SRESET})	V_{OL}	—	0.5	V

¹ The difference between V_{DDL} and V_{DDSYN} cannot be more than 100 mV.

² The signals PA[0:15], PB[14:31], PC[4:15], PD[3:15], PE[14:31], TDI, TDO, TCK, \overline{TRST} , TMS, MII1_TXEN, MII_MDIO are 5-V tolerant. The minimum voltage is still 2.0 V.

³ V_{IL} (max) for the I²C interface is 0.8 V rather than the 1.5 V as specified in the I²C standard.

⁴ Input capacitance is periodically sampled.

⁵ A(0:31), TSIZ0/ $\overline{\text{REG}}$, TSIZ1, D(0:31), $\overline{\text{IRQ}}$ (2:4), $\overline{\text{IRQ6}}$, $\overline{\text{RD/WR}}$, $\overline{\text{BURST}}$, IP_B(0:1), PA(0:4), PA(6:7), PA(10:11), PA15, PB19, PB(23:31), PC(6:7), PC(10:13), PC15, PD8, PE(14:31), MII1_CRCS, MII_MDIO, MII1_TXEN, MII1_COL.

⁶ $\overline{\text{BDIP/GPL_B}}$ (5), $\overline{\text{BR}}$, $\overline{\text{BG}}$, FRZ/ $\overline{\text{IRQ6}}$, $\overline{\text{CS}}$ (0:7), $\overline{\text{WE}}$ (0:3), $\overline{\text{BS_A}}$ (0:3), $\overline{\text{GPL_A0/GPL_B0}}$, $\overline{\text{OE/GPL_A1/GPL_B1}}$, $\overline{\text{GPL_A(2:3)/GPL_B(2:3)/CS(2:3)}}$, UPWAITA/ $\overline{\text{GPL_A4}}$, UPWAITB/ $\overline{\text{GPL_B4}}$, $\overline{\text{GPL_A5}}$, ALE_A, $\overline{\text{CE1_A}}$, $\overline{\text{CE2_A}}$, OP(0:3) BADDR(28:30)

7 Thermal Calculation and Measurement

For the following discussions, $P_D = (V_{\text{DDL}} \times I_{\text{DDL}}) + P_{\text{I/O}}$, where $P_{\text{I/O}}$ is the power dissipation of the I/O drivers.

NOTE

The V_{DDSYN} power dissipation is negligible.

7.1 Estimation with Junction-to-Ambient Thermal Resistance

An estimation of the chip junction temperature, T_J , in °C can be obtained from the following equation:

$$T_J = T_A + (R_{\theta\text{JA}} \times P_D)$$

where:

T_A = ambient temperature °C

$R_{\theta\text{JA}}$ = package junction-to-ambient thermal resistance (°C/W)

P_D = power dissipation in package

The junction-to-ambient thermal resistance is an industry standard value that provides a quick and easy estimation of thermal performance. However, the answer is only an estimate; test cases have demonstrated that errors of a factor of two (in the quantity $T_J - T_A$) are possible.

7.2 Estimation with Junction-to-Case Thermal Resistance

Historically, thermal resistance has frequently been expressed as the sum of a junction-to-case thermal resistance and a case-to-ambient thermal resistance:

$$R_{\theta\text{JA}} = R_{\theta\text{JC}} + R_{\theta\text{CA}}$$

where:

$R_{\theta\text{JA}}$ = junction-to-ambient thermal resistance (°C/W)

$R_{\theta\text{JC}}$ = junction-to-case thermal resistance (°C/W)

$R_{\theta\text{CA}}$ = case-to-ambient thermal resistance (°C/W)

$R_{\theta\text{JC}}$ is device-related and cannot be influenced by the user. The user adjusts the thermal environment to affect the case-to-ambient thermal resistance, $R_{\theta\text{CA}}$. For instance, the user can change the airflow around the device, add a heat sink, change the mounting arrangement on the printed circuit board, or change the thermal dissipation on the printed circuit board surrounding the device. This thermal model is most useful for ceramic packages with heat sinks where some 90% of the heat flows through the case and the heat sink to the ambient environment. For most packages, a better model is required.

7.3 Estimation with Junction-to-Board Thermal Resistance

A simple package thermal model that has demonstrated reasonable accuracy (about 20%) is a two-resistor model consisting of a junction-to-board and a junction-to-case thermal resistance. The junction-to-case thermal resistance covers the situation where a heat sink is used or where a substantial amount of heat is dissipated from the top of the package. The junction-to-board thermal resistance describes the thermal performance when most of the heat is conducted to the printed circuit board. It has been observed that the thermal performance of most plastic packages and especially PBGA packages is strongly dependent on the board temperature. If the board temperature is known, an estimate of the junction temperature in the environment can be made using the following equation:

$$T_J = T_B + (R_{\theta JB} \times P_D)$$

where:

$R_{\theta JB}$ = junction-to-board thermal resistance (°C/W)

T_B = board temperature °C

P_D = power dissipation in package

If the board temperature is known and the heat loss from the package case to the air can be ignored, acceptable predictions of junction temperature can be made. For this method to work, the board and board mounting must be similar to the test board used to determine the junction-to-board thermal resistance, namely a 2s2p (board with a power and a ground plane) and vias attaching the thermal balls to the ground plane.

7.4 Estimation Using Simulation

When the board temperature is not known, a thermal simulation of the application is needed. The simple two-resistor model can be used with the thermal simulation of the application [2], or a more accurate and complex model of the package can be used in the thermal simulation.

7.5 Experimental Determination

To determine the junction temperature of the device in the application after prototypes are available, the thermal characterization parameter (Ψ_{JT}) can be used to determine the junction temperature with a measurement of the temperature at the top center of the package case using the following equation:

$$T_J = T_T + (\Psi_{JT} \times P_D)$$

where:

Ψ_{JT} = thermal characterization parameter

T_T = thermocouple temperature on top of package

P_D = power dissipation in package

The thermal characterization parameter is measured per the JESD51-2 specification published by JEDEC using a 40 gauge type T thermocouple epoxied to the top center of the package case. The thermocouple should be positioned so that the thermocouple junction rests on the package. A small amount of epoxy is placed over the thermocouple junction and over about 1 mm of wire extending from the junction. The thermocouple wire is placed flat against the package case to avoid measurement errors caused by the cooling effects of the thermocouple wire.

7.6 References

- | | |
|---|---|
| Semiconductor Equipment and Materials International
805 East Middlefield Rd
Mountain View, CA 94043 | (415) 964-5111 |
| MIL-SPEC and EIA/JESD (JEDEC) specifications
(Available from Global Engineering Documents) | 800-854-7179 or
303-397-7956 |
| JEDEC Specifications | http://www.jedec.org |
1. C.E. Triplett and B. Joiner, “An Experimental Characterization of a 272 PBGA Within an Automotive Engine Controller Module,” Proceedings of SemiTherm, San Diego, 1998, pp. 47-54.
 2. B. Joiner and V. Adams, “Measurement and Simulation of Junction to Board Thermal Resistance and Its Application in Thermal Modeling,” Proceedings of SemiTherm, San Diego, 1999, pp. 212-220.

8 Power Supply and Power Sequencing

This section provides design considerations for the MPC875/870 power supply. The MPC875/870 has a core voltage (V_{DDL}) and PLL voltage (V_{DDSYN}), which both operate at a lower voltage than the I/O voltage V_{DDH} . The I/O section of the MPC875/870 is supplied with 3.3 V across V_{DDH} and V_{SS} (GND).

The signals PA[0:3], PA[8:11], PB15, PB[24:25]; PB[28:31], PC[4:7], PC[12:13], PC15] PD[3:15], TDI, TDO, TCK, \overline{TRST} , TMS, MII_TXEN, and MII_MDIO are 5-V tolerant. No input can be more than 2.5 V greater than V_{DDH} . In addition, 5 V-tolerant pins cannot exceed 5.5 V, and remaining input pins cannot exceed 3.465 V. This restriction applies to power up/down and normal operation.

One consequence of multiple power supplies is that when power is initially applied, the voltage rails ramp up at different rates. The rates depend on the nature of the power supply, the type of load on each power supply, and the manner in which different voltages are derived. The following restrictions apply:

- V_{DDL} must not exceed V_{DDH} during power up and power down.
- V_{DDL} must not exceed 1.9 V, and V_{DDH} must not exceed 3.465 V.

These cautions are necessary for the long-term reliability of the part. If they are violated, the electrostatic discharge (ESD) protection diodes are forward-biased, and excessive current can flow through these diodes. If the system power supply design does not control the voltage sequencing, the circuit shown in Figure 3 can be added to meet these requirements. The MUR420 Schottky diodes control the maximum potential difference between the external bus and core power supplies on power up, and the 1N5820 diodes regulate the maximum potential difference on power down.

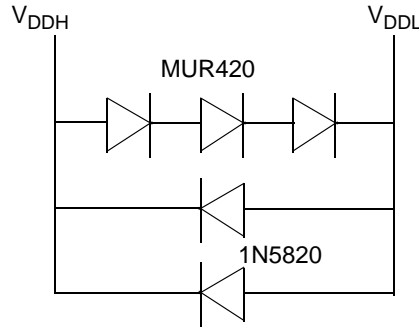

Figure 3. Example Voltage Sequencing Circuit

9 Mandatory Reset Configurations

The MPC875/870 requires a mandatory configuration during reset.

If hardware reset configuration word (HRCW) is enabled, the HRCW[DBGC] value needs to be set to binary X1 in the HRCW and the SIUMCR[DBGC] should be programmed with the same value in the boot code after reset. This can be done by asserting the $\overline{\text{RSTCONF}}$ during $\overline{\text{HRESET}}$ assertion.

If HRCW is disabled, the SIUMCR[DBGC] should be programmed with binary X1 in the boot code after reset by negating the $\overline{\text{RSTCONF}}$ during the $\overline{\text{HRESET}}$ assertion.

The MBMR[GPLB4DIS], PAPAN, PADIR, PBPAN, PBDIR, PCPAN, and PCDIR need to be configured with the mandatory values in Table 7 in the boot code after the reset is negated.

Table 7. Mandatory Reset Configuration of MPC875/870

Register/Configuration	Field	Value (binary)
HRCW (Hardware reset configuration word)	HRCW[DBGC]	X1
SIUMCR (SIU module configuration register)	SIUMCR[DBGC]	X1
MBMR (Machine B mode register)	MBMR[GPLB4DIS]	0
PAPAN (Port A pin assignment register)	PAPAN[5:9] PAPAN[12:13]	0
PADIR (Port A data direction register)	PADIR[5:9] PADIR[12:13]	0
PBPAN (Port B pin assignment register)	PBPAN[14:18] PBPAN[20:22]	0
PBDIR (Port B data direction register)	PBDIR[14:8] PBDIR[20:22]	0
PCPAN (Port C pin assignment register)	PCPAN[4:5] PCPAN[8:9] PCPAN[14]	0

Table 7. Mandatory Reset Configuration of MPC875/870 (continued)

Register/Configuration	Field	Value (binary)
PCDIR (Port C data direction register)	PCDIR[4:5] PCDIR[8:9] PCDIR[14]	0
PDPAR (Port D pin assignment register)	PDPAR[3:7] PDPAR[9:5]	0
PDDIR (Port D data direction register)	PDDIR[3:7] PDDIR[9:15]	0

10 Layout Practices

Each V_{DD} pin on the MPC875/870 should be provided with a low-impedance path to the board's supply. Each GND pin should likewise be provided with a low-impedance path to ground. The power supply pins drive distinct groups of logic on chip. The V_{DD} power supply should be bypassed to ground using at least four 0.1- μ F bypass capacitors located as close as possible to the four sides of the package. Each board designed should be characterized and additional appropriate decoupling capacitors should be used if required. The capacitor leads and associated printed circuit traces connecting to chip V_{DD} and GND should be kept to less than half an inch per capacitor lead. At a minimum, a four-layer board employing two inner layers as V_{DD} and GND planes should be used.

All output pins on the MPC875/870 have fast rise and fall times. Printed circuit (PC) trace interconnection length should be minimized in order to minimize undershoot and reflections caused by these fast output switching times. This recommendation particularly applies to the address and data buses. Maximum PC trace lengths of six inches are recommended. Capacitance calculations should consider all device loads as well as parasitic capacitances due to the PC traces. Attention to proper PCB layout and bypassing becomes especially critical in systems with higher capacitive loads because these loads create higher transient currents in the V_{DD} and GND circuits. Pull up all unused inputs or signals that will be inputs during reset. Special care should be taken to minimize the noise levels on the PLL supply pins. For more information, please refer to Section 14.4.3, "Clock Synthesizer Power (V_{DDSYN} , V_{SSSYN} , V_{SSSYN1})," of the *MPC885 PowerQUICC Family User's Manual*.

11 Bus Signal Timing

The maximum bus speed supported by the MPC875/870 is 80 MHz. Higher-speed parts must be operated in half-speed bus mode (for example, an MPC875/870 used at 133 MHz must be configured for a 66 MHz bus). Table 8 shows the frequency ranges for standard part frequencies in 1:1 bus mode, and Table 9 shows the frequency ranges for standard part frequencies in 2:1 bus mode.

Table 8. Frequency Ranges for Standard Part Frequencies (1:1 Bus Mode)

Part Frequency	66 MHz		80 MHz	
	Min	Max	Min	Max
Core frequency	40	66.67	40	80
Bus frequency	40	66.67	40	80

Table 9. Frequency Ranges for Standard Part Frequencies (2:1 Bus Mode)

Part Frequency	66 MHz		80 MHz		133 MHz	
	Min	Max	Min	Max	Min	Max
Core frequency	40	66.67	40	80	40	133
Bus frequency	20	33.33	20	40	20	66

Table 10 provides the bus operation timing for the MPC875/870 at 33, 40, 66, and 80 MHz.

The timing for the MPC875/870 bus shown assumes a 50-pF load for maximum delays and a 0-pF load for minimum delays. CLKOUT assumes a 100-pF load maximum delay

Table 10. Bus Operation Timings

Num	Characteristic	33 MHz		40 MHz		66 MHz		80 MHz		Unit
		Min	Max	Min	Max	Min	Max	Min	Max	
B1	Bus period (CLKOUT), see Table 8	—	—	—	—	—	—	—	—	ns
B1a	EXTCLK to CLKOUT phase skew - If CLKOUT is an integer multiple of EXTCLK, then the rising edge of EXTCLK is aligned with the rising edge of CLKOUT. For a non-integer multiple of EXTCLK, this synchronization is lost, and the rising edges of EXTCLK and CLKOUT have a continuously varying phase skew.	-2	+2	-2	+2	-2	+2	-2	+2	ns
B1b	CLKOUT frequency jitter peak-to-peak	—	1	—	1	—	1	—	1	ns
B1c	Frequency jitter on EXTCLK	—	0.50	—	0.50	—	0.50	—	0.50	%
B1d	CLKOUT phase jitter peak-to-peak for OSCLK ≥ 15 MHz	—	4	—	4	—	4	—	4	ns
	CLKOUT phase jitter peak-to-peak for OSCLK < 15 MHz	—	5	—	5	—	5	—	5	ns
B2	CLKOUT pulse width low (MIN = 0.4 × B1, MAX = 0.6 × B1)	12.1	18.2	10.0	15.0	6.1	9.1	5.0	7.5	ns
B3	CLKOUT pulse width high (MIN = 0.4 × B1, MAX = 0.6 × B1)	12.1	18.2	10.0	15.0	6.1	9.1	5.0	7.5	ns
B4	CLKOUT rise time	—	4.00	—	4.00	—	4.00	—	4.00	ns
B5	CLKOUT fall time	—	4.00	—	4.00	—	4.00	—	4.00	ns
B7	CLKOUT to A(0:31), BADDR(28:30), RD/WR, BURST, D(0:31) output hold (MIN = 0.25 × B1)	7.60	—	6.30	—	3.80	—	3.13	—	ns
B7a	CLKOUT to TSIZE(0:1), REG, RSV, BDIP, PTR output hold (MIN = 0.25 × B1)	7.60	—	6.30	—	3.80	—	3.13	—	ns
B7b	CLKOUT to BR, BG, FRZ, VFLS(0:1), VF(0:2) IWP(0:2), LWP(0:1), STS output hold (MIN = 0.25 × B1)	7.60	—	6.30	—	3.80	—	3.13	—	ns

Table 10. Bus Operation Timings (continued)

Num	Characteristic	33 MHz		40 MHz		66 MHz		80 MHz		Unit
		Min	Max	Min	Max	Min	Max	Min	Max	
B8	CLKOUT to A(0:31), BADDR(28:30) RD/WR, BURST, D(0:31) valid (MAX = 0.25 × B1 + 6.3)	—	13.80	—	12.50	—	10.00	—	9.43	ns
B8a	CLKOUT to TSIZ(0:1), REG, RSV, BDIP, PTR valid (MAX = 0.25 × B1 + 6.3)	—	13.80	—	12.50	—	10.00	—	9.43	ns
B8b	CLKOUT to BR, BG, VFLS(0:1), VF(0:2), IWP(0:2), FRZ, LWP(0:1), STS valid ² (MAX = 0.25 × B1 + 6.3)	—	13.80	—	12.50	—	10.00	—	9.43	ns
B9	CLKOUT to A(0:31), BADDR(28:30), RD/WR, BURST, D(0:31), TSIZ(0:1), REG, RSV, PTR High-Z (MAX = 0.25 × B1 + 6.3)	7.60	13.80	6.30	12.50	3.80	10.00	3.13	9.43	ns
B11	CLKOUT to TS, BB assertion (MAX = 0.25 × B1 + 6.0)	7.60	13.60	6.30	12.30	3.80	9.80	3.13	9.13	ns
B11a	CLKOUT to TA, BI assertion (when driven by the memory controller or PCMCIA interface) (MAX = 0.00 × B1 + 9.30 ¹)	2.50	9.30	2.50	9.30	2.50	9.80	2.5	9.3	ns
B12	CLKOUT to TS, BB negation (MAX = 0.25 × B1 + 4.8)	7.60	12.30	6.30	11.00	3.80	8.50	3.13	7.92	ns
B12a	CLKOUT to TA, BI negation (when driven by the memory controller or PCMCIA interface) (MAX = 0.00 × B1 + 9.00)	2.50	9.00	2.50	9.00	2.50	9.00	2.5	9.00	ns
B13	CLKOUT to TS, BB High-Z (MIN = 0.25 × B1)	7.60	21.60	6.30	20.30	3.80	14.00	3.13	12.93	ns
B13a	CLKOUT to TA, BI High-Z (when driven by the memory controller or PCMCIA interface) (MIN = 0.00 × B1 + 2.5)	2.50	15.00	2.50	15.00	2.50	15.00	2.5	15.00	ns
B14	CLKOUT to TEA assertion (MAX = 0.00 × B1 + 9.00)	2.50	9.00	2.50	9.00	2.50	9.00	2.50	9.00	ns
B15	CLKOUT to TEA High-Z (MIN = 0.00 × B1 + 2.50)	2.50	15.00	2.50	15.00	2.50	15.00	2.50	15.00	ns
B16	TA, BI valid to CLKOUT (setup time) (MIN = 0.00 × B1 + 6.00)	6.00	—	6.00	—	6.00	—	6	—	ns
B16a	TEA, KR, RETRY, CR valid to CLKOUT (setup time) (MIN = 0.00 × B1 + 4.5)	4.50	—	4.50	—	4.50	—	4.50	—	ns
B16b	BB, BG, BR, valid to CLKOUT (setup time) ² (4MIN = 0.00 × B1 + 0.00)	4.00	—	4.00	—	4.00	—	4.00	—	ns
B17	CLKOUT to TA, TEA, BI, BB, BG, BR valid (hold time) (MIN = 0.00 × B1 + 1.00 ³)	1.00	—	1.00	—	2.00	—	2.00	—	ns
B17a	CLKOUT to KR, RETRY, CR valid (hold time) (MIN = 0.00 × B1 + 2.00)	2.00	—	2.00	—	2.00	—	2.00	—	ns

Table 10. Bus Operation Timings (continued)

Num	Characteristic	33 MHz		40 MHz		66 MHz		80 MHz		Unit
		Min	Max	Min	Max	Min	Max	Min	Max	
B18	D(0:31) valid to CLKOUT rising edge (setup time) ⁴ (MIN = 0.00 × B1 + 6.00)	6.00	—	6.00	—	6.00	—	6.00	—	ns
B19	CLKOUT rising edge to D(0:31) valid (hold time) ⁴ (MIN = 0.00 × B1 + 1.00 ⁵)	1.00	—	1.00	—	2.00	—	2.00	—	ns
B20	D(0:31) valid to CLKOUT falling edge (setup time) ⁶ (MIN = 0.00 × B1 + 4.00)	4.00	—	4.00	—	4.00	—	4.00	—	ns
B21	CLKOUT falling edge to D(0:31) valid (hold time) ⁶ (MIN = 0.00 × B1 + 2.00)	2.00	—	2.00	—	2.00	—	2.00	—	ns
B22	CLKOUT rising edge to \overline{CS} asserted GPCM ACS = 00 (MAX = 0.25 × B1 + 6.3)	7.60	13.80	6.30	12.50	3.80	10.00	3.13	9.43	ns
B22a	CLKOUT falling edge to \overline{CS} asserted GPCM ACS = 10, TRLX = 0 (MAX = 0.00 × B1 + 8.00)	—	8.00	—	8.00	—	8.00	—	8.00	ns
B22b	CLKOUT falling edge to \overline{CS} asserted GPCM ACS = 11, TRLX = 0, EBDF = 0 (MAX = 0.25 × B1 + 6.3)	7.60	13.80	6.30	12.50	3.80	10.00	3.13	9.43	ns
B22c	CLKOUT falling edge to \overline{CS} asserted GPCM ACS = 11, TRLX = 0, EBDF = 1 (MAX = 0.375 × B1 + 6.6)	10.90	18.00	10.90	16.00	5.20	12.30	4.69	10.93	ns
B23	CLKOUT rising edge to \overline{CS} negated GPCM read access, GPCM write access ACS = 00, TRLX = 0 & CSNT = 0 (MAX = 0.00 × B1 + 8.00)	2.00	8.00	2.00	8.00	2.00	8.00	2.00	8.00	ns
B24	A(0:31) and BADDR(28:30) to \overline{CS} asserted GPCM ACS = 10, TRLX = 0 (MIN = 0.25 × B1 – 2.00)	5.60	—	4.30	—	1.80	—	1.13	—	ns
B24a	A(0:31) and BADDR(28:30) to \overline{CS} asserted GPCM ACS = 11 TRLX = 0 (MIN = 0.50 × B1 – 2.00)	13.20	—	10.50	—	5.60	—	4.25	—	ns
B25	CLKOUT rising edge to \overline{OE} , $\overline{WE}(0:3)/BS_B[0:3]$ asserted (MAX = 0.00 × B1 + 9.00)	—	9.00	—	9.00	—	9.00	—	9.00	ns
B26	CLKOUT rising edge to \overline{OE} negated (MAX = 0.00 × B1 + 9.00)	2.00	9.00	2.00	9.00	2.00	9.00	2.00	9.00	ns
B27	A(0:31) and BADDR(28:30) to \overline{CS} asserted GPCM ACS = 10, TRLX = 1 (MIN = 1.25 × B1 – 2.00)	35.90	—	29.30	—	16.90	—	13.60	—	ns
B27a	A(0:31) and BADDR(28:30) to \overline{CS} asserted GPCM ACS = 11, TRLX = 1 (MIN = 1.50 × B1 – 2.00)	43.50	—	35.50	—	20.70	—	16.75	—	ns

Table 10. Bus Operation Timings (continued)

Num	Characteristic	33 MHz		40 MHz		66 MHz		80 MHz		Unit
		Min	Max	Min	Max	Min	Max	Min	Max	
B28	CLKOUT rising edge to $\overline{WE}(0:3)/BS_B[0:3]$ negated GPCM write access CSNT = 0 (MAX = $0.00 \times B1 + 9.00$)	—	9.00	—	9.00	—	9.00	—	9.00	ns
B28a	CLKOUT falling edge to $\overline{WE}(0:3)/BS_B[0:3]$ negated GPCM write access TRLX = 0, CSNT = 1, EBDF = 0 (MAX = $0.25 \times B1 + 6.80$)	7.60	14.30	6.30	13.00	3.80	10.50	3.13	9.93	ns
B28b	CLKOUT falling edge to \overline{CS} negated GPCM write access TRLX = 0, CSNT = 1 ACS = 10 or ACS = 11, EBDF = 0 (MAX = $0.25 \times B1 + 6.80$)	—	14.30	—	13.00	—	10.50	—	9.93	ns
B28c	CLKOUT falling edge to $\overline{WE}(0:3)/BS_B[0:3]$ negated GPCM write access TRLX = 0, CSNT = 1 write access TRLX = 0, CSNT = 1, EBDF = 1 (MAX = $0.375 \times B1 + 6.6$)	10.90	18.00	10.90	18.00	5.20	12.30	4.69	11.29	ns
B28d	CLKOUT falling edge to \overline{CS} negated GPCM write access TRLX = 0, CSNT = 1, ACS = 10, or ACS = 11, EBDF = 1 (MAX = $0.375 \times B1 + 6.6$)	—	18.00	—	18.00	—	12.30	—	11.30	ns
B29	$\overline{WE}(0:3)/BS_B[0:3]$ negated to D(0:31) High-Z GPCM write access, CSNT = 0, EBDF = 0 (MIN = $0.25 \times B1 - 2.00$)	5.60	—	4.30	—	1.80	—	1.13	—	ns
B29a	$\overline{WE}(0:3)/BS_B[0:3]$ negated to D(0:31) High-Z GPCM write access, TRLX = 0, CSNT = 1, EBDF = 0 (MIN = $0.50 \times B1 - 2.00$)	13.20	—	10.50	—	5.60	—	4.25	—	ns
B29b	\overline{CS} negated to D(0:31) High-Z GPCM write access, ACS = 00, TRLX = 0 & CSNT = 0 (MIN = $0.25 \times B1 - 2.00$)	5.60	—	4.30	—	1.80	—	1.13	—	ns
B29c	\overline{CS} negated to D(0:31) High-Z GPCM write access, TRLX = 0, CSNT = 1, ACS = 10, or ACS = 11 EBDF = 0 (MIN = $0.50 \times B1 - 2.00$)	13.20	—	10.50	—	5.60	—	4.25	—	ns
B29d	$\overline{WE}(0:3)/BS_B[0:3]$ negated to D(0:31) High-Z GPCM write access, TRLX = 1, CSNT = 1, EBDF = 0 (MIN = $1.50 \times B1 - 2.00$)	43.50	—	35.50	—	20.70	—	16.75	—	ns
B29e	\overline{CS} negated to D(0:31) High-Z GPCM write access, TRLX = 1, CSNT = 1, ACS = 10, or ACS = 11, EBDF = 0 (MIN = $1.50 \times B1 - 2.00$)	43.50	—	35.50	—	20.70	—	16.75	—	ns

Table 10. Bus Operation Timings (continued)

Num	Characteristic	33 MHz		40 MHz		66 MHz		80 MHz		Unit
		Min	Max	Min	Max	Min	Max	Min	Max	
B29f	$\overline{WE}(0:3)/BS_B[0:3]$ negated to D(0:31) High-Z GPCM write access, TRLX = 0, CSNT = 1, EBDF = 1 (MIN = $0.375 \times B1 - 6.30$)	5.00	—	3.00	—	0.00	—	0.00	—	ns
B29g	\overline{CS} negated to D(0:31) High-Z GPCM write access, TRLX = 0, CSNT = 1 ACS = 10 or ACS = 11, EBDF = 1 (MIN = $0.375 \times B1 - 6.30$)	5.00	—	3.00	—	0.00	—	0.00	—	ns
B29h	$\overline{WE}(0:3)/BS_B[0:3]$ negated to D(0:31) High-Z GPCM write access, TRLX = 1, CSNT = 1, EBDF = 1 (MIN = $0.375 \times B1 - 3.30$)	38.40	—	31.10	—	17.50	—	13.85	—	ns
B29i	\overline{CS} negated to D(0:31) (0:3) High-Z GPCM write access, TRLX = 1, CSNT = 1, ACS = 10 or ACS = 11, EBDF = 1 (MIN = $0.375 \times B1 - 3.30$)	38.40	—	31.10	—	17.50	—	13.85	—	ns
B30	\overline{CS} , $\overline{WE}(0:3)/BS_B[0:3]$ negated to A(0:31), BADDR(28:30) invalid GPCM write access ⁷ (MIN = $0.25 \times B1 - 2.00$)	5.60	—	4.30	—	1.80	—	1.13	—	ns
B30a	$\overline{WE}(0:3)/BS_B[0:3]$ negated to A(0:31), BADDR(28:30) invalid GPCM, write access, TRLX = 0, CSNT = 1, \overline{CS} negated to A(0:31) invalid GPCM write access TRLX = 0, CSNT = 1 ACS = 10, or ACS = 11, EBDF = 0 (MIN = $0.50 \times B1 - 2.00$)	13.20	—	10.50	—	5.60	—	4.25	—	ns
B30b	$\overline{WE}(0:3)/BS_B[0:3]$ negated to A(0:31) Invalid GPCM BADDR(28:30) invalid GPCM write access, TRLX = 1, CSNT = 1. \overline{CS} negated to A(0:31) invalid GPCM write access TRLX = 1, CSNT = 1, ACS = 10, or ACS = 11 EBDF = 0 (MIN = $1.50 \times B1 - 2.00$)	43.50	—	35.50	—	20.70	—	16.75	—	ns
B30c	$\overline{WE}(0:3)/BS_B[0:3]$ negated to A(0:31), BADDR(28:30) invalid GPCM write access, TRLX = 0, CSNT = 1. \overline{CS} negated to A(0:31) invalid GPCM write access, TRLX = 0, CSNT = 1 ACS = 10, ACS = 11, EBDF = 1 (MIN = $0.375 \times B1 - 3.00$)	8.40	—	6.40	—	2.70	—	1.70	—	ns
B30d	$\overline{WE}(0:3)/BS_B[0:3]$ negated to A(0:31), BADDR(28:30) invalid GPCM write access TRLX = 1, CSNT = 1, \overline{CS} negated to A(0:31) invalid GPCM write access TRLX = 1, CSNT = 1, ACS = 10 or 11, EBDF = 1	38.67	—	31.38	—	17.83	—	14.19	—	ns

Table 10. Bus Operation Timings (continued)

Num	Characteristic	33 MHz		40 MHz		66 MHz		80 MHz		Unit
		Min	Max	Min	Max	Min	Max	Min	Max	
B31	CLKOUT falling edge to \overline{CS} valid, as requested by control bit CST4 in the corresponding word in the UPM (MAX = $0.00 \times B1 + 6.00$)	1.50	6.00	1.50	6.00	1.50	6.00	1.50	6.00	ns
B31a	CLKOUT falling edge to \overline{CS} valid, as requested by control bit CST1 in the corresponding word in the UPM (MAX = $0.25 \times B1 + 6.80$)	7.60	14.30	6.30	13.00	3.80	10.50	3.13	10.00	ns
B31b	CLKOUT rising edge to \overline{CS} valid, as requested by control bit CST2 in the corresponding word in the UPM (MAX = $0.00 \times B1 + 8.00$)	1.50	8.00	1.50	8.00	1.50	8.00	1.50	8.00	ns
B31c	CLKOUT rising edge to \overline{CS} valid, as requested by control bit CST3 in the corresponding word in the UPM (MAX = $0.25 \times B1 + 6.30$)	7.60	13.80	6.30	12.50	3.80	10.00	3.13	9.40	ns
B31d	CLKOUT falling edge to \overline{CS} valid, as requested by control bit CST1 in the corresponding word in the UPM EBDF = 1 (MAX = $0.375 \times B1 + 6.6$)	13.30	18.00	11.30	16.00	7.60	12.30	4.69	11.30	ns
B32	CLKOUT falling edge to \overline{BS} valid, as requested by control bit BST4 in the corresponding word in the UPM (MAX = $0.00 \times B1 + 6.00$)	1.50	6.00	1.50	6.00	1.50	6.00	1.50	6.00	ns
B32a	CLKOUT falling edge to \overline{BS} valid, as requested by control bit BST1 in the corresponding word in the UPM, EBDF = 0 (MAX = $0.25 \times B1 + 6.80$)	7.60	14.30	6.30	13.00	3.80	10.50	3.13	10.00	ns
B32b	CLKOUT rising edge to \overline{BS} valid, as requested by control bit BST2 in the corresponding word in the UPM (MAX = $0.00 \times B1 + 8.00$)	1.50	8.00	1.50	8.00	1.50	8.00	1.50	8.00	ns
B32c	CLKOUT rising edge to \overline{BS} valid, as requested by control bit BST3 in the corresponding word in the UPM (MAX = $0.25 \times B1 + 6.80$)	7.60	14.30	6.30	13.00	3.80	10.50	3.13	10.00	ns
B32d	CLKOUT falling edge to \overline{BS} valid, as requested by control bit BST1 in the corresponding word in the UPM, EBDF = 1 (MAX = $0.375 \times B1 + 6.60$)	13.30	18.00	11.30	16.00	7.60	12.30	4.49	11.30	ns
B33	CLKOUT falling edge to \overline{GPL} valid, as requested by control bit GxT4 in the corresponding word in the UPM (MAX = $0.00 \times B1 + 6.00$)	1.50	6.00	1.50	6.00	1.50	6.00	1.50	6.00	ns

Table 10. Bus Operation Timings (continued)

Num	Characteristic	33 MHz		40 MHz		66 MHz		80 MHz		Unit
		Min	Max	Min	Max	Min	Max	Min	Max	
B33a	CLKOUT rising edge to \overline{GPL} valid, as requested by control bit GxT3 in the corresponding word in the UPM (MAX = $0.25 \times B1 + 6.80$)	7.60	14.30	6.30	13.00	3.80	10.50	3.13	10.00	ns
B34	A(0:31), BADDR(28:30), and D(0:31) to \overline{CS} valid, as requested by control bit CST4 in the corresponding word in the UPM (MIN = $0.25 \times B1 - 2.00$)	5.60	—	4.30	—	1.80	—	1.13	—	ns
B34a	A(0:31), BADDR(28:30), and D(0:31) to \overline{CS} valid, as requested by control bit CST1 in the corresponding word in the UPM (MIN = $0.50 \times B1 - 2.00$)	13.20	—	10.50	—	5.60	—	4.25	—	ns
B34b	A(0:31), BADDR(28:30), and D(0:31) to \overline{CS} valid, as requested by control bit CST2 in the corresponding word in UPM (MIN = $0.75 \times B1 - 2.00$)	20.70	—	16.70	—	9.40	—	6.80	—	ns
B35	A(0:31), BADDR(28:30) to \overline{CS} valid, as requested by control bit BST4 in the corresponding word in the UPM (MIN = $0.25 \times B1 - 2.00$)	5.60	—	4.30	—	1.80	—	1.13	—	ns
B35a	A(0:31), BADDR(28:30), and D(0:31) to \overline{BS} valid, as requested by BST1 in the corresponding word in the UPM (MIN = $0.50 \times B1 - 2.00$)	13.20	—	10.50	—	5.60	—	4.25	—	ns
B35b	A(0:31), BADDR(28:30), and D(0:31) to \overline{BS} valid, as requested by control bit BST2 in the corresponding word in the UPM (MIN = $0.75 \times B1 - 2.00$)	20.70	—	16.70	—	9.40	—	7.40	—	ns
B36	A(0:31), BADDR(28:30), and D(0:31) to GPL valid, as requested by control bit GxT4 in the corresponding word in the UPM (MIN = $0.25 \times B1 - 2.00$)	5.60	—	4.30	—	1.80	—	1.13	—	ns
B37	UPWAIT valid to CLKOUT falling edge ⁸ (MIN = $0.00 \times B1 + 6.00$)	6.00	—	6.00	—	6.00	—	6.00	—	ns
B38	CLKOUT falling edge to UPWAIT valid ⁸ (MIN = $0.00 \times B1 + 1.00$)	1.00	—	1.00	—	1.00	—	1.00	—	ns
B39	\overline{AS} valid to CLKOUT rising edge ⁹ (MIN = $0.00 \times B1 + 7.00$)	7.00	—	7.00	—	7.00	—	7.00	—	ns
B40	A(0:31), TSIZE(0:1), RD/ \overline{WR} , \overline{BURST} , valid to CLKOUT rising edge (MIN = $0.00 \times B1 + 7.00$)	7.00	—	7.00	—	7.00	—	7.00	—	ns
B41	\overline{TS} valid to CLKOUT rising edge (setup time) (MIN = $0.00 \times B1 + 7.00$)	7.00	—	7.00	—	7.00	—	7.00	—	ns

Table 10. Bus Operation Timings (continued)

Num	Characteristic	33 MHz		40 MHz		66 MHz		80 MHz		Unit
		Min	Max	Min	Max	Min	Max	Min	Max	
B42	CLKOUT rising edge to \overline{TS} valid (hold time) (MIN = $0.00 \times B1 + 2.00$)	2.00	—	2.00	—	2.00	—	2.00	—	ns
B43	\overline{AS} negation to memory controller signals negation (MAX = TBD)	—	TBD	—	TBD	—	TBD	—	TBD	ns

¹ For part speeds above 50 MHz, use 9.80 ns for B11a.

² The timing required for \overline{BR} input is relevant when the MPC875/870 is selected to work with the internal bus arbiter. The timing for \overline{BG} input is relevant when the MPC875/870 is selected to work with the external bus arbiter.

³ For part speeds above 50 MHz, use 2 ns for B17.

⁴ The D(0:31) input timings B18 and B19 refer to the rising edge of the CLKOUT in which the \overline{TA} input signal is asserted.

⁵ For part speeds above 50 MHz, use 2 ns for B19.

⁶ The D(0:31) input timings B20 and B21 refer to the falling edge of the CLKOUT. This timing is valid only for read accesses controlled by chip-selects under control of the user-programmable machine (UPM) in the memory controller, for data beats where DLT3 = 1 in the RAM words. (This is only the case where data is latched on the falling edge of CLKOUT.)

⁷ The timing B30 refers to \overline{CS} when ACS = 00 and to $\overline{WE}(0:3)$ when CSNT = 0.

⁸ The signal UPWAIT is considered asynchronous to the CLKOUT and synchronized internally. The timings specified in B37 and B38 are specified to enable the freeze of the UPM output signals as described in Figure 19.

⁹ The \overline{AS} signal is considered asynchronous to the CLKOUT. The timing B39 is specified in order to allow the behavior specified in Figure 22.

Bus Signal Timing

Figure 4 provides the control timing diagram.

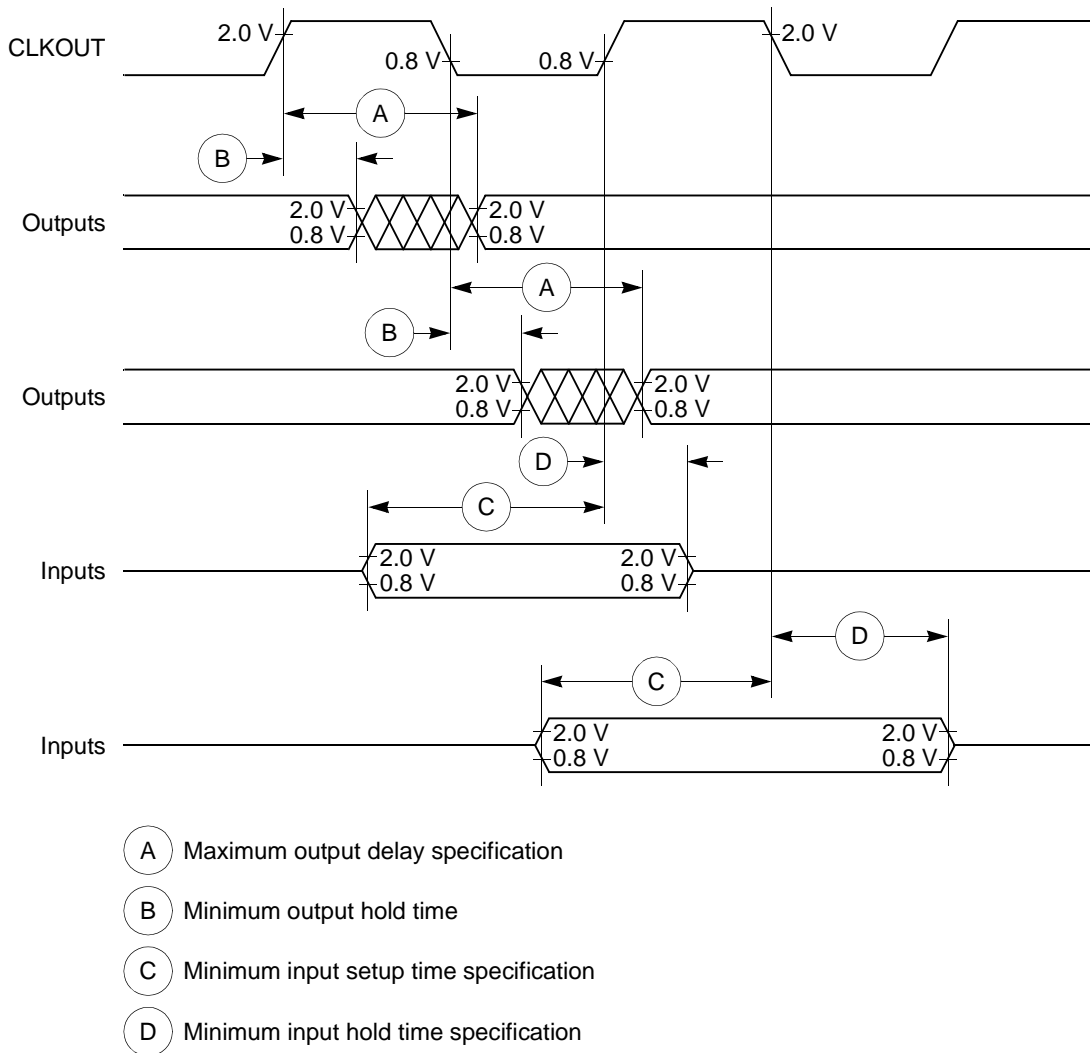

Figure 4. Control Timing

Figure 5 provides the timing for the external clock.

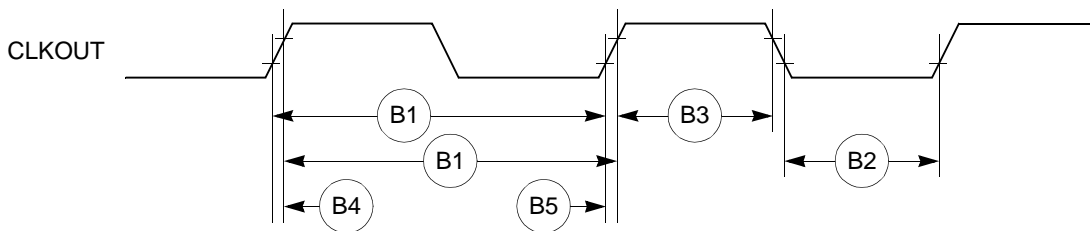

Figure 5. External Clock Timing

Bus Signal Timing

Figure 6 provides the timing for the synchronous output signals.

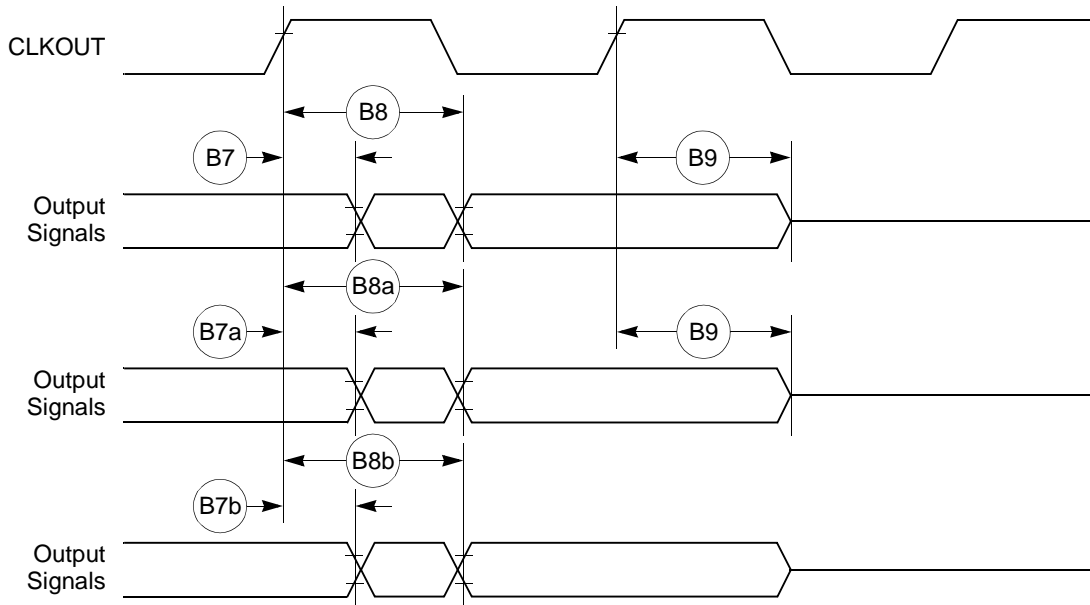

Figure 6. Synchronous Output Signals Timing

Figure 7 provides the timing for the synchronous active pull-up and open-drain output signals.

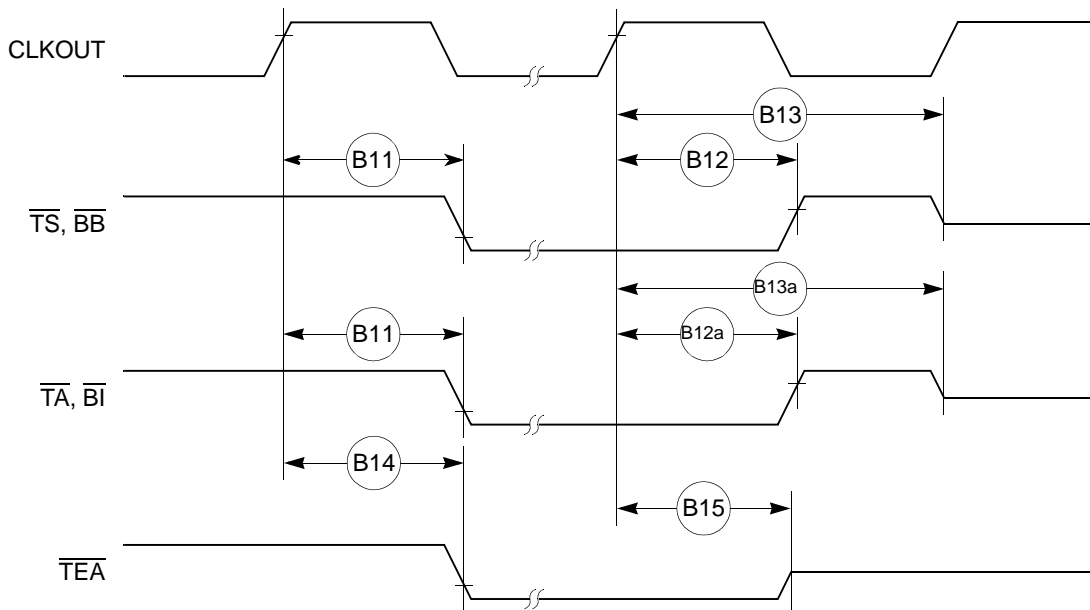

Figure 7. Synchronous Active Pull-Up Resistor and Open-Drain Outputs Signals Timing

Bus Signal Timing

Figure 8 provides the timing for the synchronous input signals.

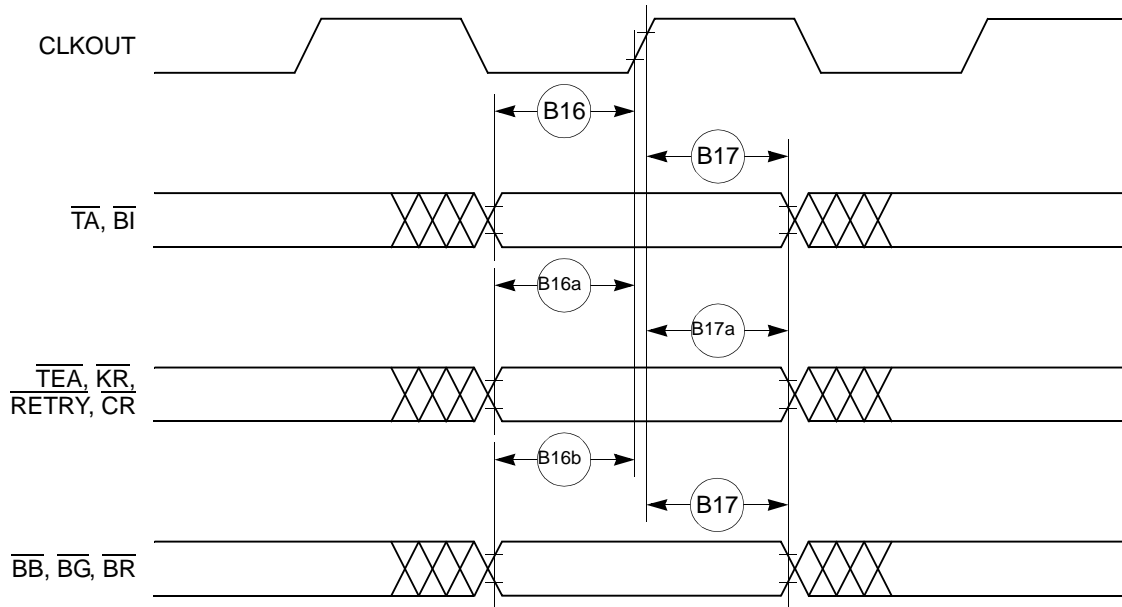

Figure 8. Synchronous Input Signals Timing

Figure 9 provides normal case timing for input data. It also applies to normal read accesses under the control of the user-programmable machine (UPM) in the memory controller.

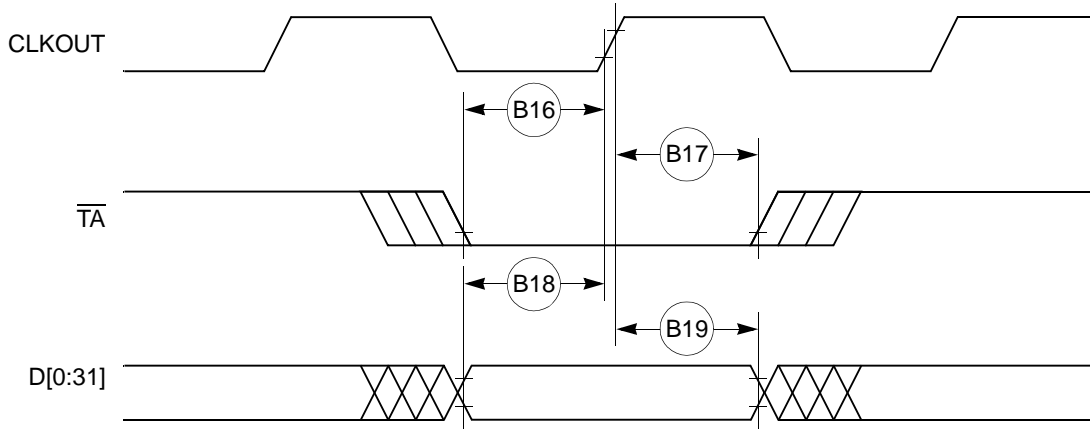

Figure 9. Input Data Timing in Normal Case

Bus Signal Timing

Figure 10 provides the timing for the input data controlled by the UPM for data beats where $DLT3 = 1$ in the UPM RAM words. (This is only the case where data is latched on the falling edge of CLKOUT.)

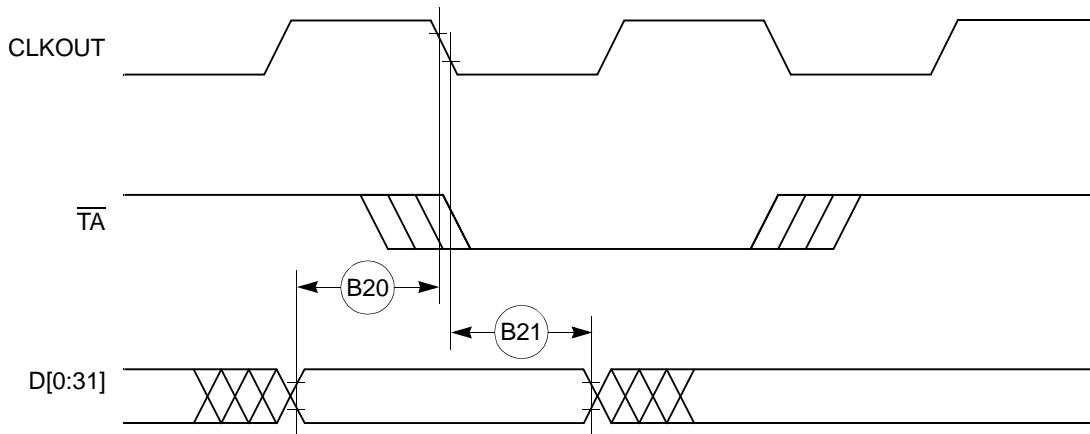

Figure 10. Input Data Timing when Controlled by UPM in the Memory Controller and $DLT3 = 1$

Figure 11 through Figure 14 provide the timing for the external bus read controlled by various GPCM factors.

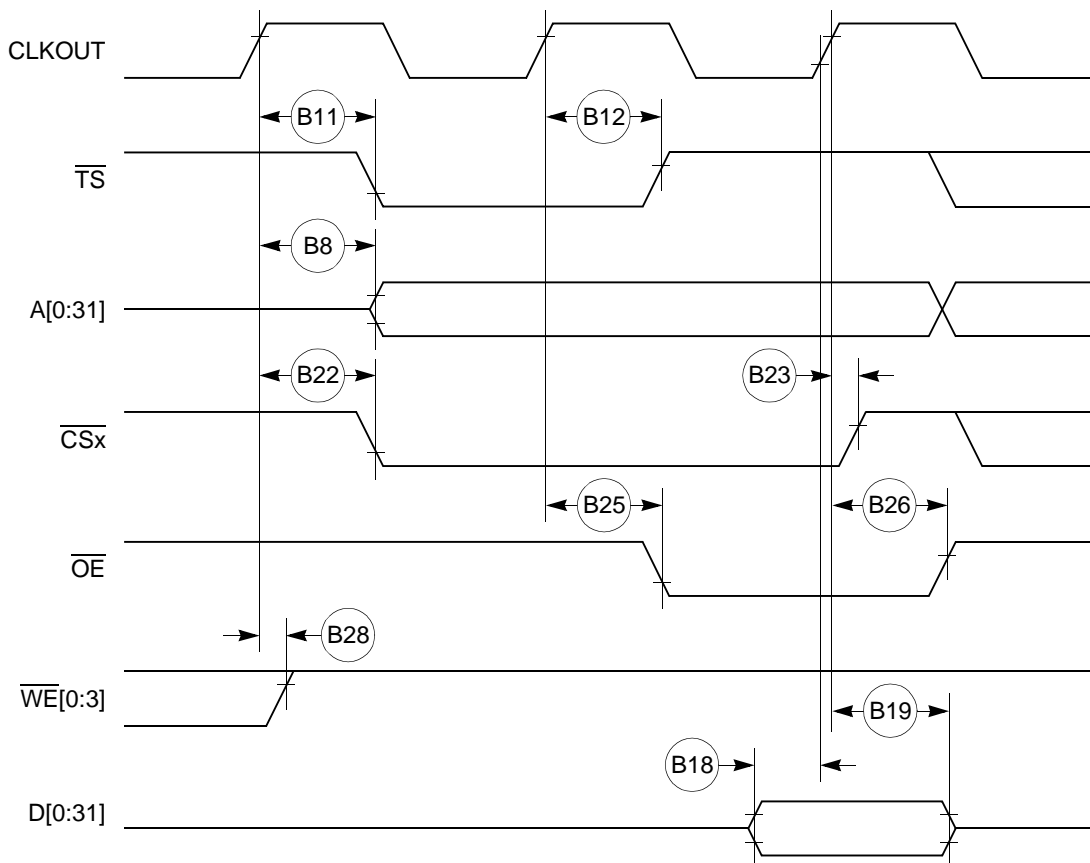

Figure 11. External Bus Read Timing (GPCM Controlled— $ACS = 00$)

Bus Signal Timing

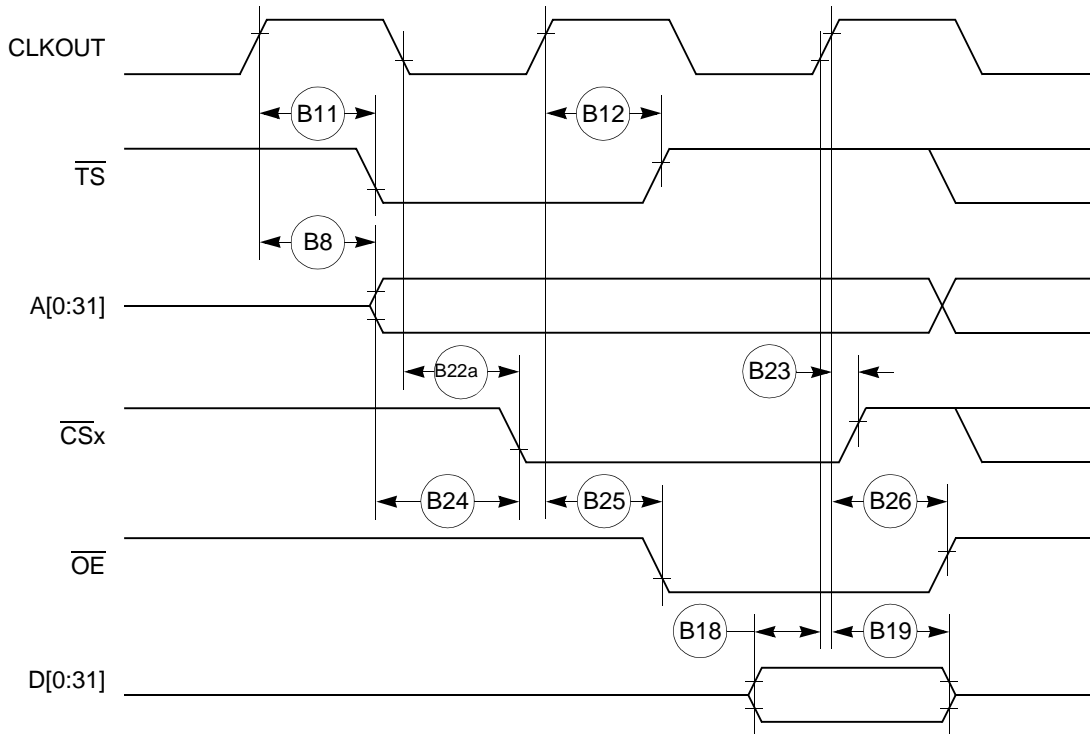

Figure 12. External Bus Read Timing (GPCM Controlled—TRLX = 0, ACS = 10)

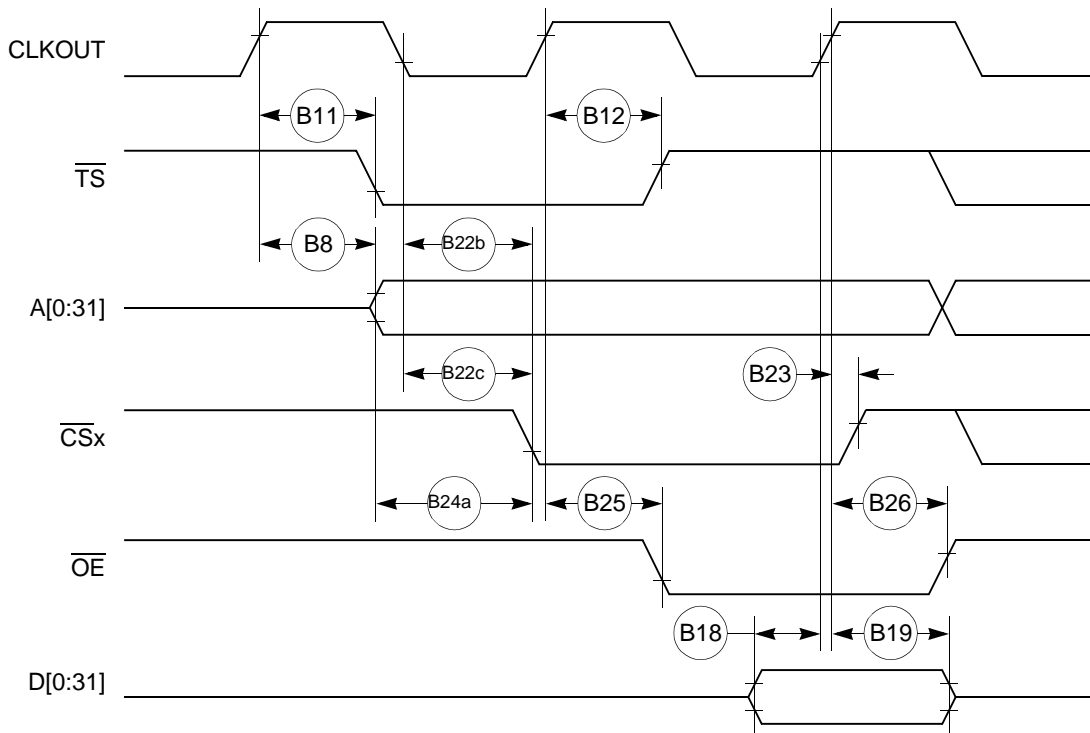

Figure 13. External Bus Read Timing (GPCM Controlled—TRLX = 0, ACS = 11)

Bus Signal Timing

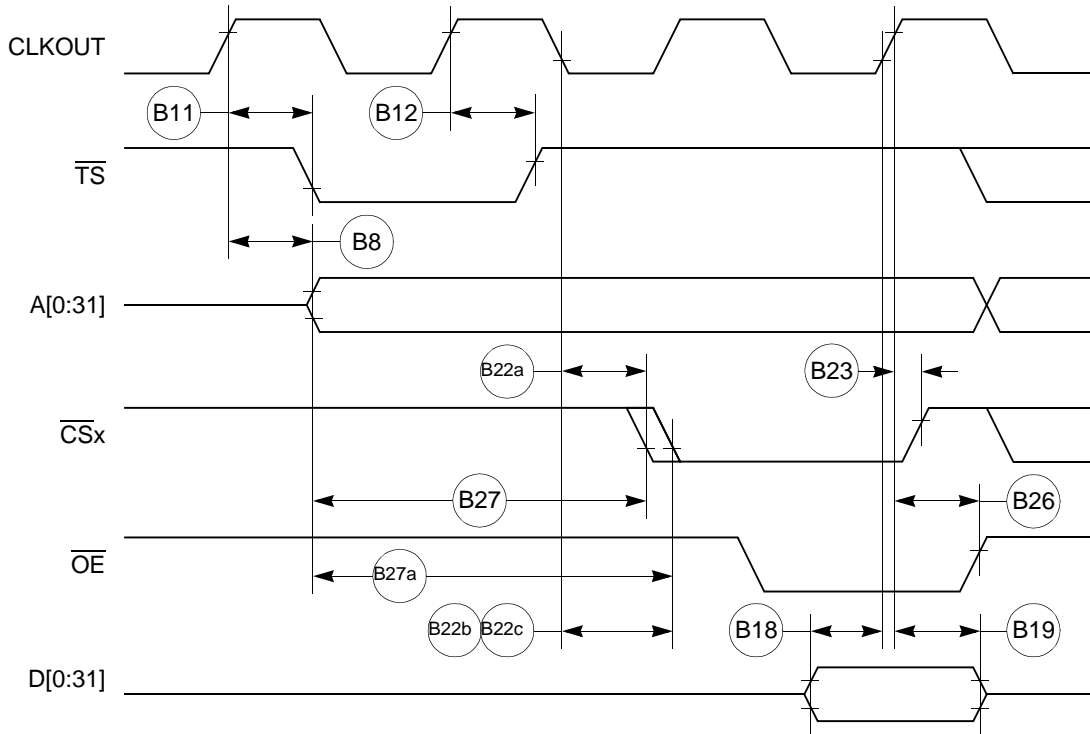

Figure 14. External Bus Read Timing (GPCM Controlled—TRLX = 1, ACS = 10, ACS = 11)

Bus Signal Timing

Figure 15 through Figure 17 provide the timing for the external bus write controlled by various GPCM factors.

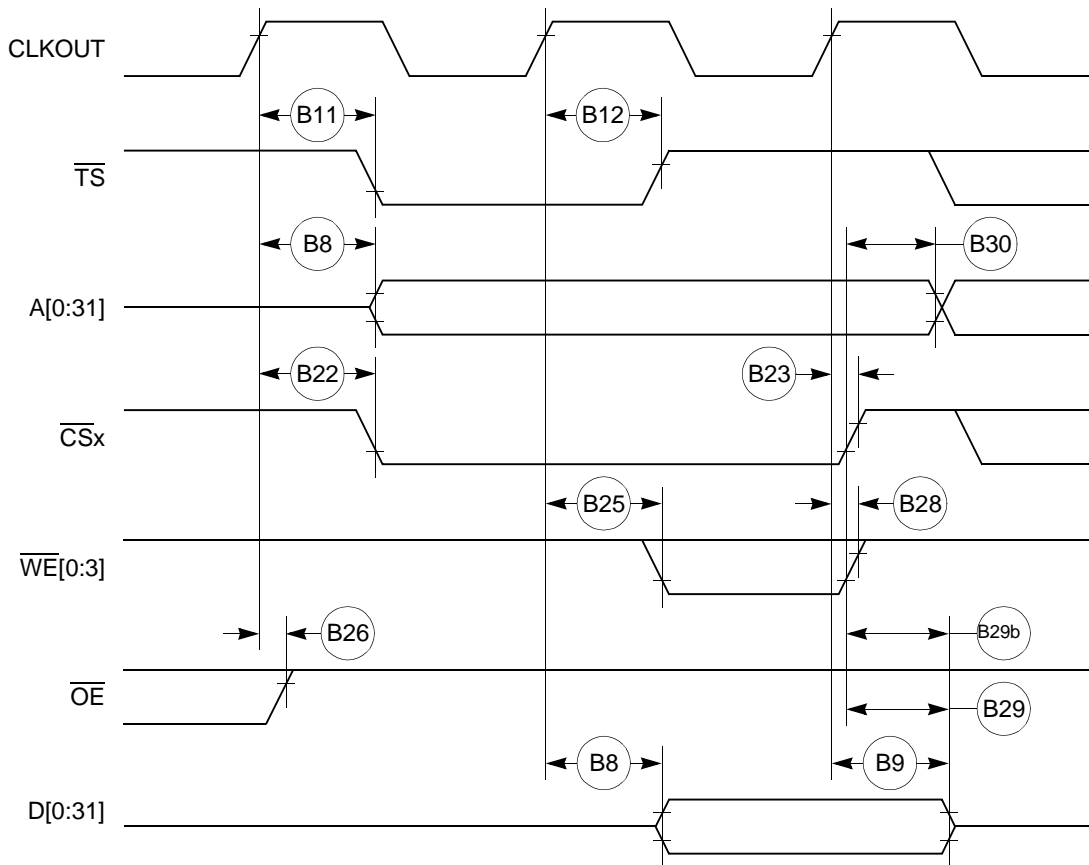

Figure 15. External Bus Write Timing (GPCM Controlled—TRLX = 0, CSNT = 0)

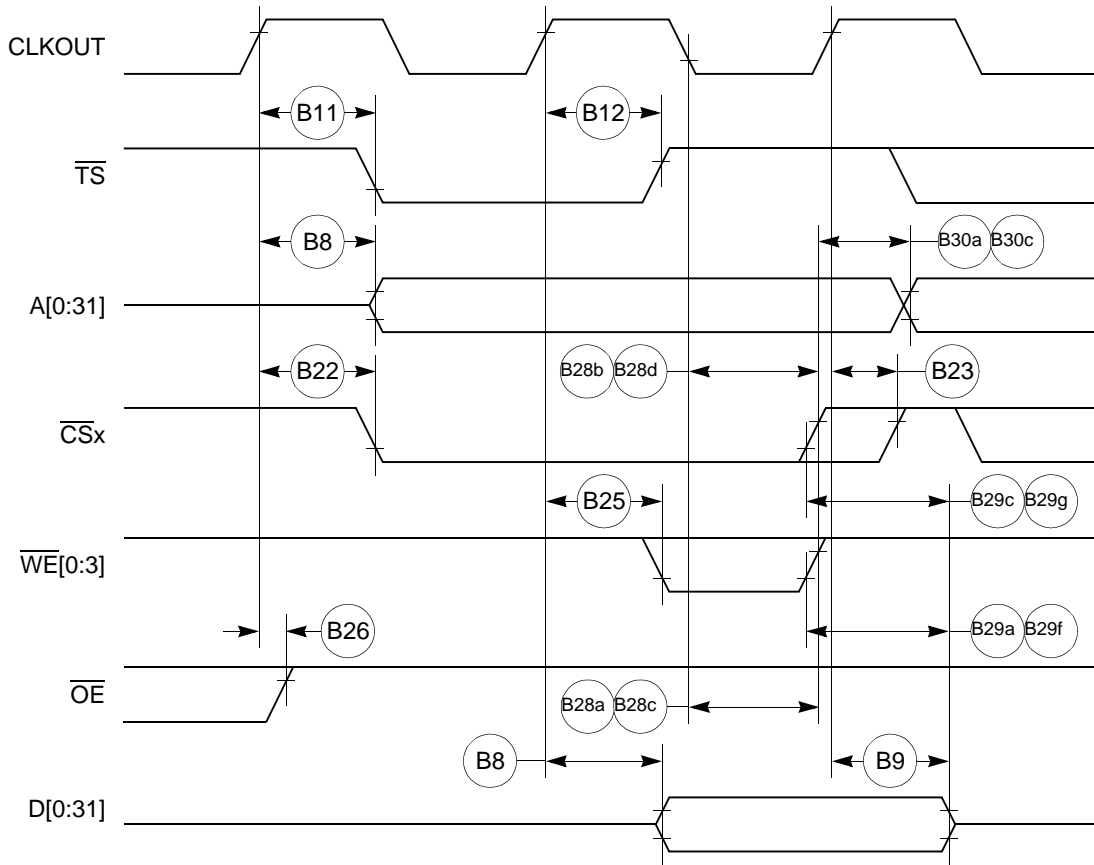

Figure 16. External Bus Write Timing (GPCM Controlled—TRLX = 0, CSNT = 1)

Bus Signal Timing

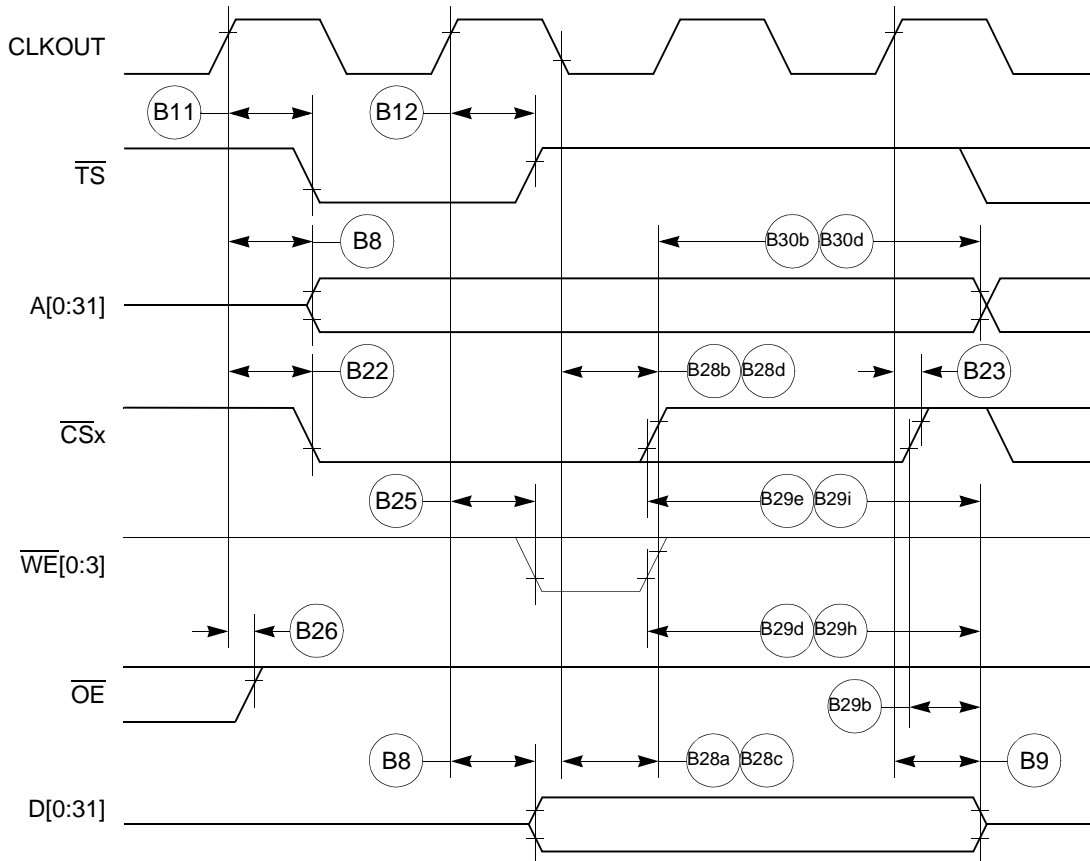

Figure 17. External Bus Write Timing (GPCM Controlled—TRLX = 1, CSNT = 1)

Bus Signal Timing

Figure 18 provides the timing for the external bus controlled by the UPM.

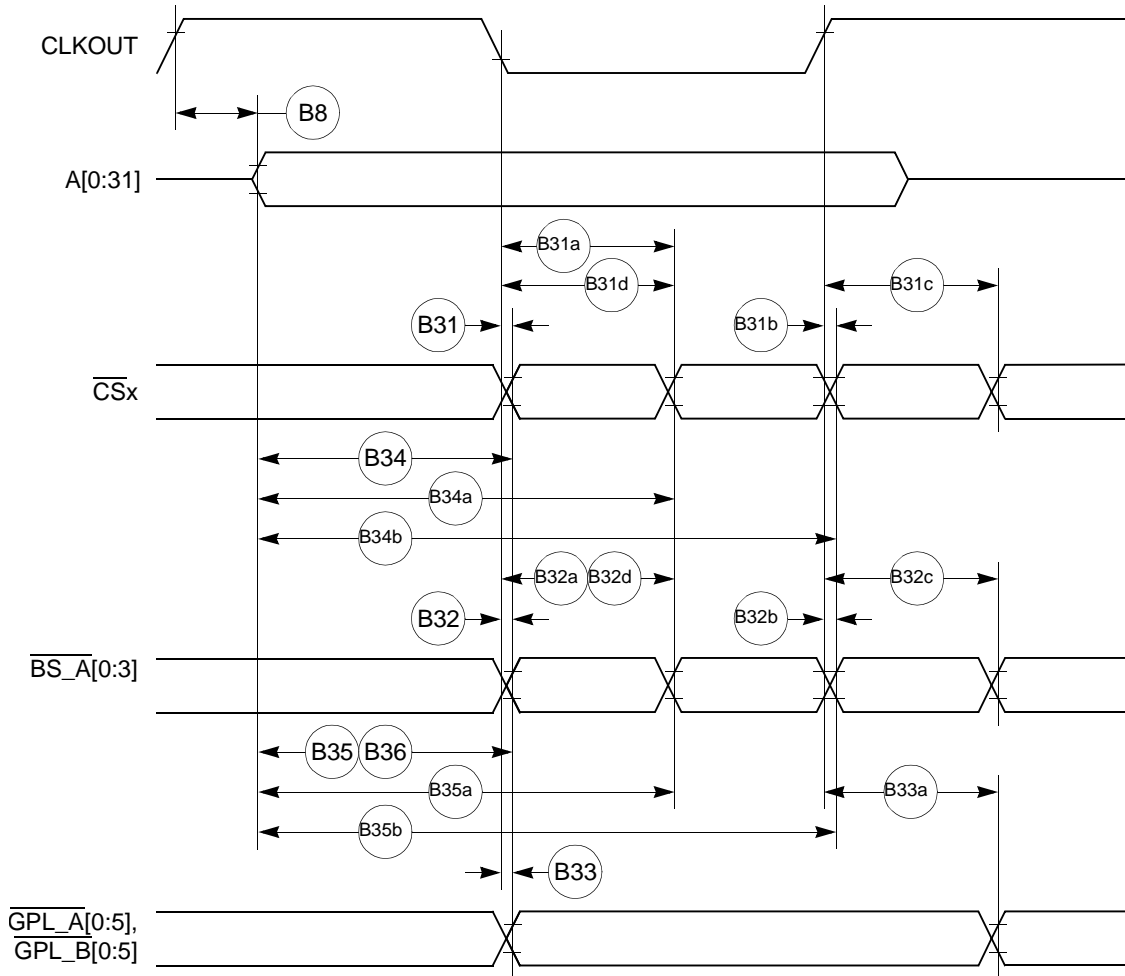

Figure 18. External Bus Timing (UPM Controlled Signals)

Bus Signal Timing

Figure 19 provides the timing for the asynchronous asserted UPWAIT signal controlled by the UPM.

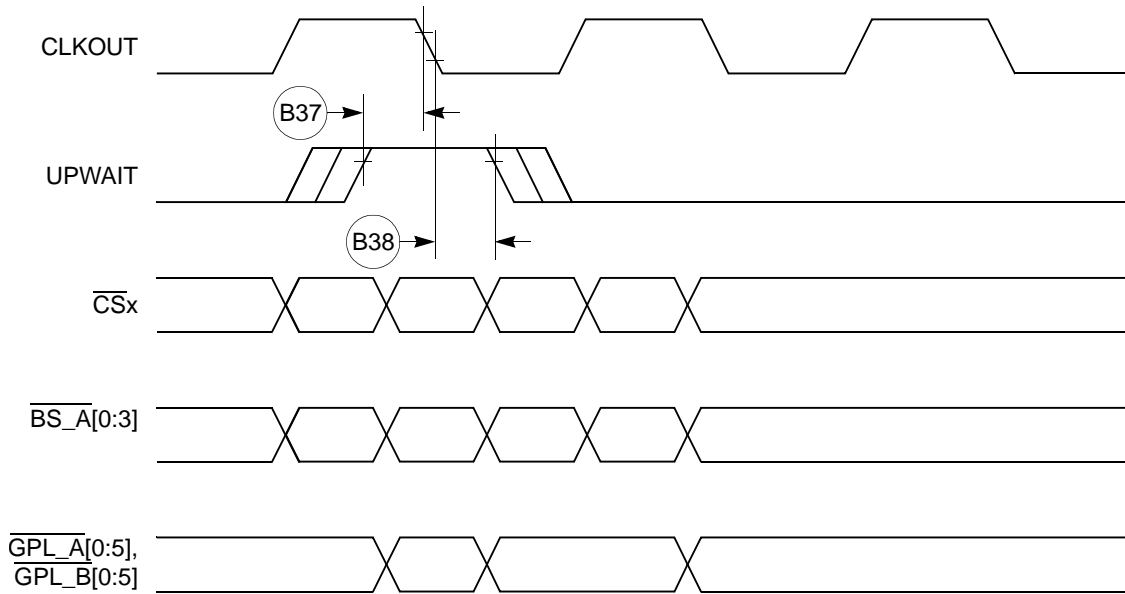

Figure 19. Asynchronous UPWAIT Asserted Detection in UPM Handled Cycles Timing

Figure 20 provides the timing for the asynchronous negated UPWAIT signal controlled by the UPM.

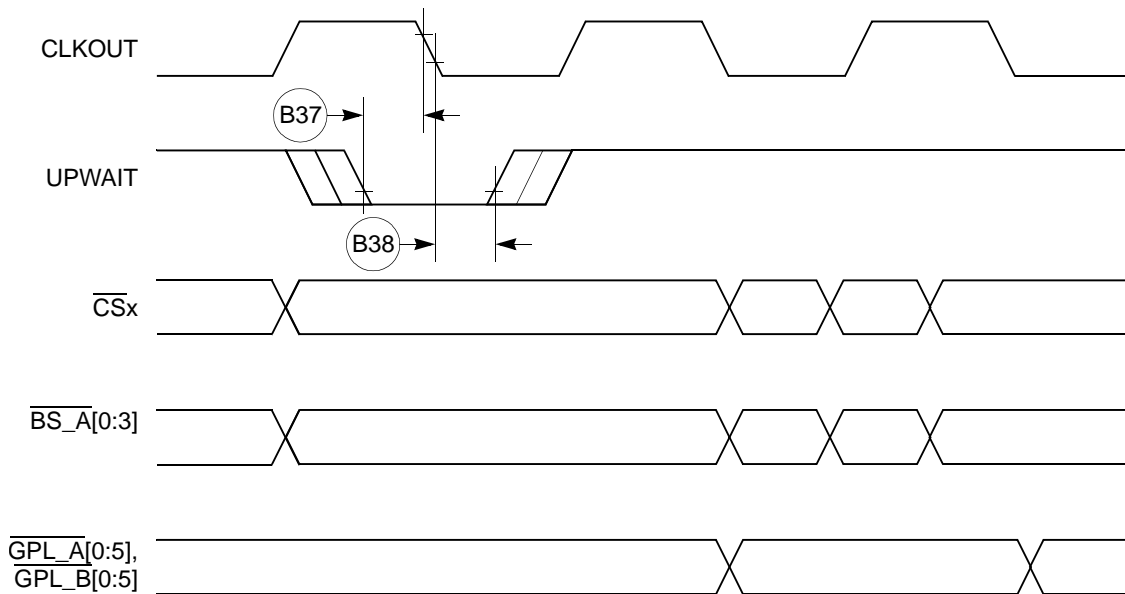

Figure 20. Asynchronous UPWAIT Negated Detection in UPM Handled Cycles Timing

Bus Signal Timing

Figure 21 provides the timing for the synchronous external master access controlled by the GPCM.

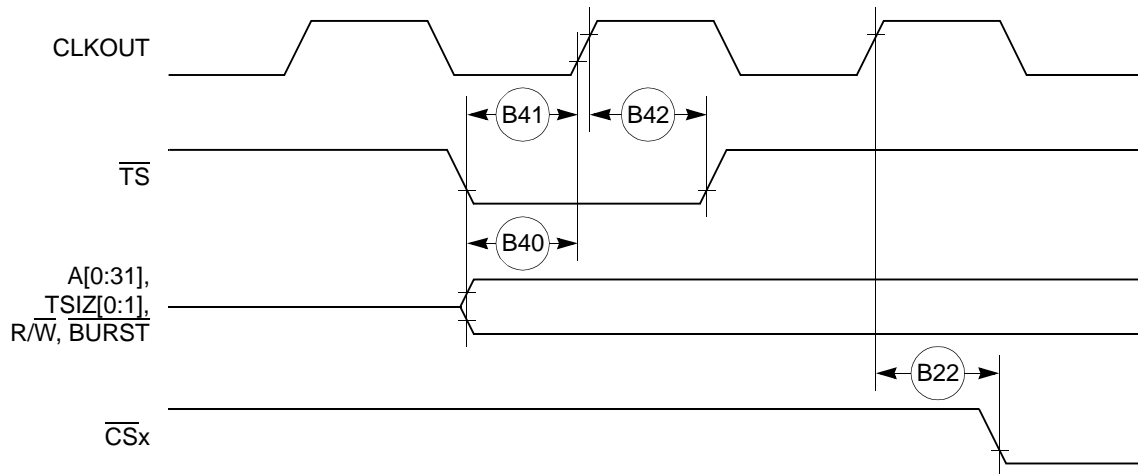

Figure 21. Synchronous External Master Access Timing (GPCM Handled ACS = 00)

Figure 22 provides the timing for the asynchronous external master memory access controlled by the GPCM.

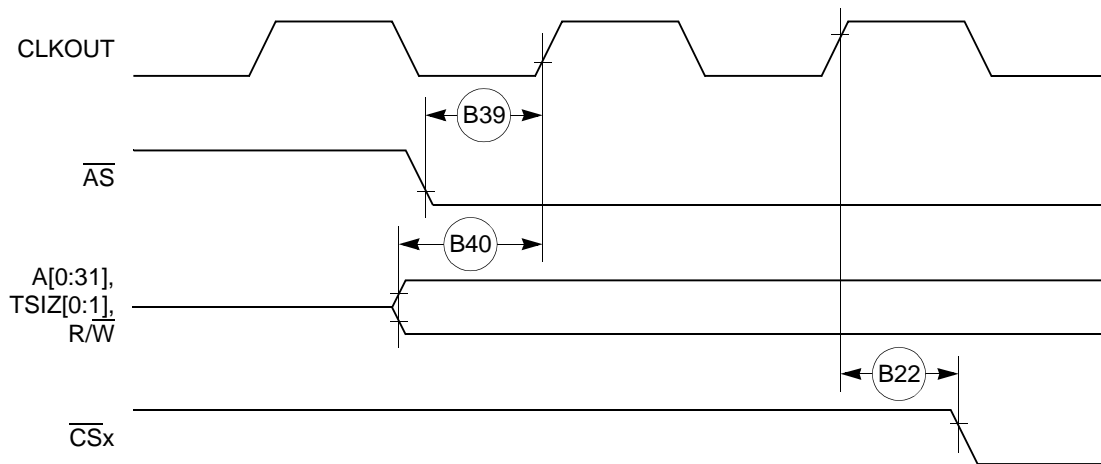

Figure 22. Asynchronous External Master Memory Access Timing (GPCM Controlled—ACS = 00)

Figure 23 provides the timing for the asynchronous external master control signals negation.

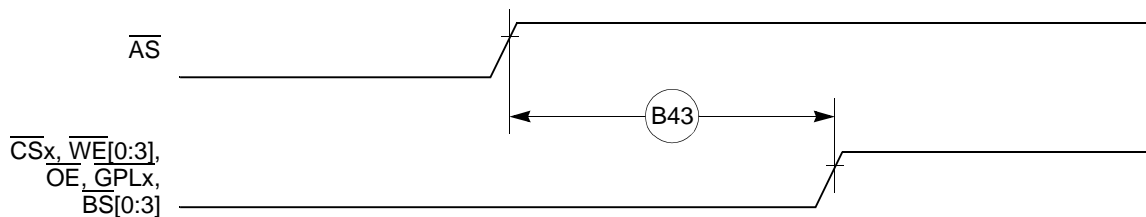

Figure 23. Asynchronous External Master—Control Signals Negation Timing

Table 11 provides the interrupt timing for the MPC875/870.

Table 11. Interrupt Timing

Num	Characteristic ¹	All Frequencies		Unit
		Min	Max	
I39	$\overline{\text{IRQ}}_x$ valid to CLKOUT rising edge (setup time)	6.00		ns
I40	$\overline{\text{IRQ}}_x$ hold time after CLKOUT	2.00		ns
I41	$\overline{\text{IRQ}}_x$ pulse width low	3.00		ns
I42	$\overline{\text{IRQ}}_x$ pulse width high	3.00		ns
I43	$\overline{\text{IRQ}}_x$ edge-to-edge time	4xT _{CLKOUT}		—

¹ The I39 and I40 timings describe the testing conditions under which the $\overline{\text{IRQ}}$ lines are tested when being defined as level sensitive. The $\overline{\text{IRQ}}$ lines are synchronized internally and do not have to be asserted or negated with reference to the CLKOUT.

The I41, I42, and I43 timings are specified to allow correct functioning of the $\overline{\text{IRQ}}$ lines detection circuitry and have no direct relation with the total system interrupt latency that the MPC875/870 is able to support.

Figure 24 provides the interrupt detection timing for the external level-sensitive lines.

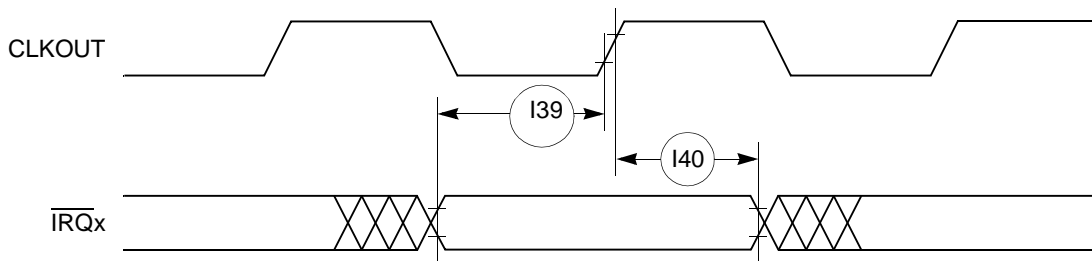

Figure 24. Interrupt Detection Timing for External Level Sensitive Lines

Figure 25 provides the interrupt detection timing for the external edge-sensitive lines.

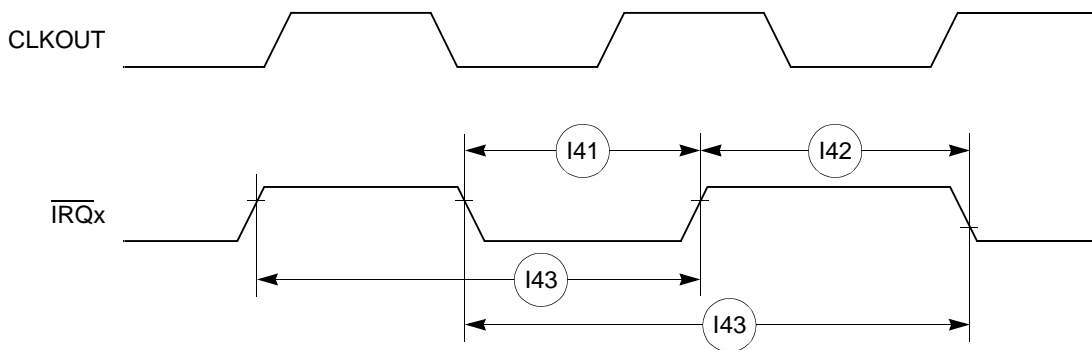

Figure 25. Interrupt Detection Timing for External Edge-Sensitive Lines

Bus Signal Timing

Table 12 shows the PCMCIA timing for the MPC875/870.

Table 12. PCMCIA Timing

Num	Characteristic	33 MHz		40 MHz		66 MHz		80 MHz		Unit
		Min	Max	Min	Max	Min	Max	Min	Max	
P44	A(0:31), $\overline{\text{REG}}$ valid to PCMCIA strobe asserted ¹ (MIN = $0.75 \times B1 - 2.00$)	20.70	—	16.70	—	9.40	—	7.40	—	ns
P45	A(0:31), $\overline{\text{REG}}$ valid to ALE negation ¹ (MIN = $1.00 \times B1 - 2.00$)	28.30	—	23.00	—	13.20	—	10.50	—	ns
P46	CLKOUT to $\overline{\text{REG}}$ valid (MAX = $0.25 \times B1 + 8.00$)	7.60	15.60	6.30	14.30	3.80	11.80	3.13	11.13	ns
P47	CLKOUT to $\overline{\text{REG}}$ invalid (MIN = $0.25 \times B1 + 1.00$)	8.60	—	7.30	—	4.80	—	4.125	—	ns
P48	CLKOUT to $\overline{\text{CE1}}$, $\overline{\text{CE2}}$ asserted (MAX = $0.25 \times B1 + 8.00$)	7.60	15.60	6.30	14.30	3.80	11.80	3.13	11.13	ns
P49	CLKOUT to $\overline{\text{CE1}}$, $\overline{\text{CE2}}$ negated (MAX = $0.25 \times B1 + 8.00$)	7.60	15.60	6.30	14.30	3.80	11.80	3.13	11.13	ns
P50	CLKOUT to $\overline{\text{PCOE}}$, $\overline{\text{IORD}}$, $\overline{\text{PCWE}}$, $\overline{\text{IOWR}}$ assert time (MAX = $0.00 \times B1 + 11.00$)	—	11.00	—	11.00	—	11.00	—	11.00	ns
P51	CLKOUT to $\overline{\text{PCOE}}$, $\overline{\text{IORD}}$, $\overline{\text{PCWE}}$, $\overline{\text{IOWR}}$ negate time (MAX = $0.00 \times B1 + 11.00$)	2.00	11.00	2.00	11.00	2.00	11.00	2.00	11.00	ns
P52	CLKOUT to ALE assert time (MAX = $0.25 \times B1 + 6.30$)	7.60	13.80	6.30	12.50	3.80	10.00	3.13	9.40	ns
P53	CLKOUT to ALE negate time (MAX = $0.25 \times B1 + 8.00$)	—	15.60	—	14.30	—	11.80	—	11.13	ns
P54	$\overline{\text{PCWE}}$, $\overline{\text{IOWR}}$ negated to D(0:31) invalid ¹ (MIN = $0.25 \times B1 - 2.00$)	5.60	—	4.30	—	1.80	—	1.125	—	ns
P55	$\overline{\text{WAITA}}$ and $\overline{\text{WAITB}}$ valid to CLKOUT rising edge ¹ (MIN = $0.00 \times B1 + 8.00$)	8.00	—	8.00	—	8.00	—	8.00	—	ns
P56	CLKOUT rising edge to $\overline{\text{WAITA}}$ and $\overline{\text{WAITB}}$ invalid ¹ (MIN = $0.00 \times B1 +$ 2.00)	2.00	—	2.00	—	2.00	—	2.00	—	ns

¹ PSST = 1. Otherwise add PSST times cycle time.
PSHT = 0. Otherwise add PSHT times cycle time.

These synchronous timings define when the $\overline{\text{WAITA}}$ signals are detected in order to freeze (or relieve) the PCMCIA current cycle. The $\overline{\text{WAITA}}$ assertion will be effective only if it is detected 2 cycles before the PSL timer expiration. See Chapter 16, "PCMCIA Interface," in the *MPC885 PowerQUICC Family User's Manual*.

Bus Signal Timing

Figure 26 provides the PCMCIA access cycle timing for the external bus read.

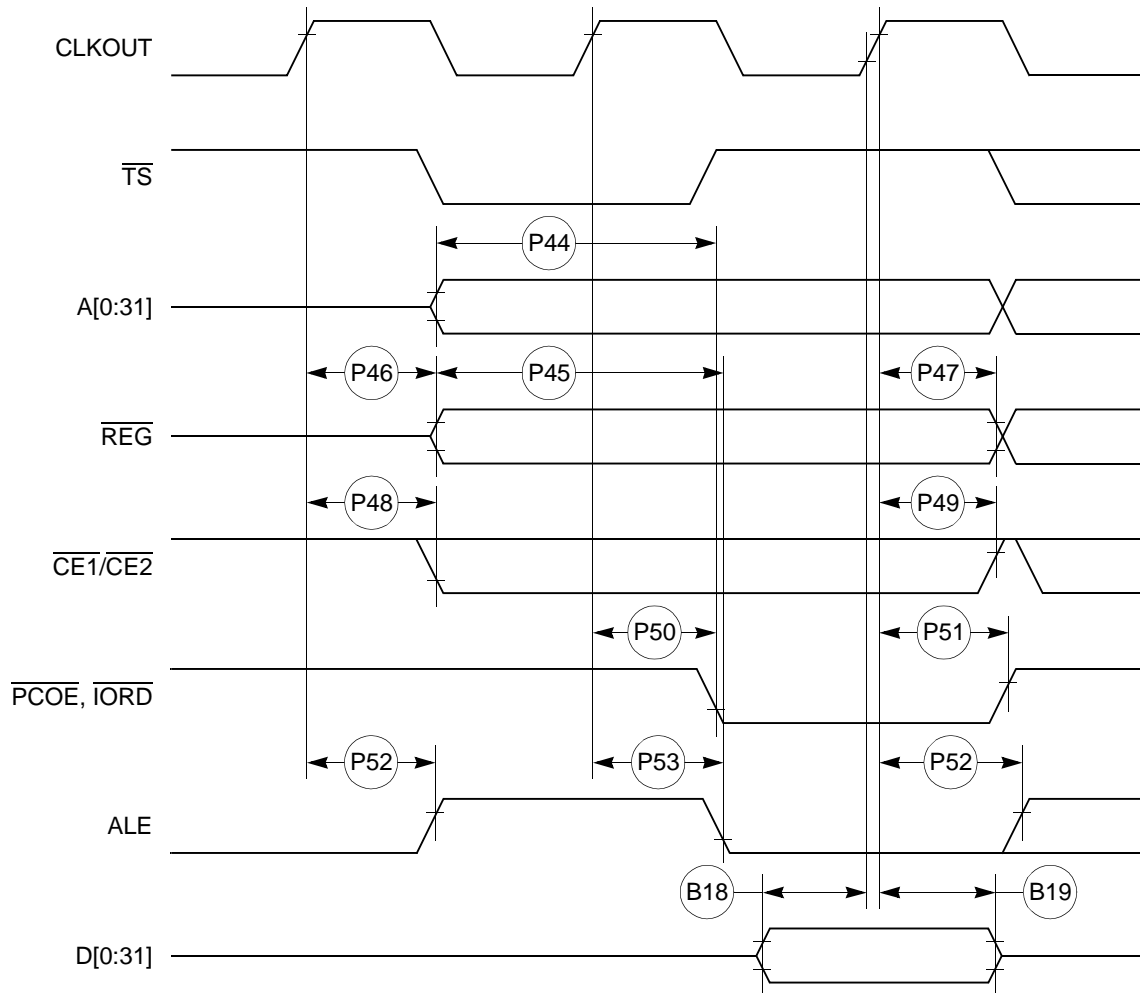

Figure 26. PCMCIA Access Cycles Timing External Bus Read

Bus Signal Timing

Figure 27 provides the PCMCIA access cycle timing for the external bus write.

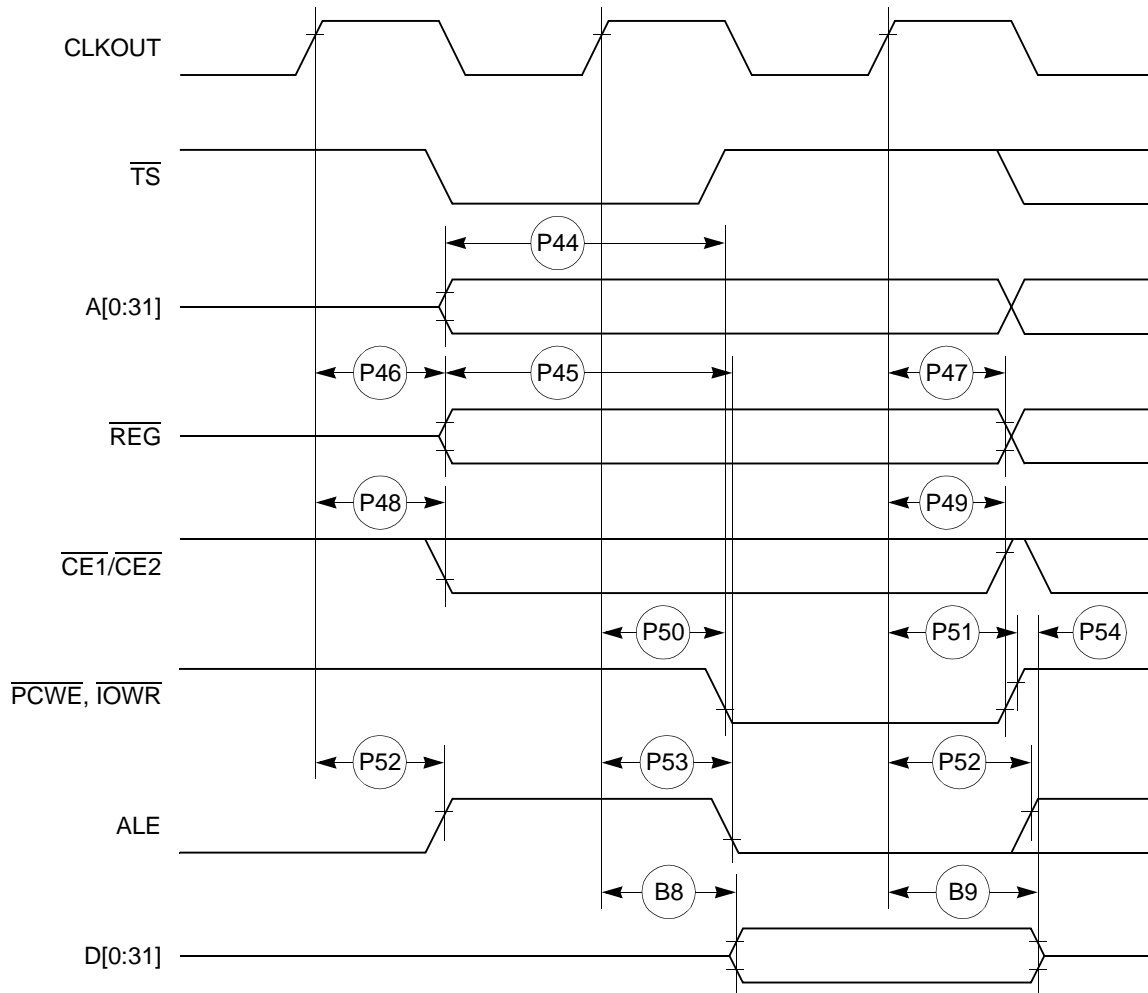

Figure 27. PCMCIA Access Cycles Timing External Bus Write

Figure 28 provides the PCMCIA \overline{WAITA} signals detection timing.

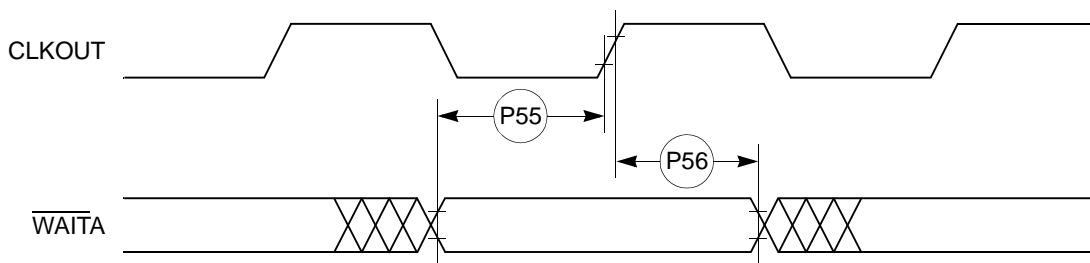

Figure 28. PCMCIA \overline{WAITA} Signals Detection Timing

Bus Signal Timing

Table 13 shows the PCMCIA port timing for the MPC875/870.

Table 13. PCMCIA Port Timing

Num	Characteristic	33 MHz		40 MHz		66 MHz		80 MHz		Unit
		Min	Max	Min	Max	Min	Max	Min	Max	
P57	CLKOUT to OPx valid (MAX = $0.00 \times B1 + 19.00$)	—	19.00	—	19.00	—	19.00	—	19.00	ns
P58	$\overline{\text{HRESET}}$ negated to OPx drive ¹ (MIN = $0.75 \times B1 + 3.00$)	25.70	—	21.70	—	14.40	—	12.40	—	ns
P59	IP_Xx valid to CLKOUT rising edge (MIN = $0.00 \times B1 + 5.00$)	5.00	—	5.00	—	5.00	—	5.00	—	ns
P60	CLKOUT rising edge to IP_Xx invalid (MIN = $0.00 \times B1 + 1.00$)	1.00	—	1.00	—	1.00	—	1.00	—	ns

¹ OP2 and OP3 only.

Figure 29 provides the PCMCIA output port timing for the MPC875/870.

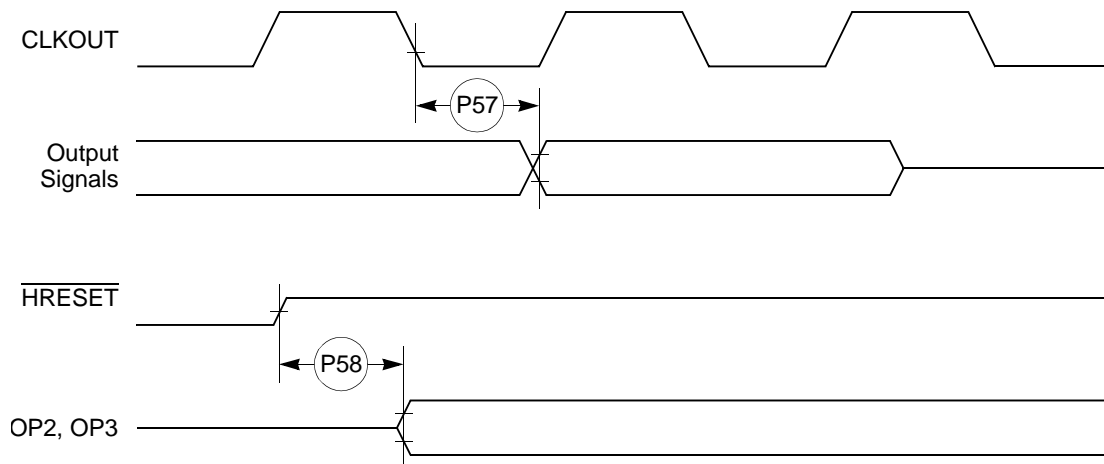

Figure 29. PCMCIA Output Port Timing

Figure 30 provides the PCMCIA input port timing for the MPC875/870.

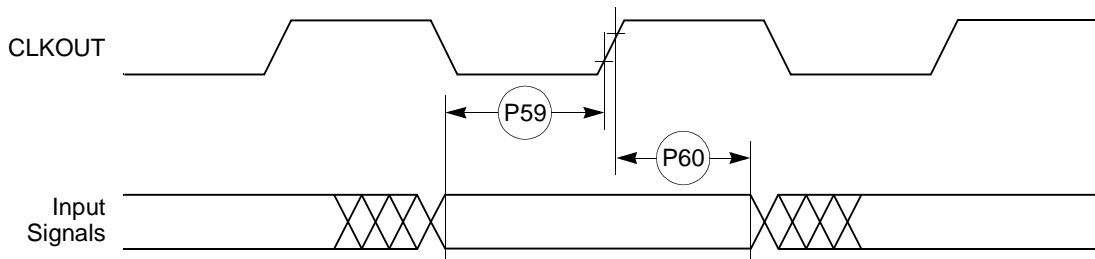

Figure 30. PCMCIA Input Port Timing

Bus Signal Timing

Table 14 shows the debug port timing for the MPC875/870.

Table 14. Debug Port Timing

Num	Characteristic	All Frequencies		Unit
		Min	Max	
D61	DSCK cycle time	$3 \times T_{\text{CLOCKOUT}}$		—
D62	DSCK clock pulse width	$1.25 \times T_{\text{CLOCKOUT}}$		—
D63	DSCK rise and fall times	0.00	3.00	ns
D64	DSDI input data setup time	8.00		ns
D65	DSDI data hold time	5.00		ns
D66	DSCK low to DSDO data valid	0.00	15.00	ns
D67	DSCK low to DSDO invalid	0.00	2.00	ns

Figure 31 provides the input timing for the debug port clock.

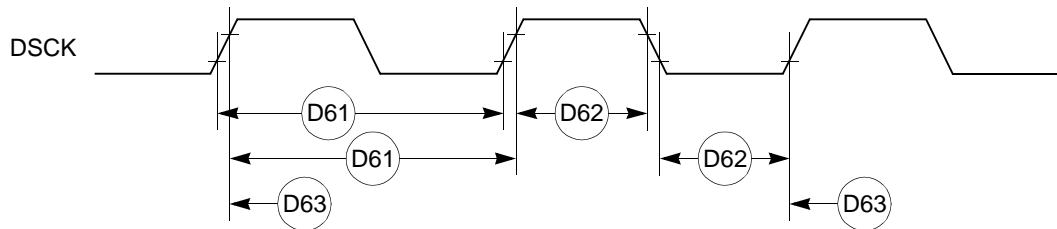

Figure 31. Debug Port Clock Input Timing

Figure 32 provides the timing for the debug port.

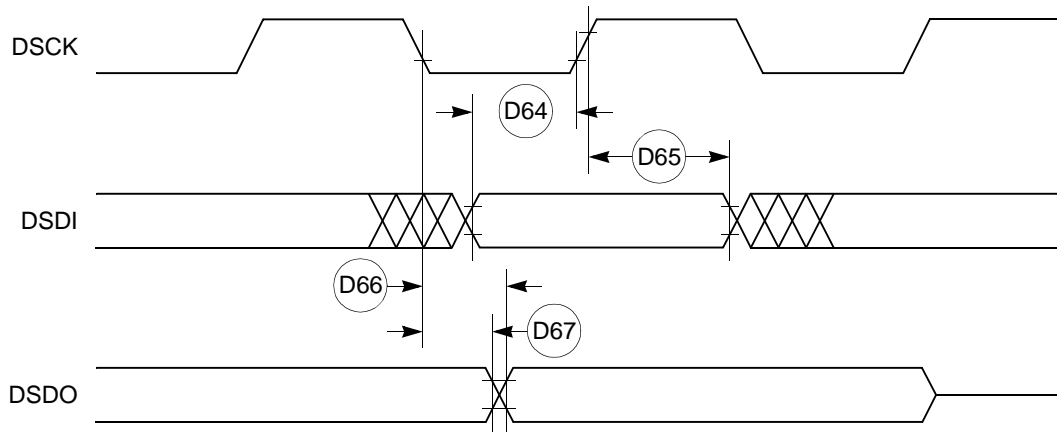

Figure 32. Debug Port Timings

Bus Signal Timing

Table 15 shows the reset timing for the MPC875/870.

Table 15. Reset Timing

Num	Characteristic	33 MHz		40 MHz		66 MHz		80 MHz		Unit
		Min	Max	Min	Max	Min	Max	Min	Max	
R69	CLKOUT to $\overline{\text{HRESET}}$ high impedance (MAX = $0.00 \times B1 + 20.00$)	—	20.00	—	20.00	—	20.00	—	20.00	ns
R70	CLKOUT to $\overline{\text{SRESET}}$ high impedance (MAX = $0.00 \times B1 + 20.00$)	—	20.00	—	20.00	—	20.00	—	20.00	ns
R71	$\overline{\text{RSTCONF}}$ pulse width (MIN = $17.00 \times B1$)	515.20	—	425.00	—	257.60	—	212.50	—	ns
R72	—	—	—	—	—	—	—	—	—	—
R73	Configuration data to $\overline{\text{HRESET}}$ rising edge setup time (MIN = $15.00 \times B1 + 50.00$)	504.50	—	425.00	—	277.30	—	237.50	—	ns
R74	Configuration data to $\overline{\text{RSTCONF}}$ rising edge setup time (MIN = $0.00 \times B1 + 350.00$)	350.00	—	350.00	—	350.00	—	350.00	—	ns
R75	Configuration data hold time after $\overline{\text{RSTCONF}}$ negation (MIN = $0.00 \times B1 + 0.00$)	0.00	—	0.00	—	0.00	—	0.00	—	ns
R76	Configuration data hold time after $\overline{\text{HRESET}}$ negation (MIN = $0.00 \times B1 + 0.00$)	0.00	—	0.00	—	0.00	—	0.00	—	ns
R77	$\overline{\text{HRESET}}$ and $\overline{\text{RSTCONF}}$ asserted to data out drive (MAX = $0.00 \times B1 + 25.00$)	—	25.00	—	25.00	—	25.00	—	25.00	ns
R78	$\overline{\text{RSTCONF}}$ negated to data out high impedance (MAX = $0.00 \times B1 + 25.00$)	—	25.00	—	25.00	—	25.00	—	25.00	ns
R79	CLKOUT of last rising edge before chip three-states $\overline{\text{HRESET}}$ to data out high impedance (MAX = $0.00 \times B1 + 25.00$)	—	25.00	—	25.00	—	25.00	—	25.00	ns
R80	DSDI, DSCK setup (MIN = $3.00 \times B1$)	90.90	—	75.00	—	45.50	—	37.50	—	ns
R81	DSDI, DSCK hold time (MIN = $0.00 \times B1 + 0.00$)	0.00	—	0.00	—	0.00	—	0.00	—	ns
R82	$\overline{\text{SRESET}}$ negated to CLKOUT rising edge for DSDI and DSCK sample (MIN = $8.00 \times B1$)	242.40	—	200.00	—	121.20	—	100.00	—	ns

Bus Signal Timing

Figure 33 shows the reset timing for the data bus configuration.

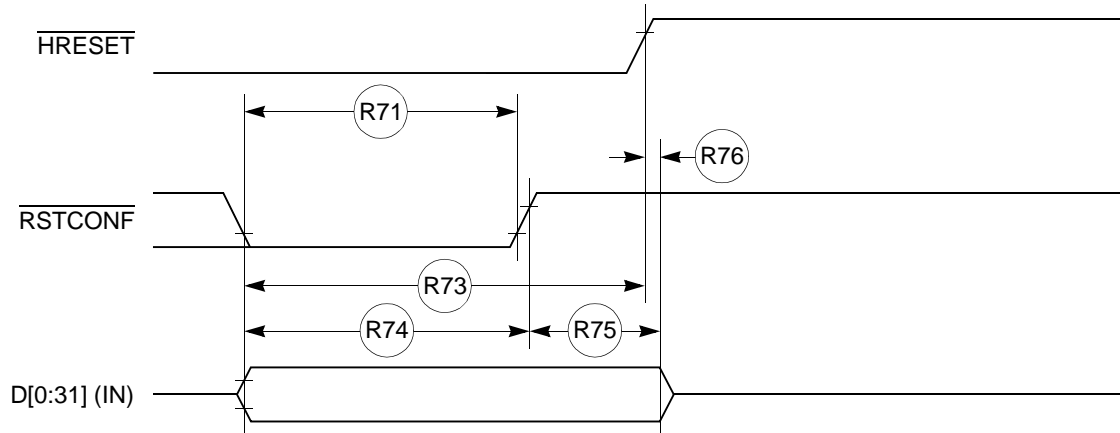

Figure 33. Reset Timing—Configuration from Data Bus

Figure 34 provides the reset timing for the data bus weak drive during configuration.

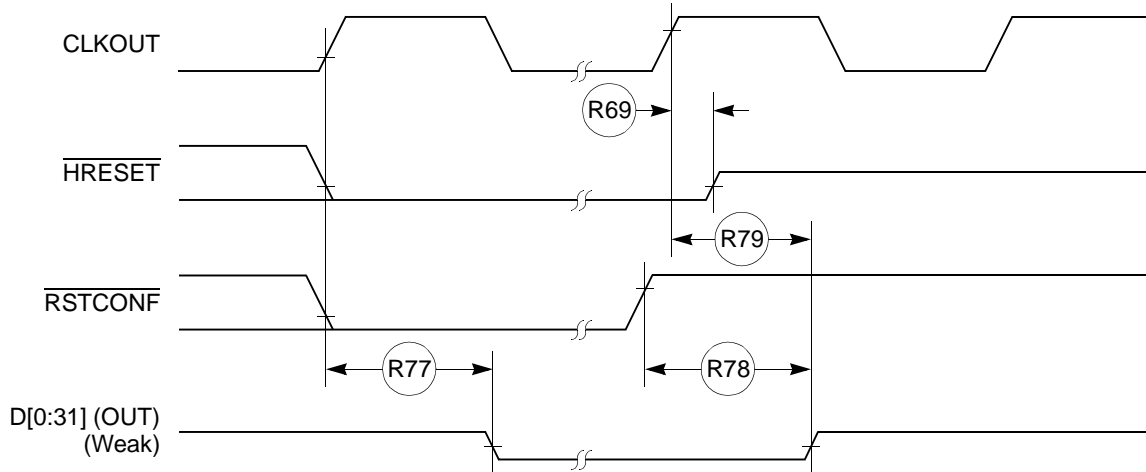

Figure 34. Reset Timing—Data Bus Weak Drive During Configuration

Figure 35 provides the reset timing for the debug port configuration.

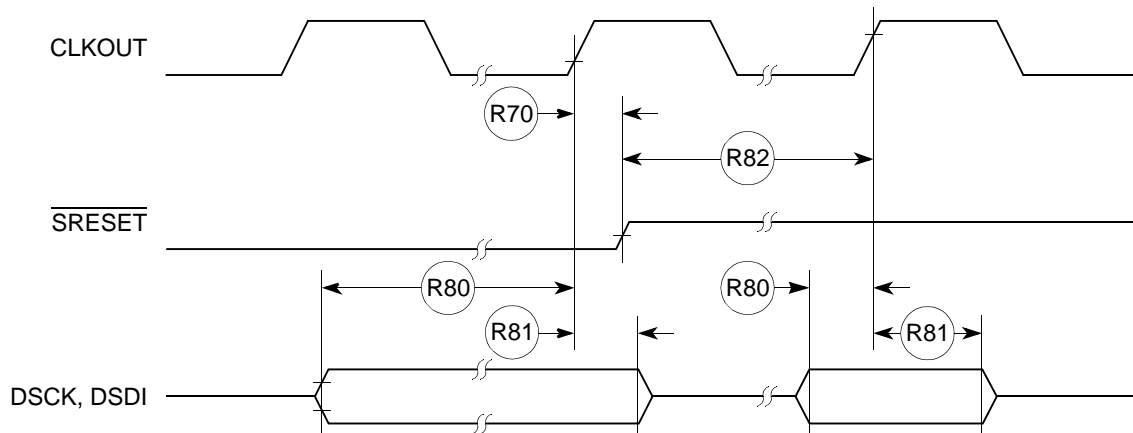

Figure 35. Reset Timing—Debug Port Configuration

12 IEEE 1149.1 Electrical Specifications

Table 16 provides the JTAG timings for the MPC875/870 shown in Figure 36 to Figure 39.

Table 16. JTAG Timing

Num	Characteristic	All Frequencies		Unit
		Min	Max	
J82	TCK cycle time	100.00	—	ns
J83	TCK clock pulse width measured at 1.5 V	40.00	—	ns
J84	TCK rise and fall times	0.00	10.00	ns
J85	TMS, TDI data setup time	5.00	—	ns
J86	TMS, TDI data hold time	25.00	—	ns
J87	TCK low to TDO data valid	—	27.00	ns
J88	TCK low to TDO data invalid	0.00	—	ns
J89	TCK low to TDO high impedance	—	20.00	ns
J90	$\overline{\text{TRST}}$ assert time	100.00	—	ns
J91	$\overline{\text{TRST}}$ setup time to TCK low	40.00	—	ns
J92	TCK falling edge to output valid	—	50.00	ns
J93	TCK falling edge to output valid out of high impedance	—	50.00	ns
J94	TCK falling edge to output high impedance	—	50.00	ns
J95	Boundary scan input valid to TCK rising edge	50.00	—	ns
J96	TCK rising edge to boundary scan input invalid	50.00	—	ns

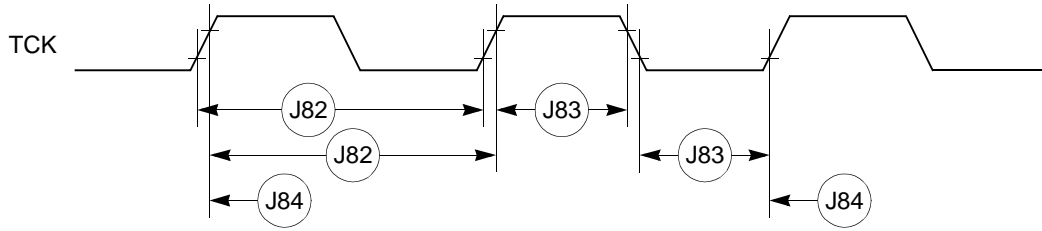

Figure 36. JTAG Test Clock Input Timing

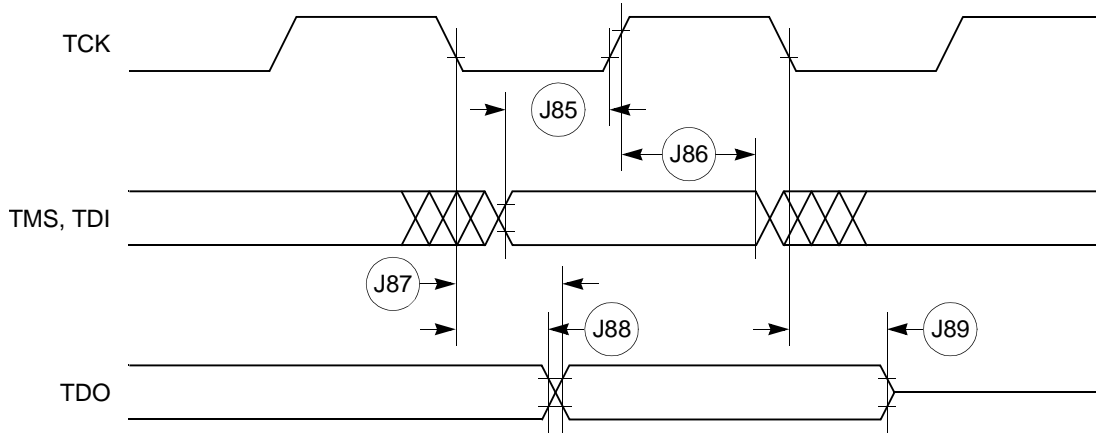

Figure 37. JTAG Test Access Port Timing Diagram

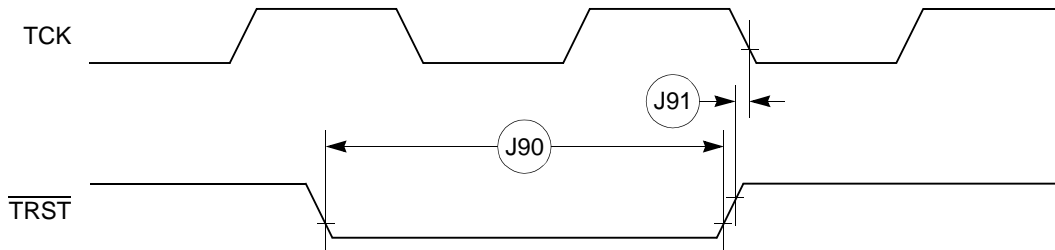

Figure 38. JTAG $\overline{\text{TRST}}$ Timing Diagram

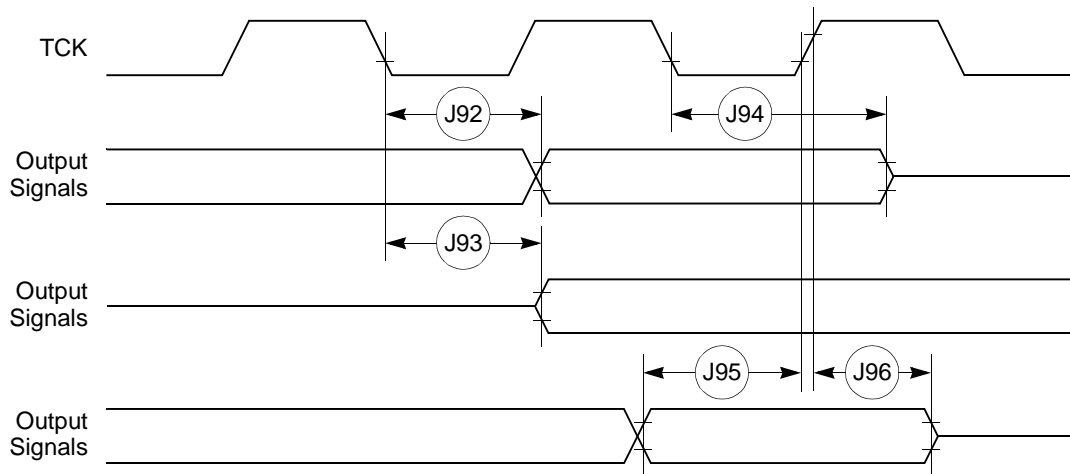

Figure 39. Boundary Scan (JTAG) Timing Diagram

13 CPM Electrical Characteristics

This section provides the AC and DC electrical specifications for the communications processor module (CPM) of the MPC875/870.

13.1 Port C Interrupt AC Electrical Specifications

Table 17 provides the timings for port C interrupts.

Table 17. Port C Interrupt Timing

Num	Characteristic	33.34 MHz		Unit
		Min	Max	
35	Port C interrupt pulse width low (edge-triggered mode)	55	—	ns
36	Port C interrupt minimum time between active edges	55	—	ns

Figure 40 shows the port C interrupt detection timing.

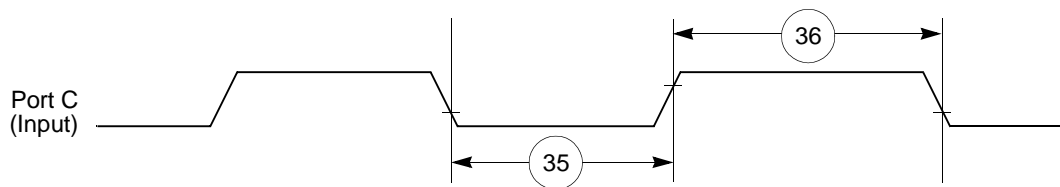

Figure 40. Port C Interrupt Detection Timing

13.2 IDMA Controller AC Electrical Specifications

Table 18 provides the IDMA controller timings as shown in Figure 41 to Figure 44.

Table 18. IDMA Controller Timing

Num	Characteristic	All Frequencies		Unit
		Min	Max	
40	$\overline{\text{DREQ}}$ setup time to clock high	7	—	ns
41	$\overline{\text{DREQ}}$ hold time from clock high ¹	TBD	—	ns
42	$\overline{\text{SDACK}}$ assertion delay from clock high	—	12	ns
43	$\overline{\text{SDACK}}$ negation delay from clock low	—	12	ns
44	$\overline{\text{SDACK}}$ negation delay from $\overline{\text{TA}}$ low	—	20	ns
45	$\overline{\text{SDACK}}$ negation delay from clock high	—	15	ns
46	$\overline{\text{TA}}$ assertion to falling edge of the clock setup time (applies to external $\overline{\text{TA}}$)	7	—	ns

¹ Applies to high-to-low mode (EDM=1)

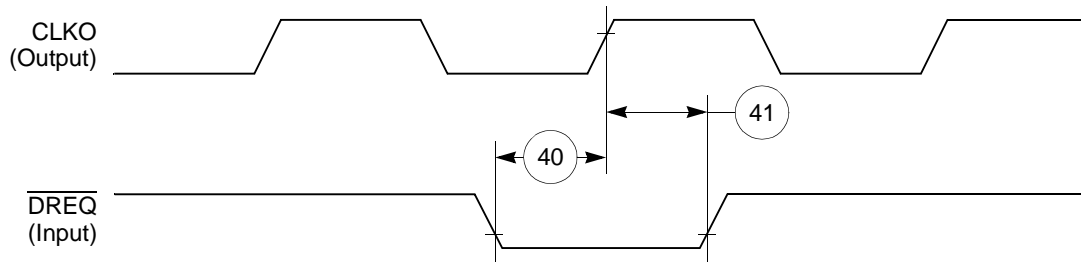

Figure 41. IDMA External Requests Timing Diagram

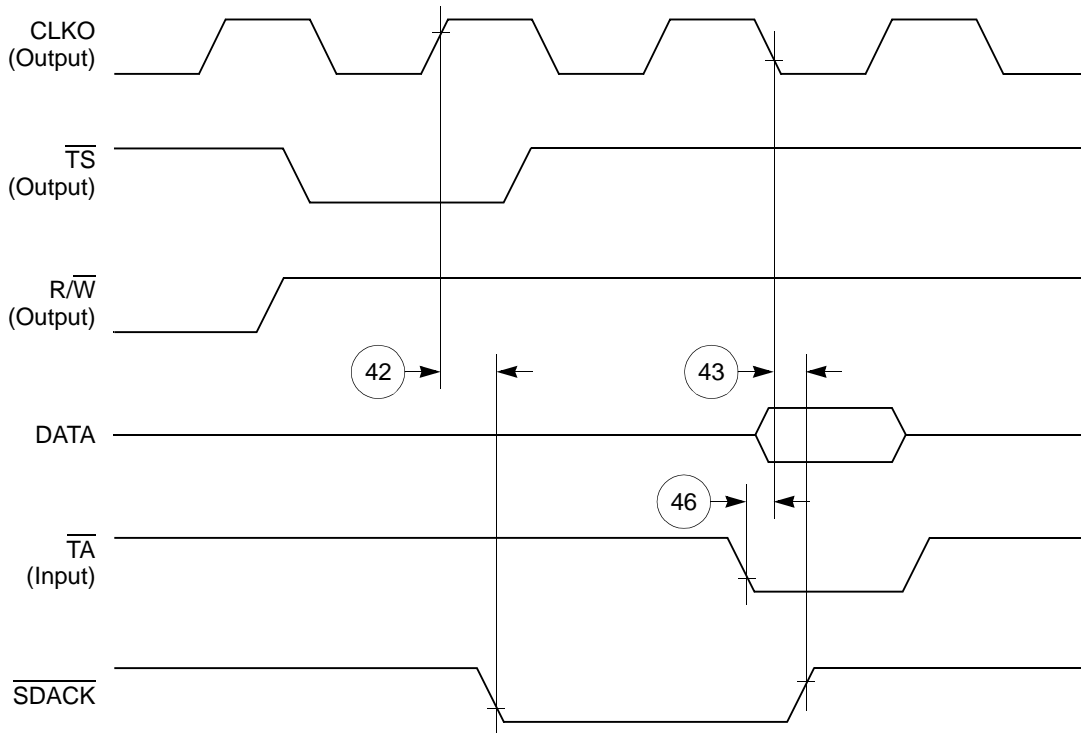

Figure 42. $\overline{\text{SDACK}}$ Timing Diagram—Peripheral Write, Externally-Generated $\overline{\text{TA}}$

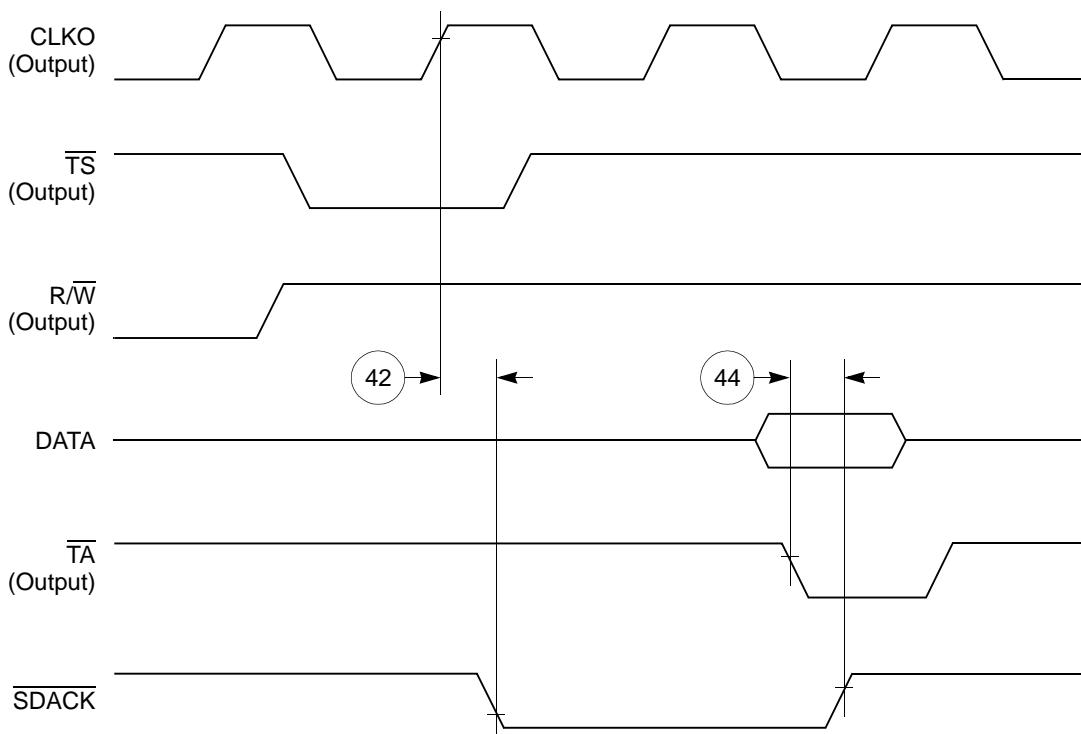

Figure 43. $\overline{\text{SDACK}}$ Timing Diagram—Peripheral Write, Internally-Generated $\overline{\text{TA}}$

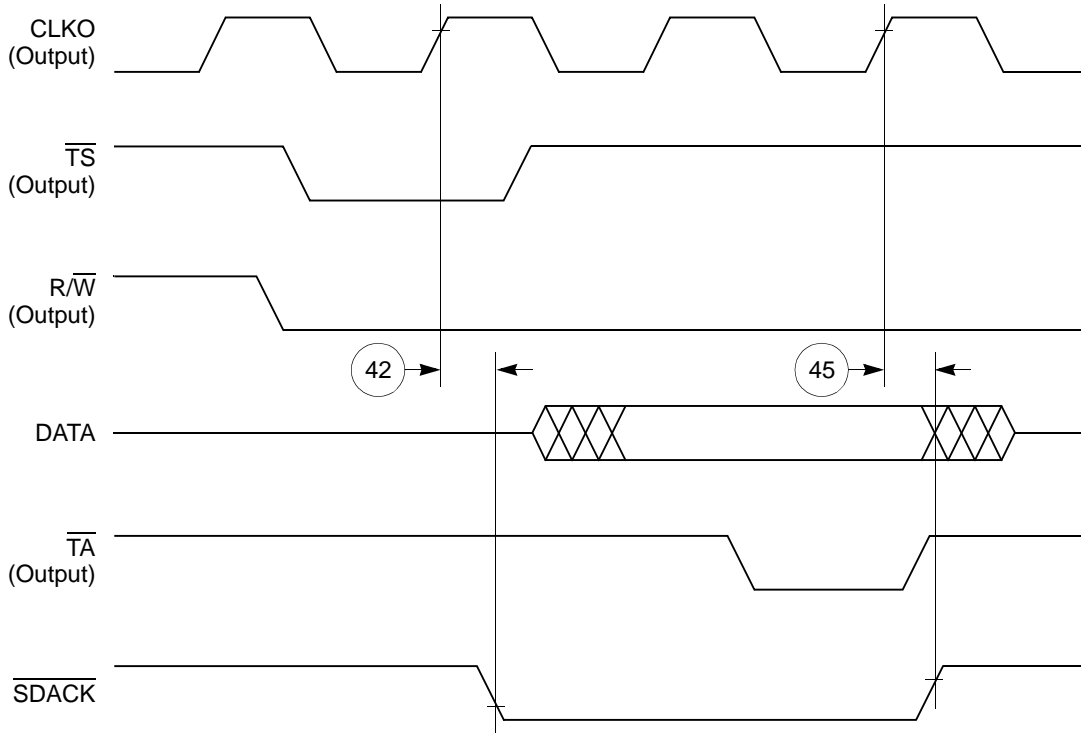

Figure 44. $\overline{\text{SDACK}}$ Timing Diagram—Peripheral Read, Internally-Generated $\overline{\text{TA}}$

13.3 Baud Rate Generator AC Electrical Specifications

Table 19 provides the baud rate generator timings as shown in Figure 45.

Table 19. Baud Rate Generator Timing

Num	Characteristic	All Frequencies		Unit
		Min	Max	
50	BRGO rise and fall time	—	10	ns
51	BRGO duty cycle	40	60	%
52	BRGO cycle	40	—	ns

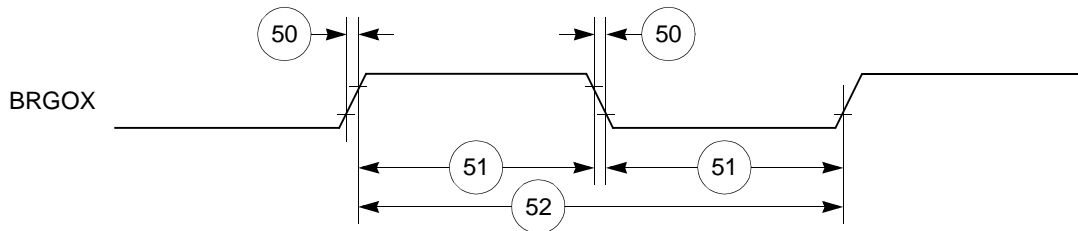

Figure 45. Baud Rate Generator Timing Diagram

13.4 Timer AC Electrical Specifications

Table 20 provides the general-purpose timer timings as shown in Figure 46.

Table 20. Timer Timing

Num	Characteristic	All Frequencies		Unit
		Min	Max	
61	TIN/TGATE rise and fall time	10	—	ns
62	TIN/TGATE low time	1	—	clk
63	TIN/TGATE high time	2	—	clk
64	TIN/TGATE cycle time	3	—	clk
65	CLKO low to TOUT valid	3	25	ns

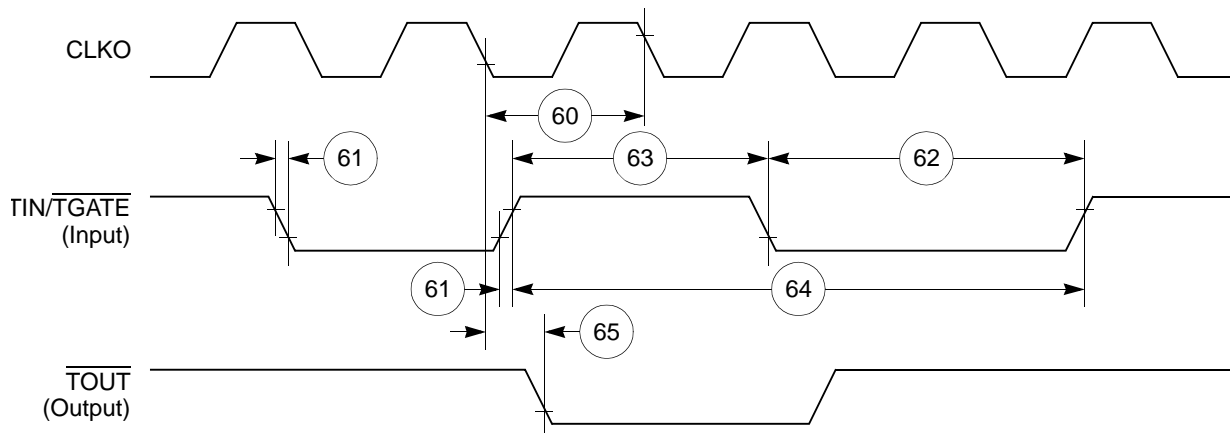

Figure 46. CPM General-Purpose Timers Timing Diagram

13.5 Serial Interface AC Electrical Specifications

Table 21 provides the serial interface (SI) timings as shown in Figure 47 to Figure 51.

Table 21. SI Timing

Num	Characteristic	All Frequencies		Unit
		Min	Max	
70	L1RCLKB, L1TCLKB frequency (DSC = 0) ^{1, 2}	—	SYNCCLK /2.5	MHz
71	L1RCLKB, L1TCLKB width low (DSC = 0) ²	P + 10	—	ns
71a	L1RCLKB, L1TCLKB width high (DSC = 0) ³	P + 10	—	ns
72	L1TXDB, L1ST1 and L1ST2, L1RQ, L1CLKO rise/fall time	—	15.00	ns
73	L1RSYNCB, L1TSYNCB valid to L1CLKB edge (SYNC setup time)	20.00	—	ns

Table 21. SI Timing (continued)

Num	Characteristic	All Frequencies		Unit
		Min	Max	
74	L1CLKB edge to L1RSYNCB, L1TSYNCB, invalid (SYNC hold time)	35.00	—	ns
75	L1RSYNCB, L1TSYNCB rise/fall time	—	15.00	ns
76	L1RXDB valid to L1CLKB edge (L1RXDB setup time)	17.00	—	ns
77	L1CLKB edge to L1RXDB invalid (L1RXDB hold time)	13.00	—	ns
78	L1CLKB edge to L1ST1 and L1ST2 valid ⁴	10.00	45.00	ns
78A	L1SYNCB valid to L1ST1 and L1ST2 valid	10.00	45.00	ns
79	L1CLKB edge to L1ST1 and L1ST2 invalid	10.00	45.00	ns
80	L1CLKB edge to L1TXDB valid	10.00	55.00	ns
80A	L1TSYNCB valid to L1TXDB valid ⁴	10.00	55.00	ns
81	L1CLKB edge to L1TXDB high impedance	0.00	42.00	ns
82	L1RCLKB, L1TCLKB frequency (DSC = 1)	—	16.00 or SYNCCLK / 2	MHz
83	L1RCLKB, L1TCLKB width low (DSC = 1)	P + 10	—	ns
83a	L1RCLKB, L1TCLKB width high (DSC = 1) ³	P + 10	—	ns
84	L1CLKB edge to L1CLKOB valid (DSC = 1)	—	30.00	ns
85	$\overline{L1RQB}$ valid before falling edge of L1TSYNCB ⁴	1.00	—	L1TCLK
86	L1GRB setup time ²	42.00	—	ns
87	L1GRB hold time	42.00	—	ns
88	L1CLKB edge to L1SYNCB valid (FSD = 00) CNT = 0000, BYT = 0, DSC = 0)	—	0.00	ns

¹ The ratio SyncCLK/L1RCLKB must be greater than 2.5/1.

² These specs are valid for IDL mode only.

³ Where P = 1/CLKOUT. Thus for a 25-MHz CLK01 rate, P = 40 ns.

⁴ These strobes and TxD on the first bit of the frame become valid after the L1CLKB edge or L1SYNCB, whichever comes later.

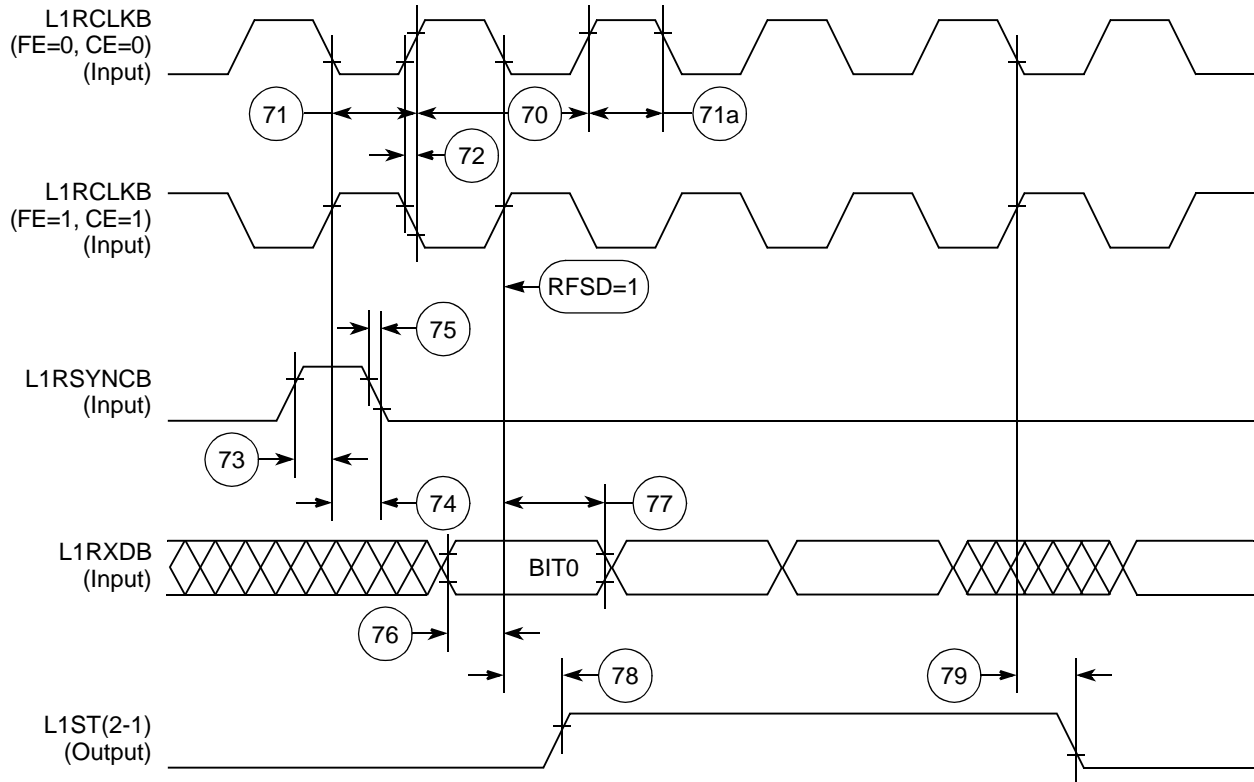

Figure 47. SI Receive Timing Diagram with Normal Clocking (DSC = 0)

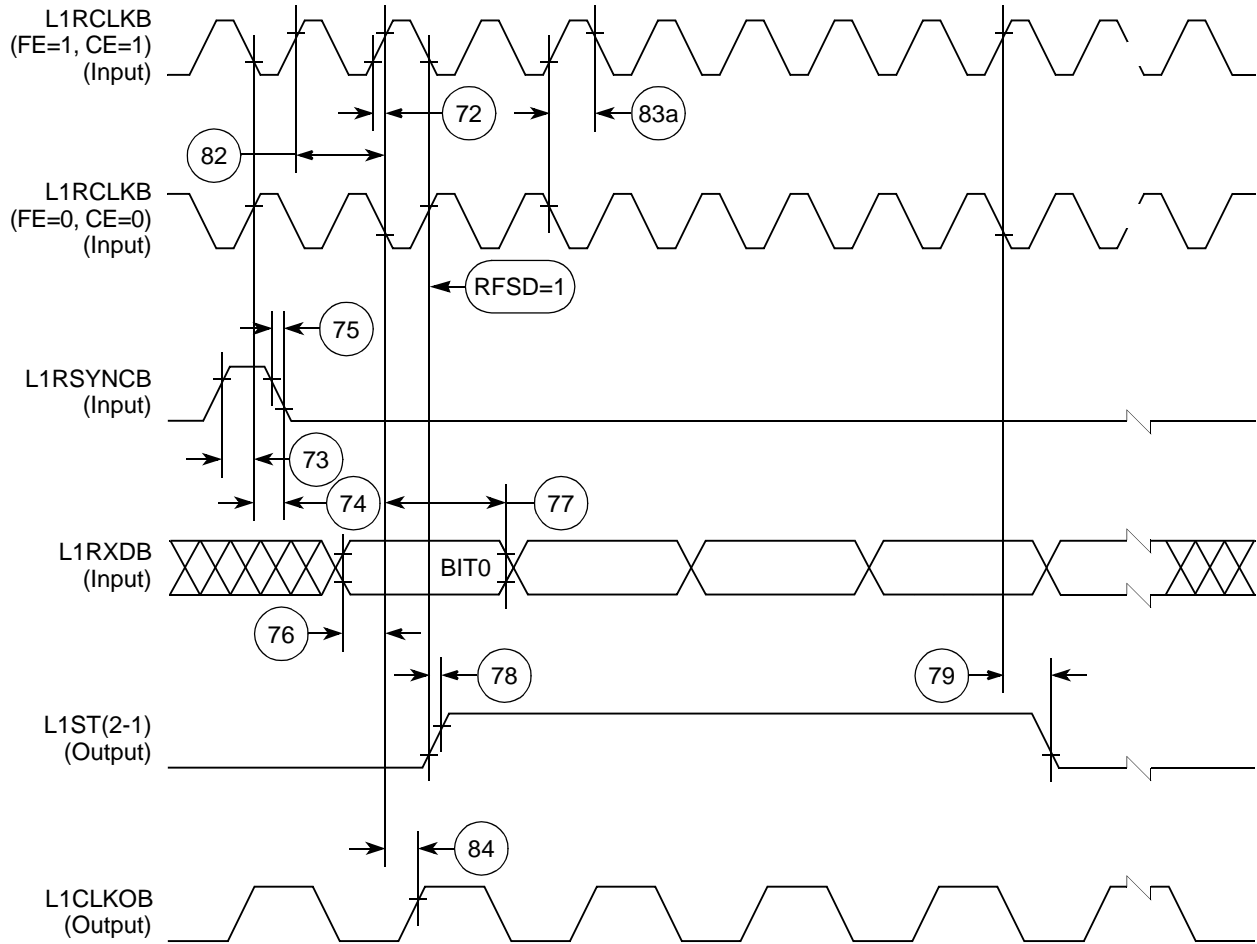

Figure 48. SI Receive Timing with Double-Speed Clacking (DSC = 1)

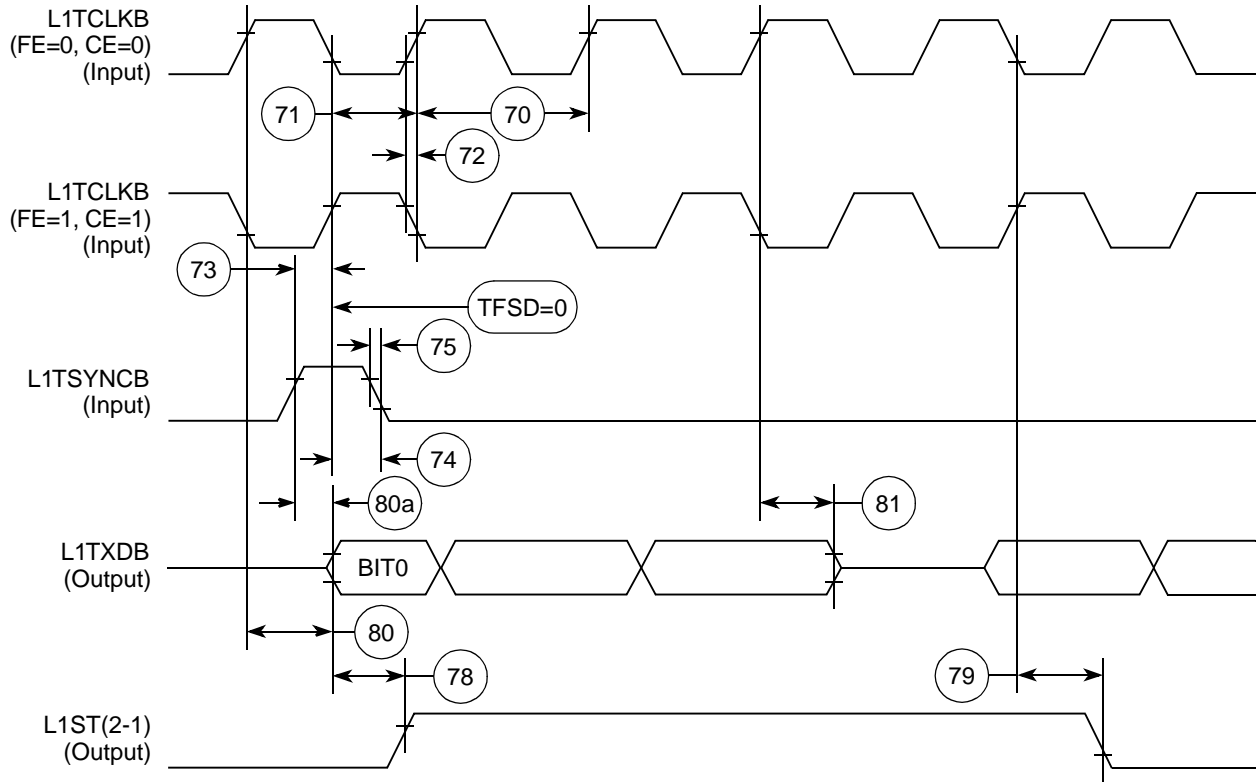

Figure 49. SI Transmit Timing Diagram (DSC = 0)

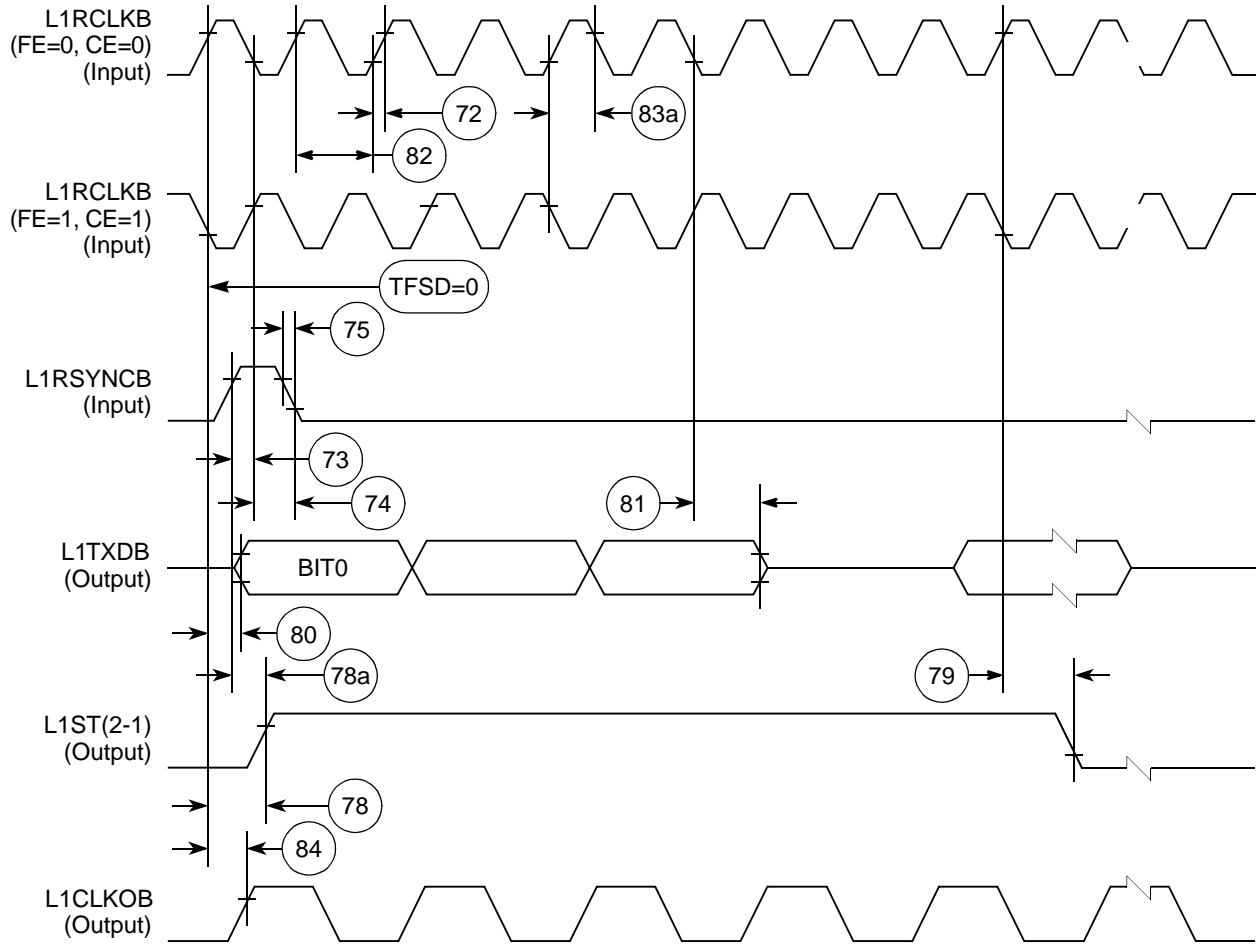

Figure 50. SI Transmit Timing with Double Speed Clocking (DSC = 1)

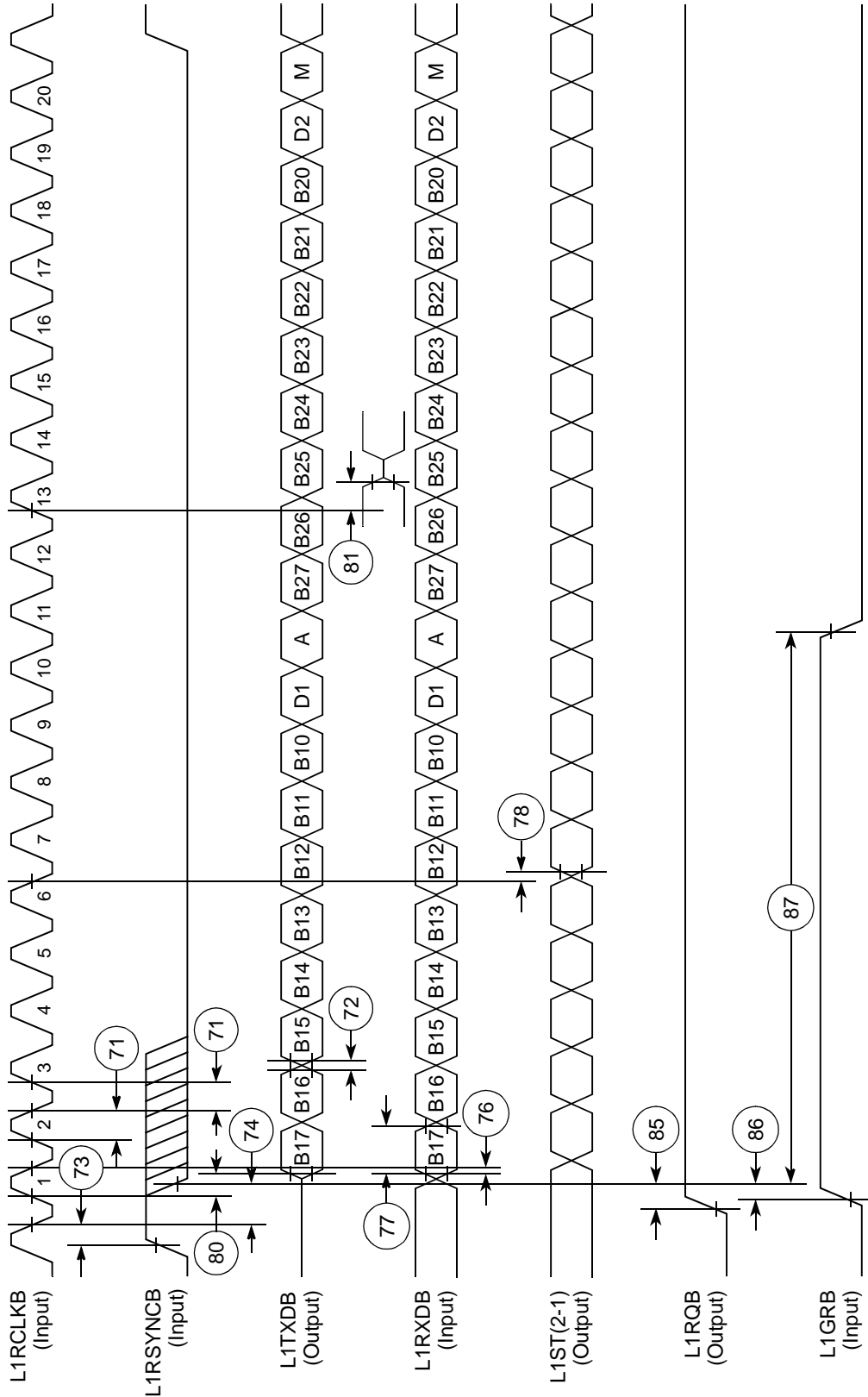

Figure 51. IDL Timing

13.6 SCC in NMSI Mode Electrical Specifications

Table 22 provides the NMSI external clock timing.

Table 22. NMSI External Clock Timing

Num	Characteristic	All Frequencies		Unit
		Min	Max	
100	RCLK3 and TCLK3 width high ¹	1/SYNCCLK	—	ns
101	RCLK3 and TCLK3 width low	1/SYNCCLK +5	—	ns
102	RCLK3 and TCLK3 rise/fall time	—	15.00	ns
103	TXD3 active delay (from TCLK3 falling edge)	0.00	50.00	ns
104	$\overline{\text{RTS3}}$ active/inactive delay (from TCLK3 falling edge)	0.00	50.00	ns
105	$\overline{\text{CTS3}}$ setup time to TCLK3 rising edge	5.00	—	ns
106	RXD3 setup time to RCLK3 rising edge	5.00	—	ns
107	RXD3 hold time from RCLK3 rising edge ²	5.00	—	ns
108	$\overline{\text{CD3}}$ setup time to RCLK3 rising edge	5.00	—	ns

¹ The ratios SyncCLK/RCLK3 and SyncCLK/TCLK3 must be greater than or equal to 2.25/1.

² Also applies to $\overline{\text{CD}}$ and $\overline{\text{CTS}}$ hold time when they are used as external sync signals.

Table 23 provides the NMSI internal clock timing.

Table 23. NMSI Internal Clock Timing

Num	Characteristic	All Frequencies		Unit
		Min	Max	
100	RCLK3 and TCLK3 frequency ¹	0.00	SYNCCLK/3	MHz
102	RCLK3 and TCLK3 rise/fall time	—	—	ns
103	TXD3 active delay (from TCLK3 falling edge)	0.00	30.00	ns
104	$\overline{\text{RTS3}}$ active/inactive delay (from TCLK3 falling edge)	0.00	30.00	ns
105	$\overline{\text{CTS3}}$ setup time to TCLK3 rising edge	40.00	—	ns
106	RXD3 setup time to RCLK3 rising edge	40.00	—	ns
107	RXD3 hold time from RCLK3 rising edge ²	0.00	—	ns
108	$\overline{\text{CD3}}$ setup time to RCLK3 rising edge	40.00	—	ns

¹ The ratios SyncCLK/RCLK3 and SyncCLK/TCLK3 must be greater or equal to 3/1.

² Also applies to $\overline{\text{CD}}$ and $\overline{\text{CTS}}$ hold time when they are used as external sync signals

Figure 52 through Figure 54 show the NMSI timings.

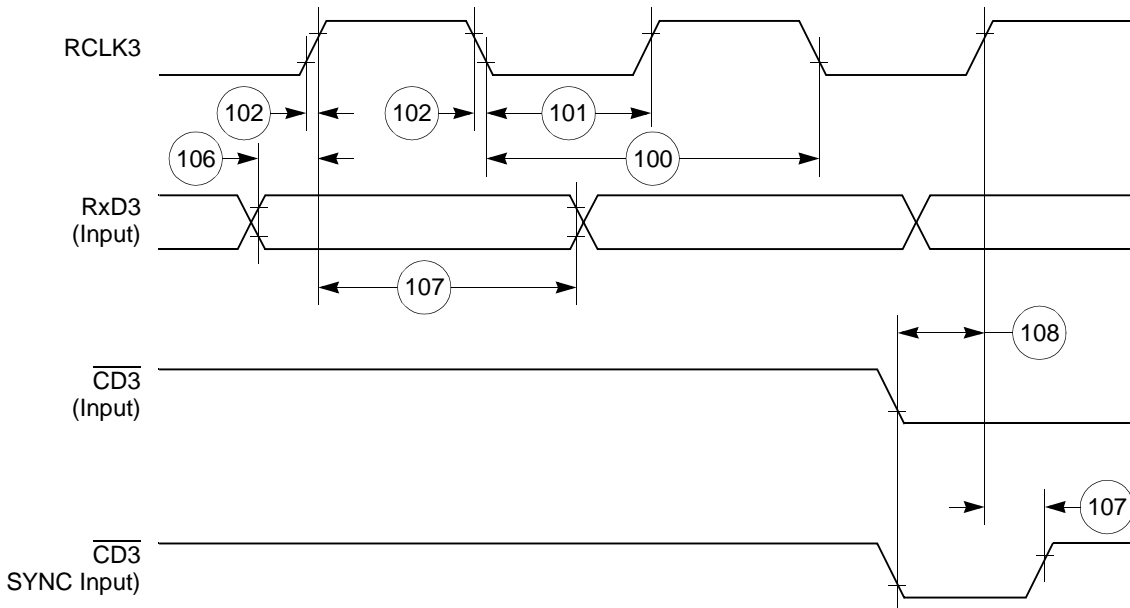

Figure 52. SCC NMSI Receive Timing Diagram

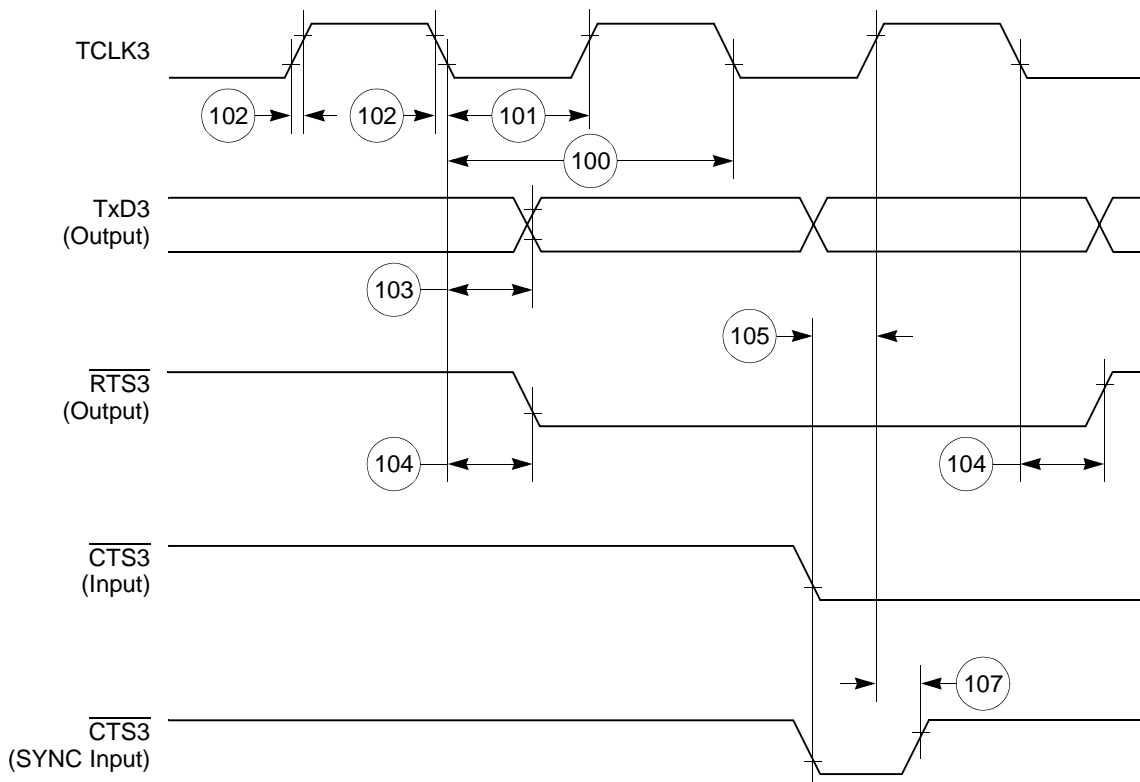

Figure 53. SCC NMSI Transmit Timing Diagram

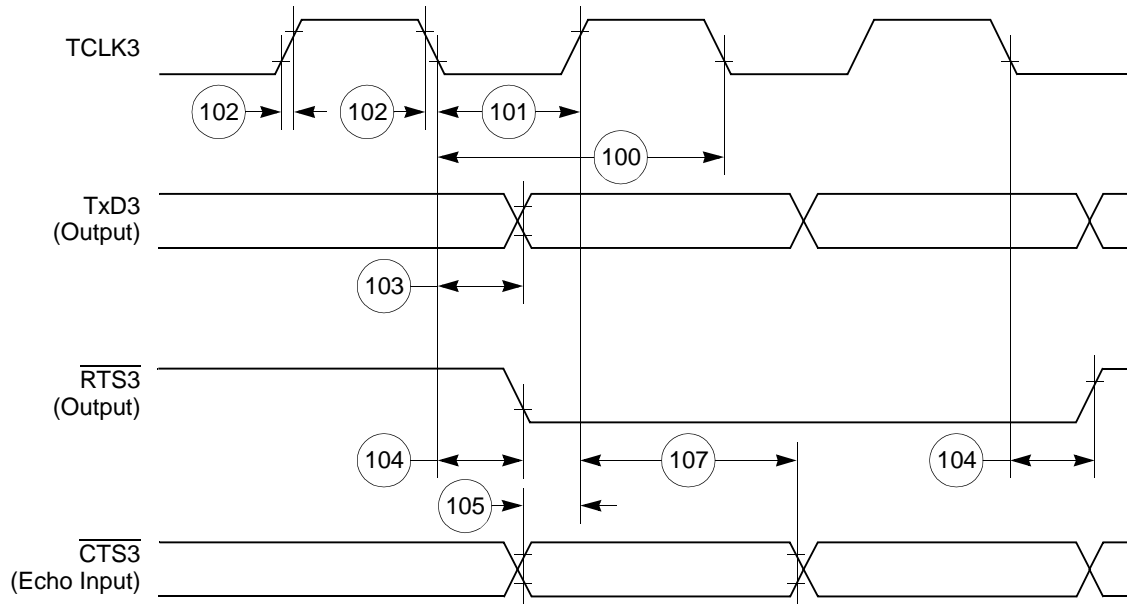

Figure 54. HDLC Bus Timing Diagram

13.7 Ethernet Electrical Specifications

Table 24 provides the Ethernet timings as shown in Figure 55 to Figure 57.

Table 24. Ethernet Timing

Num	Characteristic	All Frequencies		Unit
		Min	Max	
120	CLSN width high	40	—	ns
121	RCLK3 rise/fall time	—	15	ns
122	RCLK3 width low	40	—	ns
123	RCLK3 clock period ¹	80	120	ns
124	RXD3 setup time	20	—	ns
125	RXD3 hold time	5	—	ns
126	RENA active delay (from RCLK3 rising edge of the last data bit)	10	—	ns
127	RENA width low	100	—	ns
128	TCLK3 rise/fall time	—	15	ns
129	TCLK3 width low	40	—	ns
130	TCLK3 clock period ¹	99	101	ns
131	TXD3 active delay (from TCLK3 rising edge)	—	50	ns
132	TXD3 inactive delay (from TCLK3 rising edge)	6.5	50	ns

Table 24. Ethernet Timing (continued)

Num	Characteristic	All Frequencies		Unit
		Min	Max	
133	TENA active delay (from TCLK3 rising edge)	10	50	ns
134	TENA inactive delay (from TCLK3 rising edge)	10	50	ns
138	CLKO1 low to $\overline{\text{SDACK}}$ asserted ²	—	20	ns
139	CLKO1 low to $\overline{\text{SDACK}}$ negated ²	—	20	ns

¹ The ratios SyncCLK/RCLK3 and SyncCLK/TCLK3 must be greater than or equal to 2/1.

² $\overline{\text{SDACK}}$ is asserted whenever the SDMA writes the incoming frame DA into memory.

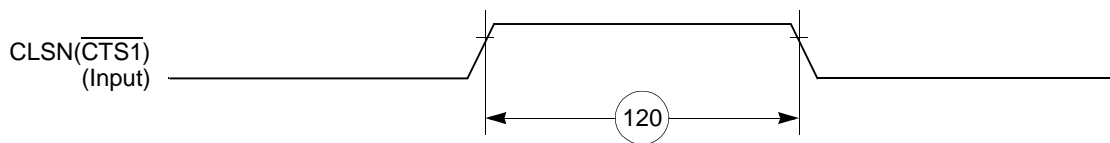

Figure 55. Ethernet Collision Timing Diagram

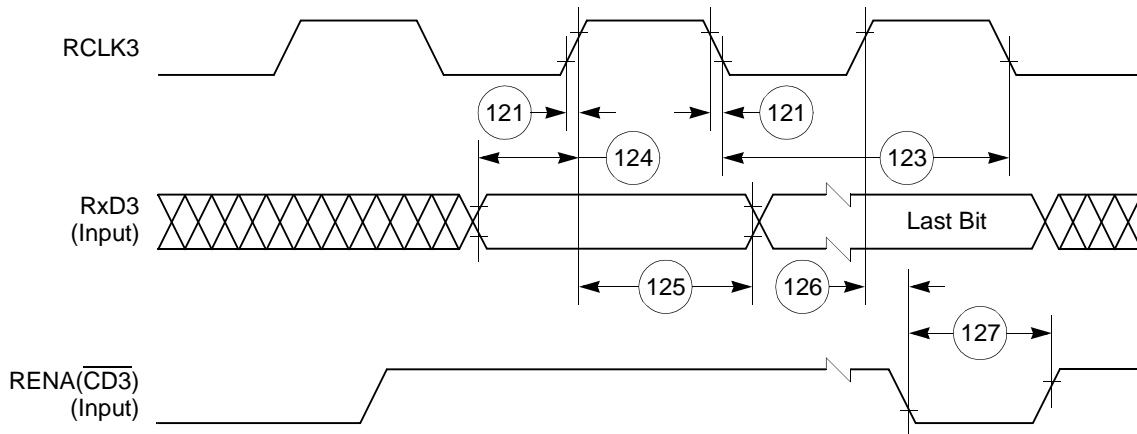
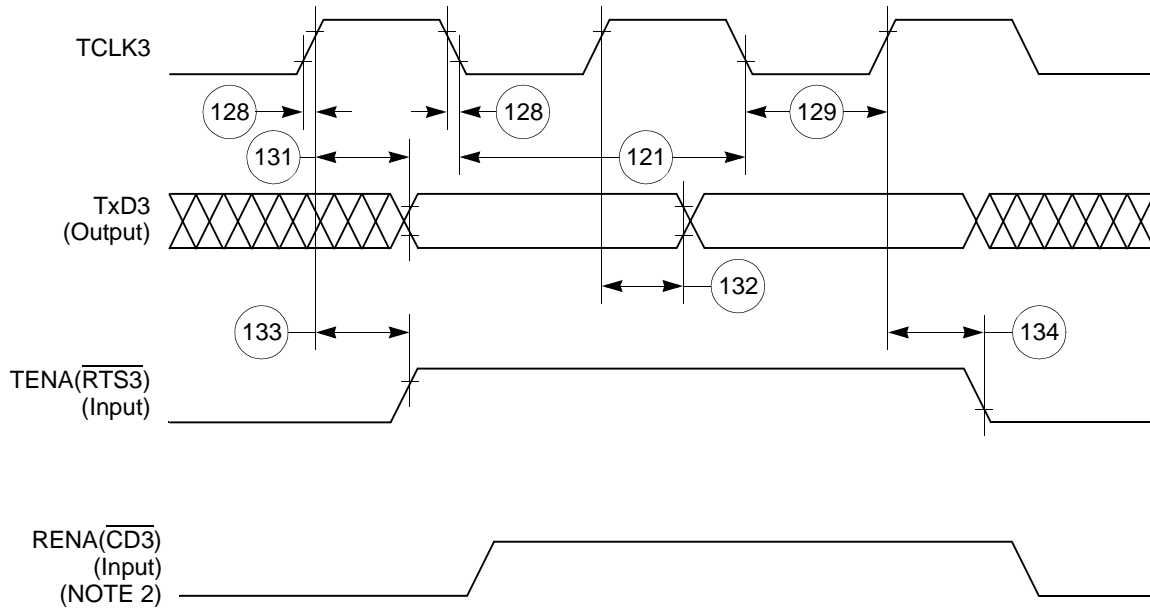

Figure 56. Ethernet Receive Timing Diagram



- NOTES:
1. Transmit clock invert (TCI) bit in GSMR is set.
 2. If RENA is negated before TENA or RENA is not asserted at all during transmit, then the CSL bit is set in the buffer descriptor at the end of the frame transmission.

Figure 57. Ethernet Transmit Timing Diagram

13.8 SMC Transparent AC Electrical Specifications

Table 25 provides the SMC transparent timings as shown in Figure 58.

Table 25. SMC Transparent Timing

Num	Characteristic	All Frequencies		Unit
		Min	Max	
150	SMCLK clock period ¹	100	—	ns
151	SMCLK width low	50	—	ns
151A	SMCLK width high	50	—	ns
152	SMCLK rise/fall time	—	15	ns
153	SMTXD active delay (from SMCLK falling edge)	10	50	ns
154	SMRXD/SMSYNC setup time	20	—	ns
155	RXD1/SMSYNC hold time	5	—	ns

¹ SyncCLK must be at least twice as fast as SMCLK.

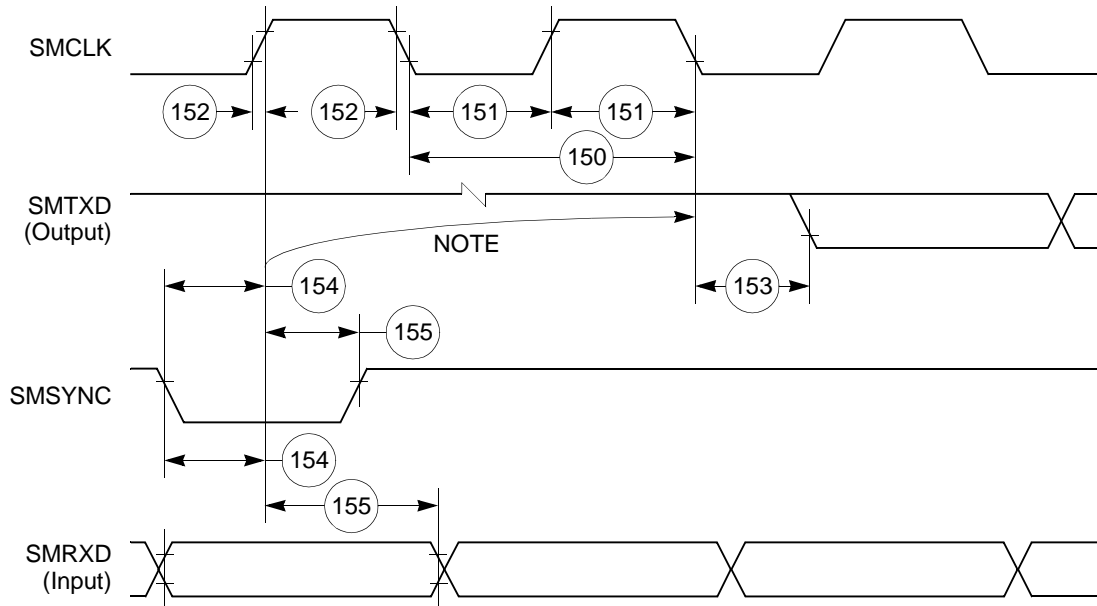

NOTE:
1. This delay is equal to an integer number of character-length clocks.

Figure 58. SMC Transparent Timing Diagram

13.9 SPI Master AC Electrical Specifications

Table 26 provides the SPI master timings as shown in Figure 59 and Figure 60.

Table 26. SPI Master Timing

Num	Characteristic	All Frequencies		Unit
		Min	Max	
160	MASTER cycle time	4	1024	t _{cyc}
161	MASTER clock (SCK) high or low time	2	512	t _{cyc}
162	MASTER data setup time (inputs)	15	—	ns
163	Master data hold time (inputs)	0	—	ns
164	Master data valid (after SCK edge)	—	10	ns
165	Master data hold time (outputs)	0	—	ns
166	Rise time output	—	15	ns
167	Fall time output	—	15	ns

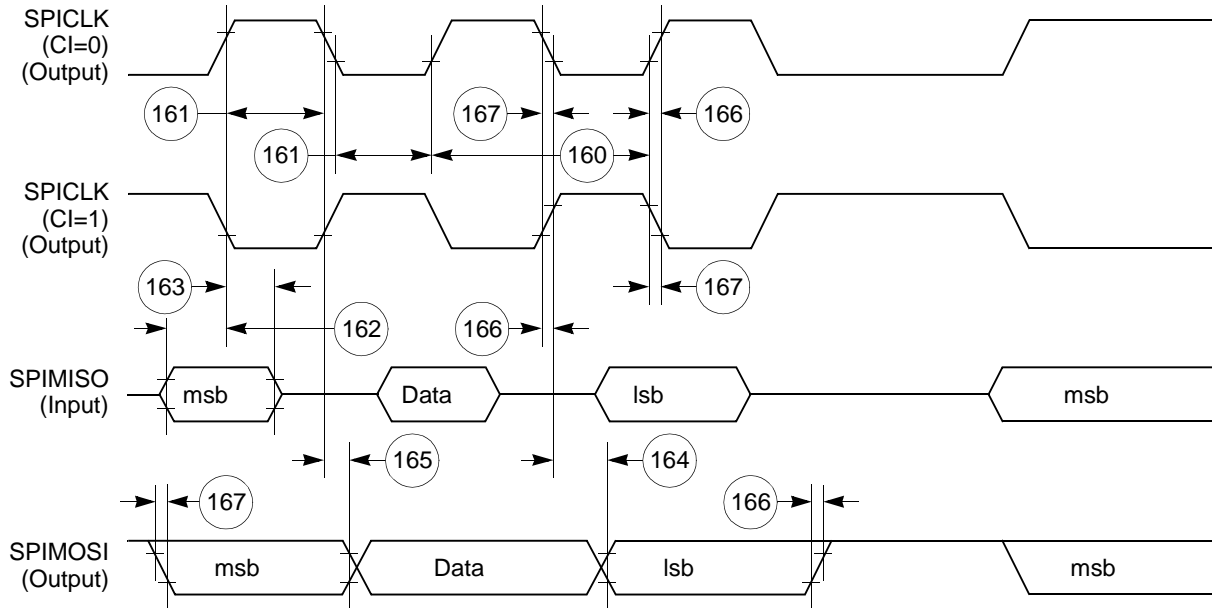

Figure 59. SPI Master (CP = 0) Timing Diagram

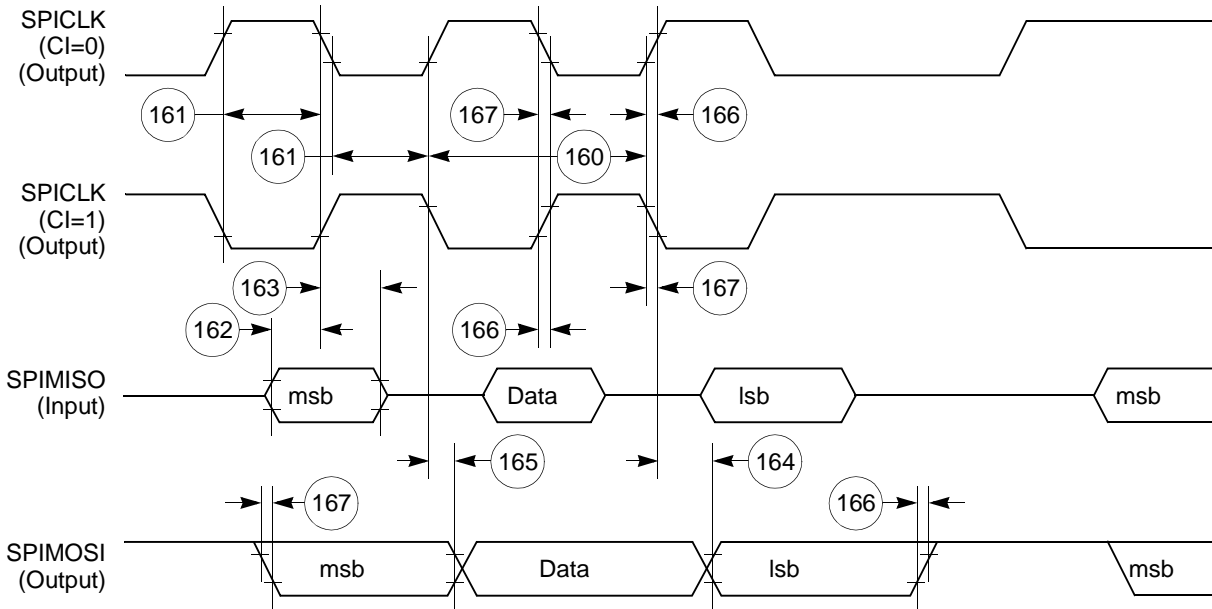

Figure 60. SPI Master (CP = 1) Timing Diagram

13.10 SPI Slave AC Electrical Specifications

Table 27 provides the SPI slave timings as shown in Figure 61 and Figure 62.

Table 27. SPI Slave Timing

Num	Characteristic	All Frequencies		Unit
		Min	Max	
170	Slave cycle time	2	—	t _{cyc}
171	Slave enable lead time	15	—	ns
172	Slave enable lag time	15	—	ns
173	Slave clock (SPICLK) high or low time	1	—	t _{cyc}
174	Slave sequential transfer delay (does not require deselect)	1	—	t _{cyc}
175	Slave data setup time (inputs)	20	—	ns
176	Slave data hold time (inputs)	20	—	ns
177	Slave access time	—	50	ns

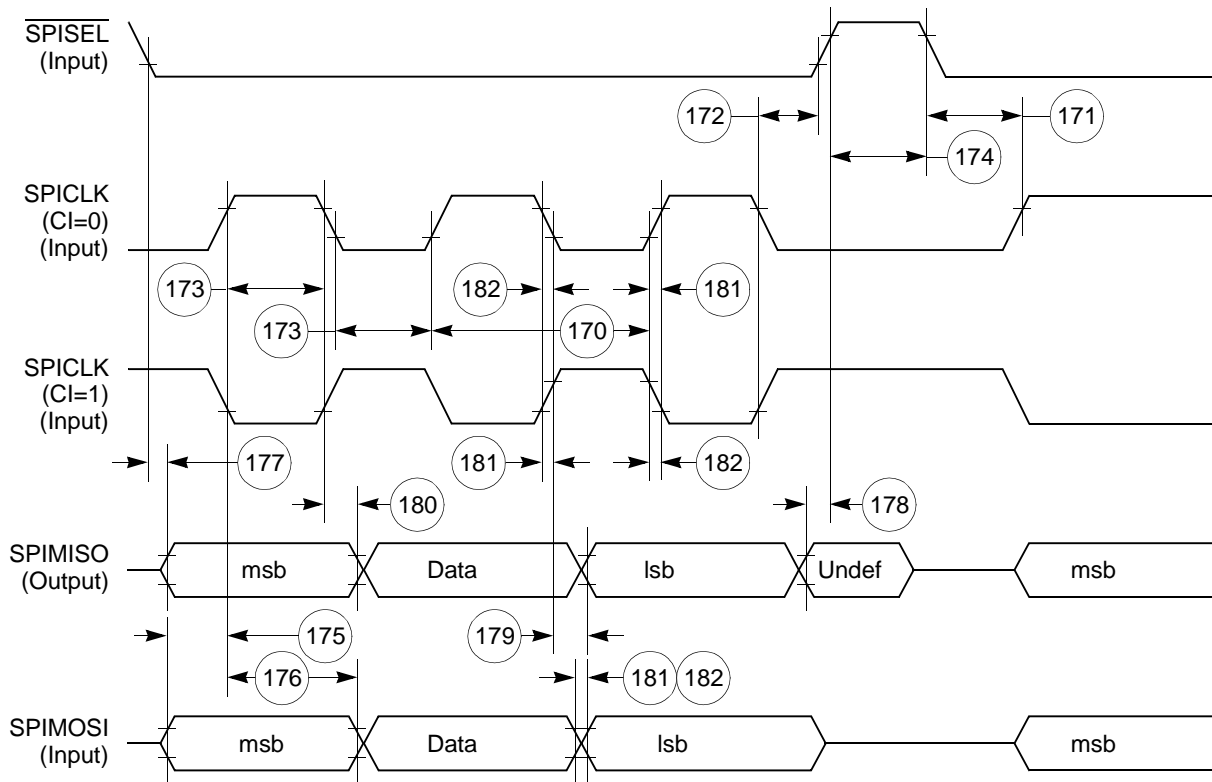

Figure 61. SPI Slave (CP = 0) Timing Diagram

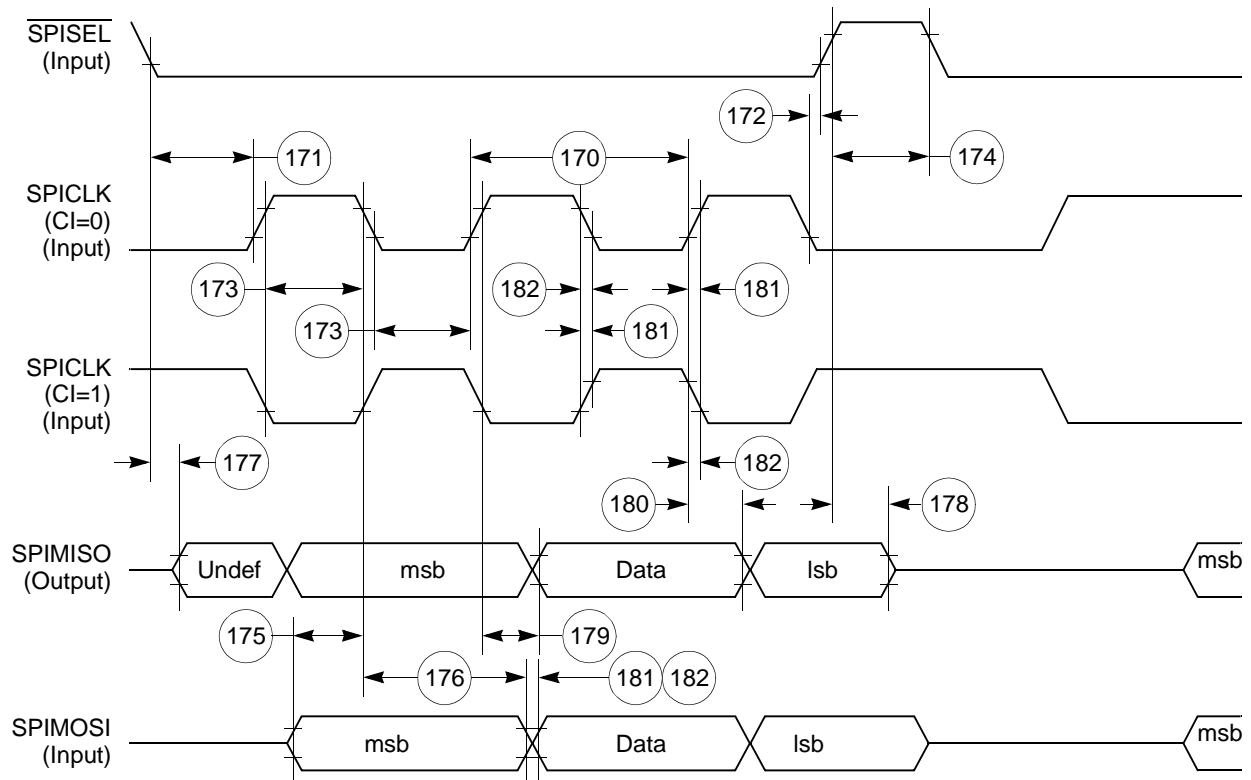

Figure 62. SPI Slave (CP = 1) Timing Diagram

13.11²C AC Electrical Specifications

Table 28 provides the I²C (SCL < 100 KHz) timings.

Table 28. I²C Timing (SCL < 100 KHz)

Num	Characteristic	All Frequencies		Unit
		Min	Max	
200	SCL clock frequency (slave)	0	100	KHz
200	SCL clock frequency (master) ¹	1.5	100	KHz
202	Bus free time between transmissions	4.7	—	μs
203	Low period of SCL	4.7	—	μs
204	High period of SCL	4.0	—	μs
205	Start condition setup time	4.7	—	μs
206	Start condition hold time	4.0	—	μs
207	Data hold time	0	—	μs
208	Data setup time	250	—	ns
209	SDL/SCL rise time	—	1	μs

Table 28. I²C Timing (SCL < 100 KHz) (continued)

Num	Characteristic	All Frequencies		Unit
		Min	Max	
210	SDL/SCL fall time	—	300	ns
211	Stop condition setup time	4.7	—	μs

¹ SCL frequency is given by $SCL = BRGCLK_frequency / ((BRG\ register + 3) \times pre_scalar \times 2)$.
The ratio $SyncClk/(BRGCLK/pre_scalar)$ must be greater than or equal to 4/1.

Table 29 provides the I²C (SCL > 100 KHz) timings.

Table 29. I²C Timing (SCL > 100 KHz)

Num	Characteristic	Expression	All Frequencies		Unit
			Min	Max	
200	SCL clock frequency (slave)	fSCL	0	BRGCLK/48	Hz
200	SCL clock frequency (master) ¹	fSCL	BRGCLK/16512	BRGCLK/48	Hz
202	Bus free time between transmissions	—	1/(2.2 × fSCL)	—	s
203	Low period of SCL	—	1/(2.2 × fSCL)	—	s
204	High period of SCL	—	1/(2.2 × fSCL)	—	s
205	Start condition setup time	—	1/(2.2 × fSCL)	—	s
206	Start condition hold time	—	1/(2.2 × fSCL)	—	s
207	Data hold time	—	0	—	s
208	Data setup time	—	1/(40 × fSCL)	—	s
209	SDL/SCL rise time	—	—	1/(10 × fSCL)	s
210	SDL/SCL fall time	—	—	1/(33 × fSCL)	s
211	Stop condition setup time	—	1/2(2.2 × fSCL)	—	s

¹ SCL frequency is given by $SCL = BrgClk_frequency / ((BRG\ register + 3) \times pre_scalar \times 2)$.
The ratio $SyncClk/(Brg_Clk/pre_scalar)$ must be greater than or equal to 4/1.

USB Electrical Characteristics

Figure 63 shows the I²C bus timing.

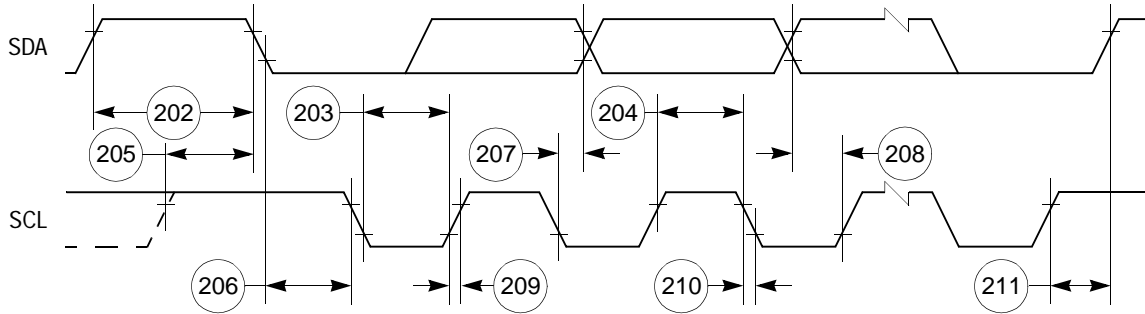

Figure 63. I²C Bus Timing Diagram

14 USB Electrical Characteristics

This section provides the AC timings for the USB interface.

14.1 USB Interface AC Timing Specifications

The USB Port uses the transmit clock on SCC1. Table 30 lists the USB interface timings.

Table 30. USB Interface AC Timing Specifications

Name	Characteristic	All Frequencies		Unit
		Min	Max	
US1	USBCLK frequency of operation ¹ Low speed Full speed	6	48	MHz MHz
US4	USBCLK duty cycle (measured at 1.5 V)	45	55	%

¹ USBCLK accuracy should be ± 500 ppm or better. USBCLK may be stopped to conserve power.

15 FEC Electrical Characteristics

This section provides the AC electrical specifications for the fast Ethernet controller (FEC). Note that the timing specifications for the MII signals are independent of system clock frequency (part speed designation). Also, MII signals use TTL signal levels compatible with devices operating at either 5.0 V or 3.3 V.

15.1 MII and Reduced MII Receive Signal Timing

The receiver functions correctly up to a MII_RX_CLK maximum frequency of 25 MHz + 1%. The reduced MII (RMII) receiver functions correctly up to a RMII_REFCLK maximum frequency of 50 MHz + 1%. There is no minimum frequency requirement. In addition, the processor clock frequency must exceed the MII_RX_CLK frequency - 1%.

Table 31 provides information on the MII receive signal timing.

Table 31. MII Receive Signal Timing

Num	Characteristic	Min	Max	Unit
M1	MII_RXD[3:0], MII_RX_DV, MII_RX_ER to MII_RX_CLK setup	5	—	ns
M2	MII_RX_CLK to MII_RXD[3:0], MII_RX_DV, MII_RX_ER hold	5	—	ns
M3	MII_RX_CLK pulse width high	35%	65%	MII_RX_CLK period
M4	MII_RX_CLK pulse width low	35%	65%	MII_RX_CLK period
M1_R MII	RMII_RXD[1:0], RMII_CRS_DV, RMII_RX_ERR to RMII_REFCLK setup	4	—	ns
M2_R MII	RMII_REFCLK to RMII_RXD[1:0], RMII_CRS_DV, RMII_RX_ERR hold	2	—	ns

Figure 64 shows MII receive signal timing.

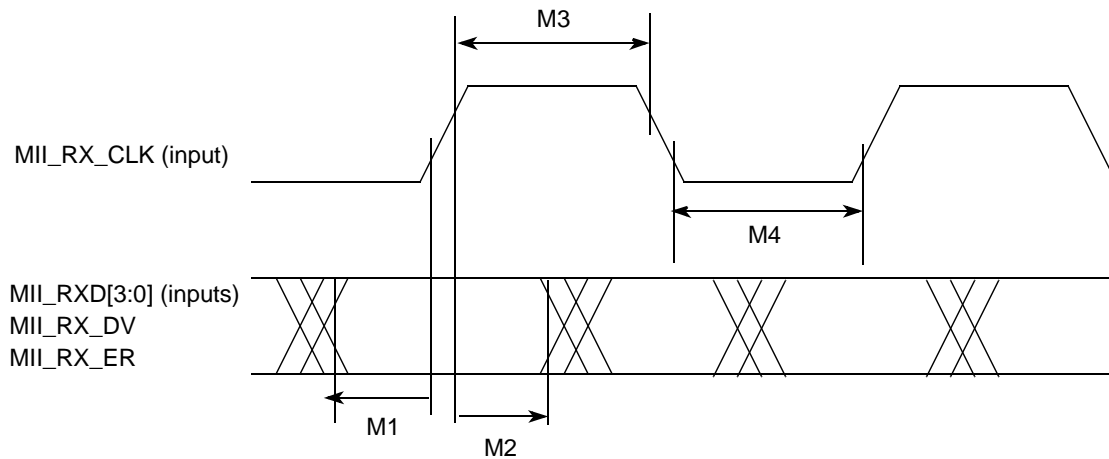

Figure 64. MII Receive Signal Timing Diagram

15.2 MII and Reduced MII Transmit Signal Timing

The transmitter functions correctly up to a MII_TX_CLK maximum frequency of 25 MHz + 1%. There is no minimum frequency requirement. In addition, the processor clock frequency must exceed the MII_TX_CLK frequency – 1%.

Table 32 provides information on the MII transmit signal timing.

Table 32. MII Transmit Signal Timing

Num	Characteristic	Min	Max	Unit
M5	MII_TX_CLK to MII_TXD[3:0], MII_TX_EN, MII_TX_ER invalid	5	—	ns
M6	MII_TX_CLK to MII_TXD[3:0], MII_TX_EN, MII_TX_ER valid	—	25	ns
M7	MII_TX_CLK pulse width high	35%	65%	MII_TX_CLK period
M8	MII_TX_CLK pulse width low	35%	65%	MII_TX_CLK period

Table 32. MII Transmit Signal Timing (continued)

Num	Characteristic	Min	Max	Unit
M20_R MII	RMII_TXD[1:0], RMII_TX_EN to RMII_REFCLK setup	4	—	ns
M21_R MII	RMII_TXD[1:0], RMII_TX_EN data hold from RMII_REFCLK rising edge	2	—	ns

Figure 65 shows the MII transmit signal timing diagram.

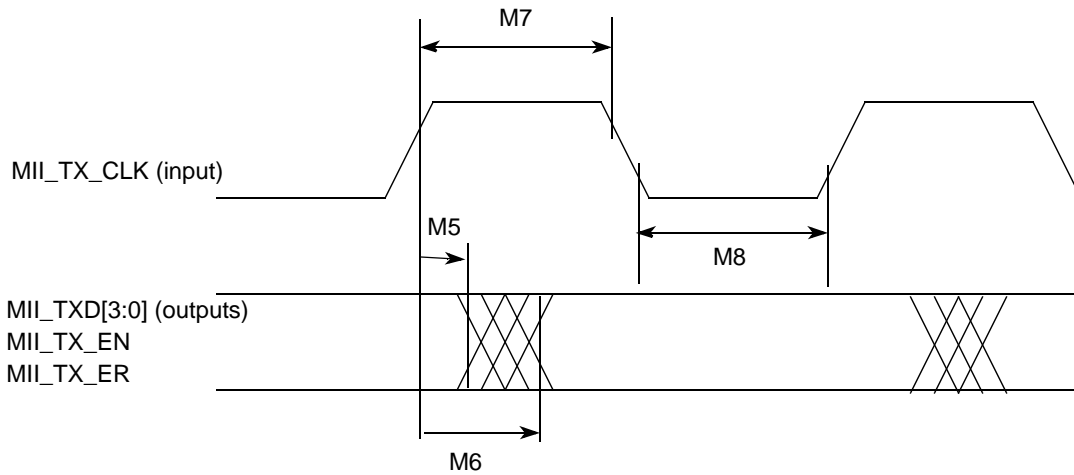

Figure 65. MII Transmit Signal Timing Diagram

15.3 MII Async Inputs Signal Timing (MII_CRIS, MII_COL)

Table 33 provides information on the MII async inputs signal timing.

Table 33. MII Async Inputs Signal Timing

Num	Characteristic	Min	Max	Unit
M9	MII_CRIS, MII_COL minimum pulse width	1.5	—	MII_TX_CLK period

Figure 66 shows the MII asynchronous inputs signal timing diagram.

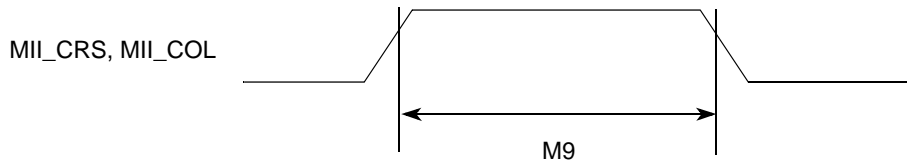

Figure 66. MII Async Inputs Timing Diagram

15.4 MII Serial Management Channel Timing (MII_MDIO, MII_MDC)

Table 34 provides information on the MII serial management channel signal timing. The FEC functions correctly with a maximum MDC frequency in excess of 2.5 MHz. The exact upper bound is under investigation.

Table 34. MII Serial Management Channel Timing

Num	Characteristic	Min	Max	Unit
M10	MII_MDC falling edge to MII_MDIO output invalid (minimum propagation delay)	0	—	ns
M11	MII_MDC falling edge to MII_MDIO output valid (max prop delay)	—	25	ns
M12	MII_MDIO (input) to MII_MDC rising edge setup	10	—	ns
M13	MII_MDIO (input) to MII_MDC rising edge hold	0	—	ns
M14	MII_MDC pulse width high	40%	60%	MII_MDC period
M15	MII_MDC pulse width low	40%	60%	MII_MDC period

Figure 67 shows the MII serial management channel timing diagram.

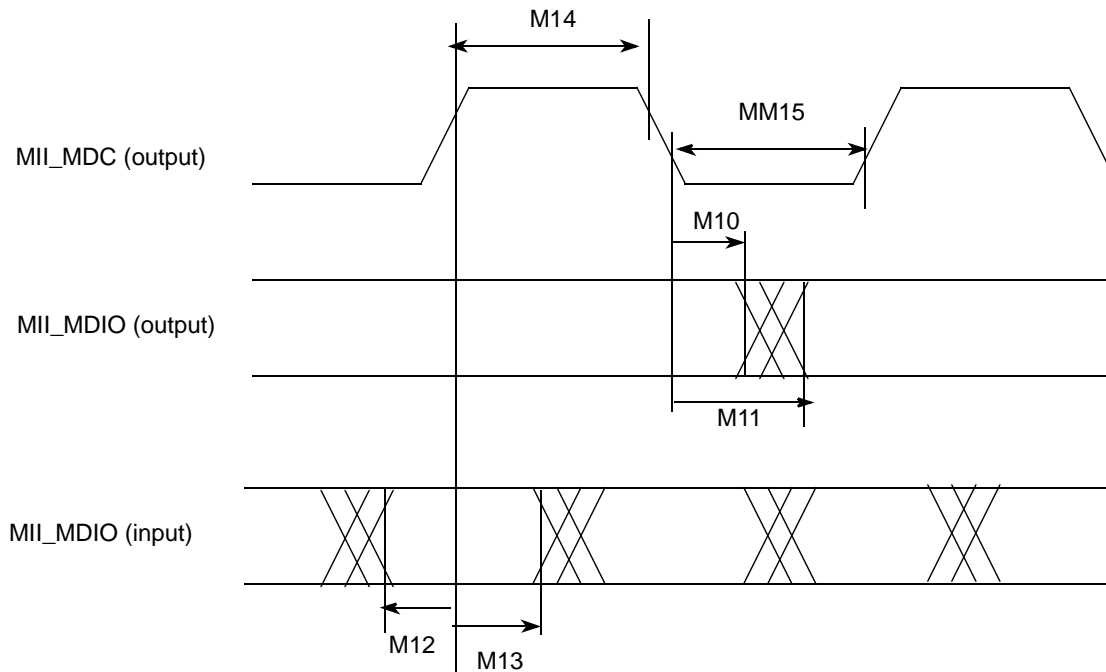

Figure 67. MII Serial Management Channel Timing Diagram

16 Mechanical Data and Ordering Information

Table 35 identifies the packages and operating frequencies available for the MPC875/870.

Table 35. Available MPC875/870 Packages/Frequencies

Package Type	Temperature (Tj)	Frequency (MHz)	Order Number
Plastic ball grid array ZT suffix — Leaded VR suffix — Lead-Free are available as needed	0°C to 95°C	66	KMPC875ZT66 KMPC870ZT66 MPC875ZT66 MPC870ZT66
		80	KMPC875ZT80 KMPC870ZT80 MPC875ZT80 MPC870ZT80
		133	KMPC875ZT133 KMPC870ZT133 MPC875ZT133 MPC870ZT133
Plastic ball grid array CZT suffix — Leaded CVR suffix — Lead-Free are available as needed	-40°C to 100°C	66	KMPC875CZT66 KMPC870CZT66 MPC875CZT66 MPC870CZT66
		133	KMPC875CZT133 KMPC870CZT133 MPC875CZT133 MPC870CZT133

16.1 Pin Assignments

Figure 68 shows the JEDEC pinout of the PBGA package as viewed from the top surface. For additional information, see the *MPC885 PowerQUICC Family User's Manual*.

NOTE

The pin numbering starts with B2 in order to conform to the JEDEC standard for 23-mm body size using a 16 × 16 array.

NOTE: This is the top view of the device.

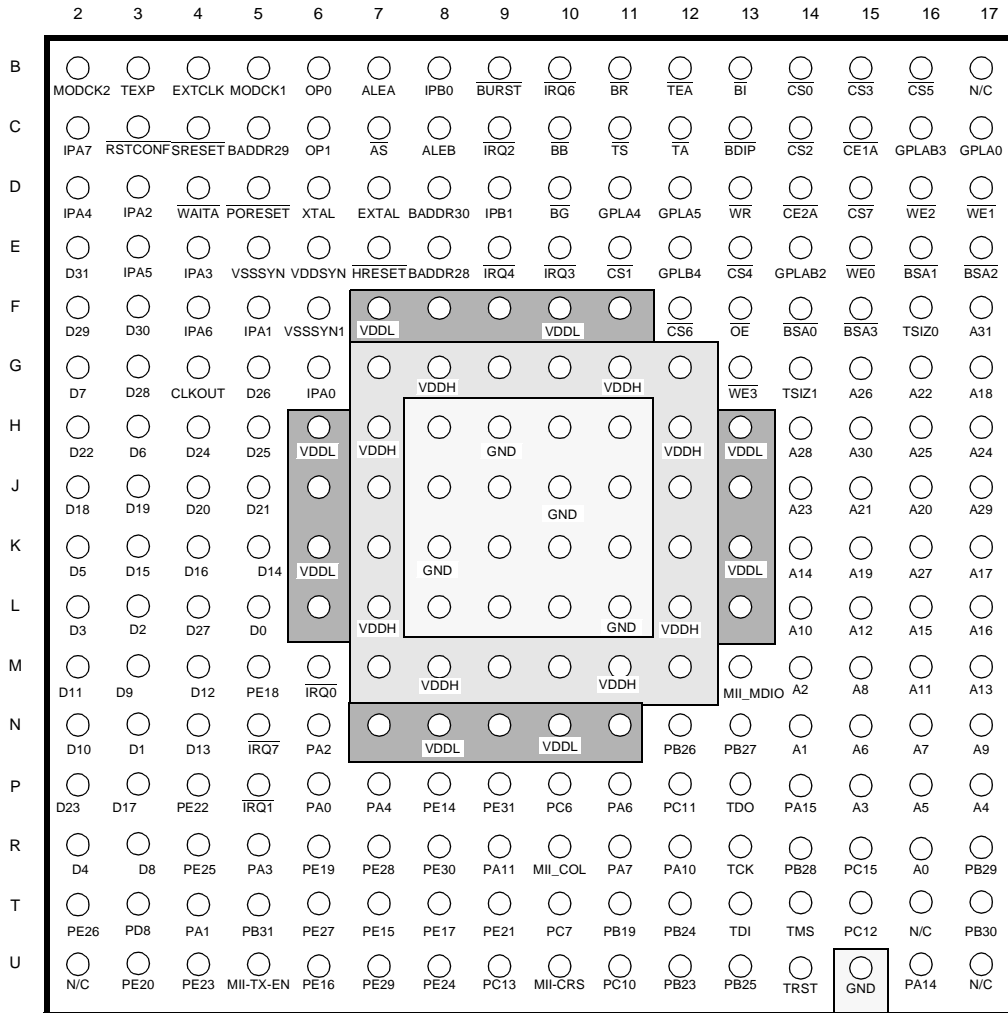

Figure 68. Pinout of the PBGA Package—JEDEC Standard

Table 36 contains a list of the MPC875/870 input and output signals and shows multiplexing and pin assignments.

Table 36. Pin Assignments—JEDEC Standard

Name	Pin Number	Type
A[0:31]	R16, N14, M14, P15, P17, P16, N15, N16, M15, N17, L14, M16, L15, M17, K14, L16, L17, K17, G17, K15, J16, J15, G16, J14, H17, H16, G15, K16, H14, J17, H15, F17	Bidirectional Three-state (3.3 V only)
TSIZ0 REG	F16	Bidirectional Three-state (3.3 V only)

Table 36. Pin Assignments—JEDEC Standard (continued)

Name	Pin Number	Type
TSIZ1	G14	Bidirectional Three-state (3.3 V only)
$\overline{RD/WR}$	D13	Bidirectional Three-state (3.3 V only)
\overline{BURST}	B9	Bidirectional Three-state (3.3 V only)
\overline{BDIP} $\overline{GPL_B5}$	C13	Output
\overline{TS}	C11	Bidirectional Active pull-up (3.3 V only)
\overline{TA}	C12	Bidirectional Active pull-up (3.3 V only)
\overline{TEA}	B12	Open-drain
\overline{BI}	B13	Bidirectional Active pull-up (3.3 V only)
$\overline{IRQ2}$ \overline{RSV}	C9	Bidirectional Three-state (3.3 V only)
$\overline{IRQ4}$ \overline{KR} \overline{RETRY} SPKROUT	E9	Bidirectional Three-state (3.3 V only)
D[0:31]	L5, N3, L3, L2, R2, K2, H3, G2, R3, M3, N2, M2, M4, N4, K5, K3, K4, P3, J2, J3, J4, J5, H2, P2, H4, H5, G5, L4, G3, F2, F3, E2	Bidirectional Three-state (3.3 V only)
\overline{CR} $\overline{IRQ3}$	E10	Input
\overline{FRZ} $\overline{IRQ6}$	B10	Bidirectional Three-state (3.3 V only)
\overline{BR}	B11	Bidirectional (3.3 V only)
\overline{BG}	D10	Bidirectional (3.3 V only)
\overline{BB}	C10	Bidirectional Active pull-up (3.3 V only)
$\overline{IRQ0}$	M6	Input (3.3 V only)
$\overline{IRQ1}$	P5	Input (3.3 V only)
$\overline{IRQ7}$	N5	Input (3.3 V only)
$\overline{CS}[0:5]$	B14, E11, C14, B15, E13, B16	Output
$\overline{CS6}$ $\overline{CE1_B}$	F12	Output
$\overline{CS7}$ $\overline{CE2_B}$	D15	Output

Table 36. Pin Assignments—JEDEC Standard (continued)

Name	Pin Number	Type
$\overline{\text{WE0}}$ $\overline{\text{BS_B0}}$ $\overline{\text{IORD}}$	E15	Output
$\overline{\text{WE1}}$ $\overline{\text{BS_B1}}$ $\overline{\text{IOWR}}$	D17	Output
$\overline{\text{WE2}}$ $\overline{\text{BS_B2}}$ $\overline{\text{PCOE}}$	D16	Output
$\overline{\text{WE3}}$ $\overline{\text{BS_B3}}$ $\overline{\text{PCWE}}$	G13	Output
$\overline{\text{BS_A[0:3]}}$	F14, E16, E17, F15	Output
$\overline{\text{GPL_A0}}$ $\overline{\text{GPL_B0}}$	C17	Output
$\overline{\text{OE}}$ $\overline{\text{GPL_A1}}$ $\overline{\text{GPL_B1}}$	F13	Output
$\overline{\text{GPL_A[2:3]}}$ $\overline{\text{GPL_B[2:3]}}$ $\overline{\text{CS[2-3]}}$	E14, C16	Output
$\overline{\text{UPWAITA}}$ $\overline{\text{GPL_A4}}$	D11	Bidirectional (3.3 V only)
$\overline{\text{UPWAITB}}$ $\overline{\text{GPL_B4}}$	E12	Bidirectional
$\overline{\text{GPL_A5}}$	D12	Output
$\overline{\text{PORESET}}$	D5	Input (3.3 V only)
$\overline{\text{RSTCONF}}$	C3	Input (3.3 V only)
$\overline{\text{HRESET}}$	E7	Open-drain
$\overline{\text{SRESET}}$	C4	Open-drain
XTAL	D6	Analog output
EXTAL	D7	Analog input (3.3 V only)
CLKOUT	G4	Output
EXTCLK	B4	Input (3.3 V only)
TEXP	B3	Output
ALE_A	B7	Output
$\overline{\text{CE1_A}}$	C15	Output
$\overline{\text{CE2_A}}$	D14	Output
$\overline{\text{WAIT_A}}$	D4	Input (3.3 V only)

Table 36. Pin Assignments—JEDEC Standard (continued)

Name	Pin Number	Type
IP_A0	G6	Input (3.3 V only)
IP_A1	F5	Input (3.3 V only)
IP_A2 IOIS16_A	D3	Input (3.3 V only)
IP_A3	E4	Input (3.3 V only)
IP_A4	D2	Input (3.3 V only)
IP_A5	E3	Input (3.3 V only)
IP_A6	F4	Input (3.3 V only)
IP_A7	C2	Input (3.3 V only)
ALE_B DSCK	C8	Bidirectional Three-state (3.3 V only)
IP_B[0:1] IWP[0:1] VFLS[0:1]	B8, D9	Bidirectional (3.3 V only)
OP0	B6	Bidirectional (3.3 V only)
OP1	C6	Output
OP2 MODCK1 STS	B5	Bidirectional (3.3 V only)
OP3 MODCK2 DSDO	B2	Bidirectional (3.3 V only)
BADDR[28:29]	E8, C5	Output
BADDR30 REG	D8	Output
\overline{AS}	C7	Input (3.3 V only)
PA15 USBRXD	P14	Bidirectional
PA14 USBOE	U16	Bidirectional (Optional: open-drain)
PA11 RXD4 MII1-TXD0 RMII1-TXD0	R9	Bidirectional (Optional: open-drain) (5-V tolerant)
PA10 MII1-TXERR TIN4 CLK7	R12	Bidirectional (Optional: open-drain) (5-V tolerant)

Table 36. Pin Assignments—JEDEC Standard (continued)

Name	Pin Number	Type
PA7 CLK1 BRGO1 TIN1	R11	Bidirectional
PA6 CLK2 TOUT1	P11	Bidirectional
PA4 CTS4 MII1-TXD1 RMII-TXD1	P7	Bidirectional
PA3 MII1-RXER RMII1-RXER BRGO3	R5	Bidirectional (5-V tolerant)
PA2 MII1-RXDV RMII1-CRS_DV TXD4	N6	Bidirectional (5-V tolerant)
PA1 MII1-RXD0 RMII1-RXD0 BRGO4	T4	Bidirectional (5-V tolerant)
PA0 MII1-RXD1 RMII1-RXD1 TOUT4	P6	Bidirectional (5-V tolerant)
PB31 SPISEL MII1 - TXCLK RMII1-REFCLK	T5	Bidirectional (Optional: open-drain) (5-V tolerant)
PB30 SPICLK	T17	Bidirectional (Optional: open-drain) (5-V tolerant)
PB29 SPIMOSI	R17	Bidirectional (Optional: open-drain) (5-V tolerant)
PB28 SPIMISO BRGO4	R14	Bidirectional (Optional: open-drain) (5-V tolerant)
PB27 I2CSDA BRGO1	N13	Bidirectional (Optional: open-drain)
PB26 I2CSCL BRGO2	N12	Bidirectional (Optional: open-drain)

Table 36. Pin Assignments—JEDEC Standard (continued)

Name	Pin Number	Type
PB25 SMTXD1	U13	Bidirectional (Optional: open-drain) (5-V tolerant)
PB24 SMRXD1	T12	Bidirectional (Optional: open-drain) (5-V tolerant)
PB23 SDACK1 SMSYN1	U12	Bidirectional (Optional: open-drain)
PB19 MII1-RXD3 RTS4	T11	Bidirectional (Optional: open-drain)
PC15 DREQ0 L1ST1	R15	Bidirectional (5-V tolerant)
PC13 MII1-TXD3 SDACK1	U9	Bidirectional (5-V tolerant)
PC12 MII1-TXD2 TOUT1	T15	Bidirectional (5-V tolerant)
PC11 USBRXP	P12	Bidirectional
PC10 USBRXN TGATE1	U11	Bidirectional
PC7 CTS4 L1TSYNCB USBTXP	T10	Bidirectional (5-V tolerant)
PC6 CD4 L1RSYNCB USBTXN	P10	Bidirectional (5-V tolerant)
PD8 RXD4 MII-MDC RMII-MDC	T3	Bidirectional (5-V tolerant)
PE31 CLK8 L1TCLKB MII1-RXCLK	P9	Bidirectional (Optional: open-drain)
PE30 L1RXDB MII1-RXD2	R8	Bidirectional (Optional: open-drain)

Table 36. Pin Assignments—JEDEC Standard (continued)

Name	Pin Number	Type
PE29 MII2-CRS	U7	Bidirectional (Optional: open-drain)
PE28 TOUT3 MII2-COL	R7	Bidirectional (Optional: open-drain)
PE27 L1RQB MII2-RXERR RMII2-RXERR	T6	Bidirectional (Optional: open-drain)
PE26 L1CLKOB MII2-RXDV RMII2-CRS_DV	T2	Bidirectional (Optional: open-drain)
PE25 RXD4 MII2-RXD3 L1ST2	R4	Bidirectional (Optional: open-drain)
PE24 SMRXD1 BRGO1 MII2-RXD2	U8	Bidirectional (Optional: open-drain)
PE23 TXD4 MII2-RXCLK L1ST1	U4	Bidirectional (Optional: open-drain)
PE22 TOUT2 MII2-RXD1 RMII2-RXD1 SDACK1	P4	Bidirectional (Optional: open-drain)
PE21 TOUT1 MII2-RXD0 RMII2-RXD0	T9	Bidirectional (Optional: open-drain)
PE20 MII2-TXER	U3	Bidirectional (Optional: open-drain)
PE19 L1TXDB MII2-TXEN RMII2-TXEN	R6	Bidirectional (Optional: open-drain)
PE18 SMTXD1 MII2-TXD3	M5	Bidirectional (Optional: open-drain)

Table 36. Pin Assignments—JEDEC Standard (continued)

Name	Pin Number	Type
PE17 TIN3 CLK5 BRGO3 SMSYN1 MII2-TXD2	T8	Bidirectional (Optional: open-drain)
PE16 L1RCLKB CLK6 MII2-TXCLK RMII2-REFCLK	U6	Bidirectional (Optional: open-drain)
PE15 TGATE1 MII2-TXD1 RMII2-TXD1	T7	Bidirectional
PE14 MII2-TXD0 RMII2-TXD0	P8	Bidirectional
TMS	T14	Input (5-V tolerant)
TDI DSDI	T13	Input (5-V tolerant)
TCK DSCK	R13	Input (5-V tolerant)
TRST	U14	Input (5-V tolerant)
TDO DSDO	P13	Output (5-V tolerant)
MII1_CRS	U10	Input
MII_MDIO	M13	Bidirectional (5-V tolerant)
MII1_TX_EN RMII1_TX_EN	U5	Output (5-V tolerant)
MII1_COL	R10	Input
V _{SS} SYN	E5	PLL analog GND
V _{SS} SYN1	F6	PLL analog GND
V _{DD} SYN	E6	PLL analog V _{DD}
GND	H8, H9, H10, H11, J8, J9, J10, J11, K8, K9, K10, K11, L8, L9, L10, L11, U15	Power
V _{DDL}	F7, F8, F9, F10, F11, H6, H13, J6, J13, K6, K13, L6, L13, N7, N8, N9, N10, N11	Power

Table 36. Pin Assignments—JEDEC Standard (continued)

Name	Pin Number	Type
V _{DDH}	G7, G8, G9, G10, G11, G12, H7, H12, J7, J12, K7, K12, L7, L12, M7, M8, M9, M10, M11, M12	Power
N/C	B17, T16, U2, U17	No-connect

16.2 Mechanical Dimensions of the PBGA Package

Figure 69 shows the mechanical dimensions of the PBGA package.

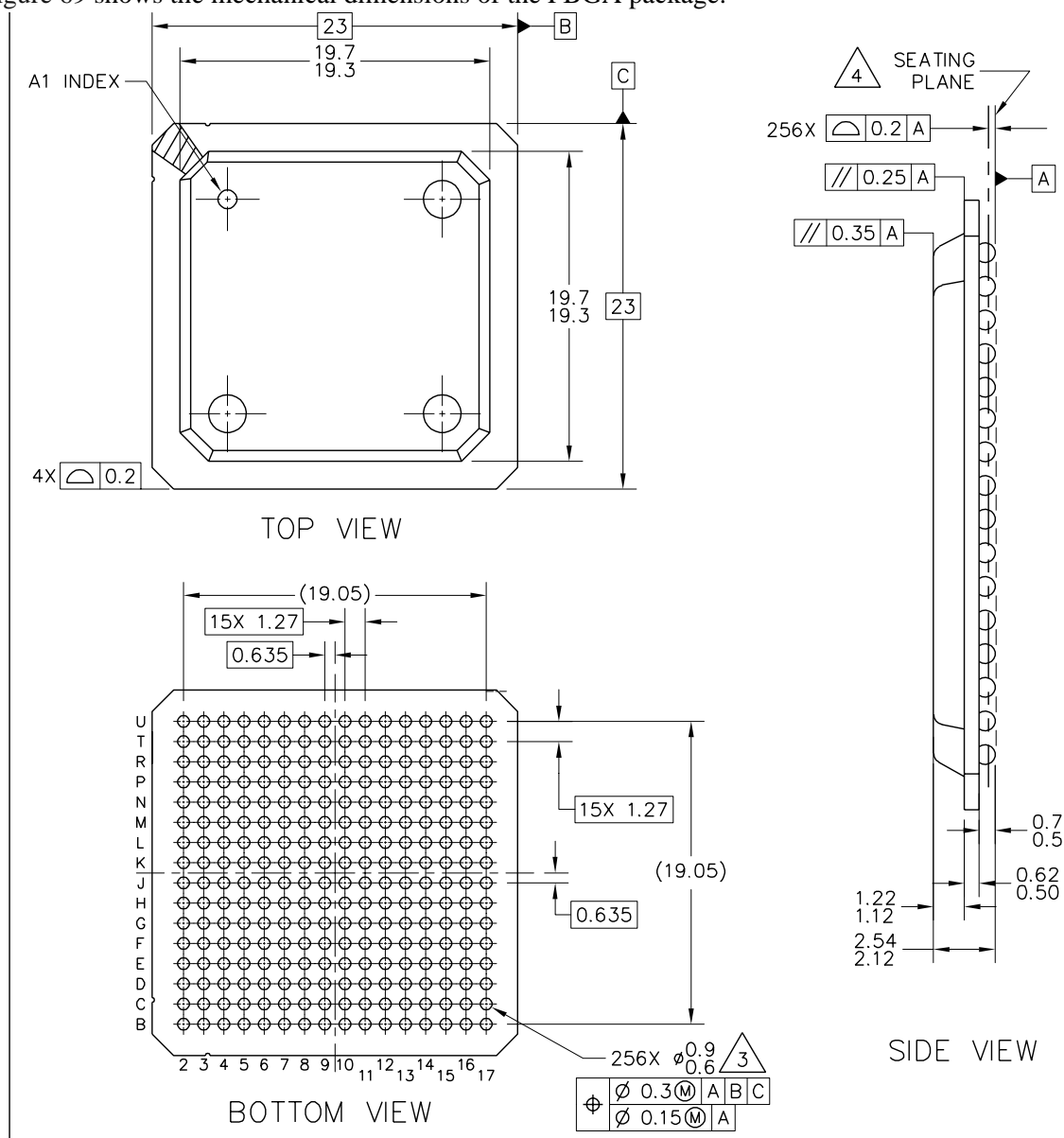

Figure 69. Mechanical Dimensions and Bottom Surface Nomenclature of the PBGA Package

17 Document Revision History

Table 37 lists significant changes between revisions of this hardware specification.

Table 37. Document Revision History

Revision Number	Date	Changes
0	2/2003	Initial release.
0.1	3/2003	Took out the time-slot assigner and changed the SCC for SCC3 to SCC4.
0.2	5/2003	Changed the package drawing, removed all references to Data Parity. Changed the SPI Master Timing Specs. 162 and 164. Added the RMI and USB timing. Added the 80-MHz timing.
0.3	5/2003	Made sure the pin types were correct. Changed the Features list to agree with the MPC885.
0.4	5/2003	Corrected the signals that had overlines on them. Made corrections on two pins that were typos.
0.5	5/2003	Changed the pin descriptions for PD8 and PD9.
0.6	5/2003	Changed a few typos. Put back the I2C. Put in the new reset configuration, corrected the USB timing.
0.7	6/2003	Changed the pin descriptions per the June 22 spec, removed Utopia from the pin descriptions, changed PADIR, PBDIR, PCDIR and PDDIR to be 0 in the Mandatory Reset Config.
0.8	8/2003	Added the reference to USB 2.0 to the Features list and removed 1.1 from USB on the block diagrams.
0.9	8/2003	Changed the USB description to full-/low-speed compatible.
1.0	9/2003	Added the DSP information in the Features list. Put a new sentence under Mechanical Dimensions. Fixed table formatting. Nontechnical edits. Released to the external web.
1.1	10/2003	Added TDm to the MPC875 Features list, the MPC875 Block Diagram, added 13.5 Serial Interface AC Electrical Specifications, and removed TDMA from the pin descriptions.

Table 37. Document Revision History (continued)

Revision Number	Date	Changes
2.0	12/2003	<p>Changed DBGC in the Mandatory Reset Configuration to X1. Changed the maximum operating frequency to 133 MHz. Put the timing in the 80 MHz column. Put in the orderable part numbers. Rounded the timings to hundredths in the 80 MHz column. Put the pin numbers in footnotes by the maximum currents in Table 6. Changed 22 and 41 in the Timing. Put TBD in the Thermal table.</p>
3.0	1/07/2004 7/19/2004	<ul style="list-style-type: none"> • Added sentence to Spec B1A about EXTCLK and CLKOUT being in Alignment for Integer Values • Added a footnote to Spec 41 specifying that EDM = 1 • Added the thermal numbers to Table 4. • Added RMII1_EN under M1II_EN in Table 36 Pin Assignments • Added a tablefootnote to Table 6 DC Electrical Specifications about meeting the VIL Max of the I2C Standard • Put the new part numbers in the Ordering Information Section

How to Reach Us:

USA/Europe/Locations Not Listed:

Freescale Semiconductor
Literature Distribution Center
P.O. Box 5405,
Denver, Colorado 80217
1-480-768-2130
(800) 521-6274

Japan:

Freescale Semiconductor Japan Ltd.
Technical Information Center
3-20-1, Minami-Azabu, Minato-ku
Tokyo 106-8573, Japan
81-3-3440-3569

Asia/Pacific:

Freescale Semiconductor Hong Kong Ltd.
2 Dai King Street
Tai Po Industrial Estate
Tai Po, N.T. Hong Kong
852-26668334

Home Page:

www.freescale.com

Information in this document is provided solely to enable system and software implementers to use Freescale Semiconductor products. There are no express or implied copyright licenses granted hereunder to design or fabricate any integrated circuits or integrated circuits based on the information in this document.

Freescale Semiconductor reserves the right to make changes without further notice to any products herein. Freescale Semiconductor makes no warranty, representation or guarantee regarding the suitability of its products for any particular purpose, nor does Freescale Semiconductor assume any liability arising out of the application or use of any product or circuit, and specifically disclaims any and all liability, including without limitation consequential or incidental damages. "Typical" parameters which may be provided in Freescale Semiconductor data sheets and/or specifications can and do vary in different applications and actual performance may vary over time. All operating parameters, including "Typicals" must be validated for each customer application by customer's technical experts. Freescale Semiconductor does not convey any license under its patent rights nor the rights of others. Freescale Semiconductor products are not designed, intended, or authorized for use as components in systems intended for surgical implant into the body, or other applications intended to support or sustain life, or for any other application in which the failure of the Freescale Semiconductor product could create a situation where personal injury or death may occur. Should Buyer purchase or use Freescale Semiconductor products for any such unintended or unauthorized application, Buyer shall indemnify and hold Freescale Semiconductor and its officers, employees, subsidiaries, affiliates, and distributors harmless against all claims, costs, damages, and expenses, and reasonable attorney fees arising out of, directly or indirectly, any claim of personal injury or death associated with such unintended or unauthorized use, even if such claim alleges that Freescale Semiconductor was negligent regarding the design or manufacture of the part.

Learn More: For more information about Freescale Semiconductor products, please visit www.freescale.com

Freescale™ and the Freescale logo are trademarks of Freescale Semiconductor, Inc. The described product contains a PowerPC processor core. The PowerPC name is a trademark of IBM Corp. and used under license. All other product or service names are the property of their respective owners.

© Freescale Semiconductor, Inc. 2004.

MPC875EC
Rev. 3.0
07/2004

PRELIMINARY—SUBJECT TO CHANGE WITHOUT NOTICE

