



SB801G THRU SB807G

Single Phase 8.0 AMPS. Glass Passivated Bridge Rectifiers



Voltage Range
50 to 1000 Volts
Current
8.0 Amperes

Features

- ✧ UL Recognized File # E-96005
- ✧ Glass passivated junction
- ✧ Surge overload rating 175 amperes peak
- ✧ Low forward voltage drop
- ✧ High temperature soldering guaranteed:
260°C / 10 seconds / 0.375" (9.5mm)
lead length at 5 lbs., (2.3 kg) tension
- ✧ Small size, simple installation
- ✧ Leads solderable per MIL-STD-202
Method 208

SB-10

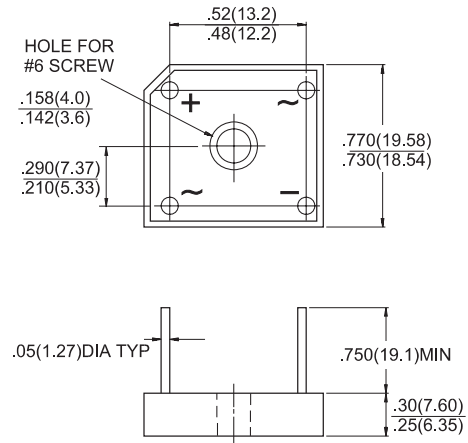

Dimensions in inches and (millimeters)

Maximum Ratings and Electrical Characteristics

Rating at 25°C ambient temperature unless otherwise specified.
 Single phase, half wave, 60 Hz, resistive or inductive load.
 For capacitive load, derate current by 20%

Type Number	Symbol	SB	SB	SB	SB	SB	SB	SB	Units
		801G	802G	803G	804G	805G	806G	807G	
Maximum Recurrent Peak Reverse Voltage	V_{RRM}	50	100	200	400	600	800	1000	V
Maximum RMS Voltage	V_{RMS}	35	70	140	280	420	560	700	V
Maximum DC Blocking Voltage	V_{DC}	50	100	200	400	600	800	1000	V
Maximum Average Forward Rectified Current @ $T_A = 50^\circ\text{C}$	$I_{(AV)}$	8.0							A
Peak Forward Surge Current, 8.3 ms Single Half Sine-wave Superimposed on Rated Load (JEDEC method)	I_{FSM}	175							A
Maximum Instantaneous Forward Voltage @ 4.0A	V_F	1.1							V
Maximum DC Reverse Current @ $T_A=25^\circ\text{C}$ at Rated DC Blocking Voltage @ $T_A=125^\circ\text{C}$	I_R	5 500							μA μA
Typical Thermal Resistance (Note)	$R\theta_{JC}$	6							$^\circ\text{C}/\text{W}$
Operating Temperature Range	T_J	-55 to +150							$^\circ\text{C}$
Storage Temperature Range	T_{STG}	-55 to +150							$^\circ\text{C}$

Note: Thermal Resistance from Junction to Case per Leg.

RATINGS AND CHARACTERISTIC CURVES (SB801G THRU SB807G)

FIG.1- MAXIMUM NON-REPETITIVE FORWARD SURGE CURRENT PER BRIDGE ELEMENT

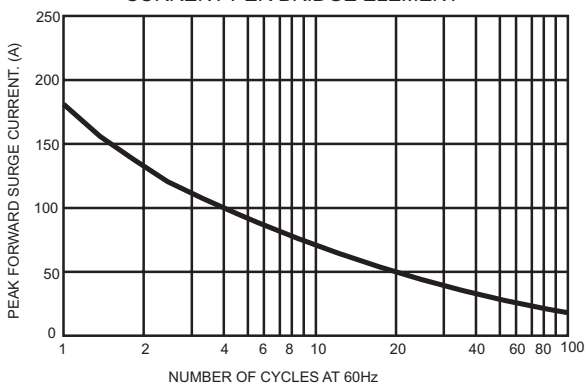

FIG.2- MAXIMUM FORWARD CURRENT DERATING CURVE

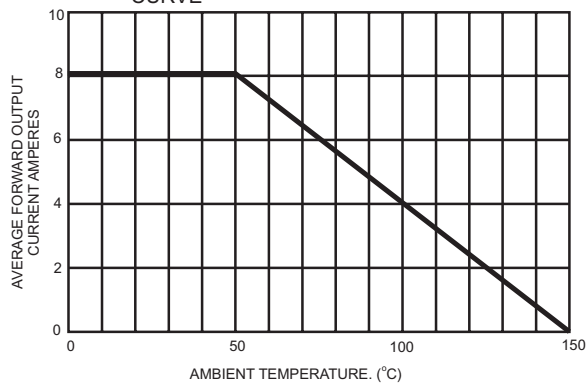

FIG.3- TYPICAL FORWARD CHARACTERISTICS PER BRIDGE ELEMENT

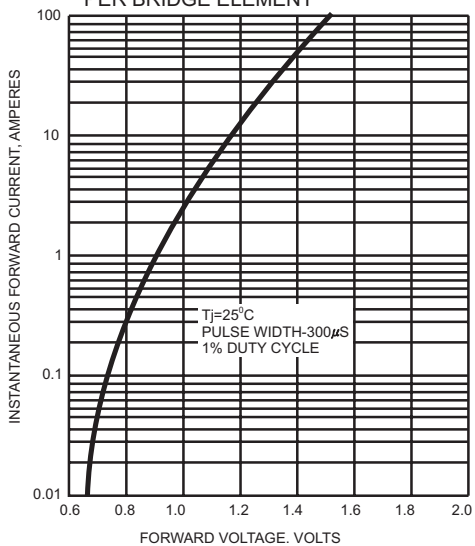

FIG.4- TYPICAL REVERSE CHARACTERISTICS PER BRIDGE ELEMENT

