

High Speed LAN Interface Module

- Features**
- Complies with or exceeds IEEE 802.3, 10BT/100BX requirements
 - Fully functional with 8 mA DC Bias
 - Developed under ISO 9000 provisions
 - Construction withstands IR/VP processes
 - Optimized for 155 Mbps applications

PCA Part Number(s)		EPF8041 & EPF8041G			
Electrical Specifications @ 25°C					
Parameter	Frequency	Specification	XMIT	RCV	Unit
Insertion Loss	1-100 MHz	Under Matched Condition	-1.0	-1.0	dB Max.
Isolation		1500 (for 1 minute)			Vrms
Return Loss	5-10 MHz	(See Note 1)	-20	-20	dB Min.
Return Loss	10-100 MHz	(See Note 1)	-12	-12	dB Min.
Common Mode Rejection	30-100 MHz		-45	-30	dB Min.
Crosstalk	1-100 MHz	Between Channels	-40	-40	dB Min.
OCL (Specified DC Bias)	100 KHz, 0.1V	Across 1-2 and 15-16 (See Note 2)	350	350	µH Min.
Impedance Ratio			100:100	100:100	

Notes : 1. @ pins 8-7 ; pins 1-2 terminated with 100 .
 @ pins 9-10 ; pins 16-15 terminated with 100 .
 2. 8 mA DC Bias

Schematic

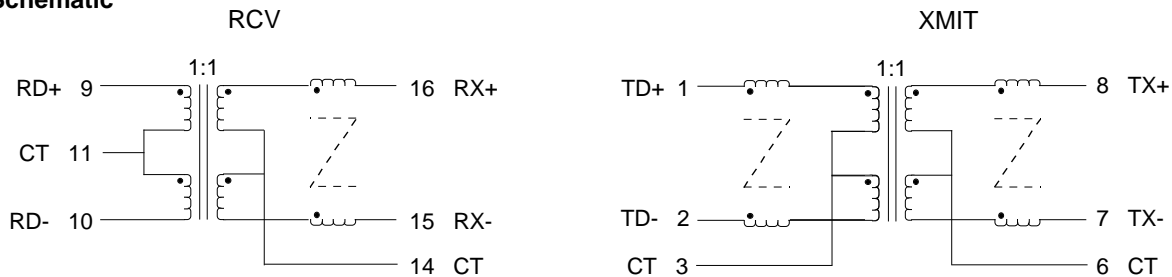

Package

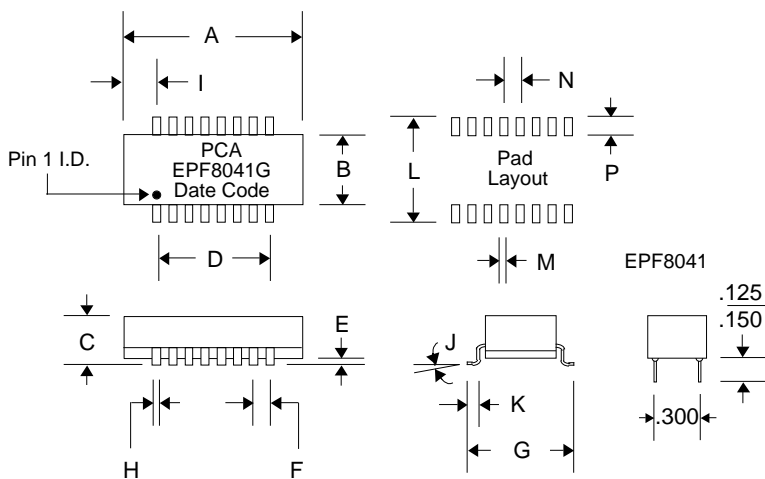

Dimensions

Dim.	(In Inches)		
	Min.	Max.	Nom.
A	.970	.990	
B	.380	.400	
C	.223	.243	
D	.700	Typ.	
E	.003	.020	
F	.100	Typ.	
G	.500	.520	
H	.015	.021	
I	.090	Typ.	
J	0°	8°	
K	.025	.045	
L			.560
M			.030
N			.100
P			.092