

10/100Base-TX Interface Module for NIC/HUB Applications

EPF8024G

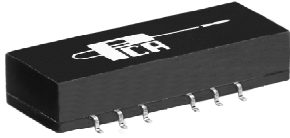

- Optimized for QSI6611/6612 PHY/MAC
- Guaranteed to operate with 8 mA DC Bias at 70°C on Cable Side
- Complies with or exceeds IEEE 802.3, 10/100Base-TX Standards

Electrical Parameters @ 25° C

OCL (@ 70°C)	Insertion Loss (dB Max.)			Return Loss (dB Min.)			Common Mode Rejection (dB Min.)			Crosstalk (dB Min.)	
	1-80 MHz	80-100 MHz	100-150 MHz	1-30 MHz	30-60 MHz	60-100 MHz	1-30 MHz	30-100 MHz	100-500 MHz	5-10 MHz	10-100 MHz
100 KHz, 0.1 Vrms 8 mA DC Bias											
Cable Side	Xmit/Rcv	Xmit/Rcv	Xmit/Rcv	Xmit/Rcv	Xmit/Rcv	Xmit/Rcv	Xmit/Rcv	Xmit/Rcv	Xmit/Rcv		
350 μ H	-1/-1	-2/-2	-3.5/-3	-18/-18	-12/-12	-10/-10	-40/-40	-30/-30	-10/-10	-35	-35

• Isolation : 1500 Vrms • Impedance : 100 Ω • Rise Time : 3.0 nS Max. •

Schematic

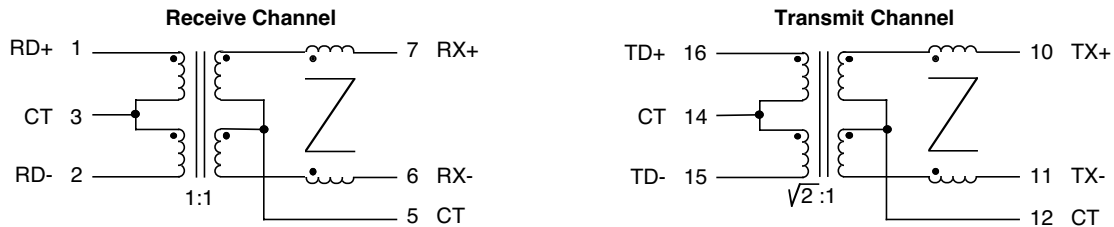

Package

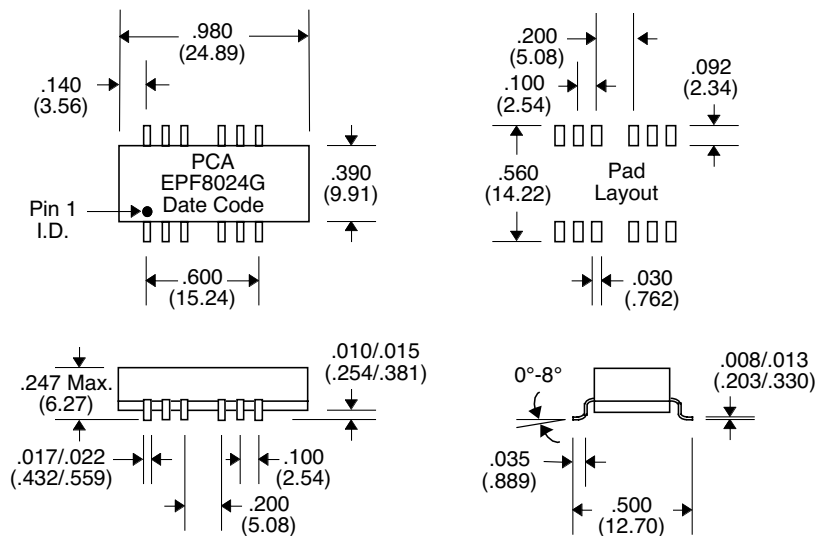

Unless Otherwise Specified Dimensions are in Inches /mm $\pm .010 / .25$