

D/A Converter Series for Electronic Adjustments

Standard 8bit 10ch/12ch Type

D/A Converters



BH2223FV, BH2221FV

No.09052EAT06

●Description

BH2223FV and BH2221FV are high performance 8bit R-2R-type D/A converters with 10 and 12 channels outputs, respectively. A built-in RESET function ensures that the output voltage at all channels is Low during power up. And a broad power supply voltage range (2.7V - 5.5V) provides design flexibility.

●Features

- 1) Built-in RESET function
- 2) High speed output response characteristics
- 3) 3-line serial interface
- 4) Broad power supply voltage range: 2.7V- 5.5V

●Applications

DVCs, DSCs, DVDs, CD-Rs, CD-RWs

●Lineup

Parameter	BH2223FV	BH2221FV
Power source voltage range	2.7 to 5.5V	2.7 to 5.5V
Number of channels	10ch	12ch
Current consumption	1.6mA	1.8mA
Differential non linearity error	±1.0LSB	±1.0LSB
Integral non linearity error	±1.5LSB	±1.5LSB
Output current performance	±1.0mA	±1.0mA
Settling time	100μs	100μs
Data transfer frequency	10MHz	10MHz
Input method	CMOS	CMOS
Data latch method	LD method	LD method
Package	SSOP-B16	SSOP-B20

●Absolute Maximum Ratings (Ta=25°C)

Parameter	Symbol	Limits	Unit	Remarks
Power source voltage	VCC	-0.3 to 7.0	V	
Terminal voltage	VIN	-0.3 to VCC	V	
Storage temperature range	TSTG	-55 to 125	°C	
Power dissipation	PD	650*1	mW	BH2221FV
		450*2	mW	BH2223FV

*1 Derated at 6.5mW/°C at Ta>25°C

*2 Derated at 4.5mW/°C at Ta>25°C

*3 These products are not robust against radiation

●Recommended Operating Conditions (Ta=25°C)

Parameter	Symbol	Limits			Unit	Remarks
		MIN.	TYP.	MAX.		
VCC power source voltage	VCC	2.7	-	5.5	V	-
VDD power source voltage	VDD	2.7	-	VCC	V	-
Terminal input voltage range	VIN	0	-	VCC	V	-
Analog output current	IO	-1.0	0	1.0	mA	-
Action temperature range	TOPR	-20	-	85	°C	-
Serial clock frequency	FSCLK	-	1.0	10.0	MHz	-
Limit load capacity	CL	-	-	0.1	μF	-

●Electrical Characteristics (Unless otherwise specified, VCC=3.0V, VDD=3.0V, RL=OPEN, CL=0pF, Ta=25°C)

Parameter	Symbol	Limits			Unit	Conditions
		MIN.	TYP.	MAX.		
<Current consumption>						
VCC system	ICC	-	0.6	1.5	mA	CLK=1MHz, 80H setting
VDD system	IDD	-	1.0	2.0	mA	
<Logic interface>						
L input voltage	VIL	GND	-	0.2VCC	V	
H input voltage	VIH	0.8VCC	-	VCC	V	
Input current	IIN	-10	-	10	μA	
<Buffer amplifier>						
Output zero scale voltage	ZS1	GND	-	0.1	V	00H setting, at no load
	ZS2	GND	-	0.3	V	00H setting, IOH=1.0mA
Output full scale voltage	FS1	VCC-0.1	-	VCC	V	FFH setting, at no load
	FS2	VCC-0.3	-	VCC	V	FFH setting, IOL=1.0mA
<D/A converter precision>						
Differential non linearity error	DNL	-1.0	-	1.0	LSB	Input code 02H to FDH
Integral non linearity error	INL	-1.5	-	1.5	LSB	Input code 02H to FDH
VCC power source voltage rise time	trVCC	100	-	-	μs	VCC=0→2.7V
Power ON reset release voltage	VPOR	-	1.9	-	V	

●Timing Chart (VCC = 3.0V, VDD = 3.0V, RL = OPEN, CL = 0pF, Ta = 25°C, unless otherwise specified.)

Parameter	Symbol	Limits			Unit	Conditions
		MIN.	TYP.	MAX.		
CLK L level time	tCLKL	50	-	-	ns	
CLK H level time	tCLKH	50	0	0	ns	
DI setup time	tsDI	20	-	-	ns	
DI hold time	thDI	40	-	-	ns	
LD setup time	tsLD	50	-	-	ns	
LD hold time	thLD	50	-	-	ns	
LD H level time	tLDH	50	-	-	ns	
Output settling time	tOUT	-	-	100	μs	CL=50pF, RL=10kΩ

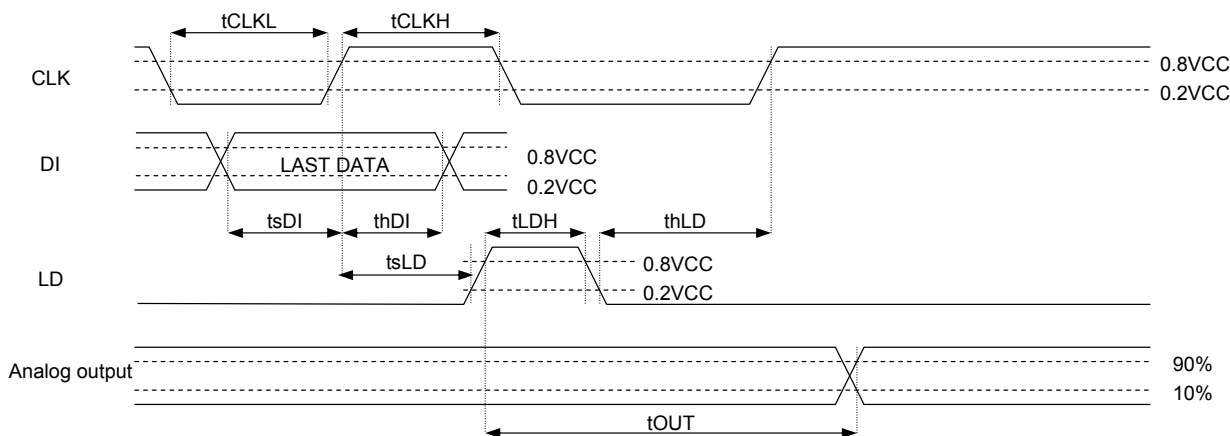

Fig.1

● Pin Description / Block Diagrams

(BH2223FV)

Terminal	Terminal name	Function
1	AO2	Analog output terminal
2	AO3	
3	AO4	
4	AO5	
5	AO6	
6	AO7	
7	AO8	
8	AO9	
9	VCC	Power source terminal
10	AO10	Analog output terminal
11	NC	Not connected yet
12	LD	Serial data load input terminal
13	CLK	Serial clock input terminal
14	DI	Serial data input terminal
15	AO1	Analog output terminal
16	GND	Ground terminal

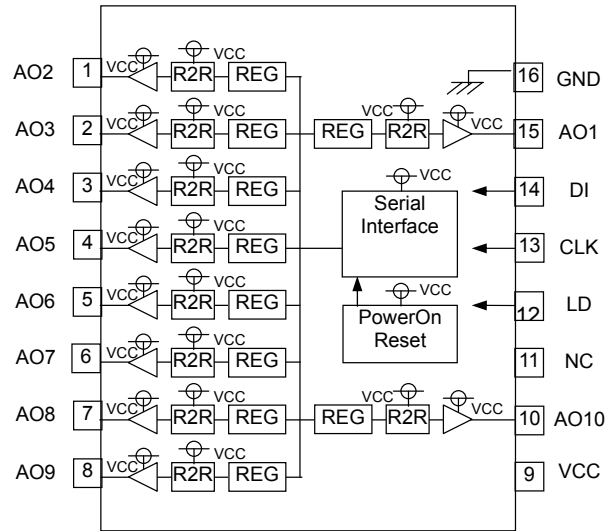

Fig.2

(BH2221FV)

Terminal	Terminal name	Function
1	NC	Not connected yet
2	AO3	Analog output terminal
3	AO4	
4	AO5	
5	AO6	
6	AO7	
7	AO8	
8	AO9	
9	AO10	
10	VDD	D/A converter standard power source terminal
11	VCC	Power source terminal
12	AO11	Analog output terminal
13	AO12	
14	NC	Not connected yet
15	LD	Serial data
16	CLK	Serial clock input terminal
17	DI	Serial data input terminal
18	AO1	Analog output terminal
19	AO2	
20	GND	Ground terminal

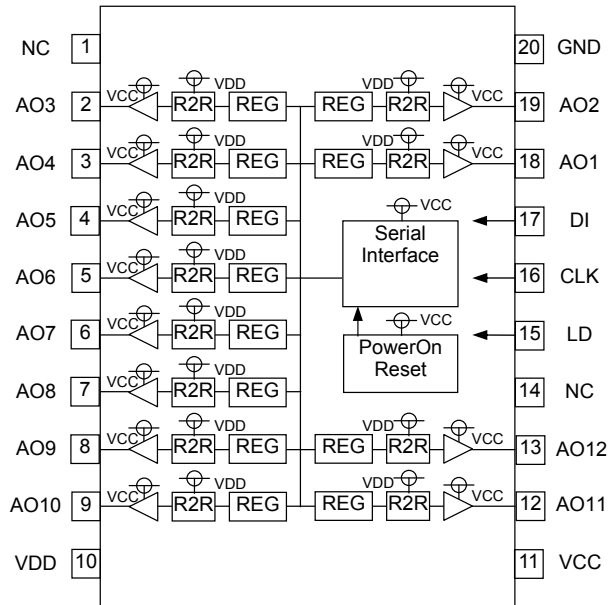

Fig.3

●Equivalent Circuit

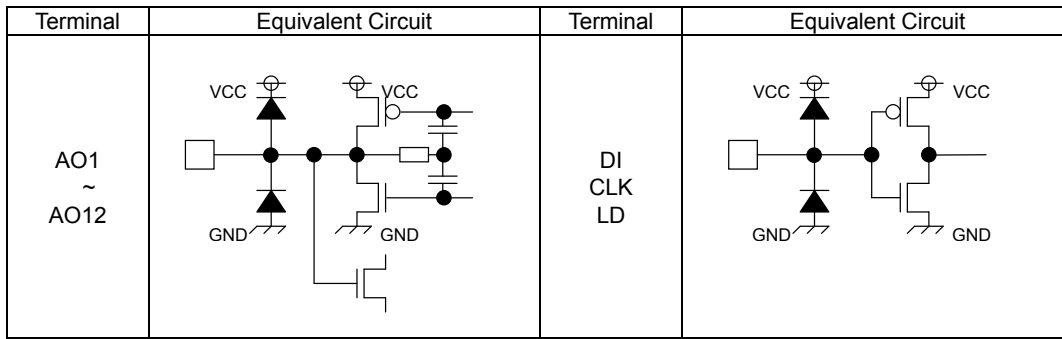

Fig.4 Equivalent Circuit

●Operation Description

Command Transmission

The Control command consists of 3 lines of 12bit serial input data (MSB first).

Data is read at the rising edge of the CLK, and output data is determined in LD High area and held in the LD Low area.

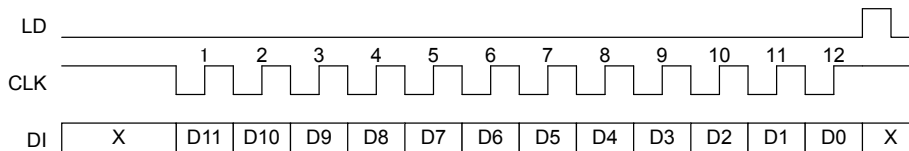

Fig.5

Data Settings

D0	D1	D3	D3	D4	D5	D6	D7	Setting
0	0	0	0	0	0	0	0	GND
1	0	0	0	0	0	0	0	(VCC or VDD-GND)/256x1
0	1	0	0	0	0	0	0	(VCC or VDD-GND)/256x2
1	1	0	0	0	0	0	0	(VCC or VDD -GND)/256x3
0	0	1	0	0	0	0	0	(VCC or VDD -GND)/256x4
~								~
0	1	1	1	1	1	1	1	(VCC or VDD -GND)/256x254
1	1	1	1	1	1	1	1	(VCC or VDD -GND)/256x255

Channel Settings

D8	D9	D10	D11	BH2223FV	BH2221FV
0	0	0	0	Inconsequential	Inconsequential
0	0	0	1	AO1	AO1
0	0	1	0	AO2	AO2
0	0	1	1	AO3	AO3
0	1	0	0	AO4	AO4
0	1	0	1	AO5	AO5
0	1	1	0	AO6	AO6
0	1	1	1	AO7	AO7
1	0	0	0	AO8	AO8
1	0	0	1	AO9	AO9
1	0	1	0	AO10	AO10
1	0	1	1	Inconsequential	AO11
1	1	0	0	Inconsequential	AO12
1	1	0	1	Inconsequential	Inconsequential
1	1	1	0	Inconsequential	Inconsequential
1	1	1	1	Inconsequential	Inconsequential

●Electrical Characteristics Curves

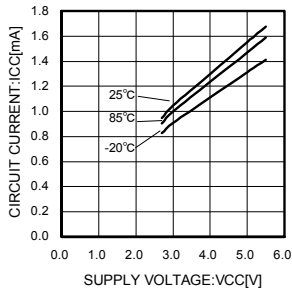

Fig.6 VCC system current consumption

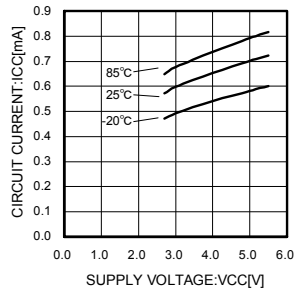

Fig.7 VDD system current consumption

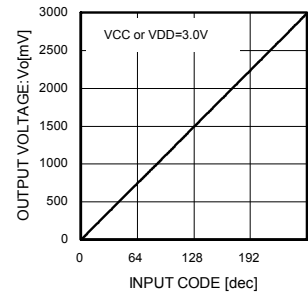

Fig.8 Output voltage characteristic

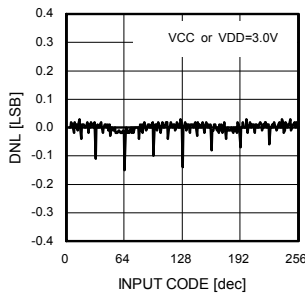

Fig.9 Differential non linearity error

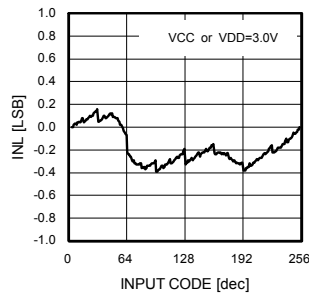

Fig.10 Integral non linearity error

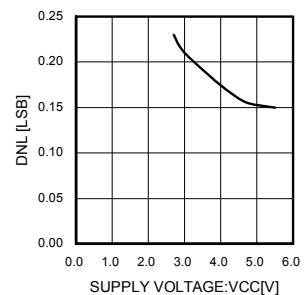

Fig.11 Power source voltage to differential non linearity error

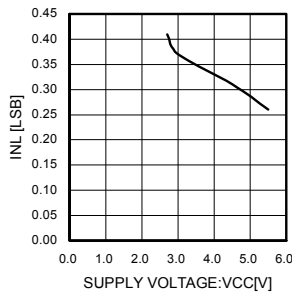

Fig.12 Power source voltage to integral non linearity error

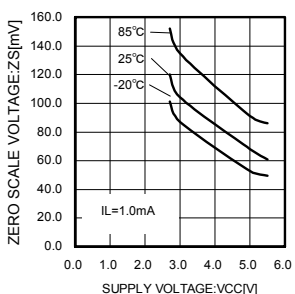

Fig.13 Output zero scale voltage

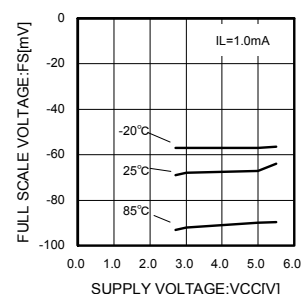

Fig.14 Output full scale voltage

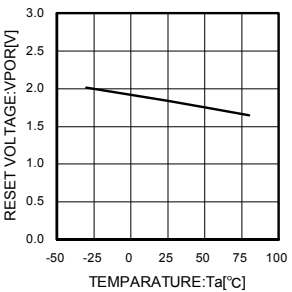

Fig.15 Reset release voltage

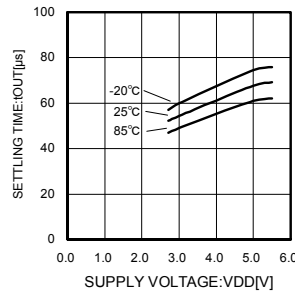

Fig.16 Settling time

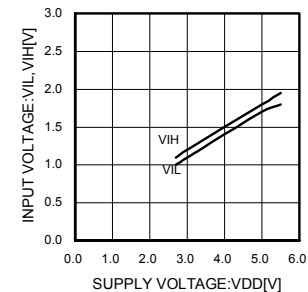

Fig.17 Input voltage

● Operation Notes

(1) Numbers and data in entries are representative design values and are not guaranteed values of the items.

(2) Although we are confident in recommending the sample application circuits, carefully check their characteristics further when using them. When modifying externally attached component constants before use, determine them so that they have sufficient margins by taking into account variations in externally attached components and the Rohm LSI, not only for static characteristics but also including transient characteristics.

(3) Absolute maximum ratings

Operating or testing the device over the maximum specifications may damage the part itself as well as peripheral components. Therefore, please ensure that the specifications are not exceeded.

(4) GND potential

Ensure that the GND terminal is at the lowest potential under all operating conditions.

(5) Thermal design

Use a thermal design that allows for a sufficient margin regarding power dissipation (Pd) under actual operating conditions.]

(6) Terminal shorts and mis-mounting

Incorrect orientation or misalignment of the IC when mounting to the PCB may damage part. Short-circuits caused by the introduction of foreign matter between the output terminals or across the output and power supply or GND may also result in destruction.

(7) Operation in a strong magnetic field

Operation in a strong electromagnetic field may cause malfunction.

(8) Power source voltage

Set the power source voltage so that $V_{CC} \geq V_{DD}$.

(9) Reset Function

The power on reset circuit, which initializes internal settings, may malfunction during abrupt power ons. Therefore, set the time constant so as to satisfy the power source rise time.

● Thermal Derating Curve

① SSOP-B20(BH2221FV)

② SSOP-B16(BH2223FV)

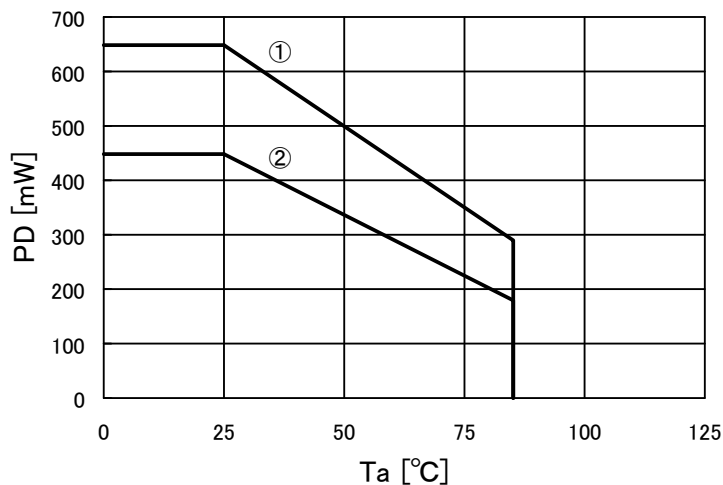

Mounted on a 70x70x1.6mm FR4 glass epoxy board (copper foil area 3% or below)

Fig.18

● Ordering part number

B	H
---	---

Part No.

2	2	2	3
---	---	---	---

Part No.
2223
2221

F	V
---	---

Package
FV: SSOP-B16
FV: SSOP-B20

E	2
---	---

Packaging and forming specification
E2: Embossed tape and reel

SSOP-B16

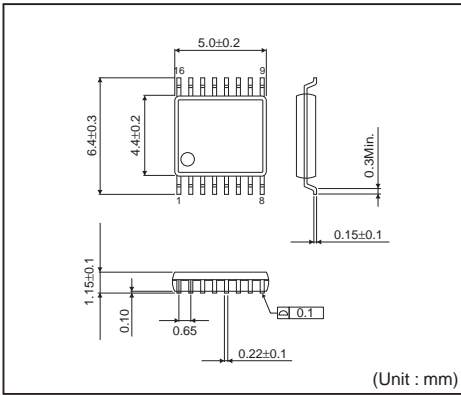

<Tape and Reel information>

Tape	Embossed carrier tape
Quantity	2500pcs
Direction of feed	E2 (The direction is the 1pin of product is at the upper left when you hold reel on the left hand and you pull out the tape on the right hand)

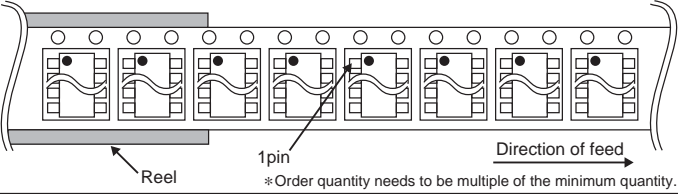

SSOP-B20

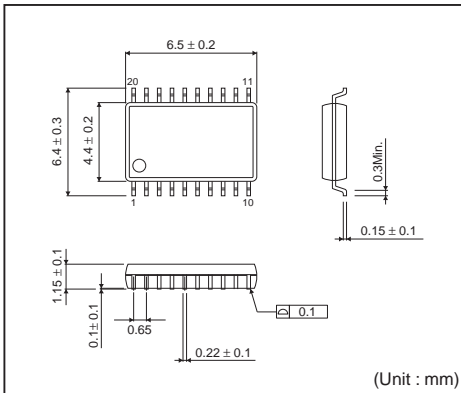

<Tape and Reel information>

Tape	Embossed carrier tape
Quantity	2500pcs
Direction of feed	E2 (The direction is the 1pin of product is at the upper left when you hold reel on the left hand and you pull out the tape on the right hand)

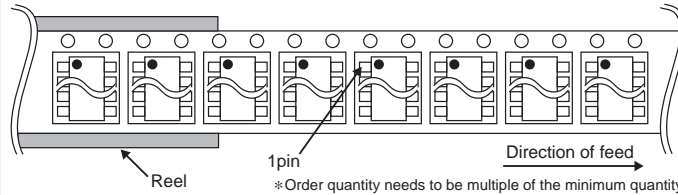

Notes

No copying or reproduction of this document, in part or in whole, is permitted without the consent of ROHM Co.,Ltd.

The content specified herein is subject to change for improvement without notice.

The content specified herein is for the purpose of introducing ROHM's products (hereinafter "Products"). If you wish to use any such Product, please be sure to refer to the specifications, which can be obtained from ROHM upon request.

Examples of application circuits, circuit constants and any other information contained herein illustrate the standard usage and operations of the Products. The peripheral conditions must be taken into account when designing circuits for mass production.

Great care was taken in ensuring the accuracy of the information specified in this document. However, should you incur any damage arising from any inaccuracy or misprint of such information, ROHM shall bear no responsibility for such damage.

The technical information specified herein is intended only to show the typical functions of and examples of application circuits for the Products. ROHM does not grant you, explicitly or implicitly, any license to use or exercise intellectual property or other rights held by ROHM and other parties. ROHM shall bear no responsibility whatsoever for any dispute arising from the use of such technical information.

The Products specified in this document are intended to be used with general-use electronic equipment or devices (such as audio visual equipment, office-automation equipment, communication devices, electronic appliances and amusement devices).

The Products specified in this document are not designed to be radiation tolerant.

While ROHM always makes efforts to enhance the quality and reliability of its Products, a Product may fail or malfunction for a variety of reasons.

Please be sure to implement in your equipment using the Products safety measures to guard against the possibility of physical injury, fire or any other damage caused in the event of the failure of any Product, such as derating, redundancy, fire control and fail-safe designs. ROHM shall bear no responsibility whatsoever for your use of any Product outside of the prescribed scope or not in accordance with the instruction manual.

The Products are not designed or manufactured to be used with any equipment, device or system which requires an extremely high level of reliability the failure or malfunction of which may result in a direct threat to human life or create a risk of human injury (such as a medical instrument, transportation equipment, aerospace machinery, nuclear-reactor controller, fuel-controller or other safety device). ROHM shall bear no responsibility in any way for use of any of the Products for the above special purposes. If a Product is intended to be used for any such special purpose, please contact a ROHM sales representative before purchasing.

If you intend to export or ship overseas any Product or technology specified herein that may be controlled under the Foreign Exchange and the Foreign Trade Law, you will be required to obtain a license or permit under the Law.



Thank you for your accessing to ROHM product informations.
More detail product informations and catalogs are available, please contact us.

ROHM Customer Support System

<http://www.rohm.com/contact/>