

## X9448

### Dual Digitally Controlled Potentiometer (XDCCP™) & Voltage Comparator

#### FEATURES

- Two digitally controlled potentiometers and two voltage comparators in one package
- 2-wire serial interface
- Register oriented format
  - Direct read/write wiper position
  - Store as many as four positions per pot
- Fast response comparator
- Enable, latch, or shutdown comparator outputs through ACR
- Auto-recall of WCR and ACR data from R0
- Hardware write protection,  $\overline{WP}$
- Separate analog and digital/system supplies
- Direct write cell
  - Endurance—100,000 data changes per bit per register
  - Register data retention—100 years
- 16-bytes of EEPROM memory
- Power saving feature and low noise
- Two 10K $\Omega$  or two 2.5K $\Omega$  potentiometers
- Resolution: 64 taps each pot
- 24-lead TSSOP and 24-lead SOIC packages

#### DESCRIPTION

The X9448 integrates two nonvolatile digitally controlled potentiometers (XDCCP) and two voltage comparators on a CMOS monolithic microcircuit.

The X9448 contains two resistor arrays, each composed of 63 resistive elements. Between each element and at either end are tap points accessible to the wiper elements. The position of the wiper element on the array is controlled by the user through the two wire serial bus interface.

Each potentiometer has an associated voltage comparator. The comparator compares the external input voltage  $V_{NI}$  with the wiper voltage  $V_W$  and sets the output voltage level to a logic high or low.

Each resistor array and comparator has associated with it a wiper counter register (WCR), analog control register (ACR), and eight 6-bit data registers that can be directly written and read by the user. The contents of the wiper counter register controls the position of the wiper on the resistor array. The contents of the analog control register controls the comparator and its output. The potentiometer is programmed with a 2-wire serial interface

#### BLOCK DIAGRAM

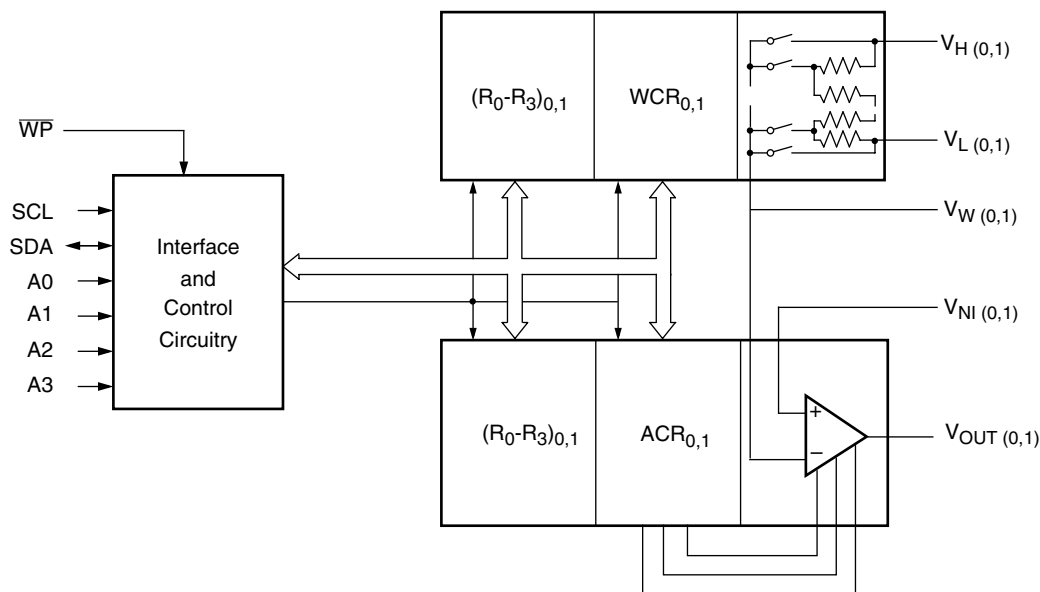

# X9448

## PIN DESCRIPTIONS

### Host Interface Pins

#### Serial Clock (SCL)

The SCL input is used to clock data into and out of the X9448.

#### Serial Data (SDA)

SDA is a bidirectional pin used to transfer data into and out of the device. It is an open drain output and may be wire-ORed with any number of open drain or open collector outputs. An open drain output requires the use of a pull-up resistor. For selecting typical values, refer to the guidelines for calculating typical values on the bus pull-up resistors graph.

#### Device Address (A<sub>0</sub>-A<sub>3</sub>)

The address inputs are used to set the least significant 4 bits of the 8-bit slave address. A match in the slave address serial data stream must be made with the address input in order to initiate communication with the X9448. A maximum of 16 devices may share the same 2-wire serial bus.

### Potentiometer Pins

#### V<sub>H</sub> (V<sub>H0</sub>-V<sub>H1</sub>), V<sub>L</sub> (V<sub>L0</sub>-V<sub>L1</sub>)

The V<sub>H</sub> and V<sub>L</sub> inputs are equivalent to the terminal connections on either end of a mechanical potentiometer.

#### V<sub>W</sub> (V<sub>W0</sub>-V<sub>W1</sub>)

The wiper output is equivalent to the wiper output of a mechanical potentiometer and is connected to the inverting input of the voltage comparator.

### Comparator and Device Pins

#### Voltage Input V<sub>NI0</sub>, V<sub>NI1</sub>

V<sub>NI0</sub> and V<sub>NI1</sub> are the input voltages to the plus (non-inverting) inputs of the two comparators.

#### Buffered Voltage Outputs V<sub>OUT0</sub>, V<sub>OUT1</sub>

The V<sub>OUT0</sub>, and V<sub>OUT1</sub> are the buffered voltage comparator outputs enabled by respective bits in the volatile analog control register.

#### Hardware Write Protect Input $\overline{WP}$

The  $\overline{WP}$  pin when low prevents nonvolatile writes to the wiper counter and analog control registers.

#### Analog Supplies V<sub>+</sub>, V<sub>-</sub>

The analog supplies V<sub>+</sub>, V<sub>-</sub> are the supply voltages for the XDCP analog section and the voltage comparators.

#### System Supply V<sub>CC</sub> and Ground V<sub>SS</sub>

The system supply V<sub>CC</sub> and its reference V<sub>SS</sub> is used to bias the interface and control circuits.

## PIN CONFIGURATION

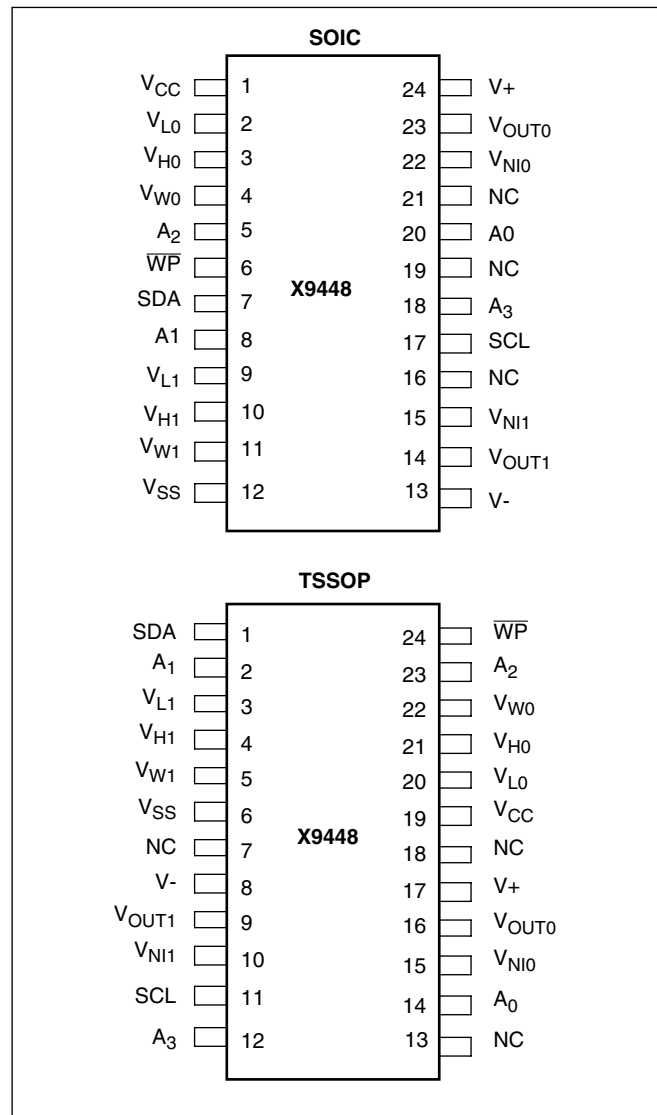

# X9448

## PIN NAMES

Symbol	Description
SCL	Serial Clock
SDA	Serial Data
A0-A3	Device Address
$V_{H0}-V_{H1}$ , $V_{L0}-V_{L1}$	Potentiometers (terminal equivalent)
$V_{W0}-V_{W1}$	Potentiometers (wiper equivalent)
$V_{NI0}$ , $V_{NI1}$	Comparator Input Voltages
$V_{OUT0}$ , $V_{OUT1}$	Buffered Comparator Outputs
WP	Hardware Write Protection
$V_{+}$ , $V_{-}$	Analog and Voltage Comparator Supplies
$V_{CC}$	System/Digital Supply Voltage
$V_{SS}$	System Ground
NC	No Connection

## PRINCIPLES OF OPERATION

The X9448 is a highly integrated microcircuit incorporating two resistor arrays, two voltage comparators and their associated registers and counters; and the serial interface logic providing direct communication between the host and the digitally-controlled potentiometers and voltage comparators.

### Serial Interface

The X9448 supports a bidirectional bus oriented protocol. The protocol defines any device that sends data onto the bus as a transmitter and the receiving device as the receiver. The device controlling the transfer is a master and the device being controlled is the slave. The master will always initiate data transfers and provide the clock for both transmit and receive operations. Therefore, the X9448 will be considered a slave device in all applications.

### Clock and Data Conventions

Data states on the SDA line can change only during SCL LOW periods ( $t_{LOW}$ ). SDA state changes during SCL HIGH are reserved for indicating start and stop conditions.

### Start Condition

All commands to the X9448 are preceded by the start condition, which is a HIGH to LOW transition of SDA while SCL is HIGH ( $t_{HIGH}$ ). The X9448 continuously monitors the SDA and SCL lines for the start condition and will not respond to any command until this condition is met.

### Stop Condition

All communications must be terminated by a stop condition, which is a LOW to HIGH transition of SDA while SCL is HIGH.

### Acknowledge

Acknowledge is a software convention used to provide a positive handshake between the master and slave devices on the bus to indicate the successful receipt of data. The transmitting device, either the master or the slave, will release the SDA bus after transmitting eight bits. The master generates a ninth clock cycle and during this period the receiver pulls the SDA line LOW to acknowledge that it successfully received the eight bits of data.

The X9448 will respond with an acknowledge after recognition of a start condition and its slave address and once again after successful receipt of the command byte. If the command is followed by a data byte the X9448 will respond with a final acknowledge.

### Array Description

The X9448 is comprised of two resistor arrays and two voltage comparators. Each array contains 63 discrete resistive segments that are connected in series. The physical ends of each array are equivalent to the fixed terminals of a mechanical potentiometer ( $V_H$  and  $V_L$  inputs).

At both ends of each array and between each resistor segment is a CMOS switch connected to the wiper ( $V_W$ ) output. Within each individual array only one switch may be turned on at a time. These switches are controlled by a volatile wiper counter register (WCR). The six bits of the WCR are decoded to select, and enable, one of sixty-four switches.

The WCR may be written directly, or it can be changed by transferring the contents of one of four associated data registers into the WCR. These data registers and the WCR can be read and written by the host system.

# X9448

## Voltage Comparator

The comparator compares the wiper voltage  $V_W$  with the external input voltage  $V_{NI}$ . The comparator and its logic level output are controlled by the Shutdown, Latch, and Enable bits of the analog control register (ACR). Enable connects the comparator output to the  $V_{OUT}$  pin, Latch memorizes the output logic state, and Shutdown removes the analog section supply voltages to save power. The analog control register is programmed using the two wire serial interface.

The ACR may be written directly, or it can be changed by transferring the contents of one of four associated data registers into the ACR. These data registers and the ACR may be read and written by the host system.

## INSTRUCTIONS AND PROGRAMMING

### Device Addressing

Following a start condition the master must output the address of the slave it is accessing. The most significant four bits of the slave address are the device type identifier (refer to Figure 1 below). For the X9448 this is fixed as 0101[B].

Figure 1. Address/Identification Byte Format

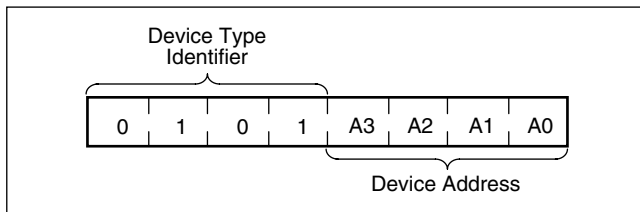

The next four bits of the slave address are the device address. The physical device address is defined by the state of the A0-A3 inputs. The X9448 compares the serial data stream with the address input state; a successful compare of all four address bits is required for the X9448 to respond with an acknowledge. The A0–A3 inputs can be actively driven by CMOS input signals or tied to  $V_{CC}$  or  $V_{SS}$ .

### Acknowledge Polling

The disabling of the inputs, during the internal nonvolatile write operation, can be used to take advantage of the typical 5ms EEPROM write cycle time. Once the stop condition is issued to indicate the end of the nonvolatile write command the X9448 initiates the internal

write cycle. ACK polling (Flow 1) can be initiated immediately. This involves issuing the start condition followed by the device slave address. If the X9448 is still busy with the write operation no ACK will be returned. If the X9448 has completed the write operation an ACK will be returned and the master can then proceed with the next operation.

Flow 1. ACK Polling Sequence

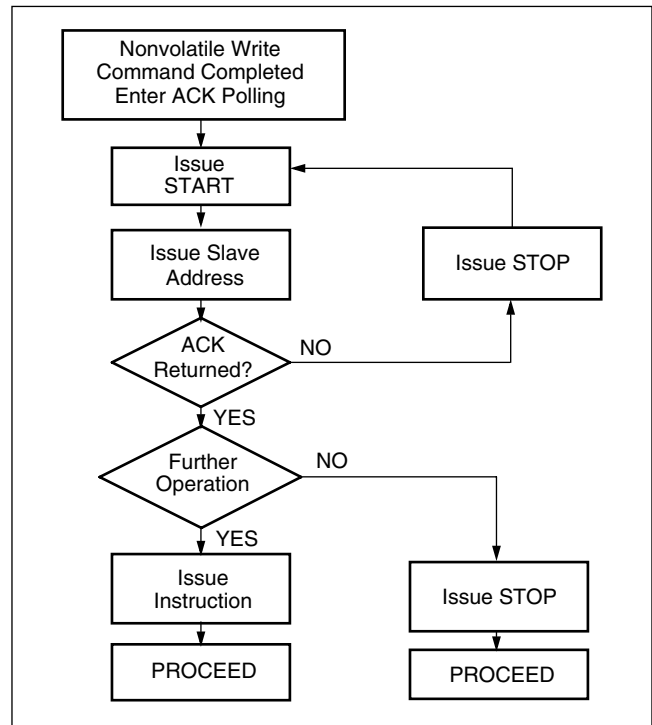

### Instruction Structure

The byte following the address contains the instruction and register pointer information. The four most significant bits are the instruction. The next four bits point to one of two pots or one of two voltage comparators and when applicable they point to one of four associated registers. The format is shown below in Figure 2.

Figure 2. Instruction Byte Format

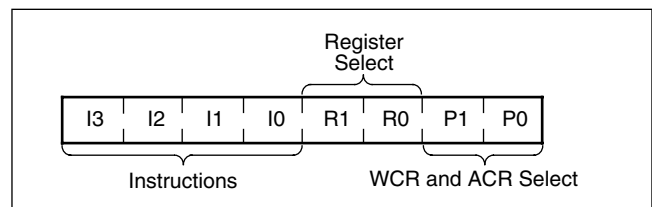

The four high order bits define the instruction. The next two bits (R1 and R0) select one of the four registers that is to be acted upon when a register oriented instruction is issued. The last two bits (P1 and P0) select which one of the two potentiometers or which one of the two voltage comparators is to be affected by the instruction.

Four of the nine instructions end with the transmission of the instruction byte. The basic sequence is illustrated in Figure 3. These two-byte instructions exchange data between the wiper counter register or analog control register and one of the data registers. A transfer from a data register to a wiper counter register or analog control register is essentially a write to a static RAM. The response of the wiper to this action will be delayed  $t_{STPWV}$ . A transfer from the Wiper Counter Register current wiper position to a data register is a write to nonvolatile memory and takes a minimum of  $t_{WR}$  to complete. The transfer can occur between one of the two potentiometers or one of the two voltage comparators and one of its associated registers; or it may occur globally, wherein the transfer occurs between both of the potentiometers and voltage comparators and one of their associated registers.

Four instructions require a three-byte sequence to complete. The basic sequence is illustrated in Figure 4. These instructions transfer data between the host and the X9448; either between the host and one of the data registers or directly between the host and the wiper counter and analog control registers. These instructions are: read wiper counter register or analog control register, read the current wiper position of the selected pot or the comparator control bits, Write wiper counter register or analog control register, i.e. change current wiper position of the selected pot or control the voltage comparator; read data register, read the contents of the selected nonvolatile register; write data register, write a new value to the selected data register. The bit structures of the instructions are shown in Figure 6.

The increment/decrement command is different from the other commands. Once the command is issued and the X9448 has responded with an acknowledge, the master can clock the selected wiper up and/or down in one segment steps; thereby, providing a fine tuning capability to the host. For each SCL clock pulse ( $t_{HIGH}$ ) while SDA is HIGH, the selected wiper will move one resistor segment towards the  $V_H$  terminal. Similarly, for each SCL clock pulse while SDA is LOW, the selected wiper will move one resistor segment towards the  $V_L$  terminal. A detailed illustration of the sequence for this operation is shown in Figure 5.

**Figure 3. Two-Byte Command Sequence**

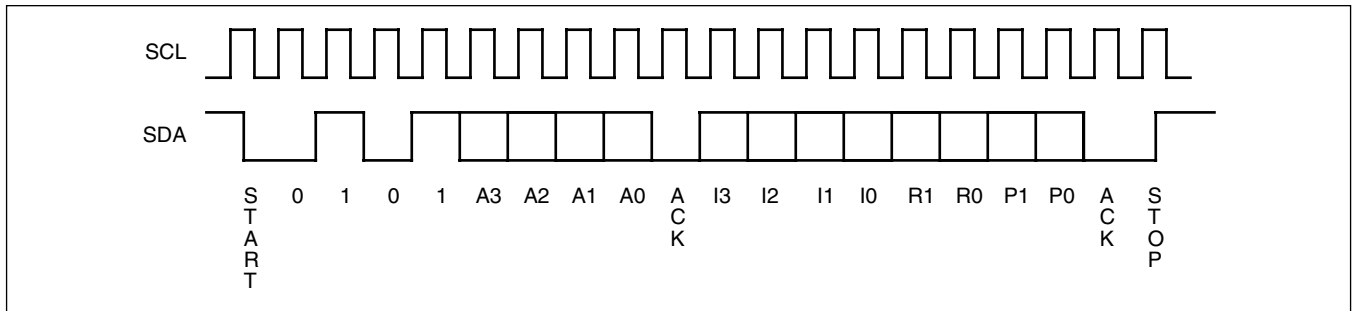

**Figure 4. Three-Byte Command Sequence**

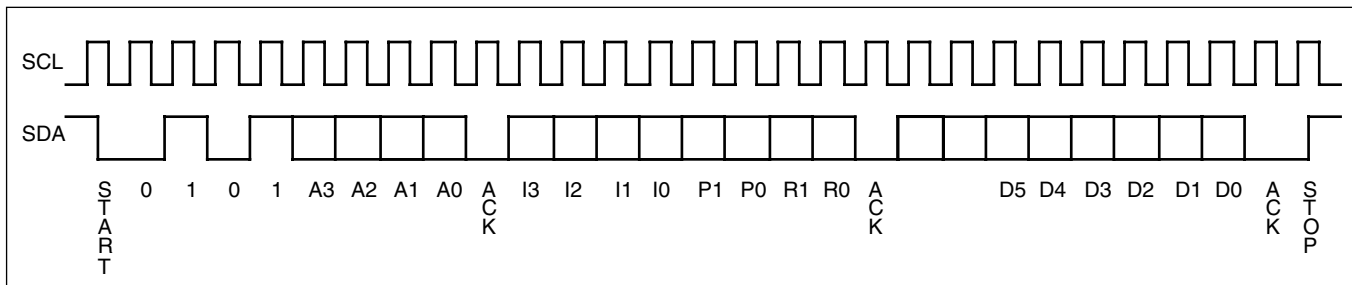
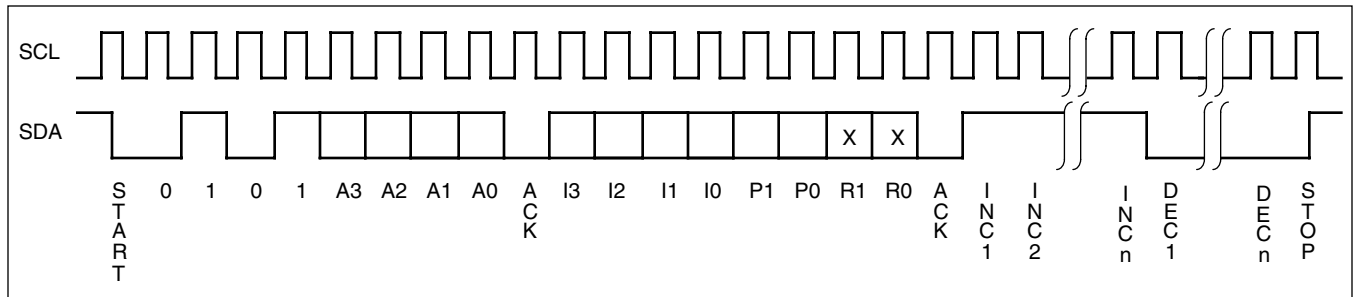

Figure 5. Increment/Decrement Command Sequence



**INSTRUCTION SET**

**Read Wiper Counter Register (WCR) or Analog Control Register (ACR)**

Read the contents of the Wiper Counter Register or Analog Control Register pointed to by P<sub>1</sub>-P<sub>0</sub>.

S T A R T	device type identifier				device addresses				S A C K	instruction opcode				WCR/ACR addresses				S A C K	register data (sent by slave on SDA)								M A C K	S T O P
	0	1	0	1	A	A	A	A		1	0	0	1	0	0	P	P		0	0	D	D	D	D	D	D		
	0	1	0	1	A	A	A	A	1	0	0	1	0	0	P	P	0	0	D	D	D	D	D	D	D	D		

P1 P0: 00-WCR0, 01 - WCR1  
P1 P0: 10-ACR0, 11 - ACR1

**Write Wiper Counter Register (WCR) or Analog Control Register (ACR)**

Write new value to the Wiper Counter Register or Analog Control Register pointed to by P<sub>1</sub>-P<sub>0</sub>.

S T A R T	device type identifier				device addresses				S A C K	instruction opcode				WCR/ACR addresses				S A C K	register data (sent by master on SDA)								S A C K	S T O P
	0	1	0	1	A	A	A	A		1	0	1	0	0	0	P	P		0	0	D	D	D	D	D	D		
	0	1	0	1	A	A	A	A	1	0	1	0	0	0	P	P	0	0	D	D	D	D	D	D	D	D		

P1 P0: 00-WCR0, 01 - WCR1  
P1 P0: 10-ACR0, 11 - ACR1

**Read Data Register (DR)**

Read the contents of the Register pointed to by P<sub>1</sub>-P<sub>0</sub> and R<sub>1</sub>-R<sub>0</sub>.

S T A R T	device type identifier				device addresses				S A C K	instruction opcode				WCR/ACR/DR addresses				S A C K	register data (sent by master on SDA)								M A C K	S T O P
	0	1	0	1	A	A	A	A		1	0	1	1	R	R	P	P		0	0	D	D	D	D	D	D		
	0	1	0	1	A	A	A	A	1	0	1	1	R	R	P	P	0	0	D	D	D	D	D	D	D	D		

R1 R0: 00-R0, 10-R1  
01-R2, 11-R3

**Definitions:**

SACK – Slave acknowledge, MACK – Master acknowledge, I/O – Increment/Decrement (I/O), R – Register, P – Potentiometer

# X9448

## Write Data Register (DR)

Write new value to the Register pointed to by P<sub>1</sub>-P<sub>0</sub> and R<sub>1</sub>-R<sub>0</sub>.

S T A R T	device type identifier				device addresses				S A C K	instruction opcode				WCR/ACR/DR addresses				S A C K	register data (sent by master on SDA)								S A C K	S T O P	HIGH-VOLTAGE WRITE CYCLE
	0	1	0	1	A <sub>3</sub>	A <sub>2</sub>	A <sub>1</sub>	A <sub>0</sub>		1	1	0	0	R <sub>1</sub>	R <sub>0</sub>	P <sub>1</sub>	P <sub>0</sub>		0	0	D <sub>5</sub>	D <sub>4</sub>	D <sub>3</sub>	D <sub>2</sub>	D <sub>1</sub>	D <sub>0</sub>			
	0	1	0	1	A <sub>3</sub>	A <sub>2</sub>	A <sub>1</sub>	A <sub>0</sub>		1	1	0	0	R <sub>1</sub>	R <sub>0</sub>	P <sub>1</sub>	P <sub>0</sub>		0	0	D <sub>5</sub>	D <sub>4</sub>	D <sub>3</sub>	D <sub>2</sub>	D <sub>1</sub>	D <sub>0</sub>			

## Transfer Data Register to Wiper Counter Register or Analog Control Register

Transfer the contents of the Register pointed to by R<sub>1</sub>-R<sub>0</sub> to the WCR or ACR pointed to by P<sub>1</sub>-P<sub>0</sub>.

S T A R T	device type identifier				device addresses				S A C K	instruction opcode				WCR/ACR/DR addresses				S A C K	S T O P
	0	1	0	1	A <sub>3</sub>	A <sub>2</sub>	A <sub>1</sub>	A <sub>0</sub>		1	1	0	1	R <sub>1</sub>	R <sub>0</sub>	P <sub>1</sub>	P <sub>0</sub>		
	0	1	0	1	A <sub>3</sub>	A <sub>2</sub>	A <sub>1</sub>	A <sub>0</sub>		1	1	0	1	R <sub>1</sub>	R <sub>0</sub>	P <sub>1</sub>	P <sub>0</sub>		

## Transfer Wiper Counter or Analog Control Register to Data Register

Transfer the contents of the WCR or ACR pointed to by P<sub>1</sub>-P<sub>0</sub> to the Register pointed to by R<sub>1</sub>-R<sub>0</sub>.

S T A R T	device type identifier				device addresses				S A C K	instruction opcode				WCR/ACR/DR addresses				S A C K	S T O P	HIGH-VOLTAGE WRITE CYCLE
	0	1	0	1	A <sub>3</sub>	A <sub>2</sub>	A <sub>1</sub>	A <sub>0</sub>		1	1	1	0	R <sub>1</sub>	R <sub>0</sub>	P <sub>1</sub>	P <sub>0</sub>			
	0	1	0	1	A <sub>3</sub>	A <sub>2</sub>	A <sub>1</sub>	A <sub>0</sub>		1	1	1	0	R <sub>1</sub>	R <sub>0</sub>	P <sub>1</sub>	P <sub>0</sub>			

## Global Transfer Data Register to Wiper Counter or Analog Control Register

Transfer the contents of all four Data Registers pointed to by R<sub>1</sub>-R<sub>0</sub> to their respective WCR or ACR.

S T A R T	device type identifier				device addresses				S A C K	instruction opcode				DR addresses				S A C K	S T O P
	0	1	0	1	A <sub>3</sub>	A <sub>2</sub>	A <sub>1</sub>	A <sub>0</sub>		0	0	0	1	R <sub>1</sub>	R <sub>0</sub>	0	0		
	0	1	0	1	A <sub>3</sub>	A <sub>2</sub>	A <sub>1</sub>	A <sub>0</sub>		0	0	0	1	R <sub>1</sub>	R <sub>0</sub>	0	0		

## Global Transfer Wiper Counter or Analog Control Register to Data Register

Transfer the contents of all WCRs and ACRs to their respective data Registers pointed to by R<sub>1</sub>-R<sub>0</sub>.

S T A R T	device type identifier				device addresses				S A C K	instruction opcode				DR addresses				S A C K	S T O P	HIGH-VOLTAGE WRITE CYCLE
	0	1	0	1	A <sub>3</sub>	A <sub>2</sub>	A <sub>1</sub>	A <sub>0</sub>		1	0	0	0	R <sub>1</sub>	R <sub>0</sub>	0	0			
	0	1	0	1	A <sub>3</sub>	A <sub>2</sub>	A <sub>1</sub>	A <sub>0</sub>		1	0	0	0	R <sub>1</sub>	R <sub>0</sub>	0	0			

## Increment/Decrement Wiper Counter Register

Enable Increment/decrement of the WCR pointed to by P<sub>1</sub>-P<sub>0</sub>.

S T A R T	device type identifier				device addresses				S A C K	instruction opcode				WCR addresses				S A C K	increment/decrement (sent by master on SDA)						S T O P
	0	1	0	1	A3	A2	A1	A0		0	0	1	0	0	0	P1	P0		I/D	I/D	.	.	.	.	

P1 P0: 00 or 01 only.

### REGISTERS OPERATION

Both XDCP potentiometers and voltage comparators share the serial interface and share a common architecture. Each potentiometer and voltage comparator is associated with wiper counter and analog control registers and eight data registers. A detailed discussion of the register organization and array operation follows.

#### Wiper Counter (WCR) and Analog Control Registers (ACR)

The X9448 contains two wiper counter registers one for each XDCP potentiometer and two analog control registers, one for each of the two voltage comparators. The wiper counter register is equivalent to a serial-in, parallel-out counter with its outputs decoded to select one of sixty-four switches along its resistor array. The contents of the wiper counter register and analog control register can be altered in four ways: it may be written directly by the host via the Write WCR instruction (serial load); it may be written indirectly by transferring the contents of one of four associated data registers (DR) via the XFR data register instruction (parallel load); it can be modified one step at a time by the increment/decrement instruction (WCR only). Finally, it is loaded with the contents of its data register zero (R0) upon power-up.

The wiper counter and analog control register are volatile registers; that is, their contents are lost when the X9448 is powered-down. Although the registers are automatically loaded with the value in R0 upon power-up, it should be noted this may be different from the value present at power-down.

Programming the ACR is similar to the WCR. However, the 6 bits in the WCR positions the wiper in the resistor array while 3 bits in the ACR control the comparator and its output.

### Data Registers (DR)

Each potentiometer and each voltage comparator has four nonvolatile data registers (DR). These can be read or written directly by the host and data can be transferred between any of the four data registers and the WCR or ACR. It should be noted all operations changing data in one of these registers is a nonvolatile operation and will take a maximum of 10ms.

If the application does not require storage of multiple settings for the potentiometer or comparator, these registers can be used as regular memory locations that could store system parameters or user preference data.

### REGISTER DESCRIPTIONS

#### Wiper Counter Register (WCR)

0	0	WP5	WP4	WP3	WP2	WP1	WP0
		(volatile)					(LSB)

WP0-WP5 identify wiper position.

#### Analog Control Register (ACR)

0	0	User -bit5	User -bit4	User -bit3	Latch	Enable	Shut-down
		(volatile)					(LSB)

#### Shutdown

- “1” indicates power is connected to the voltage comparator.
- “0” indicates power is not connected to the voltage comparator.

#### Enable

- “1” indicates the output buffer of the voltage comparator is enabled.
- “0” indicates the output buffer of the voltage comparator is disabled.



# X9448

---

## Latch

“1” indicates the output of the voltage comparator is memorized or latched.

“0” indicates the output of the voltage comparator is not latched.

**Userbits**—available for user applications

## Data Registers (DR, R0-R3)

Wiper Position or Analog Control Data or User Data
(Nonvolatile)

## Memory Map

WCRO	WCR1	ACR0	ACR1
R0	R0	R0	R0
R1	R1	R1	R1
R2	R2	R2	R2
R3	R3	R3	R3

# X9448

## ABSOLUTE MAXIMUM RATINGS

Temperature under bias ..... -65°C to +135°C  
 Storage temperature ..... -65°C to +150°C  
 Voltage on SDA, SCL or any address input with respect to  $V_{SS}$  ..... -1V to +7V  
 Voltage on any  $V+$  (referenced to  $V_{SS}$ ) ..... +7V  
 Voltage on any  $V-$  (referenced to  $V_{SS}$ ) ..... -7V  
 ( $V+$ ) - ( $V-$ ) ..... 10V  
 Any  $V_H$  .....  $V+$   
 Any  $V_L$  .....  $V-$   
 Lead temperature (soldering, 10 seconds) ..... 300°C

## COMMENT

Stresses above those listed under “Absolute Maximum Ratings” may cause permanent damage to the device. This is a stress rating only; functional operation of the device (at these or any other conditions above those listed in the operational sections of this specification) is not implied. Exposure to absolute maximum rating conditions for extended periods may affect device reliability.

## RECOMMENDED OPERATING CONDITIONS

Temperature	Min.	Max.
Commercial	0°C	+70°C
Industrial	-40°C	+85°C
Military	-55°C	+125°C

Device	Supply Voltage ( $V_{CC}$ ) Limits
X9448	5V ±10%
X9448-2.7	2.7V to 5.5V

## POTENTIOMETER CHARACTERISTICS (Over recommended operating conditions unless otherwise stated.)

Symbol	Parameter	Limits				Test Conditions
		Min.	Typ.	Max.	Unit	
$R_{TOTAL}$	End to end resistance	-20		+20	%	25°C, each pot
	Power rating			50	mW	
$I_W$	Wiper current	-3		+3	mA	
$R_W$	Wiper resistance		40	100	$\Omega$	$V_{CC} = 5V$ , Wiper Current = 3mA
			100	250	$\Omega$	$V_{CC} = 2.7-5V$ , Wiper Current = 3mA
$V_{v+}$	Voltage on $V+$ Pin	X9440	+4.5	+5.5	V	
		X9440-2.7	+2.7	+5.5		
$V_{v-}$	Voltage on $V-$ Pin	X9440	-5.5	-4.5	V	
		X9440-2.7	-5.5	-2.7		
$V_{TERM}$	Voltage on any $V_H$ or $V_L$ pin	$V-$		$V+$	V	
	Noise		-120		dBv	Ref: 1V
	Resolution <sup>(4)</sup>		1.6		%	
	Absolute linearity <sup>(1)</sup>	-1		+1	MI <sup>(3)</sup>	$V_{w(n)(actual)} - V_{w(n)(expected)}$
	Relative linearity <sup>(2)</sup>	-0.2		+0.2	MI <sup>(3)</sup>	$V_{w(n+1)} - [V_{w(n)} + MI]$
	Temperature Coefficient of $R_{TOTAL}$		$\pm 300$			ppm/°C

- Notes:** (1) Absolute linearity is utilized to determine actual wiper voltage versus expected voltage as determined by wiper position when used as a potentiometer.  
 (2) Relative linearity is utilized to determine the actual change in voltage between two successive tap positions when used as a potentiometer. It is a measure of the error in step size.  
 (3)  $MI = RTOT/63$  or  $(V_H - V_L)/63$ , single pot  
 (4) Individual array resolutions

## COMPARATOR ELECTRICAL CHARACTERISTICS

(Over the recommended operating conditions unless otherwise specified.)

Symbol	Parameter	Limits			Unit	Test Conditions
		Min.	Typ.	Max.		
V <sub>OS</sub>	Input offset voltage	-1		1	mV	V <sub>+</sub> /V <sub>-</sub> = ±3V
		-5		5	mV	V <sub>+</sub> /V <sub>-</sub> = ±5V
I <sub>B</sub>	Input current		10		pA	
V <sub>IR</sub>	Input voltage range	V <sub>-</sub>		V <sub>+</sub>	V	
t <sub>R</sub>	Response time		200		ns	note 1
I <sub>O</sub>	Output current	-1		1	mA	
A <sub>V</sub>	Voltage gain				V/mV	
PSRR	Power supply rejection ratio		60		dB	
V <sub>OR</sub>	Output voltage range	V <sub>SS</sub>		V <sub>CC</sub>	V	
T <sub>C</sub> V <sub>OS</sub>	Input offset voltage drift		6		µV/°C	
I <sub>S</sub>	Supply current (V <sub>+</sub> to V <sub>-</sub> )		1.2		mA	V <sub>+</sub> /V <sub>-</sub> = ±5V
			.5		mA	V <sub>+</sub> /V <sub>-</sub> = ±3V
T <sub>ON</sub>	Comparator enable time		1		µs	note 2
V <sub>OL</sub>	Output low voltage			0.4	V	I <sub>O</sub> = 1mA
V <sub>OH</sub>	Output high voltage	V <sub>CC</sub> - 0.8			V	I <sub>O</sub> = 1mA

Notes: (1) 100mV step with 100mV overdrive, Z<sub>L</sub> = 10KΩ || 15pF, 10-90% risetime

(2) Time from leading edge of enable bit to valid V<sub>OUT</sub>.

## SYSTEM/DIGITAL D.C. OPERATING CHARACTERISTICS

(Over the recommended operating conditions unless otherwise specified.)

Symbol	Parameter	Limits				Test Conditions
		Min.	Typ.	Max.	Unit	
I <sub>CC</sub>	V <sub>CC</sub> supply current (active)			400	µA	f <sub>SCL</sub> = 400kHz, SDA = Open, Other Inputs = V <sub>SS</sub>
I <sub>SB</sub>	V <sub>CC</sub> current (standby)			1	µA	SCL = SDA = V <sub>CC</sub> , Addr. = V <sub>SS</sub>
I <sub>LI</sub>	Input leakage current			10	µA	V <sub>IN</sub> = V <sub>SS</sub> to V <sub>CC</sub>
I <sub>LO</sub>	Output leakage current			10	µA	V <sub>OUT</sub> = V <sub>SS</sub> to V <sub>CC</sub>
V <sub>IH</sub>	Input HIGH voltage	V <sub>CC</sub> × 0.7		V <sub>CC</sub> + 0.5	V	
V <sub>IL</sub>	Input LOW voltage	-0.5		V <sub>CC</sub> × 0.1	V	
V <sub>OL</sub>	Output LOW voltage			0.4	V	I <sub>OL</sub> = 3mA

## ENDURANCE AND DATA RETENTION

Parameter	Min.	Unit
Minimum endurance	100,000	Data changes per bit per register
Data retention	100	Years

# X9448

## CAPACITANCE

Symbol	Test	Typical	Unit	Test Conditions
$C_{I/O}$	Input/output capacitance (SDA)	8	pF	$V_{I/O} = 0V$
$C_{IN}$	Input capacitance (A0, A1, A2, A3, and SCL)	6	pF	$V_{IN} = 0V$
$C_L, C_H, C_W$	Potentiometer capacitance	10/10/25	pF	

## Power-Up Timing and Sequence

Power up sequence <sup>(1)</sup> : (1) $V_{CC}$ (2) $V+$ and $V-$ { $V+ \leq V_{CC}$ at all times}
Power down sequence: no limitation

## A.C. TEST CONDITIONS

Input pulse levels	$V_{CC} \times 0.1$ to $V_{CC} \times 0.9$
Input rise and fall times	10ns
Input and output timing level	$V_{CC} \times 0.5$

**Note:** (1) Applicable to recall and power consumption applications

## EQUIVALENT A.C. LOAD CIRCUIT

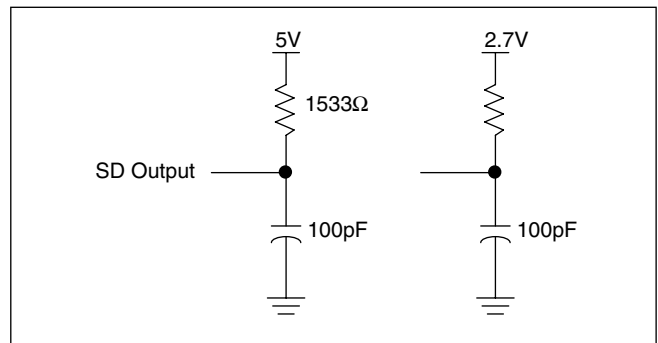

## TIMING DIAGRAMS

### START and STOP Timing

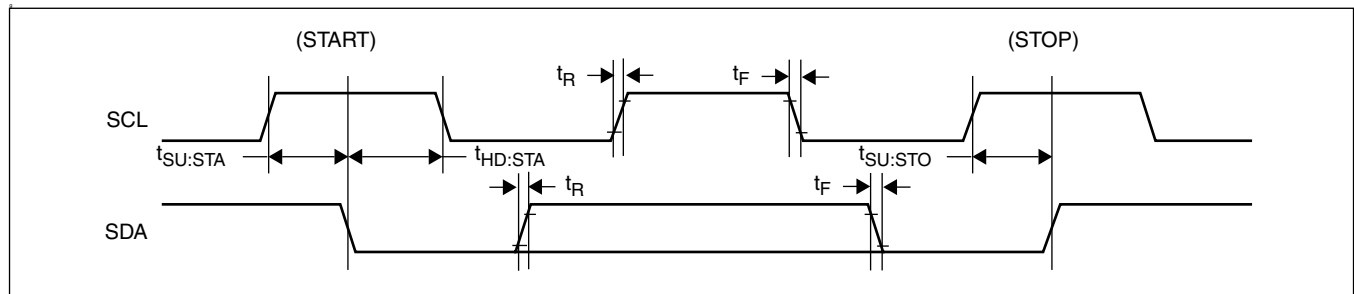

### Input Timing

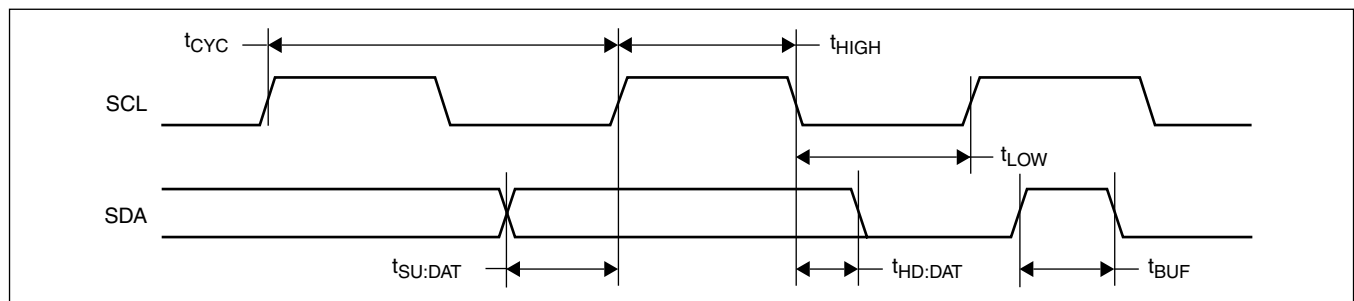

# X9448

## Output Timing

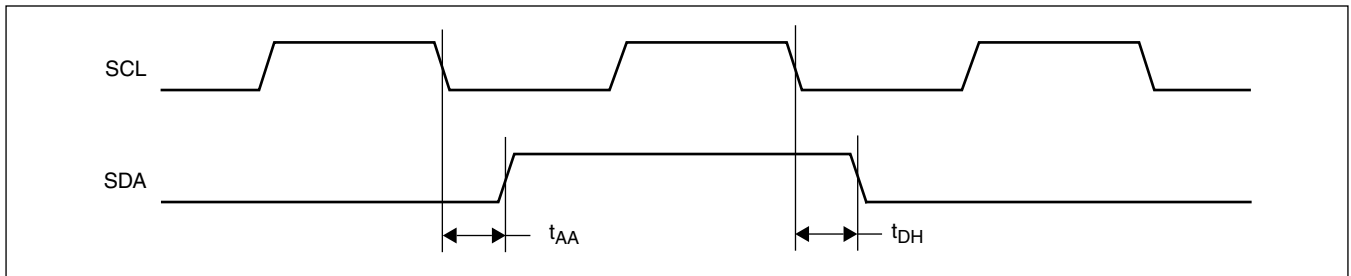

## XDCP Timing (for All Load Instructions)

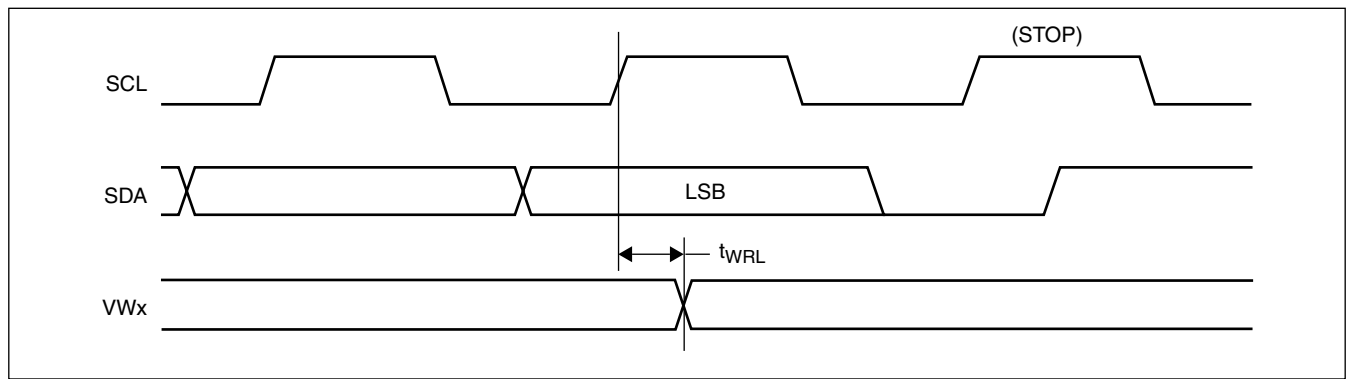

## XDCP Timing (for Increment/Decrement Instruction)

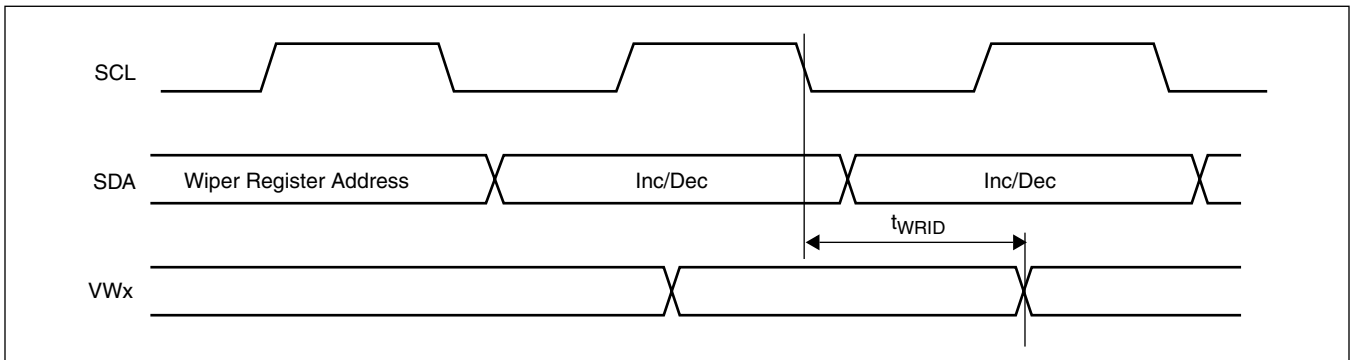

## Write Protect and Device Address Pins Timing

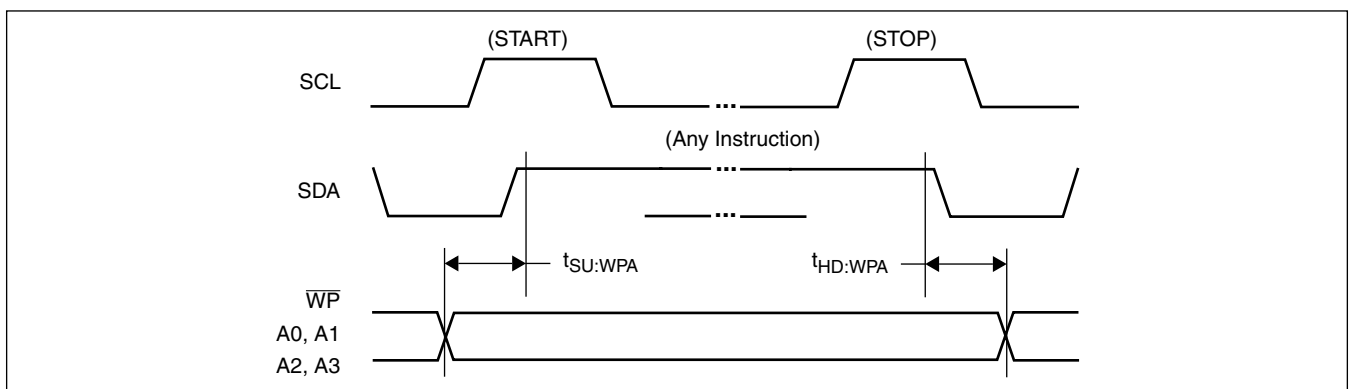

# X9448

## AC Timing

Symbol	Parameter	Min.	Max.	Unit
$f_{SCL}$	Clock frequency		400	kHz
$t_{CYC}$	Clock cycle time	2500		ns
$t_{HIGH}$	Clock high time	600		ns
$t_{LOW}$	Clock low time	1300		ns
$t_{SU:STA}$	Start setup time	600		ns
$t_{HD:STA}$	Start hold time	600		ns
$t_{SU:STO}$	Stop setup time	600		ns
$t_{SU:DAT}$	SDA data input setup time	100		ns
$t_{HD:DAT}^{(4)}$	SDA data input hold time	0/30		ns
$t_R$	SCL and SDA rise time		300	ns
$t_F$	SCL and SDA fall time		300	ns
$t_{AA}$	SCL low to SDA data output valid time	100	900	ns
$t_{DH}$	SDA Data output hold time	50		ns
$T_I$	Noise suppression time constant at SCL and SDA inputs	50		ns
$t_{BUF}$	Bus free time (prior to any transmission)	1300		ns
$t_{SU:WPA}$	$\overline{WP}$ , A0, A1, A2 and A3 setup time	0		ns
$t_{HD:WPA}$	$\overline{WP}$ , A0, A1, A2 and A3 hold time	0		ns

## High-Voltage Write Cycle Timing

Symbol	Parameter	Typ.	Max.	Unit
$t_{WR}$	High-voltage write cycle time (store instructions)	5	10	ms

## XDCP Timing

Symbol	Parameter	Min.	Max.	Unit
$t_{WRL}$	Wiper response time after instruction issued (all load instructions)		10	$\mu$ s

Note: (4)  $V_{CC} = 5V/2.7V$

# X9448

## BASIC APPLICATIONS

### Programmable Level Detector with Memory (typical bias conditions)

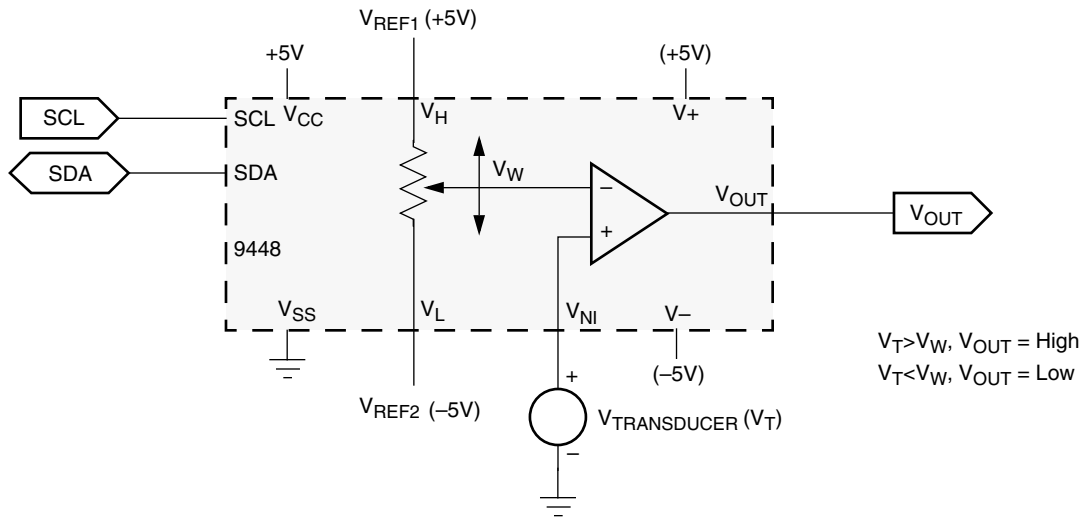

### Programmable Window Detector with Memory

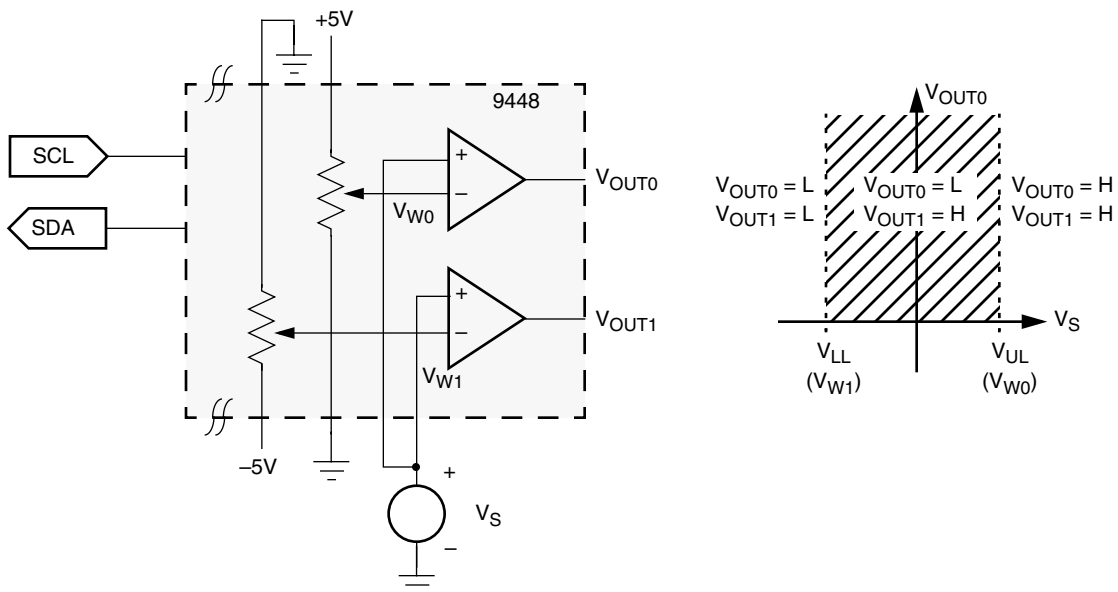

For the signal voltage  $V_S > \text{the upper limit } V_{UL}, (V_{OUT0} = H) \cdot (V_{OUT1} = H)$   
 $V_S < \text{the lower limit } V_{LL}, (V_{OUT0} = L) \cdot (V_{OUT1} = L)$

For the window  $V_{LL} \leq V_S \leq V_{UL}, (V_{OUT0} = L) \cdot (V_{OUT1} = H)$

# X9448

## BASIC APPLICATION (continued)

### Programmable Oscillator with Memory

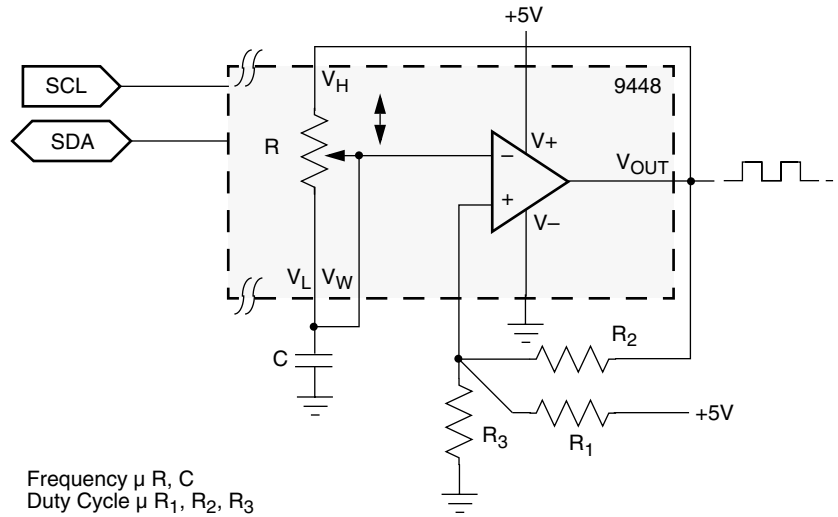

### Programmable Schmitt Trigger with Memory

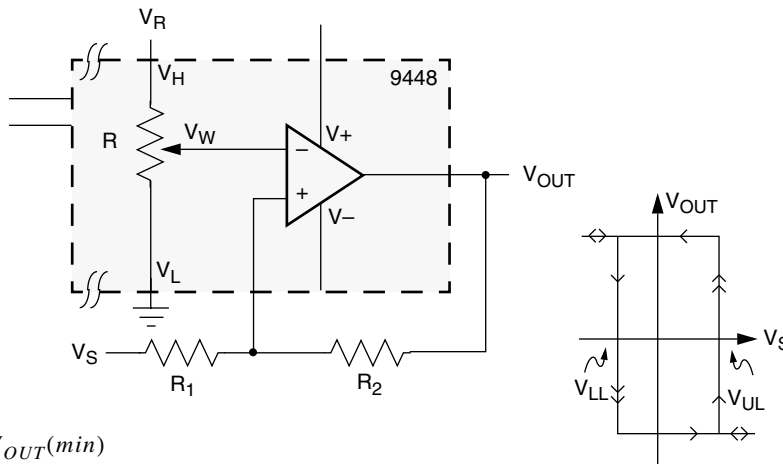

$$V_{UL} = \frac{R_1 + R_2}{R_2} V_W - \frac{R_1}{R_2} V_{OUT(min)}$$

$$V_{LL} = \frac{R_1 + R_2}{R_2} V_W - \frac{R_1}{R_2} V_{OUT(max)}$$



**BASIC APPLICATION (continued)**

**Programmable Level Detector (alternate technique)**

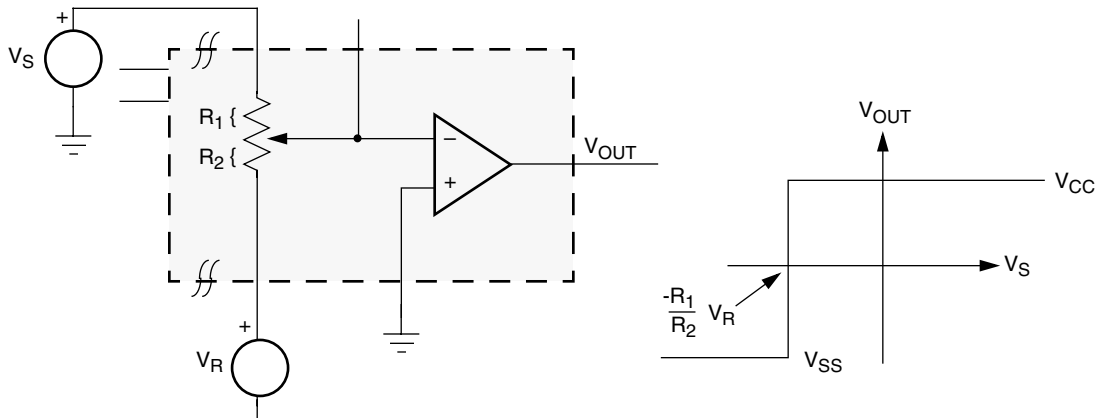

$$V_{OUT} = \text{High for } V_S < -\frac{R_1}{R_2} V_R$$

$$V_{OUT} = \text{Low for } V_S > -\frac{R_1}{R_2} V_R$$

$$R_1 + R_2 = R_{POT}$$

**Programmable Time Delay with Memory**

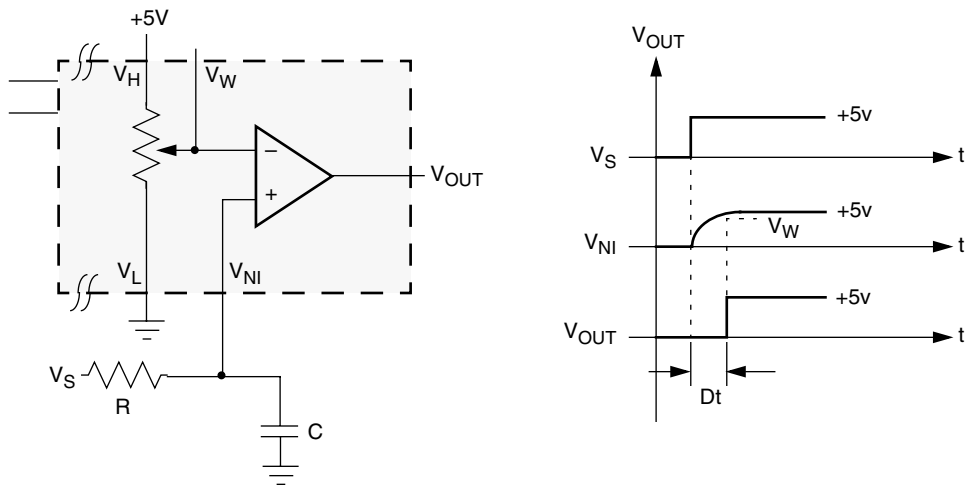

$$\Delta t = RC \ln\left(\frac{5V}{5V - V_W}\right)$$

# X9448

## PACKAGING INFORMATION

### 24-Lead Plastic Small Outline Gull Wing Package Type S

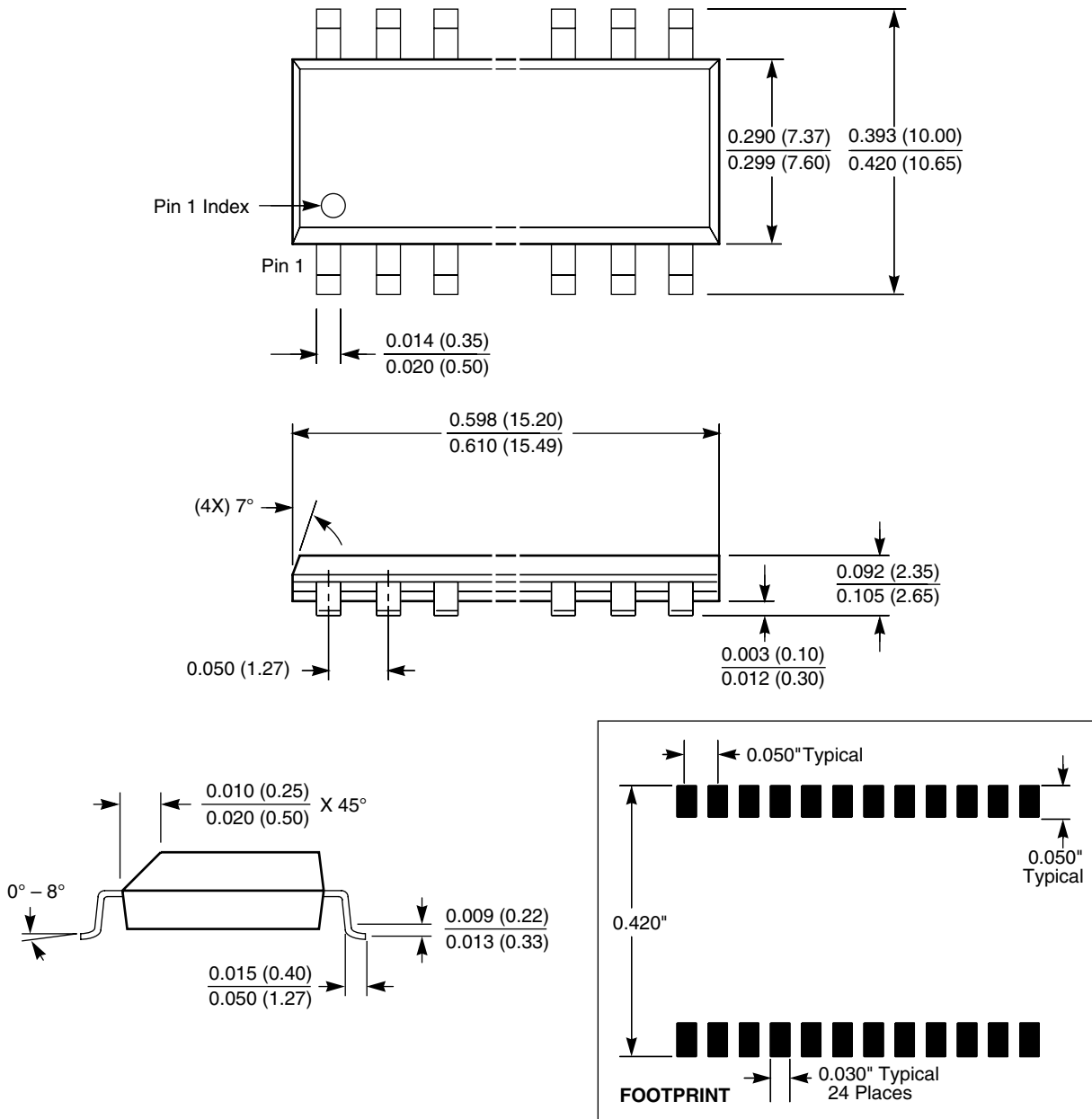

**NOTE: ALL DIMENSIONS IN INCHES (IN PARENTHESES IN MILLIMETERS)**

PACKAGING INFORMATION

24-Lead Plastic, TSSOP Package Type V

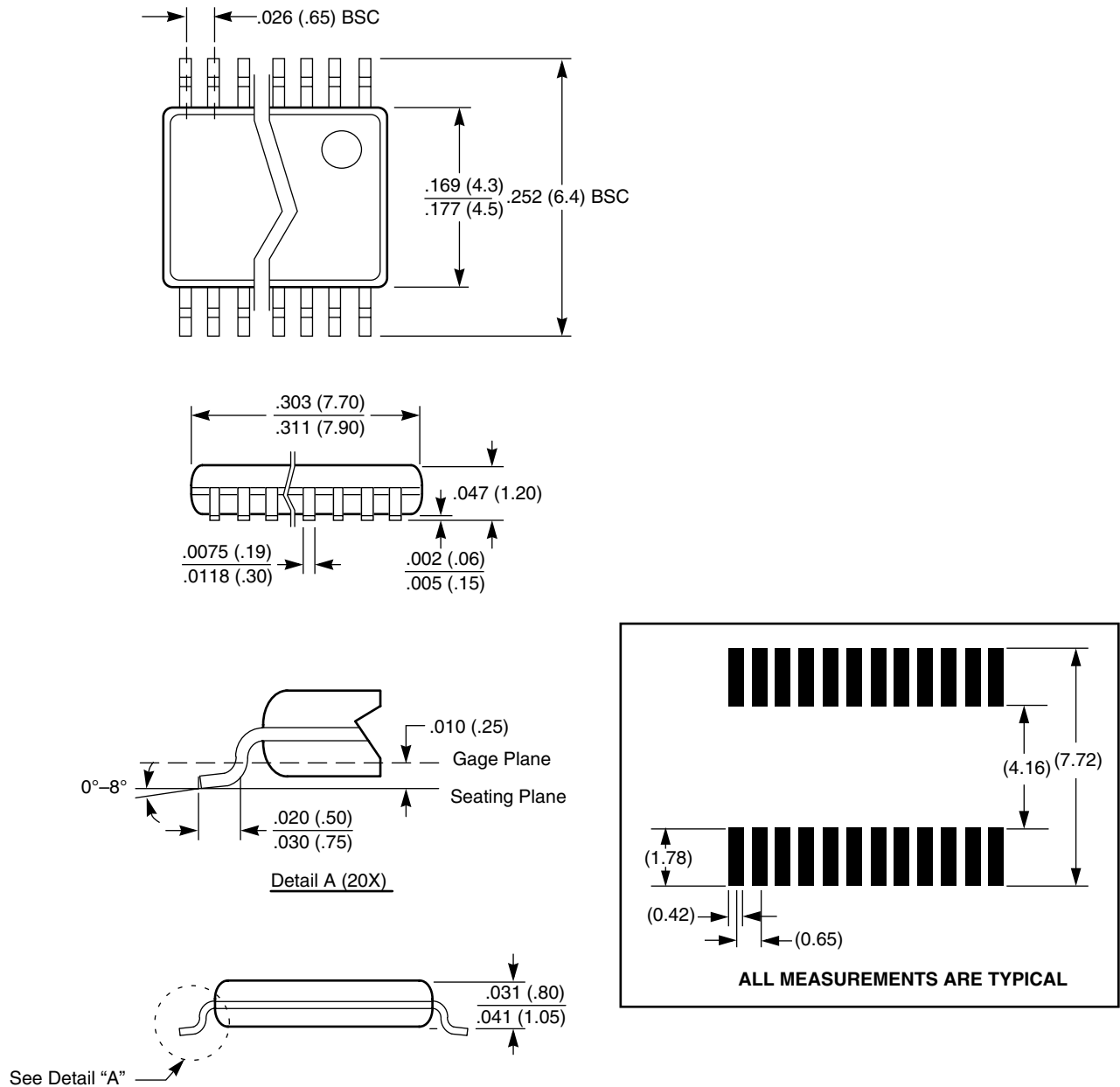

NOTE: ALL DIMENSIONS IN INCHES (IN PARENTHESES IN MILLIMETERS)

# X9448

## ORDERING INFORMATION

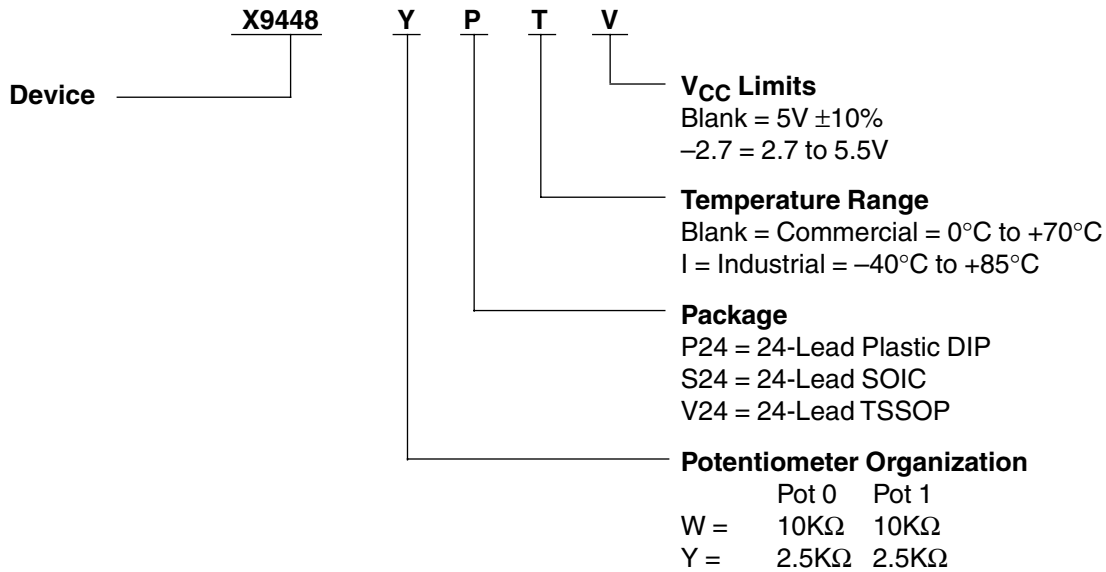

### LIMITED WARRANTY

©Xicor, Inc. 2000 Patents Pending

Devices sold by Xicor, Inc. are covered by the warranty and patent indemnification provisions appearing in its Terms of Sale only. Xicor, Inc. makes no warranty, express, statutory, implied, or by description regarding the information set forth herein or regarding the freedom of the described devices from patent infringement. Xicor, Inc. makes no warranty of merchantability or fitness for any purpose. Xicor, Inc. reserves the right to discontinue production and change specifications and prices at any time and without notice.

Xicor, Inc. assumes no responsibility for the use of any circuitry other than circuitry embodied in a Xicor, Inc. product. No other circuits, patents, or licenses are implied.

### TRADEMARK DISCLAIMER:

Xicor and the Xicor logo are registered trademarks of Xicor, Inc. AutoStore, Direct Write, Block Lock, SerialFlash, MPS, and XDCP are also trademarks of Xicor, Inc. All others belong to their respective owners.

### U.S. PATENTS

Xicor products are covered by one or more of the following U.S. Patents: 4,326,134; 4,393,481; 4,404,475; 4,450,402; 4,486,769; 4,488,060; 4,520,461; 4,533,846; 4,599,706; 4,617,652; 4,668,932; 4,752,912; 4,829,482; 4,874,967; 4,883,976; 4,980,859; 5,012,132; 5,003,197; 5,023,694; 5,084,667; 5,153,880; 5,153,691; 5,161,137; 5,219,774; 5,270,927; 5,324,676; 5,434,396; 5,544,103; 5,587,573; 5,835,409; 5,977,585. Foreign patents and additional patents pending.

### LIFE RELATED POLICY

In situations where semiconductor component failure may endanger life, system designers using this product should design the system with appropriate error detection and correction, redundancy and back-up features to prevent such an occurrence.

Xicor's products are not authorized for use in critical components in life support devices or systems.

1. Life support devices or systems are devices or systems which, (a) are intended for surgical implant into the body, or (b) support or sustain life, and whose failure to perform, when properly used in accordance with instructions for use provided in the labeling, can be reasonably expected to result in a significant injury to the user.
2. A critical component is any component of a life support device or system whose failure to perform can be reasonably expected to cause the failure of the life support device or system, or to affect its safety or effectiveness.