

Digitally Controlled Potentiometer (XDCP™)

The Intersil X93155 is a digitally controlled potentiometer (XDCP). The device consists of a resistor array, wiper switches, a control section, and nonvolatile memory. The wiper position is controlled by a 3-wire interface.

The potentiometer is implemented by a resistor array composed of 31 resistive elements and a wiper switching network. The position of the wiper element is controlled by the \overline{CS} , U/D, and INC inputs. The position of the wiper can be stored in nonvolatile memory and then be recalled upon a subsequent power-up operation.

The device is connected as a two-terminal variable resistor and can be used in a wide variety of applications including:

- Bias and Gain Control
- LCD Contrast Adjustment

Ordering Information

PART NUMBER	PART MARKING	R _{TOTAL} (kΩ)	TEMP RANGE (°C)	PACKAGE
X93155UM8I*	AGM	50	-40 to 85	8 Ld MSOP
X93155UM8IZ* (Note)	DCH	50	-40 to 85	8 Ld MSOP (Pb-free)

*Add "T1" suffix for tape and reel.

NOTE: Intersil Pb-free plus anneal products employ special Pb-free material sets; molding compounds/die attach materials and 100% matte tin plate termination finish, which are RoHS compliant and compatible with both SnPb and Pb-free soldering operations. Intersil Pb-free products are MSL classified at Pb-free peak reflow temperatures that meet or exceed the Pb-free requirements of IPC/JEDEC J STD-020.

Features

- Solid-state potentiometer
- Up/Down interface
- 32 wiper tap points per potentiometer
 - Wiper position stored in nonvolatile memory and recalled on power-up
- 31 resistive elements per potentiometer
 - Temperature compensated
 - Maximum resistance tolerance $\pm 25\%$
 - Terminal voltage, 0 to V_{CC}
- Low power CMOS
 - $V_{CC} = 5V \pm 10\%$
 - Active current, 200 μ A typ.
 - Standby current, 2.0 μ A max
- High reliability
 - Endurance 200,000 data changes per bit
 - Register data retention, 100 years
- R_{TOTAL} value = 50kΩ
- Packages
 - 8 Ld MSOP
- Pb-free plus anneal available (RoHS compliant)

Pinout

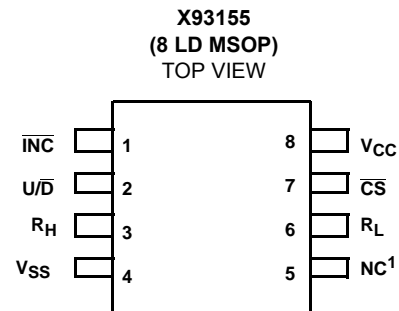

¹NC can be left unconnected, or connected to any voltage between V_{SS} and V_{CC} .

Block Diagram

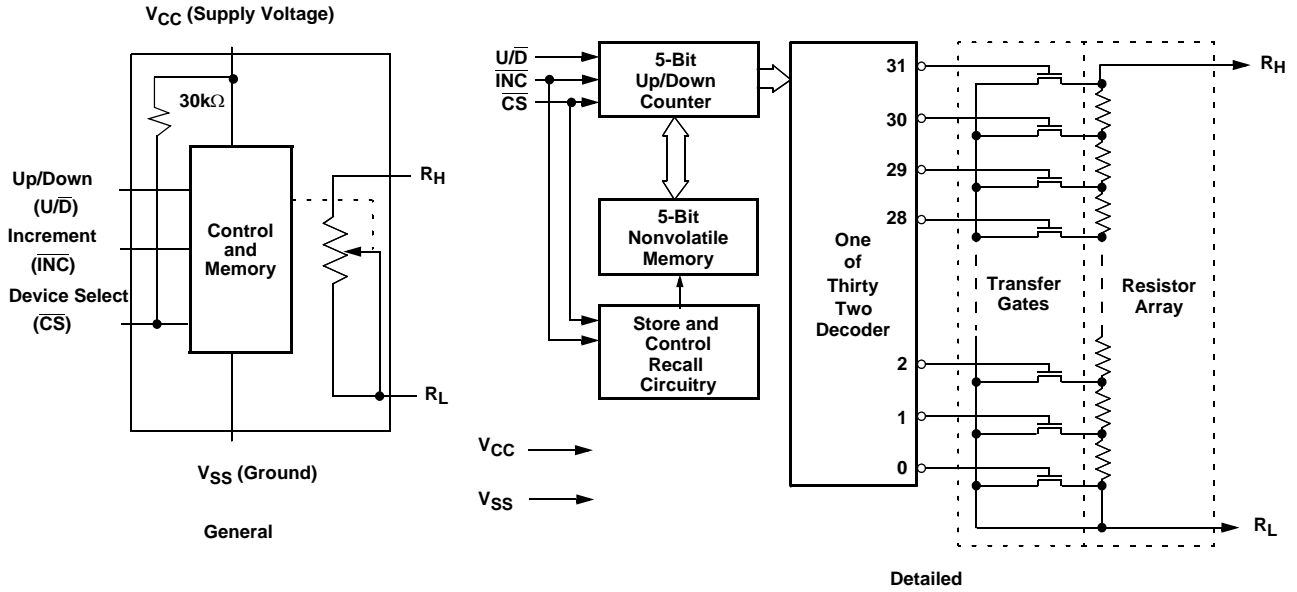

Pin Descriptions

MSOP	SYMBOL	BRIEF DESCRIPTION
1	$\overline{\text{INC}}$	Increment ($\overline{\text{INC}}$). The $\overline{\text{INC}}$ input is negative-edge triggered. Toggling $\overline{\text{INC}}$ will move the wiper and either increment or decrement the counter in the direction indicated by the logic level on the $\text{U}/\overline{\text{D}}$ input.
2	$\text{U}/\overline{\text{D}}$	Up/Down ($\text{U}/\overline{\text{D}}$). The $\text{U}/\overline{\text{D}}$ input controls the direction of the wiper movement and whether the counter is incremented or decremented.
3	R_H	R_H. The R_H and R_L pins of the X93155 are equivalent to the end terminals of a variable resistor.
4	V_SS	Ground.
5	NC	No Connection. (or can be connected to any voltage between V_SS and V_CC .)
6	R_L	R_L. The R_H and R_L pins of the X93155 are equivalent to the end terminals of a variable resistor.
7	$\overline{\text{CS}}$	Chip Select ($\overline{\text{CS}}$). The device is selected when the $\overline{\text{CS}}$ input is LOW. The current counter value is stored in nonvolatile memory when $\overline{\text{CS}}$ is returned HIGH while the $\overline{\text{INC}}$ input is also HIGH. After the store operation is complete, the X93155 will be placed in the low power standby mode until the device is selected once again.
8	V_CC	Supply Voltage.

Absolute Maximum Ratings

Temperature under bias -65°C to +135°C
 Storage temperature -65°C to +150°C
 Voltage on CS, INC, U/D, RH, RL and VCC
 with respect to VSS -1V to +6.5V
 Lead temperature (soldering 10 seconds) 300°C
 Maximum reflow temperature (40 seconds) 240°C
 Maximum resistor current 2mA

Recommended Operating Conditions

Temperature Range
 Industrial -40°C to +85°C
 Supply Voltage
 VCC 5V ±10%⁽⁷⁾

CAUTION: Stresses above those listed under "Absolute Maximum Ratings" may cause permanent damage to the device. This is a stress rating only; the functional operation of the device (at these or any other conditions above those listed in the operational sections of this specification) is not implied. Exposure to absolute maximum rating conditions for extended periods may affect device reliability.

Potentiometer Specifications Over recommended operating conditions unless otherwise stated.

SYMBOL	PARAMETER	TEST CONDITIONS/NOTES	MIN	TYP	MAX	UNIT
RTOT	End to end resistance		37.5	50	62.5	kΩ
VR	RH, RL terminal voltages		0		VCC	V
	Power rating	RTOTAL = 50kΩ			1	mW ⁽⁶⁾
	Noise	Ref: 1kHz		-120		dBV ⁽⁶⁾
IR	Potentiometer Current	(5)			0.6	mA
	Resolution			3		%
	Absolute linearity ⁽¹⁾	RH(n)(actual)-RH(n)(expected)			±1	MI ⁽³⁾
	Relative linearity ⁽²⁾	RH(n+1)-[RH(n)+MI]			±0.5	MI ⁽³⁾
	RTOTAL temperature coefficient	(6)			±35	ppm/°C
CH/CL/CW	Potentiometer capacitances	See circuit #2		10/10/25		pF ⁽⁶⁾

- Notes: (1) Absolute linearity is utilized to determine actual wiper resistance versus expected resistance = (RH(n)(actual)-RH(n)(expected)) = ±1 MI Maximum. n = 1 .. 29 only
 (2) Relative linearity is a measure of the error in step size between taps = RH(n+1)-[RH(n) + MI] = ±0.5 MI, n = 1 .. 29 only.
 (3) 1 MI = Minimum Increment = RTOT/31.
 (4) Typical values are for TA = 25°C and nominal supply voltage.
 (5) This parameter is periodically sampled and not 100% tested
 (6) This parameter is not 100% tested.
 (7) When performing multiple write operations, VCC must not decrease by more than 150mV from its initial value.

DC Electrical Specifications Over recommended operating conditions unless otherwise specified.

SYMBOL	PARAMETER	TEST CONDITIONS	MIN	TYP (4)	MAX	UNIT
ICC1	VCC active current (Increment)	CS = VIL, U/D = VIL or VIH and INC = 0.4V @ max. tCYC		200	300	μA
ICC2	VCC active current (Store) (EEPROM Store)	CS = VIH, U/D = VIL or VIH and INC = VIH @ max. tWR			1400	μA
ISB	Standby supply current	CS = VCC - 0.3V, U/D and INC = VSS or VCC - 0.3V			2.0	μA
ILI	CS	VCS = VCC			±1	μA
ILI	CS	VCC = 5V, CS = 0	120	200	250	μA
ILI	INC, U/D input leakage current	VIN = VSS to VCC			±1	μA
VIH	CS, INC, U/D input HIGH voltage		VCC x 0.7		VCC + 0.5	V
VIL	CS, INC, U/D input LOW voltage		-0.5		VCC x 0.1	V
CIN ⁽⁵⁾⁽⁷⁾	CS, INC, U/D input capacitance	VCC = 5V, VIN = VSS, TA = 25°C, f = 1MHz			10	pF

Endurance and Data Retention

PARAMETER	MIN	UNIT
Minimum endurance	200,000	Data changes per bit
Data retention	100	Years

Test Circuit #1

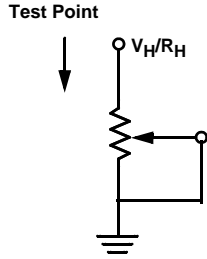

Circuit #2 SPICE Macro Model

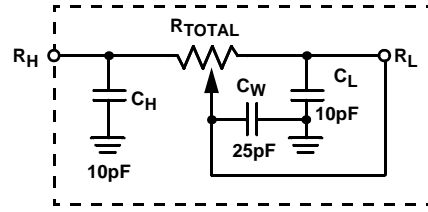

A.C. Conditions of Test

Input pulse levels	0V to 5V
Input rise and fall times	10ns
Input reference levels	1.5V

AC Electrical Specifications Over recommended operating conditions unless otherwise specified.

SYMBOL	PARAMETER	MIN	TYP (6)	MAX	UNIT
t_{CI}	\overline{CS} to \overline{INC} setup	100			ns
t_{ID}	\overline{INC} HIGH to U/\overline{D} change	100			ns
t_{DI}	U/\overline{D} to \overline{INC} setup	100			ns
t_{IL}	\overline{INC} LOW period	1			μs
t_{IH}	\overline{INC} HIGH period	1			μs
t_{IC}	\overline{INC} Inactive to \overline{CS} inactive	1			μs
t_{CPH}	\overline{CS} Deselect time (NO STORE)	250			ns
t_{CPH}	\overline{CS} Deselect time (STORE)	10			ms
t_{CYC}	\overline{INC} cycle time	2			μs
$t_R, t_F^{(6)}$	\overline{INC} input rise and fall time			500	μs
$t_R V_{CC}^{(6)}$	V_{CC} power-up rate	1		10,000	V/ms
t_{WR}	Store cycle		5	10	ms

Power Up and Down Requirements

There are no restrictions on the power-up or power-down conditions of V_{CC} and the voltages applied to the potentiometer pins provided that V_{CC} is always more positive than or equal to V_H and V_L , i.e., $V_{CC} \geq V_H, V_L$. The V_{CC} ramp rate spec is always in effect.

A.C. Timing

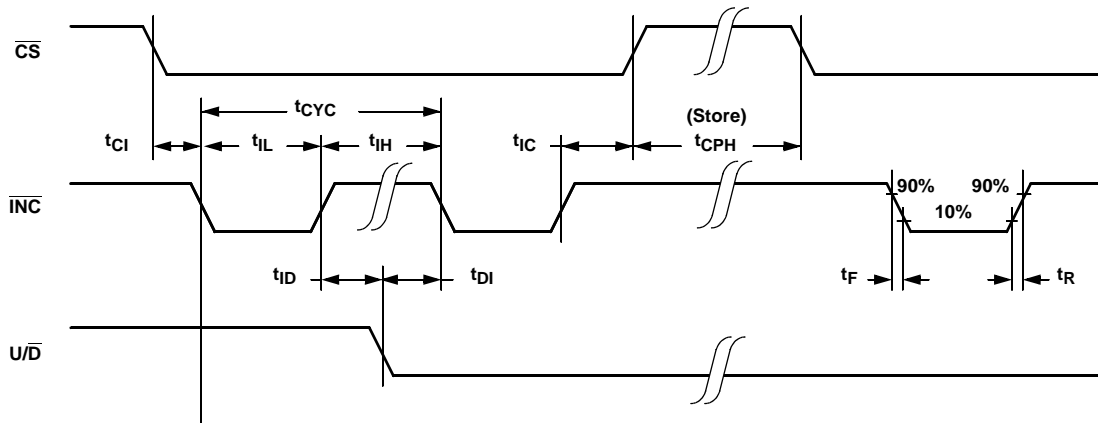

Pin Descriptions

R_H and R_L

The R_H and R_L pins of the X93155 are equivalent to the end terminals of a variable resistor. The minimum voltage is V_{SS} and the maximum is V_{CC} . The terminology of R_H and R_L references the relative position of the terminal in relation to wiper movement direction selected by the U/\bar{D} input.

Up/Down (U/\bar{D})

The U/\bar{D} input controls the direction of the wiper movement and whether the counter is incremented or decremented.

Increment (\bar{INC})

The \bar{INC} input is negative-edge triggered. Toggling \bar{INC} will move the wiper and either increment or decrement the counter in the direction indicated by the logic level on the U/\bar{D} input.

Chip Select (\bar{CS})

The device is selected when the \bar{CS} input is LOW. The current counter value is stored in nonvolatile memory when \bar{CS} is returned HIGH while the \bar{INC} input is also HIGH. After the store operation is complete the X93155 will be placed in the low power standby mode until the device is selected once again.

Principles of Operation

There are three sections of the X93155: the input control, counter and decode section; the nonvolatile memory; and the resistor array. The input control section operates just like an up/down counter. The output of this counter is decoded to turn on a single electronic switch connecting a point on the resistor array to the wiper output. Under the proper conditions the contents of the counter can be stored in nonvolatile memory and retained for future use. The resistor array is comprised of 31 individual resistors connected in series. At either end of the array and between each resistor is an electronic switch that transfers the connection at that

point to the wiper. The wiper is connected to the R_L terminal, forming a variable resistor from R_H to R_L .

The wiper, when at either fixed terminal, acts like its mechanical equivalent and does not move beyond the last position. That is, the counter does not wrap around when clocked to either extreme.

If the wiper is moved several positions, multiple taps are connected to the wiper for up to $10\mu s$. The 2-terminal resistance value for the device can temporarily change by a significant amount if the wiper is moved several positions.

When the device is powered-down, the last wiper position stored will be maintained in the nonvolatile memory. When power is restored, the contents of the memory are recalled and the wiper is set to the value last stored.

Instructions and Programming

The \bar{INC} , U/\bar{D} and \bar{CS} inputs control the movement of the wiper along the resistor array. With \bar{CS} set LOW the device is selected and enabled to respond to the U/\bar{D} and \bar{INC} inputs. HIGH to LOW transitions on \bar{INC} will increment or decrement (depending on the state of the U/\bar{D} input) a five bit counter. The output of this counter is decoded to select one of thirty two wiper positions along the resistive array.

The value of the counter is stored in nonvolatile memory whenever \bar{CS} transitions HIGH while the \bar{INC} input is also HIGH. In order to avoid an accidental store during power-up, \bar{CS} must go HIGH with V_{CC} during initial power-up. When left open, the \bar{CS} pin is internally pulled up to V_{CC} by an internal $30k\Omega$ resistor.

The system may select the X93155, move the wiper and deselect the device without having to store the latest wiper position in nonvolatile memory. After the wiper movement is performed as described above and once the new position is reached, the system must keep \bar{INC} LOW while taking \bar{CS} HIGH. The new wiper position will be maintained until

changed by the system or until a power-up/down cycle recalled the previously stored data. In order to recall the stored position of the wiper on power-up, the \overline{CS} pin must be held HIGH.

This procedure allows the system to always power-up to a preset value stored in nonvolatile memory; then during system operation minor adjustments could be made. The adjustments might be based on user preference, system parameter changes due to temperature drift, or other system trim requirements.

The state of U/\overline{D} may be changed while \overline{CS} remains LOW. This allows the host system to enable the device and then move the wiper up and down until the proper trim is attained.

Mode Selection

\overline{CS}	\overline{INC}	U/\overline{D}	MODE
L		H	Wiper Up
L		L	Wiper Down
	H	X	Store Wiper Position
H	X	X	Standby Current
	L	X	No Store, Return to Standby
	L	H	Wiper Up (not recommended)
	L	L	Wiper Down (not recommended)

Symbol Table

WAVEFORM	INPUTS	OUTPUTS
	Must be steady	Will be steady
	May change from Low to High	Will change from Low to High
	May change from High to Low	Will change from High to Low
	Don't Care: Changes Allowed	Changing: State Not Known
	N/A	Center Line is High Impedance

Applications Information

Electronic digitally controlled (XDCP) potentiometers provide three powerful application advantages; (1) the variability and reliability of a solid-state potentiometer (2) the flexibility of computer-based digital controls, and (3) the retentivity of nonvolatile memory used for the storage of multiple potentiometer settings or data.

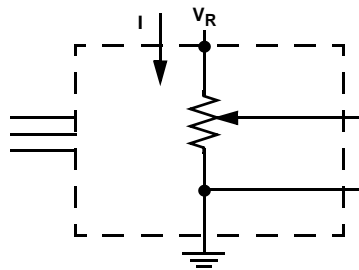

Two terminal variable resistor.

Low Voltage High Impedance Instrumentation Amplifier

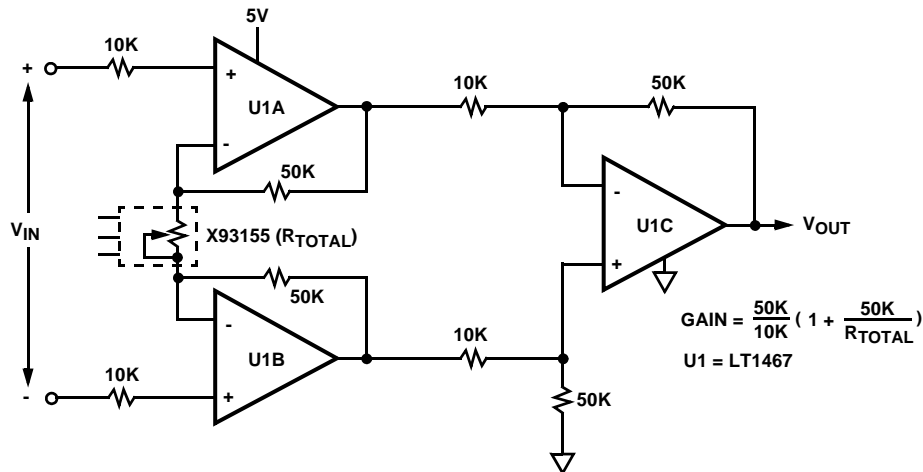

Micro-Power LCD Contrast Control

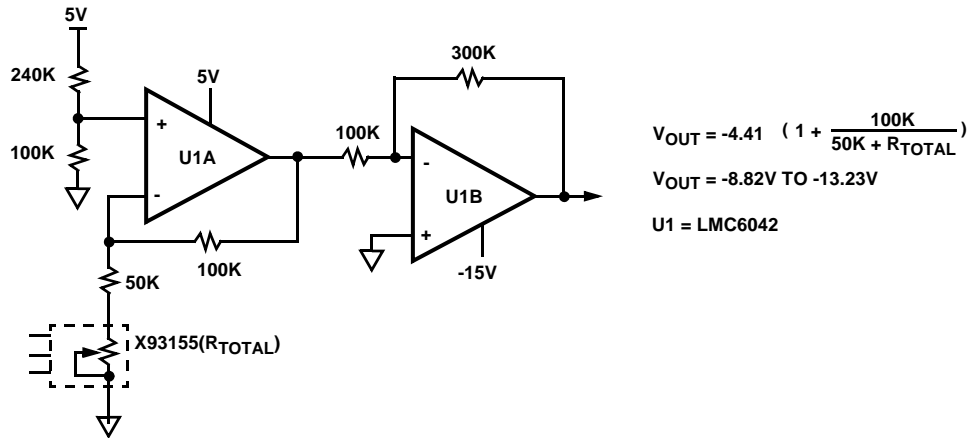

Single Supply Variable Gain Amplifier

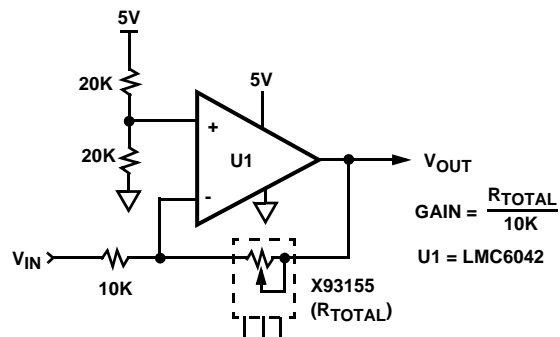

MSOP Packaging Information

8-Lead Miniature Small Outline Gull Wing Package Type M

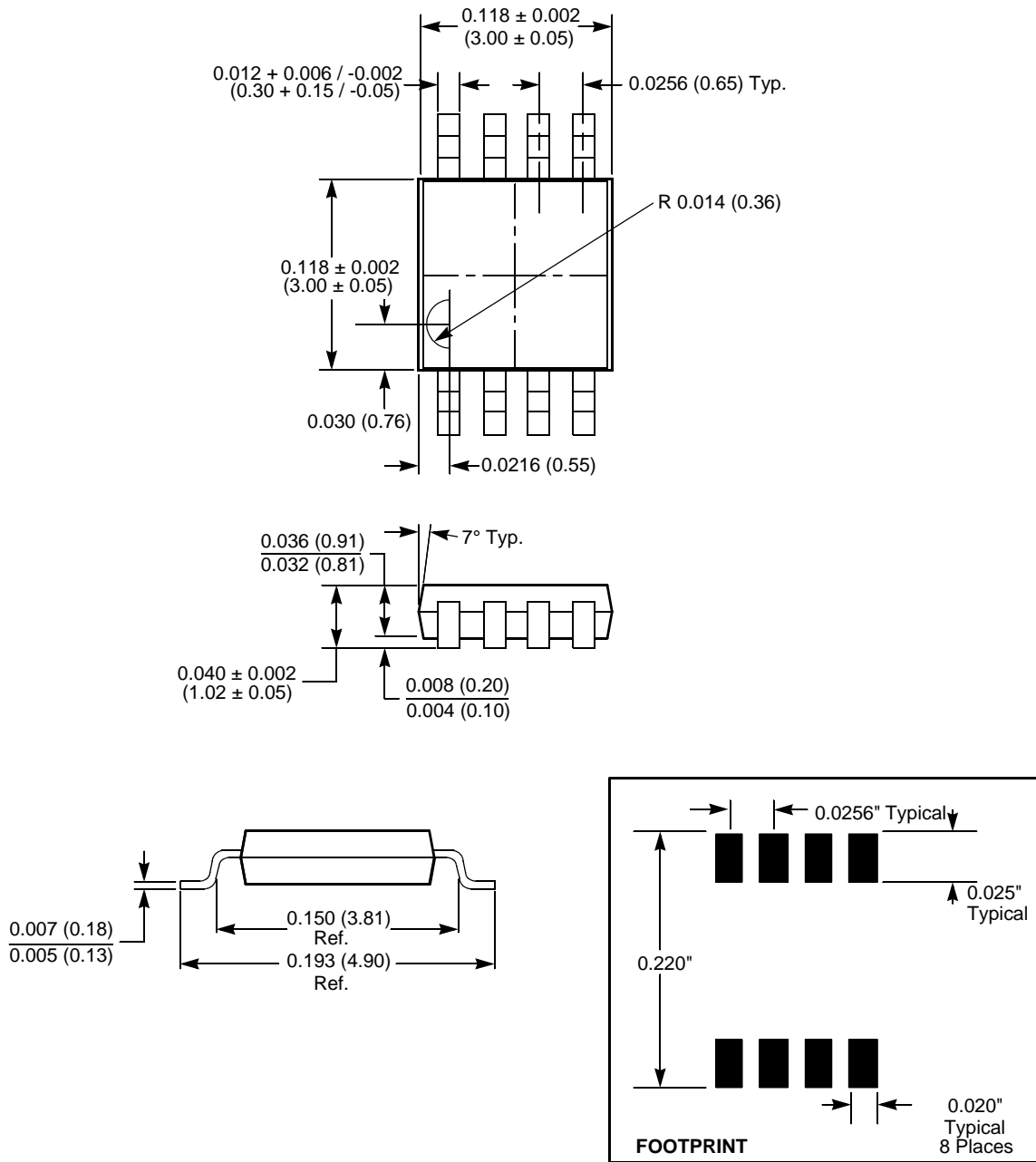

NOTE:
1. ALL DIMENSIONS IN INCHES AND (MILLIMETERS)

All Intersil U.S. products are manufactured, assembled and tested utilizing ISO9000 quality systems. Intersil Corporation's quality certifications can be viewed at www.intersil.com/design/quality

Intersil products are sold by description only. Intersil Corporation reserves the right to make changes in circuit design, software and/or specifications at any time without notice. Accordingly, the reader is cautioned to verify that data sheets are current before placing orders. Information furnished by Intersil is believed to be accurate and reliable. However, no responsibility is assumed by Intersil or its subsidiaries for its use; nor for any infringements of patents or other rights of third parties which may result from its use. No license is granted by implication or otherwise under any patent or patent rights of Intersil or its subsidiaries.

For information regarding Intersil Corporation and its products, see www.intersil.com