

**NOT RECOMMENDED FOR NEW DESIGNS  
NO RECOMMENDED REPLACEMENT**  
contact our Technical Support Center at  
1-888-INTERSIL or www.intersil.com/tsc

**Digitally Controlled Potentiometer  
(XDCP™)**

**FEATURES**

- **Solid-state potentiometer**
- **3-wire serial interface**
- **Terminal voltage, 0 to +15V**
- **100 wiper tap points**
  - Wiper position stored in nonvolatile memory and recalled on power-up
- **99 resistive elements**
  - Temperature compensated
  - End to end resistance range ± 20%
- **Low power CMOS**
  - V<sub>CC</sub> = 5V
  - Active current, 3mA max.
  - Standby current, 1mA max.
- **High reliability**
  - Endurance, 100,000 data changes per bit
  - Register data retention, 100 years
- **R<sub>TOTAL</sub> values = 10kΩ, 50kΩ, and 100kΩ**
- **Packages**
  - 8-lead SOIC and DIP

**DESCRIPTION**

The Intersil X9312 is a digitally controlled potentiometer (XDCP). The device consists of a resistor array, wiper switches, a control section, and nonvolatile memory. The wiper position is controlled by a 3-wire interface.

The potentiometer is implemented by a resistor array composed of 99 resistive elements and a wiper switching network. Between each element and at either end are tap points accessible to the wiper terminal. The position of the wiper element is controlled by the  $\overline{CS}$ ,  $\overline{U/D}$ , and  $\overline{INC}$  inputs. The position of the wiper can be stored in nonvolatile memory and then be recalled upon a subsequent power-up operation.

The device can be used as a three-terminal potentiometer or as a two-terminal variable resistor in a wide variety of applications including:

- control
- parameter adjustments
- signal processing

**BLOCK DIAGRAM**

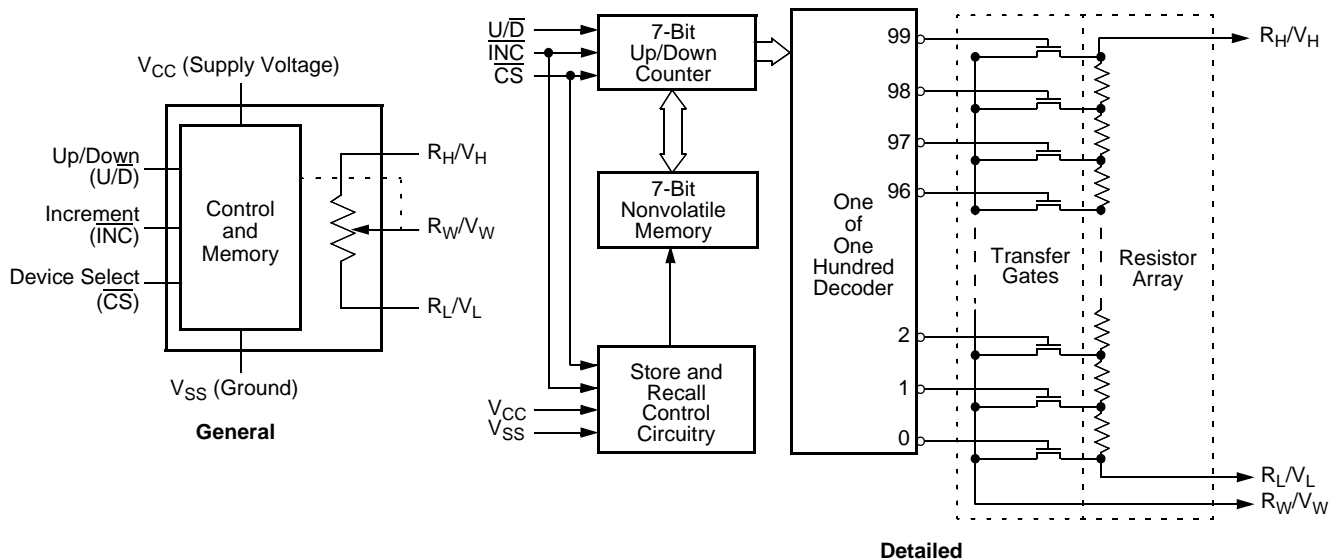

**PIN DESCRIPTIONS**

**$R_H/V_H$  and  $R_L/V_L$**

The high ( $R_H/V_H$ ) and low ( $R_L/V_L$ ) terminals of the X9312 are equivalent to the fixed terminals of a mechanical potentiometer. The minimum voltage is 0V and the maximum is +15V. The terminology of  $R_L/V_L$  and  $R_H/V_H$  references the relative position of the terminal in relation to wiper movement direction selected by the  $U/\bar{D}$  input and not the voltage potential on the terminal.

**$R_W/V_W$**

$R_W/V_W$  is the wiper terminal and is equivalent to the movable terminal of a mechanical potentiometer. The position of the wiper within the array is determined by the control inputs. The wiper terminal series resistance is typically 40Ω.

**Up/Down ( $U/\bar{D}$ )**

The  $U/\bar{D}$  input controls the direction of the wiper movement and whether the counter is incremented or decremented.

**Increment ( $\bar{INC}$ )**

The  $\bar{INC}$  input is negative-edge triggered. Toggling  $\bar{INC}$  will move the wiper and either increment or decrement the counter in the direction indicated by the logic level on the  $U/\bar{D}$  input.

**Chip Select ( $\bar{CS}$ )**

The device is selected when the  $\bar{CS}$  input is LOW. The current counter value is stored in nonvolatile memory when  $\bar{CS}$  is returned HIGH while the  $\bar{INC}$  input is also HIGH. After the store operation is complete the X9312 will be placed in the low power standby mode until the device is selected once again.

**PIN CONFIGURATION**

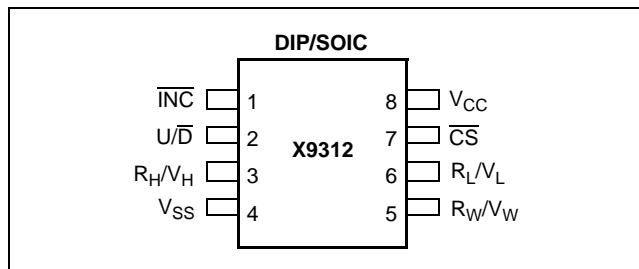

**PIN NAMES**

Symbol	Description
$R_H/V_H$	High terminal
$R_W/V_W$	Wiper terminal
$R_L/V_L$	Low terminal
$V_{SS}$	Ground
$V_{CC}$	Supply voltage
$U/\bar{D}$	Up/Down control input
$\bar{INC}$	Increment control input
$\bar{CS}$	Chip select control input

**PRINCIPLES OF OPERATION**

There are three sections of the X9312: the input control, counter and decode section; the nonvolatile memory; and the resistor array. The input control section operates just like an up/down counter. The output of this counter is decoded to turn on a single electronic switch connecting a point on the resistor array to the wiper output. Under the proper conditions the contents of the counter can be stored in nonvolatile memory and retained for future use. The resistor array is comprised of 99 individual resistors connected in series. At either end of the array and between each resistor is an electronic switch that transfers the potential at that point to the wiper.

The wiper, when at either fixed terminal, acts like its mechanical equivalent and does not move beyond the last position. That is, the counter does not wrap around when clocked to either extreme.

The electronic switches on the device operate in a “make before break” mode when the wiper changes tap positions. If the wiper is moved several positions, multiple taps are connected to the wiper for  $t_{1W}$  ( $\bar{INC}$  to  $V_W$  change). The  $R_{TOTAL}$  value for the device can temporarily be reduced by a significant amount if the wiper is moved several positions.

When the device is powered-down, the last wiper position stored will be maintained in the nonvolatile memory. When power is restored, the contents of the memory are recalled and the wiper is set to the value last stored.

**INSTRUCTIONS AND PROGRAMMING**

The  $\overline{INC}$ ,  $U/\overline{D}$  and  $\overline{CS}$  inputs control the movement of the wiper along the resistor array. With  $\overline{CS}$  set LOW the device is selected and enabled to respond to the  $U/\overline{D}$  and  $\overline{INC}$  inputs. HIGH to LOW transitions on  $\overline{INC}$  will increment or decrement (depending on the state of the  $U/\overline{D}$  input) a seven bit counter. The output of this counter is decoded to select one of one hundred wiper positions along the resistive array.





The value of the counter is stored in nonvolatile memory whenever  $\overline{CS}$  transitions HIGH while the  $\overline{INC}$  input is also HIGH.

The system may select the X9312, move the wiper and deselect the device without having to store the latest wiper position in nonvolatile memory. After the wiper movement is performed as described above and once the new position is reached, the system must keep  $\overline{INC}$  LOW while taking  $\overline{CS}$  HIGH. The new wiper position will be maintained until changed by the system or until a powerup/down cycle recalled the previously stored data.





This procedure allows the system to always power-up to a preset value stored in nonvolatile memory; then during system operation minor adjustments could be made. The adjustments might be based on user preference, system parameter changes due to temperature drift, etc...

The state of  $U/\overline{D}$  may be changed while  $\overline{CS}$  remains LOW. This allows the host system to enable the device and then move the wiper up and down until the proper trim is attained.

**MODE SELECTION**

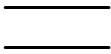
$\overline{CS}$	$\overline{INC}$	$U/\overline{D}$	Mode
L		H	Wiper up
L		L	Wiper down
	H	X	Store wiper position
H	X	X	Standby current
	L	X	No store, return to standby

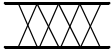
**SYMBOL TABLE**

WAVEFORM	INPUTS	OUTPUTS
	Must be steady	Will be steady
	May change from Low to High	Will change from Low to High
	May change from High to Low	Will change from High to Low
	Don't Care: Changes Allowed	Changing: State Not Known
	N/A	Center Line is High Impedance

**ABSOLUTE MAXIMUM RATINGS**

Temperature under bias ..... -65°C to +135°C  
 Storage temperature ..... -65°C to +150°C  
 Voltage on  $\overline{CS}$ ,  $\overline{INC}$ ,  $U/\overline{D}$  and  $V_{CC}$   
 with respect to  $V_{SS}$  ..... -1V to +7V  
 $\Delta V = |V_H - V_L|$  ..... 15V  
 Lead temperature (soldering 10 seconds) ..... 300°C  
 $I_W$  (10 seconds) .....  $\pm 8.8$ mA

**COMMENT**

Stresses above those listed under “Absolute Maximum Ratings” may cause permanent damage to the device. This is a stress rating only; functional operation of the device (at these or any other conditions above those listed in the operational sections of this specification) is not implied. Exposure to absolute maximum rating conditions for extended periods may affect device reliability.

**RECOMMENDED OPERATING CONDITIONS**

Temperature	Min.	Max.
Commercial	0°C	+70°C
Industrial	-40°C	+85°C

Supply Voltage ( $V_{CC}$ )	Limits
X9312	5V $\pm 10\%$

**POTENTIOMETER CHARACTERISTICS** (Over recommended operating conditions unless otherwise stated.)

Symbol	Parameter	Limits				Test Conditions/Notes
		Min.	Typ.	Max.	Unit	
	End to end resistance tolerance			$\pm 20$	%	
$V_{VH}$	$V_H$ terminal voltage	$V_{SS}$		15	V	$V_{SS} = 0V$
$V_{VL}$	$V_L$ terminal voltage	$V_{SS}$		15	V	$V_{SS} = 0V$
	Power rating			25	mW	$R_{TOTAL} \geq 10k\Omega$
	Power rating			225	mW	$R_{TOTAL} = 1k\Omega$
$R_W$	Wiper resistance		40	100	$\Omega$	$I_W = 1mA, V_{CC} = 5V$
$I_W$	Wiper current			$\pm 4.4$	mA	
	Noise		-120		dBV	Ref: 1kHz
	Resolution		1		%	
	Absolute linearity <sup>(1)</sup>			$\pm 1$	MI <sup>(3)</sup>	$R_{W(n)(actual)} - R_{W(n)(expected)}$
	Relative linearity <sup>(2)</sup>			$\pm 0.2$	MI <sup>(3)</sup>	$R_{W(n+1)} - [R_{W(n)} + MI]$
	$R_{TOTAL}$ temperature coefficient		$\pm 300$		ppm/°C	
	Ratiometric temperature coefficient			$\pm 20$	ppm/°C	
$C_H/C_L/C_W$	Potentiometer capacitances		10/10/25		pF	See circuit #3

- Notes: (1) Absolute linearity is utilized to determine actual wiper voltage versus expected voltage =  $(V_{W(n)(actual)} - V_{W(n)(expected)}) = \pm 1$  MI Maximum.  
 (2) Relative linearity is a measure of the error in step size between taps =  $R_{W(n+1)} - [R_{W(n)} + MI] = \pm 0.2$  MI.  
 (3) 1 MI = Minimum Increment =  $R_{TOT}/99$ .

**D.C. OPERATING CHARACTERISTICS** (Over recommended operating conditions unless otherwise specified.)

Symbol	Parameter	Limits			Unit	Test Conditions
		Min.	Typ.(4)	Max.		
$I_{CC}$	$V_{CC}$ active current (Increment)		1	3	mA	$\overline{CS} = V_{IL}$ , $U/\overline{D} = V_{IL}$ or $V_{IH}$ and $INC = 0.4V/2.4V$ @ max. $t_{CYC}$
$I_{SB}$	Standby supply current		500	1000	$\mu A$	$\overline{CS} = V_{CC} - 0.3V$ , $U/\overline{D}$ and $INC = V_{SS}$ or $V_{CC} - 0.3V$
$I_{LI}$	$\overline{CS}$ , $\overline{INC}$ , $U/\overline{D}$ input leakage current			$\pm 10$	$\mu A$	$V_{IN} = V_{SS}$ to $V_{CC}$
$V_{IH}$	$\overline{CS}$ , $\overline{INC}$ , $U/\overline{D}$ input HIGH voltage	2		$V_{CC} + 1$	V	
$V_{IL}$	$\overline{CS}$ , $\overline{INC}$ , $U/\overline{D}$ input LOW voltage	-1		0.8	V	
$C_{IN}^{(5)}$	$\overline{CS}$ , $\overline{INC}$ , $U/\overline{D}$ input capacitance			10	pF	$V_{CC} = 5V$ , $V_{IN} = V_{SS}$ , $T_A = 25^\circ C$ , $f = 1MHz$

**ENDURANCE AND DATA RETENTION**

Parameter	Min.	Unit
Minimum endurance	100,000	Data changes per bit
Data retention	100	Years

Notes: (4) Typical values are for  $T_A = 25^\circ C$  and nominal supply voltage.  
 (5) This parameter is periodically sampled and not 100% tested.

**Test Circuit #1**

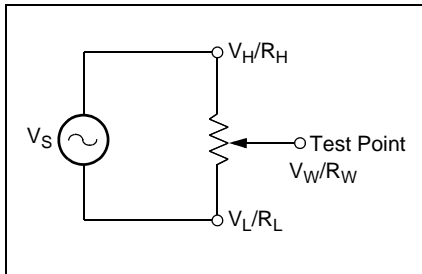

**Test Circuit #2**

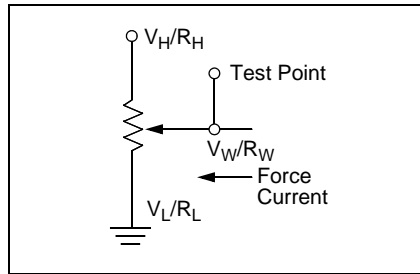

**Circuit #3 SPICE Macro Model**

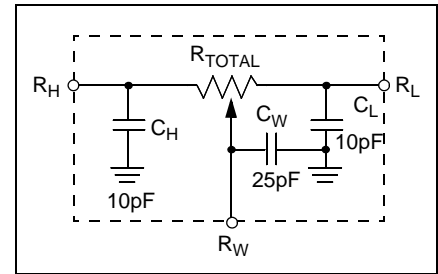

**A.C. CONDITIONS OF TEST**

Input pulse levels	0V to 3V
Input rise and fall times	10ns
Input reference levels	1.5V

**A.C. OPERATING CHARACTERISTICS** (Over recommended operating conditions unless otherwise specified)

Symbol	Parameter	Limits			Unit
		Min.	Typ. <sup>6</sup>	Max.	
$t_{CI}$	$\overline{CS}$ to $\overline{INC}$ setup	100			ns
$t_{ID}$	$\overline{INC}$ HIGH to $U/\overline{D}$ change	100			ns
$t_{DI}$	$U/\overline{D}$ to $\overline{INC}$ setup	1			$\mu$ s
$t_{IL}$	$\overline{INC}$ LOW period	1			$\mu$ s
$t_{IH}$	$\overline{INC}$ HIGH period	1			$\mu$ s
$t_C$	$\overline{INC}$ inactive to $\overline{CS}$ inactive	1			$\mu$ s
$t_{CPH}$	$\overline{CS}$ deselect time (STORE)	20			ms
$t_{CPH}$	$\overline{CS}$ deselect time (NO STORE)	100			ns
$t_{IW}$	$\overline{INC}$ to $V_w$ change		100	500	$\mu$ s
$t_{CYC}$	$\overline{INC}$ cycle time	4			$\mu$ s
$t_R, t_F^7$	$\overline{INC}$ input rise and fall time			500	$\mu$ s
$t_{PU}^7$	Power-up to wiper stable			500	$\mu$ s
$t_R V_{CC}^7$	$V_{CC}$ power-up rate	0.2		50	V/ms

**POWER-UP AND DOWN REQUIREMENTS**

There are no restrictions on the sequencing of  $V_{CC}$  and the voltages applied to the potentiometer pins during power-up or power-down conditions. During power-up, the data sheet parameters for the DCP do not fully apply until 1 millisecond after  $V_{CC}$  reaches its final value. The  $V_{CC}$  ramp spec is always in effect.

**A.C. TIMING**

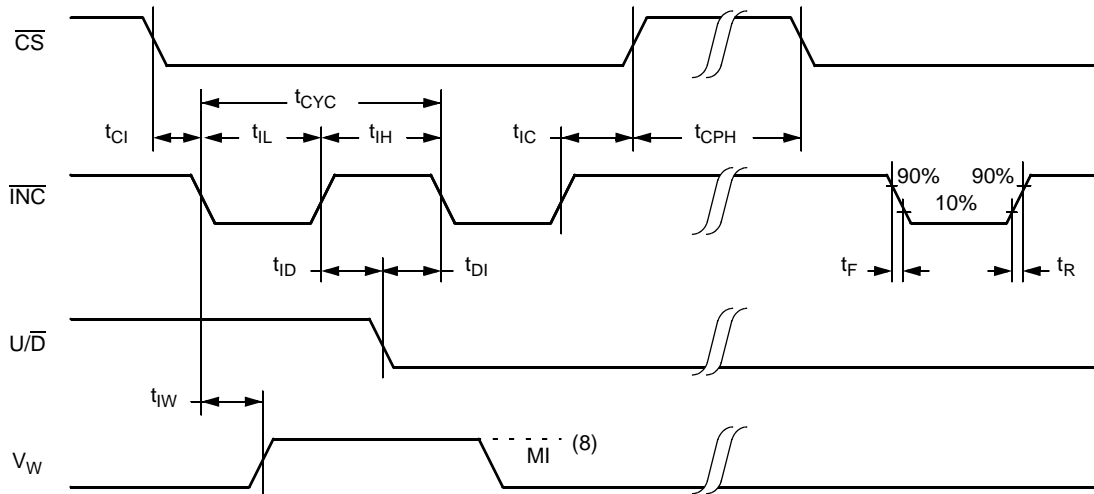

- Notes: (6) Typical values are for  $T_A = 25^\circ\text{C}$  and nominal supply voltage.
- (7) This parameter is sample tested.
- (8) MI in the A.C. timing diagram refers to the minimum incremental change in the  $V_w$  output due to a change in the wiper position.

**APPLICATIONS INFORMATION**

Electronic digitally controlled (XDCP) potentiometers provide three powerful application advantages; (1) the variability and reliability of a solid-state potentiometer, (2) the flexibility of computer-based digital controls, and (3) the retentivity of nonvolatile memory used for the storage of multiple potentiometer settings or data.

**Basic Configurations of Electronic Potentiometers**

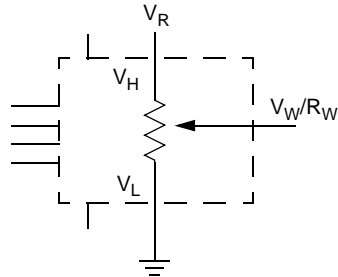

Three terminal potentiometer; variable voltage divider

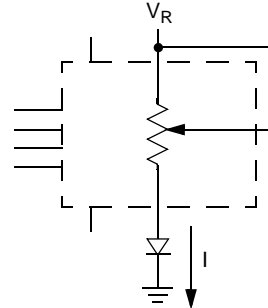

Two terminal variable resistor; variable current

**Basic Circuits**

**Buffered Reference Voltage**

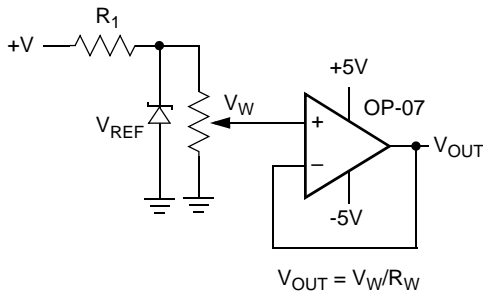

**Cascading Techniques**

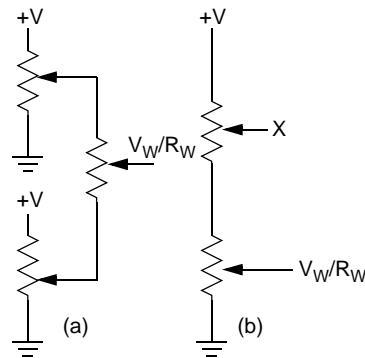

**Noninverting Amplifier**

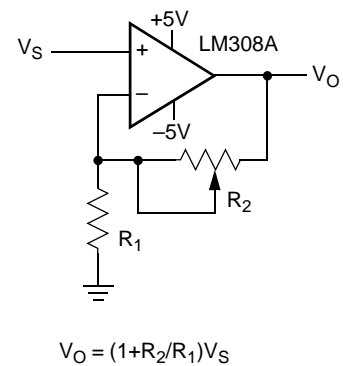

**Voltage Regulator**

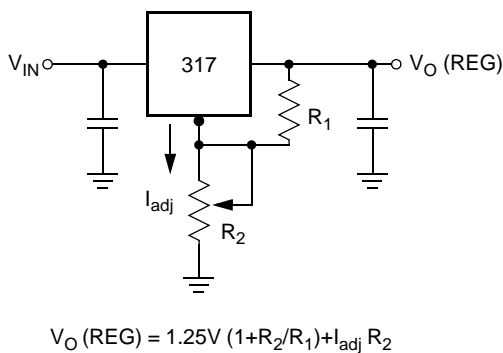

**Offset Voltage Adjustment**

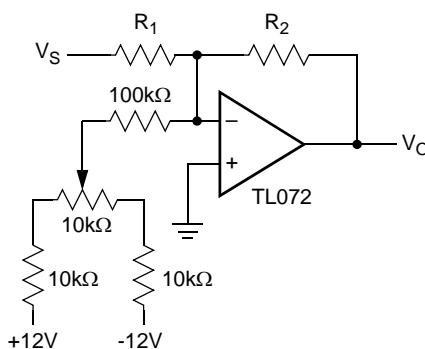

**Comparator with Hysteresis**

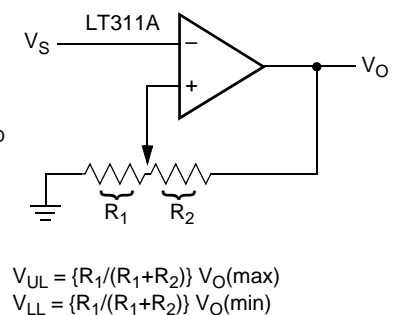

(for additional circuits see AN115)

PACKAGING INFORMATION

8-Lead Plastic Small Outline Gull Wing Package Type S

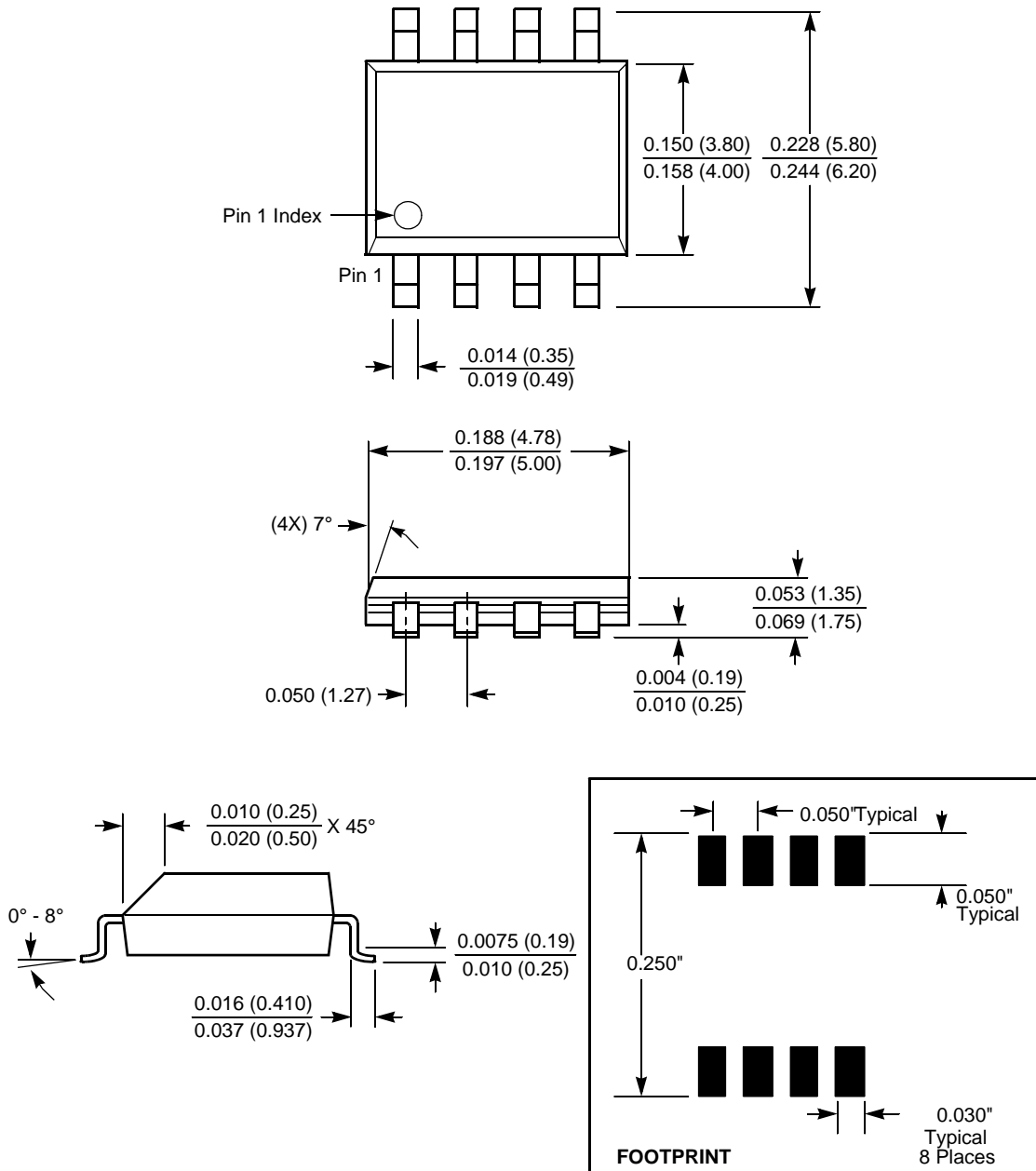

NOTE: ALL DIMENSIONS IN INCHES (IN PARENTHESES IN MILLIMETERS)



ORDERING INFORMATION

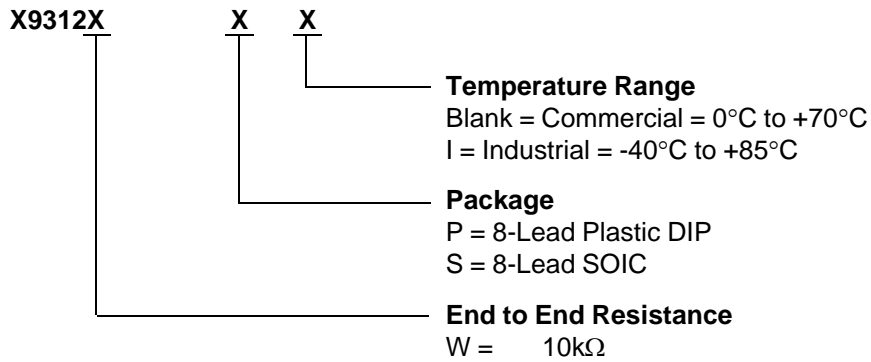

**Physical Characteristics**

Marking Includes  
Manufacturer's Trademark  
Resistance Value or Code  
Date Code

All Intersil U.S. products are manufactured, assembled and tested utilizing ISO9000 quality systems.  
Intersil Corporation's quality certifications can be viewed at [www.intersil.com/design/quality](http://www.intersil.com/design/quality)

*Intersil products are sold by description only. Intersil Corporation reserves the right to make changes in circuit design, software and/or specifications at any time without notice. Accordingly, the reader is cautioned to verify that data sheets are current before placing orders. Information furnished by Intersil is believed to be accurate and reliable. However, no responsibility is assumed by Intersil or its subsidiaries for its use; nor for any infringements of patents or other rights of third parties which may result from its use. No license is granted by implication or otherwise under any patent or patent rights of Intersil or its subsidiaries.*

For information regarding Intersil Corporation and its products, see [www.intersil.com](http://www.intersil.com)