

FEATURES

Computes true rms value instantly

Accuracy: $\pm 10 \mu\text{V} \pm 0.5\%$ of reading

Wide dynamic input range

100 μV rms to 3 V rms (8.5 V p-p) full-scale input range

Larger inputs with external scaling

Wide bandwidth:

1 MHz for -3 dB (300 mV)

65 kHz for additional 1% error

Zero converter dc output offset

No residual switching products

Specified at 300 mV rms input

Accurate conversion with crest factors up to 10

Low power: 300 μA typical at ± 2.4 V

Fast settling at all input levels

High-Z FET separately powered input buffer

$R_{\text{IN}} \geq 10^{12} \Omega$, $C_{\text{IN}} \leq 2$ pF

Precision dc output buffer

Wide supply range

Dual: ± 2.4 V to ± 18 V

Single: 4.8 V to 36 V

Small size: 4 mm \times 4 mm package

ESD protected

GENERAL DESCRIPTION

The AD8436 is a new generation, translinear precision, low power, true rms-to-dc converter that is loaded with options. It computes a precise dc equivalent of the rms value of ac waveforms, including complex patterns such as those generated by switchmode power supplies and triacs. Its accuracy spans a wide range of input levels (see Figure 2) and temperatures. The ensured accuracy of $\pm 0.5\%$ and $\leq 10 \mu\text{V}$ output offset result from the latest Analog Devices, Inc., technology. The crest factor error is $< 0.5\%$ for CF values between 1 and 10.

The AD8436 delivers instant true rms results at less cost than misleading peak, averaging, or digital solutions. There is no programming expense or processor overhead to consider, and the 4 mm \times 4 mm package easily fits into those tight applications.

On-board buffer amplifiers enable the widest range of options for any rms-to-dc converter available, regardless of cost. For minimal applications, only a single external averaging capacitor is required. The built-in high impedance FET buffer provides an interface for external attenuators, frequency compensation, or driving low impedance loads. A matched pair of internal resistors enables an easily configurable gain-of-two or more, extending the usable input range even lower. The low power, precision input buffer makes the AD8436 attractive for use in portable multi-

Rev. 0

Information furnished by Analog Devices is believed to be accurate and reliable. However, no responsibility is assumed by Analog Devices for its use, nor for any infringements of patents or other rights of third parties that may result from its use. Specifications subject to change without notice. No license is granted by implication or otherwise under any patent or patent rights of Analog Devices. Trademarks and registered trademarks are the property of their respective owners.

FUNCTIONAL BLOCK DIAGRAM

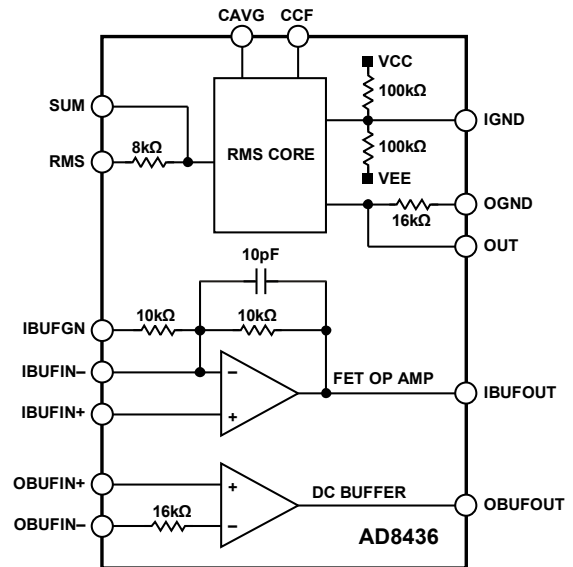

Figure 1.

meters and other battery-powered applications. The precision dc output buffer offers extremely low offset voltages, thanks to bias current cancellation.

Unlike digital solutions, the AD8436 has no switching circuitry limiting performance at high or low amplitudes (see Figure 2). A usable response of $< 100 \mu\text{V}$ and > 3 V extends the dynamic range with no external scaling, accommodating the most demanding low signal conditions.

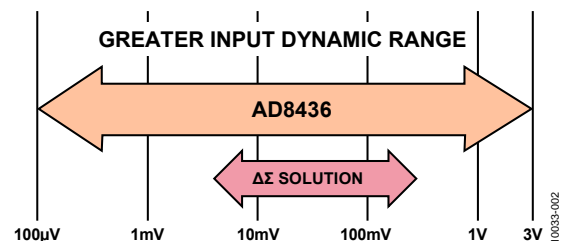

Figure 2. Usable Dynamic Range of the AD8436 vs. $\Delta\Sigma$

The AD8436 operates from single or dual supplies of ± 2.4 V (4.8 V) to ± 18 V (36 V). A and J grades are available in a compact 4 mm \times 4 mm, 20-lead chip-scale package. The operating temperature ranges are -40°C to 125°C and 0°C to 70°C .

TABLE OF CONTENTS

Features	1	Test Circuits.....	9
Functional Block Diagram	1	Theory of Operation	10
General Description	1	Overview	10
Revision History	2	Applications Information	12
Specifications.....	3	Using the AD8436.....	12
Absolute Maximum Ratings.....	4	AD8436 Evaluation Board.....	16
Thermal Resistance	4	Outline Dimensions	18
ESD Caution.....	4	Ordering Guide	18
Pin Configuration and Function Descriptions.....	5		
Typical Performance Characteristics	6		

REVISION HISTORY

7/11—Revision 0: Initial Version

SPECIFICATIONS

$e_{IN} = 300$ mV ac (rms), frequency = 1 kHz sinusoidal, ac-coupled, $\pm V_S = \pm 5$ V, $T_A = 25^\circ\text{C}$, $C_{AVG} = 10$ μF , unless otherwise specified.

Table 1.

Parameter	Test Conditions/Comments	Min	Typ	Max	Unit
RMS CORE					
Conversion Error	Default conditions	$\pm 10 - 0.5$	$\pm 0 \pm 0$	$\pm 10 + 0.5$	$\mu\text{V}/\%$ rdg
Vs. Temperature	$-40^\circ\text{C} < T < 125^\circ\text{C}$		0.006		$\%/^\circ\text{C}$
Vs. Rail Voltage	± 2.4 V to ± 18 V		± 0.013		$\pm\%/V$
Input Offset Voltage	DC-coupled	-500	0	+500	μV
Output Offset Voltage	Default conditions, ac-coupled input		0		V
Vs. Temperature	$-40^\circ\text{C} < T < 125^\circ\text{C}$		0.3		$\mu\text{V}/^\circ\text{C}$
DC Reversal Error	DC-coupled, $V_{IN} = \pm 300$ mV		± 0.5	± 2	%
Nonlinearity	$e_{IN} = 10$ mV to 300 mV ac (rms)		0.05		%
Crest Factor Error	Additional error				
$1 < CF < 10$	CCF = 0.1 μF	-0.5		+0.5	%
Peak Input Voltage		$-V_S - 0.7$		$+V_S + 0.7$	V
Input Resistance		7.92	8	8.08	k Ω
Frequency Response	$V_{IN} = 300$ mV rms				
1% Additional Error			65		kHz
3 dB Bandwidth			1		MHz
Settling Time					
0.1%	Rising/falling		148/341		ms
0.01%	Rising/falling		158/350		ms
Output Resistance		15.68	16	16.32	k Ω
Supply Current	No input		325	400	μA
INPUT BUFFER					
Signal Voltage Swing	$G = 1$				
Input	AC- or dc-coupled	$-V_S$		$+V_S$	V
Output	AC-coupled to Pin RMS	$-V_S + 0.2$		$+V_S - 0.2$	mV
Offset Voltage		-1	0	+1	mV
Input Bias Current				50	pA
Input Resistance			10^{12}		Ω
Frequency Response					
0.1 dB			950		kHz
3 dB Bandwidth			2.1		MHz
Supply Current		100	160	200	μA
Optional Gain Resistor		-9.9	+10	+10.1	k Ω
Gain Error	$G = \times 1$			0.05	%
OUTPUT BUFFER					
Offset Voltage	Connected to Pin OUT	-200	0	+200	μV
Input Current				3	nA
Output Voltage Swing		$-V_S + 0.0005$		$+V_S - 1$	V
Gain Error			0.003	0.01	%
Supply Current			40	70	μA
SUPPLY VOLTAGE					
Dual		± 2.4		± 18	V
Single		4.8		36	V

ABSOLUTE MAXIMUM RATINGS

Table 2.

Parameter	Rating
Supply Voltage	± 18 V
Internal Power Dissipation	18 mW
Input Voltage	$\pm V_S$
Output Short-Circuit Duration	Indefinite
Differential Input Voltage	$+V_S$ and $-V_S$
Temperature	
Operating Range	-40°C to $+125^\circ\text{C}$
Storage Range	-65°C to $+125^\circ\text{C}$
Lead Soldering (60 sec)	300°C
ESD Rating	2 kV

Stresses above those listed under Absolute Maximum Ratings may cause permanent damage to the device. This is a stress rating only; functional operation of the device at these or any other conditions above those indicated in the operational section of this specification is not implied. Exposure to absolute maximum rating conditions for extended periods may affect device reliability.

THERMAL RESISTANCE

θ_{JA} is specified for the worst-case conditions, that is, a device soldered in a circuit board for surface-mount packages.

Table 3. Thermal Resistance

Package Type	θ_{JA}	Unit
CP-20-10 LFCSP Without Thermal Pad	86	$^\circ\text{C}/\text{W}$
CP-20-10 LFCSP With Thermal Pad	48	$^\circ\text{C}/\text{W}$

ESD CAUTION



ESD (electrostatic discharge) sensitive device. Charged devices and circuit boards can discharge without detection. Although this product features patented or proprietary protection circuitry, damage may occur on devices subjected to high energy ESD. Therefore, proper ESD precautions should be taken to avoid performance degradation or loss of functionality.

PIN CONFIGURATION AND FUNCTION DESCRIPTIONS

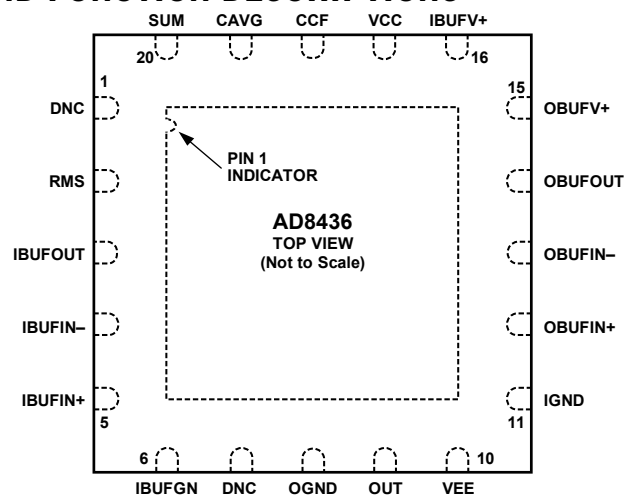

NOTES

1. DNC = DO NOT CONNECT. DO NOT CONNECT TO THIS PIN.
2. THE EXPOSED PAD SHOULD NOT BE CONNECTED.

Figure 3. Pin Configuration, Top View

Table 4. Pin Function Descriptions

Pin No.	Mnemonic	Description
1	DNC	Do Not Connect. Used for factory test.
2	RMS	AC Input to the RMS Core.
3	IBUFOUT	Output Connection for the FET Input Buffer Amplifier.
4	IBUFIN-	Inverting Input to the FET Input Buffer Amplifier.
5	IBUFIN+	Noninverting Input to the FET Input Buffer Amplifier.
6	IBUFGN	Optional 10 k Ω Precision Gain Resistor.
7	DNC	Do Not Connect. Used for factory test.
8	OGND	Internal 16 k Ω Current-to-Voltage Resistor. Connect to ground for voltage output at Pin 9; leave unconnected for current output at Pin 9.
9	OUT	Voltage or Current Output of the RMS Core.
10	VEE	Negative Supply Rail.
11	IGND	Half Supply Node. Leave open for single-supply operation.
12	OBUFIN+	Noninverting Input of the Optional Precision Output Buffer. OBUFIN+ is typically connected to OUT.
13	OBUFIN-	Inverting Input of the Optional Precision Output Buffer. OBUFIN- is typically connected to OBUFOUT.
14	OBUFOUT	Low Impedance Output for ADC or Other Loads.
15	OBUFV+	Power Pin for the Output Buffer.
16	IBUFV+	Power Pin for the Input Buffer.
17	VCC	Positive Supply Rail for the RMS Core.
18	CCF	Connection for Crest Factor Capacitor.
19	CAVG	Connection for Averaging Capacitor.
20	SUM	Summing Amplifier Input Node. An external resistor can be connected for custom scaling.
EP	DNC	Exposed Pad. The exposed pad should not be connected.

TYPICAL PERFORMANCE CHARACTERISTICS

$T_A = 25^\circ\text{C}$, $\pm V_S = \pm 5\text{ V}$, $C_{AVG} = 10\ \mu\text{F}$, 1 kHz sine wave, unless otherwise indicated.

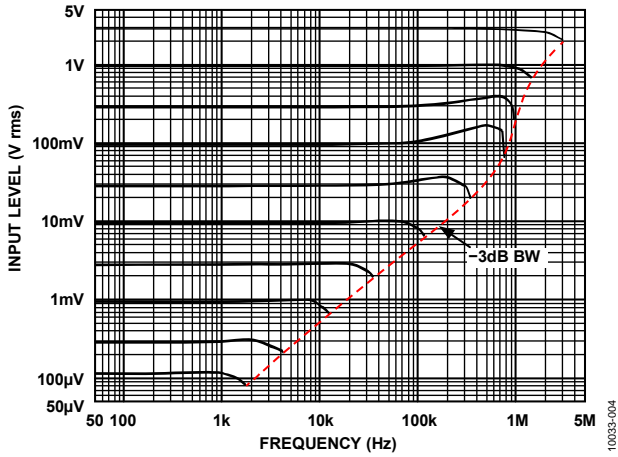

Figure 4. RMS Core Frequency Response (See Figure 20)

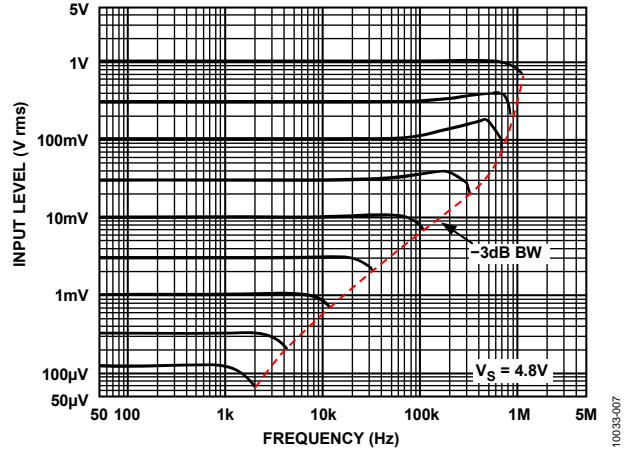

Figure 7. RMS Core Frequency Response with $V_S = +4.8\text{ V}$ (See Figure 21)

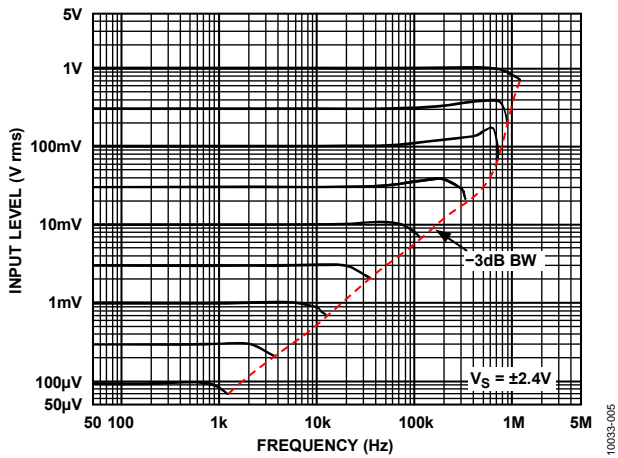

Figure 5. RMS Core Frequency Response with $V_S = \pm 2.4\text{ V}$ (See Figure 20)

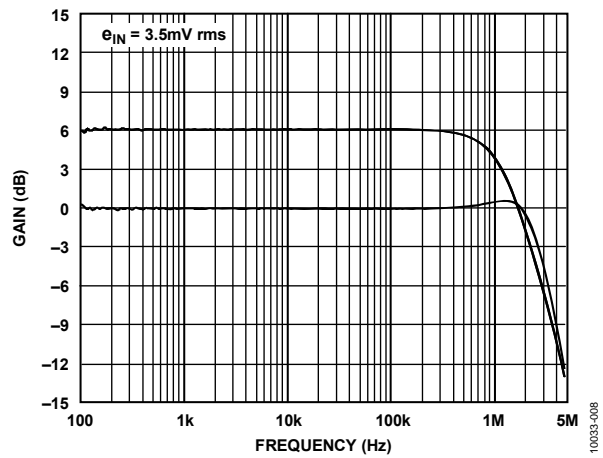

Figure 8. Input Buffer, Small Signal Bandwidth at 0 dB and 6 dB Gain

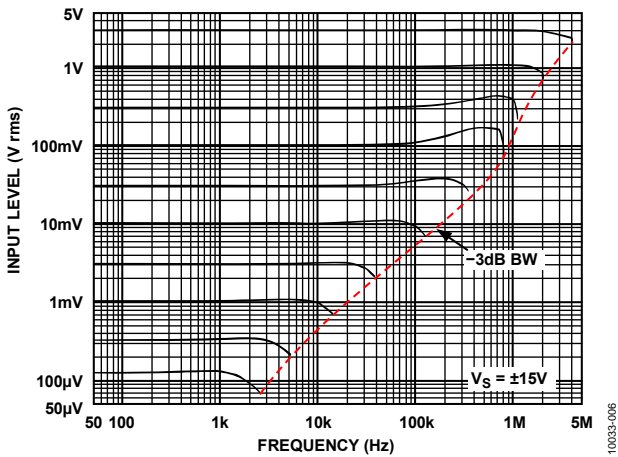

Figure 6. RMS Core Frequency Response with $V_S = \pm 15\text{ V}$ (See Figure 20)

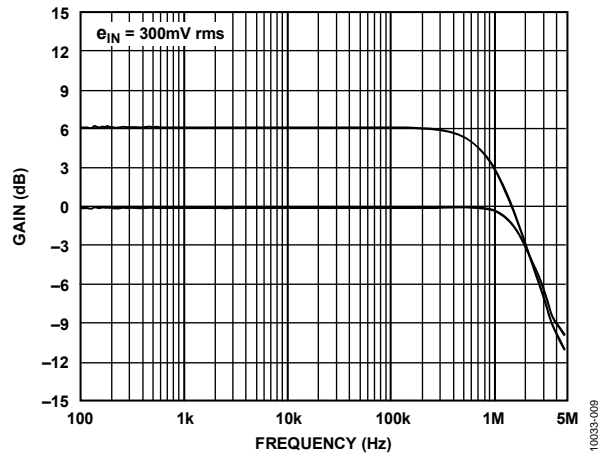

Figure 9. Input Buffer, Large Signal Bandwidth at 0 dB and 6 dB Gain

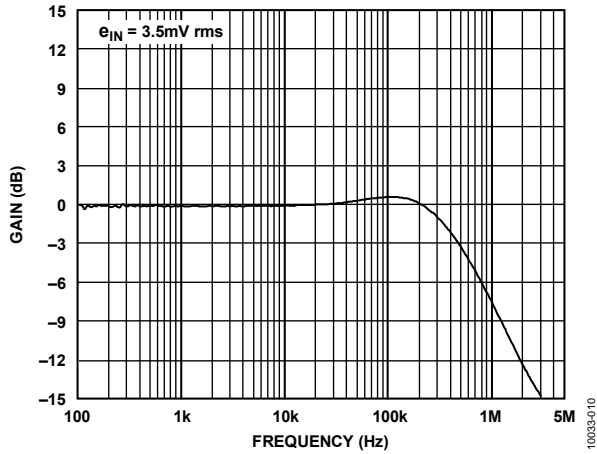

Figure 10. Output Buffer, Small Signal Bandwidth

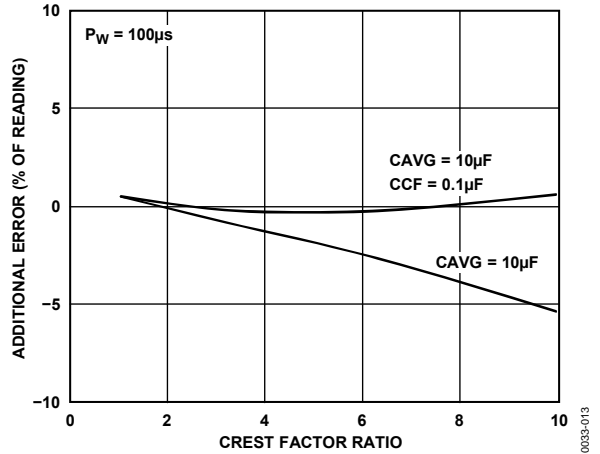

Figure 13. Crest Factor Error vs. Crest Factor for CAVG and CAVG and CCF Capacitor Combinations

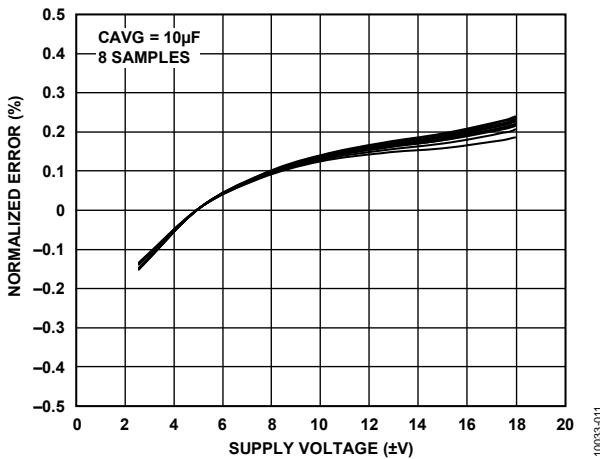

Figure 11. Additional Error vs. Supply Voltage

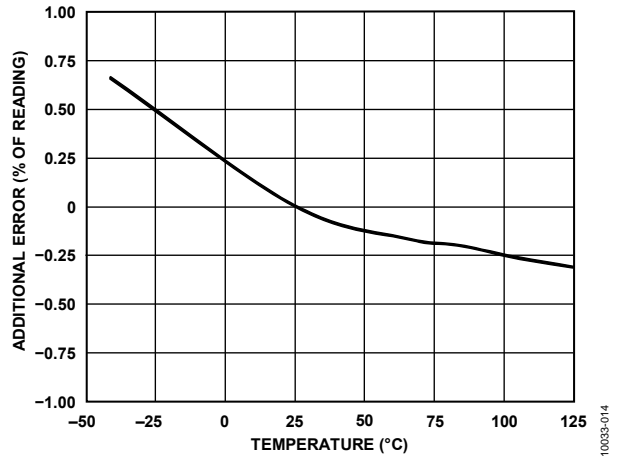

Figure 14. Additional Conversion Error vs. Temperature

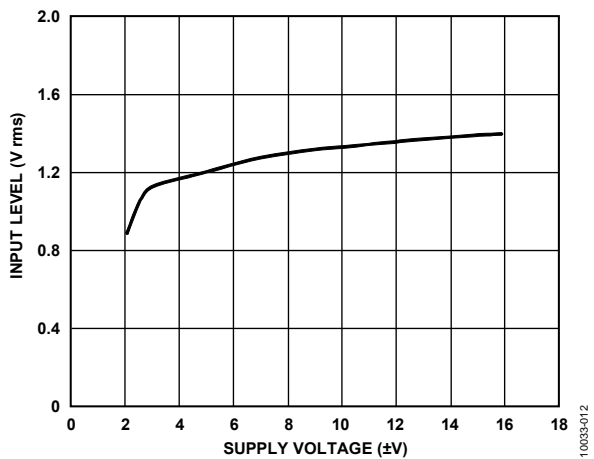

Figure 12. Core Input Voltage for 1% Error vs. Supply Voltage

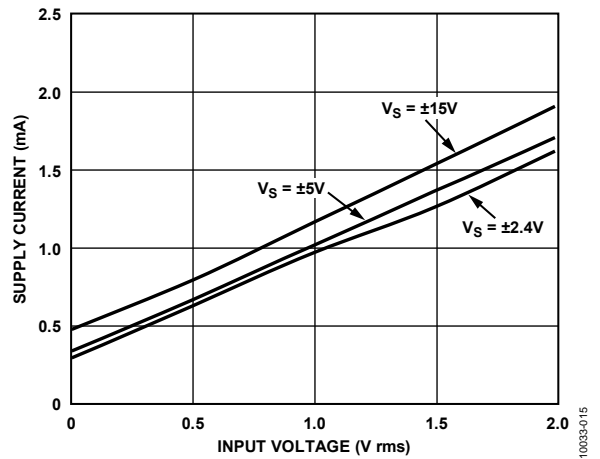

Figure 15. RMS Core Supply Current vs. Input for $V_S = \pm 2.4\text{V}$, $\pm 5\text{V}$, and $\pm 15\text{V}$

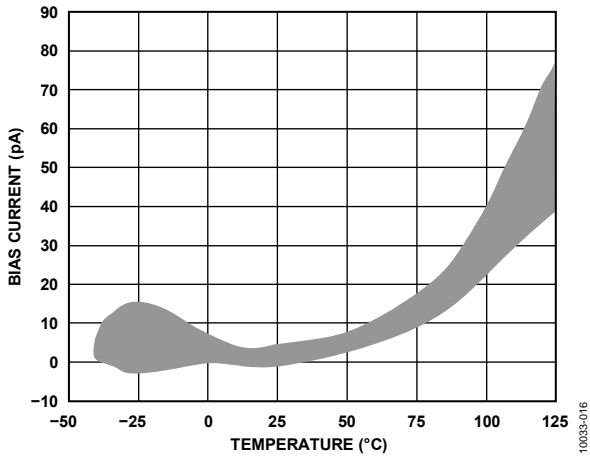

Figure 16. FET Input Buffer Bias Current vs. Temperature

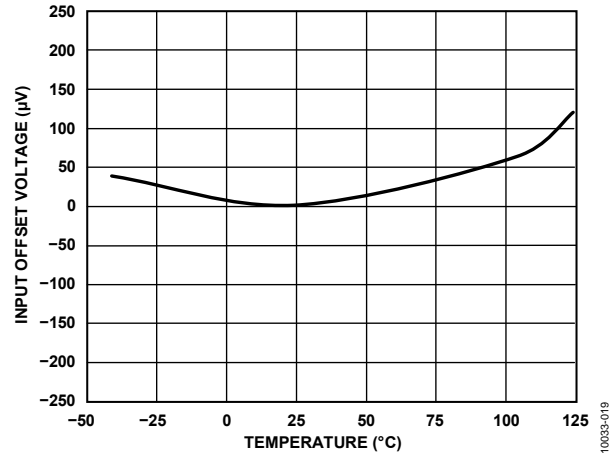

Figure 18. Output Buffer V_{OS} vs. Temperature

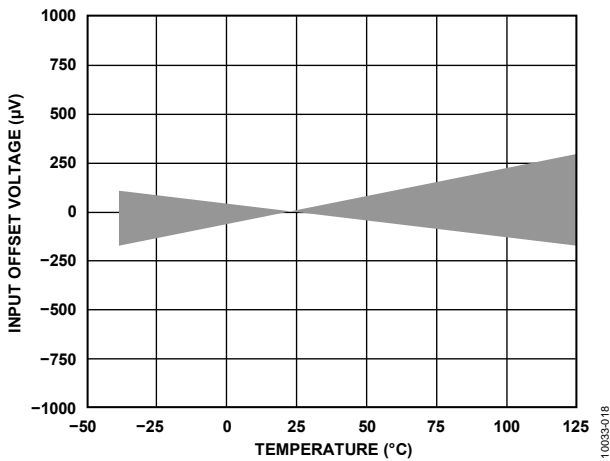

Figure 17. Input Offset Voltage of FET Buffer vs. Temperature

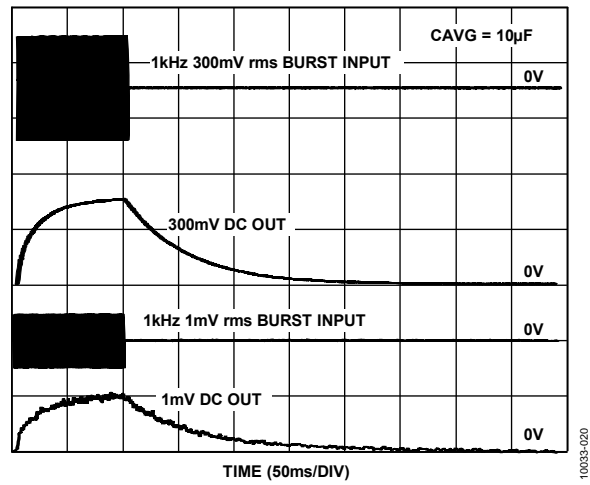

Figure 19. Transition Times with 1 kHz Burst at Two Input Levels (See Theory of Operation Section)

TEST CIRCUITS

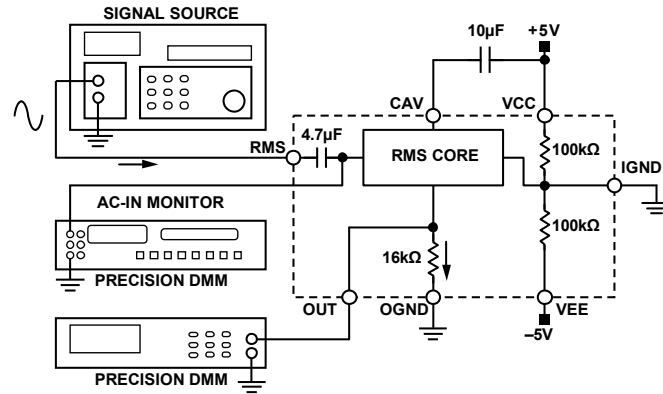

Figure 20. Core Response Test Circuit Using Dual Supplies

10033-021

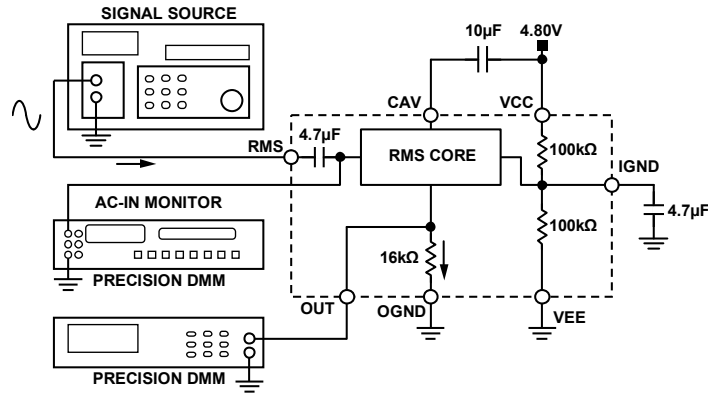

Figure 21. Core Response Test Circuit Using a Single Supply

10033-022

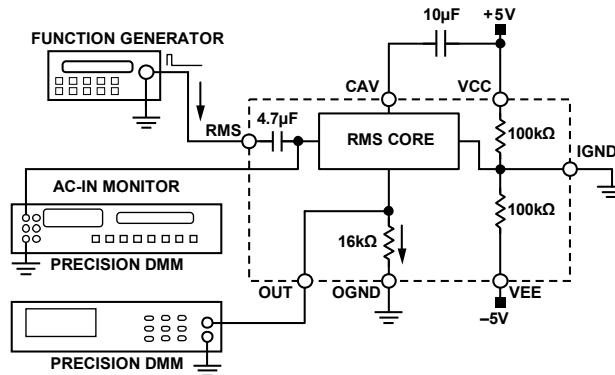

Figure 22. Crest Factor Test Circuit

10033-023

THEORY OF OPERATION

OVERVIEW

The AD8436 is an implicit function rms-to-dc converter that renders a dc voltage dependent on the rms (heating value) of an ac voltage. In addition to the basic converter, this highly integrated functional circuit block includes two fully independent, optional amplifiers, a standalone FET input buffer amplifier and a precision dc output buffer amplifier (see Figure 1). The rms core includes a precision current responding full-wave rectifier and a log-antilog transistor array for current squaring and square rooting to implement the classic expression for rms (see Equation 1). For basic applications, the converter requires only an external capacitor, for averaging (see Figure 30). The optional on-board amplifiers offer utility and flexibility in a variety of applications without incurring additional circuit board footprint. For lowest power, the amplifier supply pins are left unconnected.

Why RMS?

The rms value of an ac voltage waveform is equal to the dc voltage providing the same heating power to a load. A common measurement technique for ac waveforms is to rectify the signal in a straightforward way using a diode array of some sort, resulting in the average value. The average value of various waveforms (sine, square, and triangular, for example) varies widely; true rms is the only metric that achieves equivalency for all ac waveforms. See Table 5 for non-rms-responding circuit errors.

The acronym “rms” means *root-mean-square* and reads as follows: “the square root of the average of the sum of the squares” of the peak values of any waveform. RMS is shown in the following equation:

$$e_{rms} = \sqrt{\frac{1}{n} \sum_{i=1}^n x_i^2} \tag{1}$$

For additional information, select Section I of the 2nd edition of the *Analog Devices RMS-to-DC Applications Guide*.

RMS Core

The core consists of a voltage-to-current converter (precision resistor), absolute value, and translinear sections. The translinear section exploits the properties of the bipolar transistor junctions for squaring and root extraction (see Figure 23). The external capacitor (CAVG) provides for averaging the product. Figure 19 shows that there is no effect of signal input on the transition times, as seen in the dc output. Although the rms core responds to input voltages, the conversion process is current sensitive. If the rms input is ac-coupled, as recommended, there is no output offset voltage, as reflected in Table 1. If the rms input is dc-coupled, the input offset voltage is reflected in the output and can be calibrated as with any fixed error.

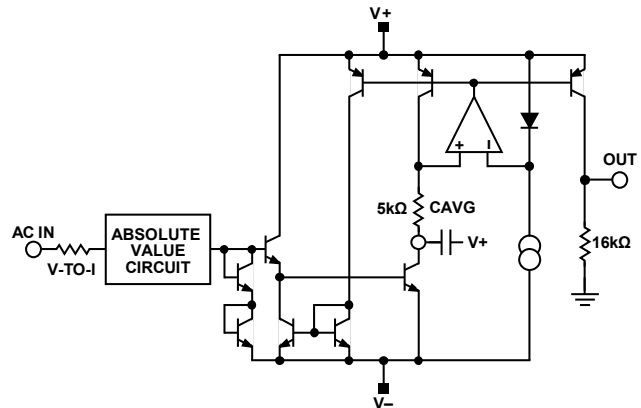

Figure 23. RMS Core Block Diagram

Table 5. General AC Parameters

Waveform Type (1 V p-p)	Crest Factor	RMS Value	Reading of an Average Value Circuit Calibrated to an RMS Sine Wave	Error (%)
Sine	1.414	0.707	0.707	0
Square	1.00	1.00	1.11	11.0
Triangle	1.73	0.577	0.555	-3.8
Noise	3	0.333	0.295	
Rectangular	2	0.5	0.278	-11.4
Pulse	10	0.1	0.011	-44
SCR				-89
DC = 50%	2	0.495	0.354	-28
DC = 25%	4.7	0.212	0.150	-30

The 16 k Ω resistor in the output converts the output current to a dc voltage that can be connected to the output buffer or to the circuit that follows. The output appears as a voltage source in series with 16 k Ω . If a current output is desired, the resistor connection to ground is left open and the output current is applied to a subsequent circuit, such as the summing node of a current summing amplifier. Thus, the core has both current and voltage outputs, depending on the configuration. For a voltage output with 0 Ω source impedance, use the output buffer. The offset voltage of the buffer is 25 μ V or 50 μ V, depending on the grade.

FET Input Buffer

Referring to Figure 1, the input resistance of the AD8436 is 8 k Ω , and a voltage source input is preferred. The optional input buffer is a wideband JFET input amplifier that minimally loads non-0 Ω sources, such as a tapped resistor attenuator or voltage sensor. Although the input buffer consumes only 150 μ A, the supply is pinned out and left unconnected to reduce power where needed.

Optional matched 10 k Ω input and feedback resistors are provided on chip. Consult the Applications Information section to learn how these resistors can be used. The 3 dB bandwidth of the input buffer is 2.7 MHz at 10 mV rms input and approximately 1.5 MHz at 1 V rms. The amplifier gain and bandwidth are sufficient for applications requiring modest gain or response enhancement to a few hundred kilohertz (kHz), if desired. Configurations of the input buffer are discussed in the Applications Information section.

Precision Output Buffer

The precision output buffer is a bipolar input amplifier, laser trimmed to cancel input offset voltage errors. As with the input buffer, the supply current is very low (<50 μ A, typically), and the power can be disconnected for power savings if the buffer is not needed. Be sure that the noninverting input is also disconnected from the core output (OUT) if the buffer supply pin is disconnected. Although the input current of the buffer is very low, a laser-trimmed 16 k Ω resistor, connected in series with the inverting input, offsets any self-bias offset voltage.

The output buffer can be configured as a single or two-pole low-pass filter using circuits shown in the Applications Information section. Residual output ripple is reduced, without affecting the converted dc output. As the response approaches the low frequency end of the bandwidth, the ripple rises, dependent on the value of the averaging capacitor. Figure 26 shows the effects of four combinations of averaging and filter capacitors. Although the filter capacitor reduces the ripple for any given frequency, the dc error is unaffected. Of course, a larger value averaging capacitor can be selected, at a larger cost. The advantage of using a low-pass filter is that a small value of filter capacitor, in conjunction with the 16 k Ω output resistor, reduces ripple and permits a smaller averaging capacitor, effecting a cost savings. The recommended capacitor values for operation to 40 Hz are 10 μ F for averaging and 3.3 μ F for filter.

Dynamic Range

The AD8436 is a translinear rms-to-dc converter with exceptional dynamic range. Although accuracy varies slightly more at the extreme input values, the device still converts with no spurious noise or dropout. Figure 24 is a plot of the rms/dc transfer function near zero voltage. Unlike processor or other solutions, residual errors at very low input levels can be disregarded for most applications.

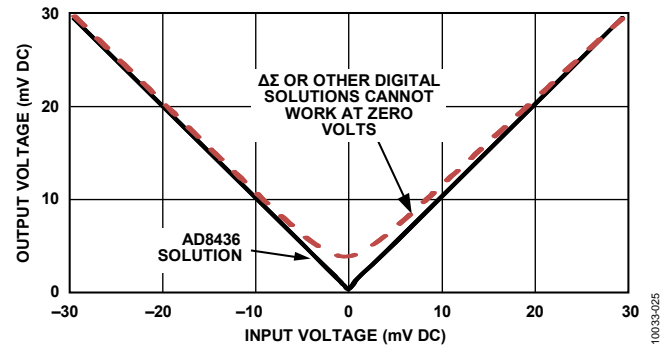

Figure 24. DC Transfer Function near Zero

APPLICATIONS INFORMATION USING THE AD8436

This section describes the power supply and feature options, as well as the function and selection of averaging and filter capacitor values. Averaging and filtering options are shown graphically and apply to all circuit configurations.

Averaging Capacitor Considerations—RMS Accuracy

Typical AD8436 applications require only a single external capacitor (CAVG) connected to the CAVG pin (see Figure 30). The function of the averaging capacitor is to compute the mean (that is, average value) of the sum of the squares. Averaging (that is, integration) follows the absolute value circuit, where the polarity of negative input current components is reversed (rectified) prior to squaring. The mean value is the average value of the squared input voltage over several input waveform periods. The rms error is directly affected by the number of periods averaged, as is the resultant peak-to-peak ripple.

The result of the conversion process is a dc component and a ripple component whose frequency is twice that of the input. The rms conversion accuracy depends on the value of CAVG, so the value selected need only be large enough to average enough periods at the lowest frequency of interest to yield the required rms accuracy. Figure 27 is a plot of rms error vs. frequency for various averaging capacitor values. For Figure 27, the additional error was 0.001% at 40 Hz using a 10 μF metallized polyester capacitor. Larger values yield diminished returns because the settling time increases with negligible improvement in rms accuracy.

To use Figure 27, determine the minimum operating frequency and accuracy of the application and then find the suggested capacitor value on the chart. For example, for -0.5% rms at 100 Hz, the capacitor value is 1 μF .

Post Conversion Ripple Reduction Filter

Input rectification included in the AD8436 introduces a residual ripple component that is dependent on the value of CAVG and twice the input signal frequency. For sampling applications such as a high resolution ADC, the ripple component may cause one or more LSBs to cycle, and low value display numerals to flash.

Ripple is reduced by increasing the value of the averaging capacitor, or by postconversion filtering. Ripple reduction following conversion is far more efficient because the ripple average value has been converted to its rms value. Capacitor values for post-conversion filtering are significantly less than the equivalent averaging capacitor value for the same level of ripple reduction. This approach requires only a single capacitor connected to the OUT pin (see Figure 25). The capacitor value correlates to the simple frequency relation of $\frac{1}{2} \pi R\text{-}C$, where R is fixed at 16 k Ω .

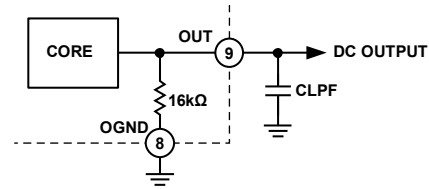

Figure 25. Simple One-Pole Post Conversion Filter

As seen in Figure 26, CAVG alone determines the rms error, and CLPF serves purely to reduce ripple. Figure 26 shows a constant rms error for CLPF values of 0.33 μF and 3.3 μF ; only the ripple is affected.

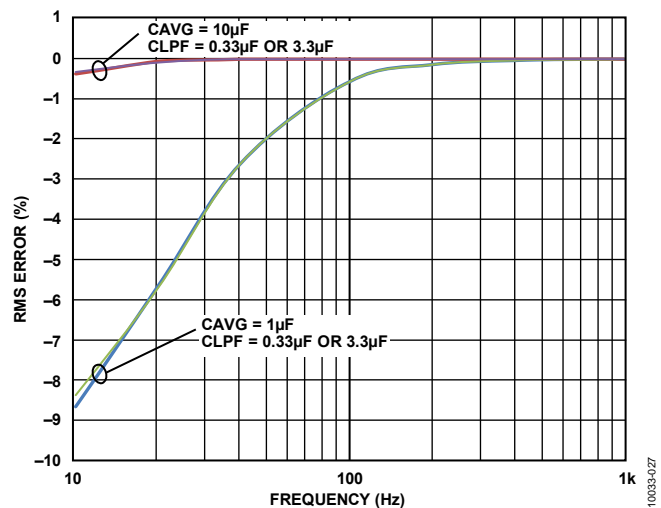

Figure 26. RMS Error vs. Frequency for Two Values of CAVG and CLPF (Compare the effects of CAVG and CLPF, and note that CLPF does not affect rms error result.)

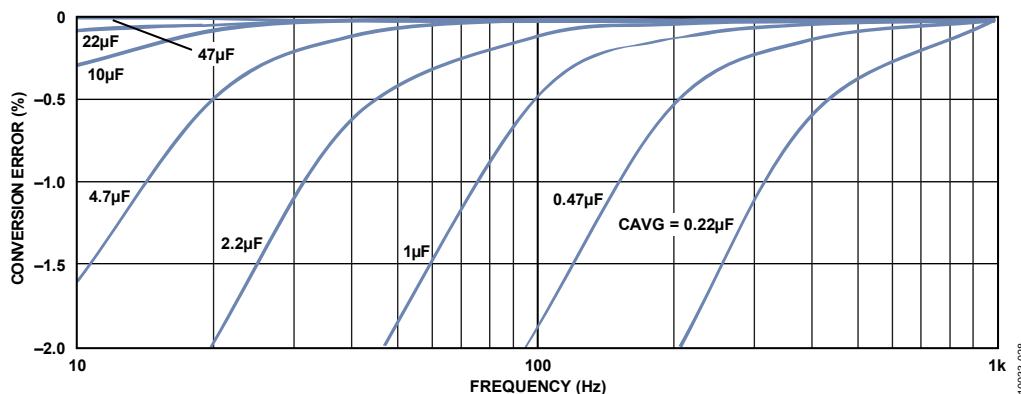

Figure 27. Conversion Error vs. Frequency for Various Values of CAVG

For simplicity, Figure 28 shows ripple vs. frequency for four combinations of CAVG and CLPF

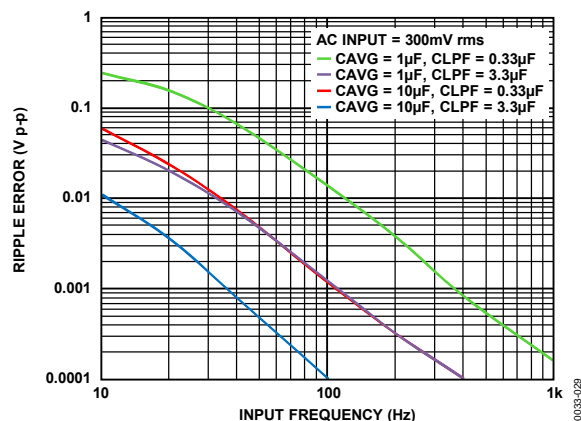

Figure 28. Residual Ripple Voltage for Various Filter Configurations

Figure 29 shows the effects of averaging and post-rms filter capacitors on transition and settling times using a 10-cycle, 50 Hz, 1 second period burst signal input to demonstrate time-domain behavior. In this instance, the averaging capacitor value was $10\ \mu\text{F}$, yielding a ripple value of 6 mV rms. A postconversion capacitor (CLPF) of $.068\ \mu\text{F}$ reduced the ripple to 1 mV rms. An averaging capacitor value of $82\ \mu\text{F}$ reduced the ripple to 1 mV but extended the transition time (and cost) significantly.

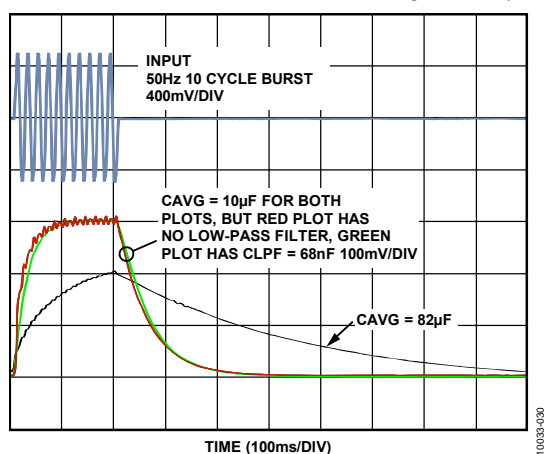

Figure 29. Effects of Various Filter Options on Transition Times

Capacitor Construction

Although tolerant of most capacitor styles, rms conversion accuracy can be affected by the type of capacitor that is selected. Capacitors with low dc leakage yield best all around performance, and many sources are available. Metalized polyester or similar film styles are best, as long as the temperature range is appropriate.

For practical applications such as the rms-to-dc function in DMMs or power monitoring circuits, surface mount tantalums are the best over-all choice.

Basic Core Connections

Many applications require only a single external capacitor for averaging. A $10\ \mu\text{F}$ capacitor is more than adequate for acceptable rms errors at line frequencies and below.

The signal source sees the input $8\ \text{k}\Omega$ voltage-to-current conversion resistor at Pin 2 (RMS); thus, the ideal source impedance is a voltage source ($0\ \Omega$ source impedance). If a non-zero signal source impedance cannot be avoided, be sure to account for any series connected voltage drop.

An input coupling capacitor must be used to realize the near-zero output offset voltage feature of the AD8436. Select a coupling capacitor value that is appropriate for the lowest expected operating frequency of interest. As a rule of thumb, the input coupling capacitor can be the same as or half the value of the averaging capacitor because the time constants are similar. For a $10\ \mu\text{F}$ averaging capacitor, a $4.7\ \mu\text{F}$ or $10\ \mu\text{F}$ tantalum capacitor is a good choice (see Figure 30).

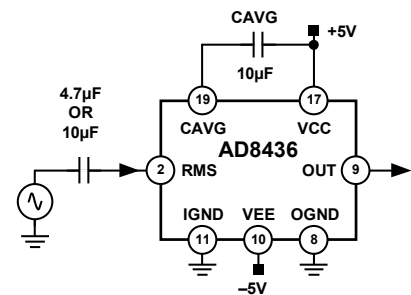

Figure 30. Basic Applications Circuit

Using a Capacitor for High Crest Factor Applications

The AD8436 contains a unique crest factor feature. Crest factor is often overlooked when considering the requirements of rms-to-dc converters, but it is very important when working with signals with spikes or high peaks. The crest factor is defined as the ratio of peak voltage to rms. See Table 5 for crest factors for some common waveforms.

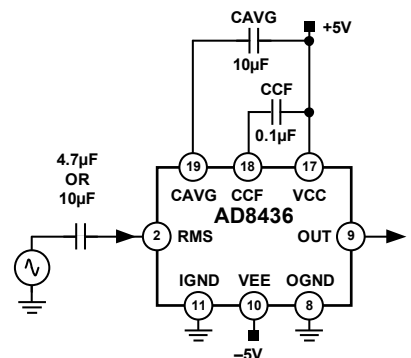

Figure 31. Connection for Additional Crest Factor Performance

Crest factor performance is mostly applicable for unexpected waveforms such as switching transients in switchmode power supplies. In such applications, most of the energy is in these peaks and can be destructive to the circuitry involved, although the average ac value can be quite low.

Figure 13 shows the effects of an additional crest factor capacitor of $0.1\ \mu\text{F}$ and an averaging capacitor of $10\ \mu\text{F}$. The larger capacitor serves to average the energy over long spaces between pulses, while the CCF capacitor charges and holds the energy within the relatively narrow pulse.

Using the FET Input Buffer

The on-chip FET input buffer is an uncommitted FET input op amp used for driving the 8 kΩ I-to-V input resistor of the rms core. Pin 3, Pin 4, and Pin 5 are the I/O, Pin 6 is an optional connection for gain in the input buffer, and Pin 16 connects power to the buffer (see Figure 3 and Table 4 for location and description). Connecting Pin 16 to the positive rail is the only power connection required because the negative rail is internally connected. Because the input stage is a FET and the input impedance must be very high to prevent loading of the source, a large value (10 MΩ) resistor must be connected from midsupply at Pin 11 (IGND) to Pin 5 (IBUFIN+) to prevent the input gate from floating high.

For unity gain, connect Pin 3 (IBUFOUT) to Pin 4 (IBUFIN-). For a gain of 2×, connect Pin 6 (IBUFGN) to ground. See Figure 8 and Figure 9 for large and small signal responses at the two built-in gain options.

The offset voltage of the input buffer is ≤500 μV, depending on grade. A capacitor connected between the Buffer Output Pin 3 (IBUFOUT) and Pin 2 (RMS) is recommended so that the input buffer offset voltage does not contribute to the overall error. Select the capacitor value for least minimum error at the lowest operating frequency. Figure 32 is a schematic showing internal components and pin connections.

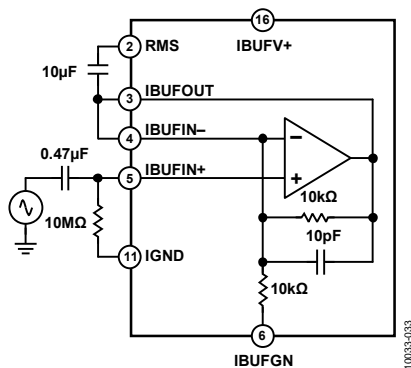

Figure 32. Connecting the FET Input Buffer

Capacitor coupling at the input and output of the FET buffer is recommended to avoid transferring the buffer offset voltage to the output. Although the FET input impedance is extremely high, the 10 MΩ centering resistor connected to IGND must be taken into account when selecting an input capacitor value. This is simply an impedance calculation using the lowest desired frequency, and finding a capacitor value based on the least attenuation desired.

Because the 10 kΩ resistors are closely matched and trimmed to a high tolerance, the input buffer gain can be increased to several hundred with an external resistor connected to Pin 4 (IBUFIN-).

The bandwidth diminishes at the typical rate of a decade per 20 dB of gain, and the output voltage range is constrained. The small signal response, as shown in Figure 8, serves as a guide. As an example, suppose one wanted to detect small input signals at power line frequencies? An external 10 Ω resistor connected from Pin 4 to ground sets the gain to 101 and the 3 dB bandwidth to ~30 kHz, which is more than adequate for amplifying power line frequencies.

Using the Output Buffer

The AD8436 output is a precision op amp that is optimized for dc operation. Figure 33 shows a block diagram of the basic amplifier and I/O pins. The amplifier is intended for noninverting operation only; note that the 16 kΩ resistor, in series with the inverting input of the amplifier, is used to balance the bias current of the noninverting amplifier.

As with the input FET buffer, the amplifier positive supply is pinned out separately for power sensitive applications. In normal circumstances, the buffers are connected to the same supply as the core. Figure 34 shows the signal connections to the output buffer. Note that the input offset voltage contribution by the bias currents are balanced by equal value series resistors, resulting in near zero offset voltage.

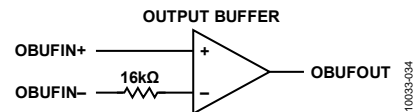

Figure 33. Output Buffer Block Diagram

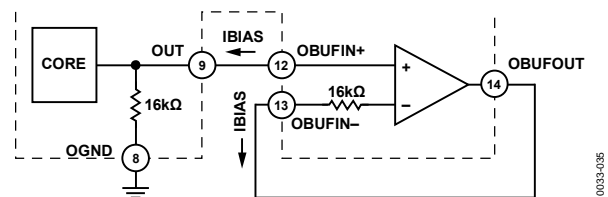

Figure 34. Basic Output Buffer Connections

For applications requiring ripple suppression in addition to the single-pole output filter described previously, the output buffer is configurable as a two-pole Sallen-Key filter using two external resistors and two capacitors. At just over 100 kHz, the amplifier has enough bandwidth to function as an active filter for low frequencies such as power line ripple. For a modest savings in cost and complexity, the external 16 kΩ feedback resistor can be omitted, resulting in slightly higher V_{OS} (80 μV).

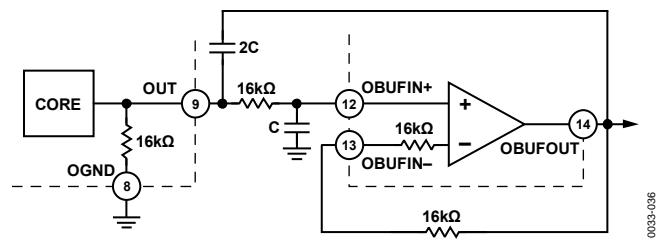

Figure 35. Output Buffer Amplifier Configured as a Two-Pole, Sallen-Key Low-Pass Filter

Configure the output buffer as shown in Figure 36 to invert the dc output.

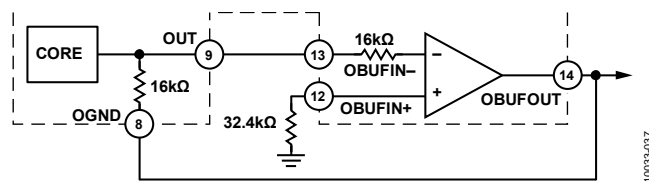

Figure 36. Inverting Output Configuration

Current Output Option

If a current output is required, connect the current output, OUT (Pin 9), to the destination load. To maximize precision, provide a means for external calibration to replace the internal trimmed resistor, which is bypassed. This configuration is useful for convenient summing of the AD8436 result with another voltage, or for polarity inversion.

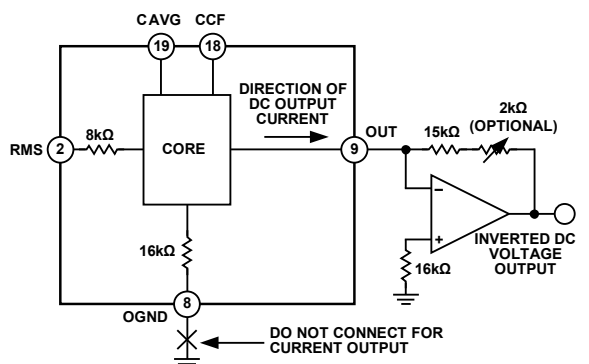

Figure 37. Connections for Current Output Showing Voltage Inversion

Single Supply

Connections for single supply operation are shown in Figure 38 and are similar to those for dual power supply when the device is ac-coupled. The analog inputs are all biased to half the supply voltage, but the output remains referred to ground because the output of the AD8436 is a current source. An additional bypass connection is required at Pin 11 (IGND) to suppress ambient noise.

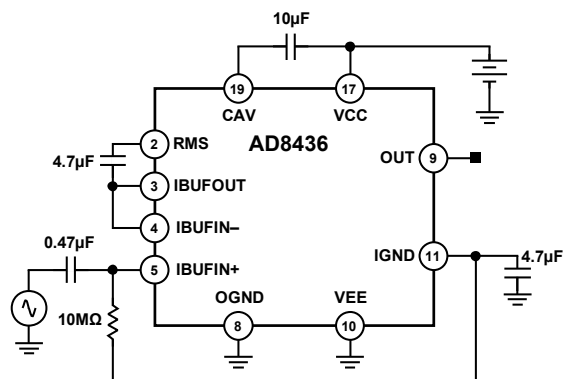

Figure 38. Connections for Single Supply Operation

Recommended Application

Figure 39 shows a circuit for a typical application for frequencies as low as power line, and above. The recommended averaging, crest factor and LPF capacitor values are 10 μF, 0.1 μF and 3.3 μF. Refer to the Using the Output Buffer section if additional low-pass filtering is required.

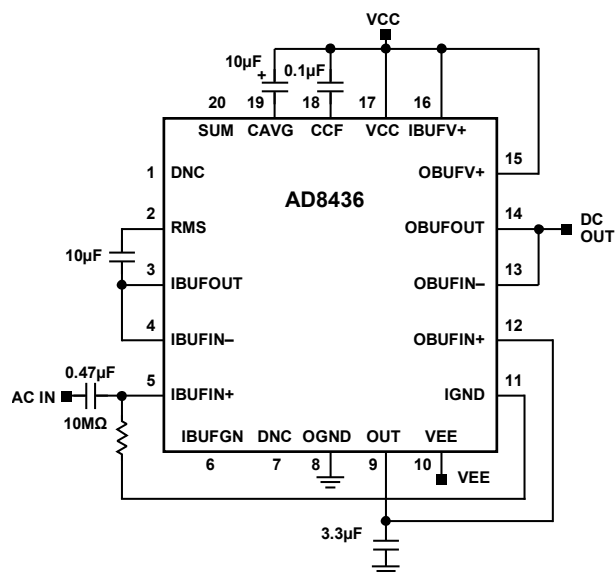

Figure 39. Typical Application Circuit

AD8436

AD8436 EVALUATION BOARD

The AD8436-EVALZ provides a platform to evaluate AD8436 performance. The board is fully assembled, tested and ready to use after the power and signal sources are connected. Figure 45 is a photograph of the board. Signal connections are located on the primary and secondary sides, with power and ground on the inner layers. Figure 40, Figure 41, Figure 42, Figure 43, and Figure 44 illustrate the various design details of the board, including a basic layout and copper patterns. These figures are useful for reference for application designs.

A Word About Using the AD8436 Evaluation Board

The AD8436-EVALZ offers many options, without sacrificing simplicity. The board is tested and shipped with a 10 μF averaging capacitor (CAVG), 3.3 μF low-pass filter capacitor (C8) and a 0.1 μF (COPT) capacitor to optimize crest factor performance. To evaluate minimum cost applications, remove C8 and COPT. The functions of the five switches are listed in Table 6.

Table 6.

Switch	Function
CORE_BUFFER	Selects core or input for the input signal
INCOUP	Selects ac or dc coupling to the core
SDCOUT	Selects the output buffer or the core output at the DCOUT BNC.
IBUF_VCC	Enable or disables the input buffer
OBUF_VCC	Enable or disables the output buffer

All the I/Os are provided with test points for easy monitoring with test equipment. The input buffer gain default is unity; for 2 \times gain, install a 0603 0 Ω resistor at Position R5. For higher IBUF gains, remove the 0 Ω resistor at Position RFBH (there is an internal 10 k Ω resistor from the OBUF_OUT to IBUFIN-) and install a smaller value resistor in Position RFBF. A 100 Ω resistor establishes a gain of 100 \times .

Single supply operation requires removal of Resistor R6 and installing a 0.1 μF capacitor in the same position for noise decoupling.

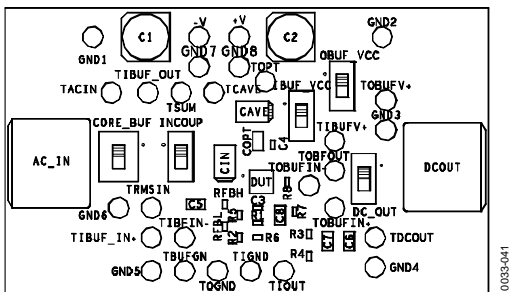

Figure 40. Assembly of the AD8436-EVALZ

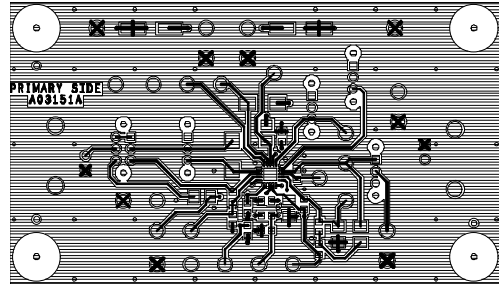

Figure 41. AD8436-EVALZ Primary Side Copper

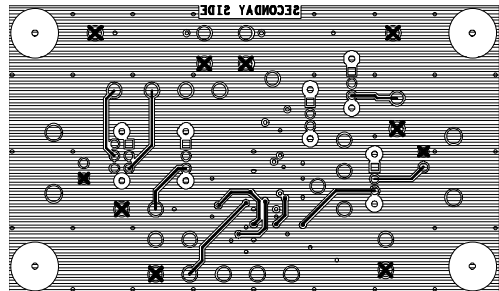

Figure 42. AD8436-EVALZ Secondary Side Copper

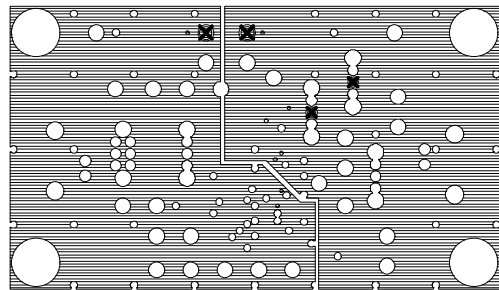

Figure 43. AD8436-EVALZ Power Plane

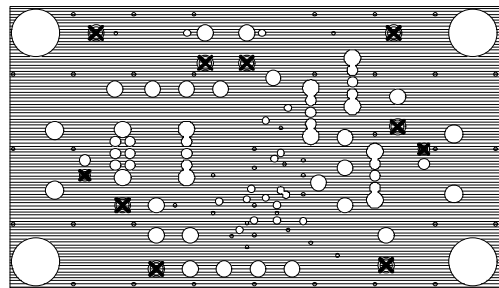

Figure 44. AD8436-EVALZ Ground Plane

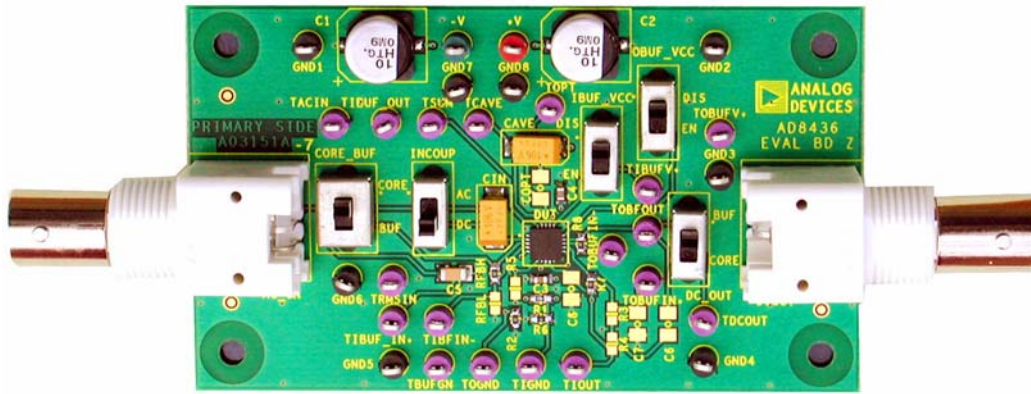

Figure 45. Photograph of the AD8436-EVALZ

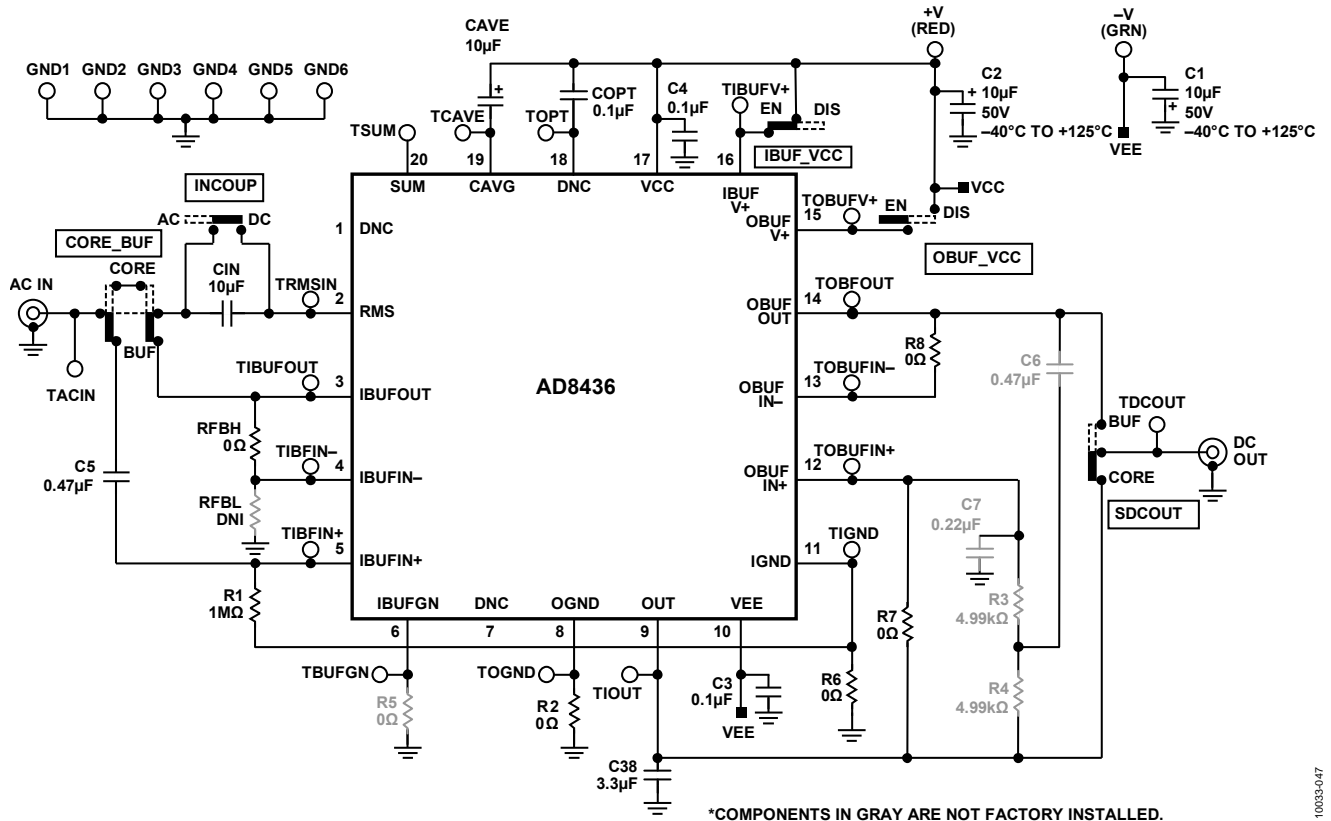
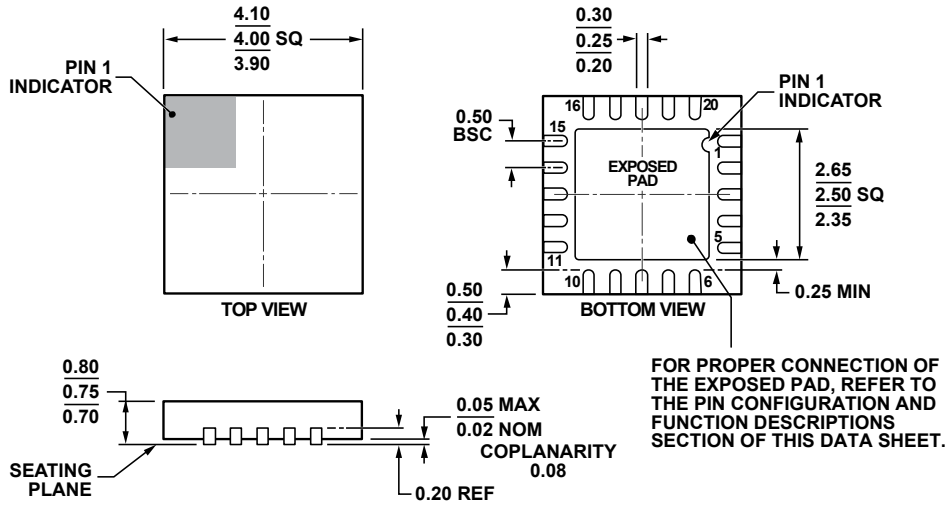

Figure 46. Evaluation Board Schematic

OUTLINE DIMENSIONS



COMPLIANT TO JEDEC STANDARDS MO-220-WGGD.

Figure 47. 20-Lead Lead Frame Chip Scale Package [LFCSP_WQ] (CP-20-10)

Dimensions shown in inches

061609-B

ORDERING GUIDE

Model ¹	Temperature Range	Package Description	Package Option
AD8436ACPZ-R7	-40°C to +125°C	20-Lead Lead Frame Chip Scale [LFCSP_WQ]	CP-20-10
AD8436ACPZ-RL	-40°C to +125°C	20-Lead Lead Frame Chip Scale [LFCSP_WQ]	CP-20-10
AD8436ACPZ-WP	-40°C to +125°C	20-Lead Lead Frame Chip Scale [LFCSP_WQ]	CP-20-10
AD8436JCPZ-R7	0°C to +70°C	20-Lead Lead Frame Chip Scale [LFCSP_WQ]	CP-20-10
AD8436JCPZ-RL	0°C to +70°C	20-Lead Lead Frame Chip Scale [LFCSP_WQ]	CP-20-10
AD8436JCPZ-WP	0°C to +70°C	20-Lead Lead Frame Chip Scale [LFCSP_WQ]	CP-20-10
AD8436-EVALZ		Evaluation Board	

¹ Z = RoHS Compliant Part.

NOTES

NOTES