

- Capacitance to Digital Converter (CDC) IC
- Direct-to-digital conversion, 16 bits
- Log response: Wide dynamic range
- Outputs raw data to a host device
- Single wire UART interface
- Master or Slave mode SPI interface
- Programmable clock speed
- Turns objects into intrinsic touch sensors
- One external sample capacitor to control gain
- Multiple QT300's possible on one SPI bus

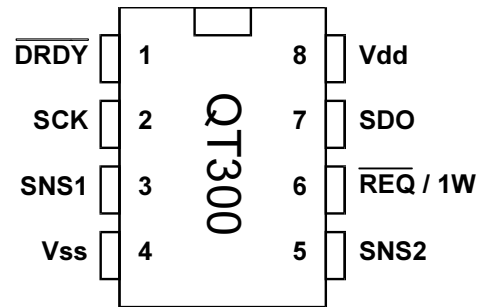

### APPLICATIONS

- Fluid level sensors
- Prox sensors
- Moisture detection
- Position sensing
- Transducer driver
- Material sensors

The QT300 charge-transfer ("QT") IC is a self-contained Capacitance-to-Digital-Converter (CDC) capable of detecting femtofarad level changes in capacitance. While designed primarily for instrumentation applications, it can be used also for touch control applications where signal processing is best handled by a host MCU.

Primary applications include fluid level sensors, distance sensors, transducer 'amplifiers' for pressure and humidity sensing functions, material detectors, and other uses requiring quantified capacitance data.

Unlike other Quantum products, the QT300 does not process its acquired data. Its only result is raw, unprocessed binary data which can be transmitted to a host via either a bidirectional SPI interface or a simple polled single wire UART type interface. This allows the designer to treat the device as a capacitance-to-digital-converter (CDC) for measurement applications. It is ideal for situations where there are unique signal processing requirements.

The device requires only a single sampling capacitor to function. The value of this capacitor controls the gain of the sensor, and it can be adjusted over 2½ decades of range from 1nF to 500nF. No external switches, opamps, or other components are required.

The device operates on demand, and can be synchronized to allow several QT300's to operate near each other without cross-interference.

### AVAILABLE OPTIONS

T <sub>A</sub>	SOIC	8-PIN DIP
0°C to +70°C	-	QT300-D
-40°C to +85°C	QT300-IS	-

Table 1-1 SPI Mode Pin Description		
Pin	Name	Function
1	/DRDY	Data Ready
2	SCK	Serial data clock
3	SNS1	Sense 1 line
4	VSS	Negative supply (ground)
5	SNS2	Sense 2 line
6	/REQ	Request input
7	SDO	Serial data out
8	VDD	Positive supply

Table 1-2 1W UART Mode Pin Description		
Pin	Name	Function
1	-	Connect to Vdd or Vss
2	-	Connect to Vdd or Vss
3	SNS1	Sense 1 line
4	VSS	Negative supply (ground)
5	SNS2	Sense 2 line
6	1W	1W UART Line
7	-	Connect to Vdd or Vss
8	VDD	Positive supply

Table 1-3 Alternate Cloning Pin Functions		
Pin	Name	Function
2	SCK	Serial clone data clock
6	SDI	Serial clone data in
7	SDO	Serial clone data out

## 1 - OVERVIEW

The QT300 is a digital burst mode charge-transfer (QT) capacitance-to-digital converter (CDC) designed for applications requiring raw signal information such as fluid level sensing and distance gauging; it outputs raw digital signal data over a serial interface. The output data is in a 16-bit format; signal levels depend on load ( $C_x$ ) and the sampling capacitor value ( $C_s$ ).

### 1.1 Basic Operation

The QT300 does no internal signal processing; data is simply returned via one of two serial port types.

There are two basic types of serial interface: 4-wire SPI and a simple single wire ('1W') UART. The SPI interface allows multiple devices to be connected on one SPI bus, while the 1W UART requires that the controller have one dedicated pin for each QT300. There are two types of SPI mode, master and slave.

The type of serial port and its mode can be selected via the cloning process using a QTM300CA programming adapter.

The QT300 operates only on request from a host device. After initiation via a trigger signal, the QT300 generates an acquisition burst and sends the resulting raw signal data back via one of the serial modes.

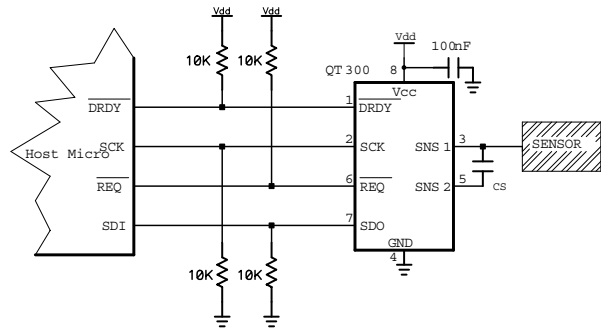

Figure 1-1 Basic QT300 Circuit in SPI mode.

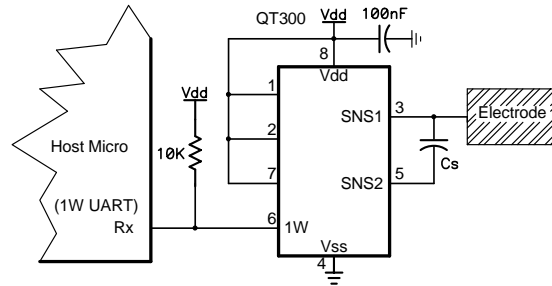

Figure 1-2 Basic QT300 Circuit in UART mode.

### 1.2 CS / $C_x$ Dependency

The value returned is a direct function of  $C_s$ , the fixed sample capacitor and  $C_x$ , the unknown or variable capacitance. These two values influence device sensitivity and response time, making them very important parameters.

Sensitivity is also a function of electrode size, shape, orientation, the composition and aspect of the object being sensed, the thickness and composition of any dielectric overlaying the electrode, and the degree of mutual coupling between the electrode and the object being sensed.

The response follows a logarithmic curve (Figures 7-4, 7-5, Page 10); each doubling of  $C_s$  increases the signal level and differential sensitivity by a factor of 2. Likewise, doubling  $C_x$  reduces the signal level and differential sensitivity by a factor of 2.

## 2 - Timing

Figure 2-1 shows the basic QT300 acquisition timing parameters. The basic timing parameters are:

$T_{bd}$	<b>Burst duration</b>	(2.1)
$T_{acq}$	<b>Acquire response time</b>	(2.2)
$T_{bs}$	<b>Burst Spacing</b>	(2.3)

### 2.1 $T_{bd}$ - Burst duration

The burst duration depends on the values of  $C_s$  and  $C_x$  and to a lesser extent,  $V_{dd}$ . The burst is composed of charge-transfer cycles operating at about 240kHz.

The length of this burst is an important parameter as it is directly related to the signal value. The burst duration also affects the response time of the sensor; the larger  $C_s$  is, the longer the burst, the slower the possible acquisition rate.

## 2.2 Tacq - Acquire Response Time

The time from the  $/REQ$  or  $1W$  line going low until the completion of data transmission is  $Tacq$ .  $Tacq$  depends on the acquisition burst length as well as the serial transmission time.

**SPI Mode:** In SPI mode  $Tacq$  depends in part on the serial clock speed and the space between the returned high and low bytes. In SPI slave mode the clock speed and the inter-byte spacing time  $Tbdly$  is determined by the host. In SPI Master mode these timings are set by Setup parameters  $SCD$  and  $MLS$ .

**1W mode:**  $Tacq$  depends in part on the Baud rate as well as the inter-byte spacing. The Baud rate is auto-set by the trigger pulse width; the inter-byte spacing is set by the  $MLS$  parameter. See Section 4.

## 2.3 Tbs - Burst Spacing

Burst spacing is the time from the start of one acquisition burst to the start of the next burst. It depends on the host's trigger rate on the  $/REQ$  or  $1W$  pin. The QT300 only acquires when the host requests it.

While waiting for a new request the part is in a low power mode.

# 3 - SPI Port

## 3.1 SPI Specifications

The QT300 can operate in master or slave mode, and thus is compatible with virtually all SPI-capable microcontrollers. The SPI interface has the following specifications:

Max clock rate, $F_{ckm}$	40KHz (master mode)
Max clock rate, $F_{cks}$	40KHz (slave mode)
Data length	2 bytes (16 bits total)
Inter-byte delay	$\geq 8\mu s$ (master mode)*
	$\geq 12\mu s$ (slave mode)
Clock idle logic level	Low or High*
Clock edge	Data out on rising or falling edge*
Data sequence	High byte first, MSB first

\*Determined by Setups

The host can clock the SPI at any rate up to and including the maximum. The maximum clock rate of the part in Master mode is determined in Setups via cloning.

## 3.2 Protocol Overview

The QT300 only transmits data on request, after an acquisition burst. The host requests an acquire by setting the  $/REQ$  line low for at least  $30\mu s$ ; the device then acquires. When finished, the  $DRDY$  line is pulled low by the QT300 to indicate it is ready to send data. (Figure 2-1). The transfer is done as two bytes, with the highest byte transferred first.

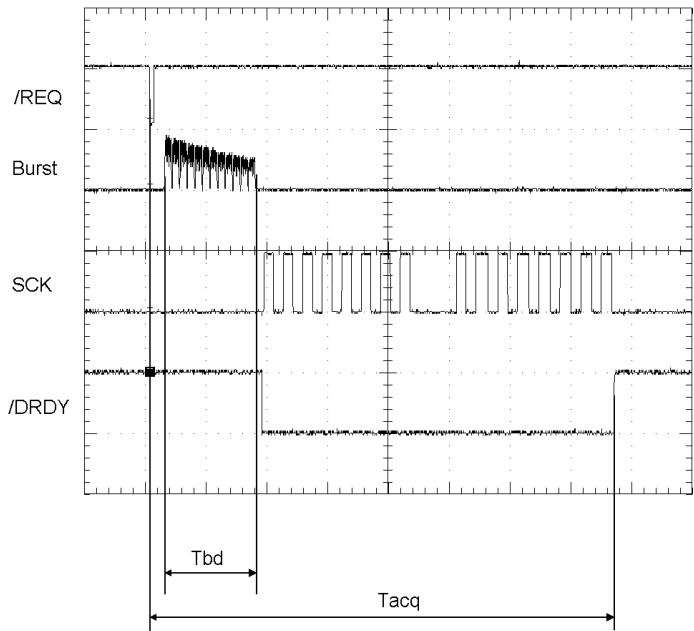

Figure 2-1 Signal Acquisition - Slave SPI Mode

In master mode,  $/DRDY$  goes high between bytes for the period determined by Setup parameter  $MLS$ ; this is a multiple of  $6\mu s$ .

When not communicating, all SPI lines float to allow multiple chips to connect over the same SPI lines. A pullup or pulldown resistor is required on SCK depending on the selected clock phase, determined by Setups. A pullup resistor is required on  $/DRDY$ .  $/REQ$  may require a pullup if the host ever allows this line to float.

## 3.3 SPI Bus Sharing

All SPI float transfers making it possible to have several QT300 devices (or other unrelated devices) share the SPI control signals (Figure 3-1).

Each part needs an individual  $/REQ$  line, but  $/DRDY$ , SCK and SDO can be connected together.

## 3.4 SPI Slave Mode

Refer to Figure 7-1 and Table 7-1, page 8.

In SPI Slave mode,  $/DRDY$  is used to let the host know when data is ready for collection in response to a request so that the host can clock over the data.

SPI Slave mode uses 4 signals:

**$/REQ$**  - Request Acquisition Input; Active low input-only.

When  $/REQ$  is pulled low, the QT300 wakes and starts an acquire. The IC will transmit the resulting data only when the acquire has finished.

**$/REQ$  should return high before the end of the burst.** If  $/REQ$  is still low at the end of the burst the part will go into Setup mode. The minimum duration of  $/REQ$  is  $30\mu s$ .

**Figure 3-1 Multiple QT300's on the same SPI port**

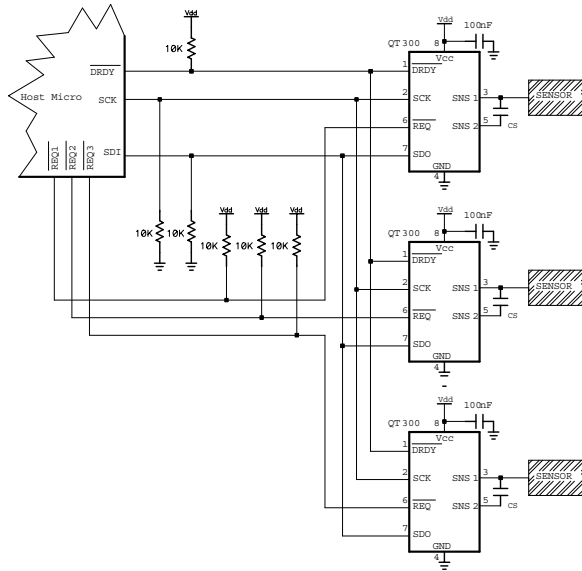

**SDO** - Serial Data Output; Output-only. This is the data output to the host during an SPI transfer. When not in use, this pin floats. This pin should be connected to the SDI input pin of the host device.

**SCK** - SPI clock; Idle high or idle low; input-only SPI clock from the host. The idle state is determined in Setups by the serial mode (SM) parameter.

**If SM is set for idle-low SCK:** Data is shifted out of the QT300 on the rising edge of SCK and should be shifted into the host on the falling edge of SCK.

**If SM is set for idle-high SCK:** Data is shifted out of the QT300 on the falling edge of SCK and should be shifted into the host on the rising edge of SCK.

The maximum clock speed is 40kHz, and the timings should obey the parameters Tskh and Tskl in Table 7-1.

**/DRDY** - Data Ready; active low output only. This indicates to the host that the device is ready to send data back to the host. During idle times this pin floats and therefore must be connected to a pullup resistor. The host must wait until /DRDY goes low before starting an SPI transfer.

Between the high and low byte clockings, the host should observe a delay of  $\geq 12\mu\text{s}$ .

A typical **SPI slave mode** communication sequence is:

- 1) Host pulses /REQ low for  $\geq 30\mu\text{s}$  to initiate an acquire.
- 2) QT300 acquires a signal in response to /REQ.
- 3) QT300 pulls /DRDY low when ready to send data back.
- 4) Host detects /DRDY is low.
- 5) Host clocks out the high byte of data from the QT300.
- 6) Host waits for  $\geq 12\mu\text{s}$ .
- 7) Host clocks out the low byte of data from the QT300.
- 8) QT300 releases /DRDY to float high.

### 3.5 SPI Master Mode

Refer to Figure 7-2 and Table 7-2, page 8.

In master SPI mode the QT300 generates the clock signal after an acquire initiated from the host via the /REQ line. The clock speed and the spacing between the two bytes is set via the Setup process (Section 6).

**SCD** setup parameter determines the master-mode clock rate. The default value is 55 (resulting in a 2.55KHz rate). The relationship is:

$$F_{\text{scd}} = 1200 / (30 + (\text{SCD} \times 8)) \text{ in KHz}$$

Where SCD = 0..255

**MLS** setup parameter determines the spacing between the two return bytes; this can be important to allow a slow host device to recover from receiving the first byte to prevent an overrun. The default value is 148 (resulting in a 500 $\mu\text{s}$  gap). The relationship is:

$$T_{\text{mls}} \text{ (in } \mu\text{s)} = (10 + \text{MLS} \times 4) / 1.2$$

Where MLS = 0..255 (from user setup MLS)

Master SPI mode requires at least 3 signals to operate:

**/REQ** - Request Acquisition Input; Active low input-only.

When /REQ is pulled low, the QT300 wakes and starts an acquire. The IC will transmit the resulting data only when the acquire has finished.

**/REQ must return high before the end of the burst.** If /REQ is still low at the end of the burst the part goes into Setup mode. The minimum duration of /REQ is 30 $\mu\text{s}$ .

**SDO** - Serial Data Output; Idle low output-only. This is the data output to the host during an SPI transfer. When not in use, this pin floats. This pin should be connected to the SDI input pin of the host device.

**SCK** - SPI clock; Idle high or idle low, output-only. The idle state is determined in Setups by the serial mode (SM) parameter.

**If SM is set for idle-low SCK:** Data is shifted out of the QT300 on the rising edge of SCK and should be shifted into the host on the falling edge of SCK.

**If SM is set for idle-high SCK:** Data is shifted out of the QT300 on the falling edge of SCK and should be shifted into the host on the rising edge of SCK.

The maximum clock speed is 40kHz, and the timings should obey the parameters Tskh and Tskl in Table 7-2.

**/DRDY** - Data Ready (Optional); active low output only. This indicates to the host that the device is ready to send data

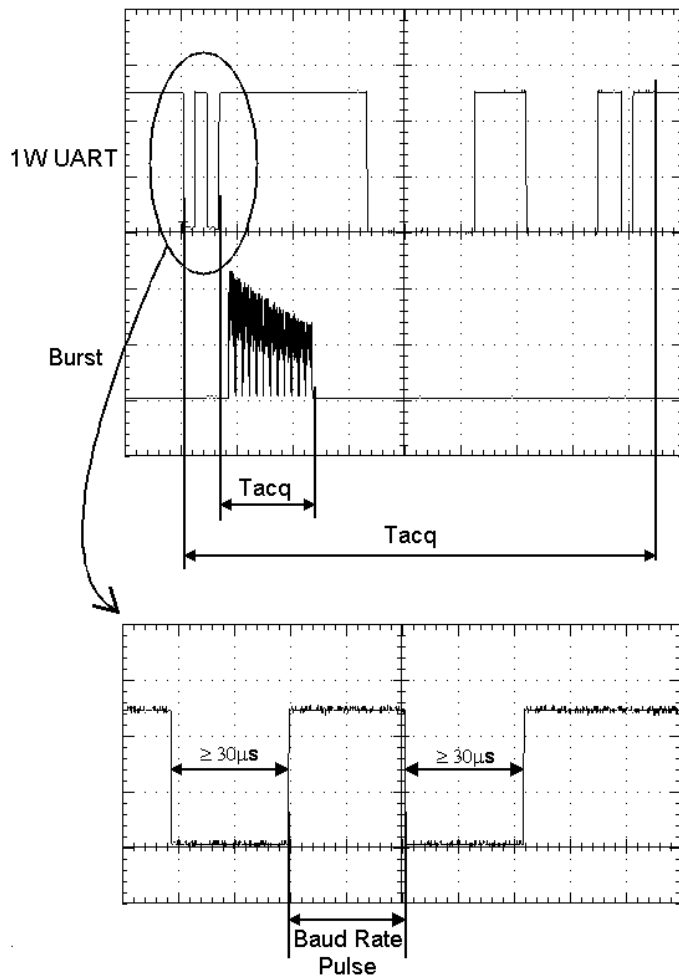

Figure 4-1 UART and Trigger Pulse Signal.

back to the host. During idle times this pin floats and therefore must be connected to a pullup resistor.

The DRDY line can be used as a Slave Select line (SS). The host does not need this line to operate in many cases. DRDY can be used to 'frame' byte transmissions.

Between bytes /DRDY will go high for a period determined by the MLS setup parameter; the minimum period is 8.3μs.

A typical Master mode SPI sequence is:

- 1) Host pulses /REQ low for  $\geq 30\mu\text{s}$ .
- 2) QT300 acquires a signal in response to /REQ.
- 3) QT300 pulls /DRDY low when ready to send data.
- 4) Host detects /DRDY low and prepares to receive data.
- 5) QT300 clocks out first byte of data (MSB).
- 6) QT300 sets /DRDY high for a duration determined by Setup parameter MLS.
- 7) QT300 pulls /DRDY low.
- 8) QT300 clocks out the low byte (LSB).
- 9) QT300 releases /DRDY to float high.

## 4 Single-Wire (1W) UART Interface

The single wire ('1W') UART option allows all communications to take place over a single bidirectional line with a 10K pullup resistor. The host device triggers the QT300 to acquire by means of a pulse sent to the QT300 over the wire. The Baud rate is established by the width of this pulse; the pulse width establishes the bit rate of the UART transmission to follow. The QT300 then acquires, and responds by sending two bytes of data back over the 1W line with a delay between the bytes as determined by parameter MLS.

1W operation permits a device to be controlled from a single pin on a host controller, using either a hardware or software UART. Several QT300's can coexist on a single host pin, provided there is some logic steering.

This mode is set via the cloning process using parameter SM (see Section 6).

### 4.1 1W UART Specifications

The QT300 operates in 1W UART mode with the following specifications:

Baud rate range	4,800 to 9,600 bits/sec
Data length	2 bytes (16 bits total)
Stop bit	1 (each byte)
Parity	None
Idle state	High

The 1W line must have a pullup resistor on it (i.e. 10K), or 1W communications will not function.

### 4.2 UART 1W Protocol

The QT300 acquires and transmits only on request. The sequence is:

- 1) The host generates a pulse on the 1W pin; the pulse width must match the Baud rate (bit width) of the expected return Baud rate from the QT300. This pulse actually sets the Baud rate each time, and so it can vary from one acquire to another. See Section 4.3 and Figure 4-1.
- 2) The 1W pulse width is measured by the QT300 to determine the Baud rate.
- 3) The host floats 1W high.
- 4) The QT300 acquires the signal to completion.
- 5) QT300 returns data in the following UART format:
  - start bit (low)
  - 8 bits, high byte
  - stop bit (high)
  - delay (determined by MLS setup)
  - start bit (low)
  - 8 bits, low byte
  - stop bit (high)
- 6) The QT300 floats the 1W line and enters idle mode.

### 4.3 Trigger pulse description

The part wakes from low power mode when the first negative edge is detected on the 1W pin (Figure 4-1, bottom). The negative pulse must be at least 30µs wide.

The host then generates the positive pulse that actually sets the Baud rate. The QT300 measure this pulse and uses its length to set the Baud bit (shift out) rate. 30µs (or more) of logic-low must follow this pulse.

The host must then float the 1W line to allow the QT300 to start the signal acquisition.

## 5 Circuit Guidelines

### 5.1 Sample capacitors

Cs capacitors can be virtually any plastic film or low to medium-K ceramic capacitor. The normal usable Cs range is from 1nF ~ 500nF depending on the sensitivity required; larger values of Cs require higher stability to ensure low drift. Acceptable capacitor types include NP0 or COG ceramic, PPS film, and Y5E and X7R ceramics in that order.

### 5.2 Power Supply

#### 5.2.1 STABILITY

The QT300 makes use of the power supply as a reference voltage. The acquired signal will shift slightly with changes in Vdd; Vdd fluctuations often happen when additional loads are switched on or off such as LEDs etc.

If the power supply is shared with another electronic system, care should be taken to assure that the supply is free of spikes, sags, and surges. It is best practice to use a regulator just for the QT300 (or one for a set of QT300's).

#### 5.2.2 SUPPLY REQUIREMENTS

Vdd can range from 2 to 5 volts nominal. Current drain will vary depending on Vdd. During writing of the internal EEPROM, Vdd must be at least 2.2 volts.

If desired, the supply can be regulated using a conventional regulator, for example CMOS LDO regulators, or standard 78Lxx-series 3-terminal devices.

For proper operation a 100nF (0.1µF) ceramic bypass capacitor must be used between Vdd and Vss; the bypass cap should be placed very close to the Vdd and Vss pins.

## 5.3 PCB LAYOUT

### 5.3.1 GROUND PLANES

The use of ground planes around the device is encouraged for noise reasons, but ground or power should not be coupled too close to the sense pins in order to reduce Cx load. Likewise, the traces leading from the sense pins to the electrode should not be placed directly over a ground plane; rather, the ground plane should be relieved by at least 3 times the width of the sense traces directly under it, with periodic thin bridges over the gap to provide ground continuity.

### 5.3.2 NOISE SYNCHRONIZATION

External fields can cause interference leading to a noisy and unstable signal. The most common external fields usually are from AC mains power.

The /REQ line of the QT300 can be used to synchronize the acquisition to a repetitive external source of interference such as the power line frequency in order to dramatically reduce signal noise.

If line frequency is present near the sensors, this feature should be used.

## 6 Parameter Setups Cloning

A special interface is provided to allow user-defined Setups to be loaded into internal eeprom or read back out for development and production purposes.

The QTM300CA cloning board in conjunction with QT3View software simplifies the Setups cloning process greatly. The E3A eval board has been designed with a connector to facilitate direct connection with the QTM300CA. The QTM300CA in turn connects to any PC with a serial port which can run QT3View software (included with the QTM300CA and available free on Quantum's web site).

The connections required for cloning are shown in Figure 6-1. Further information on the cloning process can be found in the QTM300CA instruction guide. The parameters which can be altered are shown in Table 7-4.

The internal eeprom has a life expectancy of 100,000 erase/write cycles and the minimum voltage for a write cycle is 2.2 Volts.

A serial interface specification for the device can be obtained by contacting Quantum.

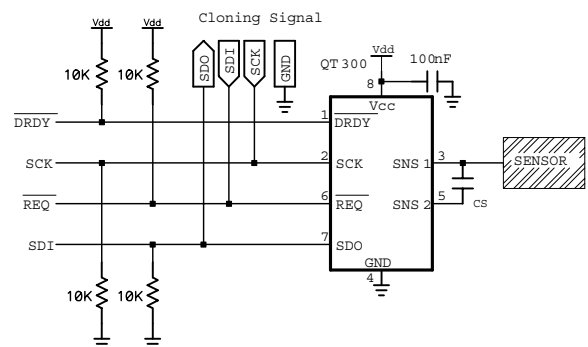

Figure 6-1 Clone interface wiring

## 7 Electrical specifications

### 7.1 ABSOLUTE MAXIMUM SPECIFICATIONS

Operating temp. ....	as designated by suffix
Storage temp. ....	-65°C to +125°C
V <sub>DD</sub> .....	-0.5 to +6V
Max continuous pin current, any control or drive pin.....	±40mA
Short circuit duration to ground, any pin.....	infinite
Short circuit duration to V <sub>DD</sub> , any pin.....	infinite
Voltage forced onto any pin.....	-1V to (V <sub>DD</sub> + 0.5) Volts

### 7.2 RECOMMENDED OPERATING CONDITIONS

V <sub>DD</sub> .....	+2 to 5V
V <sub>DD</sub> min required to reprogram eeprom Setups.....	+2.2V
Short-term supply ripple+noise.....	±5mV
Long-term supply stability.....	±100mV
Cs value.....	1 to 500nF
Cx value.....	0 to 100pF

### 7.3 AC SPECIFICATIONS

V<sub>DD</sub> = 3.0, T<sub>a</sub> = recommended operating range, C<sub>s</sub>=100nF unless noted

Parameter	Description	Min	Typ	Max	Units	Notes
T <sub>PC</sub>	Charge/transfer duration		830		ns	
T <sub>BL</sub>	Burst length	0.5		25	ms	C <sub>s</sub> = 4.7nF to 200nF; C <sub>x</sub> = 0
T <sub>RQP</sub>	Request pulse	30			µs	

### 7.4 DC specifications

V<sub>DD</sub> = 3.0V, C<sub>s</sub> = 10nF, C<sub>x</sub> = 5pF, T<sub>a</sub> = recommended range, unless otherwise noted

Parameter	Description	Min	Typ	Max	Units	Notes
V <sub>DD</sub>	Supply voltage	2		5.5	V	
I <sub>DD</sub>	Supply current	60		1,500	µA	Dependent on duty cycle
V <sub>IL</sub>	Input low voltage			0.3 V <sub>DD</sub>	V	V <sub>DD</sub> = 2.5 to 5.0V
V <sub>IH</sub>	Input high voltage	0.6 V <sub>DD</sub>			V	V <sub>DD</sub> = 2.5 to 5.0V
V <sub>OL</sub>	Low output voltage			0.4	V	
V <sub>OH</sub>	High output voltage	V <sub>DD</sub> -0.6			V	
A <sub>R</sub>	Acquisition resolution			16	bits	
S	Resolution per bit	1,000		7	fF	Figs 7-4, 7-5

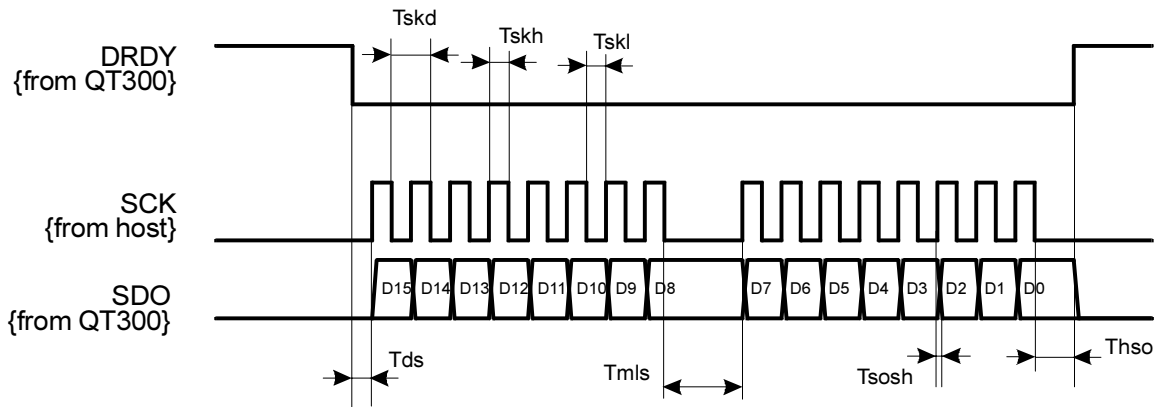

Figure 7-1 SPI Slave Mode

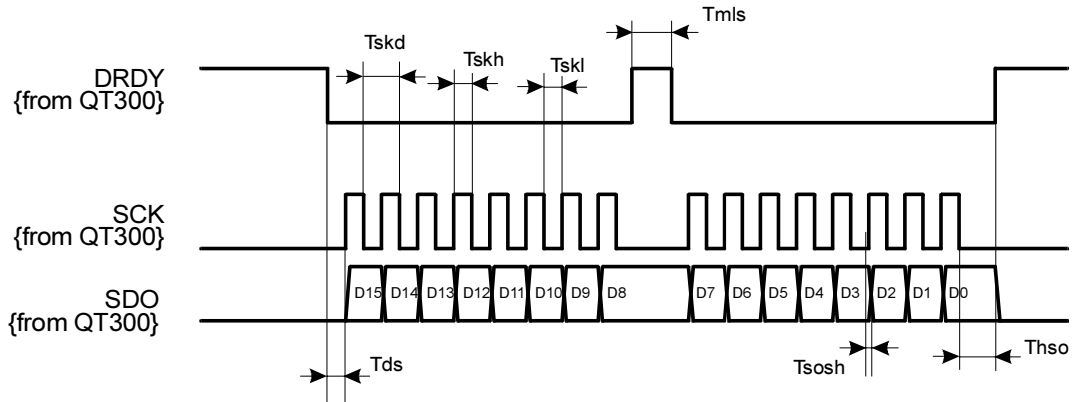

Figure 7-2 SPI Master Mode

Symbol	Parameter	min	max	Units
$T_{SKD}$	Clock Duration	25	-	$\mu\text{s}$
$T_{SKH}$	SCK High Duration	13	-	$\mu\text{s}$
$T_{SKL}$	SCK Low Duration	12	-	$\mu\text{s}$
$T_{SOSH}$	SCK High To SDO Ready Setup Time	-	10	$\mu\text{s}$
$T_{HSO}$	SDO Hold Time	7	-	$\mu\text{s}$
$T_{MLS}$	MSB-LSB Spacing	12	1,000	$\mu\text{s}$
$T_{DS}$	DRDY Low To SCK High Delay	12	1,000	$\mu\text{s}$

Table 7-1 Slave SPI Timing

Symbol	Parameter	min	max	Units
$T_{SKD}$	Clock Duration	25	1,725	$\mu\text{s}$
$T_{SKH}$	SCK High Duration	12.5	862.5	$\mu\text{s}$
$T_{SKL}$	SCK Low Duration	12.5	862.5	$\mu\text{s}$
$T_{SOSH}$	SCK High To SDO Ready Setup Time	4	7	$\mu\text{s}$
$T_{HSO}$	SDO Hold Time	12.5	-	-
$T_{MLS}$	MSB-LSB Spacing	8.3	1,708	$\mu\text{s}$
$T_{DS}$	DRDY Low To SCK High Delay	12.5	-	-

Table 7-2 Master SPI Timing



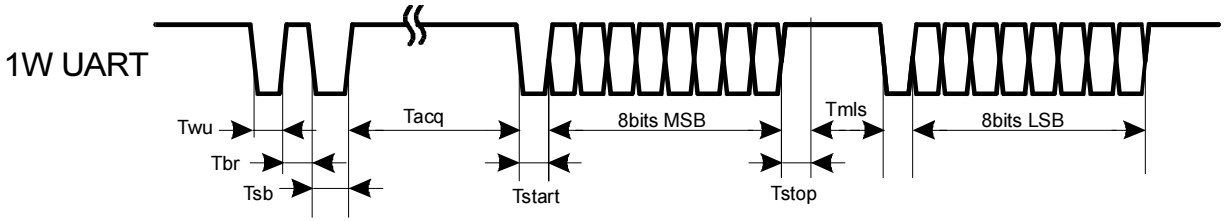

Figure 7-3 1W UART Mode

Symbol	Parameter	min	max	Notes	Units
Twu	Wake level	30	5,000	-	μs
Tbr	Baud set pulse	104	210	-	μs
Tsb	Baud end level	30	5,000	-	μs
	Baud rate range	4,800	9,600	-	-
	Baud rate match accuracy		2	-	%
Tacq	Acquisition time	-	400	Depends on Cs and Cx	ms
Tstart	Start pulse		Tbr	-	
Tstop	Stop pulse		Tbr	-	
Tmls	MSB-LSB spacing	8	850	-	μs
MSB	-		8 x Tbr	8 bits data, LSB first	μs
LSB	-		8 x Tbr		μs

Table 7-3 1W UART Timing

Description	Symbol	Valid Values	Default	Calculation / Notes	Unit	
Mode	SM	0	1W UART	3 Slave Clock Idle Low	-	-
		1	Master Clock Idle Low			
		2	Master Clock Idle High			
		3	Slave Clock Idle Low			
		4	Slave Clock Idle High			
Clock Speed	SCD	0 - 255	55	$T_{scd} = (30 + (SCD \times 8))/1.2$	μs	
MSB-LSB Spacing	MLS	0 - 255	148	$T_{mls} = (10 + (MLS \times 4))/1.2$	μs	

Table 7-4 Setups summary chart

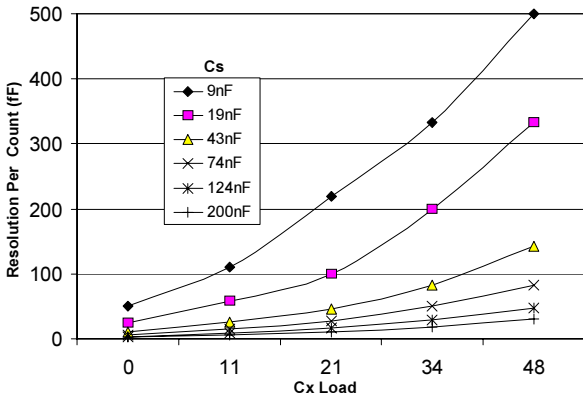

Figure 7-4 Typical resolution vs Cx & Cs;  
Vdd = 3.0 Volts

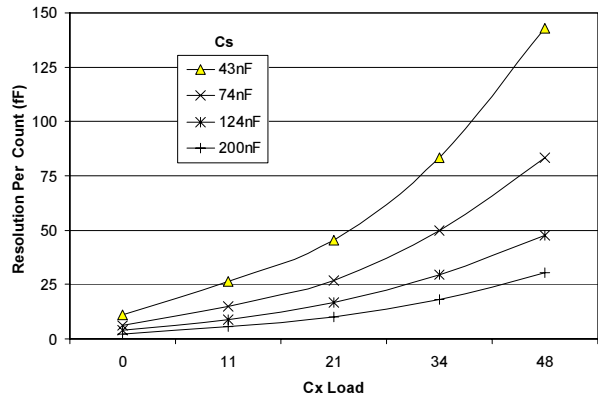

Figure 7-5 Typical resolution vs Cx & Cs;  
Vdd = 3.0 Volts

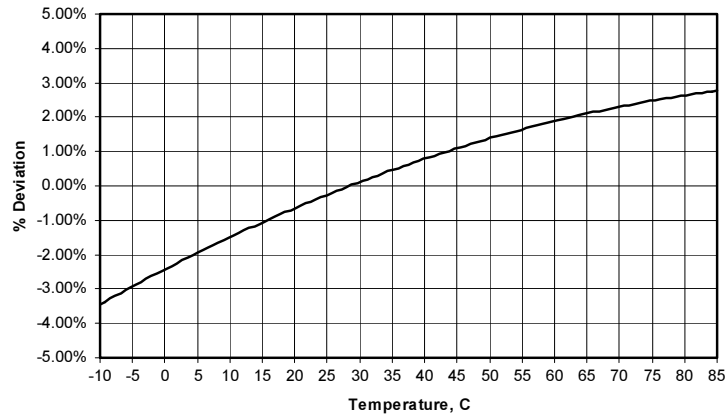

Figure 7-6 Typical Signal Deviation vs. Temperature  
Vdd = 5.0 Volts, Cx = 10pF, Cs = 5~200nF PPS Film

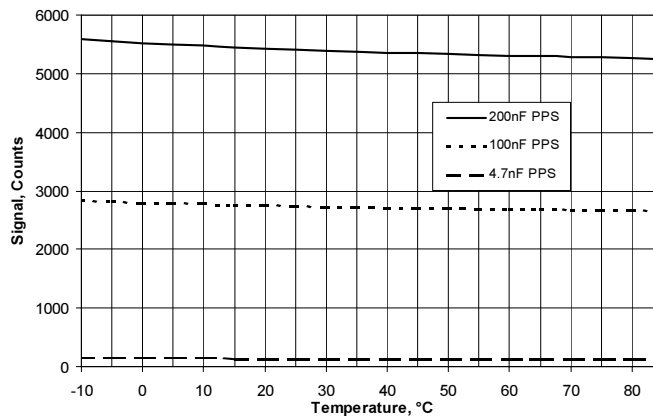
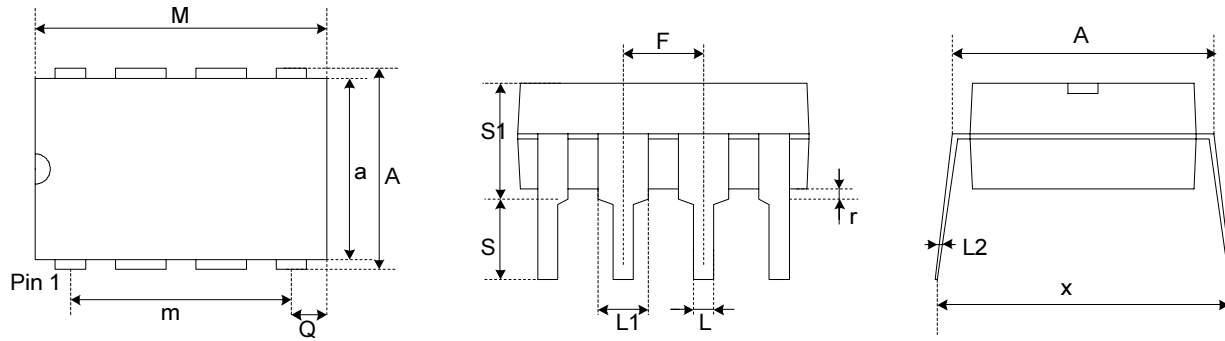
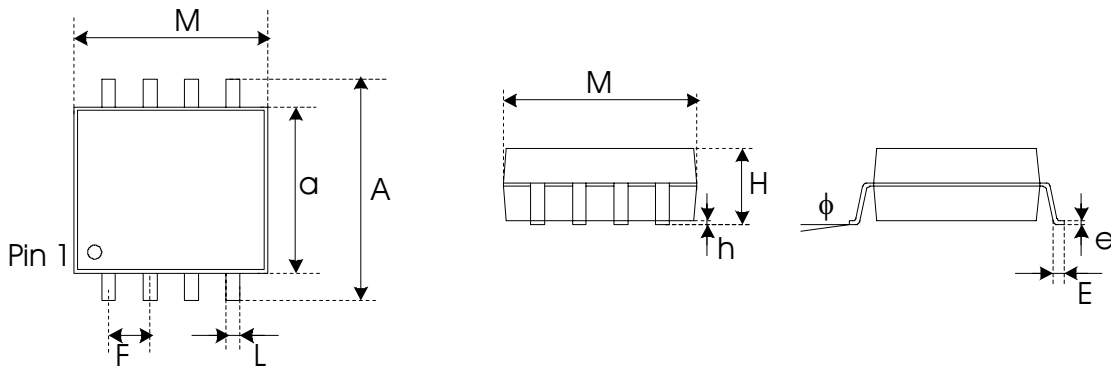

Figure 7-7 Typical Signal Vs. Cs & Temp  
Vdd = 5.0 Volts, Cx = 10pF, PPS film capacitors



Package type: 8-pin Dual-In-Line						
SYMBOL	Millimeters			Inches		
	Min	Max	Notes	Min	Max	Notes
a	6.1	7.11		0.24	0.28	
A	7.62	8.26		0.3	0.325	
M	9.02	10.16		0.355	0.4	
m	7.62	-	Typical	0.3	-	Typical
Q	0.69	0.94		0.027	0.037	
L	0.356	0.559		0.014	0.022	
L1	1.14	1.78		0.045	0.07	
L2	0.203	0.305		0.008	0.012	
F	2.54	-	BSC	0.1	-	BSC
r	0.38	-		0.015	-	
S	2.92	3.81		0.115	0.15	
S1	-	5.33		-	0.21	
x	-	10.9		-	0.43	



Package type: 8-pin Wide SOIC						
SYMBOL	Millimeters			Inches		
	Min	Max	Notes	Min	Max	Notes
a	5.21	5.41		0.205	0.213	
A	7.62	8.38		0.3	0.33	
M	5.16	5.38		0.203	0.212	
F	1.27	-	BSC	0.05	-	BSC
L	0.305	0.508		0.012	0.02	
h	0.102	0.33		0.004	0.013	
H	1.78	2.03		0.07	0.08	
e	0.178	0.254		0.007	0.01	
E	0.508	0.889		0.02	0.035	
phi	0°	8°		0°	8°	



Copyright © 2002 QRG Ltd. All rights reserved.  
Patented and patents pending

**Corporate Headquarters**  
1 Mitchell Point  
Ensign Way, Hamble SO31 4RF  
Great Britain

Tel: +44 (0)23 8056 5600 Fax: +44 (0)23 8045 3939

admin@qprox.com  
www.qprox.com

**North America**  
651 Holiday Drive Bldg. 5 / 300  
Pittsburgh, PA 15220 USA  
Tel: 412-391-7367 Fax: 412-291-1015

The specifications set out in this document are subject to change without notice. All products sold and services supplied by QRG are subject to our Terms and Conditions of sale and supply of services which are available online at [www.qprox.com](http://www.qprox.com) and are supplied with every order acknowledgement. QProx, QTouch, QMatrix, QLevel, and QSlide are trademarks of QRG. QRG products are not suitable for medical (including life-saving equipment), safety or mission critical applications or other similar purposes. Except as expressly set out in QRG's Terms and Conditions, no licenses to patents or other intellectual property of QRG (express or implied) are granted by QRG in connection with the sale of QRG products or provision of QRG services. QRG will not be liable for customer product design and customers are entirely responsible for their products and applications which incorporate QRG's products.