



PCA9549

Octal bus switch with individually I²C-bus controlled enables

Rev. 01 — 11 July 2006

Product data sheet

1. General description

The PCA9549 provides eight bits of high speed TTL-compatible bus switching controlled by the I²C-bus. The low ON-state resistance of the switch allows connections to be made with minimal propagation delay. Any individual A to B channel or combination of channels can be selected via the I²C-bus, determined by the contents of the programmable Control register. When the I²C-bus bit is HIGH (logic 1), the switch is on and data can flow from Port A to Port B, or vice versa. When the I²C-bus bit is LOW (logic 0), the switch is open, creating a high-impedance state between the two ports, which stops the data flow.

An active LOW reset input ($\overline{\text{RESET}}$) allows the PCA9549 to recover from a situation where the I²C-bus is stuck in a LOW state. Pulling the $\overline{\text{RESET}}$ pin LOW resets the I²C-bus state machine and causes all the bits to be open, as does the internal power-on reset function.

Three address pins allow up to eight devices on the same bus.

2. Features

- 8-bit bus switch (CBT)
- 5 Ω switch connection between two ports
- I²C-bus interface logic; compatible with SMBus standards
- Active LOW $\overline{\text{RESET}}$ input
- 3 address pins allowing up to 8 devices on the I²C-bus
- Bit selection via I²C-bus, in any combination
- Power-up with all bits deselected
- Low R_{on} switches
- No glitch on power-up
- Supports hot insertion
- Low standby current
- Operating power supply voltage range of 2.3 V to 5.5 V
- 5 V tolerant inputs
- 0 Hz to 400 kHz clock frequency
- ESD protection exceeds 2000 V HBM per JESD22-A114, 200 V MM per JESD22-A115 and 1000 V CDM per JESD22-C101
- Latch-up testing is done to JEDEC Standard JESD78 which exceeds 100 mA
- Packages offered: SO24, TSSOP24, HVQFN24

PHILIPS

3. Ordering information

Table 1. Ordering information

Type number	Package		Version
	Name	Description	
PCA9549D	SO24	plastic small outline package; 24 leads; body width 7.5 mm	SOT137-1
PCA9549PW	TSSOP24	plastic thin shrink small outline package; 24 leads; body width 4.4 mm	SOT355-1
PCA9549BS	HVQFN24	plastic thermal enhanced very thin quad flat package; no leads; 24 terminals; body 4 × 4 × 0.85 mm	SOT616-1

3.1 Ordering options

Table 2. Ordering options

Type number	Topside mark	Temperature range
PCA9549D	PCA9549D	-40 °C to +85 °C
PCA9549PW	PCA9549	-40 °C to +85 °C
PCA9549BS	9549	-40 °C to +85 °C

4. Block diagram

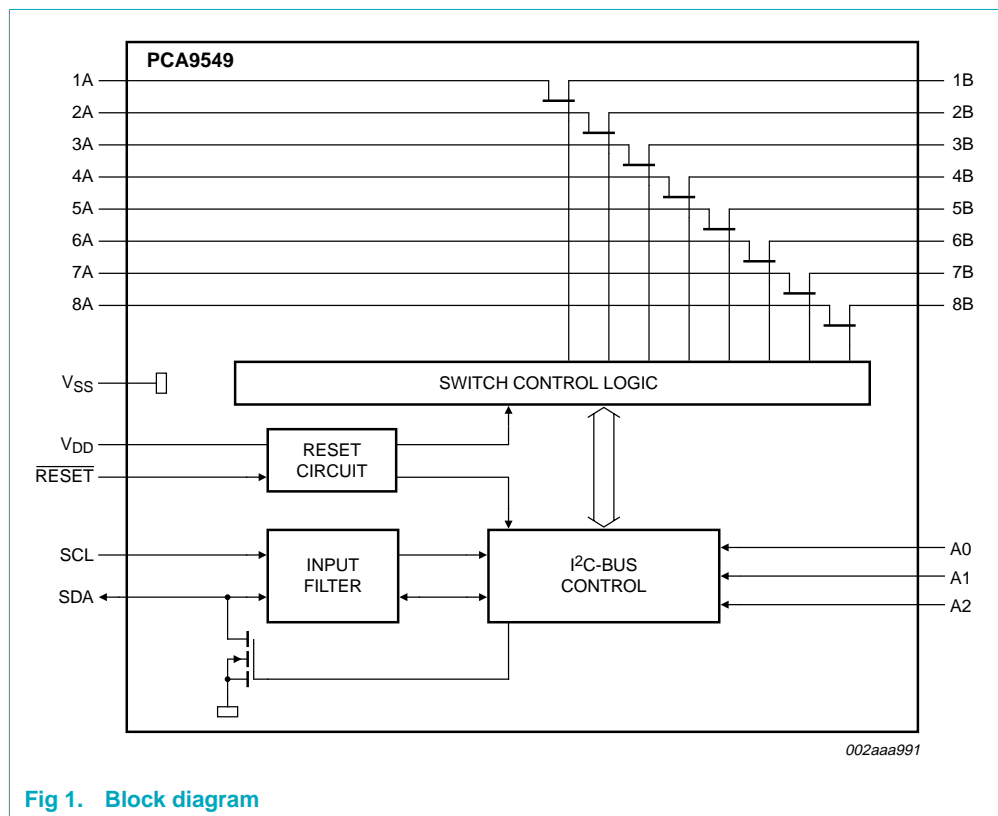

Fig 1. Block diagram

5. Pinning information

5.1 Pinning

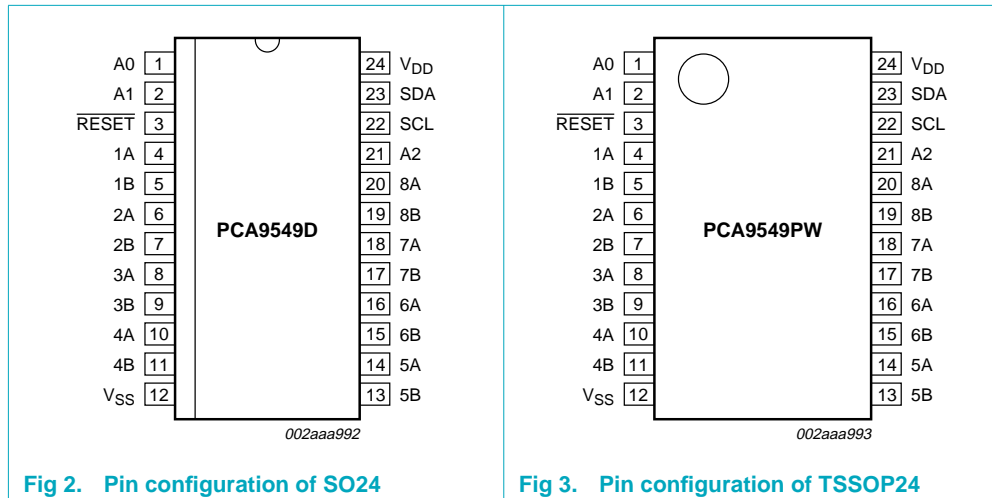

Fig 2. Pin configuration of SO24

Fig 3. Pin configuration of TSSOP24

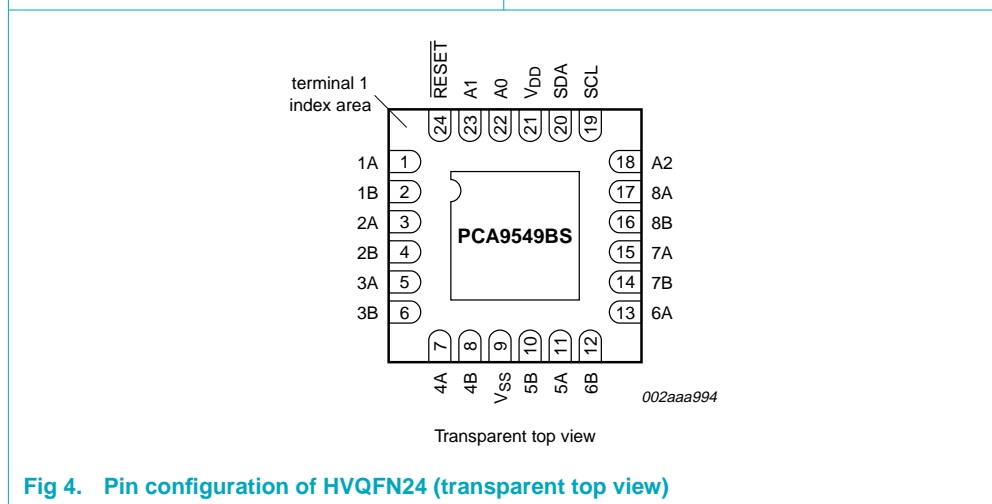

Fig 4. Pin configuration of HVQFN24 (transparent top view)

5.2 Pin description

Table 3. Pin description

Symbol	Pin		Description
	SO, TSSOP	HVQFN	
A0	1	22	address input 0
A1	2	23	address input 1
$\overline{\text{RESET}}$	3	24	active LOW reset input
1A	4	1	input
1B	5	2	output
2A	6	3	input
2B	7	4	output
3A	8	5	input
3B	9	6	output
4A	10	7	input
4B	11	8	output
V _{SS}	12	9 ^[1]	supply ground
5B	13	10	output
5A	14	11	input
6B	15	12	output
6A	16	13	input
7B	17	14	output
7A	18	15	input
8B	19	16	output
8A	20	17	input
A2	21	18	address input 2
SCL	22	19	serial clock line
SDA	23	20	serial data line
V _{DD}	24	21	supply voltage

[1] HVQFN package die supply ground is connected to both the V_{SS} pin and the exposed center pad. The V_{SS} pin must be connected to supply ground for proper device operation. For enhanced thermal, electrical, and board-level performance, the exposed pad needs to be soldered to the board using a corresponding thermal pad on the board, and for proper heat conduction through the board thermal vias need to be incorporated in the PCB in the thermal pad region.

6. Functional description

6.1 Device addressing

Following a START condition, the bus master must output the address of the slave it is accessing. The address of the PCA9549 is shown in Figure 5. To conserve power, no internal pull-up resistors are incorporated on the hardware selectable address pins and they must be pulled HIGH or LOW.

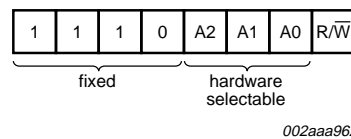

Fig 5. Slave address

The last bit of the slave address defines the operation to be performed. When set to logic 1 a read is selected, while a logic 0 selects a write operation.

6.2 Control register

Following the successful acknowledgement of the slave address, the bus master will send a byte to the PCA9549, which will be stored in the Control register. If multiple bytes are received by the PCA9549, it will save the last byte received. This register can be written and read via the I²C-bus.

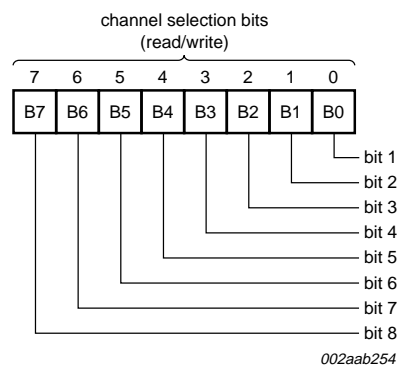

Fig 6. Control register

6.2.1 Control register definition

One or several bits are selected by the contents of the Control register. This register is written after the PCA9549 has been addressed. The entire control byte is used to determine which bit is to be selected. When a bit is selected to close, the bit will close after the Acknowledge has been placed on the I²C-bus.

Table 4. Control register

Write = channel selection; read = channel status.

B7	B6	B5	B4	B3	B2	B1	B0	Command
X	X	X	X	X	X	X	0	bit 1 disabled
							1	bit 1 enabled
X	X	X	X	X	X	0	X	bit 2 disabled
						1		bit 2 enabled
X	X	X	X	X	0	X	X	bit 3 disabled
					1			bit 3 enabled
X	X	X	X	0	X	X	X	bit 4 disabled
				1				bit 4 enabled
X	X	X	0	X	X	X	X	bit 5 disabled
			1					bit 5 enabled
X	X	0	X	X	X	X	X	bit 6 disabled
		1						bit 6 enabled
X	0	X	X	X	X	X	X	bit 7 disabled
	1							bit 7 enabled
0	X	X	X	X	X	X	X	bit 8 disabled
1								bit 8 enabled

[1] Several bits can be enabled at the same time. For example, B7 = 0, B6 = 1, B5 = 0, B4 = 0, B3 = 1, B2 = 1, B1 = 0, B0 = 0, means that bit 8, bit 6, bit 5, bit 2, and bit 1 are disabled and bit 7, bit 4, and bit 3 are enabled.

6.3 RESET input

The $\overline{\text{RESET}}$ input is an active LOW signal which may be used to recover from a bus fault condition. By asserting this signal LOW for a minimum of $t_{w(\text{rst})L}$, the PCA9549 will reset its registers and I²C-bus state machine and will open all bits. The $\overline{\text{RESET}}$ input must be connected to V_{DD} through a pull-up resistor.

6.4 Power-on reset

When power is applied to V_{DD}, an internal Power-On Reset (POR) holds the PCA9549 in a reset state until V_{DD} has reached V_{POR}. At this point, the reset condition is released and the PCA9549 registers and I²C-bus state machine are initialized to their default states, all zeroes causing all the bits to be open (high-impedance state).

6.5 CBT characteristic over V_{DD} range

The bus switch is optimized at 5.0 V but can operate over the entire supply range with lower V_{O(sw)} voltage and higher gate resistance.

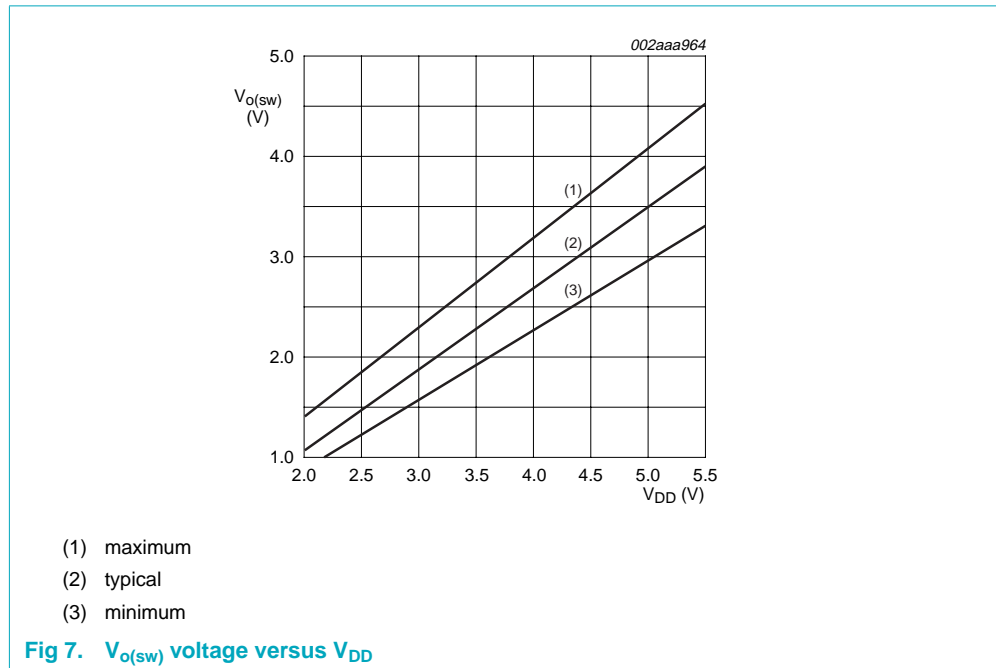

[Figure 7](#) shows the voltage characteristics of the pass gate transistors (note that the PCA9549 is only tested at the points specified in [Section 9 "Static characteristics"](#)). In order for the PCA9549 to act as a voltage translator, the $V_{o(sw)}$ voltage should be equal to, or lower than the lowest bus voltage. For example, if the main bus was running at 5 V, and the downstream buses were 3.3 V and 2.7 V, then $V_{o(sw)}$ should be equal to or below 2.7 V to effectively clamp the downstream bus voltages. Looking at [Figure 7](#), we see that $V_{o(sw)}$ (maximum) will be at 2.7 V when the PCA9549 supply voltage is 3.5 V or lower so the PCA9549 supply voltage could be set to 3.3 V. Pull-up resistors can then be used to bring the bus voltages to their appropriate levels (see [Figure 16](#)).

7. Characteristics of the I²C-bus

The I²C-bus is for 2-way, 2-line communication between different ICs or modules. The two lines are a serial data line (SDA) and a serial clock line (SCL). Both lines must be connected to a positive supply via a pull-up resistor. Data transfer may be initiated only when the bus is not busy.

7.1 Bit transfer

One data bit is transferred during each clock pulse. The data on the SDA line must remain stable during the HIGH period of the clock pulse as changes in the data line at this time will be interpreted as control signals (see [Figure 8](#)).

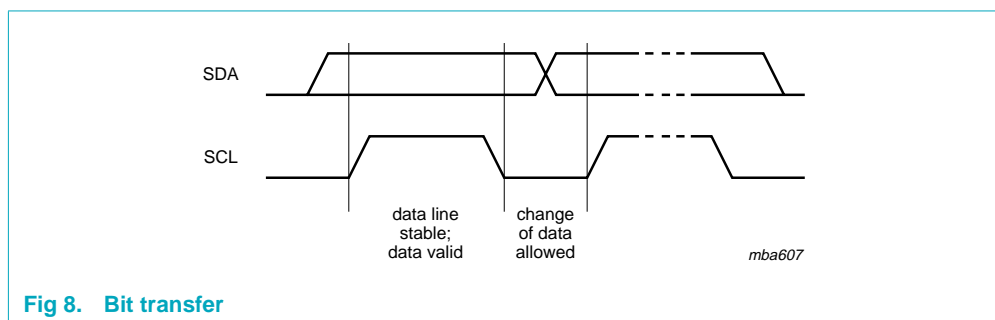

Fig 8. Bit transfer

7.1.1 START and STOP conditions

Both data and clock lines remain HIGH when the bus is not busy. A HIGH-to-LOW transition of the data line while the clock is HIGH is defined as the START condition (S). A LOW-to-HIGH transition of the data line while the clock is HIGH is defined as the STOP condition (P) (see [Figure 9](#)).

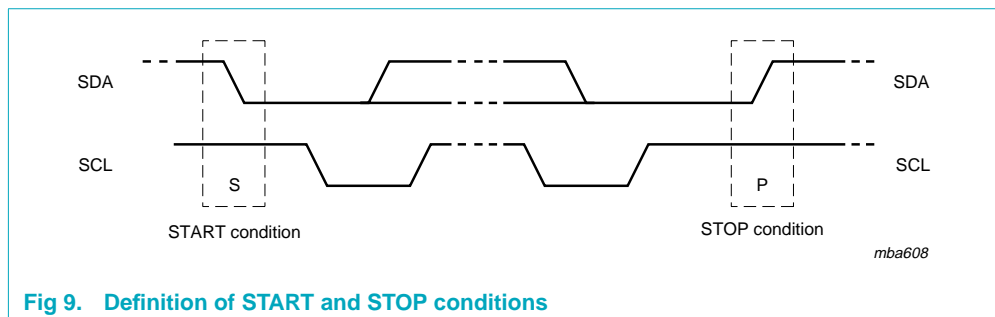

Fig 9. Definition of START and STOP conditions

7.2 System configuration

A device generating a message is a 'transmitter'; a device receiving is the 'receiver'. The device that controls the message is the 'master' and the devices which are controlled by the master are the 'slaves' (see [Figure 10](#)).

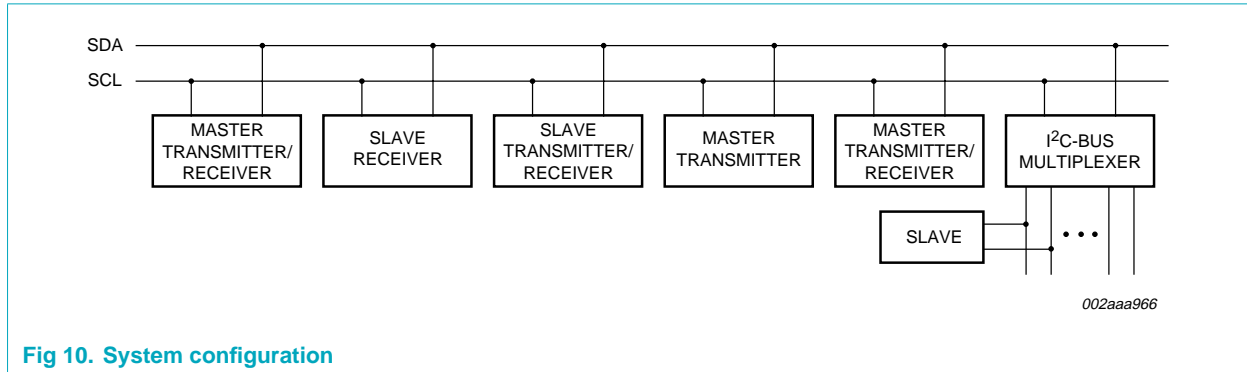

Fig 10. System configuration

7.3 Acknowledge

The number of data bytes transferred between the START and the STOP conditions from transmitter to receiver is not limited. Each byte of eight bits is followed by one acknowledge bit. The acknowledge bit is a HIGH level put on the bus by the transmitter, whereas the master generates an extra acknowledge related clock pulse.

A slave receiver which is addressed must generate an acknowledge after the reception of each byte. Also a master must generate an acknowledge after the reception of each byte that has been clocked out of the slave transmitter. The device that acknowledges has to pull down the SDA line during the acknowledge clock pulse, so that the SDA line is stable LOW during the HIGH period of the acknowledge related clock pulse; set-up and hold times must be taken into account.

A master receiver must signal an end of data to the transmitter by not generating an acknowledge on the last byte that has been clocked out of the slave. In this event, the transmitter must leave the data line HIGH to enable the master to generate a STOP condition.

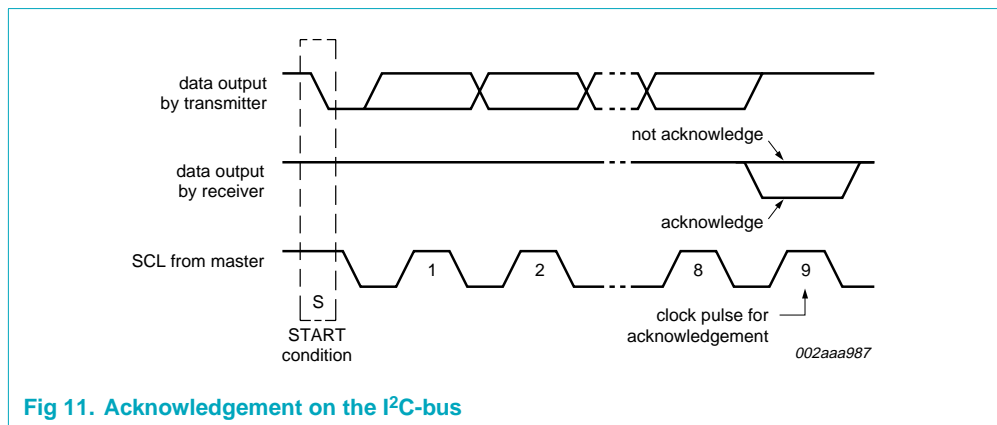
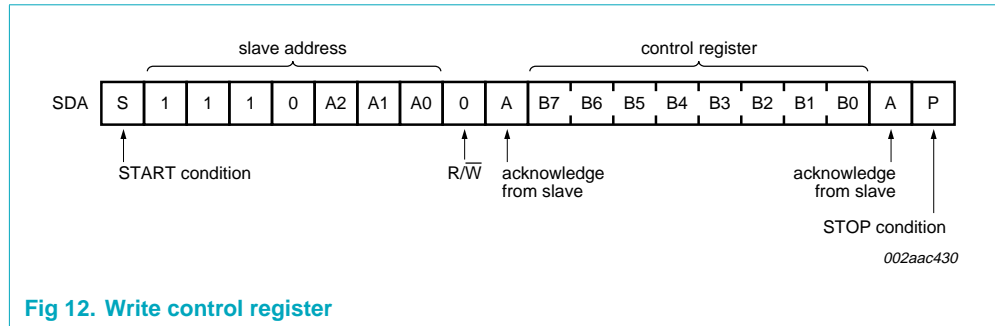

Fig 11. Acknowledgement on the I²C-bus

7.4 Bus transactions

Data is transmitted to the PCA9549 control register using the Write mode as shown in [Figure 12](#).



Data is read from the PCA9549 using the Read mode as shown in [Figure 13](#).

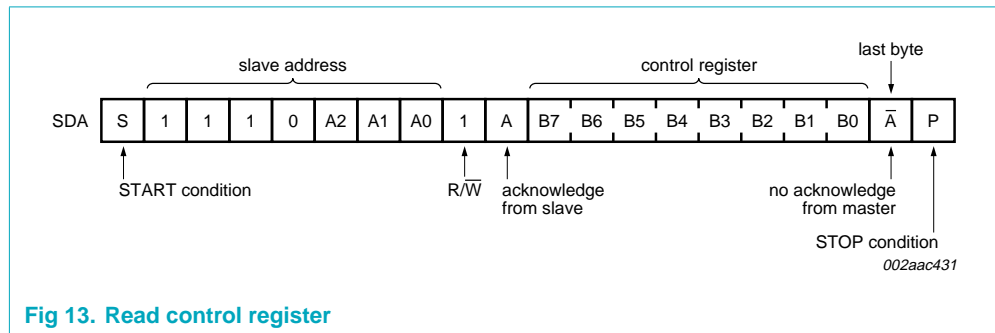

8. Limiting values

Table 5. Limiting values

In accordance with the Absolute Maximum Rating System (IEC 60134).^[1]

Symbol	Parameter	Conditions	Min	Max	Unit
V _{DD}	supply voltage		-0.5	+7.0	V
V _I	input voltage		-0.5	+7.0	V
I _I	input current		-20	+20	mA
I _O	output current		-25	+25	mA
I _{DD}	supply current		-100	+100	mA
I _{SS}	ground supply current		-100	+100	mA
P _{tot}	total power dissipation		-	400	mW
T _{stg}	storage temperature		-60	+150	°C
T _{amb}	ambient temperature	operating	-40	+85	°C

[1] The performance capability of a high-performance integrated circuit in conjunction with its thermal environment can create junction temperatures which are detrimental to reliability. The maximum junction temperature of this integrated circuit should not exceed 125 °C.

9. Static characteristics

Table 6. Static characteristics
 $V_{DD} = 2.3 \text{ V to } 3.6 \text{ V}; V_{SS} = 0 \text{ V}; T_{amb} = -40 \text{ }^\circ\text{C to } +85 \text{ }^\circ\text{C};$ unless otherwise specified.

 See [Table 7 on page 12](#) for $V_{DD} = 4.5 \text{ V to } 5.5 \text{ V}$ [1].

Symbol	Parameter	Conditions	Min	Typ	Max	Unit
Supply						
V_{DD}	supply voltage		2.3	-	3.6	V
I_{DD}	supply current	Operating mode; $V_{DD} = 3.6 \text{ V}$; no load; $V_I = V_{DD}$ or V_{SS} ; $f_{SCL} = 100 \text{ kHz}$	-	20	50	μA
I_{stb}	standby current	Standby mode; $V_{DD} = 3.6 \text{ V}$; no load; $V_I = V_{DD}$ or V_{SS}	-	0.1	1	μA
V_{POR}	power-on reset voltage	no load; $V_I = V_{DD}$ or V_{SS}	[2]	1.6	2.1	V
Input SCL; input/output SDA						
V_{IL}	LOW-level input voltage		-0.5	-	+0.3 V_{DD}	V
V_{IH}	HIGH-level input voltage		0.7 V_{DD}	-	6	V
I_{OL}	LOW-level output current	$V_{OL} = 0.4 \text{ V}$	3	-	-	mA
		$V_{OL} = 0.6 \text{ V}$	6	-	-	mA
I_L	leakage current	$V_I = V_{DD}$ or V_{SS}	-1	-	+1	μA
C_i	input capacitance	$V_I = V_{SS}$	-	6	21	pF
Select inputs A0 to A2, RESET						
V_{IL}	LOW-level input voltage		-0.5	-	+0.3 V_{DD}	V
V_{IH}	HIGH-level input voltage		0.7 V_{DD}	-	$V_{DD} + 0.5$	V
I_{LI}	input leakage current	pin at V_{DD} or V_{SS}	-1	-	+1	μA
C_i	input capacitance	$V_I = V_{SS}$	-	2	5	pF
Pass gate						
R_{on}	ON-state resistance	$V_{DD} = 3.0 \text{ V to } 3.6 \text{ V}; V_O = 0.4 \text{ V};$ $I_O = 15 \text{ mA}$	-	7	12	Ω
		$V_{DD} = 2.3 \text{ V to } 2.7 \text{ V}; V_O = 0.4 \text{ V};$ $I_O = 10 \text{ mA}$	-	8	15	Ω
$V_{O(sw)}$	switch output voltage	$V_{i(sw)} = V_{DD} = 3.3 \text{ V}; I_{O(sw)} = -100 \mu\text{A}$	-	1.9	-	V
		$V_{i(sw)} = V_{DD} = 3.0 \text{ V to } 3.6 \text{ V};$ $I_{O(sw)} = -100 \mu\text{A}$	1.6	-	2.8	V
		$V_{i(sw)} = V_{DD} = 2.5 \text{ V}; I_{O(sw)} = -100 \mu\text{A}$	-	1.5	-	V
		$V_{i(sw)} = V_{DD} = 2.3 \text{ V to } 2.7 \text{ V};$ $I_{O(sw)} = -100 \mu\text{A}$	1.0	-	2.0	V
I_L	leakage current	$V_I = V_{DD}$ or V_{SS}	-1	-	+1	μA
C_{io}	input/output capacitance	$V_I = V_{SS}$	-	3	5	pF

[1] For operation between published voltage ranges, refer to the worst-case parameters in both ranges.

[2] V_{DD} must be lowered to 0.2 V in order to reset part.

Table 7. Static characteristics

$V_{DD} = 4.5\text{ V to }5.5\text{ V}$; $V_{SS} = 0\text{ V}$; $T_{amb} = -40\text{ °C to }+85\text{ °C}$; unless otherwise specified.

See [Table 6 on page 11](#) for $V_{DD} = 2.3\text{ V to }3.6\text{ V}$ ^[1].

Symbol	Parameter	Conditions	Min	Typ	Max	Unit
Supply						
V_{DD}	supply voltage		4.5	-	5.5	V
I_{DD}	supply current	Operating mode; $V_{DD} = 5.5\text{ V}$; no load; $V_I = V_{DD}$ or V_{SS} ; $f_{SCL} = 100\text{ kHz}$	-	65	100	μA
I_{stb}	standby current	Standby mode; $V_{DD} = 5.5\text{ V}$; no load; $V_I = V_{DD}$ or V_{SS}	-	0.6	2	μA
V_{POR}	power-on reset voltage	no load; $V_I = V_{DD}$ or V_{SS}	[2]	1.7	2.1	V
Input SCL; input/output SDA						
V_{IL}	LOW-level input voltage		-0.5	-	+0.3 V_{DD}	V
V_{IH}	HIGH-level input voltage		0.7 V_{DD}	-	6	V
I_{OL}	LOW-level output current	$V_{OL} = 0.4\text{ V}$	3	-	-	mA
		$V_{OL} = 0.6\text{ V}$	6	-	-	mA
I_{IL}	LOW-level input current	$V_I = V_{SS}$	1	-	1	μA
I_{IH}	HIGH-level input current	$V_I = V_{SS}$	1	-	1	μA
C_i	input capacitance	$V_I = V_{SS}$	-	6	21	pF
Select inputs A[0:2]/RESET						
V_{IL}	LOW-level input voltage		-0.5	-	+0.3 V_{DD}	V
V_{IH}	HIGH-level input voltage		0.7 V_{DD}	-	$V_{DD} + 0.5$	V
I_{LI}	input leakage current	pin at V_{DD} or V_{SS}	-1	-	+50	μA
C_i	input capacitance	$V_I = V_{SS}$	-	2	5	pF
Pass gate						
R_{on}	ON-state resistance	$V_{DD} = 4.5\text{ V to }5.5\text{ V}$; $V_O = 0.4\text{ V}$; $I_O = 15\text{ mA}$	-	5	8	Ω
$V_{o(sw)}$	switch output voltage	$V_{i(sw)} = V_{DD} = 5.0\text{ V}$; $I_{o(sw)} = -100\text{ }\mu\text{A}$	-	3.6	-	V
		$V_{i(sw)} = V_{DD} = 4.5\text{ V to }5.5\text{ V}$; $I_{o(sw)} = -100\text{ }\mu\text{A}$	2.6	-	4.5	V
I_L	leakage current	$V_I = V_{DD}$ or V_{SS}	-10	-	+10	μA
C_{io}	input/output capacitance	$V_I = V_{SS}$	-	3	5	pF

[1] For operation between published voltage ranges, refer to the worst-case parameters in both ranges.

[2] V_{DD} must be lowered to 0.2 V in order to reset part.

10. Dynamic characteristics

Table 8. Dynamic characteristics

Symbol	Parameter	Conditions	Standard-mode I ² C-bus		Fast-mode I ² C-bus		Unit
			Min	Max	Min	Max	
t _{PD}	propagation delay	A to B; V _{DD} = 4.5 V to 5.5 V	-	0.25 ^[1]	-	0.25 ^[1]	ns
f _{SCL}	SCL clock frequency		0	100	0	400	kHz
t _{BUF}	bus free time between a STOP and START condition		4.7	-	1.3	-	μs
t _{HD;STA}	hold time (repeated) START condition		^[2] 4.0	-	0.6	-	μs
t _{LOW}	LOW period of the SCL clock		4.7	-	1.3	-	μs
t _{HIGH}	HIGH period of the SCL clock		4.0	-	0.6	-	μs
t _{SU;STA}	set-up time for a repeated START condition		4.7	-	0.6	-	μs
t _{SU;STO}	set-up time for STOP condition		4.0	-	0.6	-	μs
t _{HD;DAT}	data hold time		0 ^[3]	3.45	0 ^[3]	0.9	μs
t _{SU;DAT}	data set-up time		250	-	100	-	ns
t _r	rise time of both SDA and SCL signals		-	1000	20 + 0.1C _b ^[4]	300	ns
t _f	fall time of both SDA and SCL signals		-	300	20 + 0.1C _b ^[4]	300	μs
C _b	capacitive load for each bus line		-	400	-	400	μs
t _{SP}	pulse width of spikes that must be suppressed by the input filter		-	50	-	50	ns
t _{VD;DAT}	data valid time	HIGH-to-LOW	-	1	-	1	μs
		LOW-to-HIGH	-	0.6	-	0.6	μs
t _{VD;ACK}	data valid acknowledge time		-	1	-	1	μs
RESET							
t _{w(rst)L}	LOW-level reset time		4	-	4	-	ns
t _{rst}	reset time	SDA clear	500	-	500	-	ns
t _{REC;STA}	recovery time to START condition		0	-	0	-	ns

[1] Pass gate propagation delay is calculated from the 6 Ω typical R_{on} and the 50 pF load capacitance.

[2] After this period, the first clock pulse is generated.

[3] A device must internally provide a hold time of at least 300 ns for the SDA signal (referred to the V_{IH(min)} of the SCL signal) in order to bridge the undefined region of the falling edge of SCL.

[4] C_b = total capacitance of one bus line in pF.

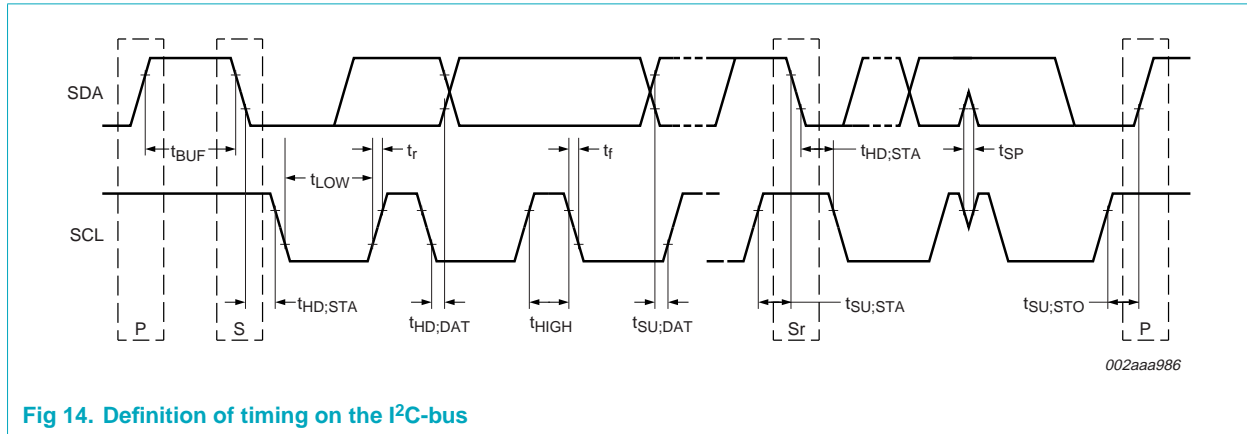

Fig 14. Definition of timing on the I²C-bus

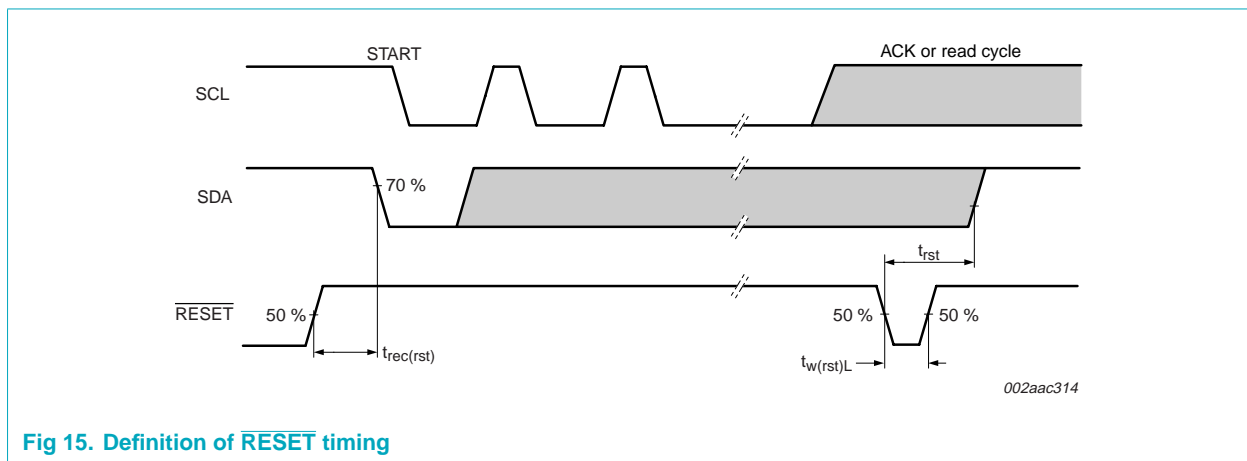
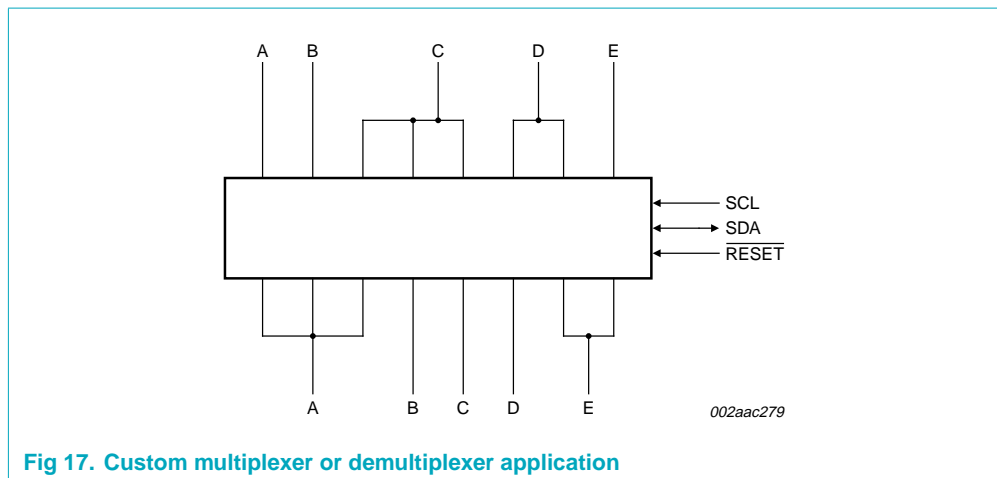
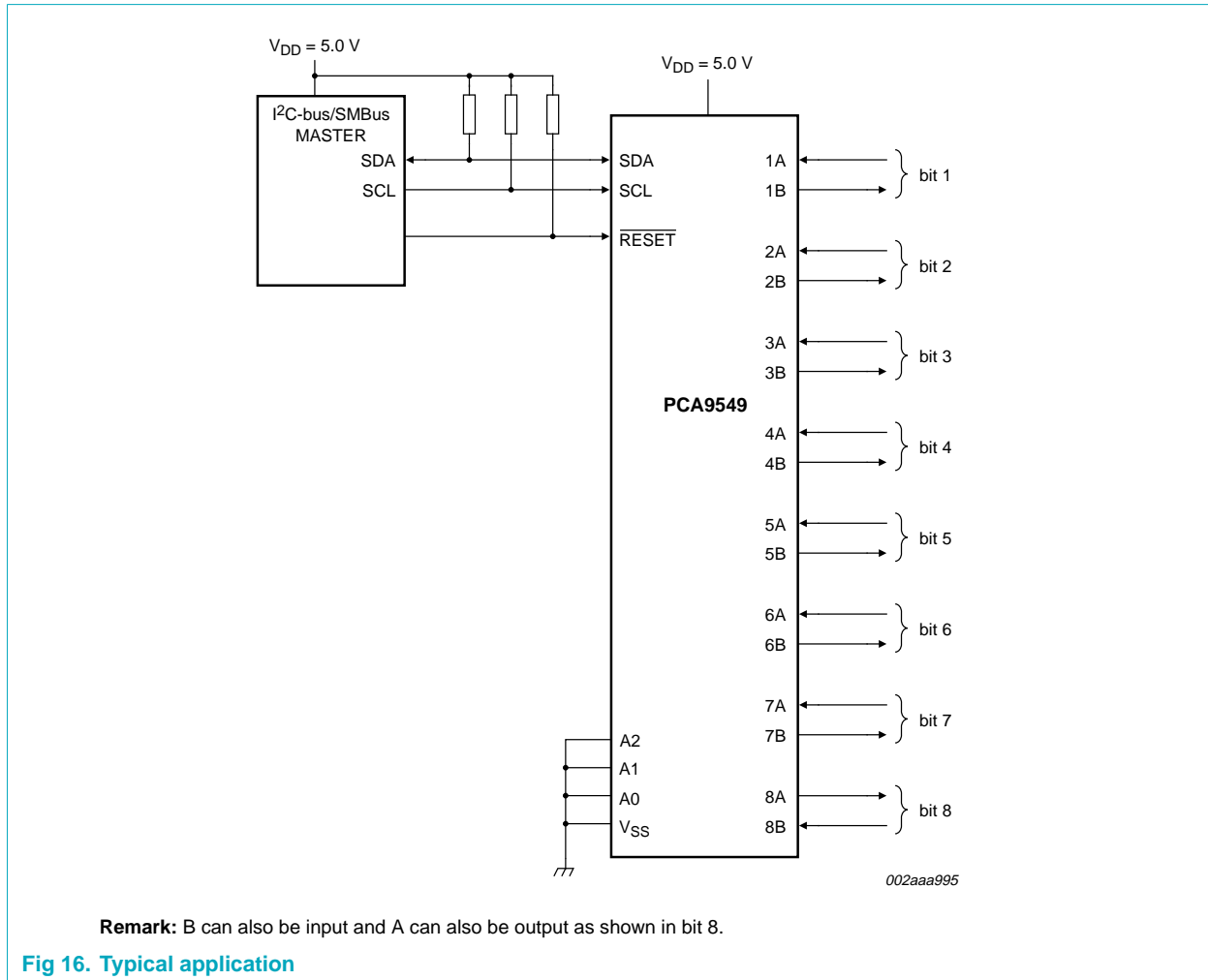
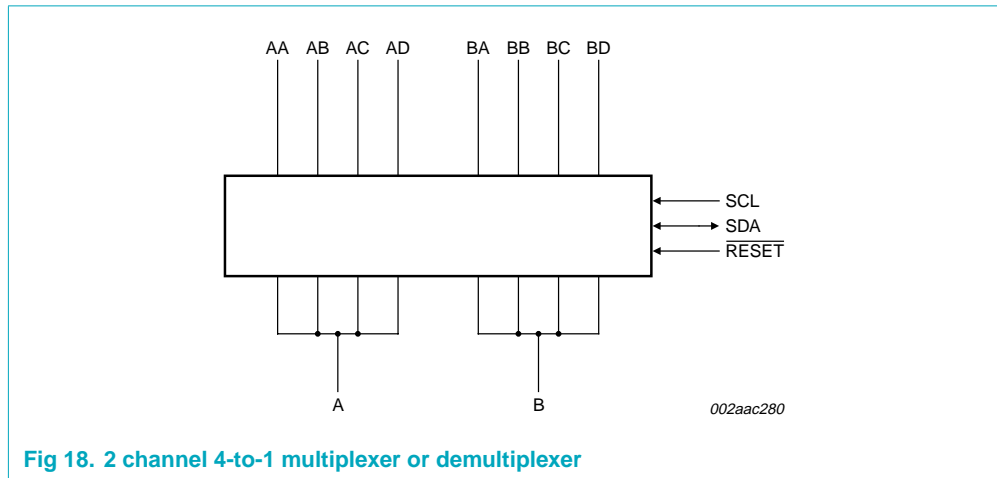

Fig 15. Definition of RESET timing

11. Application information





12. Test information

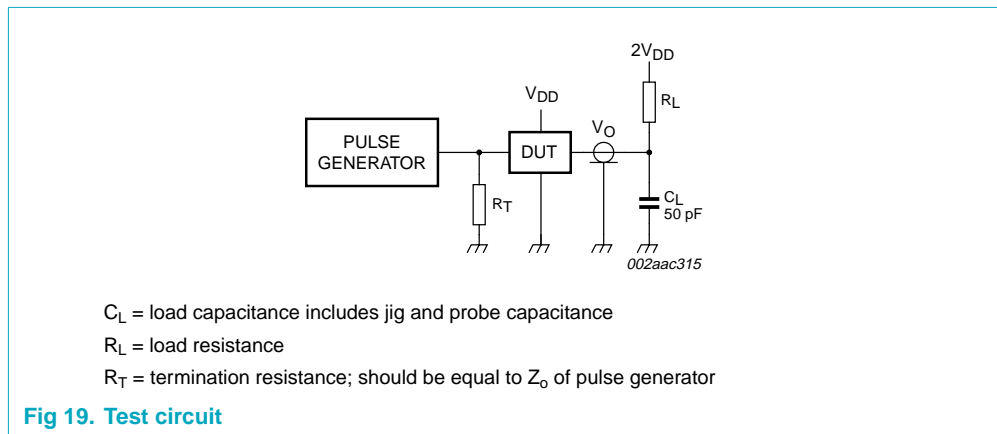

13. Package outline

SO24: plastic small outline package; 24 leads; body width 7.5 mm

SOT137-1

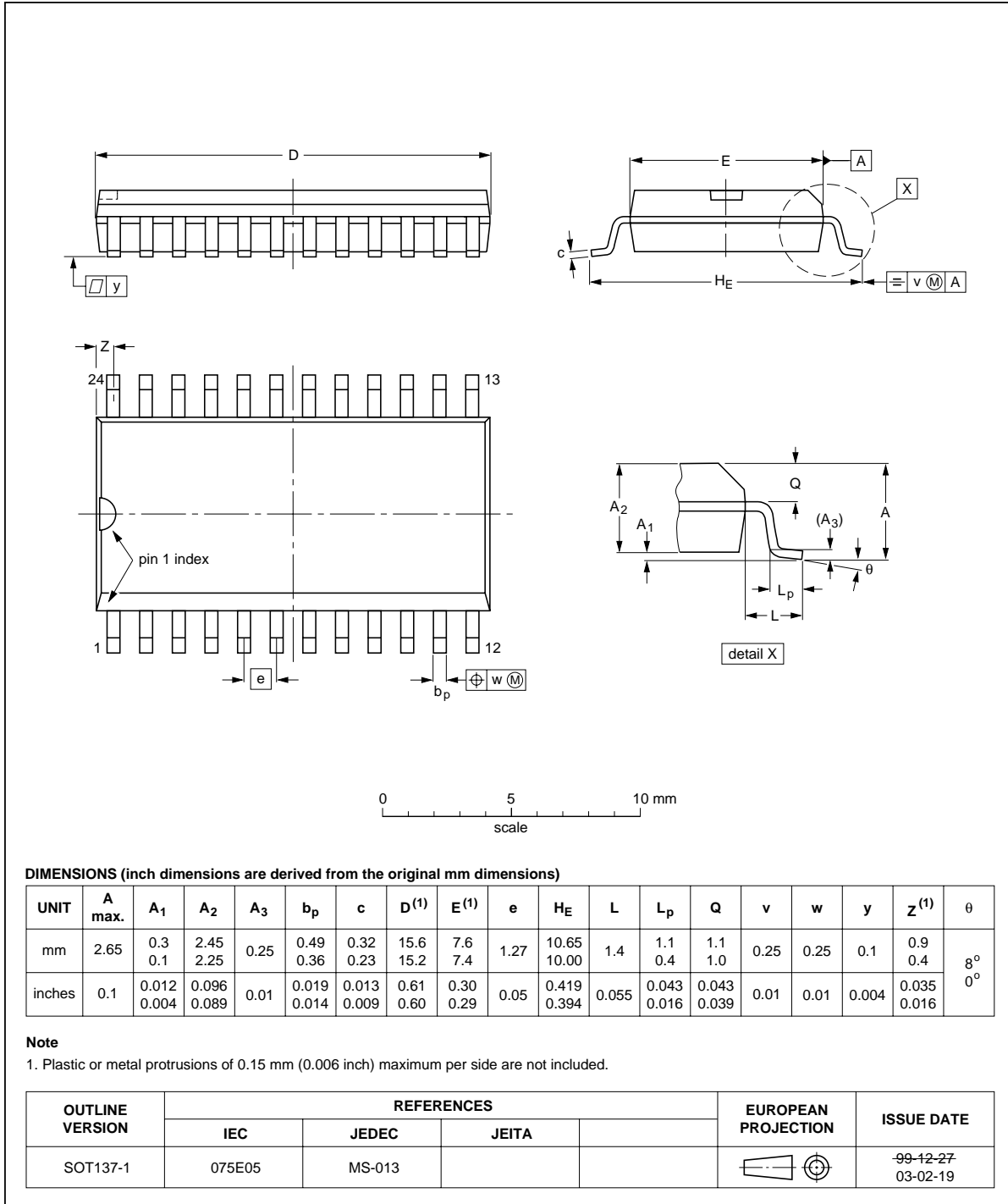

Fig 20. SO24 package outline (SOT137-1)

TSSOP24: plastic thin shrink small outline package; 24 leads; body width 4.4 mm

SOT355-1

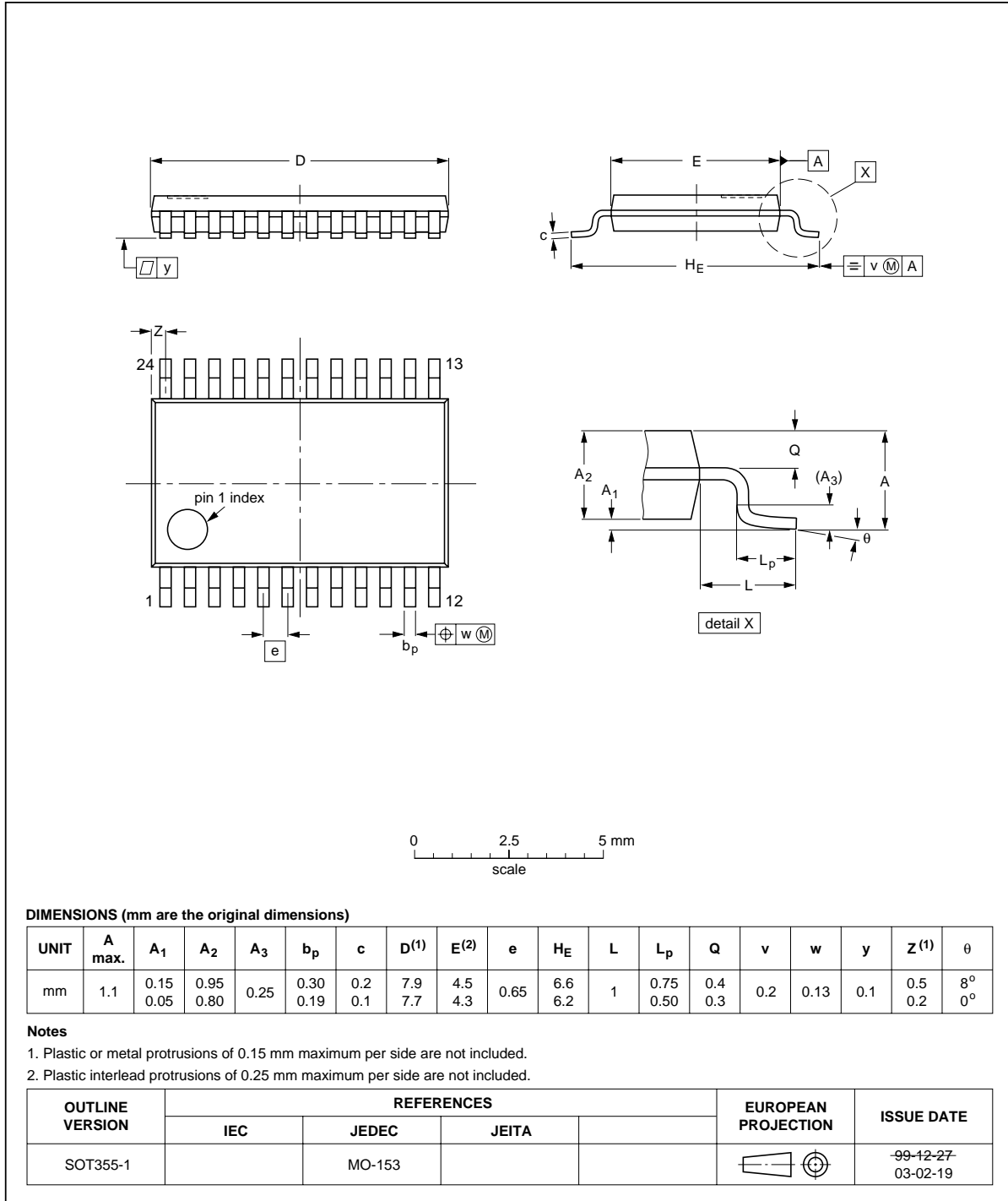

Fig 21. TSSOP24 package outline (SOT355-1)

HVQFN24: plastic thermal enhanced very thin quad flat package; no leads; 24 terminals; body 4 x 4 x 0.85 mm

SOT616-1

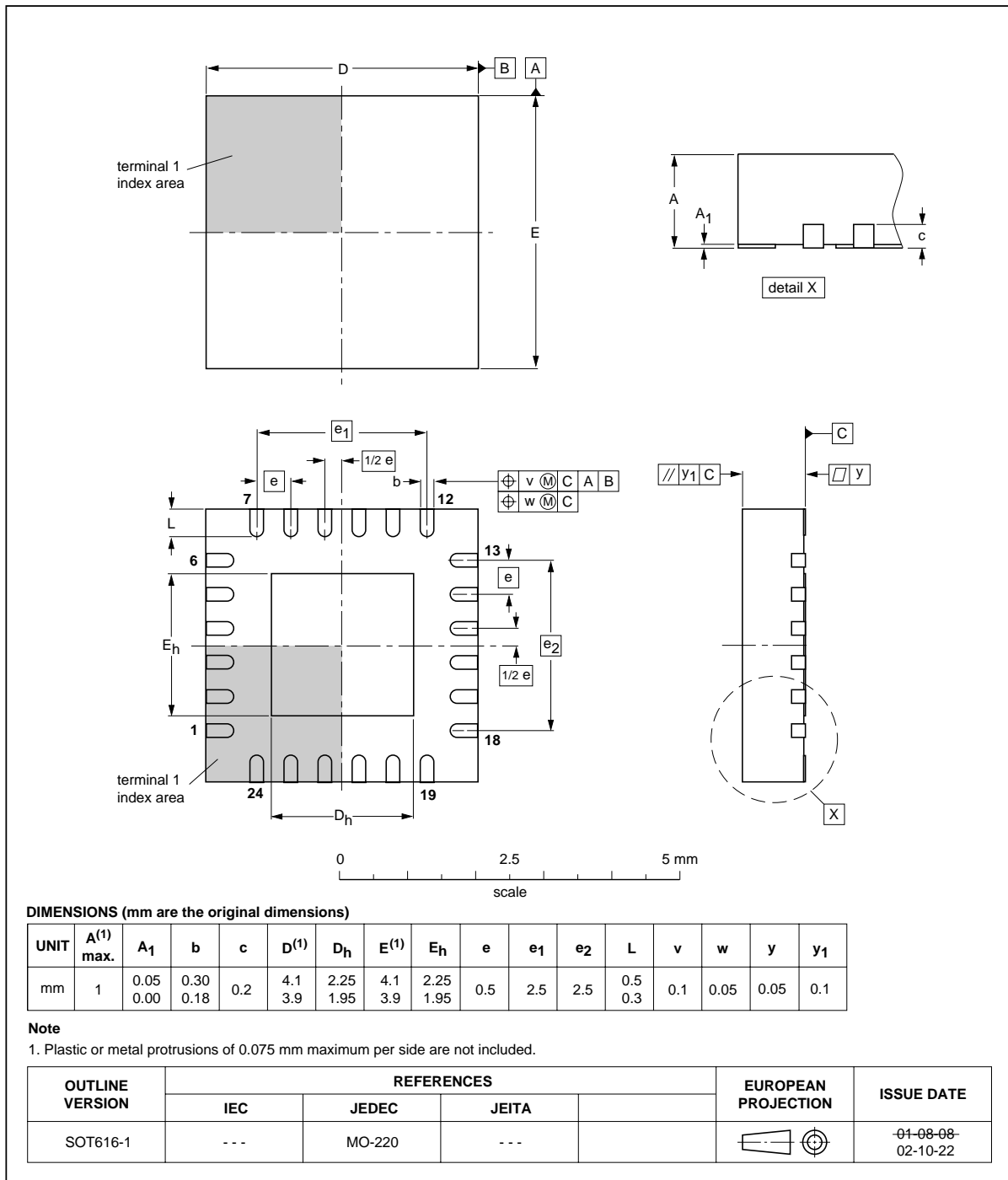

Fig 22. HVQFN24 package outline (SOT616-1)

14. Soldering

14.1 Introduction to soldering surface mount packages

There is no soldering method that is ideal for all surface mount IC packages. Wave soldering can still be used for certain surface mount ICs, but it is not suitable for fine pitch SMDs. In these situations reflow soldering is recommended.

14.2 Reflow soldering

Reflow soldering requires solder paste (a suspension of fine solder particles, flux and binding agent) to be applied to the printed-circuit board by screen printing, stencilling or pressure-syringe dispensing before package placement. Driven by legislation and environmental forces the worldwide use of lead-free solder pastes is increasing.

Several methods exist for reflowing; for example, convection or convection/infrared heating in a conveyor type oven. Throughput times (preheating, soldering and cooling) vary between 100 seconds and 200 seconds depending on heating method.

Typical reflow temperatures range from 215 °C to 260 °C depending on solder paste material. The peak top-surface temperature of the packages should be kept below:

Table 9. SnPb eutectic process - package peak reflow temperatures (from J-STD-020C July 2004)

Package thickness	Volume mm ³ < 350	Volume mm ³ ≥ 350
< 2.5 mm	240 °C + 0/-5 °C	225 °C + 0/-5 °C
≥ 2.5 mm	225 °C + 0/-5 °C	225 °C + 0/-5 °C

Table 10. Pb-free process - package peak reflow temperatures (from J-STD-020C July 2004)

Package thickness	Volume mm ³ < 350	Volume mm ³ 350 to 2000	Volume mm ³ > 2000
< 1.6 mm	260 °C + 0 °C	260 °C + 0 °C	260 °C + 0 °C
1.6 mm to 2.5 mm	260 °C + 0 °C	250 °C + 0 °C	245 °C + 0 °C
≥ 2.5 mm	250 °C + 0 °C	245 °C + 0 °C	245 °C + 0 °C

Moisture sensitivity precautions, as indicated on packing, must be respected at all times.

14.3 Wave soldering

Conventional single wave soldering is not recommended for surface mount devices (SMDs) or printed-circuit boards with a high component density, as solder bridging and non-wetting can present major problems.

To overcome these problems the double-wave soldering method was specifically developed.

If wave soldering is used the following conditions must be observed for optimal results:

- Use a double-wave soldering method comprising a turbulent wave with high upward pressure followed by a smooth laminar wave.
- For packages with leads on two sides and a pitch (e):

Octal bus switch with individually I²C-bus controlled enables

- larger than or equal to 1.27 mm, the footprint longitudinal axis is **preferred** to be parallel to the transport direction of the printed-circuit board;
- smaller than 1.27 mm, the footprint longitudinal axis **must** be parallel to the transport direction of the printed-circuit board.

The footprint must incorporate solder thieves at the downstream end.

- For packages with leads on four sides, the footprint must be placed at a 45° angle to the transport direction of the printed-circuit board. The footprint must incorporate solder thieves downstream and at the side corners.

During placement and before soldering, the package must be fixed with a droplet of adhesive. The adhesive can be applied by screen printing, pin transfer or syringe dispensing. The package can be soldered after the adhesive is cured.

Typical dwell time of the leads in the wave ranges from 3 seconds to 4 seconds at 250 °C or 265 °C, depending on solder material applied, SnPb or Pb-free respectively.

A mildly-activated flux will eliminate the need for removal of corrosive residues in most applications.

14.4 Manual soldering

Fix the component by first soldering two diagonally-opposite end leads. Use a low voltage (24 V or less) soldering iron applied to the flat part of the lead. Contact time must be limited to 10 seconds at up to 300 °C.

When using a dedicated tool, all other leads can be soldered in one operation within 2 seconds to 5 seconds between 270 °C and 320 °C.

14.5 Package related soldering information

Table 11. Suitability of surface mount IC packages for wave and reflow soldering methods

Package ^[1]	Soldering method	
	Wave	Reflow ^[2]
BGA, HTSSON..T ^[3] , LBGA, LFBGA, SQFP, SSOP..T ^[3] , TFBGA, VFBGA, XSON	not suitable	suitable
DHVQFN, HBCC, HBGA, HLQFP, HSO, HSOP, HSQFP, HSSON, HTQFP, HTSSOP, HVQFN, HVSON, SMS	not suitable ^[4]	suitable
PLCC ^[5] , SO, SOJ	suitable	suitable
LQFP, QFP, TQFP	not recommended ^{[5][6]}	suitable
SSOP, TSSOP, VSO, VSSOP	not recommended ^[7]	suitable
CWQCCN..L ^[8] , PMFP ^[9] , WQCCN..L ^[8]	not suitable	not suitable

[1] For more detailed information on the BGA packages refer to the *(LF)BGA Application Note (AN01026)*; order a copy from your Philips Semiconductors sales office.

[2] All surface mount (SMD) packages are moisture sensitive. Depending upon the moisture content, the maximum temperature (with respect to time) and body size of the package, there is a risk that internal or external package cracks may occur due to vaporization of the moisture in them (the so called popcorn effect). For details, refer to the Drypack information in the *Data Handbook IC26; Integrated Circuit Packages; Section: Packing Methods*.

- [3] These transparent plastic packages are extremely sensitive to reflow soldering conditions and must on no account be processed through more than one soldering cycle or subjected to infrared reflow soldering with peak temperature exceeding $217\text{ °C} \pm 10\text{ °C}$ measured in the atmosphere of the reflow oven. The package body peak temperature must be kept as low as possible.
- [4] These packages are not suitable for wave soldering. On versions with the heatsink on the bottom side, the solder cannot penetrate between the printed-circuit board and the heatsink. On versions with the heatsink on the top side, the solder might be deposited on the heatsink surface.
- [5] If wave soldering is considered, then the package must be placed at a 45° angle to the solder wave direction. The package footprint must incorporate solder thieves downstream and at the side corners.
- [6] Wave soldering is suitable for LQFP, QFP and TQFP packages with a pitch (e) larger than 0.8 mm; it is definitely not suitable for packages with a pitch (e) equal to or smaller than 0.65 mm.
- [7] Wave soldering is suitable for SSOP, TSSOP, VSO and VSSOP packages with a pitch (e) equal to or larger than 0.65 mm; it is definitely not suitable for packages with a pitch (e) equal to or smaller than 0.5 mm.
- [8] Image sensor packages in principle should not be soldered. They are mounted in sockets or delivered pre-mounted on flex foil. However, the image sensor package can be mounted by the client on a flex foil by using a hot bar soldering process. The appropriate soldering profile can be provided on request.
- [9] Hot bar soldering or manual soldering is suitable for PMFP packages.

15. Abbreviations

Table 12. Abbreviations

Acronym	Description
CBT	Cross Bar Technology
CDM	Charged Device Model
DUT	Device Under Test
ESD	ElectroStatic Discharge
HBM	Human Body Model
I ² C	Inter Integrated Circuit
MM	Machine Model
PCB	Printed-Circuit Board
SMBus	System Management Bus
TTL	Transistor-Transistor Logic

16. Revision history

Table 13. Revision history

Document ID	Release date	Data sheet status	Change notice	Supersedes
PCA9549_1	20060711	Product data sheet	-	-

17. Legal information

17.1 Data sheet status

Document status ^{[1][2]}	Product status ^[3]	Definition
Objective [short] data sheet	Development	This document contains data from the objective specification for product development.
Preliminary [short] data sheet	Qualification	This document contains data from the preliminary specification.
Product [short] data sheet	Production	This document contains the product specification.

[1] Please consult the most recently issued document before initiating or completing a design.

[2] The term 'short data sheet' is explained in section "Definitions".

[3] The product status of device(s) described in this document may have changed since this document was published and may differ in case of multiple devices. The latest product status information is available on the Internet at URL <http://www.semiconductors.philips.com>.

17.2 Definitions

Draft — The document is a draft version only. The content is still under internal review and subject to formal approval, which may result in modifications or additions. Philips Semiconductors does not give any representations or warranties as to the accuracy or completeness of information included herein and shall have no liability for the consequences of use of such information.

Short data sheet — A short data sheet is an extract from a full data sheet with the same product type number(s) and title. A short data sheet is intended for quick reference only and should not be relied upon to contain detailed and full information. For detailed and full information see the relevant full data sheet, which is available on request via the local Philips Semiconductors sales office. In case of any inconsistency or conflict with the short data sheet, the full data sheet shall prevail.

17.3 Disclaimers

General — Information in this document is believed to be accurate and reliable. However, Philips Semiconductors does not give any representations or warranties, expressed or implied, as to the accuracy or completeness of such information and shall have no liability for the consequences of use of such information.

Right to make changes — Philips Semiconductors reserves the right to make changes to information published in this document, including without limitation specifications and product descriptions, at any time and without notice. This document supersedes and replaces all information supplied prior to the publication hereof.

Suitability for use — Philips Semiconductors products are not designed, authorized or warranted to be suitable for use in medical, military, aircraft, space or life support equipment, nor in applications where failure or malfunction of a Philips Semiconductors product can reasonably be expected

to result in personal injury, death or severe property or environmental damage. Philips Semiconductors accepts no liability for inclusion and/or use of Philips Semiconductors products in such equipment or applications and therefore such inclusion and/or use is at the customer's own risk.

Applications — Applications that are described herein for any of these products are for illustrative purposes only. Philips Semiconductors makes no representation or warranty that such applications will be suitable for the specified use without further testing or modification.

Limiting values — Stress above one or more limiting values (as defined in the Absolute Maximum Ratings System of IEC 60134) may cause permanent damage to the device. Limiting values are stress ratings only and operation of the device at these or any other conditions above those given in the Characteristics sections of this document is not implied. Exposure to limiting values for extended periods may affect device reliability.

Terms and conditions of sale — Philips Semiconductors products are sold subject to the general terms and conditions of commercial sale, as published at <http://www.semiconductors.philips.com/profile/terms>, including those pertaining to warranty, intellectual property rights infringement and limitation of liability, unless explicitly otherwise agreed to in writing by Philips Semiconductors. In case of any inconsistency or conflict between information in this document and such terms and conditions, the latter will prevail.

No offer to sell or license — Nothing in this document may be interpreted or construed as an offer to sell products that is open for acceptance or the grant, conveyance or implication of any license under any copyrights, patents or other industrial or intellectual property rights.

17.4 Trademarks

Notice: All referenced brands, product names, service names and trademarks are the property of their respective owners.

I²C-bus — logo is a trademark of Koninklijke Philips Electronics N.V.

18. Contact information

For additional information, please visit: <http://www.semiconductors.philips.com>

For sales office addresses, send an email to: sales.addresses@www.semiconductors.philips.com

19. Contents

1	General description	1
2	Features	1
3	Ordering information	2
3.1	Ordering options	2
4	Block diagram	2
5	Pinning information	3
5.1	Pinning	3
5.2	Pin description	4
6	Functional description	5
6.1	Device addressing	5
6.2	Control register	5
6.2.1	Control register definition	5
6.3	RESET input	6
6.4	Power-on reset	6
6.5	CBT characteristic over V _{DD} range	6
7	Characteristics of the I²C-bus	8
7.1	Bit transfer	8
7.1.1	START and STOP conditions	8
7.2	System configuration	8
7.3	Acknowledge	9
7.4	Bus transactions	10
8	Limiting values	10
9	Static characteristics	11
10	Dynamic characteristics	13
11	Application information	15
12	Test information	16
13	Package outline	17
14	Soldering	20
14.1	Introduction to soldering surface mount packages	20
14.2	Reflow soldering	20
14.3	Wave soldering	20
14.4	Manual soldering	21
14.5	Package related soldering information	21
15	Abbreviations	22
16	Revision history	22
17	Legal information	23
17.1	Data sheet status	23
17.2	Definitions	23
17.3	Disclaimers	23
17.4	Trademarks	23
18	Contact information	23
19	Contents	24

Please be aware that important notices concerning this document and the product(s) described herein, have been included in section 'Legal information'.



© Koninklijke Philips Electronics N.V. 2006. All rights reserved.

For more information, please visit: <http://www.semiconductors.philips.com>.
For sales office addresses, email to: sales.addresses@www.semiconductors.philips.com.

Date of release: 11 July 2006

Document identifier: PCA9549_1