

# 0.5mm Pitch Board to Board Connector

## DF17 Series

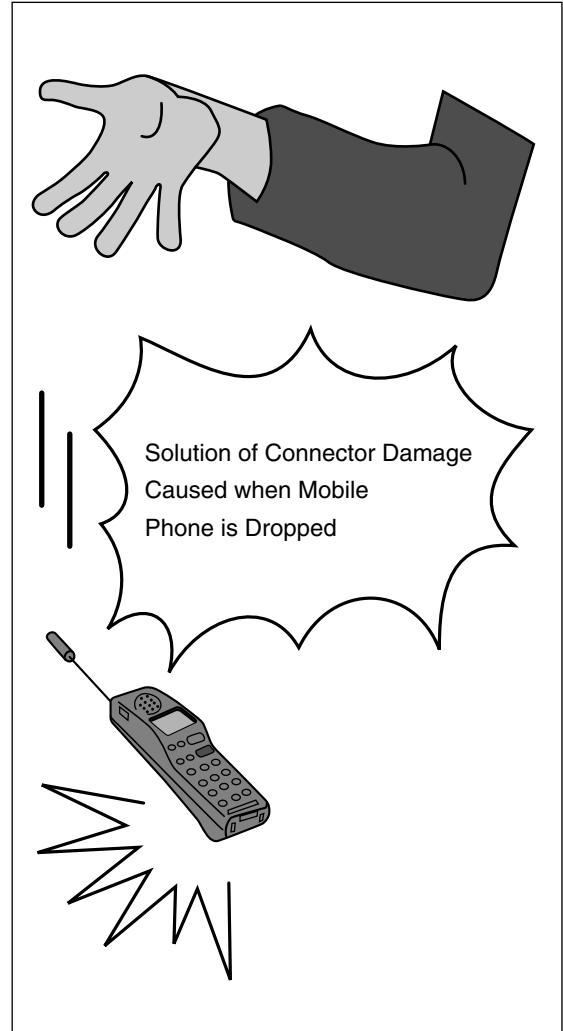
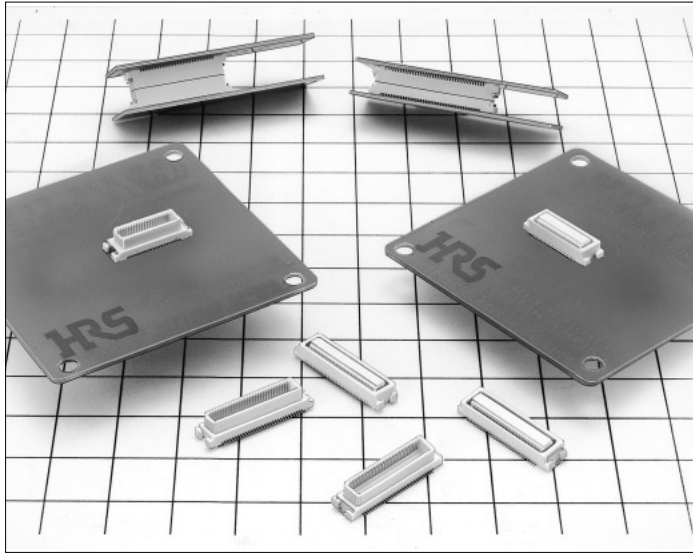

### ■ Features

1. DF17 series are the connector which has been developed mainly for the mobile phone.

Connector Problems Involving in Mobile phone  
Example:

The following problems can be solved;

"Connector Damage Caused when Mobile phone is Dropped"

"Electrical Discontinuity in Printed Circuit Board is Fixed (Fastened by screws)"

Especially, in regard to the resistance to the drop shock, Hirose has developed a new connector structure utilizing its unique technology, and greatly enhanced the resistance to the drop shock.

In broad variation development, the connector can be utilized in wide fields of LCD equipment, miniature information terminal equipment and so on, in addition to mobile phones.

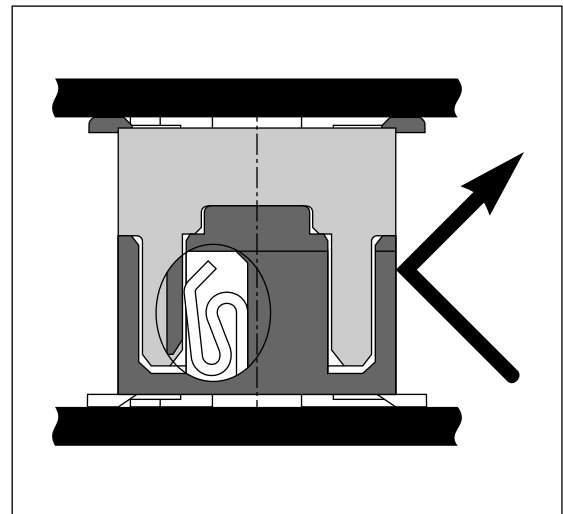

## 2. Performance Enhancement

The receptacle is designed in a BOX structure and has also enhanced shock-proof, pinch-proof and scoop-proof performance.

In addition, the receptacle contact has employed the high scoop-proof bellows type.

## 3. With Metal Fitting available

In order to grade up the strength against the mechanical stress, the metal fitting specification is also available.

## 4. Broad Variations in Contact Number

The connectors are lined up per 10 contacts between 20 and 80 contacts to take countermeasures for multi-signalization.

## 5. Stacking Height 4 to 8mm

The stacking height can be selected (per millimeter) between 4mm and 8mm in combination of the receptacle with the header.

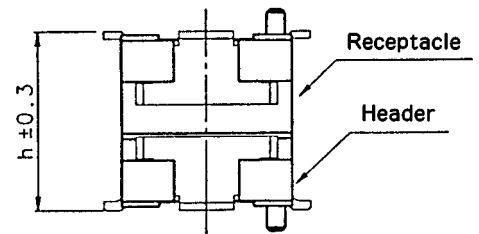
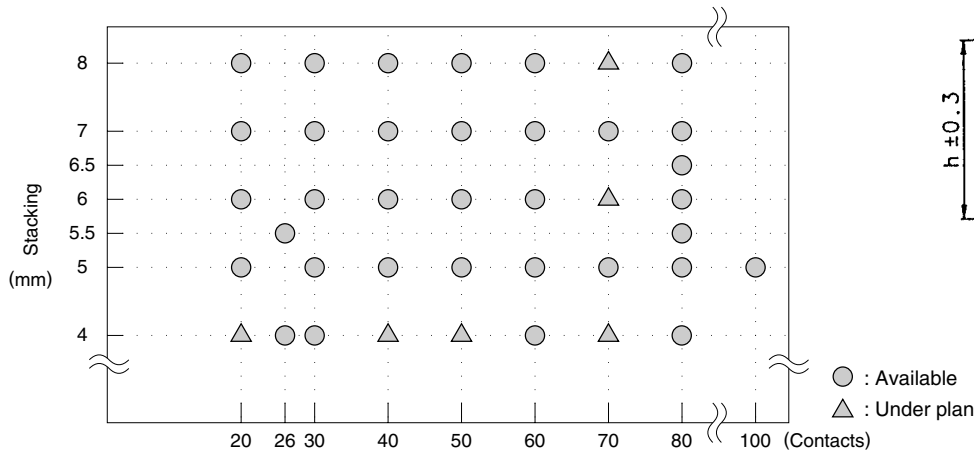
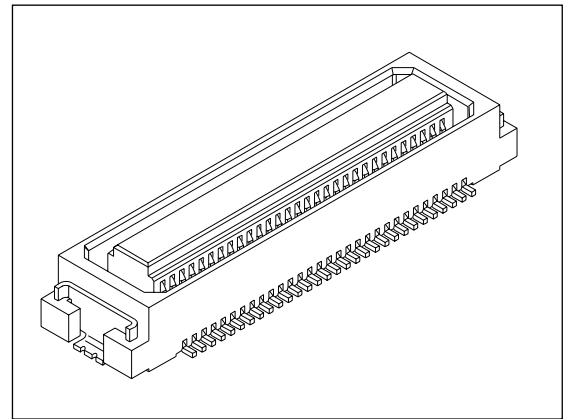

Header	Receptacle	DF17#(□)-*DS-0.5V	
		3.0	4.0
DF17#(□)-*DP-0.5V	2.0	5mm	6mm
	2.5	5.5mm	6.5mm
	4.0	7mm	8mm

Receptacle	DF17(3.0H)-*DS-0.5V
Header	DF17(1.0H)-*DP-0.5V
	4mm

Note : The stacking height doesn't include the solder paste thickness.

## ■ Applications

Mobile phones, LCD, miniature equipment and so on

## ■Product Specifications

Rating	Current rating Voltage rating	0.3A 50V AC	Operating Temperature Range Operating Humidity Range	-35 to 85°C (Note 1) 40 to 80%	Storage Temperature Range Storage Humidity Range	-10 to 60°C(Note 2) 40 to 70%
--------	----------------------------------	----------------	---	-----------------------------------	---	----------------------------------

Item	Specification	Condition
1. Insulation Resistance	500M ohms min.	100V DC
2. Withstanding voltage	No flashover or insulation breakdown.	150V AC/1 minute
3. Contact Resistance	60m ohms max.	100mA
4. Vibration	No electrical discontinuity of 1μs or more	Frequency: 10 to 55 Hz, single amplitude of 0.75 mm, 2 hours in each of the 3 directions.
5. Humidity (Steady state)	Contact resistance: 60m ohms max Insulation resistance:250M ohms min	96 hours at temperature of 40°C and humidity of 90% to 95%
6. Temperature Cycle	Contact resistance: 60m ohms max:Insulation resistance: 500M ohms min	(-55°C: 30 minutes 5 to 35°C: 10 minutes 85°C: 30 minutes 5 to 35°C: 10 minutes) 5 cycles
7. Durability (Mating/un-mating)	Contact resistance: 60m ohms	50 cycles
8. Resistance to Soldering heat	No deformation of components affecting performance.	Reflow: At the recommended temperature profile Manual soldering: 300°C for 3 seconds

Note 1: Includes temperature rise caused by current flow.

Note 2: The term "storage" refers to products stored for long period of time prior to mounting and use. Operating Temperature Range and Humidity range covers non conducting condition of installed connectors in storage, shipment or during transportation.

## ■Material

Product	Part	Material	Finish	Remarks
Receptacle	Insulator	Polyamide	White	UL94V-0
	Contact	Phosphor copper	Gold plated (Note 1)	———
	Metal Fitting	Phosphor copper	Tin-lead plated	———
Header	Insulator	Polyamide	White	UL94V-0
	Contact	Phosphor copper	Gold plated (Note 2)	———
	Metal Fitting	Phosphor copper	Tin-lead plated	———

Note1: DF17(0.3)-\*DS-0.5V : Contact area: gold plating/lead area: flash gold plated

DF17(4.0)-\*DS-0.5V : Contact area: gold plating/lead area: tin-lead plated

DF17(4.0)-\*DP-0.5V : Contact area: gold plating/lead area: tin-lead plated

Note2: The header gold plated product:Contact area: gold plating/lead area: tin-lead plated

DF17(1.0H)-\*DS-0.5V only: Contact area: gold plating/lead area: flash gold plated

## ◆Ordering Information

### ●Receptacle/Header

**DF17** **#** **(\*\*)** - **\* DS - 0.5 V (\*\*)**  

①
②
③
④
⑤
⑥
⑦
⑧

<b>①</b> Series Name: DF17 <b>②</b> Type <table border="1" style="margin-left: 20px;"> <thead> <tr> <th></th> <th>Fitting</th> <th>Boss</th> </tr> </thead> <tbody> <tr> <td>DF17</td> <td style="text-align: center;">○</td> <td style="text-align: center;">○</td> </tr> <tr> <td>DF17A</td> <td style="text-align: center;">×</td> <td style="text-align: center;">○</td> </tr> <tr> <td>DF17B</td> <td style="text-align: center;">○</td> <td style="text-align: center;">×</td> </tr> <tr> <td>DF17C</td> <td style="text-align: center;">×</td> <td style="text-align: center;">×</td> </tr> </tbody> </table>		Fitting	Boss	DF17	○	○	DF17A	×	○	DF17B	○	×	DF17C	×	×	<b>④</b> Number of Contacts 20,26,30,40,50,6,70,80contacts <b>⑤</b> Connector Type DS: Receptacle DP: Header <b>⑥</b> Contact Pitch: 0.5mm <b>⑦</b> Contact Type V: Straight SMT <b>⑧</b> Packaging Type (50): Gold plated, embossed tape packaging (51): Gold plated, tube packaging
	Fitting	Boss														
DF17	○	○														
DF17A	×	○														
DF17B	○	×														
DF17C	×	×														
<b>③</b> Product height The stacking height can be determined by adding the figures in parentheses to receptacle and header.																

## ■ Receptacle With metal fitting

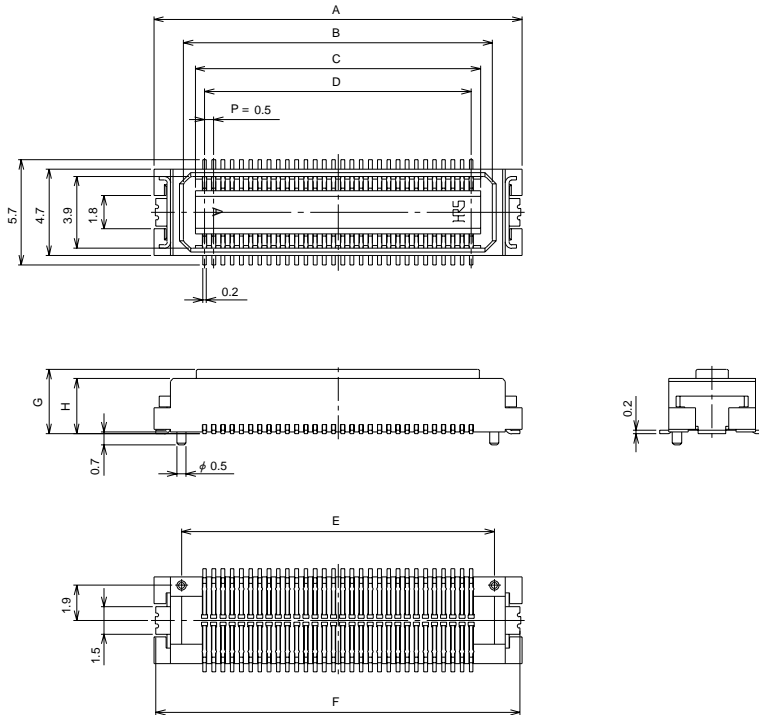

### ● Stacking Height: 4mm

Part Number	CL No.	Number of Contacts	A	B	C	D	E	F	G	H
DF17(3.0H)-26DS-0.5V(51)	683-0253-2-51	26	11.5	8.3	7.0	6.0	8.5	11.3	3.0	3.0
DF17(3.0H)-30DS-0.5V(51)	683-0268-0-51	30	12.5	9.3	8.0	7.0	9.5	12.3		
DF17(3.0H)-60DS-0.5V(51)	683-0361-5-51	60	20.0	16.8	15.5	14.5	17.0	19.8		

### ● Stacking Height: 5mm, 7mm

Part Number	CL No.	Number of Contacts	A	B	C	D	E	F	G	H
DF17(3.0)-20DS-0.5V(51)	683-0002-2-51	20	10.0	6.8	5.5	4.5	7.0	9.8	3.5	3.0
DF17(3.0)-26DS-0.5V(51)	683-0241-3-51	26	11.5	8.3	7.0	6.0	8.5	11.3		
DF17(3.0)-30DS-0.5V(51)	683-0003-5-51	30	12.5	9.3	8.0	7.0	9.5	12.3		
DF17(3.0)-40DS-0.5V(51)	683-0004-8-51	40	15.0	11.8	10.5	9.5	12.0	14.8		
DF17(3.0)-50DS-0.5V(51)	683-0005-0-51	50	17.5	14.3	13.0	12.0	14.5	17.3		
DF17(3.0)-60DS-0.5V(51)	683-0006-3-51	60	20.0	16.8	15.5	14.5	17.0	19.8		
DF17(3.0)-70DS-0.5V(51)	683-0007-6-51	70	22.5	19.3	18.0	17.0	19.5	22.3		
DF17(3.0)-80DS-0.5V(51)	683-0008-9-51	80	25.0	21.8	20.5	19.5	22.0	24.8		

### ● Stacking Height: 6mm, 8mm

Part Number	CL No.	Number of Contacts	A	B	C	D	E	F	G	H
DF17(4.0)-20DS-0.5V(51)	683-0042-7-51	20	10.0	6.8	5.5	4.5	7.0	9.8	4.5	4.0
DF17(4.0)-30DS-0.5V(51)	683-0043-0-51	30	12.5	9.3	8.0	7.0	9.5	12.3		
DF17(4.0)-40DS-0.5V(51)	683-0044-2-51	40	15.0	11.8	10.5	9.5	12.0	14.8		
DF17(4.0)-50DS-0.5V(51)	683-0045-5-51	50	17.5	14.3	13.0	12.0	14.5	17.3		
DF17(4.0)-60DS-0.5V(51)	683-0046-8-51	60	20.0	16.8	15.5	14.5	17.0	19.8		
DF17(4.0)-70DS-0.5V(51)	683-0047-0-51	70	22.5	19.3	18.0	17.0	19.5	22.3		
DF17(4.0)-80DS-0.5V(51)	683-0048-3-51	80	25.0	21.8	20.5	19.5	22.0	24.8		

Note 1. In regard to this product, the embossed tape packaging is the standard packaging. (1000 pcs./ reel.)

If the (50) tube packaging is required, please contact HRS company.

Note 2. If the without boss specification is required, please contact HRS sales department.

## ■ Receptacle Without metal fitting

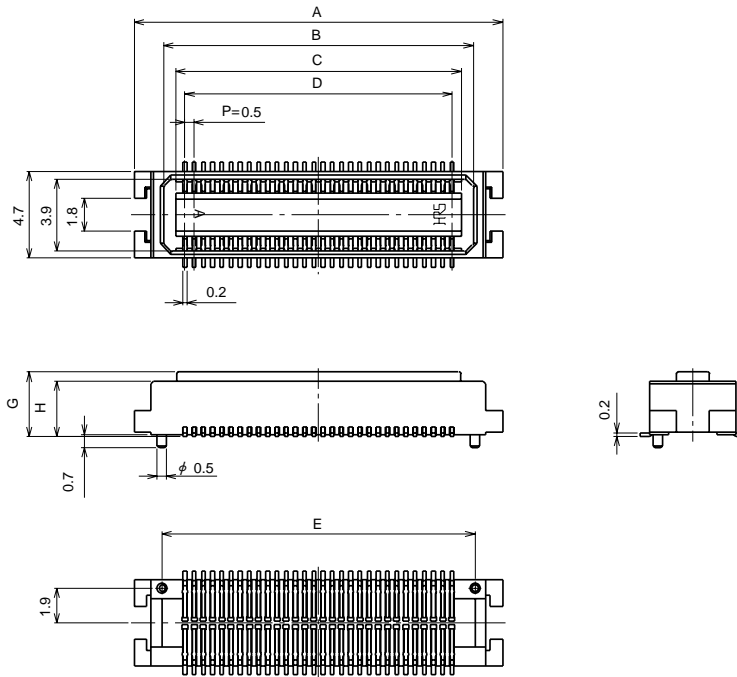
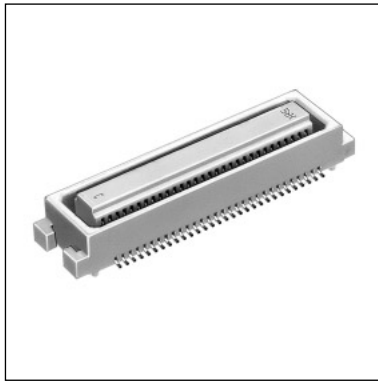

### ● Stacking Height: 4mm

Part Number	CL No.	Number of Contacts	A	B	C	D	E	G	H
DF17A(3.0H)-26DS-0.5V(51)	683-0254-5-51	26	11.5	8.3	7.0	6.0	8.5	3.0	3.0
DF17A(3.0H)-30DS-0.5V(51)	683-0269-2-51	30	12.5	9.3	8.0	7.0	9.5		
DF17A(3.0H)-60DS-0.5V(51)	683-0362-8-51	60	20.0	16.8	15.5	14.5	17.0		

### ● Stacking Height: 5mm, 7mm

Part Number	CL No.	Number of Contacts	A	B	C	D	E	G	H
DF17A(3.0)-20DS-0.5V(51)	683-0012-6-51	20	10.0	6.8	5.5	4.5	7.0	3.5	3.0
DF17A(3.0)-26DS-0.5V(51)	683-0242-6-51	26	11.5	8.3	7.0	6.0	8.5		
DF17A(3.0)-30DS-0.5V(51)	683-0013-9-51	30	12.5	9.3	8.0	7.0	9.5		
DF17A(3.0)-40DS-0.5V(51)	683-0014-1-51	40	15.0	11.8	10.5	9.5	12.0		
DF17A(3.0)-50DS-0.5V(51)	683-0015-4-51	50	17.5	14.3	13.0	12.0	14.5		
DF17A(3.0)-60DS-0.5V(51)	683-0016-7-51	60	20.0	16.8	15.5	14.5	17.0		
DF17A(3.0)-70DS-0.5V(51)	683-0017-0-51	70	22.5	19.3	18.0	17.0	19.5		
DF17A(3.0)-80DS-0.5V(51)	683-0018-2-51	80	25.0	21.8	20.5	19.5	22.0		

### ● Stacking Height: 6mm, 8mm

Part Number	CL No.	Number of Contacts	A	B	C	D	E	G	H
DF17A(4.0)-20DS-0.5V(51)	683-0052-0-51	20	10.0	6.8	5.5	4.5	7.0	4.5	4.0
DF17A(4.0)-30DS-0.5V(51)	683-0053-3-51	30	12.5	9.3	8.0	7.0	9.5		
DF17A(4.0)-40DS-0.5V(51)	683-0054-6-51	40	15.0	11.8	10.5	9.5	12.0		
DF17A(4.0)-50DS-0.5V(51)	683-0055-9-51	50	17.5	14.3	13.0	12.0	14.5		
DF17A(4.0)-60DS-0.5V(51)	683-0056-1-51	60	20.0	16.8	15.5	14.5	17.0		
DF17A(4.0)-70DS-0.5V(51)	683-0057-4-51	70	22.5	19.3	18.0	17.0	19.5		
DF17A(4.0)-80DS-0.5V(51)	683-0058-7-51	80	25.0	21.8	20.5	19.5	22.0		

Note 1. In regard to this product, the embossed tape packaging is the standard packaging. (1000 pcs./ reel.)

If the (50) tube packaging is required, please contact HRS company.

Note 2. If the without boss specification is required, please contact HRS sales department.

## Header With metal fitting

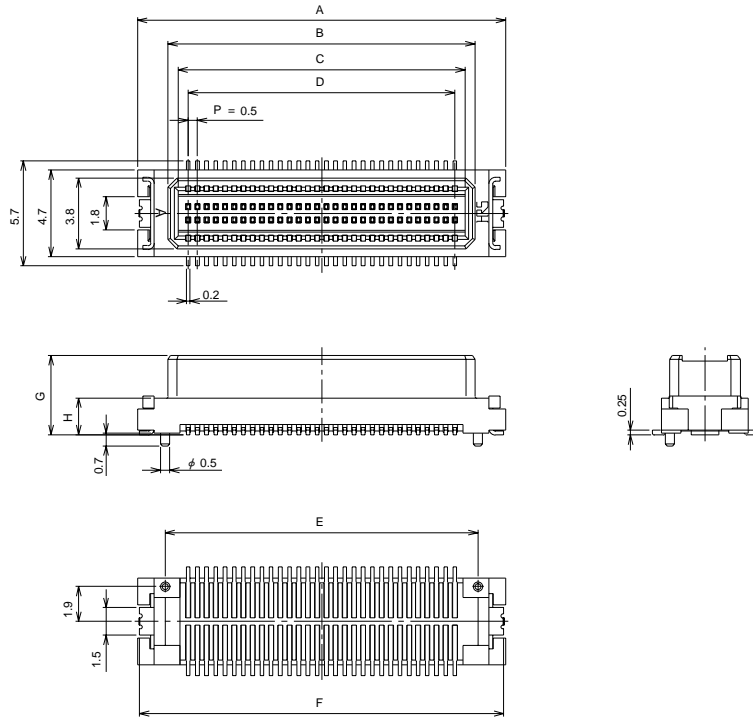
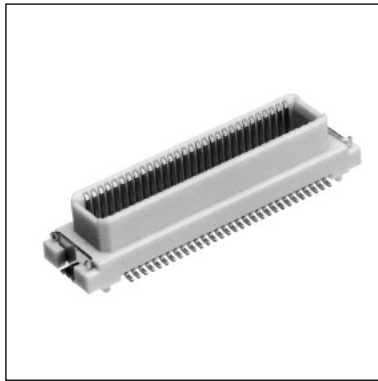

### ● Stacking Height: 4mm

Part Number	CL No.	Number of Contacts	A	B	C	D	E	F	G	H
DF17(1.0H)-26DP-0.5V(51)	683-0257-3-51	26	11.5	8.2	7.1	6.0	8.5	11.3	3.3	1.0
DF17(1.0H)-30DP-0.5V(51)	683-0272-7-51	30	12.5	9.2	8.1	7.0	9.5	12.3		
DF17(1.0H)-60DP-0.5V(51)	683-0365-6-51	60	20.0	16.7	15.6	14.5	17.0	19.8		

### ● Stacking Height: 5mm, 6mm

Part Number	CL No.	Number of Contacts	A	B	C	D	E	F	G	H
DF17(2.0)-20DP-0.5V(51)	683-0082-1-51	20	10.0	6.7	5.6	4.5	7.0	9.8	4.3	2.0
DF17(2.0)-30DP-0.5V(51)	683-0083-4-51	30	12.5	9.2	8.1	7.0	9.5	12.3		
DF17(2.0)-40DP-0.5V(51)	683-0084-7-51	40	15.0	11.7	10.6	9.5	12.0	14.8		
DF17(2.0)-50DP-0.5V(51)	683-0085-0-51	50	17.5	14.2	13.1	12.0	14.5	17.3		
DF17(2.0)-60DP-0.5V(51)	683-0086-2-51	60	20.0	16.7	15.6	14.5	17.0	19.8		
DF17(2.0)-70DP-0.5V(51)	683-0087-5-51	70	22.5	19.2	18.1	17.0	19.5	22.3		
DF17(2.0)-80DP-0.5V(51)	683-0088-8-51	80	25.0	21.7	20.6	19.5	22.0	24.8		

### ● Stacking Height: 7mm, 8mm

Part Number	CL No.	Number of Contacts	A	B	C	D	E	F	G	H
DF17(4.0)-20DP-0.5V(51)	683-0122-4-51	20	10.0	6.7	5.6	4.5	7.0	9.8	6.3	4.0
DF17(4.0)-30DP-0.5V(51)	683-0123-7-51	30	12.5	9.2	8.1	7.0	9.5	12.3		
DF17(4.0)-40DP-0.5V(51)	683-0124-0-51	40	15.0	11.7	10.6	9.5	12.0	14.8		
DF17(4.0)-50DP-0.5V(51)	683-0125-2-51	50	17.5	14.2	13.1	12.0	14.5	17.3		
DF17(4.0)-60DP-0.5V(51)	683-0126-5-51	60	20.0	16.7	15.6	14.5	17.0	19.8		
DF17(4.0)-70DP-0.5V(51)	683-0127-8-51	70	22.5	19.2	18.1	17.0	19.5	22.3		
DF17(4.0)-80DP-0.5V(51)	683-0128-0-51	80	25.0	21.7	20.6	19.5	22.0	24.8		

Note 1. In regard to this product, the embossed tape packaging is the standard packaging. (1000 pcs./reel.)

If the (50) tube packaging is required, please contact HRS company.

Note 2. If the without boss specification is required, please contact HRS sales department.

## Header Without metal fitting

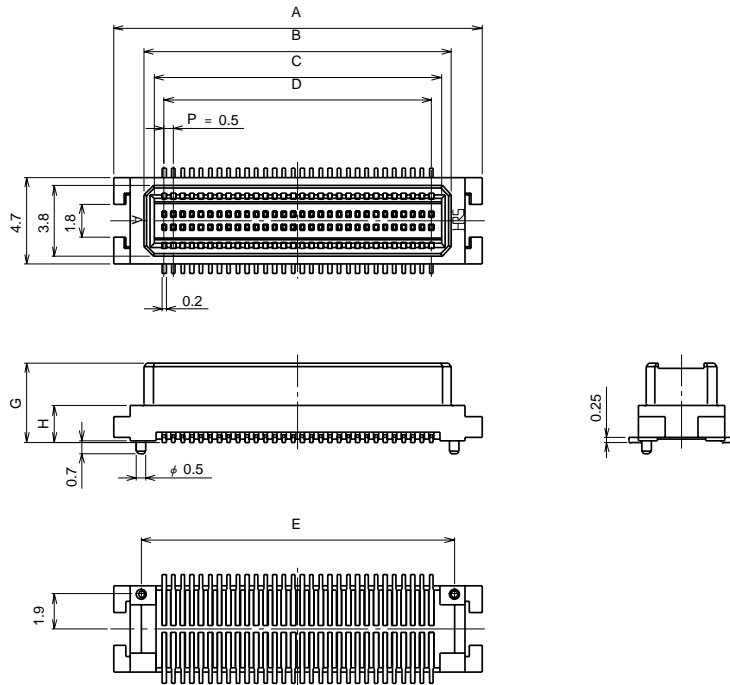
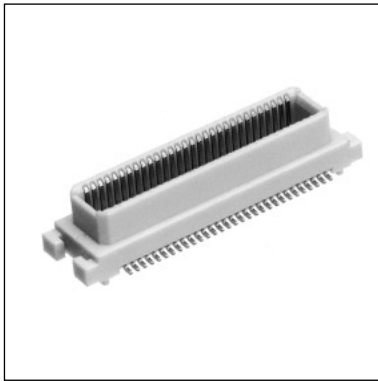

### ● Stacking Height: 4mm

Part Number	CL No.	Number of Contacts	A	B	C	D	E	G	H
DF17A(1.0H)-26DP-0.5V(51)	683-0258-6-51	26	11.5	8.2	7.1	6.0	8.5	3.0	3.0
DF17A(1.0H)-30DP-0.5V(51)	683-0273-0-51	30	12.5	9.2	8.1	7.0	9.5		
DF17A(1.0H)-60DP-0.5V(51)	683-0366-9-51	60	20.0	16.7	15.6	14.5	17.0		

### ● Stacking Height: 5mm, 6mm

Part Number	CL No.	Number of Contacts	A	B	C	D	E	G	H
DF17A(2.0)-20DP-0.5V(51)	683-0092-5-51	20	10.0	6.7	5.6	4.5	7	4.3	2
DF17A(2.0)-30DP-0.5V(51)	683-0093-8-51	30	12.5	9.2	8.1	7	9.5		
DF17A(2.0)-40DP-0.5V(51)	683-0094-0-51	40	15.0	11.7	10.6	9.5	12		
DF17A(2.0)-50DP-0.5V(51)	683-0095-3-51	50	17.5	14.2	13.1	12	14.5		
DF17A(2.0)-60DP-0.5V(51)	683-0096-6-51	60	20.0	16.7	15.6	14.5	17		
DF17A(2.0)-70DP-0.5V(51)	683-0097-9-51	70	22.5	19.2	18.1	17	19.5		
DF17A(2.0)-80DP-0.5V(51)	683-0098-1-51	80	25.0	21.7	20.6	19.5	22		

### ● Stacking Height: 7mm, 8mm

Part Number	CL No.	Number of Contacts	A	B	C	D	E	G	H
DF17A(4.0)-20DP-0.5V(51)	683-0132-8-51	20	10.0	6.7	5.6	4.5	7	6.3	4
DF17A(4.0)-30DP-0.5V(51)	683-0133-0-51	30	12.5	9.2	8.1	7	9.5		
DF17A(4.0)-40DP-0.5V(51)	683-0134-3-51	40	15.0	11.7	10.6	9.5	12		
DF17A(4.0)-50DP-0.5V(51)	683-0135-6-51	50	17.5	14.2	13.1	12	14.5		
DF17A(4.0)-60DP-0.5V(51)	683-0136-9-51	60	20.0	16.7	15.6	14.5	17		
DF17A(4.0)-70DP-0.5V(51)	683-0137-1-51	70	22.5	19.2	18.1	17	19.5		
DF17A(4.0)-80DP-0.5V(51)	683-0138-4-51	80	25.0	21.7	20.6	19.5	22		

Note 1. In regard to this product, the embossed tape packaging is the standard packaging. (1000 pcs./reel.)

If the (50) tube packaging is required, please contact HRS company.

Note 2. If the without boss specification is required, please contact HRS sales department.

## ■ PCB mounting pattern with Metal Fitting

- Receptacle
- Header

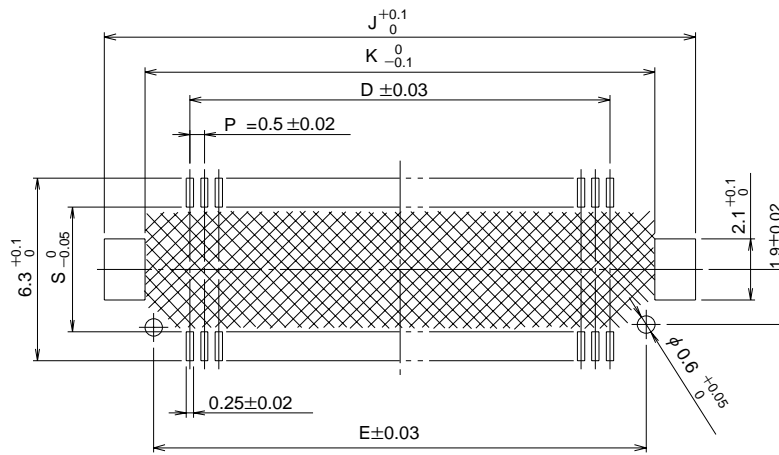

Number of Contacts	D	E	J	K
20	4.5	7.0	10.4	7.6
30	7.0	9.5	12.9	10.1
40	9.5	12.0	15.4	12.6
50	12.0	14.5	17.9	15.1
60	14.5	17.0	20.4	17.6
70	17.0	19.5	22.9	20.1
80	19.5	22.0	25.4	22.6

S	
Receptacle	4.3
Header	4

\* The recommended solder paste thickness is 150μm.

Note 1.  If the pattern is included in the shaded area, and not treated with resist, it could touch the connector contact.

Note 2. If the boss isn't included, the boss hole shown in the above figure isn't required.



## ■PCB mounting pattern without Metal Fitting

- Receptacle
- Header

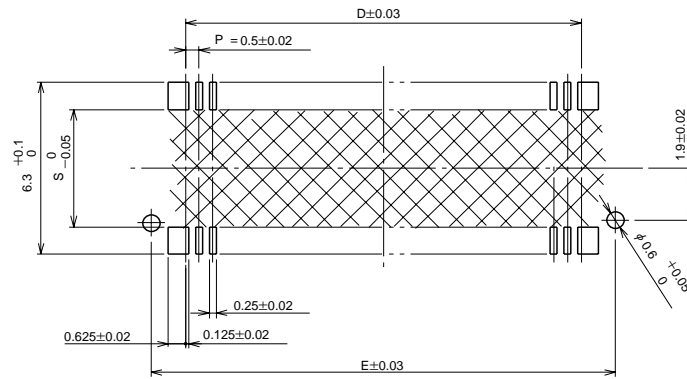

Number of Contacts	D	E
20	4.5	7.0
30	7.0	9.5
40	9.5	12.0
50	12.0	14.5
60	14.5	17.0
70	17.0	19.5
80	19.5	22.0

S	
Receptacle	4.3
Header	4

\* The recommended solder paste thickness is 150 $\mu$ m.

Note 1.  If the pattern is included in the shaded area, and not treated with resist, it could touch the connector contact.

Note 2. If the boss isn't included, the boss hole shown in the above figure isn't required.

# ■ Packaging Specification

## ● Embossed Carrier Tape Dimensions

### ■ Receptacle

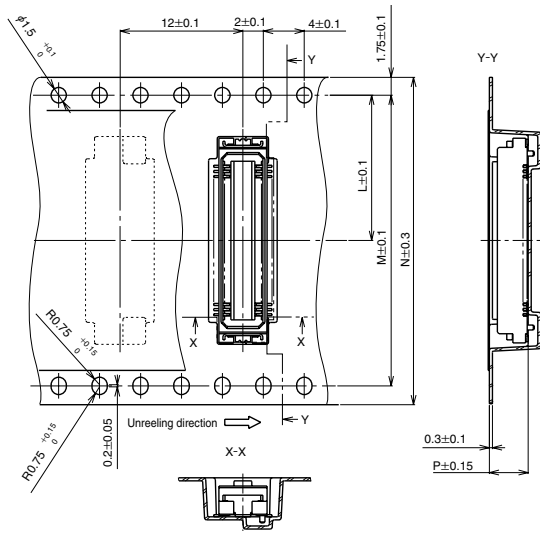

Connector	L	N	P	Q	R
DF17#(3.0)-20DS-0.5V	11.5	24	3.8	24.4	330
DF17#(3.0)-30DS-0.5V	11.5	24	3.8	24.4	330
DF17#(3.0)-40DS-0.5V	11.5	24	3.8	24.4	330

Connector	L	M	N	P	Q	R
DF17#(3.0)-50DS-0.5V	14.2	28.4	32	3.8	32.4	330
DF17#(3.0)-60DS-0.5V	14.2	28.4	32	3.8	32.4	330
DF17#(3.0)-70DS-0.5V	20.2	40.4	44	3.8	44.4	330
DF17#(3.0)-80DS-0.5V	20.2	40.4	44	3.8	44.4	330

Connector	L	N	P	Q	R
DF17#(4.0)-20DS-0.5V	11.5	24	4.8	24.4	330
DF17#(4.0)-30DS-0.5V	11.5	24	4.8	24.4	330
DF17#(4.0)-40DS-0.5V	11.5	24	4.8	24.4	330

Connector	L	M	N	P	Q	R
DF17#(4.0)-50DS-0.5V	14.2	28.4	32	4.8	32.4	330
DF17#(4.0)-60DS-0.5V	14.2	28.4	32	4.8	32.4	330
DF17#(4.0)-70DS-0.5V	20.2	40.4	44	4.8	44.4	330
DF17#(4.0)-80DS-0.5V	20.2	40.4	44	4.8	44.4	330

## ● Reel Dimensions

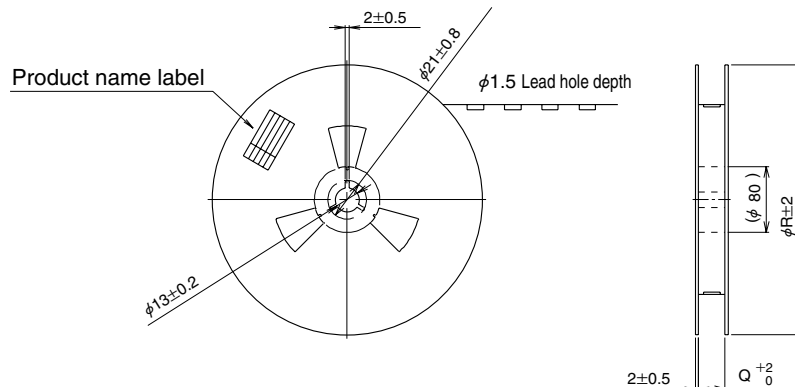

## Header

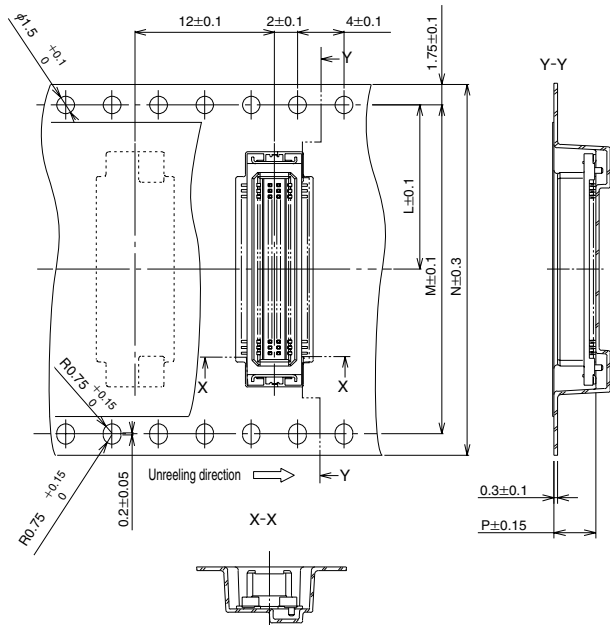

Connector	L	N	P	Q	R
DF17#(2.0)-20DP-0.5V	11.5	24	4.6	24.4	330
DF17#(2.0)-30DP-0.5V	11.5	24	4.6	24.4	330
DF17#(2.0)-40DP-0.5V	11.5	24	4.6	24.4	330

Connector	L	M	N	P	Q	R
DF17#(2.0)-50DP-0.5V	14.2	28.4	32	4.6	32.4	330
DF17#(2.0)-60DP-0.5V	14.2	28.4	32	4.6	32.4	330
DF17#(2.0)-70DP-0.5V	20.2	40.4	44	4.6	44.4	330
DF17#(2.0)-80DP-0.5V	20.2	40.4	44	4.6	44.4	330

Connector	L	N	P	Q	R
DF17#(4.0)-20DP-0.5V	11.5	24	6.6	24.4	380
DF17#(4.0)-30DP-0.5V	11.5	24	6.6	24.4	380
DF17#(4.0)-40DP-0.5V	11.5	24	6.6	24.4	380

Connector	L	M	N	P	Q	R
DF17#(4.0)-50DP-0.5V	14.2	28.4	32	6.6	32.4	380
DF17#(4.0)-60DP-0.5V	14.2	28.4	32	6.6	32.4	380
DF17#(4.0)-70DP-0.5V	20.2	40.4	44	6.6	44.4	380
DF17#(4.0)-80DP-0.5V	20.2	40.4	44	6.6	44.4	380

## ● Reel Dimensions

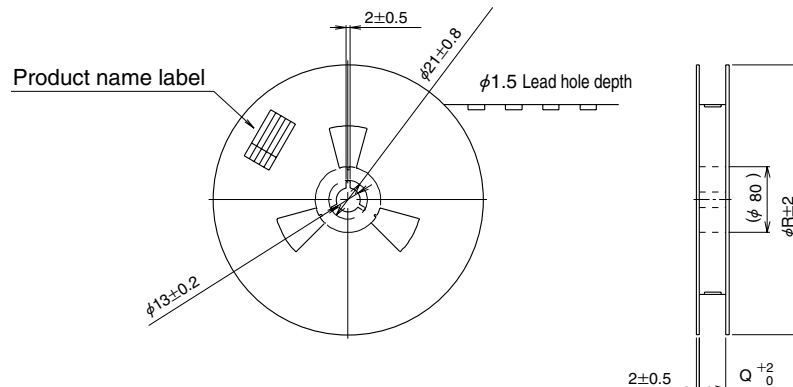

## ■ Precautions

<p>1. Recommended Temperature Profile (SMT)</p>	<p>Note 1. Maximum twice action is allowed under the same condition. However, the interval between the first and second actions must be maintained at the room temperature.</p> <p>Note 2. The temperature indicates the board surface temperature of the connector lead area.</p>
<p>2. Recommended Manual Soldering Condition (SMT)</p>	<p>Soldering iron temperature: <math>290 \pm 10^\circ\text{C}</math> Soldering time: Within 2 seconds</p>
<p>3. Recommended Screen Thickness (SMT)</p>	<p>0.15mm</p>
<p>4. Board Warp(SMT)</p>	<p>Max 0.2mm in the connector center area, based on the both connector edges</p>
<p>5. Cleaning Condition</p>	<p>Refer to the "Nylon Connector Use Hand book".</p>
<p>6. Cautions</p>	<ul style="list-style-type: none"> <li>■ The header is designed in a structure where contacts are exposed. Touching it with bare hands would cause contact failure or electrostatic element damage.</li> <li>■ Where no board is mounted, the insertion or extraction will cause damage or contact deformation.</li> <li>■ Avoid retaining the board with the connector only, and fix the board by any other means than the connector.</li> <li>■ Excessive scoop insertion or extraction may result in damage.</li> <li>■ In the manual soldering process, don't carry out the flux coating which will cause a flux blister on the connector.</li> <li>■ The color phase of this product may be slightly different from that of the formed product according to the manufacturing lot. However, the difference doesn't affect the performance.</li> </ul>