

Dual-Channel Temperature Monitors and Fan-Speed Controllers with Thermistor Inputs

General Description

The MAX6615/MAX6616 monitor two temperature channels, either the internal die temperature and the temperature of an external thermistor, or the temperatures of two external thermistors. The temperature data controls a PWM output signal to adjust the speed of a cooling fan, thereby minimizing noise when the system is running cool, but providing maximum cooling when power dissipation increases. The fans' tachometer output signals are monitored by the MAX6615/MAX6616 to detect fan failure. If a fan failure is detected, the $\overline{\text{FAN_FAIL}}$ output is asserted.

The 2-wire serial interface accepts standard system management bus (SMBus™) write byte, read byte, send byte, and receive byte commands to read the temperature data and program the alarm thresholds. The programmable alarm output can be used to generate interrupts, throttle signals, or overtemperature shutdown signals.

The MAX6616 features six GPIOs to provide additional flexibility. All of the GPIOs power-up as inputs, with the exception of GPIO0, which powers up as either an input or an output as determined by connecting the PRESET pin to ground or VCC.

The MAX6616 is available in a 24-pin QSOP package, while the MAX6615 is available in a 16-pin QSOP package. Both devices operate from a single-supply voltage range of 3.0V to 5.5V, have operating temperature ranges of -40°C to +125°C, and consume just 500µA of supply current.

Applications

Desktop Computers
Servers
Power Supplies
Networking Equipment
Workstations

SMBus is a trademark of Intel Corp.

Typical Application Circuits and Pin Configurations appear at end of data sheet.

Features

- ◆ Two Thermistor Inputs
- ◆ Two Open-Drain PWM Outputs for Fan-Speed Control
- ◆ Local Temperature Sensor
- ◆ Six GPIOs (MAX6616)
- ◆ Programmable Fan-Control Characteristics
- ◆ Controlled PWM Rate-of-Change Ensures Unobtrusive Fan-Speed Adjustments
- ◆ Fail-Safe System Protection
- ◆ $\overline{\text{OT}}$ Output for Throttling or Shutdown
- ◆ Nine Different Pin-Programmable SMBus Addresses
- ◆ 16-Pin and 24-Pin QSOP Packages

Ordering Information

PART	TEMP RANGE	PIN-PACKAGE
MAX6615AEE	-40°C to +125°C	16 QSOP
MAX6616AEG	-40°C to +125°C	24 QSOP

Functional Diagram

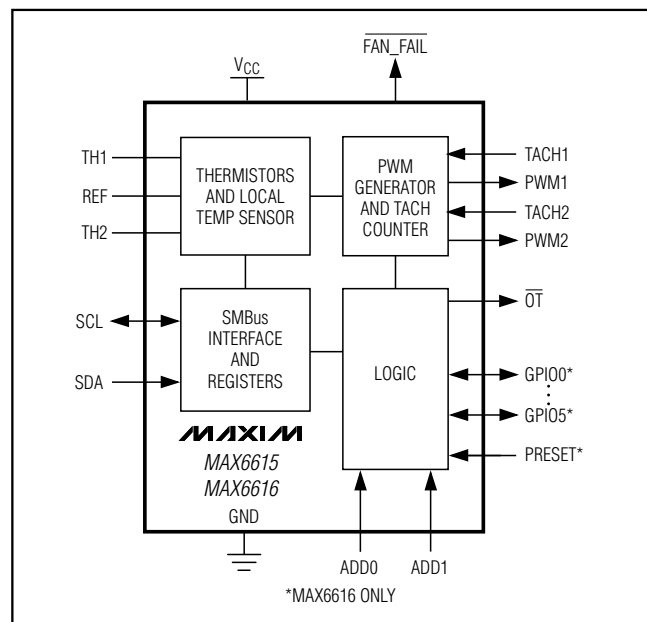

Dual-Channel Temperature Monitors and Fan-Speed Controllers with Thermistor Inputs

ABSOLUTE MAXIMUM RATINGS

All Voltages Are Referenced to GND

Supply Voltage (V_{CC})	-0.3V to +6V
PWM_, TACH_, OT, FAN_FAIL	-0.3V to +13.5V
ADD0, ADD1, SDA, SCL	-0.3V to +6V
All Other Pins	-0.3V to ($V_{CC} + 0.3V$)
SDA, OT, FAN_FAIL, PWM_, GPIO_ Current	$\pm 50mA$
TH_ Current	$\pm 1mA$
REF Current	$\pm 20mA$

Continuous Power Dissipation ($T_A = +70^\circ C$)

16-Pin QSOP (derated at 8.3mW/ $^\circ C$ above $+70^\circ C$)	666.7mW
24-Pin QSOP (derated at 9.5mW/ $^\circ C$ above $+70^\circ C$)	761.9 mW
ESD Protection (all pins, Human Body Model)	$\pm 2kV$
Operating Temperature Range	$-40^\circ C$ to $+125^\circ C$
Junction Temperature	$+150^\circ C$
Storage Temperature Range	$-65^\circ C$ to $+150^\circ C$
Lead Temperature (soldering, 10s)	$+300^\circ C$

Stresses beyond those listed under "Absolute Maximum Ratings" may cause permanent damage to the device. These are stress ratings only, and functional operation of the device at these or any other conditions beyond those indicated in the operational sections of the specifications is not implied. Exposure to absolute maximum rating conditions for extended periods may affect device reliability.

ELECTRICAL CHARACTERISTICS

($V_{CC} = +3.0V$ to $+5.5V$, $T_A = 0^\circ C$ to $+125^\circ C$, unless otherwise noted. Typical values are at $V_{CC} = +3.3V$, $T_A = +25^\circ C$.)

PARAMETER	SYMBOL	CONDITIONS	MIN	TYP	MAX	UNITS
Operating Supply Voltage	V_{CC}		3.0		5.5	V
Standby Current		Interface inactive, ADC in idle state			10	μA
Operating Current	I_S	Interface inactive, ADC active		0.5	1	mA
External Temperature Error		$V_{CC} = +3.3V$, $0.15V \leq V_{TH} \leq +0.71V$ (excludes thermistor errors, thermistor nonlinearity) (Note1)			± 1	$^\circ C$
Internal Temperature Error		$V_{CC} = +3.3V$, $0^\circ C \leq T_A \leq +85^\circ C$,			± 2.5	$^\circ C$
		$V_{CC} = +3.3V$, $0^\circ C \leq T_A \leq +125^\circ C$			± 4	
Temperature Resolution			0.125			$^\circ C$
Conversion Time				250		ms
Conversion Rate Timing Error			-20		+20	%
PWM Frequency Error			-20		+20	%
INPUT/OUTPUT						
Output Low Voltage	V_{OL}	$V_{CC} = +3V$, $I_{OUT} = 6mA$			0.4	V
Output High Leakage Current	I_{OH}				1	μA
Logic Low Input Voltage	V_{IL}				0.8	V
Logic High Input Voltage	V_{IH}		2.1			V
Input Leakage Current					1	μA
Input Capacitance	C_{IN}			5		pF
SMBus TIMING (Figures 2, 3) (Note 2)						
Serial Clock Frequency	f_{SCLK}		10		400	kHz
Clock Low Period	t_{LOW}	10% to 10%	4			μs
Clock High Period	t_{HIGH}	90% to 90%	4.7			μs
Bus Free Time Between STOP and START Conditions	t_{BUF}		4.7			μs
SMBus START Condition Setup Time	$t_{SU:STA}$	90% of SCL to 90% of SDA	4.7			μs

Dual-Channel Temperature Monitors and Fan-Speed Controllers with Thermistor Inputs

MAX6615/MAX6616

ELECTRICAL CHARACTERISTICS (continued)

($V_{CC} = +3.0V$ to $+5.5V$, $T_A = 0^{\circ}C$ to $+125^{\circ}C$, unless otherwise noted. Typical values are at $V_{CC} = +3.3V$, $T_A = +25^{\circ}C$.)

PARAMETER	SYMBOL	CONDITIONS	MIN	TYP	MAX	UNITS
START Condition Hold Time	$t_{HD:STO}$	10% of SDA to 10% of SCL	4			μs
STOP Condition Setup Time	$t_{SU:STO}$	90% of SCL to 10% of SDA	4			μs
Data Setup Time	$t_{SU:DAT}$	10% of SDA to 10% of SCL	250			ns
Data Hold Time	$t_{HD:DAT}$	10% of SCL to 10% of SDA	300			ns
SMBus Fall Time	t_F				300	ns
SMBus Rise Time	t_R				1000	ns
SMBus Timeout		(Note 3)	29	37	55	ms

Note 1: $1^{\circ}C$ of error corresponds to an ADC error of 7.76mV when $V_{REF} = 1V$.

Note 2: Guaranteed by design and characterization.

Note 3: Production tested.

Typical Operating Characteristics

($V_{CC} = +3.3V$, $T_A = +25^{\circ}C$, unless otherwise noted.)

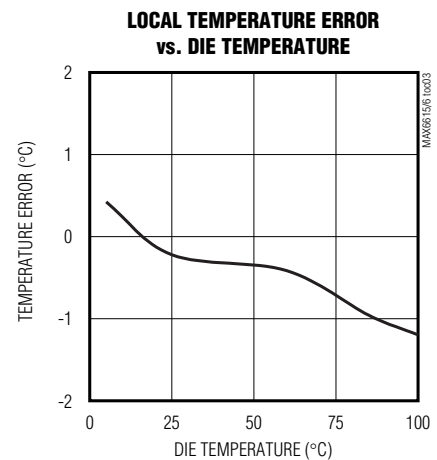
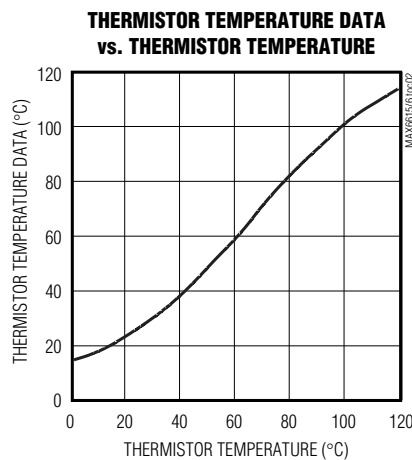
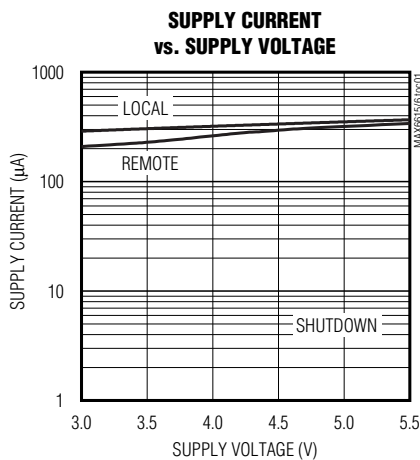

Dual-Channel Temperature Monitors and Fan-Speed Controllers with Thermistor Inputs

Typical Operating Characteristics (continued)

($V_{CC} = +3.3V$, $T_A = +25^\circ C$, unless otherwise noted.)

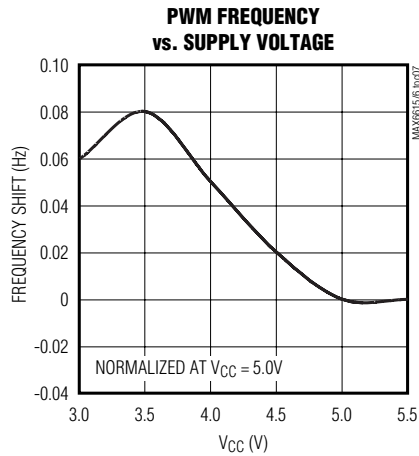
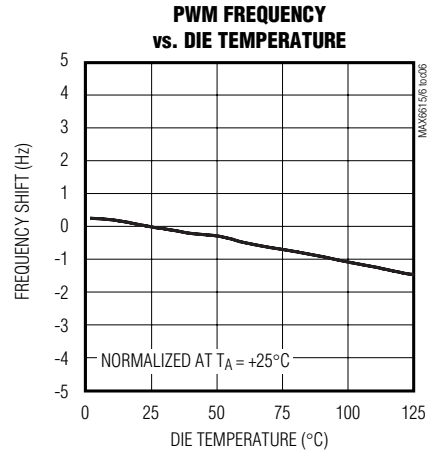
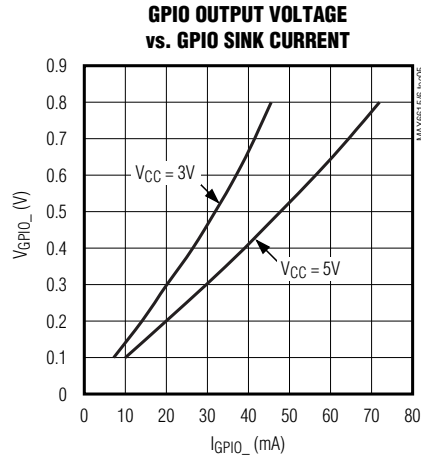
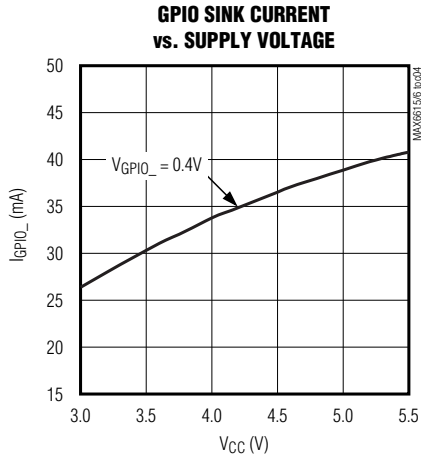

Dual-Channel Temperature Monitors and Fan-Speed Controllers with Thermistor Inputs

Pin Description

MAX6615/MAX6616

PIN		NAME	FUNCTION
MAX6616	MAX6615		
1, 2, 5, 20, 23, 24	—	GPIO0–GPIO5	Active-Low, Open-Drain GPIOs. Can be pulled up to 5.5V regardless of V _{CC} .
3	1	PWM1	Fan Driver Output 1. The pullup resistor can be connected to a supply voltage as high as 12V, regardless of the supply voltage. See the <i>PWM Output</i> section for configuration.
4	2	TACH1	Fan Tachometer Input. Accepts logic-level signal from fan's tachometer output. Can be connected to a supply voltage as high as 12V, regardless of the supply voltage.
6	3	ADD0	SMBus Slave Address Selection
7	4	ADD1	SMBus Slave Address Selection
8	5, 10	GND	Ground. Must be connected together for MAX6615.
9	6	TH1	External Thermistor Input 1. Connect a thermistor in series with a fixed resistor between REF and ground.
10, 15	—	N.C.	No Connection
11	7	REF	Reference Voltage Output. Provides 1V during measurements. High impedance when not measuring.
12	8	TH2	External Thermistor Input 2. Connect a thermistor in series with a fixed resistor between REF and ground.
13	9	$\overline{\text{FAN_FAIL}}$	Fan-Failure Output. Asserts low when either fan fails. Can be pulled up as high as 5.5V regardless of V _{CC} . High impedance when V _{CC} = 0V.
14	—	PRESET	Connect to GND or V _{CC} to set POR state of the GPIO0.
16	11	$\overline{\text{OT}}$	Overtemperature Output. Active low, open drain. Typically used for system shutdown or clock throttling. Can be pulled up as high as 5.5V regardless of V _{CC} . High impedance when V _{CC} = 0V.
17	12	V _{CC}	Power Supply. 3.3V nominal. Bypass with a 0.1μF capacitor to GND.
18	13	SDA	SMBus Serial-Data Input/Output. Pull up with a 10kΩ resistor. Can be pulled up as high as 5.5V regardless of V _{CC} . High impedance when V _{CC} = 0V.
19	14	SCL	SMBus Serial-Clock Input. Pull up with a 10kΩ resistor. Can be pulled up as high as 5.5V regardless of V _{CC} . High impedance when V _{CC} = 0V.
21	15	TACH2	Fan Tachometer Input. Accepts logic-level signal from fan's tachometer output. Can be connected to a supply voltage as high as 12V, regardless of the supply voltage.
22	16	PWM2	Fan Driver Output 2. The pullup resistor can be connected to a supply voltage as high as 12V, regardless of the supply voltage. See the <i>PWM Output</i> section for configuration.

Dual-Channel Temperature Monitors and Fan-Speed Controllers with Thermistor Inputs

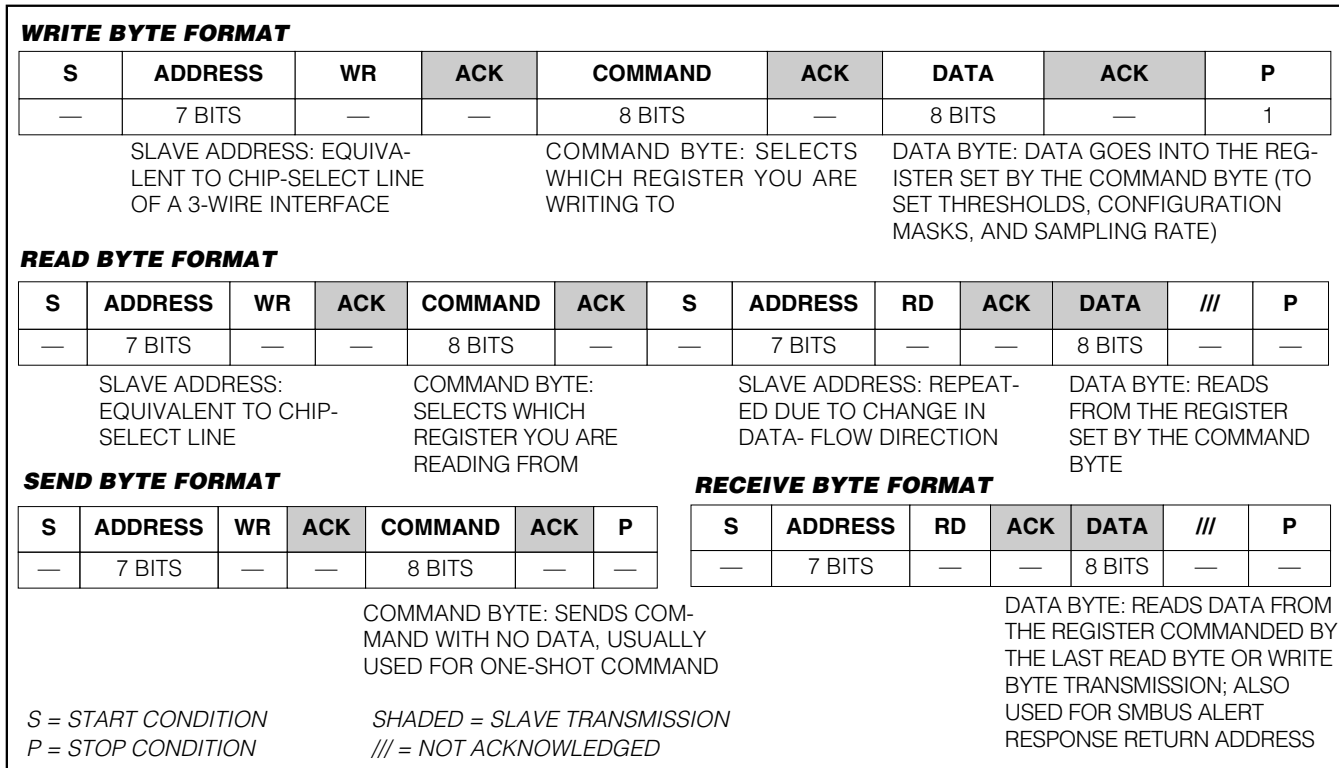

Figure 1. SMBus Protocols

Detailed Description

The MAX6615/MAX6616 accurately monitor two temperature channels, either the internal die temperature and the temperature of an external thermistor, or the temperatures of two external thermistors. They report temperature values in digital form using a 2-wire SMBus/I²C*-compatible serial interface. The MAX6615/MAX6616 operate from a supply voltage range of 3.0V to 5.5V and consume 500µA (typ) of supply current.

The temperature data controls the duty cycles of two PWM output signals that are used to adjust the speed of a cooling fan. They also feature an overtemperature alarm output to generate interrupts, throttle signals, or shutdown signals.

The MAX6616 also includes six GPIO input/outputs to provide additional flexibility. The GPIO0 power-up state is set by connecting the GPIO PRESET input to ground or VCC.

SMBus Digital Interface

From a software perspective, the MAX6615/MAX6616 appear as a set of byte-wide registers. Their devices use a standard SMBus 2-wire/I²C-compatible serial interface to access the internal registers. The MAX6615/MAX6616

have nine different slave addresses available; therefore, a maximum of nine MAX6615/MAX6616 devices can share the same bus.

The MAX6615/MAX6616 employ four standard SMBus protocols: write byte, read byte, send byte, and receive byte (Figures 1, 2, and 3). The shorter receive byte protocol allows quicker transfers, provided that the correct data register was previously selected by a read byte instruction. Use caution with the shorter protocols in multimaster systems, since a second master could overwrite the command byte without informing the first master.

Temperature data can be read from registers 00h and 01h. The temperature data format for these registers is 8 bits, with the LSB representing 1°C (Table 1) and the MSB representing 128°C. The MSB is transmitted first. All values below 0°C clip to 00h.

Table 3 details the register address and function, whether they can be read or written to, and the power-on reset

*Purchase of I²C components from Maxim Integrated Products, Inc., or one of its sublicensed Associated Companies, conveys a license under the Philips I²C Patent Rights to use these components in an I²C system, provided that the system conforms to the I²C Standard Specification as defined by Philips.

Dual-Channel Temperature Monitors and Fan-Speed Controllers with Thermistor Inputs

MAX6615/MAX6616

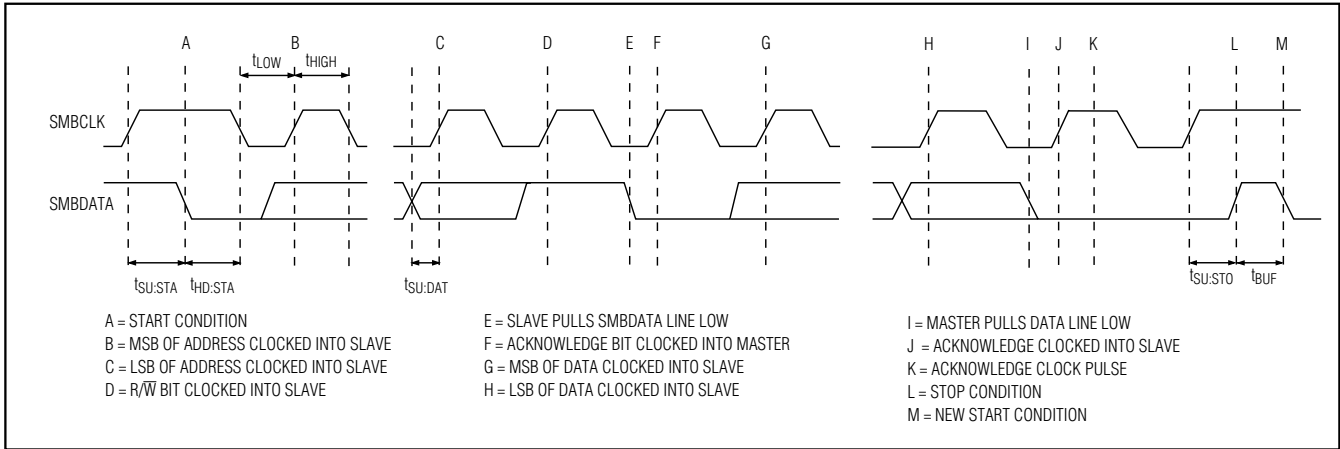

Figure 2. SMBus Write Timing Diagram

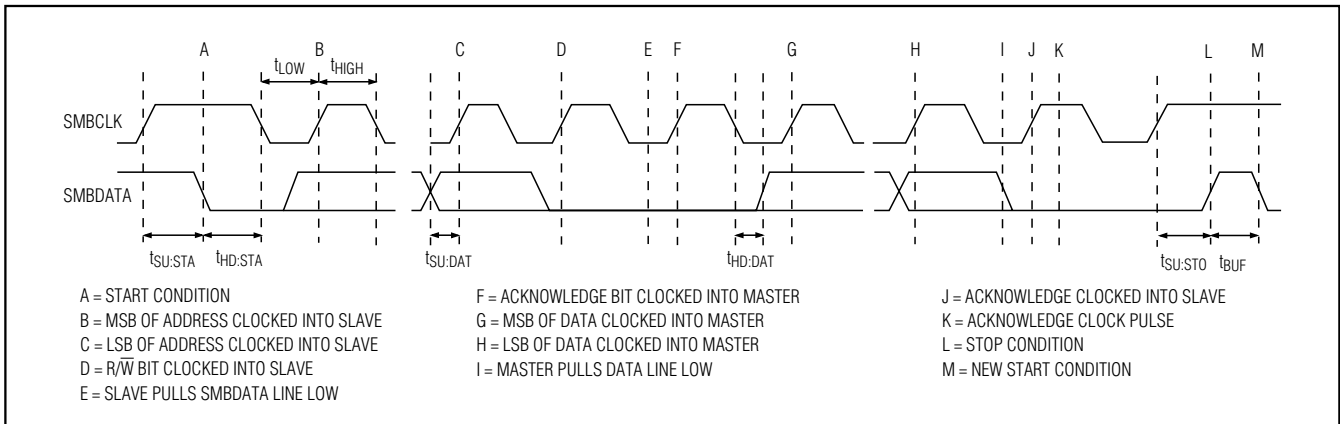

Figure 3. SMBus Read Timing Diagram

(POR) state. See Tables 3–7 for all other register functions and the *Register Descriptions* section.

Temperature Measurements

The averaging ADC integrates over a 120ms period (each channel, typically), with excellent noise rejection. For internal temperature measurements, the ADC and associated circuitry measure the forward voltage of the internal sensing diode at low- and high-current levels and compute the temperature based on this voltage. For thermistor measurements, the reference voltage and the thermistor voltage are measured and offset is applied to yield a value that correlates well to thermistor temperature within a wide temperature range. Both channels are automatically converted once the conversion process has started. If one of the two channels is not used, the circuit still performs both measurements, and the data from the unused channel may be ignored. If either of the measured temperature values is below

0°, the value in the corresponding temperature register is clipped to zero when a negative offset is programmed into the thermistor offset register (17h).

Local (internal) temperature data is expressed directly in degrees Celsius. Two registers contain the temperature data for the local channel. The high-byte register has an MSB of 128°C and an LSB of 1°C. The low-byte register contains 3 bits, with an MSB of 0.5°C and an LSB of 0.125°C. The data format is shown in Table 1.

Thermistors allow measurements of external temperatures. Connect a thermistor in series with a resistor, R_{EXT} . The thermistor should be connected between the TH_ input and ground, and R_{EXT} should be connected between the reference output, REF, and the TH_ input, as shown in the *Typical Application Circuit*.

The voltage across R_{EXT} is measured by the ADC, resulting in a value that is directly related to tempera-

Dual-Channel Temperature Monitors and Fan-Speed Controllers with Thermistor Inputs

Table 1. Temperature Data Format (High Byte and Low Byte)

TEMPERATURE (°C)	HIGH BYTE		LOW BYTE	
	BINARY VALUE	HEX VALUE	BINARY VALUE	HEX VALUE
140.0	1000 1100	8Ch	0000 0000	00h
127.0	0111 1111	7Fh	0000 0000	00h
25.375	0001 1001	19h	0110 0000	60h
25.0	0001 1001	19h	0000 0000	00h
0.5	0000 0000	00h	1000 0000	80h
0.0	0000 0000	00h	0000 0000	00h
<0	0000 0000	00h	0000 0000	00h

ture. The thermistor data in the temperature register(s) gives the voltage across R_{EXT} as a fraction of the reference voltage. The LSB of the high byte has a nominal weight of 7.68mV.

\overline{OT} Output

The \overline{OT} output asserts when a thermal fault occurs, and can therefore be used as a warning flag to initiate system shutdown, or to throttle clock frequency. When temperature exceeds the \overline{OT} temperature threshold and \overline{OT} is not masked, the \overline{OT} status register indicates a fault and \overline{OT} output becomes asserted. If \overline{OT} for the respective channel is masked off, the \overline{OT} status register continues to be set, but the \overline{OT} output does not become asserted.

The fault flag and the output can be cleared by reading the \overline{OT} status register. The \overline{OT} output can also be cleared by masking the affected channel. If the \overline{OT} status bit is cleared, \overline{OT} reasserts on the next conversion if the temperature still exceeds the \overline{OT} temperature threshold.

PWM Output

The PWM_ signals are normally used in one of three ways to control the fan's speed:

- 1) PWM_ drives the gate of a MOSFET or the base of a bipolar transistor in series with the fan's power supply. The *Typical Application Circuit* shows the PWM_ driving an n-channel MOSFET. In this case, the PWM invert bit (D4 in register 02h) is set to 1. Figure 4 shows PWM_ driving a p-channel MOSFET and the PWM invert bit must be set to zero.
- 2) PWM_ is converted (using an external circuit) into a DC voltage that is proportional to duty cycle. This duty-cycle-controlled voltage becomes the power supply for the fan. This approach is less efficient than (1), but can result in quieter fan operation. Figure 5 shows an example of a circuit that converts the PWM signal to a DC voltage. Because this circuit

produces a full-scale output voltage when PWM = 0V, bit D4 in register 02h should be set to zero.

- 3) PWM_ directly drives the logic-level PWM speed-control input on a fan that has this type of input. This approach requires fewer external components and combines the efficiency of (1) with the low noise of (2). An example of PWM_ driving a fan with a speed-control input is shown in Figure 6. Bit D4 in register 02h should be set to 1 when this configuration is used.

Whenever the fan has to start turning from a motionless state, PWM_ is forced high for 2s. After this spin-up period, the PWM_ duty cycle settles to the predetermined value. Whenever spin-up is disabled (bit 2 in the configuration byte = 1) and the fan is off, the duty cycle changes immediately from zero to the nominal value, ignoring the duty-cycle rate-of-change setting.

The frequency-select register controls the frequency of the PWM signal. When the PWM signal modulates the power supply of the fan, a low PWM frequency (usually 33Hz) should be used to ensure the circuitry of the

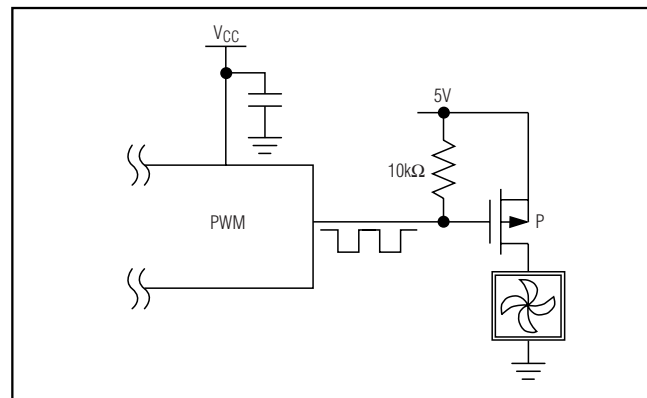

Figure 4. Driving a p-Channel MOSFET for Top-Side PWM Fan Drive

Dual-Channel Temperature Monitors and Fan-Speed Controllers with Thermistor Inputs

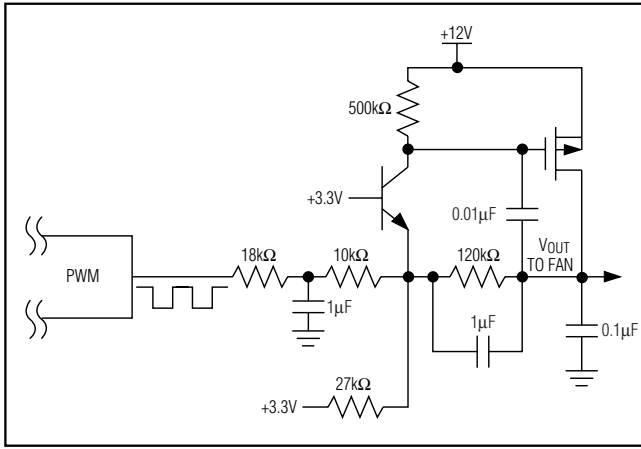

Figure 5. Driving a Fan with a PWM-to-DC Circuit

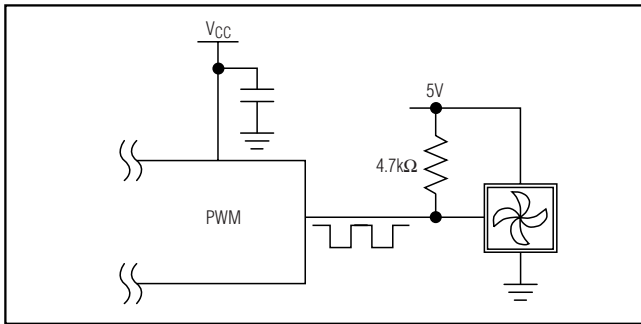

Figure 6. Controlling a PWM Input Fan with the MAX6615/MAX6616's PWM Output (Typically, the 35kHz PWM Frequency Is Used)

brushless DC motor has enough time to operate. When driving a fan with a PWM-to-DC circuit as shown in Figure 5, the highest available frequency (35kHz) should be used to minimize the size of the filter capacitors. When using a fan with a PWM control input, the frequency normally should be high as well, although some fans have PWM inputs that accept low-frequency drive.

The duty cycle of the PWM can be controlled in two ways:

- 1) Manual PWM control: setting the duty cycle of the fan directly through the fan target duty-cycle registers (0Bh and 0Ch).
- 2) Automatic PWM control: setting the duty cycle based on temperature.

Manual PWM Duty-Cycle Control

Clearing the bits that select the temperature channels for fan control (D5 and D4 for PWM1 and D3 and D2 for PWM2) in the fan-configuration register (11h) enables manual fan control. In this mode, the duty cycle written to the fan target duty-cycle register directly controls the

corresponding fan. The value is clipped to a maximum of 240. Any value entered above that is changed to 240 automatically. In this control mode, the value in the maximum duty-cycle register is ignored and does not affect the duty cycle used to control the fan.

Automatic PWM Duty-Cycle Control

In the automatic control mode, the duty cycle is controlled by the local or remote temperature according to the settings in the control registers. Below the fan-start temperature, the duty cycle is either 0% or is equal to the fan-start duty cycle, depending on the value of bit D3 in the configuration byte register. Above the fan-start temperature, the duty cycle increases by one duty-cycle step each time the temperature increases by one temperature step. The target duty cycle is calculated based on the following formula; for temperature > FanStartTemperature:

$$DC = FSDC + (T - FST) \times \frac{DCSS}{TS}$$

where:

DC = DutyCycle

FSDC = FanStartDutyCycle

T = Temperature

FST = FanStartTemperature

DCSS = DutyCycleStepSize

TS = TempStep

Duty cycle is recalculated after each temperature conversion if temperature is increasing. If the temperature begins to decrease, the duty cycle is not recalculated until the temperature drops by 5°C from the last peak temperature. The duty cycle remains the same until the temperature drops 5°C from the last peak temperature or the temperature rises above the last peak temperature. For example, if the temperature goes up to +85°C and starts decreasing, duty cycle is not recalculated until the temperature reaches +80°C or the temperature rises above +85°C. If the temperature decreases further, the duty cycle is not updated until it reaches +75°C.

For temperature < FanStartTemperature and D2 of configuration register = 0:

$$\text{DutyCycle} = 0$$

For temperature < FanStartTemperature and D2 of configuration register = 1:

$$\text{DutyCycle} = \text{FanStartDutyCycle}$$

Once the temperature crosses the fan-start temperature threshold, the temperature has to drop below the fan-start temperature threshold minus the hysteresis before

Dual-Channel Temperature Monitors and Fan-Speed Controllers with Thermistor Inputs

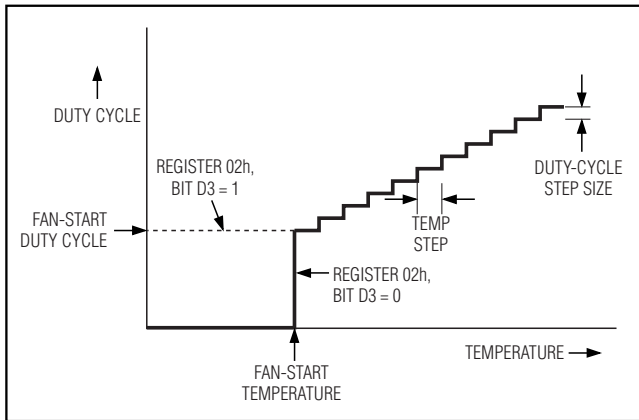

Figure 7. Automatic PWM Duty Control

the duty cycle returns to either 0% or the fan-start duty cycle. The value of the hysteresis is set by D7 of the fan-configuration register.

The duty cycle is limited to the value in the fan maximum duty-cycle register. If the duty-cycle value is larger than the maximum fan duty cycle, it is set to the maximum fan-duty cycle as in the fan maximum duty-cycle register. The temperature step is bit D6 of the fan-configuration register (0Dh).

Notice if temperature crosses FanStartTemperature going up with an initial DutyCycle of zero, a spin-up of 2s applies before the duty-cycle calculation controls the value of the fan's duty cycle.

FanStartTemperature for a particular channel follows the channel, not the fan. If DutyCycle is an odd number, it is automatically rounded down to the closest even number.

Duty-Cycle Rate-of-Change Control

To reduce the audibility of changes in fan speed, the rate of change of the duty cycle is limited by the values set in the duty-cycle rate-of-change register. Whenever the target duty cycle is different from the instantaneous duty cycle, the duty cycle increases or decreases at the rate determined by the duty-cycle rate-of-change byte until it reaches the target duty cycle. By setting the rate of change to the appropriate value, the thermal requirements of the system can be balanced against good acoustic performance. Slower rates of change are less noticeable to the user, while faster rates of change can help minimize temperature variations. Remember that the fan controller is part of a complex control system. Because several of the parameters are generally not known, some experimentation may be necessary to arrive at the best settings.

Fan-Fail

When the fan tachometer count is larger than the fan tachometer limit, the fan is considered failing. The MAX6615/MAX6616 PWM_ drives the fan with 100% duty cycle for about 2s immediately after detecting a fan-fail. At the end of that period, another measurement is initiated. If the fan fails both measurements, the FAN_FAIL bit, as well as the FAN_FAIL output, assert if the pin is not masked. If the fan fails only the first measurement, the fan goes back to normal settings.

If one fan fails, it can be useful to drive the other fan with 100% duty cycle. This can be enabled with bit D0 of the fan-status register (1Ch).

Slave Addresses

The MAX6615/MAX6616 appear to the SMBus as one device having a common address for both ADC channels. The devices' address can be set to one of nine different values by pinstrapping ADD0 and ADD1 so that more than one MAX6615/MAX6616 can reside on the same bus without address conflicts (see Table 2).

The address input states are checked regularly, and the address data stays latched to reduce quiescent supply current due to the bias current needed for high-impedance state detection.

Power-On Defaults

At power-on, or when the POR bit in the configuration byte register is set, the MAX6615/MAX6616 have the default settings indicated in Table 3. Some of these settings are summarized below:

- Temperature conversions are active.
- Channel 1 and channel 2 are set to report the remote temperature channel measurements.
- Channel 1 \overline{OT} limit = +110°C.
- Channel 2 \overline{OT} limit = +80°C.
- Manual fan mode.
- Fan duty cycle = 0.
- PWM invert bit = 0.

Dual-Channel Temperature Monitors and Fan-Speed Controllers with Thermistor Inputs

Table 2. Slave Address Decoding (ADD0 and ADD1)

ADD0	ADD1	ADDRESS
GND	GND	0011 000
GND	High-Impedance	0011 001
GND	V _{CC}	0011 010
High-Impedance	GND	0101 001
High-Impedance	High-Impedance	0101 010
High-Impedance	V _{CC}	0101 011
V _{CC}	GND	1001 100
V _{CC}	High-Impedance	1001 101
V _{CC}	V _{CC}	1001 110

Note: High-Impedance means that the pin is left unconnected and floating.

GPIO Inputs/Outputs and Preset (MAX6616)

The MAX6616 has six GPIO ports. GPIO0 has a POR control pin (PRESET). When PRESET is connected to GND at POR, GPIO0 is configured as an output and is low. When PRESET is connected to V_{CC} at POR, GPIO0 is configured as an input. Since GPIO0 is a high-impedance node in this state, it can be connected to a pullup resistor and also serve as an output (high). The rest of the GPIO ports, GPIO5–GPIO1, are configured as high-impedance outputs after power-on, so they will be in the high state if connected to pullup resistors. All GPIOs are at their preset values within 1ms of power-up. During power-up, GPIO1 and GPIO2 are low while the remaining GPIOs go into high-impedance state. Figure 8 shows the states of the GPIO lines during power-up. After power has been applied to the MAX6616, the GPIO functions can be changed through the SMBus interface.

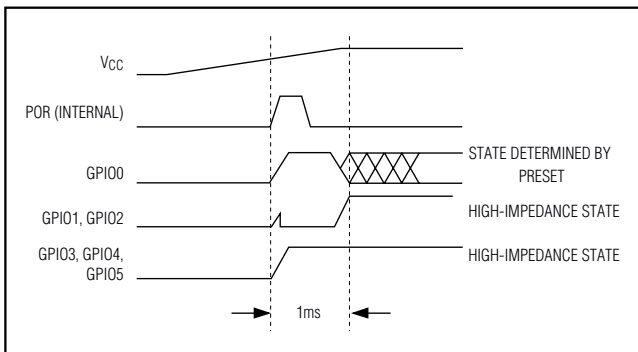

Figure 8. Power-On GPIO States

Register Descriptions

The MAX6615/MAX6616 contain 32/34 internal registers. These registers store temperature data, allow control of the PWM outputs, determine if the devices are measuring from the internal die or the thermistor inputs, and set the GPIO as inputs or outputs.

Temperature Registers (00h and 01h)

The temperature registers contain the results of temperature measurements. The value of the MSB is 128°C and the value of the LSB is 1°C. Temperature data for thermistor channel 1 is in the temperature channel 1 register (00h). Temperature data for thermistor channel 2 (01h) or the local sensor (selectable by bit D2 in the configuration byte) is in the temperature channel 2 register.

Configuration Byte (02h)

The configuration byte register controls timeout conditions and various PWM signals. The POR state of the configuration byte register is 18h. See Table 4 for configuration byte definitions.

Channel 1 and Channel 2 \overline{OT} Limits (03h and 04h)

Set channel 1 (03h) and channel 2 (04h) temperature thresholds with these two registers. Once the temperature is above the threshold, the \overline{OT} output is asserted low (for the temperature channels that are not masked). The POR state of the channel 1 \overline{OT} limit register is 6Eh, and the POR state of the channel 2 \overline{OT} limit register is 50h.

\overline{OT} Status (05h)

A 1 in D7 or D6 indicates that an \overline{OT} fault has occurred in the corresponding temperature channel. Only reading its contents clears this register. Reading the contents of the register also clears the \overline{OT} output. If the fault is still present on the next temperature measurement cycle, the bits and the \overline{OT} output are set again. The POR state of the \overline{OT} status register is 00h.

\overline{OT} Mask (06h)

Set bit D7 to 1 in the \overline{OT} mask register to prevent the \overline{OT} output from asserting on faults in channel 1. Set bit D6 to 1 to prevent the \overline{OT} output from asserting on faults in channel 2. The POR state of the \overline{OT} mask register is 00h.

PWM Start Duty Cycle (07h and 08h)

The PWM start duty-cycle register determines the PWM duty cycle where the fan starts spinning. Bit D2 in the configuration byte register (MIN DUTY CYCLE) determines the starting duty cycle. If the MIN DUTY CYCLE bit is 1, the duty cycle is the value written to the fan-start duty-cycle register at all temperatures below the fan-start temperature. If the MIN DUTY CYCLE bit is

Dual-Channel Temperature Monitors and Fan-Speed Controllers with Thermistor Inputs

Table 3. Register Map

R/W	ADD	POR STATE	FUNCTION	D7	D6	D5	D4	D3	D2	D1	D0
R	00h	0000 0000	Temperature channel 1	MSB (128°C)	—	—	—	—	—	—	LSB (1°C)
R	01h	0000 0000	Temperature channel 2	MSB (128°C)	—	—	—	—	—	—	LSB (1°C)
R/W	02h	0001 1000	Configuration byte	Standby: 0 = run; 1 = standby	POR: 1 = reset	Timeout: 0 = enabled; 1 = disabled	Fan 1 PWM invert	Fan 2 PWM invert	Min duty cycle: 0 = 0%; 1 = fan-start duty cycle	Temp Ch2 sources: 1 = local; 0 = remote2	Spin-up disable: 0 = enable; 1 = disable
R/W	03h	0110 1110	Temperature channel 1 \overline{OT} limit	MSB	—	—	—	—	—	—	LSB (1°C)
R/W	04h	0101 0000	Temperature channel 2 \overline{OT} limit	MSB	—	—	—	—	—	—	LSB (1°C)
R	05h	00xx xxxx	\overline{OT} status	Channel 1: 1 = fault	Channel 2: 1 = fault	—	—	—	—	—	—
R/W	06h	00xx xxxx	\overline{OT} mask	Channel 1: 1 = masked	Channel 2: 1 = masked	—	—	—	—	—	—
R/W	07h	0110 000x 96 = 40%	PWM1 start duty cycle	MSB (128/240)	—	—	—	—	—	LSB (2/240)	—
R/W	08h	0110 000x 96 = 40%	PWM2 start duty cycle	MSB (128/240)	—	—	—	—	—	LSB (2/240)	—
R/W	09h	1111 000x 240 = 100%	PWM1 max duty cycle	MSB (128/240)	—	—	—	—	—	LSB (2/240)	—
R/W	0Ah	1111 000x 240 = 100%	PWM2 max duty cycle	MSB (128/240)	—	—	—	—	—	LSB (2/240)	—
R/W	0Bh	0000 000x	PWM1 target duty cycle	MSB (128/240)	—	—	—	—	—	LSB (2/240)	—
R/W	0Ch	0000 000x	PWM2 target duty cycle	MSB (128/240)	—	—	—	—	—	LSB (2/240)	—

Dual-Channel Temperature Monitors and Fan-Speed Controllers with Thermistor Inputs

MAX6615/MAX6616

Table 3. Register Map (continued)

R/W	ADD	POR STATE	FUNCTION	D7	D6	D5	D4	D3	D2	D1	D0
R	0Dh	0000 000x	PWM1 instantaneous duty cycle	MSB (128/240)	—	—	—	—	—	LSB (2/240)	—
R	0Eh	0000 000x	PWM2 instantaneous duty cycle	MSB (128/240)	—	—	—	—	—	LSB (2/240)	—
R/W	0Fh	0000 0000	Channel 1 fan-start temperature	MSB	—	—	—	—	—	—	LSB
R/W	10h	0000 0000	Channel 2 fan-start temperature	MSB	—	—	—	—	—	—	LSB
R/W	11h	0000 000x	Fan configuration	Hysteresis: 0 = 5°C, 1 = 10°C	Temp step: 0 = 1°C,	Fan 1: control 1 = Ch 1	Fan 1: control 1 = Ch 2	Fan 2: control 1 = Ch 1	Fan 2: control 1 = Ch 2	—	—
R/W	12h	1011 01xx	Duty-cycle rate of change	Fan 1 MSB	—	Fan 1 LSB	Fan 2 MSB	—	Fan 2 LSB	—	—
R/W	13h	0101 0101	Duty-cycle step size	Fan 1 MSB	—	—	Fan 1 LSB	Fan 2 MSB	—	—	Fan 2 LSB
R/W	14h	010x xxxx	PWM frequency select	Select A	Select B	Select C	—	—	—	—	—
R/W	15h	xx00 000*	GPIO function	—	—	GPIO5: 0 = output; 1 = input	GPIO4: 0 = output; 1 = input	GPIO3: 0 = output; 1 = input	GPIO2: 0 = output; 1 = input	GPIO1: 0 = output; 1 = input	GPIO0: 0 = output; 1 = input
R/W	16h	xx11 111* (Note 1)	GPIO value	—	—	GPIO5	GPIO4	GPIO3	GPIO2	GPIO1	GPIO0
R/W	17h	0000 0000	Thermistor offset register	Th1 MSB (sign)	—	—	Th1 LSB (2°C)	Th2 MSB (sign)	—	—	Th2 LSB (2°C)
R	18h	1111 1111	Tach1 value register	—	—	—	—	—	—	—	—
R	19h	1111 1111	Tach2 value register	—	—	—	—	—	—	—	—
R/W	1Ah	1111 1111	Tach1 limit register	—	—	—	—	—	—	—	—
R/W	1Bh	1111 1111	Tach2 limit register	—	—	—	—	—	—	—	—

Dual-Channel Temperature Monitors and Fan-Speed Controllers with Thermistor Inputs

Table 3. Register Map (continued)

R/W	ADD	POR STATE	FUNCTION	D7	D6	D5	D4	D3	D2	D1	D0
R/W	1Ch	0000 0000	Fan status byte	1 = fan 1 failure	1 = fan 2 failure	1 = disabled fan 1 tach	1 = disabled fan 2 tach	1 = measure fan 1 when it is full speed	1 = measure fan 2 when it is full speed	1 = mask FAN_FAIL pin	1 = fan 1 fail sets fan 2 100%
R	1Eh	0000 0000	Channel 1 temp LSBs	MSB (1/2°C)	—	LSB (1/8°C)	—	—	—	—	—
R	1Fh	0000 0000	Channel 2 temp LSBs	MSB (1/2°C)	—	LSB (1/8°C)	—	—	—	—	—
R	FDh	0000 0001	Read device revision	0	0	0	0	0	0	0	1
R	FEh	0110 1000	Read device ID	0	1	1	0	1	0	0	0
R	FFh	0100 1101	Read manufacturer ID	0	1	0	0	1	1	0	1

*GPIO0 POR values are set by PRESET.

Table 4. Configuration Byte Definition (02h)

BIT	NAME	POR STATE	FUNCTION
7	RUN/STANDBY	0	Set to zero for normal operation. Set to 1 to suspend conversions and PWM outputs.
6	POR	0	Set to 1 to perform reset of all device registers.
5	TIMEOUT	0	Set TIMEOUT to zero to enable SMBus timeout for prevention of bus lockup. Set to 1 to disable this function.
4	FAN1 PWM INVERT	1	Set fan PWM invert to zero to force PWM1 low when the duty cycle is 100%. Set to 1 to force PWM1 high when the duty cycle is 100%.
3	FAN2 PWM INVERT	1	Set fan PWM invert to zero to force PWM2 low when the duty cycle is 100%. Set to 1 to force PWM2 high when the duty cycle is 100%.
2	MIN DUTY CYCLE	0	Set min duty cycle to zero for a 0% duty cycle when the measured temperature is below the fan-temperature threshold in automatic mode. When the temperature equals the fan-temperature threshold, the duty cycle is the value in the fan-start duty-cycle register, and it increases with increasing temperature. Set min duty cycle to 1 to force the PWM duty cycle to the value in the fan-start duty-cycle register when the measured temperature is below the fan-temperature threshold. As the temperature increases above the temperature threshold, the duty cycle increases as programmed.
1	TEMPERATURE SOURCE SELECT	0	Selects either local or remote 2 as the source for temperature channel 2 register data. When D1 = 0, the MAX6615/MAX6616 measure remote 2 and when D1 = 1, the MAX6615/MAX6616 measure the internal die temperature.
0	SPIN-UP DISABLE	0	Set spin-up disable to 1 to disable spin-up. Set to zero for normal fan spin-up.

Dual-Channel Temperature Monitors and Fan-Speed Controllers with Thermistor Inputs

zero, the duty cycle is zero below the fan-start temperature and has this value when the fan-start temperature is reached. A value of 240 represents 100% duty cycle. Writing any value greater than 240 causes the fan speed to be set to 100%. The POR state of the fan-start duty-cycle register is 96h, 40%.

PWMOUT Max Duty Cycle (09h and 0Ah)

The PWM maximum duty-cycle register sets the maximum allowable PWM duty cycle between 2/240 (0.83% duty cycle) and 240/240 (100% duty cycle). Any values greater than 240 are recognized as 100% maximum duty cycle. The POR state of the PWM maximum duty-cycle register is F0h, 100%. In manual-control mode, this register is ignored.

PWM Target Duty Cycle (0Bh and 0Ch)

In automatic fan-control mode, this register contains the present value of the target PWM duty cycle, as determined by the measured temperature and the duty-cycle step size. The actual duty cycle requires time before it equals the target duty cycle if the duty-cycle rate-of-change register is set to a value other than zero. In manual fan-control mode, write the desired value of the PWM duty cycle directly into this register. The POR state of the fan-target duty-cycle register is 00h.

PWM1 Instantaneous Duty Cycle, PWM2 Instantaneous Duty Cycle (0Dh, 0Eh)

These registers always contain the duty cycle of the PWM signals presented at the PWM output.

The POR state of the PWM instantaneous duty-cycle register is 00h.

Channel 1 and Channel 2 Fan-Start Temperature (0Fh and 10h)

These registers contain the temperatures at which fan control begins (in automatic mode). See the *Automatic PWM Duty-Cycle Control* section for details on setting the fan-start thresholds. The POR state of the channel 1 and channel 2 fan-start temperature registers is 00h.

Fan Configuration (11h)

The fan-configuration register controls the hysteresis level, temperature step size, and whether the remote or local diode controls the PWM2 signal (see Table 3). Set bit D7 of the fan-configuration register to zero to set the hysteresis value to 5°C. Set bit D7 to 1 to set the hysteresis value to 10°C. Set bit D6 to zero to set the fan-control temperature step size to 1°C. Set bit D6 to 1 to set the fan-control temperature step size to +2°C. Bits D5 to D2 select which PWM_ channel 1 or channel 2 controls (see Table 3). If both are selected for a given PWM_, the highest PWM value is used. If neither is selected, the fan is controlled by the value written to the

fan-target duty-cycle register. Also in this mode, the value written to the target duty-cycle register is not limited by the value in the maximum duty-cycle register. It is, however, clipped to 240 if a value above 240 is written. The POR state of the fan-configuration register is 00h.

Duty-Cycle Rate of Change (12h)

Bits D7, D6, and D5 (channel 1) and D4, D3, and D2 (channel 2) of the duty-cycle rate-of-change register set the time between increments of the duty cycle. Each increment is 2/240 of the duty cycle (see Table 5). This allows the time from 33% to 100% duty cycle to be adjusted from 5s to 320s. The rate-of-change control is always active in manual mode. To make instant changes, set bits D7, D6, and D5 (channel 1) or D4, D3, and D2 (channel 2) = 000. The POR state of the duty-cycle rate-of-change register is B4h (1s between increments).

Table 5. Setting the Time Between Duty-Cycle Increments

D7:D5, D4:D2	TIME BETWEEN INCREMENTS (s)	TIME FROM 33% TO 100% (s)
000	0	0
001	0.0625	5
010	0.125	10
011	0.25	20
100	0.5	40
101	1	80
110	2	160
111	4	320

Table 6. Setting the Duty-Cycle Step Size

D7:D4, D3:D0	CHANGE IN DUTY CYCLE PER TEMPERATURE STEP	TEMPERATURE RANGE FOR FAN CONTROL (1°C STEP, 33% TO 100%)
0000	0	0
0001	2/240	80
0010	4/240	40
0011	6/240	27
0100	8/240	20
0101	10/240	16
...
1000	16/240	10
...
1111	31/240	5

Dual-Channel Temperature Monitors and Fan-Speed Controllers with Thermistor Inputs

Table 7. PWM Frequency Select

PWM FREQUENCY (Hz)	SELECT A	SELECT B	SELECT C
20	0	0	0
33	0	1	0
50	1	0	0
100	1	1	0
35k	X	X	1

Note: At 35kHz, duty-cycle resolution is decreased from a resolution of 2/240 to 4/240.

Duty-Cycle Step Size (13h)

Bits D7–D4 (channel 1) and bits D3–D0 (channel 2) of the duty-cycle step-size register change the size of the duty-cycle change for each temperature step. The POR state of the duty-cycle step-size register is 55h (see Table 6).

PWM Frequency Select (14h)

Set bits D7, D6, and D5 (select A, B, and C) in the PWM frequency-select register to control the PWM frequency (see Table 7). The POR state of the PWM frequency-select register is 40h, 33Hz. The lower frequencies are usually used when driving the fan's power-supply pin as in the *Typical Application Circuit*, with 33Hz being the most common choice. The 35kHz frequency setting is used for controlling fans that have logic-level PWM input pins for speed control. The minimum duty-cycle resolution is decreased from 2/240 to 4/240 at the 35kHz frequency setting. For example, a result that would return a value of 6/240 is truncated to 4/240.

GPIO Function Register (15h) (MAX6616)

The GPIO function register (15h) sets the GPIO states. Write a zero to set a GPIO as an output. Write a 1 to set a GPIO as an input.

GPIO Value Register (16h) (MAX6616)

The GPIO value register (16h) contains the state of each GPIO input when a GPIO is configured as an input. When configured as an output, write a 1 or zero to set the value of the GPIO output.

Thermistor Offset Register (17h)

The thermistor offset register contains the offset for both of the thermistors in two's complement. Bits D7, D6, D5, and D4 set the offset for temperature channel 1. Bits D3, D2, D1, and D0 set the offset for temperature channel 2. The values in this register allow the thermistor temperature readings to be shifted to help compensate for different thermistor characteristics or different values of R_{EXT} and apply to thermistor measurements only.

The MSB is the sign bit and the LSB is 2°C. The POR state for this register is 00h.

Tachometer Value Registers (18h and 19h)

The tachometer value registers contain the tachometer count values for each fan. The MAX6615/MAX6616 measure the tachometer signal every 67s. It counts the number of clock cycles between two tachometer pulses and stores the value in the corresponding channel register. The POR state of this register is 00h.

Tachometer Limit Registers (1Ah and 1Bh)

The tachometer limit registers contain the tachometer limits for each fan. If the value in the tach1 value register (18h) ever exceeds the value stored in 1Ah, a channel 1 fan failure is detected. If the value in the Tach2 value register (19h) ever exceeds the value stored in 1Bh, a channel 2 fan failure is detected. The POR state of these registers is 00h.

Fan Configuration/Status Register (1Ch)

The fan configuration/status register contains the status and tachometer control bits for both fans. Bits D7 and D6 indicate whether a fan has failed the maximum tachometer limits in registers 1Ah and 1Bh. Setting bits D5 and D4 disables the tachometer for each fan. The speed is not measured when these bits are set. Setting bits D3 and D2 measure the fan speed only during spin-up or when it reaches 100% duty cycle. Bit D1 is the $\overline{\text{FAN_FAIL}}$ output mask. Bit D0 is the $\overline{\text{FAN_FAIL}}$ cross drive enable. Setting this bit enables fan 2 to go to full speed when fan 1 fails or vice versa.

Extended Temperature Registers (1Eh and 1Fh)

The extended temperature registers contain the low-byte results of temperature measurements. The value of the MSB is 0.5°C and the value of D5 is 0.125°C. The POR states of these registers are 00h.

Dual-Channel Temperature Monitors and Fan-Speed Controllers with Thermistor Inputs

MAX6615/MAX6616

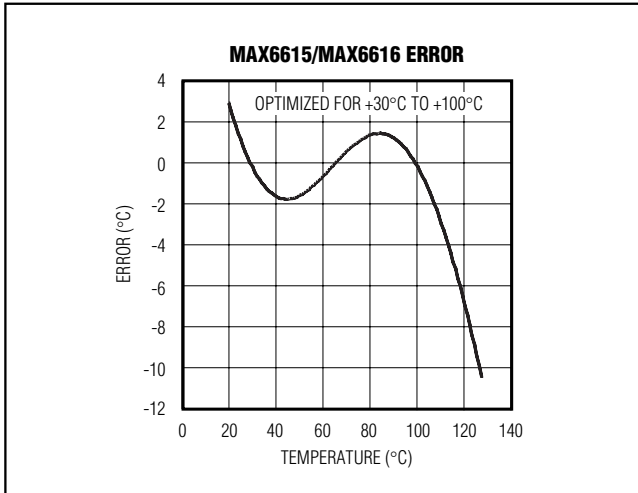

Figure 9. Data Error vs. Temperature Using a Betatherm 10K3A1 Thermistor

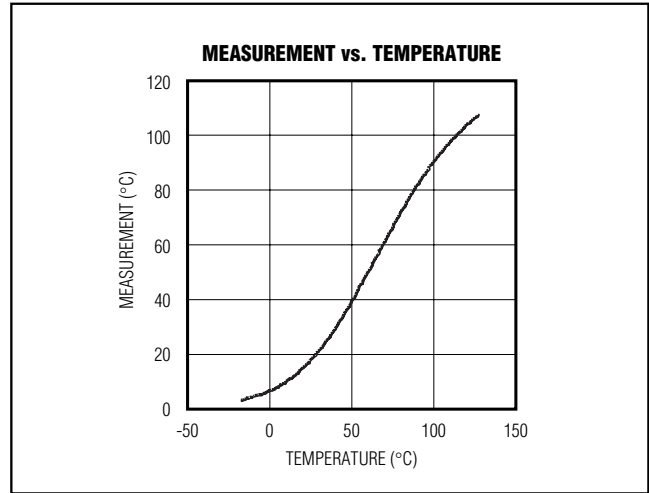

Figure 10. Measured Temperature vs. Actual Temperature

Applications Information

Thermistor Considerations

NTC thermistors are resistive temperature sensors whose resistance decreases with increasing temperature. They are available in a wide variety of packages that are useful in difficult applications such as measurement of air or liquid temperature. Some can operate over temperature ranges beyond that of most ICs. The relationship between temperature and resistance in an NTC thermistor is very nonlinear and can be described by the following approximation:

$$\frac{1}{T} = A + B \ln(R) + C[\ln(R)]^3$$

where T is absolute temperature in Kelvin, R is the thermistor's resistance, and A, B, and C are coefficients that vary with manufacturer and material characteristics.

The highly nonlinear relationship between temperature and resistance in an NTC thermistor makes it somewhat more difficult to use than a digital-output temperature-sensor IC. However, by connecting the thermistor in series with a properly chosen resistor and using the MAX6615/MAX6616 to measure the voltage across the resistor, a reasonably linear transfer function can be obtained over a limited temperature range. Accuracy increases over smaller temperature ranges.

Figures 9 and 10 show a good relationship between temperature and data. This data was taken using a popular thermistor model, the Betatherm 10K3A1, with $R_{EXT} = 1.6k\Omega$. Using these values produces data with

good conformance to real temperature over a range of about +30°C to +100°C. Different combinations of thermistors and R_{EXT} result in different curves.

ADC Noise Filtering

The integrating ADC has inherently good noise rejection, especially at low-frequency signals such as 60Hz/120Hz power-supply hum. Lay out the PC board carefully with proper external noise filtering for high-accuracy thermistor measurements in electrically noisy environments.

Filter high-frequency electromagnetic interference (EMI) at TH_ and REF with an external 100pF capacitor connected between the two inputs. This capacitor can be increased to about 2000pF (max), including cable capacitance. A capacitance higher than 2000pF introduces errors due to the rise time of the switched current source.

Chip Information

PROCESS: BiCMOS

Dual-Channel Temperature Monitors and Fan-Speed Controllers with Thermistor Inputs

Pin Configurations

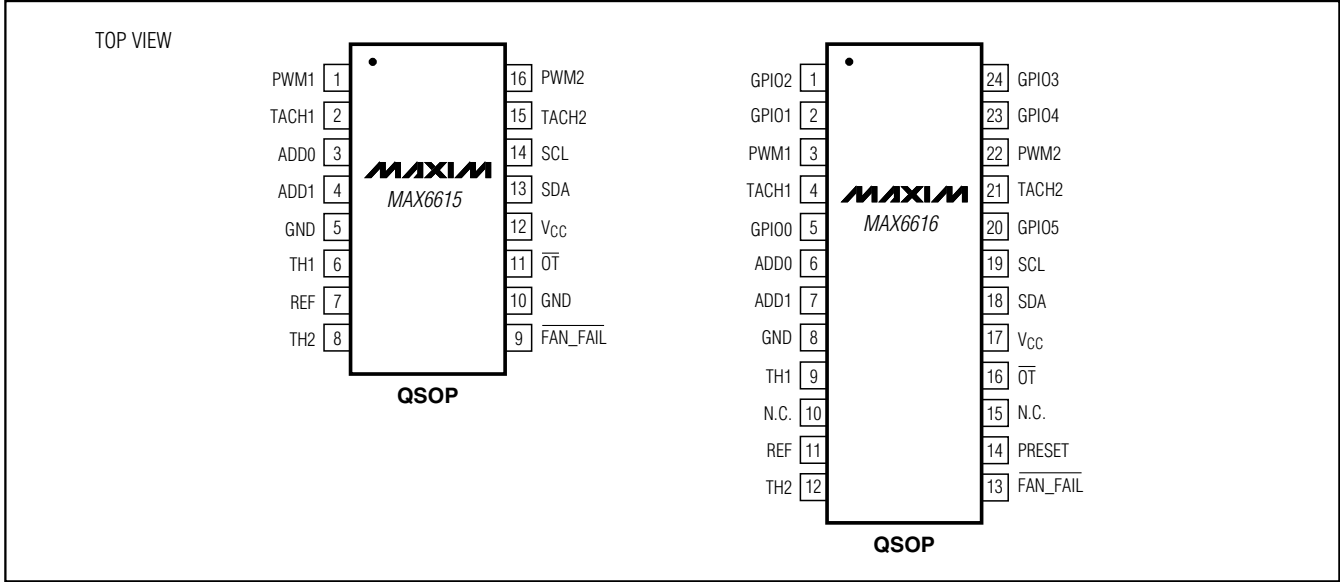

Typical Application Circuits

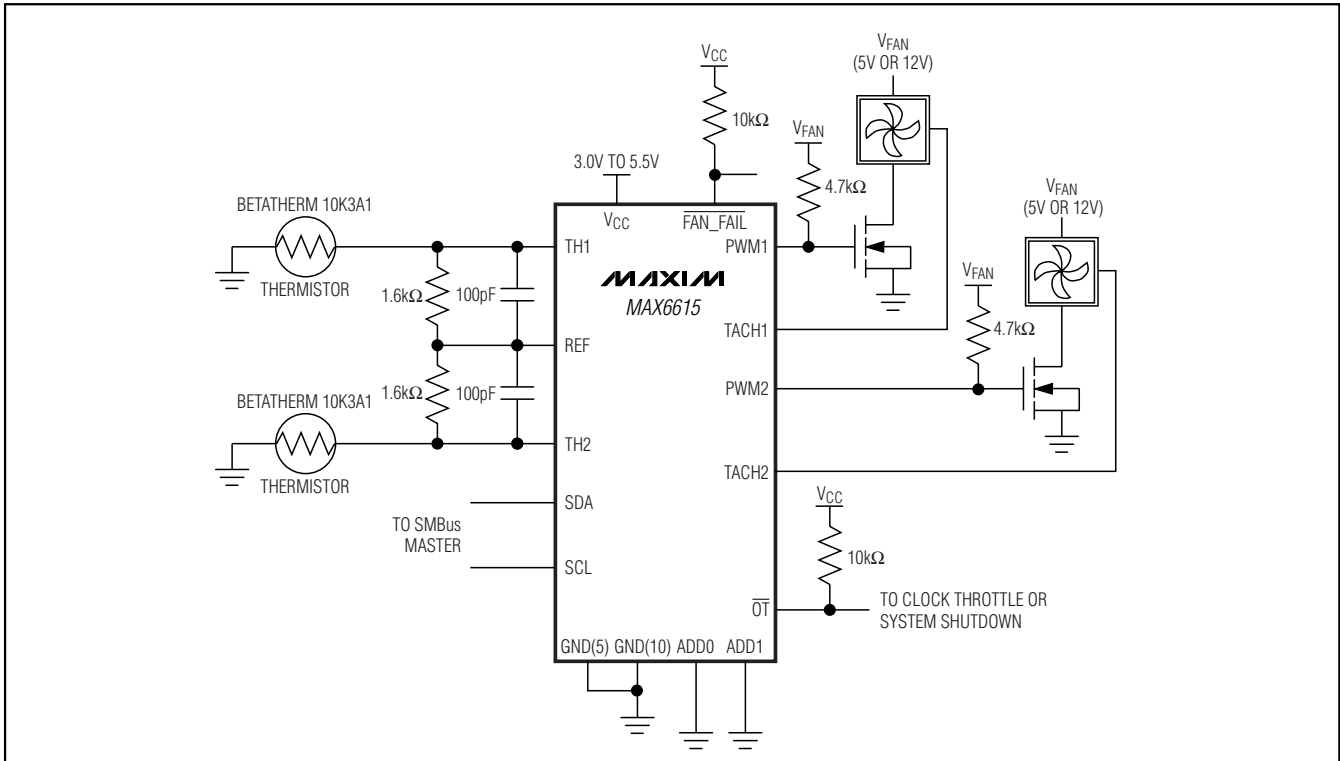

Dual-Channel Temperature Monitors and Fan-Speed Controllers with Thermistor Inputs

Typical Application Circuits (continued)

MAX6615/MAX6616

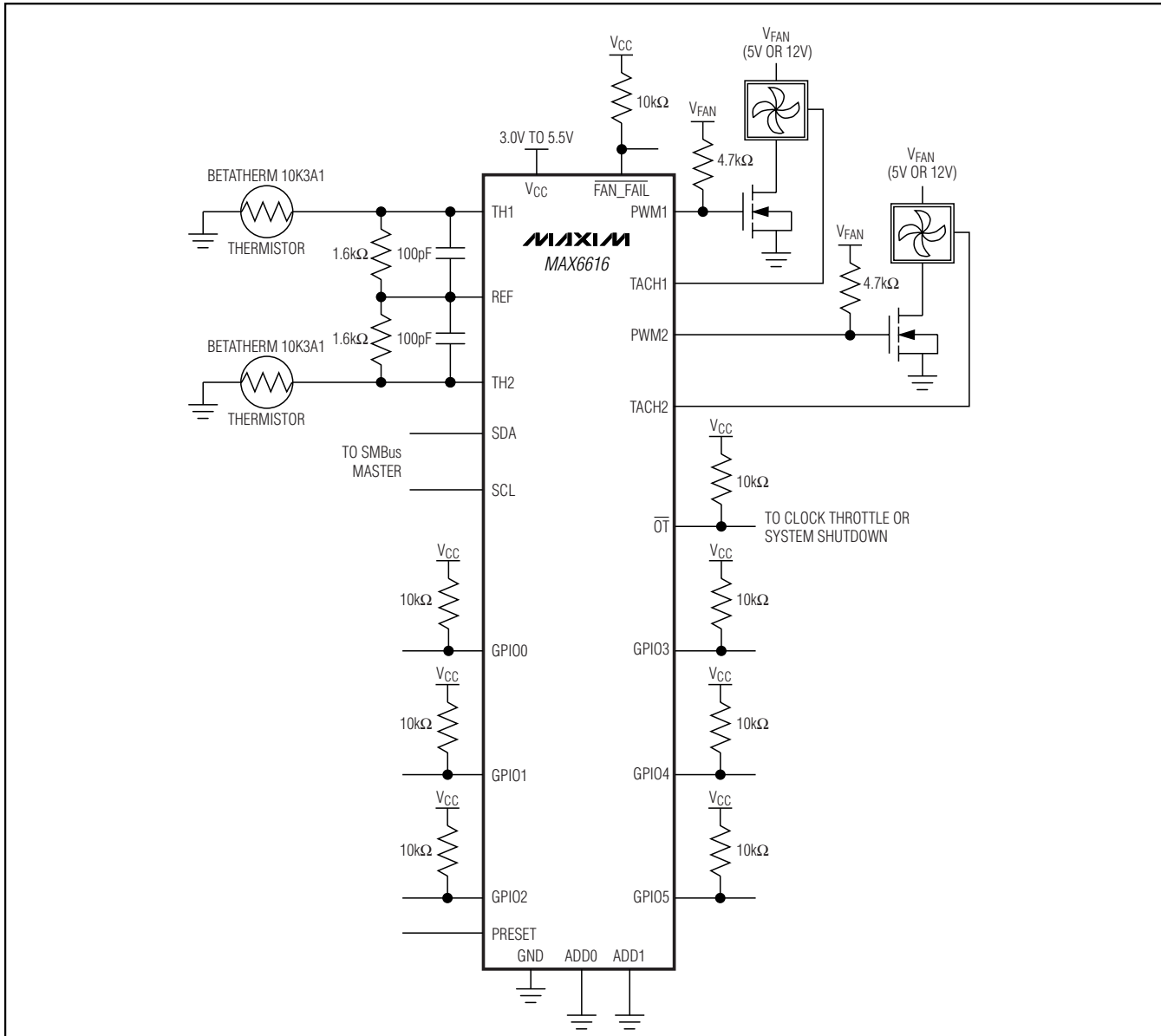

Dual-Channel Temperature Monitors and Fan-Speed Controllers with Thermistor Inputs

Package Information

(The package drawing(s) in this data sheet may not reflect the most current specifications. For the latest package outline information, go to www.maxim-ic.com/packages.)

DIM	INCHES		MILLIMETERS	
	MIN	MAX	MIN	MAX
A	.061	.068	1.55	1.73
A1	.004	.0098	0.102	0.249
A2	.055	.061	1.40	1.55
B	.008	.012	0.20	0.30
C	.0075	.0098	0.191	0.249
D	SEE VARIATIONS			
E	.150	.157	3.81	3.99
e	.025 BSC		0.635 BSC	
H	.230	.244	5.84	6.20
h	.010	.016	0.25	0.41
L	.016	.035	0.41	0.89
N	SEE VARIATIONS			
α	0°	8°	0°	8°

DIM	INCHES		MILLIMETERS		N
	MIN.	MAX.	MIN.	MAX.	
D	.189	.196	4.80	4.98	16 AB
S	.0020	.0070	0.05	0.18	
D	.337	.344	8.56	8.74	20 AD
S	.0500	.0550	1.270	1.397	
D	.337	.344	8.56	8.74	24 AE
S	.0250	.0300	0.635	0.762	
D	.386	.393	9.80	9.98	28 AF
S	.0250	.0300	0.635	0.762	

NOTES:
 1). D & E DO NOT INCLUDE MOLD FLASH OR PROTRUSIONS.
 2). MOLD FLASH OR PROTRUSIONS NOT TO EXCEED .006" PER SIDE.
 3). CONTROLLING DIMENSIONS: INCHES.
 4). MEETS JEDEC MO137.

DALLAS SEMICONDUCTOR **MAXIM**
 PROPRIETARY INFORMATION
 TITLE: PACKAGE OUTLINE, QSOP .150", .025" LEAD PITCH
 APPROVAL: _____ DOCUMENT CONTROL NO. 21-0055 REV. E 1/1

QSOP16PS

Maxim cannot assume responsibility for use of any circuitry other than circuitry entirely embodied in a Maxim product. No circuit patent licenses are implied. Maxim reserves the right to change the circuitry and specifications without notice at any time.

20 Maxim Integrated Products, 120 San Gabriel Drive, Sunnyvale, CA 94086 408-737-7600

© 2005 Maxim Integrated Products Printed USA **MAXIM** is a registered trademark of Maxim Integrated Products, Inc.