

FEATURES

- Oversampled successive approximation (SAR) architecture**
- High performance ac and dc accuracy, low power**
 - 115.5 dB dynamic range, 32 kSPS (AD7767-2)
 - 112.5 dB dynamic range, 64 kSPS (AD7767-1)
 - 109.5 dB dynamic range, 128 kSPS (AD7767)
 - 118 dB THD
- Exceptionally low power**
 - 8.5 mW, 32 kSPS (AD7767-2)
 - 10.5 mW, 64 kSPS (AD7767-1)
 - 15 mW, 128 kSPS (AD7767)
- High dc accuracy**
 - 24 bits, no missing codes (NMC)
 - INL: ± 3 ppm (typical), ± 7.6 ppm (maximum)
- Low temperature drift**
 - Zero error drift: 15 nV/°C
 - Gain error drift: 0.0075% FS
- On-chip low-pass FIR filter**
 - Linear phase response
 - Pass-band ripple: ± 0.005 dB
 - Stop-band attenuation: 100 dB
- 2.5 V supply with 1.8 V/2.5 V/3 V/3.6 V logic interface options**
- Flexible interfacing options**
 - Synchronization of multiple devices
 - Daisy chain capability
 - Power-down function
- Temperature range: -40°C to +105°C**

APPLICATIONS

- Low power PCI/USB data acquisition systems
- Low power wireless acquisition systems
- Vibration analysis
- Instrumentation
- High precision medical acquisition

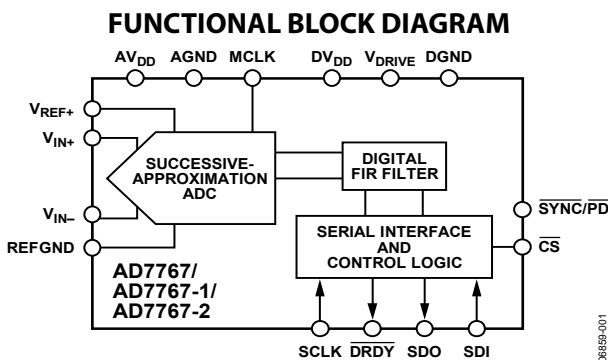

Figure 1.

GENERAL DESCRIPTION

The AD7767/AD7767-1/AD7767-2 are high performance 24-bit oversampled SAR analog-to-digital converters (ADC). The AD7767/AD7767-1/AD7767-2 combine the benefits of a large dynamic range and input bandwidth, consuming 15 mW, 10.5 mW, and 8.5 mW power, respectively, all contained in a 16-lead TSSOP package.

Ideal for ultralow power data acquisition (such as PCI- and USB-based systems), the AD7767/AD7767-1/AD7767-2 provide 24-bit resolution. The combination of exceptional SNR, wide dynamic range, and outstanding dc accuracy make the AD7767/AD7767-1/AD7767-2 ideally suited for measuring small signal changes over a wide dynamic range. This is particularly suitable for applications where small changes on the input are measured on larger ac or dc signals. In such an application, the AD7767/AD7767-1/AD7767-2 accurately gather both ac and dc information.

The AD7767/AD7767-1/AD7767-2 include an on-board digital filter (complete with linear phase response) that acts to eliminate out-of-band noise by filtering the oversampled input voltage. The oversampled architecture also reduces front-end antialias requirements. Other features of the AD7767 include a SYNC/PD (synchronization/power-down) pin, allowing the synchronization of multiple AD7767 devices. The addition of an SDI pin provides the option of daisy chaining multiple AD7767 devices.

The AD7767/AD7767-1/AD7767-2 operate from a 2.5 V supply using a 5 V reference. The devices operate from -40°C to +105°C.

RELATED DEVICES

Table 1. 24-Bit Analog-to-Digital Converters

Part No.	Description
AD7760	2.5 MSPS, 100 dB dynamic range ¹ , on-board differential amp and reference buffer, parallel, variable decimation
AD7762/ AD7763	625 kSPS, 109 dB dynamic range ¹ , on-board differential amp and reference buffer, parallel/serial, variable decimation
AD7764	312 kSPS, 109 dB dynamic range ¹ , on-board differential amp and reference buffer, variable decimation (pin)
AD7765	156 kSPS, 112 dB dynamic range ¹ , on-board differential amp and reference buffer, variable decimation (pin)
AD7766	128 kSPS, 109.5 dB ¹ , 15 mW, 16-bit INL, serial interface
AD7766-1	64 kSPS 112.5 dB ¹ , 10.5 mW, 16-bit INL, serial interface
AD7766-2	32 kSPS, 115.5 dB ¹ , 8.5 mW, 16-bit INL, serial interface

¹ Dynamic range at maximum output data rate.

Rev. 0

Information furnished by Analog Devices is believed to be accurate and reliable. However, no responsibility is assumed by Analog Devices for its use, nor for any infringements of patents or other rights of third parties that may result from its use. Specifications subject to change without notice. No license is granted by implication or otherwise under any patent or patent rights of Analog Devices. Trademarks and registered trademarks are the property of their respective owners.

TABLE OF CONTENTS

Features	1	AD7767 Interface	17
Applications.....	1	Initial Power-Up	17
Functional Block Diagram	1	Reading Data.....	17
General Description	1	Power-Down, Reset, and Synchronization	17
Revision History	2	Daisy Chaining	18
Specifications.....	3	Reading Data in Daisy Chain Mode	18
Timing Specifications	5	Choosing the SCLK Frequency	18
Timing Diagrams.....	6	Daisy Chain Mode Configuration and Timing Diagrams....	19
Absolute Maximum Ratings.....	8	Driving the AD7767	20
ESD Caution.....	8	Differential Signal Source	20
Pin Configuration and Function Descriptions.....	9	Single-Ended Signal Source	20
Typical Performance Characteristics	10	Antialiasing	21
Terminology	14	Power Dissipation.....	21
Theory of Operation	15	V _{REF+} Input Signal	22
AD7767/AD7767-1/AD7767-2 Transfer Function.....	15	Multiplexing Analog Input Channels	22
Converter Operation.....	15	Outline Dimensions	23
Analog Input Structure.....	16	Ordering Guide	23
Supply and Reference Voltages	16		

REVISION HISTORY

8/07—Revision 0: Initial Version

SPECIFICATIONS

$V_{DD} = DV_{DD} = 2.5\text{ V} \pm 5\%$, $V_{DRIVE} = 1.8\text{ V}$ to 3.6 V , $V_{REF} = 5\text{ V}$, $MCLK = 1\text{ MHz}$, common-mode input = $V_{REF}/2$, $T_A = -40^\circ\text{C}$ to $+105^\circ\text{C}$, unless otherwise noted.

Table 2.

Parameter	Test Conditions/Comments	Min	Typ	Max	Unit
OUTPUT DATA RATE					
AD7767	Decimate by 8			128	kHz
AD7767-1	Decimate by 16			64	kHz
AD7767-2	Decimate by 32			32	kHz
ANALOG INPUT ¹					
Differential Input Voltage	$V_{IN+} - V_{IN-}$			$\pm V_{REF}$	V p-p
Absolute Input Voltage	V_{IN+}	-0.1		$+V_{REF} + 0.1$	V
	V_{IN-}	-0.1		$+V_{REF} + 0.1$	V
Common-Mode Input Voltage		$V_{REF}/2 - 5\%$	$V_{REF}/2$	$V_{REF}/2 + 5\%$	V
Input Capacitance			22		pF
DYNAMIC PERFORMANCE					
AD7767	Decimate by 8, ODR = 128 kHz				
Dynamic Range ²	Shorted inputs	108	109.5		dB
Signal-to-Noise Ratio (SNR) ²	Full-scale input amplitude, 1 kHz tone	107	108.5		dB
Spurious Free Dynamic Range (SFDR) ²	Full-scale input amplitude, 1 kHz tone		-128	-116	dB
Total Harmonic Distortion (THD) ²	Full-scale input amplitude, 1 kHz tone		-118	-105	dB
Intermodulation Distortion (IMD) ²	Tone A = 49.7 kHz, Tone B = 53 kHz				
	Second-order terms		-133		dB
	Third-order terms		-109		dB
AD7767-1	Decimate by 16, ODR = 64 kHz				
Dynamic Range ²	Shorted inputs	111	112.5		dB
Signal-to-Noise Ratio (SNR) ²	Full-scale input amplitude, 1 kHz tone	110	111.5		dB
Spurious Free Dynamic Range (SFDR) ²	Full-scale input amplitude, 1 kHz tone		-128	-116	dB
Total Harmonic Distortion (THD) ²	Full-scale input amplitude, 1 kHz tone		-118	-105	dB
Intermodulation Distortion (IMD) ²	Tone A = 24.7 kHz, Tone B = 25.3 kHz				dB
	Second-order terms		-133		dB
	Third-order terms		-108		dB
AD7767-2	Decimate by 32, ODR = 32 kHz				
Dynamic Range ²	Shorted inputs	114	115.5		dB
Signal-to-Noise Ratio (SNR) ²	Full-scale input amplitude, 1 kHz tone	112	113.5		dB
Spurious Free Dynamic Range (SFDR) ²	Full-scale input amplitude, 1 kHz tone		-128	-116	dB
Total Harmonic Distortion (THD) ²	Full-scale input amplitude, 1 kHz tone		-118	-105	dB
Intermodulation Distortion (IMD) ²	Tone A = 11.7 kHz, Tone B = 12.3 kHz				dB
	Second-order terms		-137		dB
	Third-order terms		-108		dB
DC ACCURACY ¹	For all devices				
Resolution	No missing codes	24			Bits
Differential Nonlinearity ²	Guaranteed monotonic to 24 bits				
Integral Nonlinearity ²	18-bit linearity		3	± 7.6	ppm
Zero Error ²			20		μV
Gain Error ²			0.0075	0.075	% FS
Zero Error Drift ²			15		nV/ $^\circ\text{C}$
Gain Error Drift ²			0.4		ppm/ $^\circ\text{C}$
Common-Mode Rejection Ratio ²	50 Hz tone		-110		dB

AD7767

Parameter	Test Conditions/Comments	Min	Typ	Max	Unit	
DIGITAL FILTER RESPONSE ¹						
Group Delay	Complete settling		37/ODR		μs	
Settling Time (Latency)			74/ODR		μs	
Pass-Band Ripple				±0.005		dB
Pass Band				0.453 × ODR		Hz
−3 dB Bandwidth				0.49 × ODR		Hz
Stop Band Frequency				0.547 × ODR		Hz
Stop-Band Attenuation			100			dB
REFERENCE INPUT ¹						
V _{REF+} Input Voltage		+2.4		2 × AV _{DD}	V	
DIGITAL INPUTS (Logic Levels) ¹						
V _{IL}		−0.3		0.3 × V _{DRIVE}	V	
V _{IH}		0.7 × V _{DRIVE}		V _{DRIVE} + 0.3	V	
Input Leakage Current				±1	μA/pin	
Input Capacitance			5		pF	
Master Clock Rate				1.024	MHz	
Serial Clock Rate				1/t _s	Hz	
DIGITAL OUTPUTS ¹						
Data Format	Serial 24 bits, twos complement (MSB first)					
V _{OL}	I _{SINK} = +500 μA			0.4	V	
V _{OH}	I _{SOURCE} = −500 μA	V _{DRIVE} − 0.3			V	
POWER REQUIREMENTS ¹						
AV _{DD}	± 5%		+2.5		V	
DV _{DD}	± 5%		+2.5		V	
V _{DRIVE}		+1.7	+2.5	+3.6	V	
CURRENT SPECIFICATIONS	MCLK = 1.024 MHz					
AD7767 (Operational Current)	128 kHz output data rate					
AI _{DD}			1.3	1.5	mA	
DI _{DD}			3.9	4.8	mA	
I _{REF}			0.35	0.425	mA	
AD7767-1 (Operational Current)	64 kHz output data rate					
AI _{DD}			1.3	1.5	mA	
DI _{DD}			2.2	2.85	mA	
I _{REF}			0.35	0.425	mA	
AD7767-2 (Operational Current)	32 kHz output data rate					
AI _{DD}			1.3	1.5	mA	
DI _{DD}			1.37	1.86	mA	
I _{REF}			0.35	0.425	mA	
Static Current (MCLK Stopped)	For all devices					
AI _{DD}			0.9	1	mA	
DI _{DD}			1	93	μA	
Power-Down Mode Current	For all devices					
AI _{DD}			0.1	6	μA	
DI _{DD}			1	93	μA	
POWER DISSIPATION	MCLK = 1.024 MHz					
AD7767 (Operational Power)	128 kHz output data rate		15	18	mW	
AD7767-1 (Operational Power)	64 kHz output data rate		10.5	13	mW	
AD7767-2 (Operational Power)	32 kHz output data rate		8.5	10.5	mW	

¹ Specifications for all devices, AD7767, AD7767-1, and AD7767-2.

² See the Terminology section.

TIMING SPECIFICATIONS

$AV_{DD} = DV_{DD} = 2.5\text{ V} \pm 5\%$, $V_{DRIVE} = 1.7\text{ V}$ to 3.6 V , $V_{REF} = 5\text{ V}$, common-mode input = $V_{REF}/2$, $T_A = -40^\circ\text{C}$ (T_{MIN}) to $+105^\circ\text{C}$ (T_{MAX}), unless otherwise noted ¹

Table 3.

Parameter	Limit at T_{MIN} , T_{MAX}	Unit	Description
DRDY Operation			
t_1	510	ns typ	MCLK rising edge to \overline{DRDY} falling edge
t_2^2	100	ns min	MCLK high pulse width
t_3	900	ns max	MCLK low pulse width
t_4	265	ns typ	MCLK rising edge to \overline{DRDY} rising edge (AD7767)
	128	ns typ	MCLK rising edge to \overline{DRDY} rising edge (AD7767-1)
	71	ns typ	MCLK rising edge to \overline{DRDY} rising edge (AD7767-2)
t_5	294	ns typ	\overline{DRDY} pulse width (AD7767)
	435	ns typ	\overline{DRDY} pulse width (AD7767-1)
	492	ns typ	\overline{DRDY} pulse width (AD7767-2)
t_{READ}^3	$t_{\overline{DRDY}} - t_5$	ns typ	\overline{DRDY} low period, read data during this period
$t_{\overline{DRDY}}^3$	$n \times 8 \times t_{MCLK}$	ns typ	\overline{DRDY} period
Read Operation			
t_6	0	ns min	\overline{DRDY} falling edge to \overline{CS} setup time
t_7	6	ns max	\overline{CS} falling edge to SDO three-state disabled
t_8	60	ns max	Data access time after SCLK falling edge ($V_{DRIVE} = 1.7\text{ V}$)
	50	ns max	Data access time after SCLK falling edge ($V_{DRIVE} = 2.3\text{ V}$)
	25	ns max	Data access time after SCLK falling edge ($V_{DRIVE} = 2.7\text{ V}$)
	24	ns max	Data access time after SCLK falling edge ($V_{DRIVE} = 3.0\text{ V}$)
t_9	10	ns min	SCLK falling edge to data valid hold time ($V_{DRIVE} = 3.6\text{ V}$)
t_{10}	10	ns min	SCLK high pulse width
t_{11}	10	ns min	SCLK low pulse width
t_{SCLK}	$1/t_8$	min	Minimum SCLK period
t_{12}	6	ns max	Bus relinquish time after \overline{CS} rising edge
t_{13}	0	ns min	\overline{CS} rising edge to \overline{DRDY} rising edge
Read Operation with \overline{CS} Low			
t_{14}	0	ns min	\overline{DRDY} falling edge to data valid setup time
t_{15}	0	ns max	\overline{DRDY} rising edge to data valid hold time
Daisy Chain Operation			
t_{16}	1	ns min	SDI valid to SCLK falling edge setup time
t_{17}	2	ns max	SCLK falling edge to SDI valid hold time
SYNC/PD Operation			
t_{18}	1	ns typ	$\overline{SYNC}/\overline{PD}$ falling edge to MCLK rising edge
t_{19}	20	ns typ	MCLK rising edge to \overline{DRDY} rising edge going into $\overline{SYNC}/\overline{PD}$
t_{20}	1	ns min	$\overline{SYNC}/\overline{PD}$ rising edge to MCLK rising edge
t_{21}	510	ns typ	MCLK rising edge to \overline{DRDY} falling edge coming out of $\overline{SYNC}/\overline{PD}$
$t_{SETTLING}^3$	$592 \times (n + 2)$	t_{MCLK}	Filter settling time after a reset or power-down

¹ Sample tested during initial release to ensure compliance. All input signals are specified with $t_r = t_f = 5\text{ ns}$ (10% to 90% of DV_{DD}) and timed from a voltage level of 1.7 V.

² t_2 and t_3 allow a ~90% to 10% duty cycle to be used for the MCLK input where the minimum is 10% for the clock high time and 90% for MCLK low time. The maximum MCLK frequency is 1.024 MHz.

³ $n = 1$ for AD7767, $n = 2$ for the AD7767-1, $n = 4$ for the AD7767-2.

TIMING DIAGRAMS

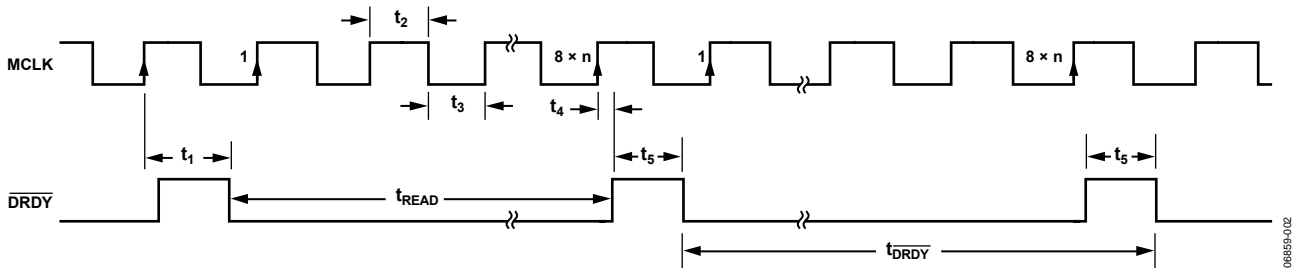

Figure 2. \overline{DRDY} vs. MCLK Timing Diagram, $n = 1$ for AD7767 (Decimate by 8), $n = 2$ for AD7767-1 (Decimate by 16), $n = 4$ for AD7767-2 (Decimate by 32)

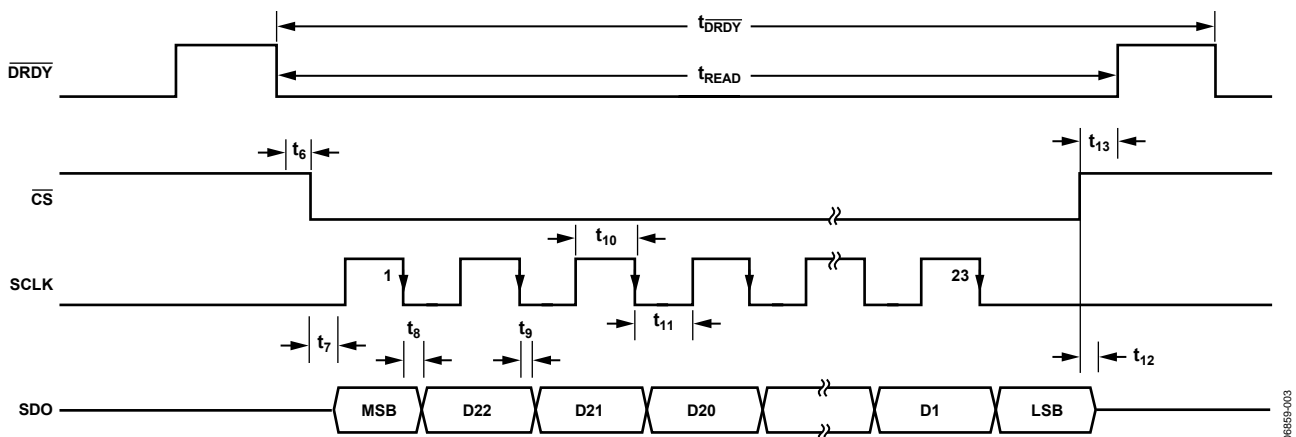

Figure 3. Serial Timing Diagram, Reading Data Using \overline{CS}

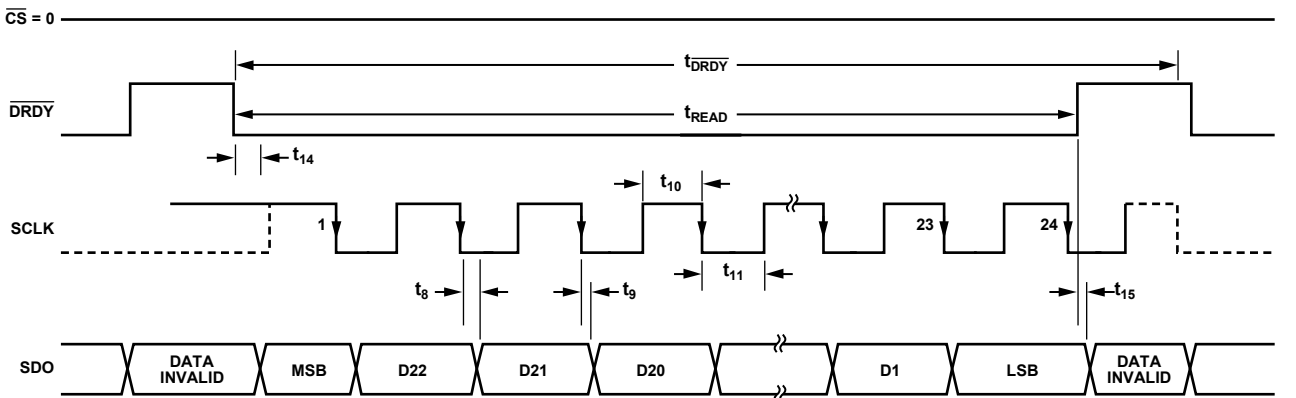

Figure 4. Serial Timing Diagram, Reading Data Setting \overline{CS} Logic Low

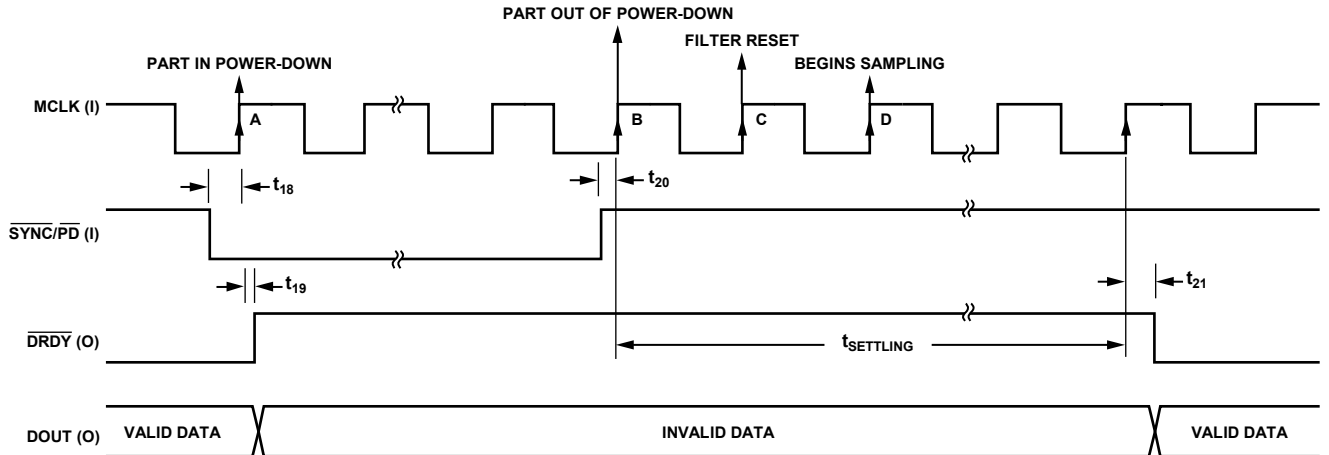

Figure 5. Reset, Synchronization, and Power-Down Timing Diagram

04859-005

ABSOLUTE MAXIMUM RATINGS

$T_A = 25^\circ\text{C}$, unless otherwise noted.

Table 4.

Parameter	Rating
AV_{DD} to AGND	-0.3 V to +3 V
DV_{DD} to DGND	-0.3 V to +3 V
AV_{DD} to DV_{DD}	-0.3 V to +0.3 V
V_{REF+} to REFGND	-0.3 V to +7 V
REFGND to AGND	-0.3 V to +0.3 V
V_{DRIVE} to DGND	-0.3 V to +6 V
V_{IN+}, V_{IN-} to AGND	-0.3 V to $V_{REF} + 0.3$ V
Digital Inputs to DGND	-0.3 V to $V_{DRIVE} + 0.3$ V
Digital Outputs to DGND	-0.3 V to $V_{DRIVE} + 0.3$ V
AGND to DGND	-0.3 V to +0.3 V
Input Current to Any Pin Except Supplies ¹	± 10 mA
Operating Temperature Range	-40°C to $+105^\circ\text{C}$
Storage Temperature Range	-65°C to $+150^\circ\text{C}$
Junction Temperature	150°C
TSSOP Package	
θ_{JA} Thermal Impedance	$150.4^\circ\text{C}/\text{W}$
θ_{JC} Thermal Impedance	$27.6^\circ\text{C}/\text{W}$
Lead Temperature, Soldering	
Vapor Phase (60 sec)	215°C
Infrared (15 sec)	220°C
ESD	1 kV

¹ Transient currents of up to 100 mA do not cause SCR latch-up.

Stresses above those listed under Absolute Maximum Ratings may cause permanent damage to the device. This is a stress rating only; functional operation of the device at these or any other conditions above those indicated in the operational section of this specification is not implied. Exposure to absolute maximum rating conditions for extended periods may affect device reliability.

ESD CAUTION



ESD (electrostatic discharge) sensitive device. Charged devices and circuit boards can discharge without detection. Although this product features patented or proprietary protection circuitry, damage may occur on devices subjected to high energy ESD. Therefore, proper ESD precautions should be taken to avoid performance degradation or loss of functionality.

PIN CONFIGURATION AND FUNCTION DESCRIPTIONS

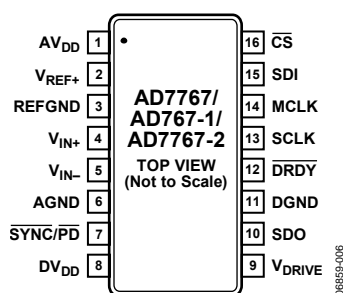

Figure 6. 16-Lead TSSOP Pin Configuration

Table 5. Pin Function Descriptions

Pin No.	Mnemonic	Description
1	AV _{DD}	+2.5 V Analog Power Supply.
2	V _{REF+}	Reference Input for the AD7767. An external reference must be applied to this input pin. The V _{REF+} input can range from 2.4 V to 5 V. The reference voltage input is independent of the voltage magnitude applied to the AV _{DD} pin.
3	REFGND	Reference Ground. Ground connection for the reference voltage. The input reference voltage (V _{REF+}) should be decoupled to this pin.
4	V _{IN+}	Positive Input of the Differential Analog Input.
5	V _{IN-}	Negative Input of the Differential Analog Input.
6	AGND	Power Supply Ground for Analog Circuitry.
7	SYNC/PD	Synchronization and Power-Down Input Pin. This pin has dual functionality. It can be used to synchronize multiple AD7767 devices and/or put the AD7767 device into power-down mode. See the Power-Down, Reset, and Synchronization section for further details.
8	DV _{DD}	Digital Power Supply Input. This pin can be connected directly to V _{DRIVE} .
9	V _{DRIVE}	Logic Power Supply Input, +1.8 V to +3.6 V. The voltage supplied at this pin determines the operating voltage of the digital logic interface.
10	SDO	Serial Data Output (SDO). The conversion result from the AD7767 is output on the SDO pin as a 24-bit, twos complement, MSB first, serial data stream.
11	DGND	Digital Logic Power Supply Ground.
12	DRDY	Data Ready Output. A falling edge on the DRDY signal indicates that a new conversion data result is available in the output register of the AD7767. See the AD7767 Interface section for further details.
13	SCLK	Serial Clock Input. The SCLK input provides the serial clock for all serial data transfers with the AD7767 device. See the AD7767 Interface section for further details.
14	MCLK	Master Clock Input. The AD7767 sampling frequency is equal to the MCLK frequency.
15	SDI	Serial Data Input. This is the daisy chain input of the AD7767. See the Daisy Chaining section for further details.
16	CS	Chip Select Input. The CS input selects the AD7767 device and acts as an enable on the SDO pin. In cases where CS is used, the MSB of the conversion result is clocked onto the SDO line on the CS falling edge. The CS input allows multiple AD7767 devices to share the same SDO line. This allows the user to select the appropriate device by supplying it with a logic low CS signal, which enables the SDO pin of the device concerned. See the AD7767 Interface section for further details.

TYPICAL PERFORMANCE CHARACTERISTICS

$V_{DD} = DV_{DD} = 2.5 \text{ V} \pm 5\%$, $V_{DRIVE} = 1.8 \text{ V to } 3.6 \text{ V}$, $V_{REF} = 5 \text{ V}$, $MCLK = 1 \text{ MHz}$, common-mode input = $V_{REF}/2$. $T_A = 25^\circ\text{C}$, unless otherwise noted. All FFTs were generated using 8192 samples using a 4-term Blackman-Harris window.

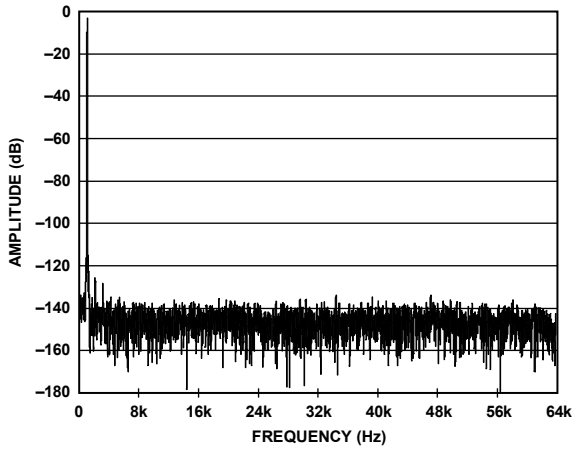

Figure 7. AD7767 FFT, 1 kHz, -0.5 dB Input Tone

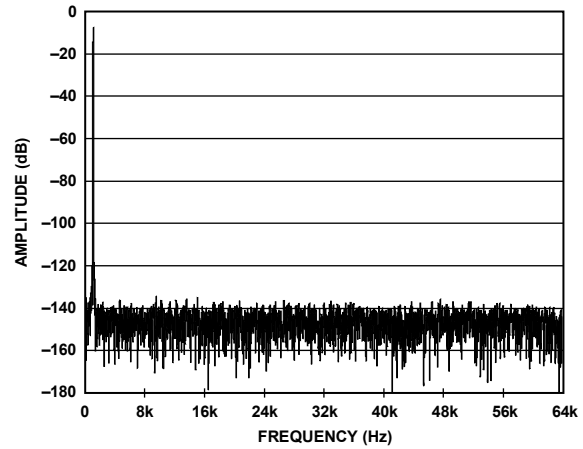

Figure 10. AD7767 FFT, 1 kHz, -6 dB Input Tone

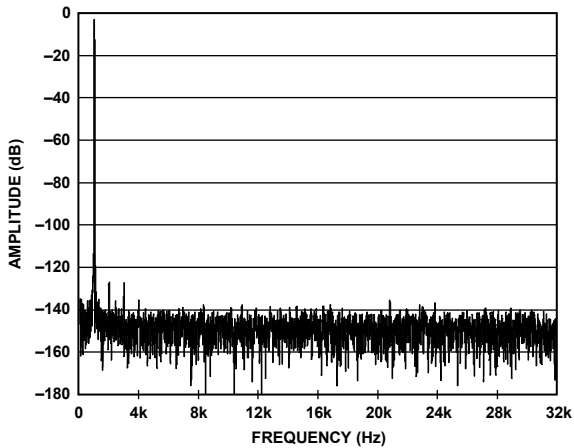

Figure 8. AD7767-1 FFT, 1 kHz, -0.5 dB Input Tone

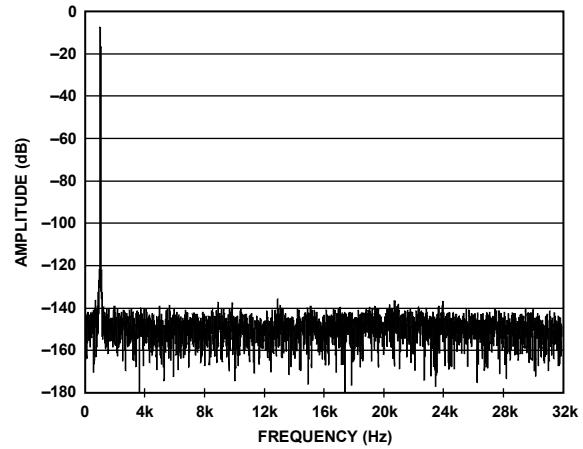

Figure 11. AD7767-1 FFT, 1 kHz, -6 dB Input Tone

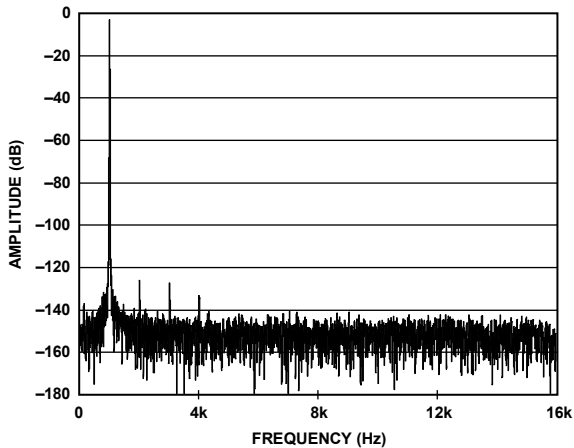

Figure 9. AD7767-2 FFT, 1 kHz, -0.5 dB Input Tone

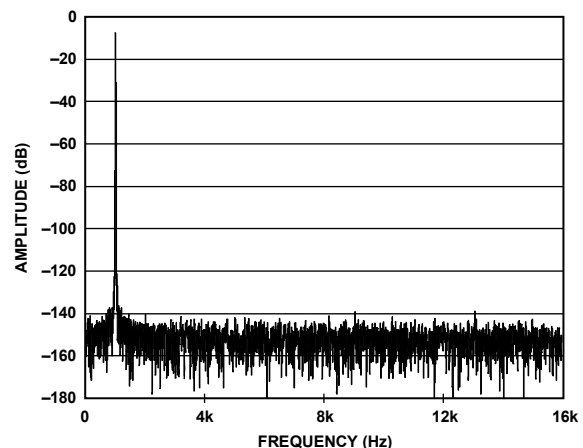

Figure 12. AD7767-2 FFT, 1 kHz, -6 dB Input Tone

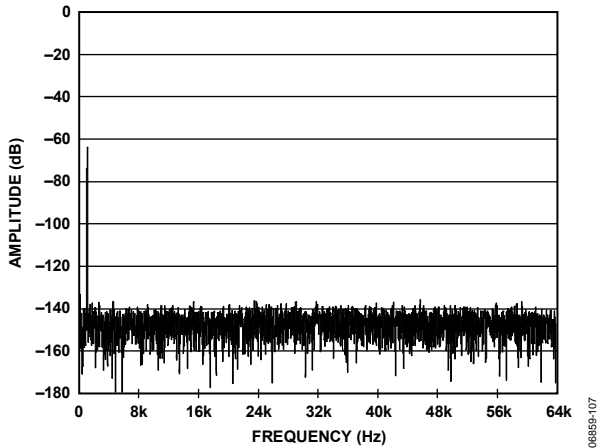

Figure 13. AD7767 FFT, 1 kHz, -60 dB Input Tone

06859-107

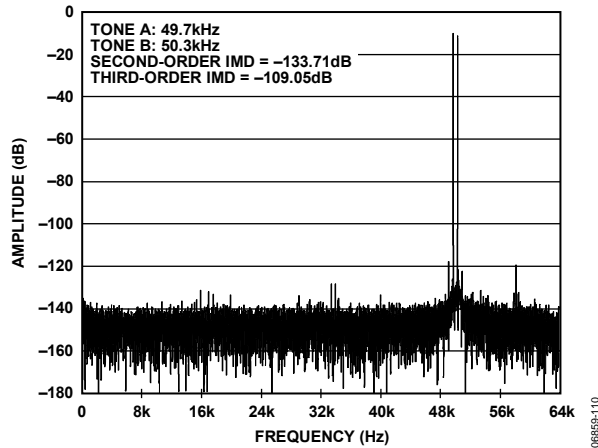

Figure 16. AD7767 IMD FFT, 50 kHz Center Frequency

06859-110

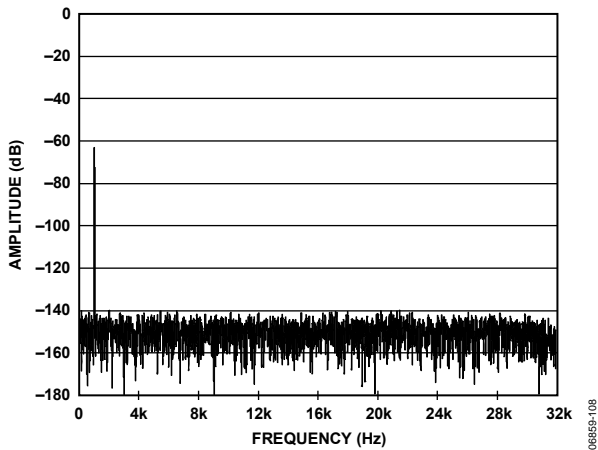

Figure 14. AD7767-1 FFT, 1 kHz, -60 dB Input Tone

06859-108

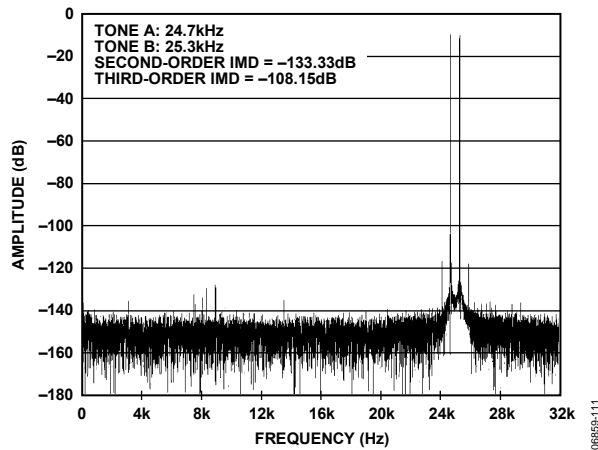

Figure 17. AD7767-1 IMD FFT, 25 kHz Center Frequency

06859-111

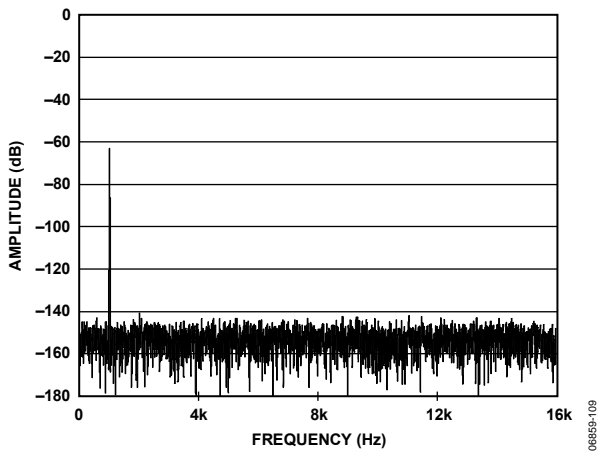

Figure 15. AD7767-2 FFT, 1 kHz, -60 dB Input Tone

06859-109

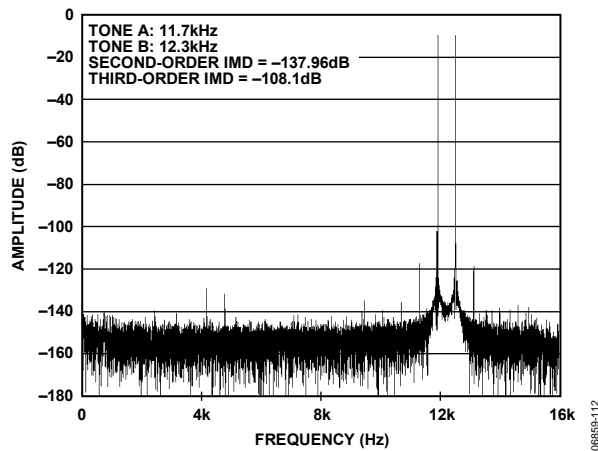

Figure 18. AD7767-2 IMD FFT, 12 kHz Center Frequency

06859-112

AD7767

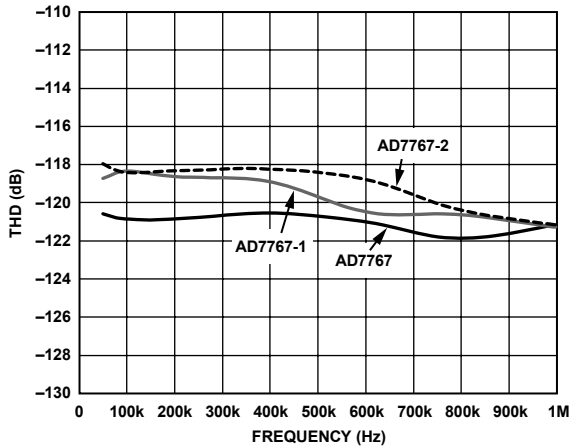

Figure 19. AD7767/AD7767-1/AD7767-2 THD vs. MCLK Frequency

06859-113

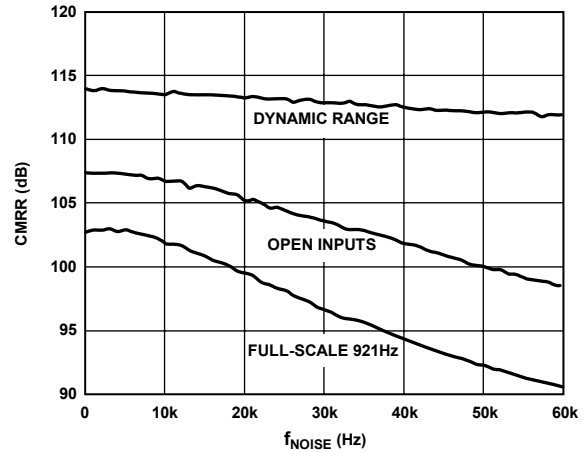

Figure 22. AD7767 CMRR vs. Common-Mode Ripple Frequency

06859-116

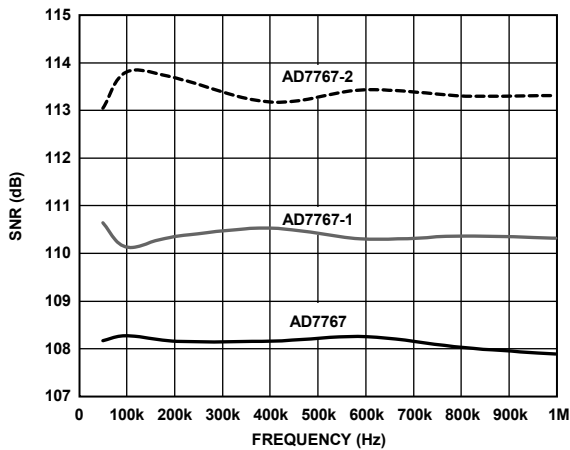

Figure 20. AD7767/AD7767-1/AD7767-2 SNR and THD vs. MCLK Frequency

06859-114

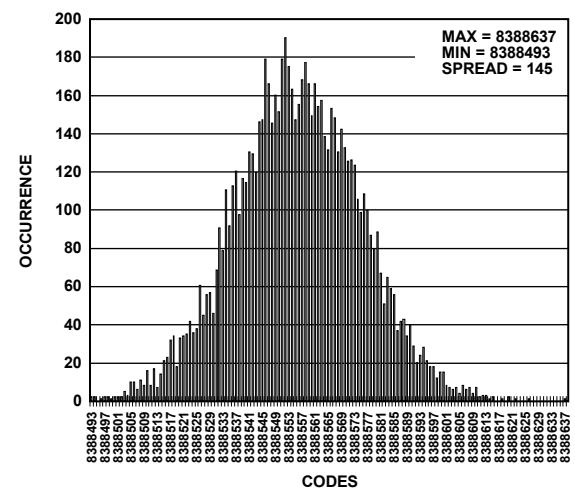

Figure 23. AD7767 24-Bit Histogram

06859-118

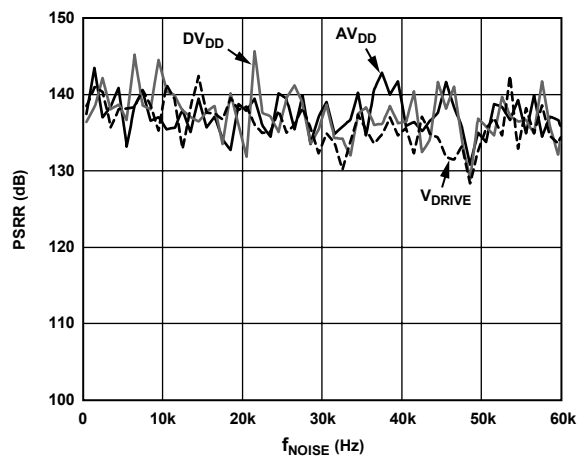

Figure 21. AD7767 Power Supply Sensitivity vs. Supply Ripple Frequency with Decoupling Capacitors

06859-117

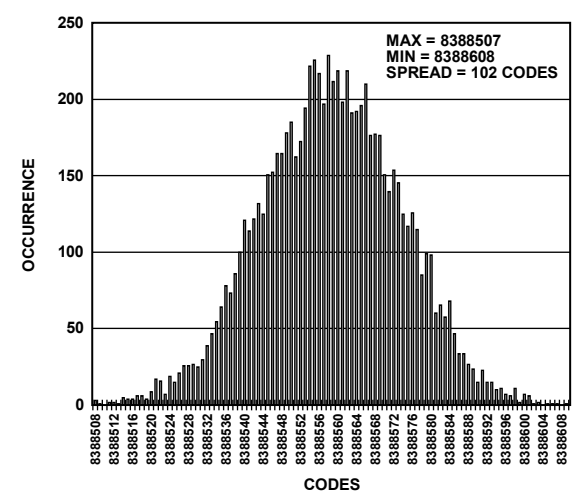

Figure 24. AD7767-1 24-Bit Histogram

06859-119

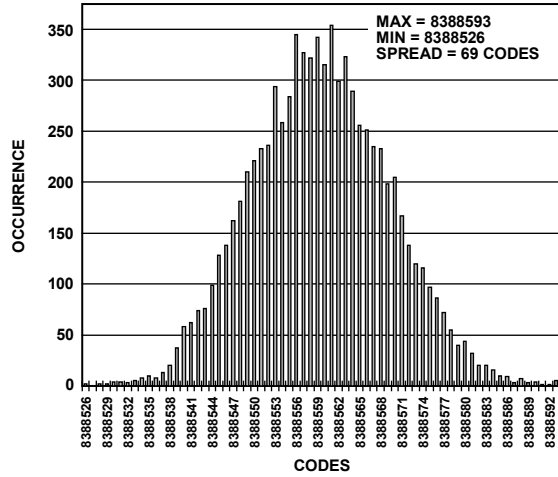

Figure 25. AD7767-2 24-Bit Histogram

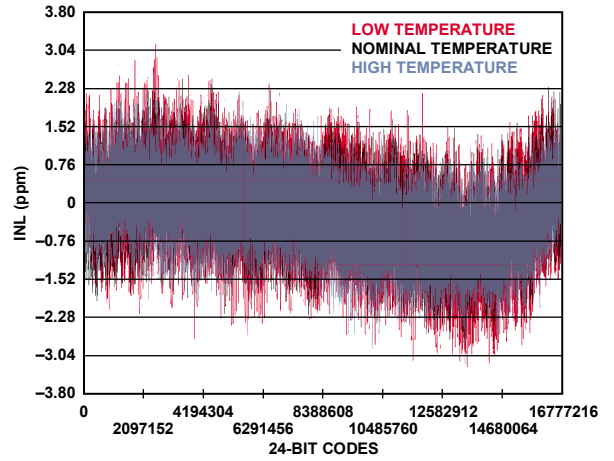

Figure 27. AD7767/AD7767-1/AD7767-2, 24-Bit INL

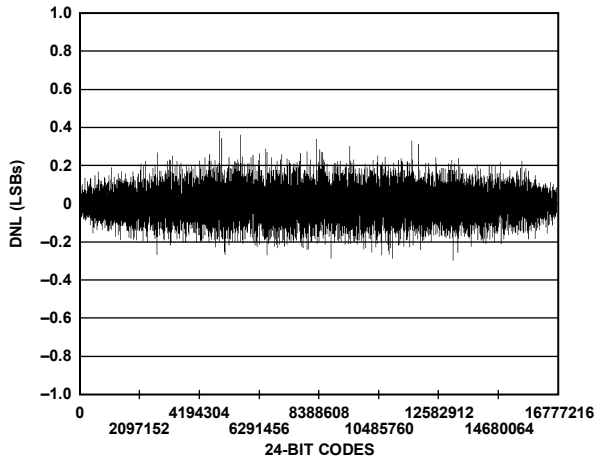

Figure 26. AD7767/AD7767-1/AD7767-2, 24-Bit DNL

06869-120

06869-122

06869-121

TERMINOLOGY

Signal-to-Noise Ratio (SNR)

SNR is the ratio of the rms value of the actual input signal to the rms sum of all other spectral components below the Nyquist frequency, excluding harmonics and dc. The value for SNR is expressed in decibels.

Total Harmonic Distortion (THD)

THD is the ratio of the rms sum of harmonics to the fundamental. For the AD7767, it is defined as

$$THD \text{ (dB)} = 20 \log \frac{\sqrt{V_2^2 + V_3^2 + V_4^2 + V_5^2 + V_6^2}}{V_1}$$

where:

V_1 is the rms amplitude of the fundamental.

$V_2, V_3, V_4, V_5,$ and V_6 are the rms amplitudes of the second to the sixth harmonics.

Nonharmonic Spurious-Free Dynamic Range (SFDR)

SFDR is the ratio of the rms signal amplitude to the rms value of the peak spurious spectral component, excluding harmonics.

Dynamic Range

Dynamic range is the ratio of the rms value of the full scale to the rms noise measured with the inputs shorted together. The value for the dynamic range is expressed in decibels.

Intermodulation Distortion

With inputs consisting of sine waves at two frequencies, f_a and f_b , any active device with nonlinearities creates distortion products at sum and difference frequencies of $m f_a \pm n f_b$, where $m, n = 0, 1, 2, 3,$ and so on. Intermodulation distortion terms are those for which neither m nor n are equal to 0. For example, the second-order terms include $(f_a + f_b)$ and $(f_a - f_b)$, and the third-order terms include $(2f_a + f_b), (2f_a - f_b), (f_a + 2f_b),$ and $(f_a - 2f_b)$.

The AD7767 is tested using the CCIF standard, where two input frequencies near the top end of the input bandwidth are used.

In this case, the second-order terms are usually distanced in frequency from the original sine waves, and the third-order terms are usually at a frequency close to the input frequencies. As a result, the second- and third-order terms are specified separately. The calculation of the intermodulation distortion is as per the THD specification, where it is the ratio of the rms

sum of the individual distortion products to the rms amplitude of the sum of the fundamentals expressed in decibels.

Integral Nonlinearity (INL)

INL is the maximum deviation from a straight line passing through the endpoints of the ADC transfer function.

Differential Nonlinearity (DNL)

DNL is the difference between the measured and the ideal 1 LSB change between any two adjacent codes in the ADC.

Zero Error

Zero error is the difference between the ideal midscale input voltage (when both inputs are shorted together) and the actual voltage producing the midscale output code.

Zero Error Drift

Zero error drift is the change in the actual zero error value due to a temperature change of 1°C. It is expressed as a percentage of full scale at room temperature.

Gain Error

The first transition (from 100...000 to 100...001) should occur for an analog voltage ½ LSB above the nominal negative full scale. The last transition (from 011...110 to 011...111) should occur for an analog voltage ½ LSB below the nominal full scale. The gain error is the deviation of the difference between the actual level of the last transition and the actual level of the first transition, from the difference between the ideal levels.

Gain Error Drift

Gain error drift is the change in the actual gain error value due to a temperature change of 1°C. It is expressed as a percentage of full scale at room temperature.

Common-Mode Rejection Ratio (CMRR)

CMRR is defined as the ratio of the power in the ADC output at full-scale frequency f to the power of a 100 mV sine wave applied to the common-mode voltage of the V_{IN+} and V_{IN-} inputs at frequency f_s .

$$CMRR \text{ (dB)} = 10 \log(P_f/P_{f_s})$$

where P_f is the power at the frequency f in the ADC output and P_{f_s} is the power at the frequency f_s in the ADC output.

THEORY OF OPERATION

The AD7767/AD7767-1/AD7767-2 operate using a fully differential analog input applied to a successive approximation (SAR) core. The output of the oversampled SAR is filtered using a linear phase digital FIR filter. The fully filtered data is output in a serial format, with the MSB being clocked out first.

AD7767/AD7767-1/AD7767-2 TRANSFER FUNCTION

The conversion results of the AD7767/AD7767-1/AD7767-2 are output in a twos complement, 24-bit serial format. The fully differential inputs V_{IN+} and V_{IN-} are scaled by the AD7767/AD7767-1/AD7767-2 relative to the reference voltage input (V_{REF+}), as shown in Figure 28.

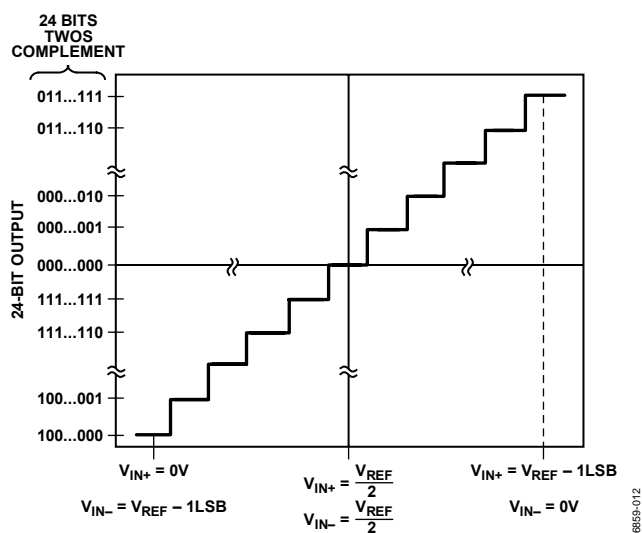

Figure 28. AD7767/AD7767-1/AD7767-2 Transfer Function

CONVERTER OPERATION

Internally, the input waveform applied to the SAR core is converted and an equivalent digital word is output to the digital filter at a rate equal to MCLK. By employing oversampling, the quantization noise of the converter is spread across a wide bandwidth from 0 to f_{MCLK} . This means that the noise energy contained in the signal band of interest is reduced (see Figure 29).

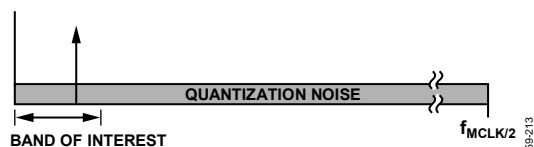

Figure 29. Quantization Noise

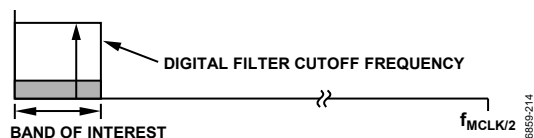

Figure 30. Digital Filter Cutoff Frequency

The digital filtering that follows the converter output acts to remove the out-of-band quantization noise (see Figure 30). This also has the effect of reducing the data rate from f_{MCLK} at the input of the filter to $f_{MCLK}/8$, $f_{MCLK}/16$, or $f_{MCLK}/32$ at the digital output, depending on which model of the device is being used.

The digital filter consists of three separate filter blocks. Figure 31 shows the three constituent blocks of the filter. The order of decimation of the first filter block is set as 2, 4, or 8. The remaining sections both operate in decimate by 2.

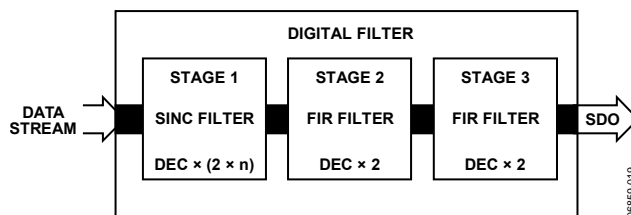

Figure 31. FIR Filter Stages
($n = 1$ for AD7767, $n = 2$ for AD7767-1, $n = 4$ for AD7767-2)

Table 6 shows the three available models of the AD7767, listing the change in output data rate relative to the order of decimation rate implemented. This brings into focus the trade-off that exists between extra filtering and reduction in bandwidth, whereby using a filter option with a larger decimation rate increases the noise performance while decreasing the usable input bandwidth.

Table 6. AD7767 Models

Model	Decimation Rate	Output Data Rate (ODR)
AD7767	8	128 kHz
AD7767-1	16	64 kHz
AD7767-2	32	32 kHz

Note that the output data rates shown in Table 6 are realized when using the maximum MCLK input frequency of 1.024 MHz. The output data rate scales linearly with the MCLK frequency, as does the digital power dissipated in the device.

The settling time of the filter implemented on the AD7767, AD7767-1, and AD7767-2 is related to the length of the filter employed. The response of the filter in the time domain sets the filter settling time. Table 7 shows the filter settling times of the AD7767/AD7767-1/AD7767-2.

The frequency responses of the digital filters on the AD7767, AD7767-1, and AD7767-2 are shown in Figure 32, Figure 33, and Figure 34, respectively. At the Nyquist frequency (output data rate/2), the digital filter provides 6 dB of attenuation. In each case, the filter provides stop-band attenuation of 100 dB and pass-band ripple of ± 0.005 dB.

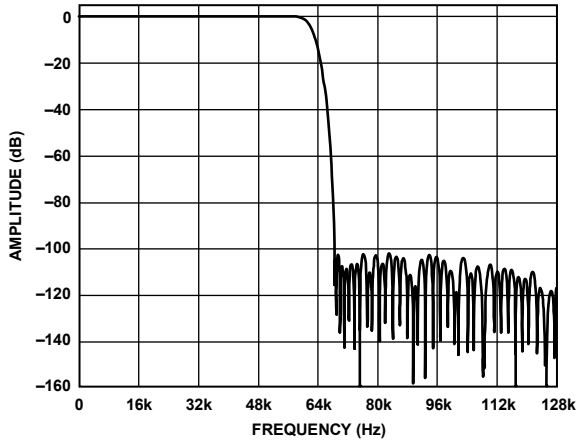

Figure 32. AD7767 Digital Filter Frequency Response

06859-216

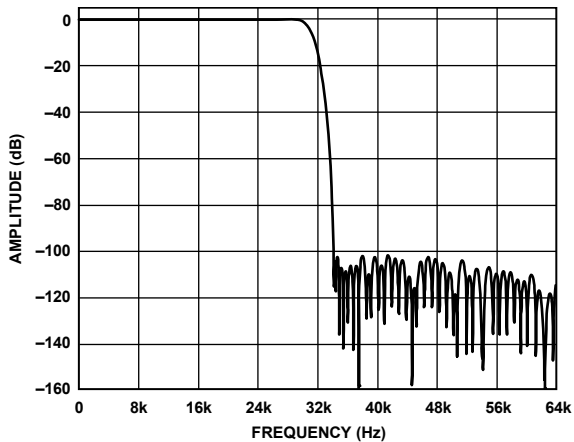

Figure 33. AD7767-1 Digital Filter Frequency Response

06859-217

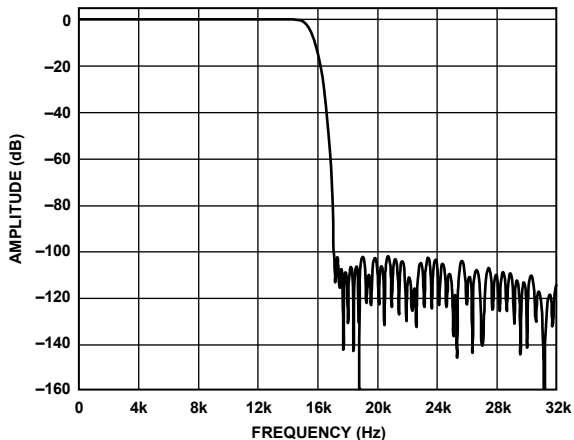

Figure 34. AD7767-2 Digital Filter Frequency Response

06859-218

ANALOG INPUT STRUCTURE

The AD7767/AD7767-1/AD7767-2 are configured as a differential input structure. A true differential signal is sampled between the analog inputs V_{IN+} and V_{IN-} , Pin 4 and Pin 5, respectively. Using differential inputs provides rejection of signals that are common to both the V_{IN+} and V_{IN-} pins.

Figure 35 shows the equivalent analog input circuit of the AD7767/AD7767-1/AD7767-2. The two diodes on each of the differential inputs provide ESD protection for the analog inputs.

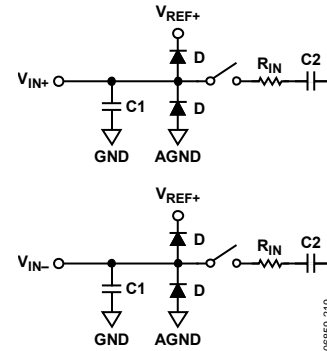

Figure 35. Equivalent Analog Input Structure

Take care to ensure that the analog input signal does not exceed the reference supply voltage V_{REF+} by more than 0.3 V as specified in the Absolute Maximum Ratings section. The diodes become forward biased if the input voltage exceeds this limit and start to conduct current. The diodes can handle 130 mA maximum.

The impedance of the analog inputs can be modeled as a parallel combination of $C1$ and the network formed by the series connection of R_{IN} , $C1$, and $C2$. The value of $C1$ is dominated by the pin capacitance. R_{IN} is typically 1.4 k Ω , the lumped component of serial resistors and the R_{ON} of the switches. $C2$ is typically 22 pF, and its value is dominated by the sampling capacitor.

SUPPLY AND REFERENCE VOLTAGES

The AD7767/AD7767-1/AD7767-2 operate from a 2.5 V supply applied to the DV_{DD} , AV_{DD} pins. The interface is specified to operate between 1.7 V and 3.6 V. The AD7767/AD7767-1/AD7767-2 operate from a 5 V reference applied to the V_{REF+} pin. The recommended reference devices are the [ADR445](#) or the [ADR425](#). The 5 V reference operates both as a reference supply and as a power supply to the AD7767/AD7767-1/AD7767-2 device. This feature means that the full-scale differential input range of the AD7767/AD7767-1/AD7767-2 is 10 V. See the Driving the AD7767 section for details on the maximum input voltage.

AD7767 INTERFACE

The AD7767 provides the user with a flexible serial interface, enabling the user to implement the most desirable interfacing scheme for their application. The AD7767 interface comprises seven different signals. Five of these signals are inputs: MCLK, CS, SYNC/PD, SCLK, and SDI. There are two output signals: DRDY and SDO.

INITIAL POWER-UP

On initial power-up, apply a continuous MCLK signal. It is recommended that the user reset the AD7767 to clear the filters and ensure correct operation. The reset is completed as described in Figure 5, with all events occurring relative to the rising edge of MCLK. A negative pulse on the SYNC/PD input initiates the reset, and the DRDY output switches to logic high and remains high until valid data is available. Following the power-up of the AD7767 by transitioning the SYNC/PD pin to logic high, a settling time is required before valid data is output by the device. This settling time, t_{SETTLING} , is a function of the MCLK frequency and the decimation rate. Table 7 lists the settling time of each of the AD7767 models and should be referenced to Figure 5.

Table 7. Filter Settling Time After SYNC/PD

Model	Decimation Rate	t_{SETTLING}^1
AD7767	8	$594 \times (t_{\text{MCLK}} + t_{21})$
AD7767-1	16	$1186 \times (t_{\text{MCLK}} + t_{21})$
AD7767-2	32	$2370 \times (t_{\text{MCLK}} + t_{21})$

¹ t_{SETTLING} is measured from the first MCLK rising edge after the rising edge of SYNC/PD to the falling edge of DRDY.

READING DATA

The AD7767 outputs its data conversion results in an MSB first, twos complement, 24-bit format on the serial data output pin (SDO). MCLK is the master clock, which controls all the AD7767 conversions. The SCLK is the serial clock input for the device. All data transfers take place with respect to the SCLK signal.

The DRDY line is used as a status signal to indicate when the data is available to be read from the AD7767. The falling edge of DRDY indicates that a new data-word is available in the output register of the device. DRDY stays low during the period that output data is permitted to be read from the SDO pin. The DRDY signal returns to logic high to indicate when not to read from the device. Ensure that a data read is not attempted during this period as the output register is being updated.

The AD7767 offers the user the option of using a chip select input signal ($\overline{\text{CS}}$) in its data read cycle. The $\overline{\text{CS}}$ signal is a gate for the SDO pin and allows many AD7767 devices to share the same serial bus, acting as an instruction signal to each of these

devices indicating permission to use the bus. When $\overline{\text{CS}}$ is logic high, the SDO line of the AD7767 is tristated.

There are two distinct patterns that can be initiated to read data from the AD7767 device; these are for the cases when the CS falling edge occurs after the DRDY falling edge and for the case when the CS falling edge occurs before the DRDY falling edge (when $\overline{\text{CS}}$ is set to logic low).

When the $\overline{\text{CS}}$ falling edge occurs after DRDY falling edge, the MSB of the conversion result is available on the SDO line on this CS falling edge. The remaining bits of the conversion result (MSB-1, MSB-2, and so on) are clocked onto the SDO line by the falling edges of SCLK that follow the CS falling edge. Figure 3 details this interfacing scheme.

When $\overline{\text{CS}}$ is tied low, the AD7767 serial interface can operate in 3-wire mode as shown in Figure 4. In this case, the MSB of the conversion result is available on the SDO line on the falling edge of DRDY. The remaining bits of the data conversion result (MSB-1, MSB-2, and so on) are clocked onto the SDO line by the subsequent SCLK falling edges.

POWER-DOWN, RESET, AND SYNCHRONIZATION

The AD7767 SYNC/PD pin allows the user to synchronize multiple AD7767 devices. This pin also allows the user to reset and power down the AD7767 device. These features are implemented relative to the rising edges of MCLK and are shown in Figure 5.

To power down, reset, or synchronize a device, the AD7767 SYNC/PD pin should be taken low. On the first rising edge of MCLK, the AD7767 is powered down. The DRDY pin transitions to logic high, indicating that the data in the output register is no longer valid. The status of the SYNC/PD pin is checked on each subsequent rising edge of MCLK. On the first rising edge of MCLK after the SYNC/PD pin is taken high, the AD7767 is taken out of power-down. On the next rising edge, the filter of the AD7767 is reset. On the following rising edge, the first new sample is taken.

A settling time, t_{SETTLING} , from the filter reset, must pass before valid data is output by the device (as listed in Table 7). The DRDY output goes logic low after t_{SETTLING} to indicate when valid data is available on SDO for readback.

DAISY CHAINING

Daisy chaining devices allows numerous devices to use the same digital interface lines by cascading the outputs of multiple ADCs on a single data line. This feature is especially useful for reducing component count and wiring connections, for example, in isolated multiconverter applications or for systems with a limited interfacing capacity. Data readback is analogous to clocking a shift register where data is clocked on the falling edge of SCLK.

The block diagram in Figure 36 shows the way in which devices must be connected in order to achieve daisy chain functionality. This scheme operates by passing the output data of the SDO pin of an AD7767 device to the SDI input of the next AD7767 device in the chain. The data then continues through the chain until it is clocked onto the SDO pin of the first device on the chain.

READING DATA IN DAISY CHAIN MODE

An example of a daisy chain of four AD7767 devices is shown in Figure 36 and Figure 37. In the case illustrated in Figure 36, the output of AD7767 (A) is the output of the full daisy chain. The last device in the chain (AD7767 (D)) has its serial data in (SDI) pin connected to ground. All the devices in the chain must use common MCLK, SCLK, $\overline{\text{CS}}$, and SYNC/PD signals.

To enable the daisy chain conversion process, apply a common SYNC/PD pulse to all devices, synchronizing all the devices in the chain (see the Power-Down, Reset, and Synchronization section).

After applying a $\overline{\text{SYNC/PD}}$ pulse to all the devices, there is a delay (as listed in Table 7) before valid conversion data appears at the output of the chain of devices. As shown in Figure 37, the first conversion result is output from the device labeled AD7767 (A). This 24-bit conversion result is followed by the conversion results from the devices B, C, and D, respectively, with all conversion results output in an MSB first sequence. The stream of conversion results is clocked through each device in the chain and is eventually clocked onto the SDO pin of the AD7767 (A) device. The conversion results of the all the devices in the chain must be clocked onto the SDO pin of the final

device in the chain while its $\overline{\text{DRDY}}$ signal is active low. This is illustrated in the example shown where the conversion results from devices A, B, C, and D are clocked onto SDO (A) in the time between the falling edge of $\overline{\text{DRDY}}$ (A) and the rising edge of $\overline{\text{DRDY}}$ (A).

CHOOSING THE SCLK FREQUENCY

As shown in Figure 36, the number of SCLK falling edges that occur during the period when $\overline{\text{DRDY}}$ (A) is active low must match the number of devices in the chain multiplied by 24 (the number of bits that must be clocked through onto SDO (A) for each device).

The period of SCLK (t_{SCLK}) required for a known daisy chain length using a known common MCLK frequency must therefore be established in advance. Note that the maximum SCLK frequency is governed by t_8 and is specified in the Timing Specifications table for different V_{DRIVE} voltages.

In the case where $\overline{\text{CS}}$ is tied logic low,

$$t_{\text{SCLK}} \leq \left[\frac{t_{\text{READ}}}{24 \times K} \right] \quad (1)$$

where:

K is the number of AD7767 devices in the chain.

t_{SCLK} is the period of the SCLK.

t_{READ} equals $t_{\overline{\text{DRDY}}} - t_5$.

In the case where $\overline{\text{CS}}$ is used in the daisy chain interface,

$$t_{\text{SCLK}} \leq \left[\frac{(t_{\text{READ}}) - (t_6 + t_7 + t_{13})}{24 \times K} \right] \quad (2)$$

where:

K is the number of AD7767 devices in the chain.

Note that the maximum value of SCLK is governed by t_8 and is specified in the Timing Specifications table for different V_{DRIVE} voltages.

DAISY CHAIN MODE CONFIGURATION AND TIMING DIAGRAMS

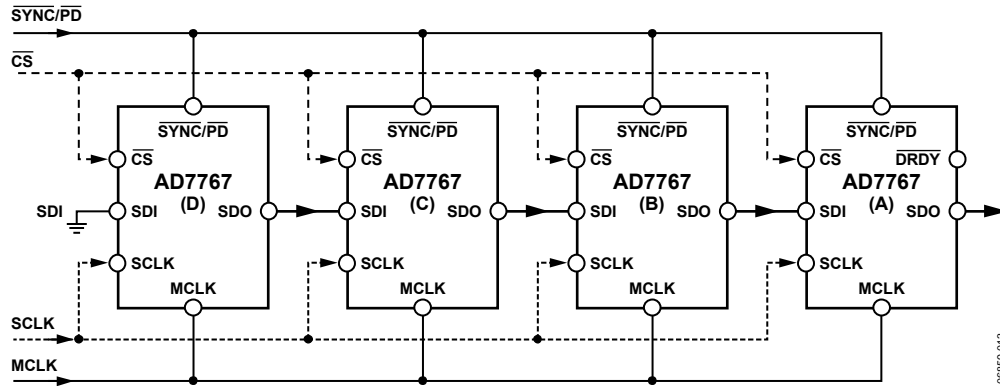

Figure 36. AD7767 Daisy Chain Configuration with Four AD7767 Devices

06859-013

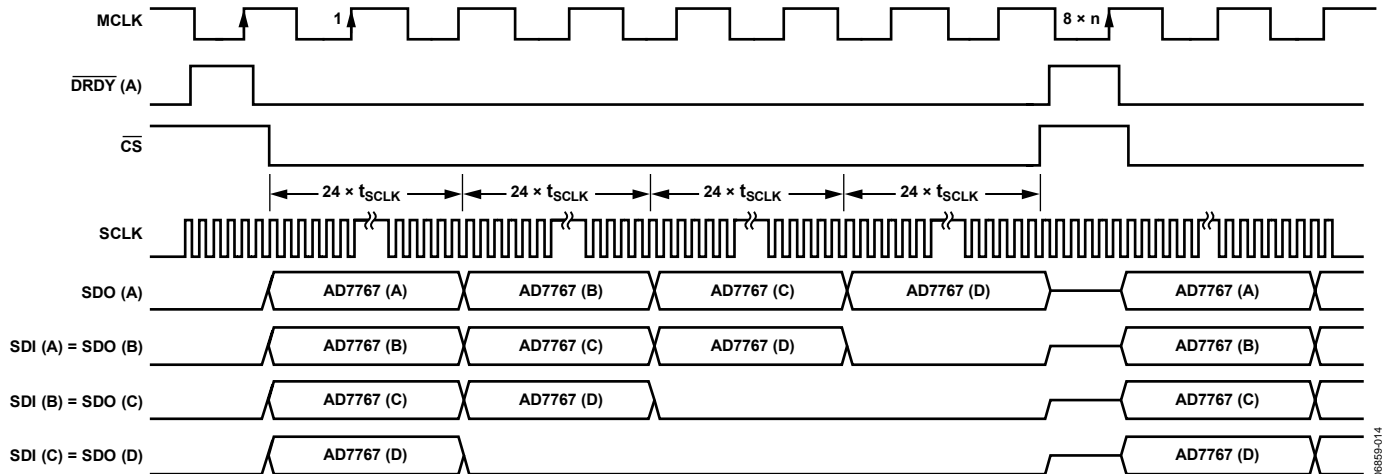

Figure 37. AD7767 Daisy Chain Timing Diagram ($n = 1$ for AD7767, $n = 2$ for AD7767-1, $n = 4$ for AD7767-2) Driving the AD7767

06859-014

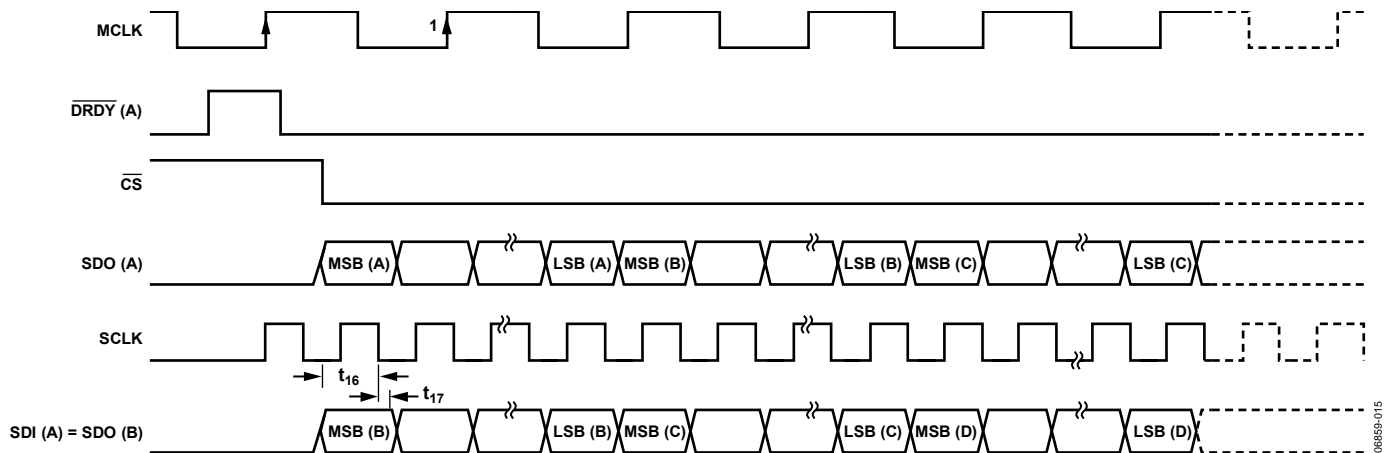

Figure 38. AD7767 Daisy Chain SDI Setup and Hold Timing

06859-015

DRIVING THE AD7767

The AD7767 must be driven with fully differential inputs. The common-mode voltage of the differential inputs to the AD7767 device and thus the limits on the differential inputs are set by the reference voltage V_{REF} applied to the device. The common-mode voltage of the AD7767 is $V_{REF}/2$. Where the AD7767 V_{REF+} pin is supplied with a 5 V supply (the [ADR445](#) or [ADR425](#)), the common mode is at 2.5 V. This means that the maximum inputs that can be applied on the AD7767 differential inputs are a 5 V p-p input around 2.5 V.

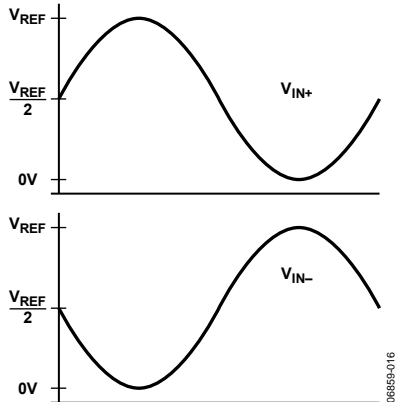

Figure 39. Maximum Differential Inputs to the AD7767

An analog voltage of 2.5 V supplies the AD7767 AV_{DD} pin. However, the AD7767 allows the user to apply a reference voltage of up to 5 V. This provides the user with an increased full-scale range, offering the user the option of using the AD7767 with a larger LSB voltage size. Figure 39 shows the maximum and minimum inputs to the AD7767.

DIFFERENTIAL SIGNAL SOURCE

An example of some recommended driving circuitry that can be employed in conjunction with the AD7767/AD7767-1/AD7767-2 is shown in Figure 40. Figure 40 shows how the [ADA4841-1](#) device can be used to drive an input to the AD7767/AD7767-1/AD7767-2 from a differential source. Each of the differential paths is driven by an ADA4841-1 device.

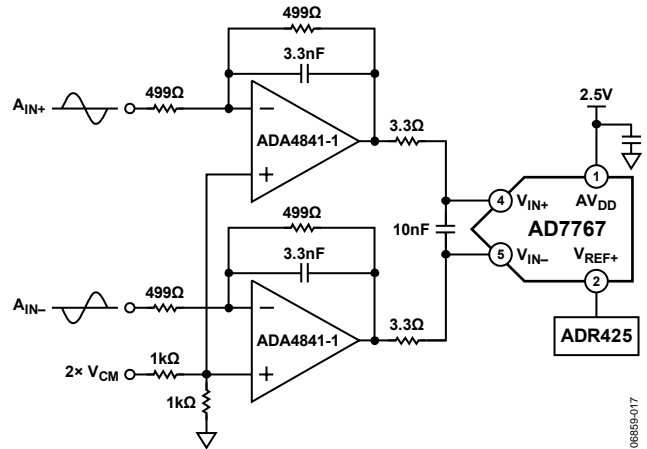

Figure 40. Driving the AD7767 from a Fully Differential Source

SINGLE-ENDED SIGNAL SOURCE

In the case where the AD7767 is being supplied from a single-ended source, the application circuit in Figure 41 can be used to drive the AD7767 device. Figure 41 shows how the [ADA4941-1](#) single-to-differential amplifier can be used to create a fully differential input to the AD7767. The single-ended signal input is applied to the positive input of the ADA4941-1 device. Arrange the values of the resistor elements to create a 2.5 V common-mode input to the AD7767/AD7767-1/AD7767-2 device. R_3 and C_2 default to 3.3 Ω and 10 nF, respectively.

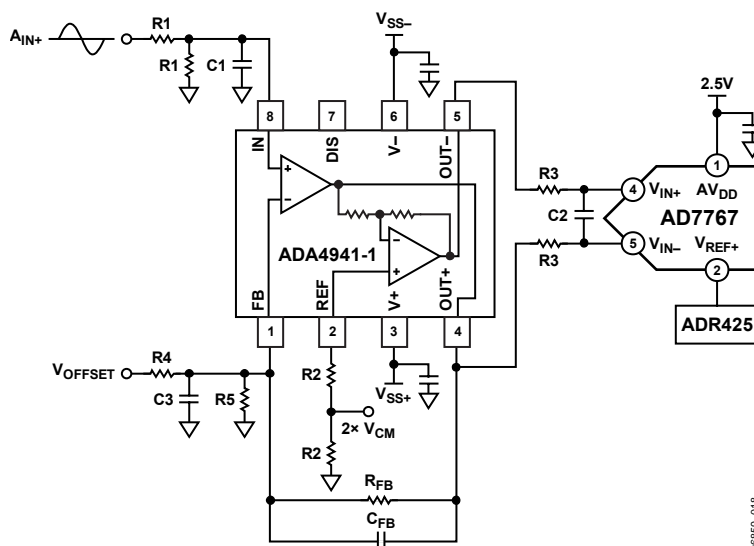

Figure 41. Driving the AD7767 from a Single-Ended Source

ANTI_ALIASING

The AD7767/AD7767-1/AD7767-2 sample the analog input at a maximum rate of 1.024 MHz. The on-board digital filter provides up to 100 dB attenuation of any possible aliasing frequencies in the range from the beginning of the filter stop band ($0.547 \times \text{ODR}$) to where the image of the digital filter pass band occurs at $\text{MCLK} - \text{filter stop band}$ ($\text{MCLK} - 0.547 \times \text{ODR}$), which is the first alias point. This is illustrated in Figure 42.

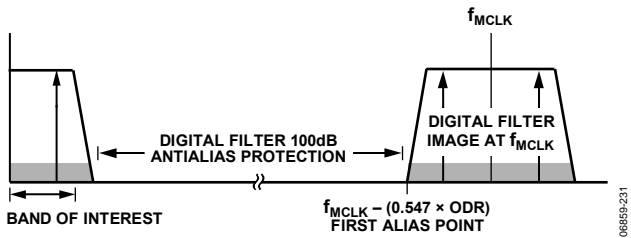

Figure 42. AD7767/AD7767-1/AD7767 Spectrum

Table 8 shows the attenuation achieved by various orders of front-end antialias filters prior to the AD7767/AD7767-1/AD7767-2 at the image of the digital filter stop band, which is $1.024 \text{ MHz} - 0.547 \times \text{ODR}$.

Table 8. Antialias Filter Order Attenuation at First Alias Point

Model	Filter Order	Attenuation at $1.024 \text{ MHz} - 0.547 \times \text{ODR}$
AD7767	1 st	27 dB
	2 nd	50 dB
	3 rd	70 dB
AD7767-1	1 st	33 dB
	2 nd	62 dB
	3 rd	89 dB
AD7767-2	1 st	38 dB
	2 nd	74 dB
	3 rd	110 dB

The AD7764 and AD7765 sigma-delta devices are available to customers that require extra antialias protection. These devices sample internally at a rate of 20 MHz to achieve up to a maximum of 156 kHz or 312 kHz output data rate. This means that the first alias point of these devices when run at the maximum speeds are 19.921 MHz and 19.843 MHz, respectively.

POWER DISSIPATION

The AD7767/AD7767-1/AD7767-2 offer exceptional performance at ultralow power. Figure 43, Figure 44, and Figure 45 show how the current consumption of the AD7767/AD7767-1/AD7767-2 scales with the MCLK frequency applied to the device. Both the digital and analog currents scale as the MCLK frequency is reduced. The actual throughput of each of the AD7767/AD7767-1/AD7767-2 equals the MCLK frequency applied divided by the decimation rate employed by the device

in use. For instance, operating the AD7767 device with an MCLK of 800 kHz gives an output data rate of 100 kHz due to the decimate by 8 filtering.

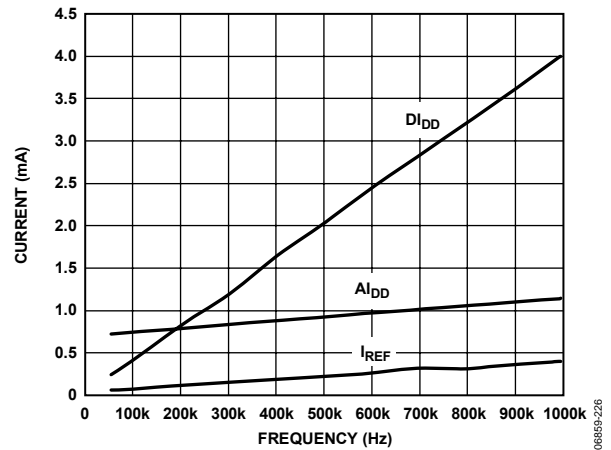

Figure 43. AD7767 Current vs. MCLK Frequency

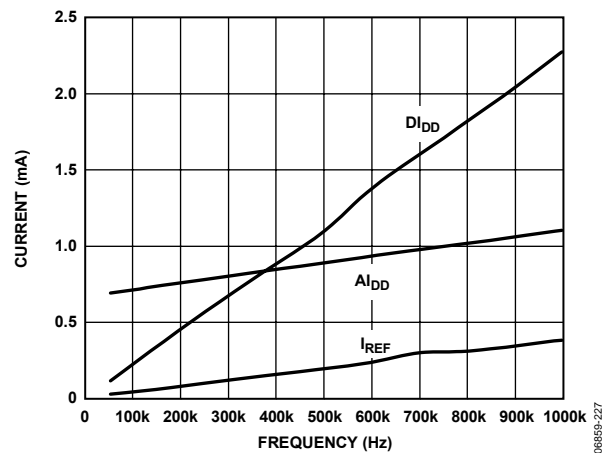

Figure 44. AD7767-1 Current vs. MCLK Frequency

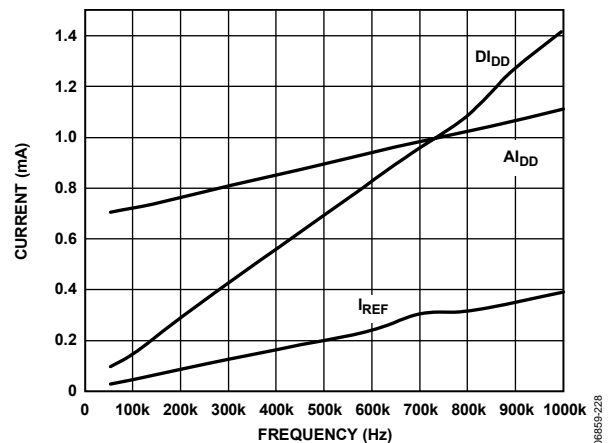

Figure 45. AD7767-2 Current vs. MCLK Frequency

AD7767

V_{REF+} INPUT SIGNAL

The AD7767/AD7767-1/AD7767-2 V_{REF+} pin is supplied with a 5 V input, which is generated by a low noise voltage reference. Either the ADR445 or the ADR425 can be used with the AD7767/AD7767-1/AD7767-2 device. This reference voltage input also acts as a power supply to the AD7767/AD7767-1/AD7767-2 device.

The output of the low noise voltage reference does not require a buffer; however, it is important to provide a passive filter network between the V_{OUT} pin of the voltage reference and the V_{REF+} input on the ADC. Figure 46 shows a reference signal network that can be used with both the ADR445 and the ADR425.

The 100 nF capacitor on the output of the ADR445 or ADR425 stabilizes the reference output voltage. The series resistor coupled with the other capacitive values on the reference acts as a low-pass filter. Figure 46 shows the optimal reference voltage input circuit.

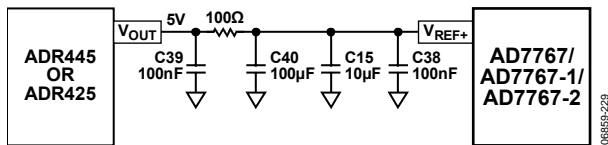

Figure 46. AD7767/AD7767-1/AD7767-2 Reference Filtering, ADR445 or ADR425 Circuit Topology

For the capacitor designated C40 in Figure 46, either an electrolytic or tantalum capacitor can be used. This capacitor acts as a reservoir of charge. Further decoupling capacitors are placed as close as possible to the V_{REF+} pin.

MULTIPLEXING ANALOG INPUT CHANNELS

The AD7767/AD7767-1/AD7767-2 can be used with a multiplexer configuration. As per any converter that uses a digital filtering block, the maximum switching rate, or output data rate per channel, is a function of the digital filter settling time.

A user multiplexing the analog inputs to a converter that employs a digital filter must wait the full digital filter settling time before a valid conversion result is achieved; at this point, the channel can be switched. After switching the channel, the full settling time must again be observed before a valid conversion result is available and the input is switched once more.

The AD7767 filter settling time equals 74 divided by the output data rate in use. The maximum switching frequency in a multiplexed application is therefore $1/(74/ODR)$, where the output data rate (ODR) is a function of the applied MCLK frequency and the decimation rate employed by the device in question. For example, applying a 1.024 MHz MCLK frequency to the AD7767 gives a maximum output data rate of 128 kHz, which in turn allows a 1.729 kHz multiplexer switching rate.

The AD7767-1 and the AD7767-2 employ digital filters with longer settling time to achieve greater precision; thus, the maximum switching frequency for these devices is 864 Hz and 432 Hz, respectively.

OUTLINE DIMENSIONS

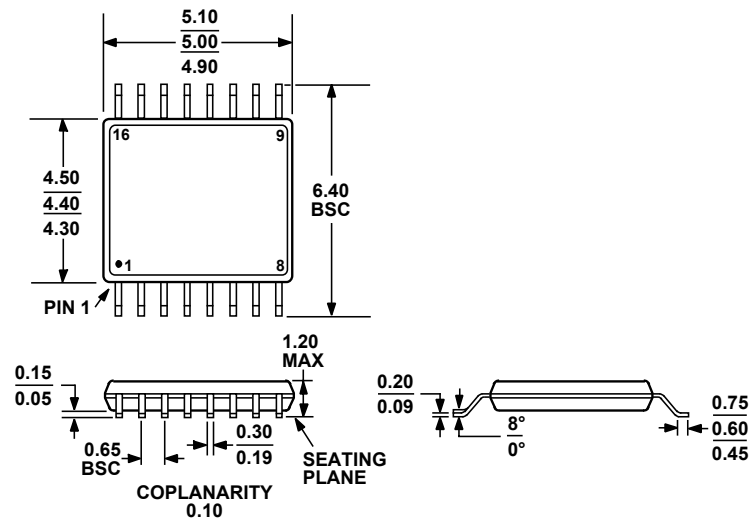

COMPLIANT TO JEDEC STANDARDS MO-153-AB

Figure 47. 16-Lead Thin Shrink Small Outline Package [TSSOP]
(RU-16)

Dimensions shown in millimeters

ORDERING GUIDE

Model	Temperature Range	Package Description	Package Option
AD7767BRUZ ¹	-40°C to +105°C	16-Lead Thin Shrink Small Outline Package [TSSOP]	RU-16
AD7767BRUZ-RL7 ¹	-40°C to +105°C	16-Lead Thin Shrink Small Outline Package [TSSOP]	RU-16
AD7767BRUZ-1 ¹	-40°C to +105°C	16-Lead Thin Shrink Small Outline Package [TSSOP]	RU-16
AD7767BRUZ-1-RL7 ¹	-40°C to +105°C	16-Lead Thin Shrink Small Outline Package [TSSOP]	RU-16
AD7767BRUZ-2 ¹	-40°C to +105°C	16-Lead Thin Shrink Small Outline Package [TSSOP]	RU-16
AD7767BRUZ-2-RL7 ¹	-40°C to +105°C	16-Lead Thin Shrink Small Outline Package [TSSOP]	RU-16
EVAL-AD7767EDZ ¹		Evaluation Board	
EVAL-AD7767-1EDZ ¹		Evaluation Board	
EVAL-AD7767-2EDZ ¹		Evaluation Board	
EVAL-CED1Z ¹		Converter Evaluation and Development Board	

¹ Z = RoHS Compliant Part.

AD7767

NOTES