

3.3 Volt ABT octal transparent latch (3–State)

74LVT373

FEATURES

- Designed for use in the 3.3V high–performance market
- Supports mixed–mode signal operation; 5V input and output voltages with 3.3V V_{CC}
- Bus–hold inputs eliminate the need for external pull-up resistors to hold unused pins
- Live insertion/extraction permitted
- No bus current loading when output is tied to 5V bus
- 8–bit transparent latch
- 3–State output buffers
- Zero-static power dissipation
- Pin and function compatibility with ABT
- AC and DC performance compatibility with ABT

- Latch–up protection exceeds 500mA per JEDEC JC40.2 Std 17
- ESD protection exceeds 2000 V per MIL STD 883 Method 3015 and 200 V per Machine Model

DESCRIPTION

The 74LVT373 device is designed specifically for low–voltage (3.3V) V_{CC} operation, but can provide a TTL interface to a 5V system environment.

The 74LVT373 high–performance BiCMOS device combines zero static and low dynamic power dissipation with high speed and high output drive.

The 74LVT373 device is an octal transparent latch coupled to eight 3–State output buffers. The two sections of the device are controlled

independently by Enable (E) and Output Enable (\overline{OE}) control gates.

The data on the D inputs are transferred to the latch outputs when the Latch Enable (E) input is High. The latch remains transparent to the data inputs while E is High, and stores the data that is present one setup time before the High-to-Low enable transition.

The 3–State output buffers are designed to drive heavily loaded 3–State buses, MOS memories, or MOS microprocessors. The active-Low Output Enable (\overline{OE}) controls all eight 3–State buffers independent of the latch operation.

When \overline{OE} is Low, the latched or transparent data appears at the outputs. When \overline{OE} is High, the outputs are in the High-impedance "OFF" state, which means they will neither drive nor load the bus.

QUICK REFERENCE DATA

SYMBOL	PARAMETER	CONDITIONS $T_{amb} = 25^{\circ}\text{C}; \text{GND} = 0\text{V}$	TYPICAL	UNIT
t_{PLH} t_{PHL}	Propagation delay Dn to Qn	$C_L = 50\text{pF}; V_{CC} = 5\text{V}$	4.2	ns
C_{IN}	Input capacitance	$V_I = 0\text{V}$ or V_{CC}	4	pF
C_{OUT}	Output capacitance	$V_I = 0\text{V}$ or V_{CC}	7	pF
I_{CCZ}	Total supply current	Outputs disabled; $V_{CC} = 5.5\text{V}$	50	μA

ORDERING INFORMATION

PACKAGES	TEMPERATURE RANGE	ORDER CODE	DRAWING NUMBER
20–Pin Plastic SOL	-40°C to $+85^{\circ}\text{C}$	74LVT373D	0172D
20–Pin Plastic SSOP	-40°C to $+85^{\circ}\text{C}$	74LVT373DB	1640B
20–Pin Plastic TSSOP	-40°C to $+85^{\circ}\text{C}$	74LVT373PW	TBD

PIN DESCRIPTION

PIN NUMBER	SYMBOL	FUNCTION
1	\overline{OE}	Output enable input (active-Low)
3, 4, 7, 8, 13, 14, 17, 18	D0-D7	Data inputs
2, 5, 6, 9, 12, 15, 16, 19	Q0-Q7	Data outputs
11	E	Enable input (active-High)
10	GND	Ground (0V)
20	V_{CC}	Positive supply voltage

3.3 Volt ABT octal transparent latch (3-State)

74LVT373

FUNCTION TABLE

INPUTS			INTERNAL REGISTER	OUTPUTS	OPERATING MODE
\overline{OE}	E	Dn		Q0 – Q7	
L	H	L	L	L	Enable and read register
L	H	H	H	H	
L	↓	i	L	L	Latch and read register
L	↓	h	H	H	
L	L	X	NC	NC	Hold
H	L	X	NC	Z	Disable outputs
H	H	Dn	Dn	Z	

H = High voltage level
 h = High voltage level one set-up time prior to the High-to-Low E transition
 L = Low voltage level
 l = Low voltage level one set-up time prior to the High-to-Low E transition
 NC = No change
 X = Don't care
 Z = High impedance "off" state
 ↓ = High-to-Low E transition

LOGIC DIAGRAM

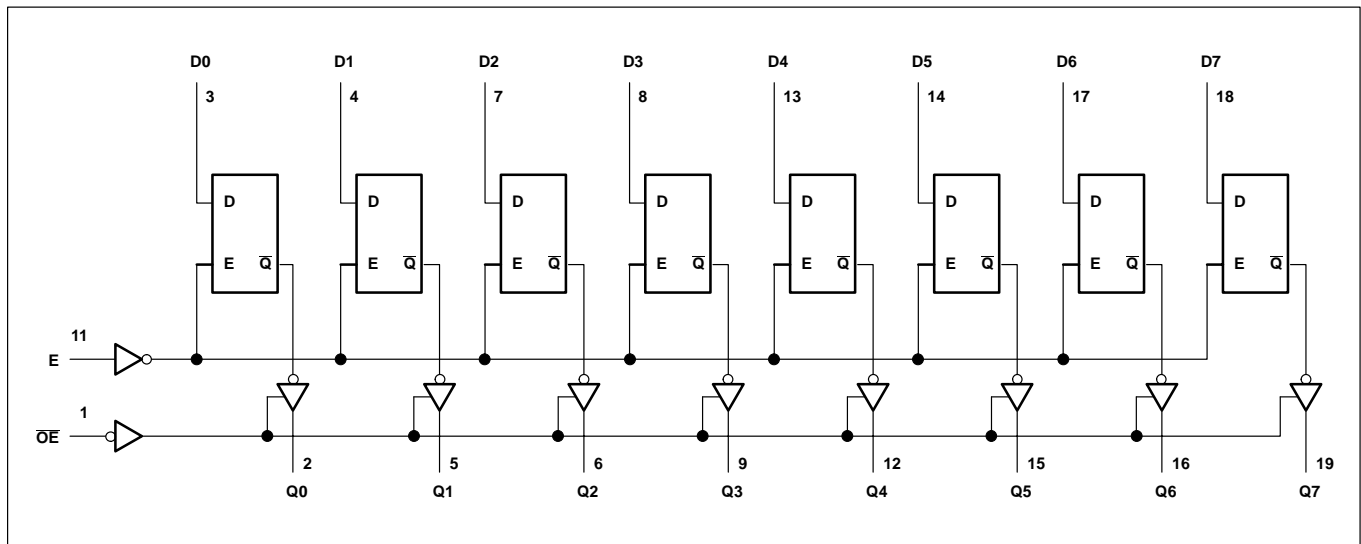

3.3 Volt ABT octal transparent latch (3–State)

74LVT373

ABSOLUTE MAXIMUM RATINGS^{1, 2}

SYMBOL	PARAMETER	CONDITIONS	RATING	UNIT
V _{CC}	DC supply voltage		–0.5 to +4.6	V
I _{IK}	DC input diode current	V _I < 0	–18	mA
V _I	DC input voltage ³		–1.2 to +5.5	V
I _{OK}	DC output diode current	V _O < 0	–50	mA
V _{OUT}	DC output voltage ³	output in Off or High state	–0.5 to +5.5	V
I _{OUT}	DC output current	output in Low state	64	mA
T _{stg}	Storage temperature range		–65 to 150	°C

NOTES:

- Stresses beyond those listed may cause permanent damage to the device. These are stress ratings only and functional operation of the device at these or any other conditions beyond those indicated under “recommended operating conditions” is not implied. Exposure to absolute–maximum–rated conditions for extended periods may affect device reliability.
- The performance capability of a high–performance integrated circuit in conjunction with its thermal environment can create junction temperatures which are detrimental to reliability. The maximum junction temperature of this integrated circuit should not exceed 150°C.
- The input and output voltage ratings may be exceeded if the input and output current ratings are observed.

RECOMMENDED OPERATING CONDITIONS

SYMBOL	PARAMETER	LIMITS		UNIT
		Min	Max	
V _{CC}	DC supply voltage	2.7	3.6	V
V _I	Input voltage	0	V _{CC}	V
V _{IH}	High-level input voltage	2.0		V
V _{IL}	Input voltage		0.8	V
I _{OH}	High-level output current		–32	mA
I _{OL}	Low-level output current		64	mA
Δt/Δv	Input transition rise or fall rate	0	10	ns/V
T _{amb}	Operating free-air temperature range	0	+70	°C

3.3 Volt ABT octal transparent latch (3-State)

74LVT373

DC ELECTRICAL CHARACTERISTICS

SYMBOL	PARAMETER	TEST CONDITIONS	LIMITS			UNIT
			Temp = -40°C to +85°C			
			MIN	TYP ¹	MAX	
V _{IK}	Input clamp voltage	V _{CC} = 2.7V; I _{IK} = -18mA			-1.2	V
V _{OH}	High-level output voltage	V _{CC} = 2.7 to 3.6V; I _{OH} = -100μA	V _{CC} -0.2			V
		V _{CC} = 2.7V; I _{OH} = -8mA	2.4			
		V _{CC} = 3.0V; I _{OH} = -32mA	2.0			
V _{OL}	Low-level output voltage	V _{CC} = 2.7V; I _{OL} = 100μA			0.2	V
		V _{CC} = 2.7V; I _{OL} = 24mA			0.5	
		V _{CC} = 3.0V; I _{OL} = 16mA			0.4	
		V _{CC} = 3.0V; I _{OL} = 32mA			0.5	
		V _{CC} = 3.0V; I _{OL} = 64mA			0.55	
I _I	Input leakage current	V _{CC} = 3.6V; V _I = V _{CC} or GND	Control pins		±1	μA
		V _{CC} = 0 or 3.6V; V _I = 5.5V			10	
		V _{CC} = 3.6V; V _I = 5.5V	Data pins ⁴		20	
		V _{CC} = 3.6V; V _I = V _{CC}			1	
		V _{CC} = 3.6V; V _I = 0			-5	
I _{OFF}	Output off current	V _{CC} = 0V; V _I or V _O = 0 to 4.5V			±100	μA
I _{HOLD}	Bus Hold current A or B ports	V _{CC} = 3V; V _I = 0.8V	75			μA
		V _{CC} = 3V; V _I = 2.0V	-75			μA
I _{EX}	Current into an output in the High state when V _O > V _{CC}	V _O = 5.5V; V _{CC} = 3.0V			100	μA
I _{CCH}	Quiescent supply current	V _{CC} = 3.6V; Outputs High, V _I = GND or V _{CC} , I _O = 0		0.13	0.19	mA
I _{CCL}		V _{CC} = 3.6V; Outputs Low, V _I = GND or V _{CC} , I _O = 0		3	12	
I _{CCZ}		V _{CC} = 3.6V; Outputs Disabled; V _I = GND or V _{CC} , I _O = 0		0.13	0.19	
ΔI _{CC}	Additional supply current per input pin ²	V _{CC} = 3V to 3.6V; One input at V _{CC} -0.6V, Other inputs at V _{CC} or GND			0.2	mA
I _{PU/PD}	Power up/down 3-State output current ³	V _{CC} ≤ 1.2V; V _O = 0.5V to V _{CC} ; V _I = GND or V _{CC} ; OE/OE = X			±100	μA
C _I	Input capacitance	V _I = 3V or 0		4		pF
C _O	Output capacitance	V _O = 3V or 0		11		pF

NOTES:

- All typical values are at V_{CC} = 3.3V and T_{amb} = 25°C.
- This is the increase in supply current for each input at the specified voltage level other than V_{CC} or GND
- This parameter is valid for any V_{CC} between 0V and 1.3V with a transition time of up to 10msec. From V_{CC} = 1.3V to V_{CC} = 3.3V ± 0.3V a transition time of 100μsec is permitted. X = Don't care.
- Unused pins at V_{CC} or GND.

3.3 Volt ABT octal transparent latch (3-State)

74LVT373

AC CHARACTERISTICS

GND = 0V; $t_R = t_F = 6\text{ns}$; $C_L = 50\text{pF}$; $R_L = 500\Omega$; $T_{\text{amb}} = -40^\circ\text{C}$ to $+85^\circ\text{C}$.

SYMBOL	PARAMETER	WAVEFORM	LIMITS				UNIT
			$V_{CC} = 3.3V \pm 0.3V$			$V_{CC} = 2.7V$	
			MIN	TYP ¹	MAX	MAX	
t_{PLH} t_{PHL}	Propagation delay An to Yn	NO TAG		2.7 2.9			ns
t_{PZH} t_{PZL}	Output enable time $\overline{OE}n$ to Yn	NO TAG		3.4 3.4			ns
t_{PHZ} t_{PLZ}	Output disable time $\overline{OE}n$ to Yn	NO TAG		3.7 2.6			ns

NOTE:

1. All typical values are at $V_{CC} = 3.3V$ and $T_{\text{amb}} = 25^\circ\text{C}$.

AC WAVEFORMS

$V_M = 1.5V$, $V_{IN} = \text{GND to } 3.0V$

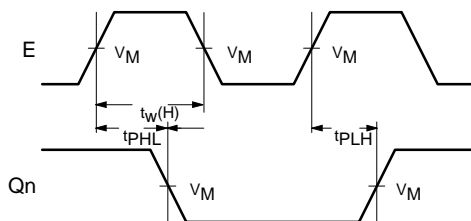

Waveform 1. Propagation Delay, Enable to Output, and Enable Pulse Width

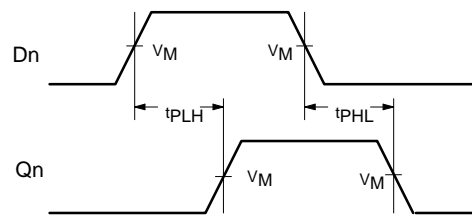

Waveform 2. Propagation Delay for Data to Outputs

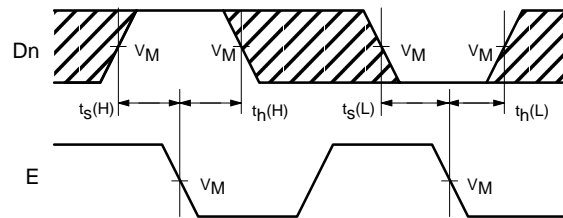

Waveform 3. Data Setup and Hold Times

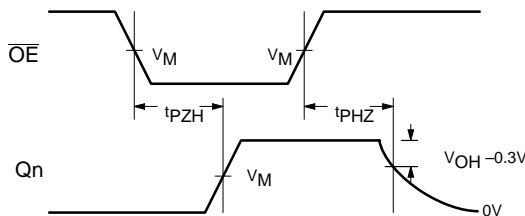

Waveform 4. 3-State Output Enable Time to High Level and Output Disable Time from High Level

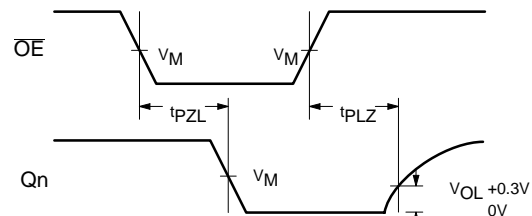

Waveform 5. 3-State Output Enable Time to Low Level and Output Disable Time from Low Level

NOTE: The shaded areas indicate when the input is permitted to change for predictable output performance.

3.3 Volt ABT octal transparent latch (3-State)

74LVT373

TEST CIRCUIT AND WAVEFORM

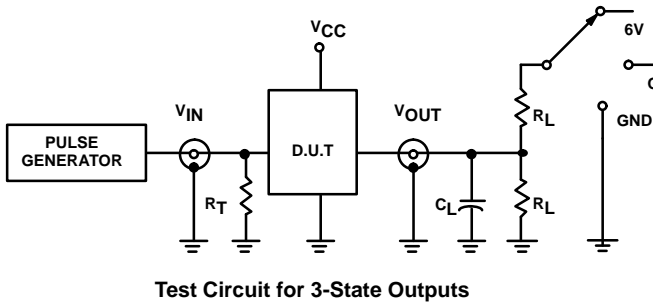

Test Circuit for 3-State Outputs

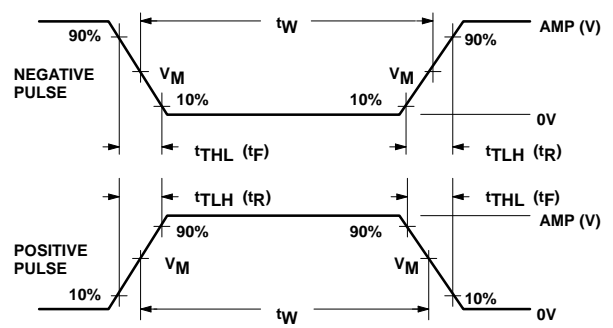

$V_M = 1.5V$
Input Pulse Definition

SWITCH POSITION

TEST	SWITCH
t_{PHZ}/t_{PZH}	GND
t_{PLZ}/t_{PZL}	6V
t_{PLH}/t_{PHL}	open

DEFINITIONS

R_L = Load resistor; see AC CHARACTERISTICS for value.

C_L = Load capacitance includes jig and probe capacitance; see AC CHARACTERISTICS for value.

R_T = Termination resistance should be equal to Z_{OUT} of pulse generators.

FAMILY	INPUT PULSE REQUIREMENTS				
	Amplitude	Rep. Rate	t_w	t_R	t_F
74LVT	$V_{CC}(\text{Min})$	$\leq 1\text{MHz}$	500ns	$\leq 2.5\text{ns}$	$\leq 2.5\text{ns}$