

8-bit REAL TIME CLOCK MODULE

RTC-64611/64613

- Built-in crystal unit allows adjustment-free efficient operation.
- 8-bit data bus and high speed access (85 nsec. max.).
- Provided with the same interface as S-RAM and battery backup function.
- Interruption of alarm of sec. to day and day of week and carry interruption.
- Reference signal selectable in a range of 1 Hz to 64 Hz (binary).
- Leap year automatically adjustable (gregorian calendar).
- With 1 Hz output terminal.
- Provided with START/STOP, 30 second adjust function.
- RTC-64613 uses a similar mounting method to that of a normal SMD IC.

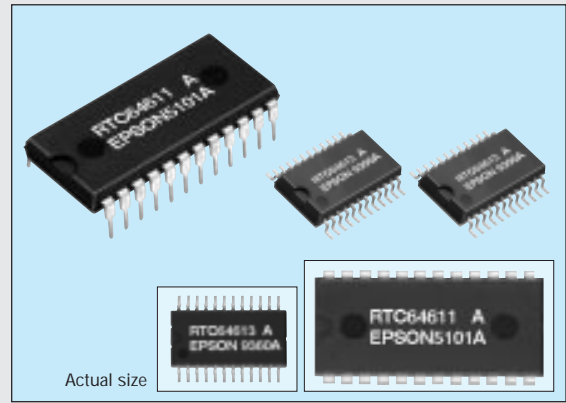

Specifications (characteristics)

Absolute Max. rating

Item	Symbol	Condition	Specifications	Unit
Power source voltage	V _{DD}	Ta=25°C	-0.5 to 7.0	V
Input voltage	V _{IN}		-0.5 to V _{DD} +0.3	
Storage temperature	T _{STG}	RTC-64611	-55 to +85	°C
		RTC-64613	-55 to +125	
Soldering condition	T _{SOL}	RTC-64611	Under 260°C within 10 sec. (lead part) (package should be less than 150°C)	
		RTC-64613	Twice at under 260°C within 10 sec. or under 230°C within 3 min.	

Operating range

Item	Symbol	Condition	Specifications	Unit
Operating voltage	V _{DD}	—	4.5 to 5.5	V
Operating temperature	T _{OPR}	—	-20 to +75	°C
Data holding voltage	V _{DH}	CS ≥ V _{DD} - 0.2V	2.0 to 4.5	V
CS data holding time	t _{CDR}	—	0 min.	
Operation restoring time	t _R	—	t _{rc} (85 ns.)	ns

Frequency characteristics and current consumption characteristics

Item	Symbol	Condition	Specifications	Unit	
Frequency tolerance	Δf/fo	Ta=25°C V _{DD} =5V	64611 A	+15/-5(5±10)	ppm
			64611 B	+55/-45(5±50)	
			64613 A	+25/-15(5±20)	
			64613	+55/-45(5±50)	
Frequency temperature characteristics		-10 to +70°C (25°C reference temperature)	+10/-120		
		-20 to +75°C (25°C reference temperature)	+10/-220		
Aging	f _a	V _{DD} =5V, Ta=25°C, first year	±5 max.	ppm/Y	
Shock resistance	S.R.	Three drops on a hard board from 75 cm or 3000G x 0.3ms x 1/2 sine wave x 3 directions	±10 max.	ppm	
Current consumption	I _{DD1}	No load	V _{DD} =5V	2 max.	mA
	I _{DD2}	CS ≥ 1.8V	V _{DD} =2V		μA

Unless otherwise stated, characteristics (specifications) shown in the above table are based on the rated operating temperature and voltage condition.

DC characteristics (V_{DD} = 5V ± 0.5V, Ta = -20 to +75°C)

Item	Symbol	Condition	V _{DD} = 5V ± 10%		V _{DD} = 2V		Unit
			Min.	Max.	Min.	Max.	
"H" input voltage	V _{IH}		2.2	V _{DD}	V _{DD} -0.2	V _{DD}	V
"L" input voltage	V _{IL}		-0.3	0.8	-0.3	0.2	V
Input leak current	I _{IN}			±2		±2	μA
Three-state leak current	I _{TSL}			±10		±10	μA
Output leak current	I _{LOH}						
"H" output voltage (except for 1 Hz, I _{RO})	V _{OH}	I _{OH} = -1mA	2.4	—	—	—	V
"L" output voltage	V _{OL}	I _{OL} = 2.1mA		0.4		—	V
Input capacity	C _{IN}	V _{IN} = 0V Ta = 25°C f = 1.0 MHz		12.5			pF
Output capacity	C _{OUT}						pF

Terminal connection

No.	Pin terminal	No.	Pin terminal
1	GND	13	I/O ₄
2	H-START/STOP	14	I/O ₅
3	I _{RO}	15	I/O ₆
4	1Hz	16	I/O ₇
5	A ₁	17	I/O ₈
6	A ₂	18	CS
7	A ₃	19	OE
8	A ₄	20	WE
9	I/O ₁	21	NC
10	I/O ₂	22	(V _{DD})
11	I/O ₃	23	(V _{DD})
12	GND	24	V _{DD}

• (V_{DD}) is to be same level as V_{DD}. Do not connect it to any external terminals.
• NC is not connected internally.

External dimensions

(Unit: mm)

• RTC-64611

• RTC-64613

Register table

Address	Data								Remarks
	b7	b6	b5	b4	b3	b2	b1	b0	
0		1 Hz	2 Hz	4 Hz	8 Hz	16 Hz	32 Hz	64 Hz	Counter
1	*	10-sec. digit			1-sec. digit				
2	*	10-min. digit			1-min. digit				
3	*	10-hour digit			1-hour digit				
4	*	Day-of-week digit			1-day digit				
5	*	10-day digit			1-month digit				
6	*	10-month digit			1-year digit				
7		1 Hz	2 Hz	4 Hz	8 Hz	16 Hz	32 Hz	64 Hz	Alarm register
8	ENB	10-sec. digit			1-sec. digit				
9		10-min. digit			1-min. digit				
A		10-hour digit			1-hour digit				
B		Day-of-week digit			1-day digit				
C		10-day digit			1-day digit				
D									Control register
E	Carry flag	*	Carry interruption enable	Alarm interruption enable	*	Alarm flag			
F	RAM7	RAM6	RAM5	RAM4	TEST ^{*1}	30-sec. adjustment	RESET	S.START /STOP	

*1 Be sure to enter "0" to TEST bit.

Supplement

Bit name	Description
* mark	Empty bit and unwriteable Recognized as "0" while reading
10-hour digit (b5)	Only for 24H mode
Under-sec. counter	Read only (unwriteable) Used as binary code data
Under-sec. alarm register	Used as binary code data
Sec.to year	Both counter and alarm register use BCD code
Day of week	Coded data is used EX: 0...Sunday 1...Monday 2...Tuesday 3...Wednesday 4...Thursday 5...Friday 6...Saturday

Note: Do not enter erroneous data for clock. This may result in time keeping error.

Block diagram

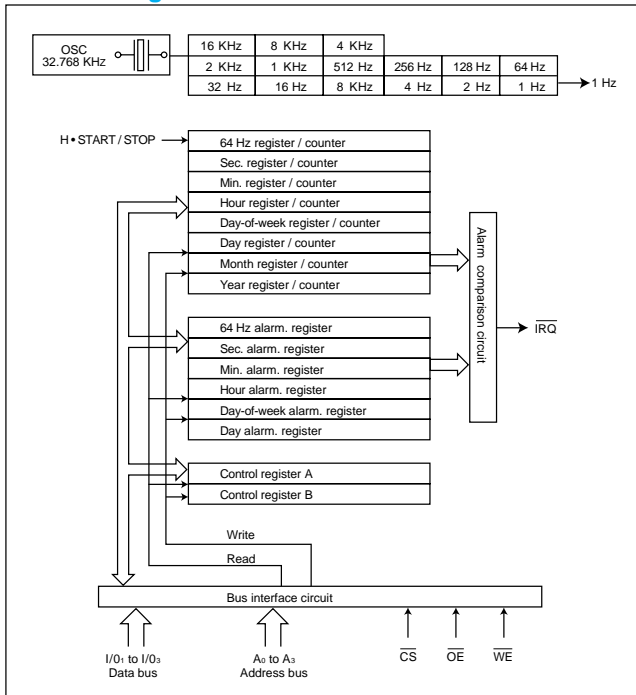

Switching characteristic

Measuring condition

- Input pulse level: 0.8 to 2.4V
- Input rise time, fall time: 5 nsec.
- IN/OUT timing pulse level: 1.5V
- Out put load: 1 TTL Gate +100pF

Read mode

Item	Symbol	Min.	Max.	Unit
Read cycle time	t _{RC}	85	—	ns
Address access time	t _{AA}	—	85	
Chip select access time	t _{ACS}	—	—	
Output enable access time	t _{OE}	—	45	
Output hold time	t _{OH}	10	—	
Chip select / output set time	t _{CLZ}	—	—	
Output enable / output set time	t _{OLZ}	5	—	
Chip deselect / output floating	t _{CHZ}	—	—	
Output disable / output floating	t _{OHZ}	0	35	

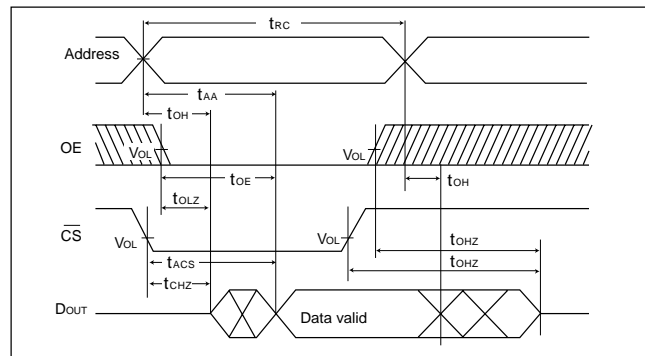

Write mode

Item	Symbol	Min.	Max.	Unit
Write cycle time	t _{WC}	85	—	ns
Chip select time	t _{CS}	75	—	
Address valid time	t _{AV}	—	—	
Address setup time	t _{AS}	0	—	
Write pulse time	t _{WP}	60	—	
Address holding time	t _{WR}	10	—	
WE output floating	t _{WHZ}	0	35	
Input data set time	t _{DW}	40	—	
Input data hold time	t _{DH}	0	—	
Output disable / output floating	t _{OHZ}	—	35	
WE output set time	t _{OW}	5	—	

