

DATA SHEET



PCF8881

**132 × 132 RGB single chip TFT
driver with DC-to-DC converter**

Objective specification

2004 Aug 10

**132 × 132 RGB single chip TFT driver
with DC-to-DC converter**

PCF8881**CONTENTS**

1	GENERAL DESCRIPTION
2	FEATURES
3	ORDERING INFORMATION
4	QUICK REFERENCE DATA
4.1	Output load model
5	BLOCK DIAGRAM
6	LIMITING VALUES
7	HANDLING
8	APPLICATION INFORMATION
9	PIN CONFIGURATION
10	DATA SHEET STATUS
11	DEFINITIONS
12	DISCLAIMERS
13	PURCHASE OF PHILIPS I ² C COMPONENTS

132 × 132 RGB single chip TFT driver with DC-to-DC converter

PCF8881

1 GENERAL DESCRIPTION

The PCF8881 is a low-power single chip TFT LCD driver with integrated source driver, gate driver, display RAM, timing control and DC-to-DC converter. The IC is a single chip solution with a minimum number of external components (capacitors).

The PCF8881 has 396 source and 132 gate outputs (132 × RGB Sources × 132 Gates). The integrated display RAM has a capacity of 279 kbits (132 Sources × 16 bits × 132 Gates). The PCF8881 can drive a 132 RGB column × 132 line LCD panel with 65 kbyte colours when using the internal RAM.

2 FEATURES

- Low-power single chip Thin Film Transistor (TFT) LCD driver with integrated source driver, gate driver, display RAM, timing controller and DC-to-DC converter
- 528 outputs (132 × 132 RGB)
- 132 gate driver with up to 25 V output level
- Gate driver features:
 - Integrated programmable voltage generator for 2 gate levels (max. 25 V)
 - programmable scan direction for different glass routing
 - special driving modes (interlace, dancing).
- Integrated voltage generator for source driver (4.8 V max., –4.8 V min.)
- On-chip 132 × 132 × 16-bit display data RAM for 65 kbyte colours
- On-chip oscillator and timing controller
- On-chip common electrode voltage generator



- 4 predefined grey-level curves according to 4 gamma values
- Programmable grey-level curve with 2 × 16 externally available tab pins
- Integrated temperature compensation
- Display features:
 - Programmable frame refresh rate between 5 Hz and 85 Hz in 5 Hz steps
 - User selectable line or frame inversion
 - All pixels on/off modes
 - 8, 256, 4 k, and 65 k colour modes from look-up table (LUT).
- Interfaces:
 - 8-bit parallel interface (Intel 8080 and Motorola 68xx) with 16, 12 and 8-bpp resolution
 - extended 16-bit parallel interface (Intel 8080 or Motorola 68xx)
 - 3-line serial (9 bits per word).
- Digital power supply: 1.65 V to 1.95 V
- Analog power supply: 2.6 V to 2.9 V
- All driver settings are stored using a One Time Programming (OTP) block
- Slim chip layout, suitable for Chip-On-Glass (COG)
- Output staggered with 35 μm pitch.

3 ORDERING INFORMATION

TYPE NUMBER	PACKAGE		
	NAME	DESCRIPTION	VERSION
PCF8881U/2DA/1	–	chip with bumps in tray	–

132 × 132 RGB single chip TFT driver with DC-to-DC converter

PCF8881

4 QUICK REFERENCE DATA

$V_{DDDD} = 2.7\text{ V to }3.3\text{ V}$; $V_{DDA} = 2.7\text{ V to }3.3\text{ V}$; $V_{SSD} = V_{SSA} = 0\text{ V}$; $T_{\text{amb}} = -40\text{ }^{\circ}\text{C to }+70\text{ }^{\circ}\text{C}$; $f_{\text{osc}} = 227.8\text{ kHz}$; data = 00h.

SYMBOL	PARAMETER	CONDITION	MIN.	TYP.	MAX.	UNIT
Supplies						
V_{DDDD}	logic supply voltage range		1.65	1.8	1.95	V
V_{DDA}	analog supply voltage range		2.6	2.75	2.9	V
V_{SSD}	logic ground level			0.0		V
V_{SSA}	analog ground level			0.0		V
Logic Inputs						
V_{IH}	HIGH level input voltage		$0.7V_{SSD}$		V_{DDDD}	V
V_{IL}	LOW level input voltage		0		$0.3V_{DDDD}$	V
I_L	input leakage current	$V_I = V_{DDDD}$ or V_{SSD}	-1		+1	μA
Logic Outputs						
V_{OH}	HIGH level output voltage	current = 1 mA	$0.8V_{DDDD}$		V_{DDDD}	V
V_{OL}	LOW level output voltage	current = 1 mA	V_{SSD}		$0.2V_{SSD}$	V
Current consumption analog and logic						
Power-down						
I_{DDD}	logic current consumption			0	0	μA
I_{DDA}	analog current consumption			10	20	μA

4.1 Output load model

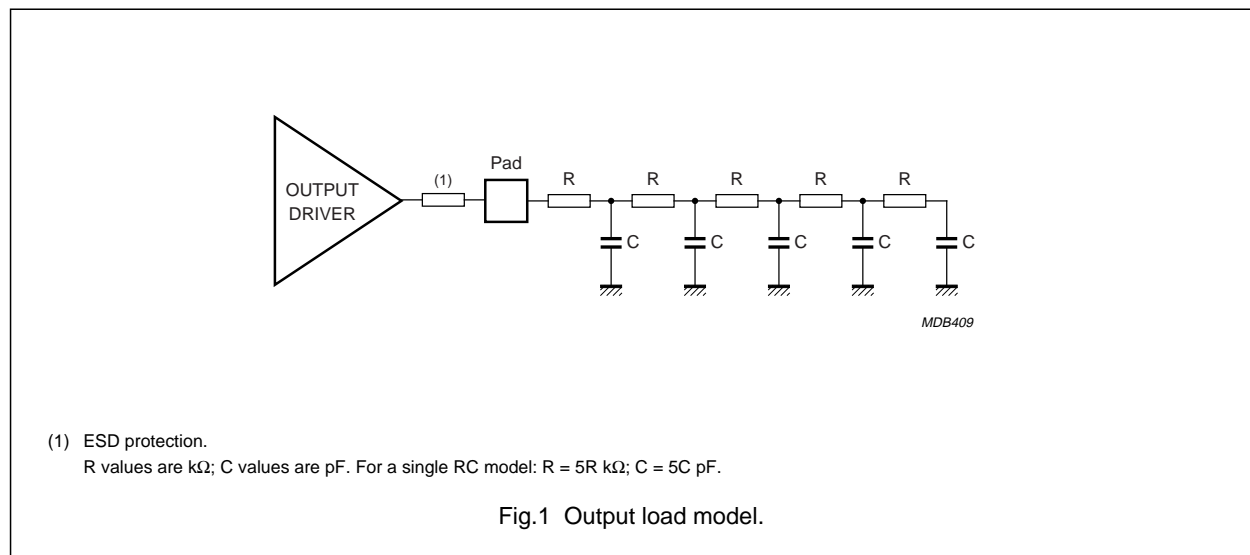

132 × 132 RGB single chip TFT driver
with DC-to-DC converter

PCF8881

5 BLOCK DIAGRAM

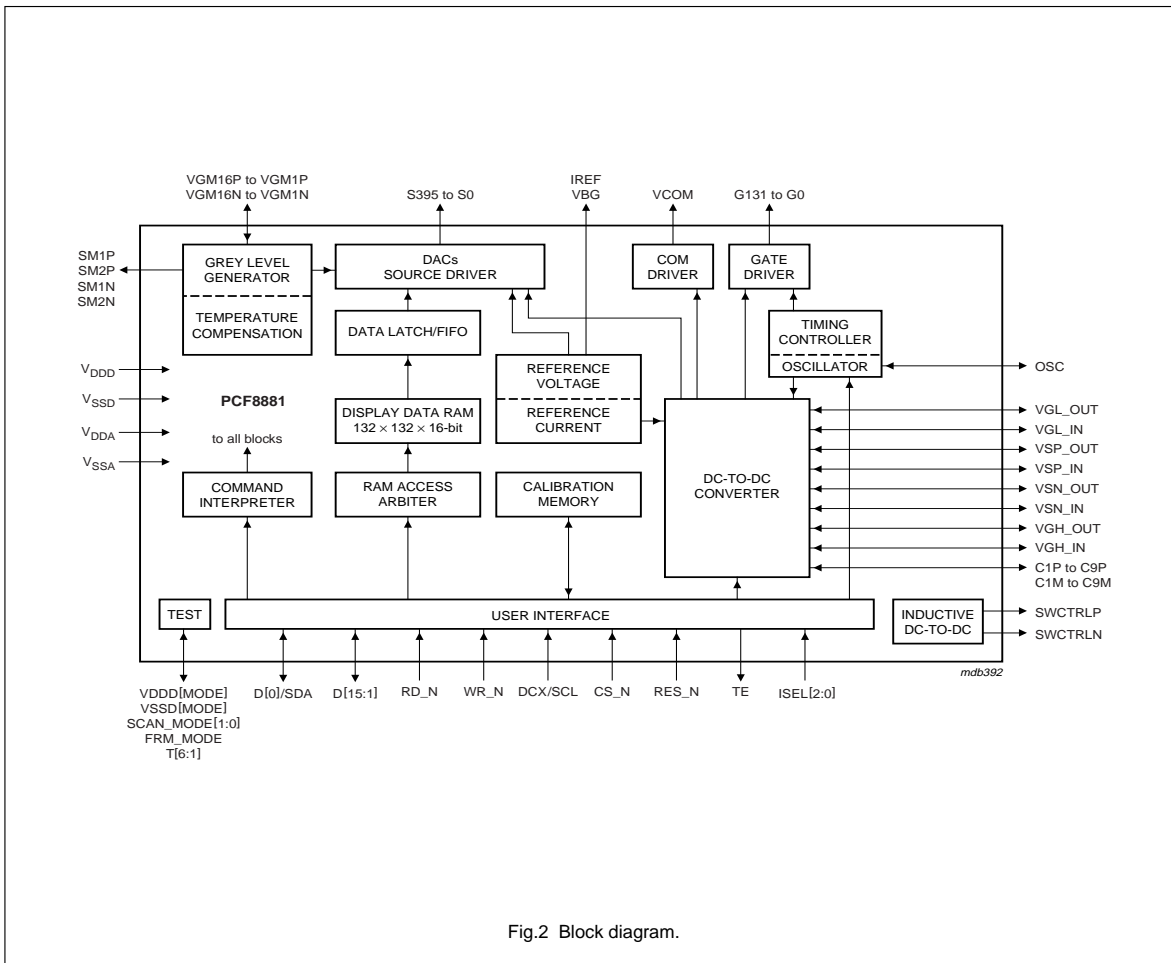

132 × 132 RGB single chip TFT driver with DC-to-DC converter

PCF8881

6 LIMITING VALUES

In accordance with the Absolute Maximum Rating System (IEC 60134); notes 1, 2 and 3.

SYMBOL	PARAMETER	MIN.	MAX.	UNIT
V_{DDD}	logic supply voltage	-0.5	+4.0	V
V_{DDA}	analog supply voltage	-0.5	+5.5	V
V_{GMA}	grey level reference voltage range	-0.5	+5.5	V
V_I / V_O	input / output voltage (any input / output)	-0.5	$V_{DDD} + 0.5$	V
I_I	DC input current	-10	+10	mA
I_O	DC output current	-10	+10	mA
$I_{V_{DDD}}, I_{V_{DDA}}, I_{V_{SSD}}, I_{V_{SSA}}$	supply current	-50	+50	mA
$P_{\text{tot(pack)}}$	total power dissipation per package	-	tbd	mW
$P_{\text{/out}}$	power dissipation per output	-	tbd	mW
T_{stg}	storage temperature; note 4	-55	+125	°C
T_{oper}	operating temperature	-40	+85	°C

Note

1. Stresses above the given values will cause permanent damage to the device.
2. Parameters are valid over the operating temperature range unless otherwise specified.
3. All voltages are with respect to V_{SS} unless otherwise specified.
4. The storage temperature specifies a safe temperature range for the chip when not powered.

7 HANDLING

Inputs and outputs are protected against electrostatic discharge in normal handling. However it is good practice to take normal precautions appropriate to handling MOS devices (see "*Handling MOS devices*").

132 × 132 RGB single chip TFT driver
with DC-to-DC converter

PCF8881

8 APPLICATION INFORMATION

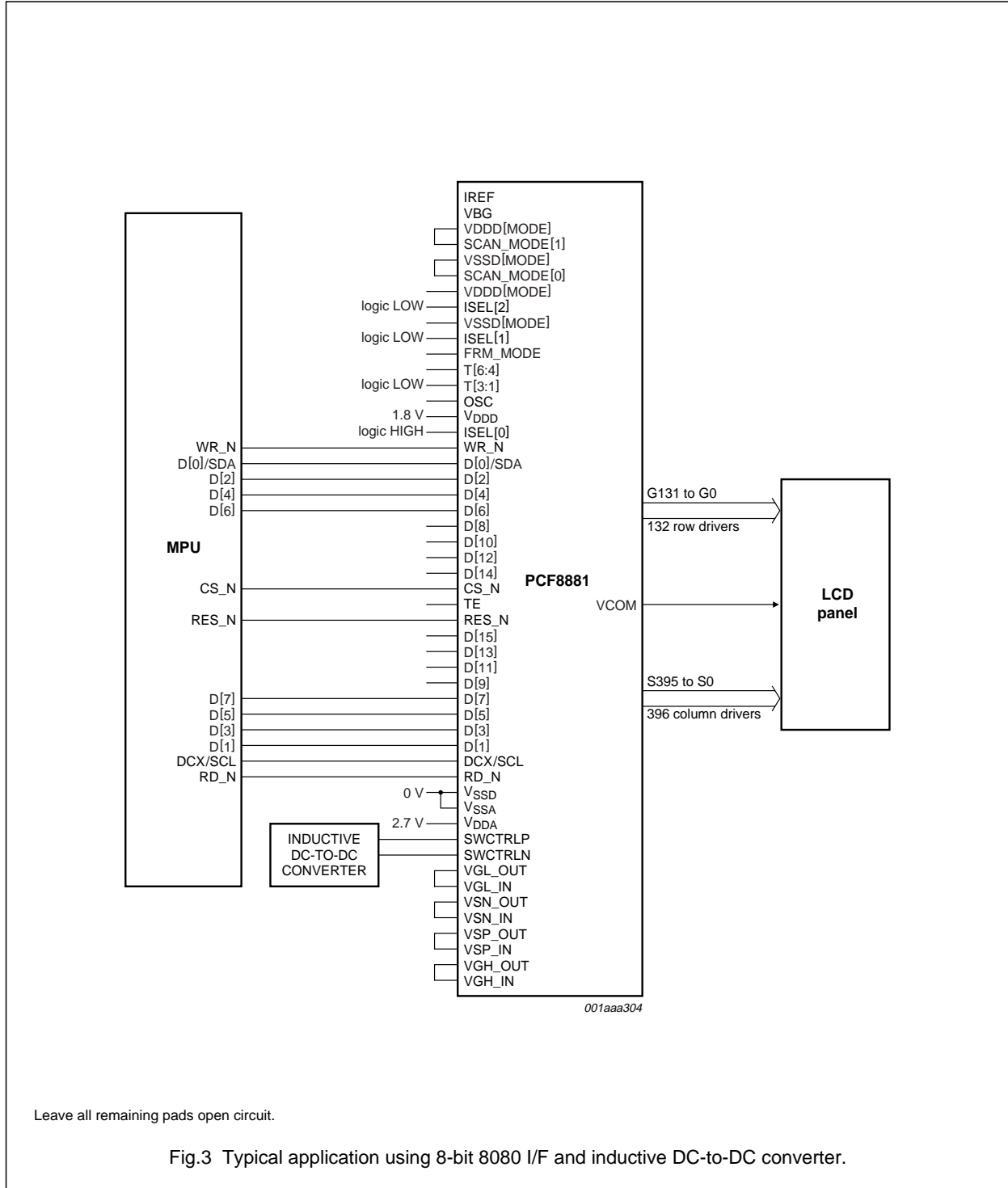

132 × 132 RGB single chip TFT driver
with DC-to-DC converter

PCF8881

9 PIN CONFIGURATION

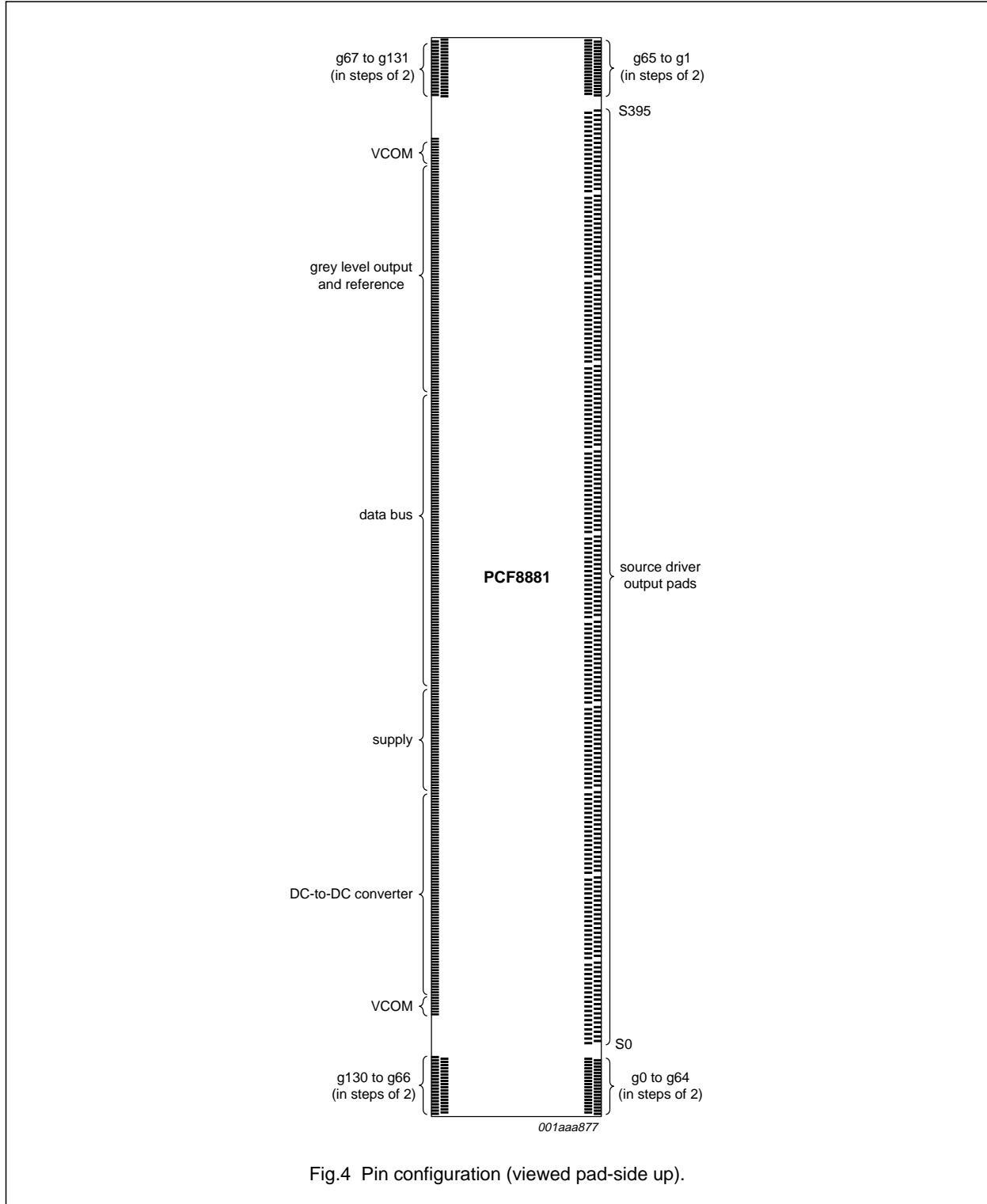

Fig.4 Pin configuration (viewed pad-side up).

132 × 132 RGB single chip TFT driver with DC-to-DC converter

PCF8881

10 DATA SHEET STATUS

LEVEL	DATA SHEET STATUS ⁽¹⁾	PRODUCT STATUS ⁽²⁾⁽³⁾	DEFINITION
I	Objective data	Development	This data sheet contains data from the objective specification for product development. Philips Semiconductors reserves the right to change the specification in any manner without notice.
II	Preliminary data	Qualification	This data sheet contains data from the preliminary specification. Supplementary data will be published at a later date. Philips Semiconductors reserves the right to change the specification without notice, in order to improve the design and supply the best possible product.
III	Product data	Production	This data sheet contains data from the product specification. Philips Semiconductors reserves the right to make changes at any time in order to improve the design, manufacturing and supply. Relevant changes will be communicated via a Customer Product/Process Change Notification (CPCN).

Notes

1. Please consult the most recently issued data sheet before initiating or completing a design.
2. The product status of the device(s) described in this data sheet may have changed since this data sheet was published. The latest information is available on the Internet at URL <http://www.semiconductors.philips.com>.
3. For data sheets describing multiple type numbers, the highest-level product status determines the data sheet status.

11 DEFINITIONS

Short-form specification — The data in a short-form specification is extracted from a full data sheet with the same type number and title. For detailed information see the relevant data sheet or data handbook.

Limiting values definition — Limiting values given are in accordance with the Absolute Maximum Rating System (IEC 60134). Stress above one or more of the limiting values may cause permanent damage to the device. These are stress ratings only and operation of the device at these or at any other conditions above those given in the Characteristics sections of the specification is not implied. Exposure to limiting values for extended periods may affect device reliability.

Application information — Applications that are described herein for any of these products are for illustrative purposes only. Philips Semiconductors make no representation or warranty that such applications will be suitable for the specified use without further testing or modification.

12 DISCLAIMERS

Life support applications — These products are not designed for use in life support appliances, devices, or systems where malfunction of these products can reasonably be expected to result in personal injury. Philips Semiconductors customers using or selling these products for use in such applications do so at their own risk and agree to fully indemnify Philips Semiconductors for any damages resulting from such application.

Right to make changes — Philips Semiconductors reserves the right to make changes in the products - including circuits, standard cells, and/or software - described or contained herein in order to improve design and/or performance. When the product is in full production (status 'Production'), relevant changes will be communicated via a Customer Product/Process Change Notification (CPCN). Philips Semiconductors assumes no responsibility or liability for the use of any of these products, conveys no licence or title under any patent, copyright, or mask work right to these products, and makes no representations or warranties that these products are free from patent, copyright, or mask work right infringement, unless otherwise specified.

132 × 132 RGB single chip TFT driver
with DC-to-DC converter

PCF8881

13 PURCHASE OF PHILIPS I²C COMPONENTS



Purchase of Philips I²C components conveys a license under the Philips' I²C patent to use the components in the I²C system provided the system conforms to the I²C specification defined by Philips. This specification can be ordered using the code 9398 393 40011.

Philips Semiconductors – a worldwide company

Contact information

For additional information please visit <http://www.semiconductors.philips.com>. Fax: **+31 40 27 24825**

For sales offices addresses send e-mail to: sales.addresses@www.semiconductors.philips.com.

© Koninklijke Philips Electronics N.V. 2004

SCA76

All rights are reserved. Reproduction in whole or in part is prohibited without the prior written consent of the copyright owner.

The information presented in this document does not form part of any quotation or contract, is believed to be accurate and reliable and may be changed without notice. No liability will be accepted by the publisher for any consequence of its use. Publication thereof does not convey nor imply any license under patent- or other industrial or intellectual property rights.

Printed in The Netherlands

R15/02/pp11

Date of release: 2004 Aug 10

Document order number: 9397 750 12473

Let's make things better.

**Philips
Semiconductors**



PHILIPS