



PCF87852

Bluetooth baseband controller

Rev. 01 — 23 April 2004

Preliminary data

1. General description

The PCF87852 combines the Bluetooth™ protocol stack, Link Controller (LC), Link Manager (LM), and Host Controller Interface (HCI) firmware of the Bluetooth system specification in a single IC with embedded software. Together with an RF module, a few external components and an antenna it forms a Bluetooth system. In most cases this module will be attached to a host, for example a GSM baseband controller or a PC processor. The PCF87852 may also be used for embedded Bluetooth applications by running the upper software layers also from the on-chip memory. Together with an external voice codec a Bluetooth headset application can be realized.

The industry standard ARM7TDMI™ microcontroller with low power consumption is integrated together with ROM memory and SRAM. There are no provisions for external controllers to directly access on-chip data memory. Communication with an external host, for example a PC, GSM or PDA, is handled via the HCI.

Industry standard interfaces such as I²C-bus™, PCM and IOM® are supported by on-chip hardware. Additionally, a UART interface is available that can be used as the Bluetooth host controller interface.

The Bluetooth controller consists of a number of functional blocks that operate under control of the embedded microcontroller. The microcontroller has access to these blocks via the AMBA System Bus (ASB) and the VLSI Peripheral Bus (VPB).

The PCF87852 is designed to be used together with an RF IC as low-cost, low-power, radio-based cable replacement or wireless link. This link will be the basis for PCs, telephones, PDAs and peripherals to communicate together on an ad-hoc basis. It will replace cables and enables a wireless personal network.

The PCF87852 is especially suited for applications without the need for analog voice input or output, e.g. cellular telephones or computing platforms.

2. Features

2.1 Baseband hardware

- Embedded ARM7TDMI microprocessor
- 224 kbytes ROM memory
- 38 kbytes SRAM memory
- 8 kbytes internal data RAM (IRAM) for Bluetooth controller
- Watchdog timer
- Two 32-bit system timers



PHILIPS

- Bluetooth controller including scrambling, CRC generation and checking, FEC encoding and decoding and ciphering according the “*Specification of the Bluetooth System, Version 1.1*”
- Bluetooth connections supporting:
 - ◆ Maximum 3 active connections (ACL)
 - ◆ One voice connection (SCO).
- CVSD transcoder
- RF interface
- RSSI measurement
- On-chip 1.8 V voltage regulator
- 8-bit D/A and A/D conversion for various purposes; e.g. PA control
- Power-on reset
- System clock crystal oscillator
- Low-power crystal oscillator for a low-frequency clock input
- System clock request signal for control of external clock source
- Microprocessor interfaces including UART, I²C-bus, combined PCM/IOM and general purpose I/O-pins
- Patch mechanism for code updates and corrections.

2.2 Firmware

- Interface drivers
- Bluetooth controller driver
- Link Controller (LC)
- Link Manager (LM)
- Host Controller Interface (HCI)
- L2CAP, RFCOMM and SDP
- Small profiles and application software (i.e Bluetooth headset).

2.3 General

- Core and interface supply: 1.8 V; RF interface supply: 2.7 V to 3.4 V
- Operating temperature range: –40 °C to +85 °C
- Package: LFBGA73 (7 × 7 mm² and 0.5 mm pitch).

3. Applications

- Cell phones and smart phones
- Computing applications (PC, notebook and PDA)
- Cellular accessories (Bluetooth headsets).

4. Quick reference data

Table 1: Quick reference data

Symbol	Parameter	Conditions	Min	Typ	Max	Unit
Supplies						
V _{SS}	ground voltage		[1] -	0	-	V
V _{DDCO1}	first core supply voltage		[2] 1.65	1.8	1.95	V
V _{DDCO2}	second core supply voltage		[2] 1.65	1.8	1.95	V
V _{DDIORF}	RF interface supply voltage		[2][3][4] 1.65	3.0	3.6	V
V _{DDIO18}	1.8 V I/O supply voltage		[2] 1.65	1.8	1.95	V
V _{DDIOV}	variable I/O supply voltage		[2] 1.65	3.0	3.6	V
V _{DDA}	analog supply voltage		[2] 1.65	1.8	1.95	V
V _{DDO}	oscillator supply voltage		[2][5] 1.65	1.8	1.95	V
Power consumption^[6]						
I _{DD(on)}	operating supply current for an active ACL link and continuous DM1 and DH1 mode	I _{DD} = I _{DDC} + I _{DDA} ; ARM active; V _{DDC} = V _{DDA} = 1.8 V	-	13	-	mA
I _{DDIORF(tx)}	RF interface supply current in transmit mode	V _{DDIORF} = 3.0 V	-	125	-	μA
I _{DD(lp)}	low-power supply current in low power mode	I _{DD} = I _{DDC} + I _{DDA} ; ARM off; DCXO off; LPO on (32.768 kHz)	-	40	-	μA
I _{DD(off)}	off mode supply current for lowest possible current	I _{DD} = I _{DDC} + I _{DDA} ; ARM off; clocks off	[7] -	30	-	μA
Digital I/O pins						
I/O pins at V_{DDIORF}						
V _{IH}	HIGH-level input voltage		2.0	-	V _{DDIORF}	V
V _{IL}	LOW-level input voltage		0	-	0.8	V
V _{OH}	HIGH-level output voltage	I _{OH} = 4 mA	V _{DDIORF} - 0.4	-	-	V
V _{OL}	LOW-level output voltage	I _{OL} = 4 mA	-	-	0.4	V
I/O pins at V_{DDIO18}						
V _{IH}	HIGH-level input voltage		0.7V _{DDIO18}	-	V _{DDIO18}	V
V _{IL}	LOW-level input voltage		0	-	0.3V _{DDIO18}	V
V _{hys}	hysteresis voltage		-	0.3V _{DDIO18}	-	V
V _{OH}	HIGH-level output voltage	I _{OH} = 4 mA	V _{DDIO18} - 0.4	-	-	V
V _{OL}	LOW-level output voltage	I _{OL} = 4 mA	-	-	0.4	V
I/O pins at V_{DDIOV}						
V _{IH}	HIGH-level input voltage		0.7V _{DDIOV}	-	V _{DDIOV}	V
V _{IL}	LOW-level input voltage		0	-	0.3V _{DDIOV}	V
V _{hys}	hysteresis voltage		-	0.3V _{DDIOV}	-	V
V _{OH}	HIGH-level output voltage	I _{OH} = 3 mA	V _{DDIOV} - 0.4	-	-	V
V _{OL}	LOW-level output voltage	I _{OL} = 3 mA	-	-	0.4	V

[1] Applies to all 0 V ground reference pins: V_{SSIORF}, V_{SSCO1}, V_{SSCO2}, V_{SSIO18}, V_{SSIOV}, V_{SSA} and V_{SSO}.

[2] It must be insured that the supply rise on each of the supply pins from 0 V to 1.1 V is shorter than 5 ms.

- [3] V_{DDIORF} is only tested at 2.7 V to 3.4 V.
 [4] $V_{DDIORF} = V_{DDIOV}$.
 [5] I²C-bus is only functional for voltages between 3.0 V and 3.6 V.
 [6] The power consumptions are very dependent on the software settings and can vary a lot.
 [7] CMOS leakage current. All blocks are disabled except the bias currents of the band gap reference and the power-on reset circuit.

Table 2: Typical power consumption figures of the PCF87852 in combination with BGB101 radio module

Symbol ^[1]	Domain	Typ	Unit
SCO and HV3 packet	^[2] 1.80 V	13.0	mA
	2.85 V	12.0	mA
	total P	57.6	mW
ACL, DM1 or DH1 packets and bidirectional data	^[2] 1.80 P	12.6	mA
	2.85 V	10.0	mA
	total P	51.2	mW
ACL, DM5 or DH5 packet transmit and NULL packet receive	^[2] 1.80 V	12.6	mA
	2.85 V	26.0	mA
	total P	96.8	mW
ACL, DM5 or DH5 packet receive and NULL packet transmit	^[2] 1.80 V	12.6	mA
	2.85 V	32.0	mA
	total P	113.9	mW
ACL, sniff mode and external 32 kHz ($T_{sniff} = 500$ ms)	^[3] 1.80 V	0.32	mA
	2.85 V	0.40	mA
	total P	1.71	mW
ACL, sniff mode and internal 32 kHz ($T_{sniff} = 500$ ms)	^[4] 1.80 V	0.65	mA
	2.85 V	0.40	mA
	total P	2.31	mW
Low power page/inquiry scan and external 32 kHz	^[3] 1.80 V	0.23	mA
	2.85 V	0.42	mA
	total P	1.61	mW
Low power page/inquiry scan and internal 32 kHz	^[4] 1.80 V	0.55	mA
	2.85 V	0.42	mA
	total P	2.19	mW

- [1] All measurements performed on sampling basis with HCI firmware loaded in the PCF87852 internal ROM.
 [2] Measurements are done with the 13 MHz oscillator in slave mode.
 [3] Measurements are done with a 32.768 kHz crystal connected to generate the Bluetooth low power clock.
 [4] Measurements are done with a 13 MHz crystal connected and the Bluetooth low power clock derived from the 13 MHz.

5. Ordering information

Table 3: Ordering information

Type number	Package		
	Name	Description	Version
PCF87852E	LFBGA73	plastic low profile fine-pitch ball grid array package; 73 balls; body 7 × 7 × 1.05 mm	SOT751-1

6. Block diagram

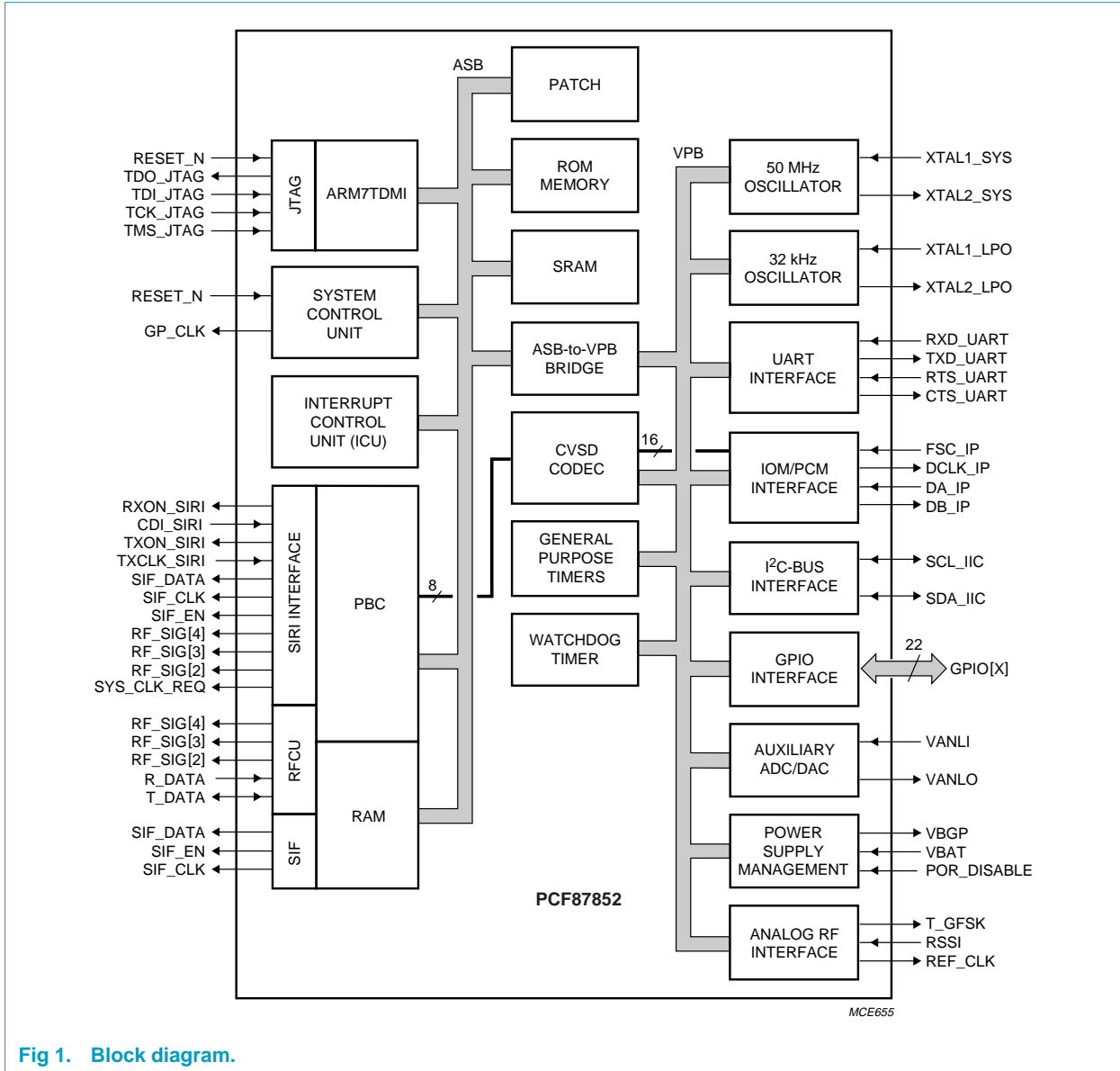

Fig 1. Block diagram.

7. Functional description

The PCF87852 is designed to be used as a low-cost, low-power radio-based cable replacement, or wireless link. This link will be the basis for PCs, telephones, PDAs headsets and peripherals to communicate together on an ad-hoc basis. It is designed to handle the Bluetooth specification.

The PCF87852 is intended to combine the Bluetooth protocol stack, link controller, link manager, HCI Firmware and radio of the Bluetooth system specification in one IC with embedded software. **Figure 2** shows a typical example of the PCF87852 in its environment. Together with few external components and an antenna it forms a Bluetooth system. In most cases this system will be attached to a host, for example a GSM baseband controller or a PC processor.

The industry standard ARM7TDMI microcontroller with low power consumption per MHz is integrated. There is a ROM memory and a static RAM on-chip. There are no provisions for external controllers to directly access on-chip data memories. Communication with an external host, for example a PC, GSM or PDA, is handled via the HCI.

The PCF87852 is able to run the complete Bluetooth application up to HCI.

A number of industry standard interfaces such as IOM/PCM, I²C-bus, and UART are supported by on-chip hardware to act as possible host interfaces.

The Bluetooth link controller consists of a number of functional blocks that operate under control of the embedded microcontroller. The microcontroller has access to these blocks via the AMBA System Bus (ASB) and VLSI Peripheral Bus (VPB).

Figure 1 shows the various blocks and their interconnections.

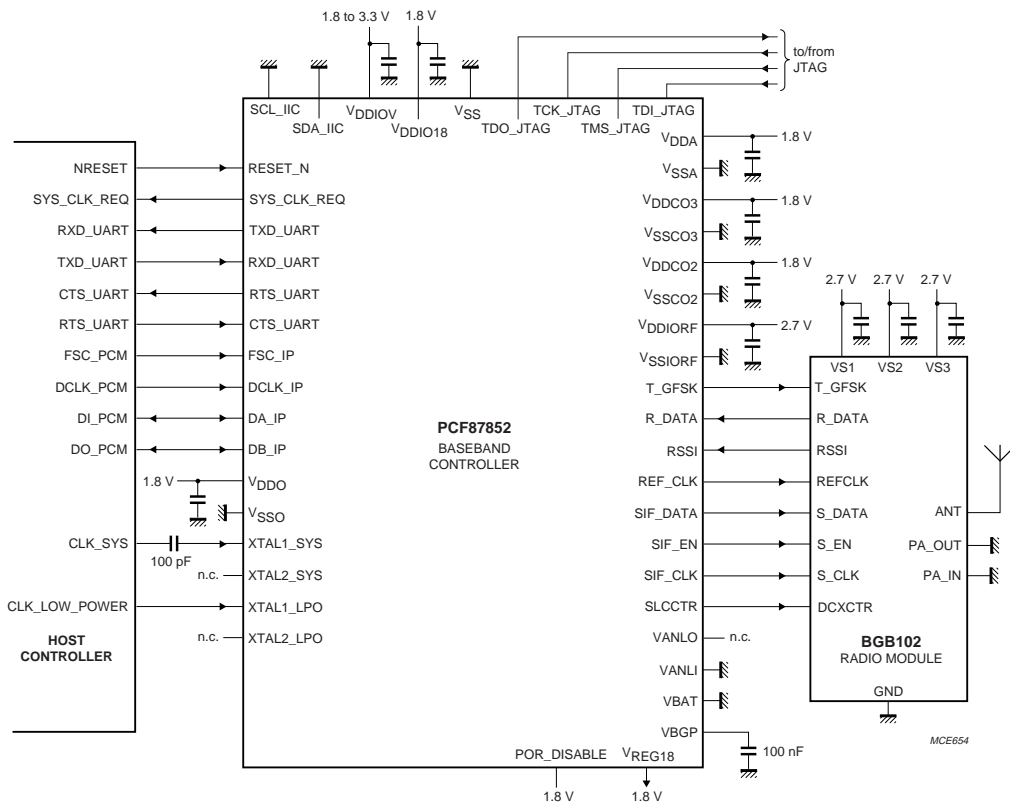

Fig 2. Application example of hosted Bluetooth system with PCF87852 and BGB102 (or BGB101) RF module.

8. Limiting values

Table 4: Limiting values

In accordance with the Absolute Maximum Rating System (IEC 60134).

Symbol	Parameter	Conditions	Min	Max	Unit
V_{DDC}	core supply voltage		-0.5	+2.5	V
V_{DDIORF}	RF interface supply voltage		-0.5	+4.6	V
V_{DDIO18}	1.8 V I/O supply voltage		-0.5	+2.5	V
V_{DDIOV}	variable I/O supply voltage		-0.5	+4.6	V
V_{DDA}	analog supply voltage		-0.5	+2.5	V
V_{DDO}	oscillator supply voltage		-0.5	+2.5	V
V_I	input voltage on any pin	with respect to ground (V_{SS})	[1] -0.5	$V_{DDX} + 0.5$	V
I_I	input DC current through any pin		-	100	mA
P_{tot}	total power dissipation		-	200	mW
T_{amb}	ambient temperature		-40	+85	°C
T_{stg}	storage temperature		-40	+125	°C

[1] V_{DDX} represents the supply voltage of the functional block associated with the pin.

9. Revision history

Table 5: Revision history

Rev	Date	CPCN	Description
01	20040423	-	Preliminary data (9397 750 12161)

10. Data sheet status

Level	Data sheet status ^[1]	Product status ^{[2][3]}	Definition
I	Objective data	Development	This data sheet contains data from the objective specification for product development. Philips Semiconductors reserves the right to change the specification in any manner without notice.
II	Preliminary data	Qualification	This data sheet contains data from the preliminary specification. Supplementary data will be published at a later date. Philips Semiconductors reserves the right to change the specification without notice, in order to improve the design and supply the best possible product.
III	Product data	Production	This data sheet contains data from the product specification. Philips Semiconductors reserves the right to make changes at any time in order to improve the design, manufacturing and supply. Relevant changes will be communicated via a Customer Product/Process Change Notification (CPCN).

[1] Please consult the most recently issued data sheet before initiating or completing a design.

[2] The product status of the device(s) described in this data sheet may have changed since this data sheet was published. The latest information is available on the Internet at URL <http://www.semiconductors.philips.com>.

[3] For data sheets describing multiple type numbers, the highest-level product status determines the data sheet status.

11. Definitions

Short-form specification — The data in a short-form specification is extracted from a full data sheet with the same type number and title. For detailed information see the relevant data sheet or data handbook.

Limiting values definition — Limiting values given are in accordance with the Absolute Maximum Rating System (IEC 60134). Stress above one or more of the limiting values may cause permanent damage to the device. These are stress ratings only and operation of the device at these or at any other conditions above those given in the Characteristics sections of the specification is not implied. Exposure to limiting values for extended periods may affect device reliability.

Application information — Applications that are described herein for any of these products are for illustrative purposes only. Philips Semiconductors make no representation or warranty that such applications will be suitable for the specified use without further testing or modification.

12. Disclaimers

Life support — These products are not designed for use in life support appliances, devices, or systems where malfunction of these products can reasonably be expected to result in personal injury. Philips Semiconductors customers using or selling these products for use in such applications do so at their own risk and agree to fully indemnify Philips Semiconductors for any damages resulting from such application.

Right to make changes — Philips Semiconductors reserves the right to make changes in the products - including circuits, standard cells, and/or software - described or contained herein in order to improve design and/or

performance. When the product is in full production (status 'Production'), relevant changes will be communicated via a Customer Product/Process Change Notification (CPCN). Philips Semiconductors assumes no responsibility or liability for the use of any of these products, conveys no licence or title under any patent, copyright, or mask work right to these products, and makes no representations or warranties that these products are free from patent, copyright, or mask work right infringement, unless otherwise specified.

13. Licenses

Purchase of Philips I²C components



Purchase of Philips I²C components conveys a license under the Philips' I²C patent to use the components in the I²C system provided the system conforms to the I²C specification defined by Philips. This specification can be ordered using the code 9398 393 40011.

14. Trademarks

Bluetooth — is a trademark of the Bluetooth SIG, Inc, USA and used by Philips Semiconductors under license.

ARM7TDMI — is a trademark of ARM Ltd.

I²C-bus — is a trademark of Koninklijke Philips Electronics N.V.

IOM — is a registered trademark of Siemens AG and Infinition Technologies AG.

Contact information

For additional information, please visit <http://www.semiconductors.philips.com>.
For sales office addresses, send e-mail to: sales.addresses@www.semiconductors.philips.com.

Fax: +31 40 27 24825

Contents

1	General description	1
2	Features	1
2.1	Baseband hardware	1
2.2	Firmware	2
2.3	General	2
3	Applications	2
4	Quick reference data	3
5	Ordering information	5
6	Block diagram	6
7	Functional description	7
8	Limiting values	9
9	Revision history	10
10	Data sheet status	11
11	Definitions	11
12	Disclaimers	11
13	Licenses	11
14	Trademarks	11

© Koninklijke Philips Electronics N.V. 2004.
Printed in The Netherlands

All rights are reserved. Reproduction in whole or in part is prohibited without the prior written consent of the copyright owner.

The information presented in this document does not form part of any quotation or contract, is believed to be accurate and reliable and may be changed without notice. No liability will be accepted by the publisher for any consequence of its use. Publication thereof does not convey nor imply any license under patent- or other industrial or intellectual property rights.

Date of release: 23 April 2004

Document order number: 9397 750 12161



PHILIPS

Let's make things better.