

DATA SHEET

PCA84C922; PCA84C923 Microcontrollers for universal infrared remote transmitter applications

Product specification
Supersedes data of 1995 Jun 30
File under Integrated Circuits, IC14

1997 Oct 22

**Microcontrollers for universal infrared
remote transmitter applications****PCA84C922; PCA84C923****CONTENTS**

1	FEATURES
2	GENERAL DESCRIPTION
3	ORDERING INFORMATION
4	BLOCK DIAGRAMS
5	PINNING INFORMATION
5.1	Pinning
5.2	Pin description
6	GENERAL OPERATION DESCRIPTION
6.1	System selection
6.2	Key scanning
6.3	Accessing command code
7	HARDWARE MODULATOR
7.1	ON-time Register
7.2	OFF-time Register
7.3	Pulse Timer
7.4	Pulse Counter
7.5	Hardware Modulator Control Register (HMCTL)
7.6	Operation of the Hardware Modulator
8	CODING TABLE
8.1	Accessing the Coding Table
9	WATCHDOG TIMER (WDT)
10	PORT OPTIONS
11	INTERRUPTS
11.1	External keypad wake-up and $T0/\overline{INT}$ pin interrupt
11.2	Hardware Modulator interrupt
11.3	Internal Timer/counter (T1) interrupt
12	DERIVATIVE REGISTERS
13	EMULATION
14	LIMITING VALUES
15	DC CHARACTERISTICS
16	AC CHARACTERISTICS
17	PACKAGE OUTLINES
18	SOLDERING
18.1	Introduction
18.2	SDIP
18.3	SO and VSO
19	DEFINITIONS
20	LIFE SUPPORT APPLICATIONS

Microcontrollers for universal infrared remote transmitter applications

PCA84C922; PCA84C923

1 FEATURES

- 84CXXX CPU
- ROM, RAM, I/O and keypad configurations are device dependent; see Table 1
- Two test inputs: T0 and T1
- 3 single-level vectored interrupt sources:
 - external ($T0/\overline{INT}$ and Port 1, for keypad press Wake-up function)
 - Timer/counter (TI)
 - Hardware Modulator interrupt
- 8-bit programmable timer/counter with 5-bit prescaler
- Power saving Idle and Stop modes
- Low power operation: 2 V
- Hardware Modulator
- Watchdog timer
- On-chip oscillator: 1 to 6 MHz
- Single supply voltage: 2.0 to 5.5 V
- Operating temperature: -20 to +70 °C
- Available packages: SO24, SO28, VSO56 and SDIP24.

2 GENERAL DESCRIPTION

The PCA84C922A, PCA84C922C, PCA84C923A, PCA84C923C and PCA84C923D are members of the PCF84CXXXA CMOS family of microcontrollers and have been designed for use in universal infrared remote commander applications. The term PCA84C92X is used throughout this data sheet to refer to all devices in the range, differences between devices are shown in Table 1 and also highlighted in the text. In addition to the common functions of the PCF84CXXXA family of microcontrollers the PCA84C92X also provides:

- a Hardware Modulator that generates programmable pulse trains for driving an infrared LED
- an on-chip Coding Table specifically for the storage of code data
- a modified interrupt architecture that will wake-up the CPU from the Idle or Stop modes when any key is pressed
- a Watchdog Timer to prevent CPU lock-up.

The PCA84C923D has been designed as the emulation chip for both the PCA84C92X and the PCA84CX22 range of microcontrollers (both ranges being pin compatible).

Table 1 The PCA84C92X range of microcontrollers

FUNCTION	PCA84C923D	PCA84C923C	PCA84C923A	PCA84C922C	PCA84C922A
System ROM	8 kbytes	8 kbytes	8 kbytes	8 kbytes	8 kbytes
System RAM	256 bytes	256 bytes	256 bytes	128 bytes	128 bytes
Coding Table ROM	16 kbytes	16 kbytes	16 kbytes	8 kbytes	8 kbytes
Coding Table extension	up to 64 kbytes	no	no	no	no
Maximum number of keys	189	117	81	117	81
I/O	36	20	16	20	16
Emulation device	PCA84C923D	PCA84C923D	PCA84C923D	PCA84C923D	PCA84C923D
Package	VSO56	SO28	SO24 and SDIP24	SO28	SO24 and SDIP24

3 ORDERING INFORMATION

TYPE NUMBER	PACKAGE		
	NAME	DESCRIPTION	VERSION
PCA84C922AP	SDIP24	plastic shrink dual in-line package; 24 leads (400 mil)	SOT234-1
PCA84C922AT	SO24	plastic small outline package; 24 leads; body width 7.5 mm	SOT137-1
PCA84C922CT	SO28	plastic small outline package; 28 leads; body width 7.5 mm	SOT136-1
PCA84C923AP	SDIP24	plastic shrink dual in-line package; 24 leads (400 mil)	SOT234-1
PCA84C923AT	SO24	plastic small outline package; 24 leads; body width 7.5 mm	SOT137-1
PCA84C923CT	SO28	plastic small outline package; 28 leads; body width 7.5 mm	SOT136-1
PCA84C923DT	VSO56	plastic very small outline package; 56 leads	SOT190-1

Microcontrollers for universal infrared remote transmitter applications

PCA84C922; PCA84C923

4 BLOCK DIAGRAMS

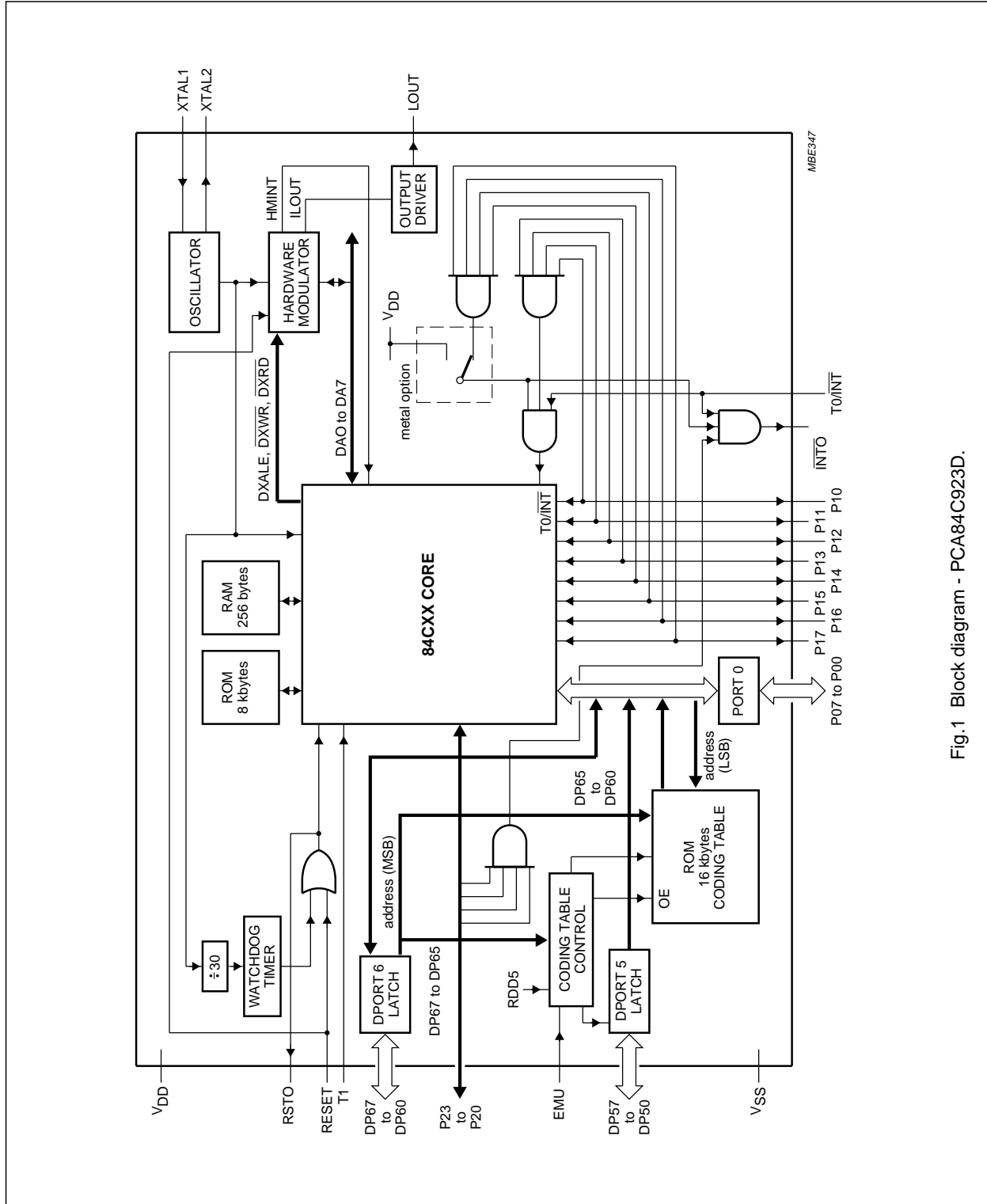

Fig.1 Block diagram - PCA84C923D.

Microcontrollers for universal infrared remote transmitter applications

PCA84C922; PCA84C923

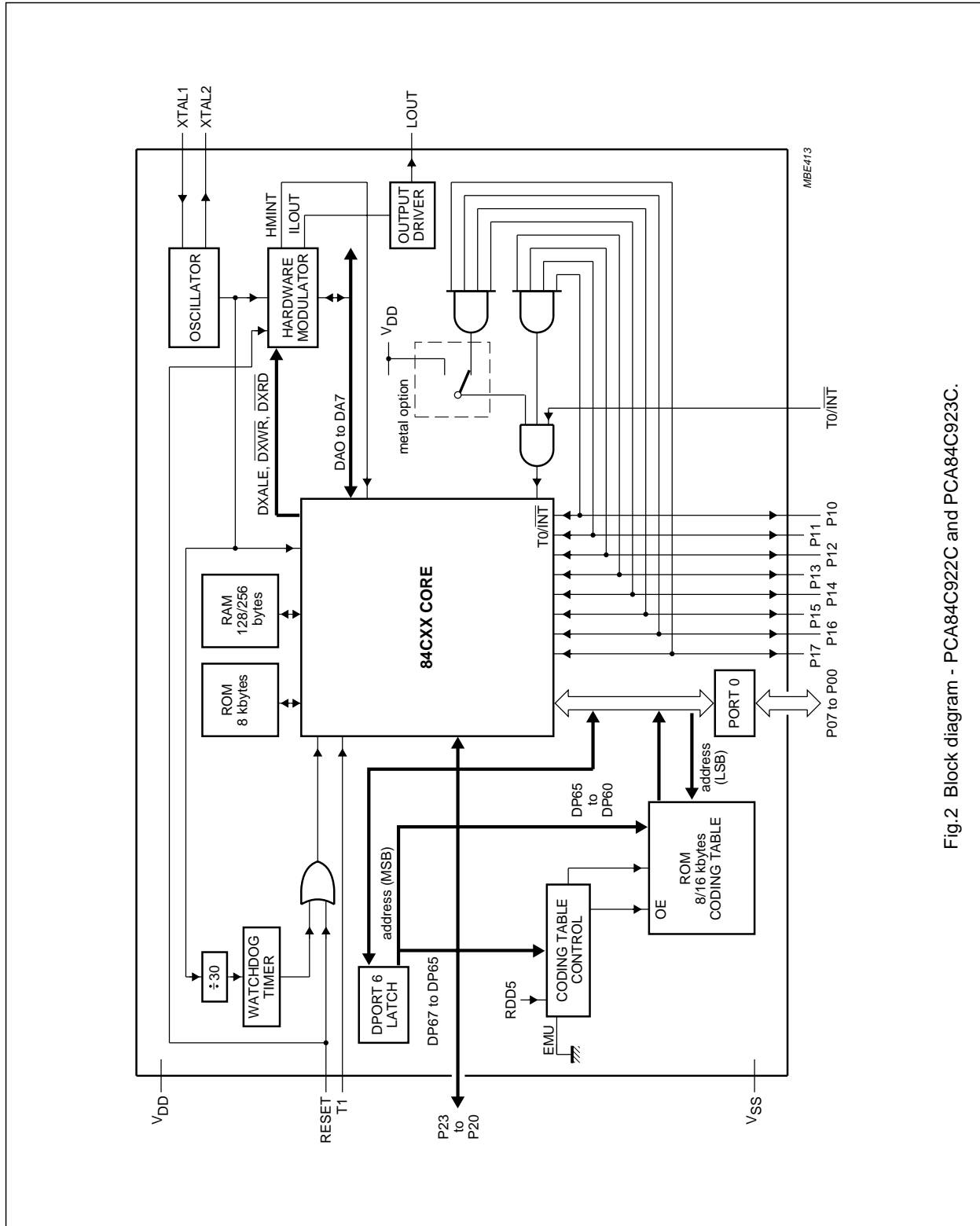

Fig.2 Block diagram - PCA84C922C and PCA84C923C.

Microcontrollers for universal infrared remote transmitter applications

PCA84C922; PCA84C923

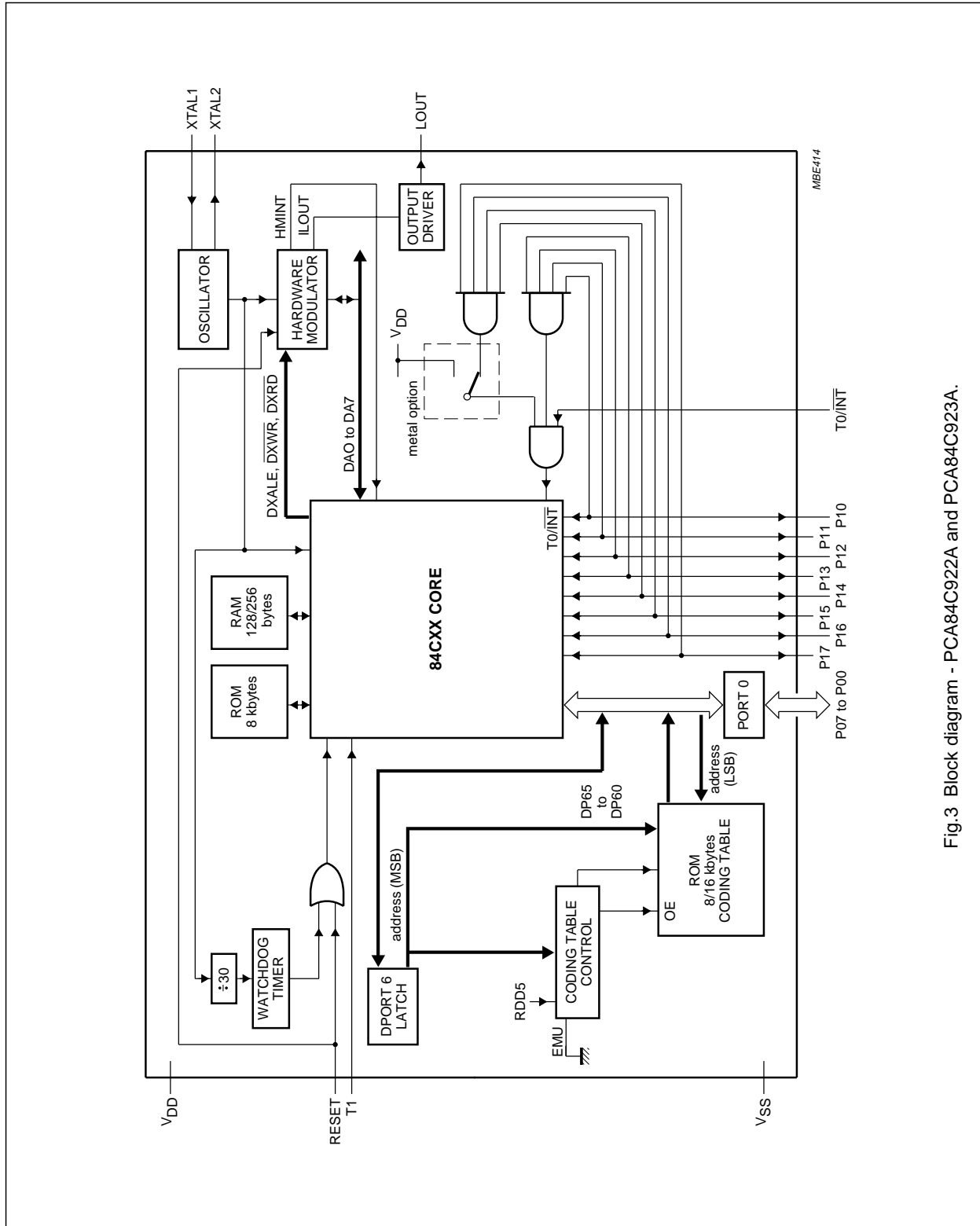

Fig.3 Block diagram - PCA84C922A and PCA84C923A.

Microcontrollers for universal infrared remote transmitter applications

PCA84C922; PCA84C923

5 PINNING INFORMATION

5.1 Pinning

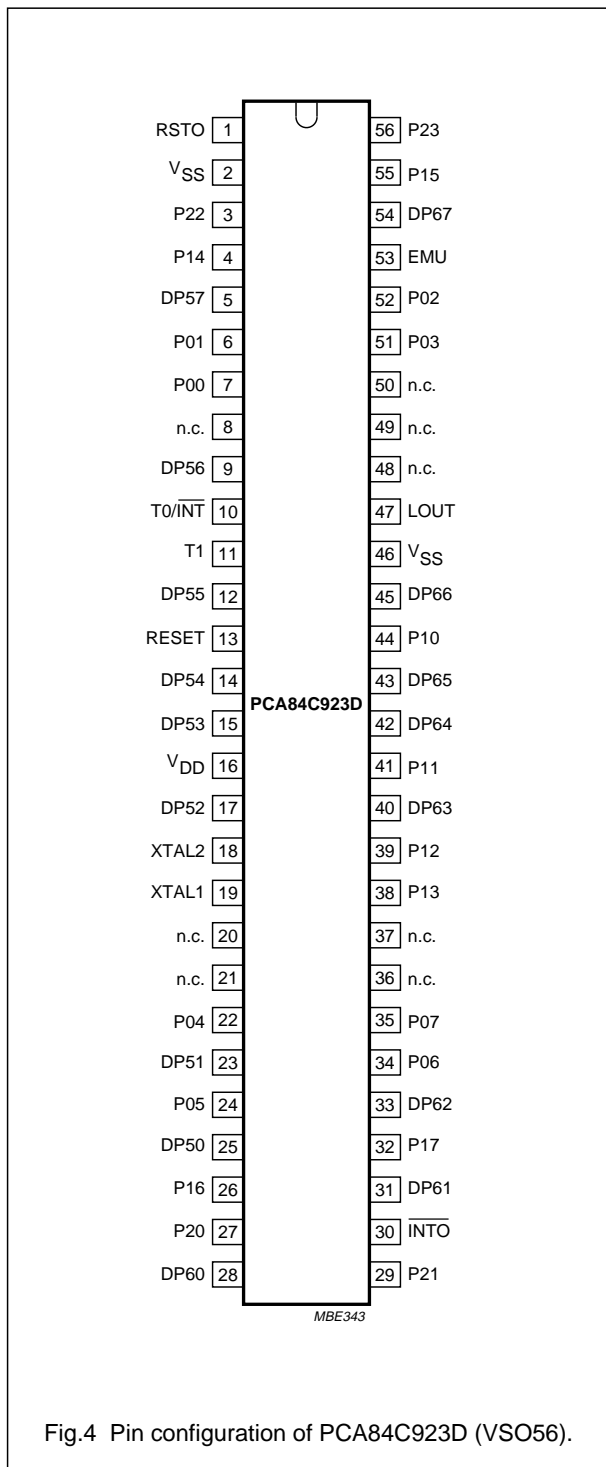

Fig.4 Pin configuration of PCA84C923D (VSO56).

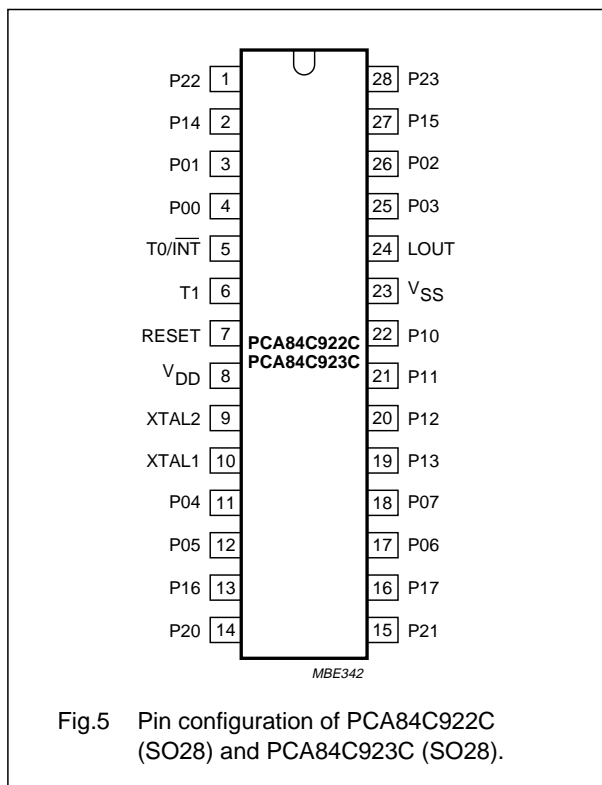

Fig.5 Pin configuration of PCA84C922C (SO28) and PCA84C923C (SO28).

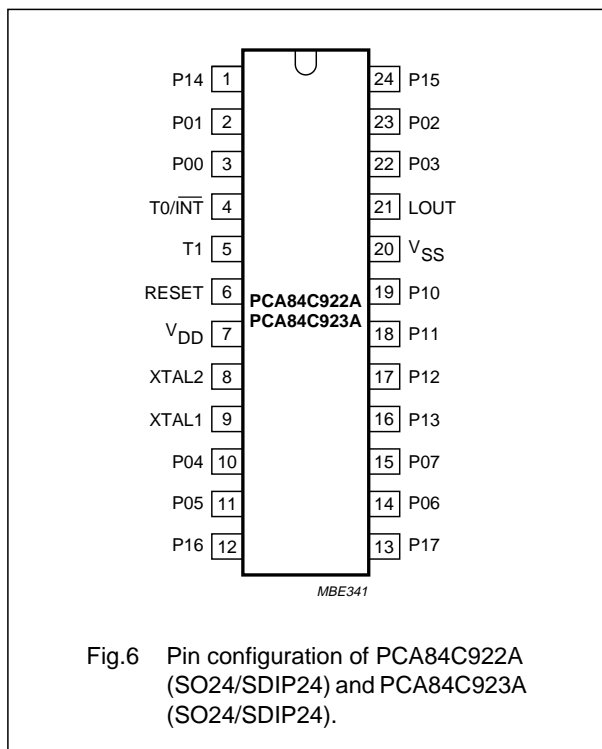

Fig.6 Pin configuration of PCA84C922A (SO24/SDIP24) and PCA84C923A (SO24/SDIP24).

Microcontrollers for universal infrared remote transmitter applications

PCA84C922; PCA84C923

5.2 Pin description

Table 2 PCA84C923D (VS056)

SYMBOL	PIN	DESCRIPTION
P00 to P07	7, 6, 52, 51, 22, 24, 34 and 35	Standard I/O Port lines, generally used for keypad scanning or for LSB address lines of coding table.
P10	44	Port line 10 or emulation \overline{DXWR} signal input.
P11	41	Port line 11 or emulation \overline{DXRD} signal input.
P12	39	Port line 12 or emulation \overline{DXALE} signal input.
P13	38	Port line 13 or emulation \overline{EXDI} signal input.
P14 to P17	4, 55, 26 and 32	Standard I/O port lines, generally used for keypad sensing, the wake-up function can be removed by mask option.
P20 to P23	27, 29, 3 and 56	Standard I/O port lines with 10 mA sink capability.
DP50 to DP57	25, 23, 17, 15, 14, 12, 9 and 5	Standard I/O port lines, generally used for the data bus of Coding Table.
DP60 to DP67	28, 31, 33, 40, 42, 43, 45 and 54	Standard I/O Port lines, generally used for keypad scanning or for MSB address lines of Coding Table.
RSTO	1	Used for emulation purposes only. This output is the result of the OR operation carried out internally on the RESET input and the Watchdog Timer reset and is connected to the RESET pin of the 84C00.
T0/ \overline{INT}	10	Test pin T0 or external interrupt input.
T1	11	Test pin T1 or timer/counter input (T1).
RESET	13	Active HIGH reset pin; normally connected to V_{SS} as Power-on-reset serves the same function.
XTAL2	18	Crystal or ceramic resonator or LC oscillator connections.
XTAL1	19	
\overline{INTO}	30	Used for emulation purposes only and is connected to the T0/ \overline{INT} pin of the 84C00.
LOUT	47	Pulse train output pin, capable of sinking 30 mA.
EMU	53	Emulation mode control pin; for normal operation this pin is connected to V_{SS} .
V_{DD}	16	Power supply.
V_{SS}	2 and 46	Ground.

Microcontrollers for universal infrared remote transmitter applications

PCA84C922; PCA84C923

Table 3 PCA84C922C (SO28) and PCA84C923C (SO28)

SYMBOL	PIN	DESCRIPTION
P00 to P07	4, 3, 26, 25, 11, 12, 17, 18	Standard I/O port lines, generally used for keypad scanning or for LSB address byte of code data.
P10 to P17	22, 21, 20, 19, 2, 27, 13, 16	Standard I/O port lines, generally used for keypad sensing, the wake-up function of P14 to P17 can be removed by mask option.
P20 to P23	14, 15, 1, 28	Standard I/O port lines with 10 mA sink capability.
T0/ $\overline{\text{INT}}$	5	Test pin T0 or external interrupt input.
T1	6	Test pin T1 or timer/counter input (T1).
RESET	7	Active HIGH reset pin; normally connected to V_{SS} as Power-on-reset serves the same function.
XTAL2	9	Crystal or ceramic resonator or LC oscillator connections.
XTAL1	10	
LOUT	24	Pulse train output pin, capable of sinking 30 mA.
V_{DD}	8	Power supply.
V_{SS}	23	Ground.

Table 4 PCA84C922A (SO24/SDIP24) and PCA84C923A (SO24/SDIP24)

SYMBOL	PIN	DESCRIPTION
P00 to P07	3, 2, 23, 22, 10, 11, 14, 15	Standard I/O port lines, generally used for keypad scanning or for LSB address byte of code data.
P10 to P17	19, 18, 17, 16, 1, 24, 12, 13	Standard I/O port lines, generally used for keypad sensing, the wake-up function of P14 to P17 can be removed by mask option.
T0/ $\overline{\text{INT}}$	4	Test pin T0 or external interrupt input.
T1	5	Test pin T1 or timer/counter input (T1).
RESET	6	Active HIGH reset pin; normally connected to V_{SS} as Power-on-reset serves the same function.
XTAL2	8	Crystal or ceramic resonator or LC oscillator connections.
XTAL1	9	
LOUT	21	Pulse train output pin, capable of sinking 30 mA.
V_{DD}	7	Power supply.
V_{SS}	20	Ground.

Microcontrollers for universal infrared remote transmitter applications

PCA84C922; PCA84C923

6 GENERAL OPERATION DESCRIPTION

The main application for the PCA84C92X is as a universal infrared remote control commander and in this role the PCA84C92X offers the complete solution in one chip.

The PCA84C92X can be programmed to generate code data that conforms to any protocol (Philips, NEC, RCA, Thomson and Siemens etc.) and is suitable for use in the remote control of TVs, VCRs, audio equipment, air-conditioning systems and in many other applications.

The ability of the PCA84C923D to access external memory and therefore support more protocols, makes it an extremely versatile device.

6.1 System selection

Different systems (TV or VCR etc.) can be controlled using one universal infrared remote control commander; switches can be used to select a specific system. However, the PCA84C92X provides pin T1 for system selection purposes and software is used to detect the specific system. Port lines P14 to P17 can also be used for system selection if their wake-up functions have not been selected as a mask option.

When no key is pressed the scan lines (Port 0) can be programmed HIGH and the sense lines (Port 1) programmed LOW. If a diode is connected between a sense line and scan line then the scan line will be pulled LOW and this can be detected by a read operation to Port 0.

6.2 Key scanning

Port lines P10 to P17 and $T0/\overline{INT}$ have been designed to be used as key sense lines. However, if the wake-up option is not selected for ports P14 to P17 then these can be used as general I/O lines.

Port lines P00 to P07, P20 to P23 and DP60 to DP67 can be used as key scan lines or general I/O ports. Derivative Port 6 also provides the High byte address for the Coding Table, even when used as scan lines.

After a Power-on-reset, the scan lines are set LOW and the sense lines HIGH. If the system has entered the Stop mode (by software) then when any key is depressed an external interrupt will be generated and the system will be woken-up.

If the external interrupt was enabled (by using the 'EN I' instruction) before the Stop mode was entered, then when the CPU is woken-up, the instruction that follows the STOP instruction will be executed before diverting to the interrupt routine at vector address 03H. However, if the interrupt was not enabled before the Stop mode was entered, then when the CPU is woken-up the instruction that follows the STOP instruction will be executed.

6.3 Accessing command code

When any key is depressed its function and operation protocol are determined, then the command code is read. If the command code is stored in system ROM it can be accessed using the 'MOVP A,@A' instruction. If the command code resides in Coding Table ROM it can be accessed by writing the address to DP60 to DP67 (High byte) and P00 to P07 (Low byte) and then reading the data from DP50 to DP57.

In Normal mode, if the Coding Table address is within the 0000 to 1FFFH range for PCA84C922 devices, or within the 0000 to 3FFFH range for PCA84C923 devices, then the internal Coding Table will be accessed when Derivative Port 5 (address 05H) is read.

In the Normal mode only the PCA84C923D has the ability to access external memory. If the Coding Table address is greater than 3FFFH then the external memory will be accessed when Derivative Port 5 (terminal) is read.

When the PCA84C923D is used in the Emulation mode, when Derivative Port 5 is read, data will always be read from DP50 to DP57 terminals. Therefore, the internal Coding Table ROM can be emulated when the PCA84C923D and the bond-out chip PCF84C00 are used.

Microcontrollers for universal infrared remote transmitter applications

PCA84C922; PCA84C923

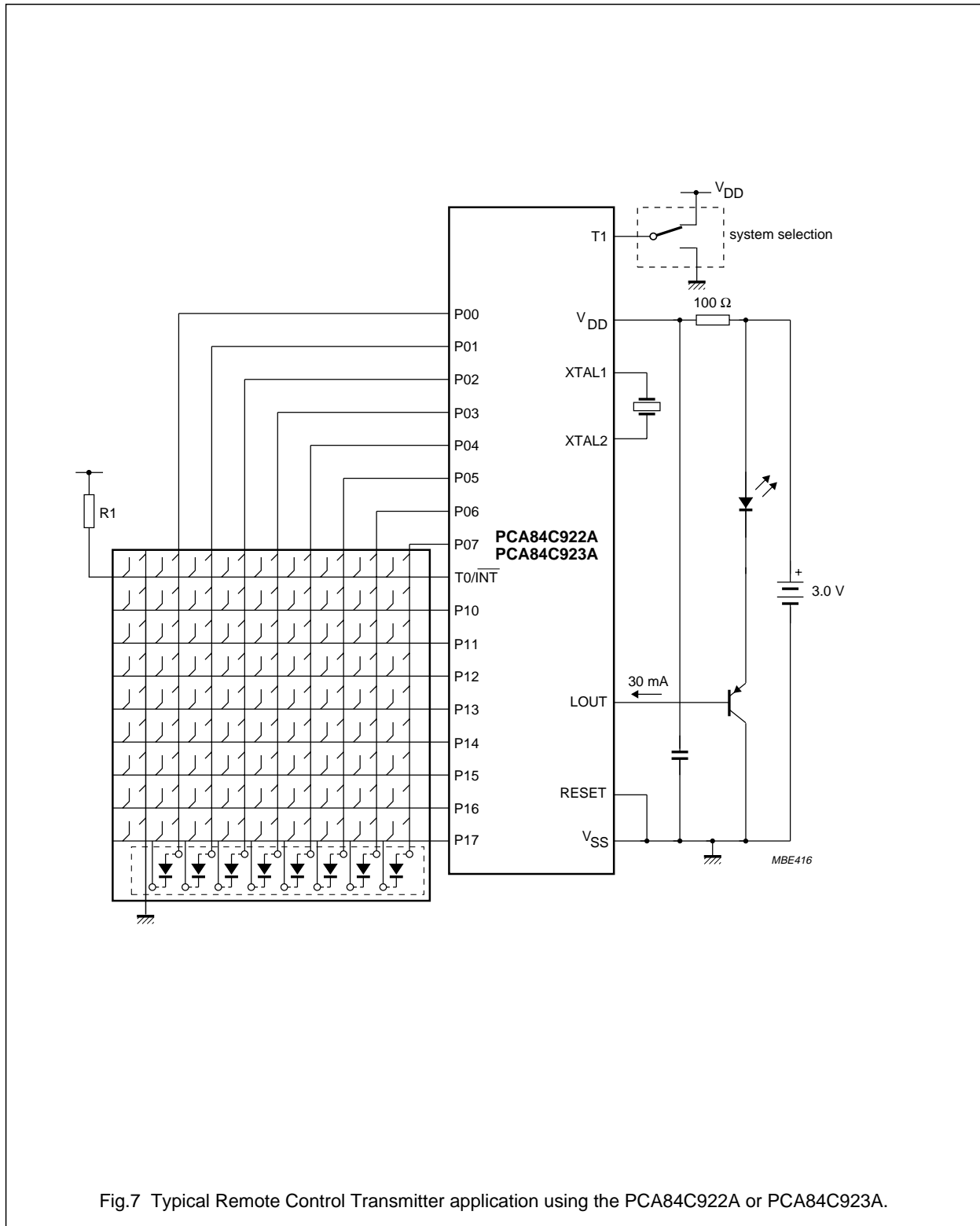

Fig.7 Typical Remote Control Transmitter application using the PCA84C922A or PCA84C923A.

Microcontrollers for universal infrared remote transmitter applications

PCA84C922; PCA84C923

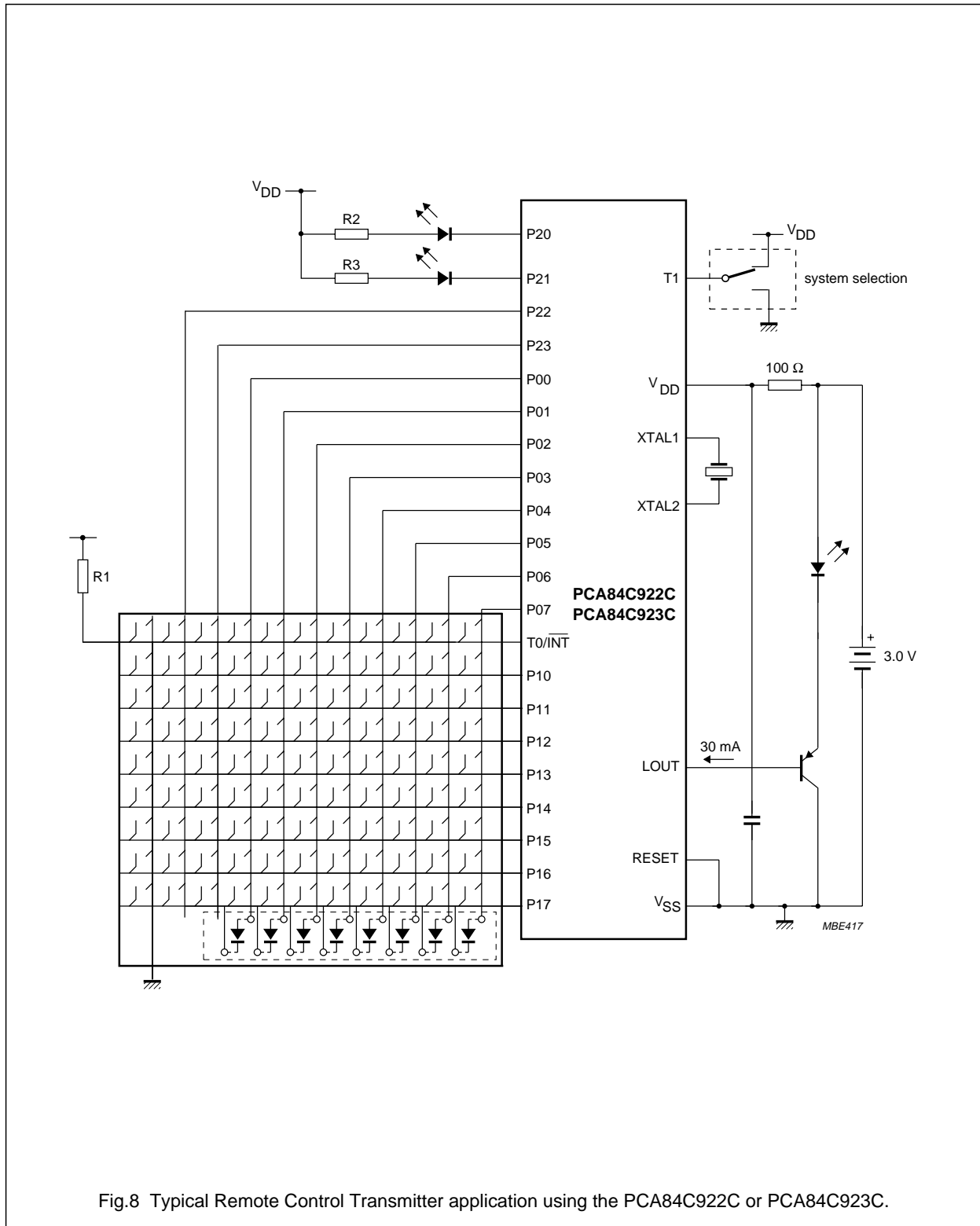

Fig.8 Typical Remote Control Transmitter application using the PCA84C922C or PCA84C923C.

Microcontrollers for universal infrared remote transmitter applications

PCA84C922; PCA84C923

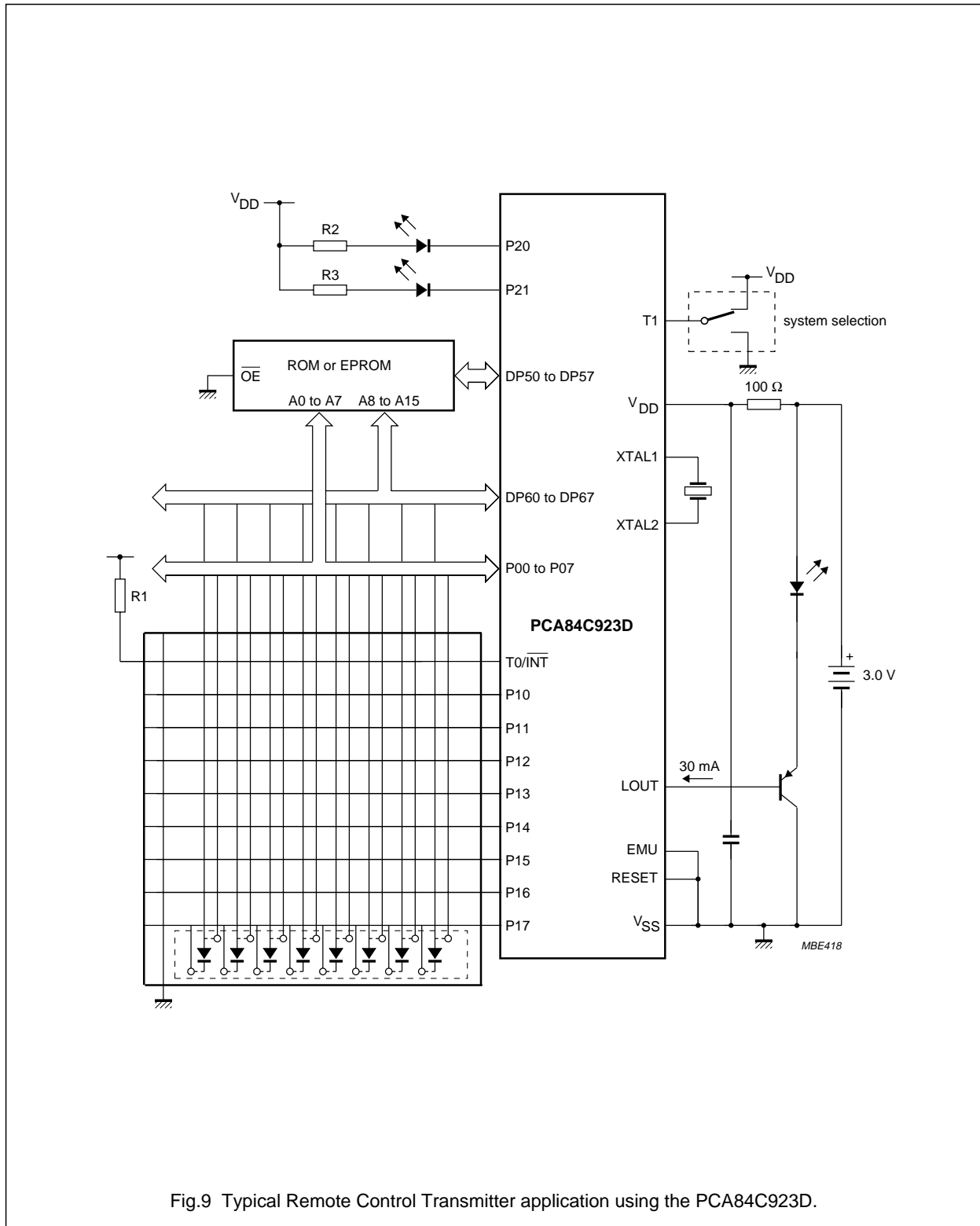

Fig.9 Typical Remote Control Transmitter application using the PCA84C923D.

Microcontrollers for universal infrared remote transmitter applications

PCA84C922; PCA84C923

7 HARDWARE MODULATOR

The Hardware Modulator used in the PCA84C92X is the same as the Hardware modulator used in the PCA84CX22 range of microcontrollers.

The function of the Hardware Modulator is to generate a coded pulse train which is subsequently converted into an infrared signal by an IR-LED. It is this coded IR signal that controls the remote equipment. The number of pulses in the pulse train, the time between pulse train bursts and the duty cycle of a pulse are all programmable. A typical pulse train is shown in Fig.10.

The block diagram of the Hardware Modulator is shown in Fig.14 and comprises:

- An 8-bit ON-time Register
- An 8-bit OFF-time Register
- An 8-bit Control Register
- A Pulse Timer
- A 10-bit Pulse Counter
- Control logic.

These are described in detail in Sections 7.1 to 7.5.

7.1 ON-time Register

The duty cycle of the pulse is determined by the contents of the ON-time and OFF-time Registers. The ON-time Register controls the active or ON period of the pulse; the OFF-time Register controls the inactive or OFF period of the cycle.

The 8-bit ON-time Register resides at address 00H and is loaded by software. The decimal value of its contents plus 2, determines the number of oscillator cycles that the LOUT pin is active. The active period of LOUT can be calculated as follows:

$$t_{\text{ON}} = \frac{(\text{decimal value held in ON-time Register} + 2)}{f_{\text{osc}}}$$

7.2 OFF-time Register

This 8-bit register resides at address 01H and is loaded by software. The decimal value of its contents plus 2, determines the number of oscillator cycles that the LOUT pin is inactive.

The inactive period of LOUT can be calculated as follows:

$$t_{\text{OFF}} = \frac{(\text{decimal value held in OFF-time Register} + 2)}{f_{\text{osc}}}$$

7.3 Pulse Timer

The contents of the ON-time and OFF-time Registers are loaded alternately into the Pulse Timer. When loaded the Pulse Timer contents are decremented by '1' every oscillator cycle and upon reaching zero the Pulse Timer will be reloaded with the contents of the other register.

7.4 Pulse Counter

The 10-bit Pulse Counter actually consists of two registers: the 2-bit Pulse Counter High Register that resides at address 04H, and the 8-bit Pulse Counter Low Register that resides at address 02H.

The Pulse Counter is loaded by software; its contents determine the number of pulses in a specific pulse train. Loading with zero is not allowed.

7.5 Hardware Modulator Control Register (HMCTL)

The characteristics of the pulse train are initially determined by the contents of the ON-time Register, the OFF-time Register and the Pulse Counter; however, the HMCTL Register allows these characteristics to be modified. The Watchdog Timer and derivative interrupt flag are reset via this register.

Microcontrollers for universal infrared remote transmitter applications

PCA84C922; PCA84C923

Table 5 Hardware Control Register (address 03H)

7	6	5	4	3	2	1	0
–	–	–	WRES	Rint	PWM	LgP	HF

Table 6 Description of the HMCTL bits

BIT	SYMBOL	DESCRIPTION
7 to 5	–	These three bits are reserved.
4	WRES	Reset Watchdog Timer. This is not a flip-flop in the register and can only be written to. If a logic 1 is written to this bit the Watchdog Timer is reset.
3	Rint	Reset interrupt. When Rint = 1; the interrupt flag that was set by the derivative logic is cleared. The Hardware Modulator can only be restarted after the interrupt flag is cleared; this avoids a second interrupt being generated before the first one has been serviced.
2	PWM	Pulse Width Modulation. When PWM = 1 and LgP = 0; the Pulse Counter Register is ignored and a continuous pulse train is generated, this is shown in Fig.13.
1	LgP	Long Pulse. When LgP = 1; the contents of the OFF-time Register are ignored. A single pulse is generated; its pulse width being determined as shown below. $\text{Pulse width} = (\text{Contents of ON-time Register} + 2) \times (\text{number of pulses}) \times \frac{1}{f_{\text{osc}}}$ If HF = 1; this pulse is modulated with a frequency $\frac{1}{4}f_{\text{osc}}$, this is shown in Fig.12.
0	HF	High Frequency. When HF = 1; the ON-time part of the generated pulse is modulated with a frequency $\frac{1}{4}f_{\text{osc}}$, this is shown as CASE 2 in Figs 11 and 12.

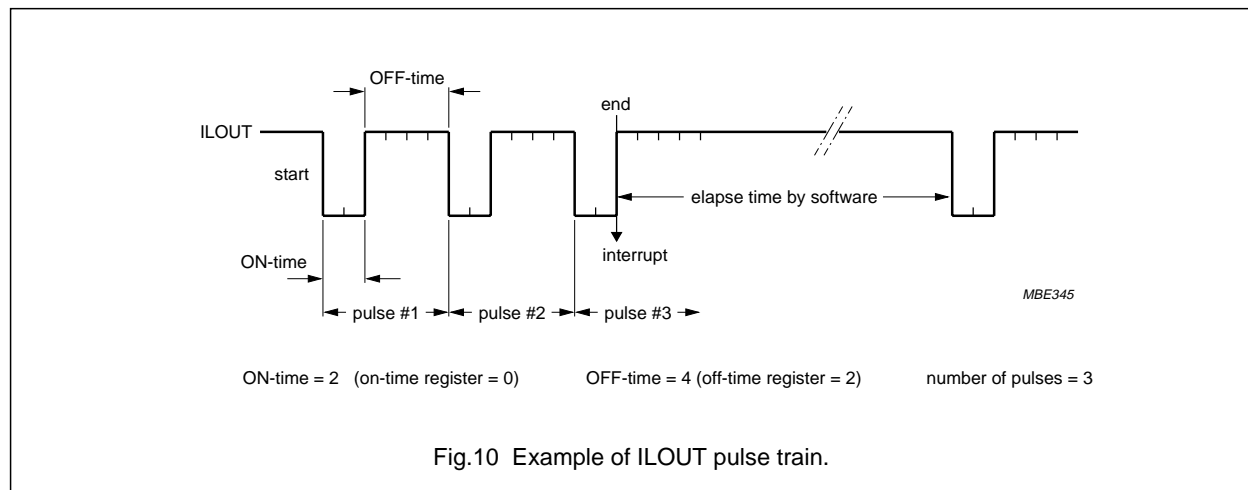

Microcontrollers for universal infrared remote transmitter applications

PCA84C922; PCA84C923

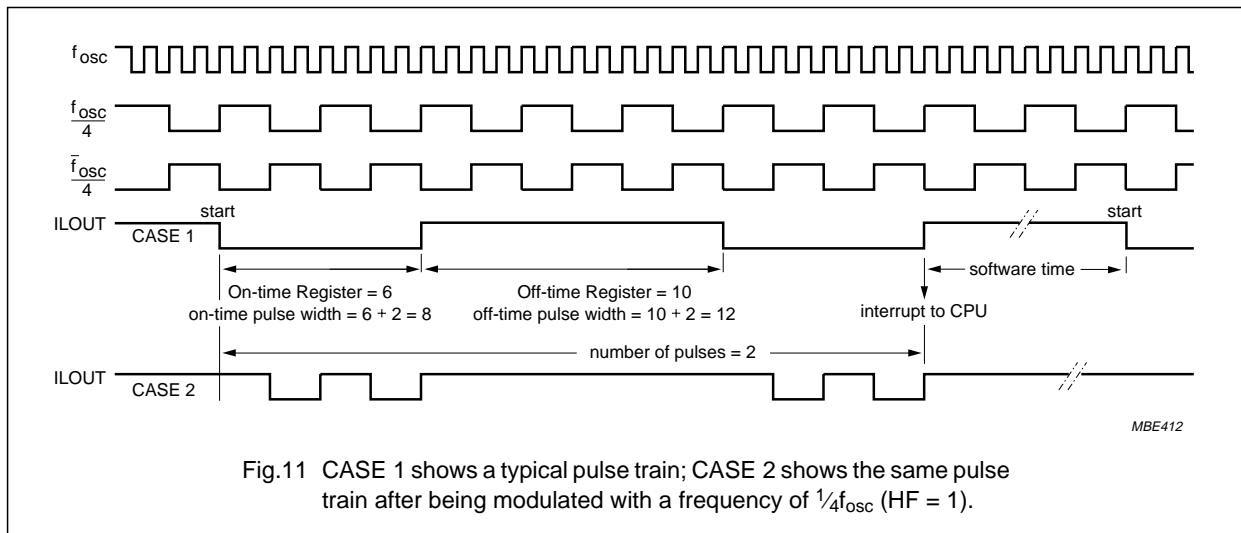

Fig.11 CASE 1 shows a typical pulse train; CASE 2 shows the same pulse train after being modulated with a frequency of $\frac{1}{4}f_{osc}$ (HF = 1).

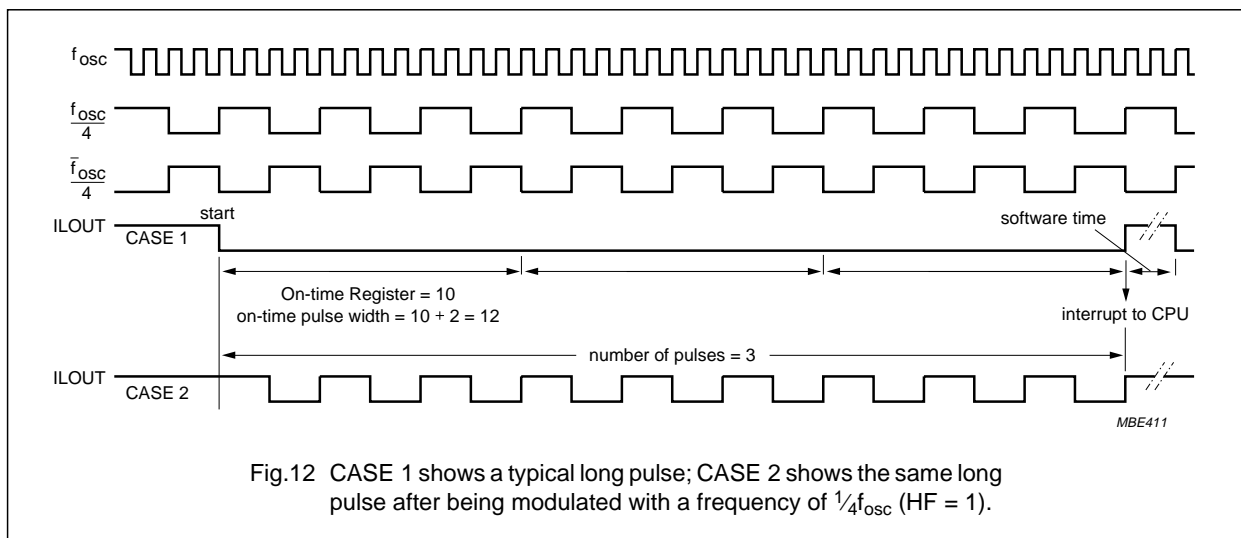

Fig.12 CASE 1 shows a typical long pulse; CASE 2 shows the same long pulse after being modulated with a frequency of $\frac{1}{4}f_{osc}$ (HF = 1).

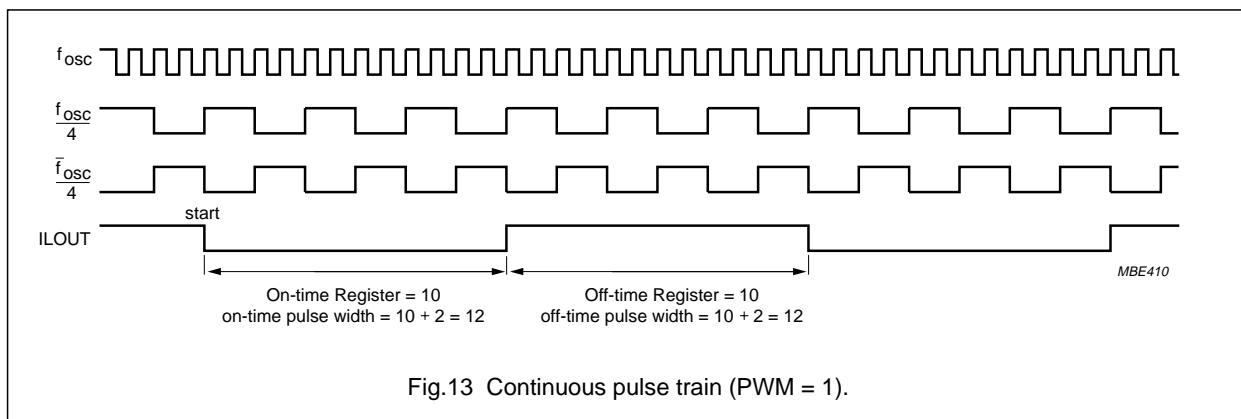

Fig.13 Continuous pulse train (PWM = 1).

Microcontrollers for universal infrared remote transmitter applications

PCA84C922; PCA84C923

7.6 Operation of the Hardware Modulator

The ON-time, OFF-time, Pulse Counter High and Pulse Counter Low registers are loaded by software.

As soon as the Pulse Counter Low Register is loaded the Hardware Modulator is started and LOUT becomes active (LOW). Simultaneously, the contents of the ON-time Register are loaded into the Pulse Timer which is then decremented by '1' every oscillator clock cycle. When the value held in the Pulse Timer becomes zero the contents of the Pulse Counter are decremented by '1' and LOUT becomes inactive (HIGH).

The contents of the OFF-time Register are now loaded into the Pulse Timer which is decremented by '1' every oscillator clock cycle. When the value held in the Pulse Timer becomes zero, LOUT becomes active (LOW). One pulse cycle has now been generated.

The process of alternately loading the contents of the ON-time Register and OFF-time Register into the Pulse Timer continues until the contents of the Pulse Counter become zero. When this occurs $\overline{\text{EXDI}}$ is asserted; an interrupt to the CPU is generated and the interrupt flag is raised stopping the operation of the Hardware Modulator. The programmed pulse train has now been generated.

The Hardware Modulator can only be restarted after the interrupt flag has been cleared. The interrupt flag is cleared by writing a logic 1 to the Rint bit in the Hardware Modulator Control Register.

The time delay between two pulse trains is determined by software.

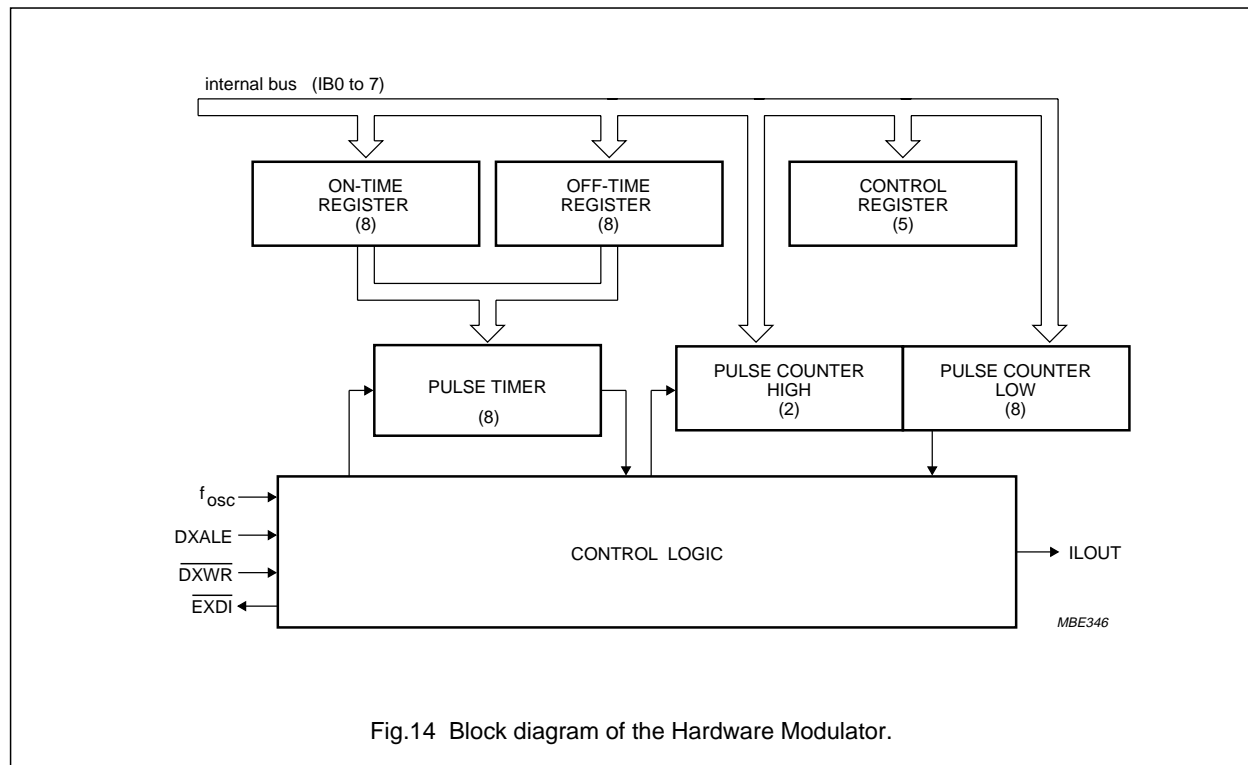

Fig.14 Block diagram of the Hardware Modulator.

Microcontrollers for universal infrared remote transmitter applications

PCA84C922; PCA84C923

8 CODING TABLE

The code data transmitted from the LOUT output when any key is depressed, is stored in a memory area known as the Coding Table. The PCA84C92X range of microcontrollers have on-chip ROM specifically for this use (system ROM may also be used). The Coding Table is addressed via Port 0 (the Low byte address) and Derivative Port 6 latch (the High byte address).

The PCA84C922 range of devices have 8 kbytes of ROM for use as a Coding Table and when accessing this internal memory, address lines DP65 to DP67 must be LOW.

The PCA84C923 range of devices have 16 kbytes of ROM for use as a Coding Table and when accessing this internal memory, address lines DP66 and DP67 must be LOW.

The Coding Table memory size for the PCA84C923D however, can be extended up to 64 kbytes by adding external memory (ROM or EPROM). The external memory data bus is connected to Derivative Port 5. Accessing the internal or external Coding Tables of the PCA84C923D is described below.

- In the Normal mode (EMU pin LOW)
 - When Derivative Port 5 terminal is read, if the address lines DP66 and DP67 are LOW, the address will be within the internal memory boundary, and the internal Coding Table will be accessed.
 - When Derivative Port 5 terminal is read, if either of the address lines DP66 or DP67 is HIGH, the address will be outside the internal memory boundary and the external memory will be accessed. The data at Derivative Port 5 terminal will then be read.

- In the Emulation mode (EMU pin HIGH)
 - When Derivative Port 5 terminal is read, external memory will always be accessed. In this situation, Derivative Port 5 latch cannot be read.

8.1 Accessing the Coding Table

The procedure for accessing the Coding Table follows:

1. Set all sense lines to a logic 1.
2. Write the High byte address to Derivative Register 08 (Derivative Port 6 latch).
3. Write the Low byte address to Port 0 (Low byte address latch of internal Coding Table).
4. Read Derivative Register 05 (Derivative Port 5 terminal); code data has now been retrieved.
5. Repeat steps 4 and 5 to read more code data.

Table 7 shows a subroutine that reads the Coding Table and then loads code data into system RAM.

Entry:

R0 contains the starting address in system RAM into which data will be loaded.

R1 contains the number of bytes in the Coding Table which are to be read.

R3 holds the Coding Table starting address (Low byte).

R4 holds the Coding Table starting address (High byte).

Exit:

$((R0)), ((R0) + 1) \rightarrow ((R0) + (R1) - 1)$ contain the code data

Table 7 Subroutine to access the Coding Table

ADDRESS	INSTRUCTION	DESCRIPTION
CODE	ORL P1,#FF	Set all sense lines to logic 1.
	MOV A,R4	Load Accumulator with the High byte of the starting address.
	MOV D8,A	Write the High byte of the starting address to Derivative Port 6 latch.
CODE1	MOV A,R3	Load Accumulator with the Low byte of the starting address.
	OUTL P0,A	Write the Low byte of the starting address to Port 0.
	MOV A,D5	Read code data from Derivative Port 5 terminal into the Accumulator.
	MOV @R0,A	Store code data in system RAM.
	DJNZ R1,CODE2	If more code data is to be read jump to CODE 2, if not go to next instruction.
	RET	Return from subroutine to main program.
CODE2	INC R0	Increment RAM address pointer.
	INC R3	Increment Low byte address of Coding Table.
	JMP CODE1	Jump to CODE 1.

Microcontrollers for universal infrared remote transmitter applications

PCA84C922; PCA84C923

9 WATCHDOG TIMER (WDT)

The PCA84C92X contains a Watchdog Timer that functions in the same manner as the Watchdog Timer used in the PCA84CX22 range of microcontrollers.

The purpose of the Watchdog Timer is to reset the microcontroller if it enters an erroneous processor state; within a reasonable period of time. Erroneous processor states can be caused by noise or RFI.

The Watchdog Timer consists of a 17-bit counter which is clocked at a frequency of $\frac{1}{30}f_{osc}$. During a Power-on-reset the contents of the counter are cleared. The counter contents are then incremented by '1' every 30 cycles of the oscillator clock. If the maximum count is exceeded, the counter overflows and the microcontroller is reset. In order to prevent a counter overflow and its resulting reset operation, the user program must clear the contents of the Watchdog Timer before its maximum count is reached.

During normal processing, the contents of the Watchdog Timer are cleared by writing a logic 1 to the WRES bit in Hardware Modulator Control Register (address 03H).

The maximum time period (t_p) which the counter may run and not cause a reset operation, is calculated as shown below.

$$t_p = \frac{1}{f_{osc}} \times 30 \times 2^{16}$$

In the Idle mode the oscillator is still running and the Watchdog Timer remains active. In the Stop mode however, the oscillator is stopped and the operation of the Watchdog Timer is halted but its contents are retained. Therefore, it may be advisable for the user to clear the contents of the Watchdog Timer before the Stop mode is entered, in order to avoid an unexpected reset operation after the device is woken-up.

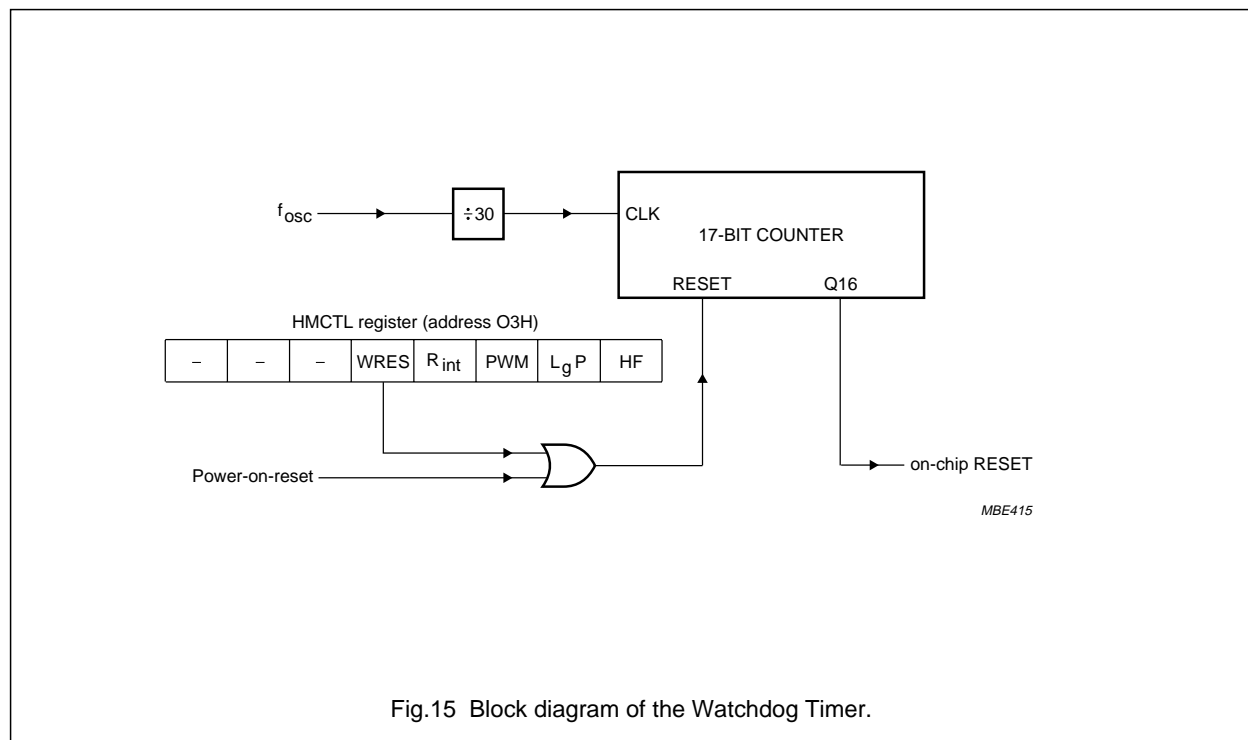

Microcontrollers for universal infrared remote transmitter applications

PCA84C922; PCA84C923

10 PORT OPTIONS

Ports can be configured using one of three mask options. The three I/O mask options are specified below.

Option 1 Standard I/O with switched pull-up current source; this is shown in Fig.16.

Option 2 I/O with open-drain output; this is shown in Fig.17.

Option 3 Push-pull output; this is shown in Fig.18.

The state of the ports and the LOUT pin after a Power-on-reset can also be selected using mask options. All mask options are given in Table 8.

Notes to Table 8

1. If diodes are used for system selection the scan lines (Port 0 and Derivative Port 6) cannot take Option 3.
2. Scan lines should have the option '1R'.
3. Sense lines should have the option '1S'.
4. Only the PCA84C923D has external Derivative Port 6 terminals and therefore this option is only valid for this device. The other members of the range have the state of their internal Derivative Port 6 latch fixed at '1S'.

Table 8 Mask options

PORT LINES/PIN	S	R	OPTION
P00 to P07			1 or 3; notes 1 and 2
P10 to P13	X		1; note 3
P14 to P17			1; note 3
P20 to P23			
DP50 to DP57	X		1
DP60 to DP67			1 or 3; notes 1, 2 and 4
LOUT	X		2 or 3

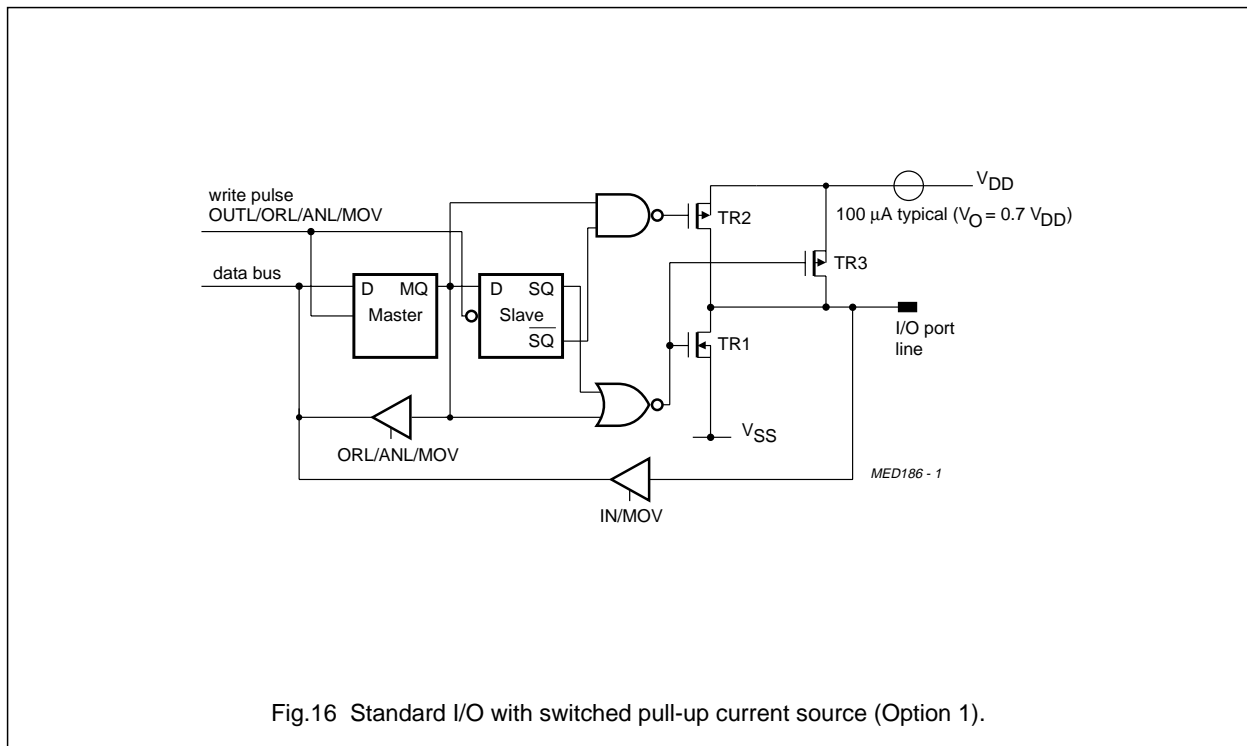

Fig.16 Standard I/O with switched pull-up current source (Option 1).

Microcontrollers for universal infrared remote transmitter applications

PCA84C922; PCA84C923

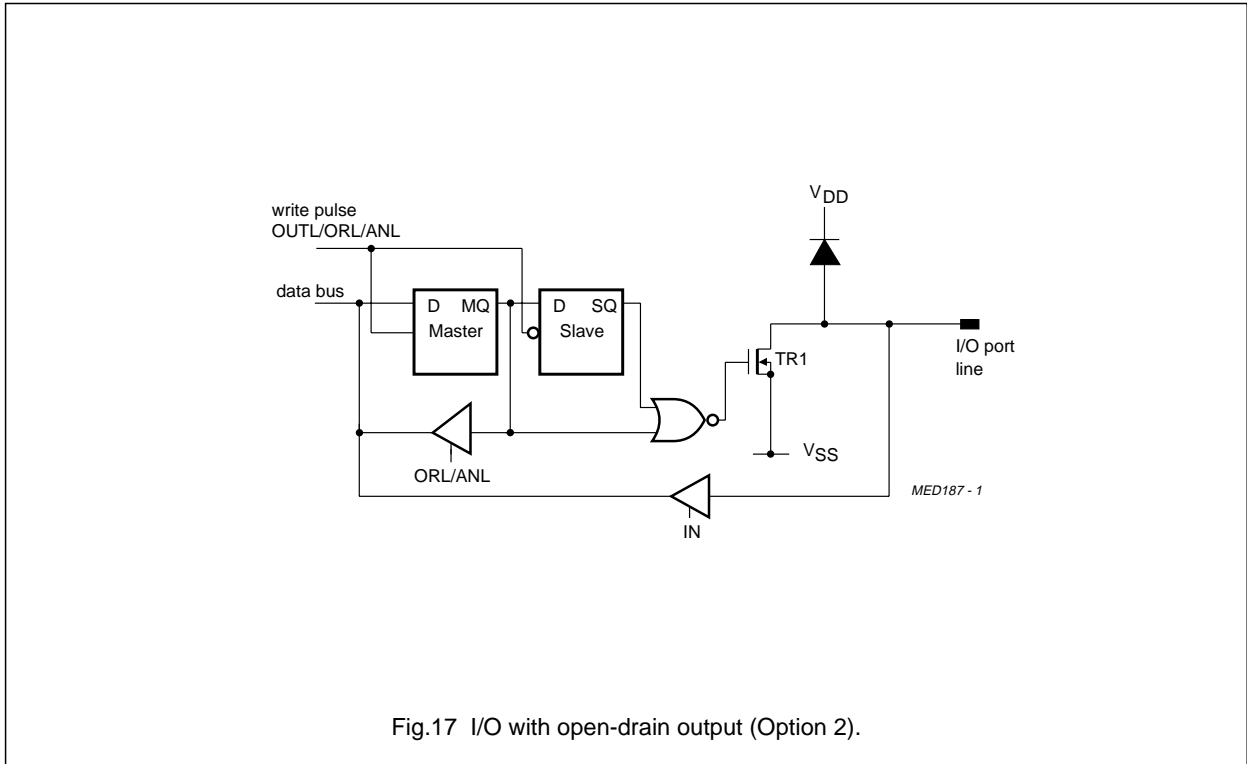

Fig.17 I/O with open-drain output (Option 2).

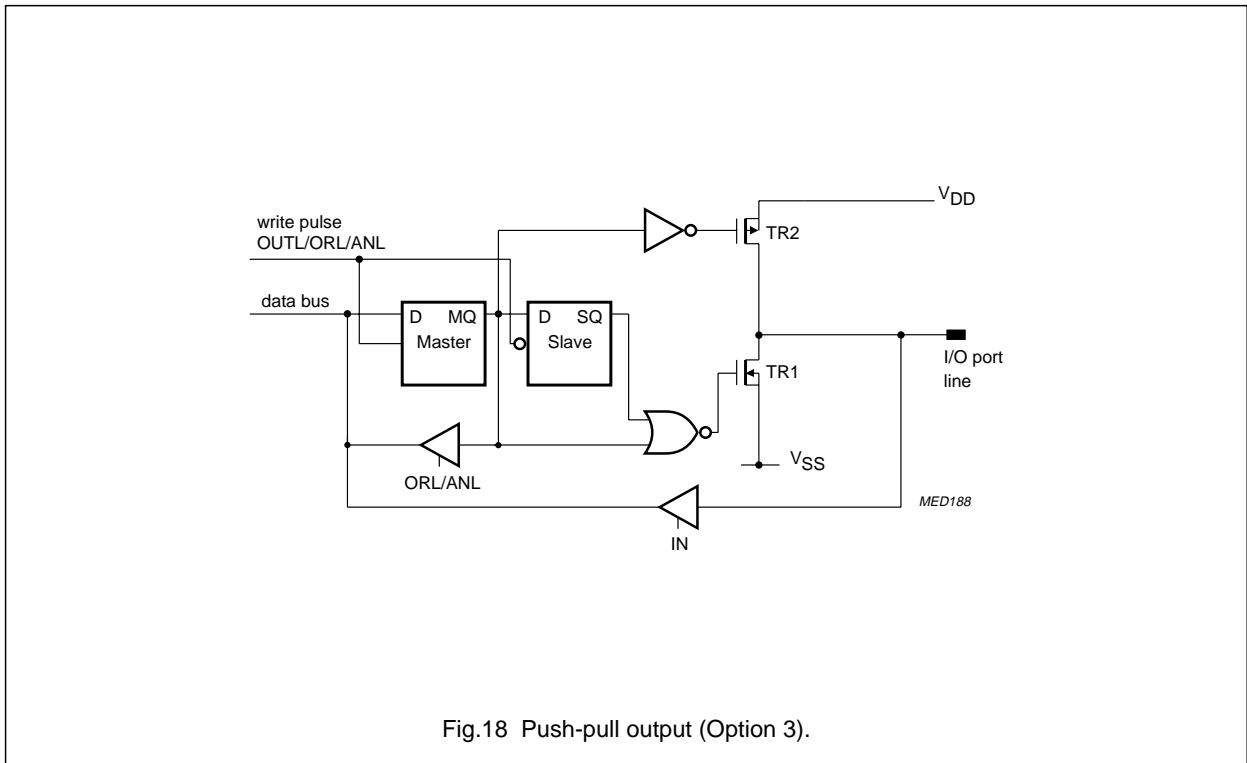

Fig.18 Push-pull output (Option 3).

Microcontrollers for universal infrared remote transmitter applications

PCA84C922; PCA84C923

11 INTERRUPTS

The PCA84C92X has three interrupt sources:

1. External keypad wake-up and $T0/\overline{INT}$ pin; vector address 03H.
2. Hardware Modulator; vector address 05H.
3. Internal Timer/counter (T1); vector address 07H.

11.1 External keypad wake-up and $T0/\overline{INT}$ pin interrupt

This interrupt will wake-up the CPU from the Stop mode when a HIGH-to-LOW transition occurs on any Port 1 pin or the $T0/\overline{INT}$ pin (see Fig.1); normal program execution will continue after a 1866 clock cycle delay.

If this interrupt was enabled (by using the 'EN I' instruction) before the Stop mode was entered, then when the CPU is woken-up, the instruction that follows the STOP instruction will be executed before diverting to the interrupt routine at vector address 03H. However, if the interrupt was not enabled before the Stop mode was entered, then when the CPU is woken-up the instruction that follows the STOP instruction will be executed.

11.2 Hardware Modulator interrupt

When a complete pulse train has been transmitted by the Hardware Modulator, it generates an interrupt to the CPU by asserting \overline{EXDI} and the operation of the Hardware Modulator is halted. This derivative interrupt is shared with the SIO interrupt of the PCF84CXXXA family; both use vector address 05H. The Hardware Modulator interrupt is enabled using the instruction 'EN SI' and is disabled using the 'DIS SI' instruction.

11.3 Internal Timer/counter (T1) interrupt

The Timer/counter and its interrupt are common to other members of the PCF84CXXXA family; all operate in a similar manner. The Timer/counter interrupt is enabled using the instruction 'EN TCNT1' and is disabled using the 'DIS TCNT1' instruction.

12 DERIVATIVE REGISTERS

The Derivative Registers residing at addresses 00 to 04H are dedicated to the Hardware Modulator; these registers are also common to the PCA84CX22 range of microcontrollers. The Derivative Registers residing at addresses 05 to 08H are used for accessing the Coding Table. The Derivative Registers memory map is shown in Table 9.

When the Coding Table is accessed data will be read from Derivative Port 5 terminal (address 05H) regardless of whether the internal or external Coding table was addressed. Details of accessing the internal or external Coding Tables are given in Section 8. As Derivative Port 6 latch is also connected to the High byte address of the internal Coding Table, writing data to Derivative Port 6 latch (address 08H) also addresses the Coding Table.

Microcontrollers for universal infrared
remote transmitter applications

PCA84C922; PCA84C923

Table 9 Derivative Registers memory map (see note 1)

ADDR (HEX)	REGISTER	7	6	5	4	3	2	1	0	R/W
00	ON-TIME	ON7 (X)	ON6 (X)	ON5 (X)	ON4 (X)	ON3 (X)	ON2 (X)	ON1 (X)	ON0 (X)	R/W
01	OFF-TIME	OFF7 (X)	OFF6 (X)	OFF5 (X)	OFF4 (X)	OFF3 (X)	OFF2 (X)	OFF1 (X)	OFF0 (X)	R/W
02	Pulse Counter Low (PULOW)	PUL7 (X)	PUL6 (X)	PUL5 (X)	PUL4 (X)	PUL3 (X)	PUL2 (X)	PUL1 (X)	PUL0 (X)	R/W
03	Hardware Modulator Control (HMCTL)	–	–	–	WRES ⁽²⁾ (X)	Rint ⁽²⁾ (X)	PWM (X)	LgP (X)	HF (X)	R/W
04	Pulse Counter High (PUHIGH)	–	–	–	–	–	–	PUL9 (X)	PUL8 (X)	R/W
05	Derivative Port 5 (terminal)	DP57/MD7 (X)	DP56/MD6 (X)	DP55/MD5 (X)	DP54/MD4 (X)	DP53/MD3 (X)	DP52/MD2 (X)	DP51/MD1 (X)	DP50/MD0 (X)	R
06	Derivative Port 6 (terminal)	DP67 (X)	DP66 (X)	DP65 (X)	DP64 (X)	DP63 (X)	DP62 (X)	DP61 (X)	DP60 (X)	R
07	Derivative Port 5 (latch)	DP57 (1)	DP56 (1)	DP55 (1)	DP54 (1)	DP53 (1)	DP52 (1)	DP51 (1)	DP50 (1)	R/W
08	Derivative Port 6 (latch)	DP67/MA15 (Mo)	DP66/MA14 (Mo)	DP65/MA13 (Mo)	DP64/MA12 (Mo)	DP63/MA11 (Mo)	DP62/MA10 (Mo)	DP61/MA9 (Mo)	DP60/MA8 (Mo)	R/W

Notes

- Values within parenthesis show the bit state after a reset operation. 'X' denotes an undefined state and 'Mo' denotes the state is selected by mask option.
- These bits are Write only.

Microcontrollers for universal infrared remote transmitter applications

PCA84C922; PCA84C923

13 EMULATION

The PCA84C923D can be used as the emulation chip for both the PCA84C92X and PCA84CX22 ranges of microcontrollers. The emulation system is shown in Fig.19.

A 64 kbyte EPROM (27C256) is used as the Coding Table and stores all data code. The EPROM should be removed when members of the PCA84CX22 range are being emulated.

The PCA84C923D has two additional outputs: $\overline{\text{INTO}}$ and RSTO which are used for emulation purposes only. The $\overline{\text{INTO}}$ output is the result of the AND operation carried out internally on the $\text{T0}/\overline{\text{INT}}$ and Port 1 inputs; this is shown in Fig.1. The RSTO output is the result of the OR operation carried out internally on the RESET input and the Watchdog Timer reset; this is also shown in Fig.1. The $\overline{\text{INTO}}$ and RSTO pins of the PCA84C923D are connected to the $\text{T0}/\overline{\text{INT}}$ and RESET pins of the bond-out chip, respectively.

The RESET and $\text{T0}/\overline{\text{INT}}$ inputs are connected to the corresponding pins of the PCA84C923D (in other 84CXXX emulation systems they are connected to the corresponding pins of the PCF84C00).

In the emulation mode, port lines P10 to P13 of the PCA84C923D are used as the inputs for derivative control signals $\overline{\text{DXWR}}$, $\overline{\text{DXRD}}$, DXALE and EXDIN . Therefore, port lines P20 to P23 (which are ANDed internally to emulate the wake-up function of port lines P10 to P13) are connected to port lines P10 to P13 of the bond-out chip. If port lines P14 to P17 of the PCA84C923D have been masked for the wake-up function, then they must not be connected to the corresponding pins of the bond-out chip. However, these sets of pins can be connected if the wake-up option has not been selected.

When the PCA84C923D is used as the emulation chip all ports should have the mask option 1S. After a Power-on-reset the only data that can be written to Derivative Port 5 is FFH.

When the PCF84C00 is used for emulation purposes its ports should have the mask option 1S. However, as some ports may be used as scan lines (for example Port 1 and Port 6) they will have mask options of 1R or 3R. In this case, after a Power-on-reset, these ports should have 00H written to them.

Microcontrollers for universal infrared remote transmitter applications

PCA84C922; PCA84C923

14 LIMITING VALUES

In accordance with the Absolute Maximum Rating System (IEC 34).

SYMBOL	PARAMETER	MIN.	MAX.	UNIT
V_{DD}	supply voltage	-0.5	+7.0	V
V_I	all input voltages on any pin with respect to ground (V_{SS})	-0.5	$V_{DD} + 0.5$	V
I_{OH}	maximum source current for all port lines	-	-5.0	mA
I_{OL}	maximum sink current for all port lines	-	5.0	mA
P_{tot}	total power dissipation	-	500	mW
T_{amb}	operating ambient temperature	-20	+70	°C
T_{stg}	storage temperature	-55	+125	°C

Microcontrollers for universal infrared remote transmitter applications

PCA84C922; PCA84C923

15 DC CHARACTERISTICS

$V_{DD} = 5\text{ V} \pm 10\%$; $V_{SS} = 0\text{ V}$; $T_{amb} = -25\text{ to }+50\text{ }^{\circ}\text{C}$; all voltages with respect to V_{SS} ; unless otherwise specified.

SYMBOL	PARAMETER	CONDITIONS	MIN.	TYP.	MAX.	UNIT
Supply						
V_{DD}	operating supply voltage		2.0	3.0	5.5	V
I_{DD}	operating supply current	$V_{DD} = 3\text{ V}$; $f_{xtal} = 3\text{ MHz}$	–	0.4	0.9	mA
		$V_{DD} = 5\text{ V}$; $f_{xtal} = 3\text{ MHz}$	–	0.9	1.8	mA
$I_{DD(ID)}$	supply current Idle mode	$V_{DD} = 3\text{ V}$; $f_{xtal} = 3\text{ MHz}$	–	0.2	0.4	mA
		$V_{DD} = 5\text{ V}$; $f_{xtal} = 3\text{ MHz}$	–	0.25	0.5	mA
$I_{DD(ST)}$	supply current Stop mode	$V_{DD} = 2\text{ V}$; $T_{amb} = 25\text{ }^{\circ}\text{C}$; note 1	–	1.2	2.4	μA
		$V_{DD} = 2\text{ V}$; $T_{amb} = 50\text{ }^{\circ}\text{C}$; note 1	–	–	10.0	μA
		$V_{DD} = 3\text{ V}$; $T_{amb} = 25\text{ }^{\circ}\text{C}$; note 1	–	1.2	2.4	μA
		$V_{DD} = 3\text{ V}$; $T_{amb} = 50\text{ }^{\circ}\text{C}$; note 1	–	–	10.0	μA
		$V_{DD} = 5\text{ V}$; $T_{amb} = 25\text{ }^{\circ}\text{C}$; note 1	–	1.2	2.4	μA
		$V_{DD} = 5\text{ V}$; $T_{amb} = 50\text{ }^{\circ}\text{C}$; note 1	–	–	10.0	μA
Inputs EMU; RESET; T0/INTN; T1; P00 to P07; P10 to P17; P20 to P23; DP50 to DP57 and DP60 to DP67						
V_{IL}	LOW level input voltage		0	–	$0.3V_{DD}$	V
V_{IH}	HIGH level input voltage		$0.7V_{DD}$	–	V_{DD}	V
I_{LI}	input leakage current	$V_{SS} < V_I < V_{DD}$	–	–	± 1	μA
Outputs P00 to P07; P10 to P17; DP50 to DP57; DP60 to DP67; INTN0 and RSTO						
I_{OL}	LOW level output sink current	$V_{DD} = 5\text{ V}$; $V_O = 0.4\text{ V}$	–	12	–	mA
I_{OH1}	HIGH level pull-up output source current	$V_{DD} = 5\text{ V}$; $V_O = 0.7V_{DD}$	–40	–100	–	μA
		$V_{DD} = 5\text{ V}$; $V_O = V_{SS}$	–	–140	–400	μA
I_{OH2}	HIGH level push-pull output source current	$V_{DD} = 5\text{ V}$; $V_O = V_{DD} - 0.4\text{ V}$	–	–7.0	–	mA
Outputs P20 to P23						
I_{OL}	LOW level output sink current	$V_{DD} = 3\text{ V}$; $V_O = 0.4\text{ V}$	10	–	–	mA
I_{OH1}	HIGH level pull-up output source current	$V_{DD} = 5\text{ V}$; $V_O = 0.7V_{DD}$	–40	–100	–	μA
		$V_{DD} = 5\text{ V}$; $V_O = V_{SS}$	–	–140	–400	μA
I_{OH2}	HIGH level push-pull output source current	$V_{DD} = 5\text{ V}$; $V_O = V_{DD} - 0.4\text{ V}$	–	–7.0	–	mA
Output LOUT						
I_{OL}	LOW level output sink current	$V_{DD} = 2\text{ V}$; $V_O = 1\text{ V}$	30	–	–	mA
I_{OH}	HIGH level output source current	$V_{DD} = 2\text{ V}$; $V_O = 1.6\text{ V}$	–1.6	–	–	mA

Note

- $f_{xtal} = 3\text{ MHz}$.

**Microcontrollers for universal infrared
remote transmitter applications**

PCA84C922; PCA84C923

16 AC CHARACTERISTICS

SYMBOL	PARAMETER	CONDITIONS	MIN.	TYP.	MAX.	UNIT
f _{xtal}	crystal oscillator frequency	V _{DD} = 2.5 to 5.5 V	1	–	6	MHz
		V _{DD} = 2 to 5.5 V	1	–	4.5	MHz
Transconductance						
g _{mL}	option LOW	V _{DD} = 5 V	0.3	0.7	1.4	mS
g _{mM}	option MEDIUM	V _{DD} = 5 V	0.9	1.6	3.2	mS
g _{mH}	option HIGH	V _{DD} = 5 V	3	4.5	9.0	mS
R _f	feedback resistor		0.3	1	3	MΩ

Microcontrollers for universal infrared remote transmitter applications

PCA84C922; PCA84C923

17 PACKAGE OUTLINES

VSO56: plastic very small outline package; 56 leads

SOT190-1

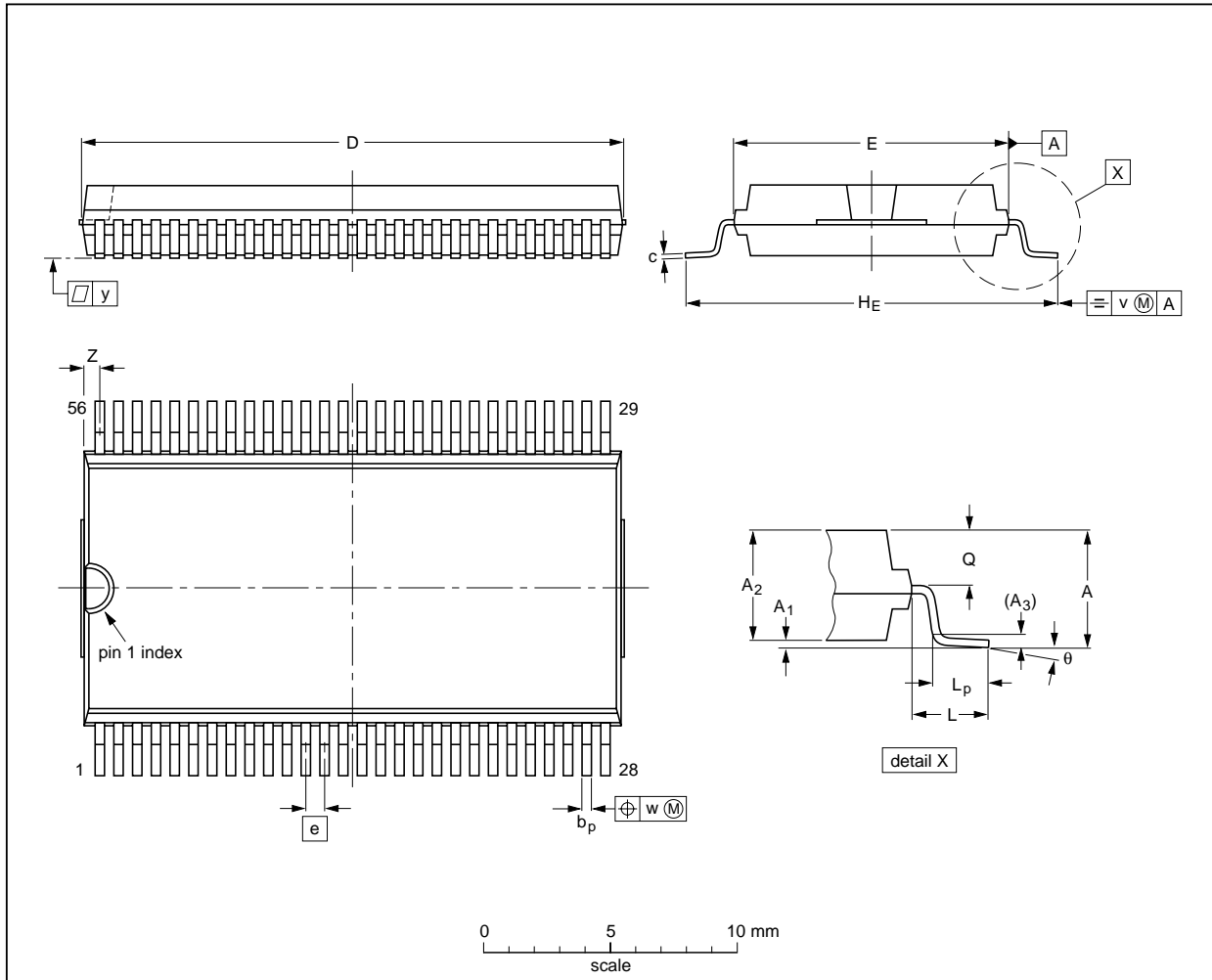

DIMENSIONS (inch dimensions are derived from the original mm dimensions)

UNIT	A max.	A ₁	A ₂	A ₃	b _p	c	D ⁽¹⁾	E ⁽²⁾	e	H _E	L	L _p	Q	v	w	y	z ⁽¹⁾	θ
mm	3.3	0.3 0.1	3.0 2.8	0.25	0.42 0.30	0.22 0.14	21.65 21.35	11.1 11.0	0.75	15.8 15.2	2.25	1.6 1.4	1.45 1.30	0.2	0.1	0.1	0.90 0.55	7° 0°
inches	0.13	0.012 0.004	0.12 0.11	0.01	0.017 0.012	0.0087 0.0055	0.85 0.84	0.44 0.43	0.0295	0.62 0.60	0.089	0.063 0.055	0.057 0.051	0.008	0.004	0.004	0.035 0.022	

Note

1. Plastic or metal protrusions of 0.3 mm maximum per side are not included.
2. Plastic interlead protrusions of 0.25 mm maximum per side are not included.

OUTLINE VERSION	REFERENCES				EUROPEAN PROJECTION	ISSUE DATE
	IEC	JEDEC	EIAJ			
SOT190-1						96-04-02- 97-08-11

Microcontrollers for universal infrared remote transmitter applications

PCA84C922; PCA84C923

SO28: plastic small outline package; 28 leads; body width 7.5 mm

SOT136-1

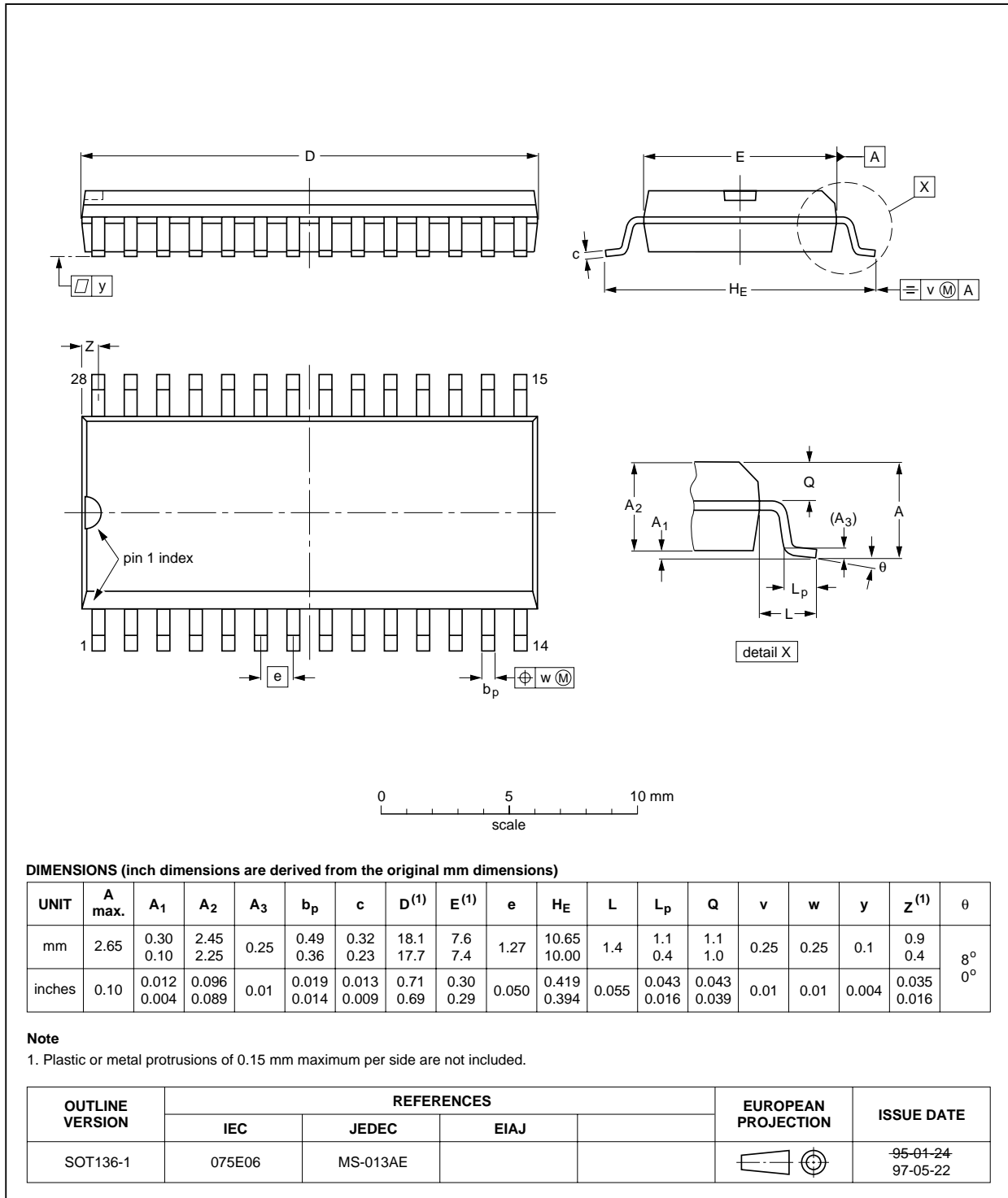

Microcontrollers for universal infrared remote transmitter applications

PCA84C922; PCA84C923

SO24: plastic small outline package; 24 leads; body width 7.5 mm

SOT137-1

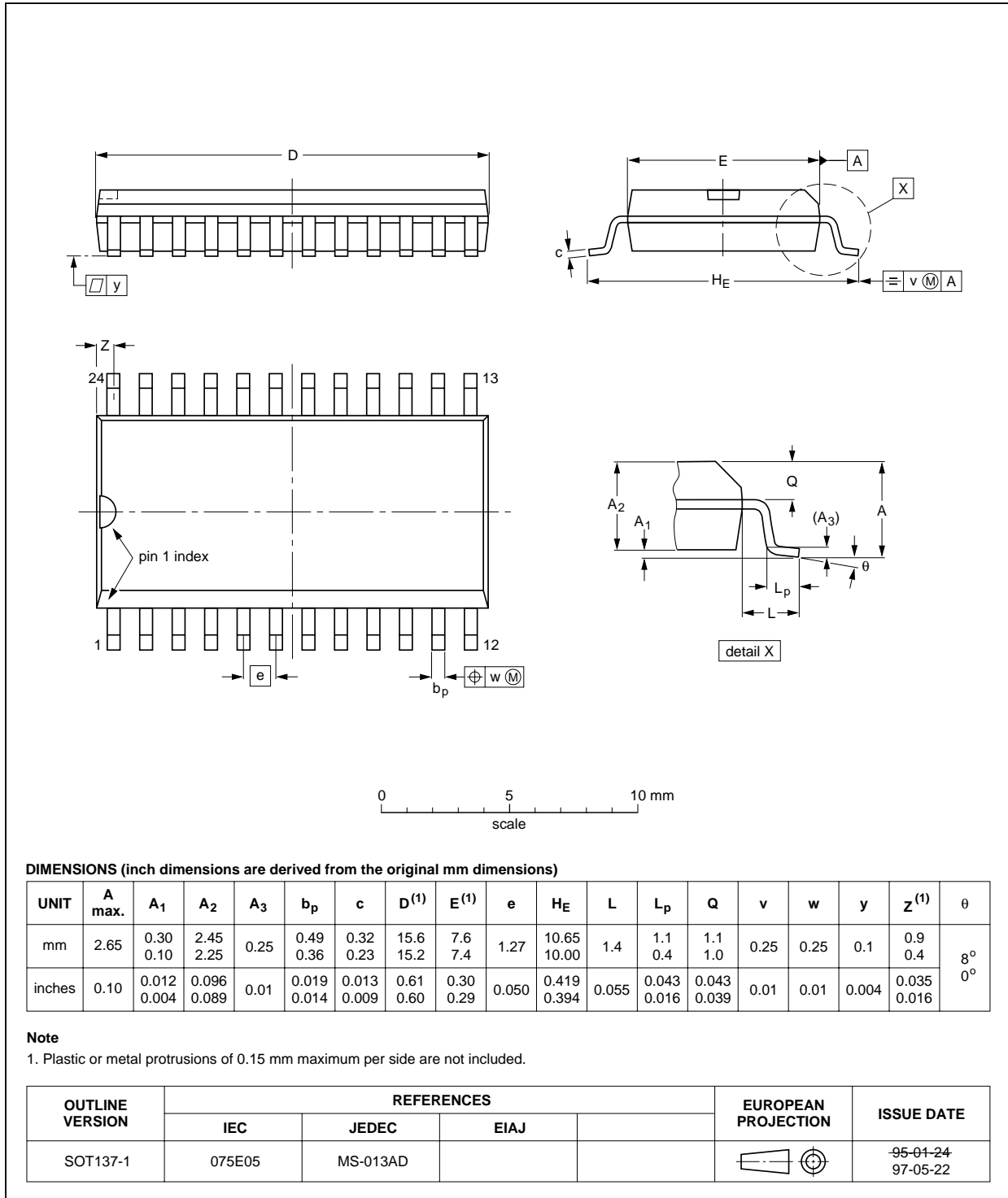

Microcontrollers for universal infrared remote transmitter applications

PCA84C922; PCA84C923

SDIP24: plastic shrink dual in-line package; 24 leads (400 mil)

SOT234-1

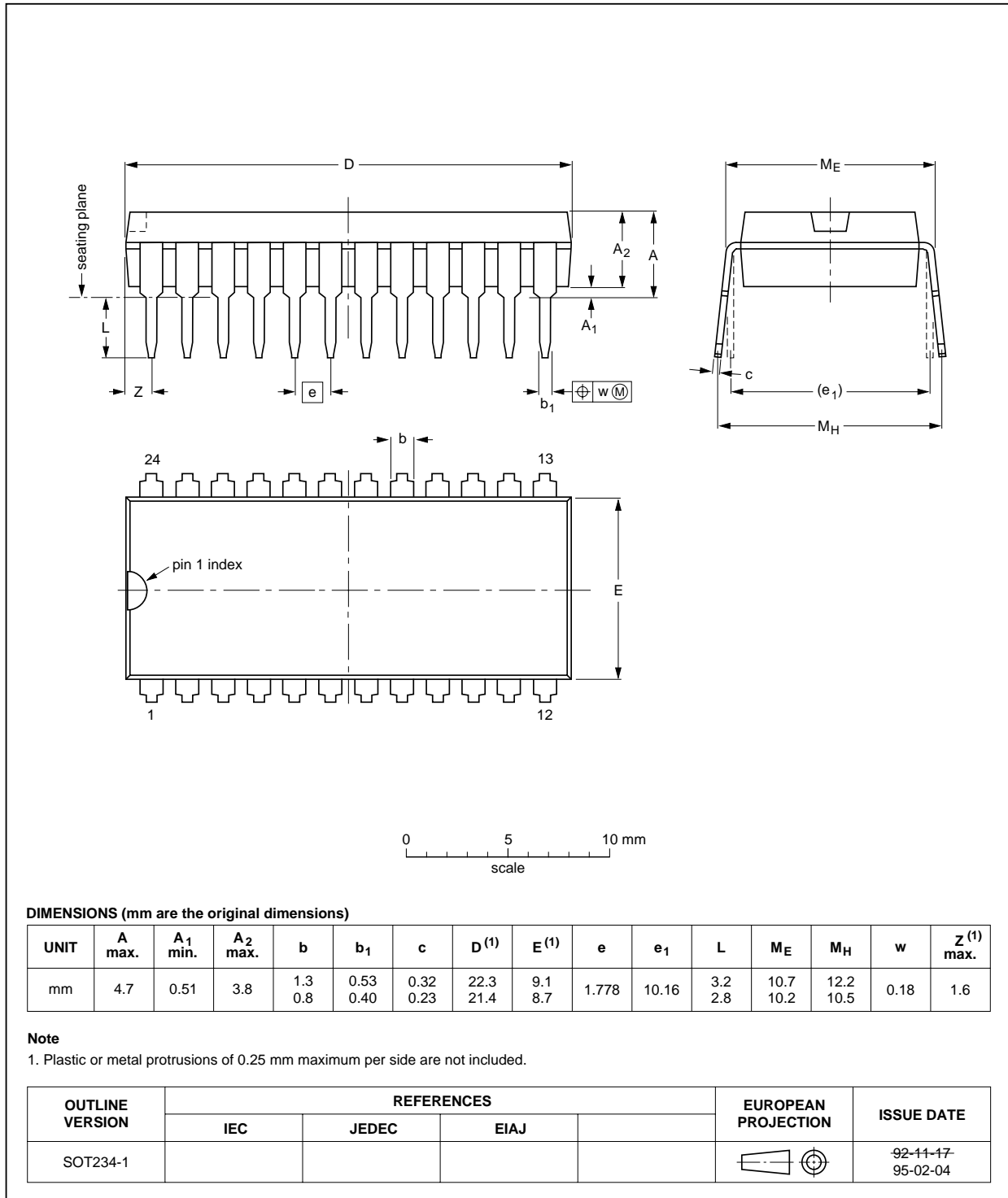

Microcontrollers for universal infrared remote transmitter applications

PCA84C922; PCA84C923

18 SOLDERING

18.1 Introduction

There is no soldering method that is ideal for all IC packages. Wave soldering is often preferred when through-hole and surface mounted components are mixed on one printed-circuit board. However, wave soldering is not always suitable for surface mounted ICs, or for printed-circuits with high population densities. In these situations reflow soldering is often used.

This text gives a very brief insight to a complex technology. A more in-depth account of soldering ICs can be found in our *"IC Package Databook"* (order code 9398 652 90011).

18.2 SDIP

18.2.1 SOLDERING BY DIPPING OR BY WAVE

The maximum permissible temperature of the solder is 260 °C; solder at this temperature must not be in contact with the joint for more than 5 seconds. The total contact time of successive solder waves must not exceed 5 seconds.

The device may be mounted up to the seating plane, but the temperature of the plastic body must not exceed the specified maximum storage temperature ($T_{stg\ max}$). If the printed-circuit board has been pre-heated, forced cooling may be necessary immediately after soldering to keep the temperature within the permissible limit.

18.2.2 REPAIRING SOLDERED JOINTS

Apply a low voltage soldering iron (less than 24 V) to the lead(s) of the package, below the seating plane or not more than 2 mm above it. If the temperature of the soldering iron bit is less than 300 °C it may remain in contact for up to 10 seconds. If the bit temperature is between 300 and 400 °C, contact may be up to 5 seconds.

18.3 SO and VSO

18.3.1 REFLOW SOLDERING

Reflow soldering techniques are suitable for all SO and VSO packages.

Reflow soldering requires solder paste (a suspension of fine solder particles, flux and binding agent) to be applied to the printed-circuit board by screen printing, stencilling or pressure-syringe dispensing before package placement.

Several techniques exist for reflowing; for example, thermal conduction by heated belt. Dwell times vary between 50 and 300 seconds depending on heating method. Typical reflow temperatures range from 215 to 250 °C.

Preheating is necessary to dry the paste and evaporate the binding agent. Preheating duration: 45 minutes at 45 °C.

18.3.2 WAVE SOLDERING

Wave soldering techniques can be used for all SO and VSO packages if the following conditions are observed:

- A double-wave (a turbulent wave with high upward pressure followed by a smooth laminar wave) soldering technique should be used.
- The longitudinal axis of the package footprint must be parallel to the solder flow.
- The package footprint must incorporate solder thieves at the downstream end.

During placement and before soldering, the package must be fixed with a droplet of adhesive. The adhesive can be applied by screen printing, pin transfer or syringe dispensing. The package can be soldered after the adhesive is cured.

Maximum permissible solder temperature is 260 °C, and maximum duration of package immersion in solder is 10 seconds, if cooled to less than 150 °C within 6 seconds. Typical dwell time is 4 seconds at 250 °C.

A mildly-activated flux will eliminate the need for removal of corrosive residues in most applications.

18.3.3 REPAIRING SOLDERED JOINTS

Fix the component by first soldering two diagonally-opposite end leads. Use only a low voltage soldering iron (less than 24 V) applied to the flat part of the lead. Contact time must be limited to 10 seconds at up to 300 °C. When using a dedicated tool, all other leads can be soldered in one operation within 2 to 5 seconds between 270 and 320 °C.

Microcontrollers for universal infrared remote transmitter applications

PCA84C922; PCA84C923

19 DEFINITIONS

Data sheet status	
Objective specification	This data sheet contains target or goal specifications for product development.
Preliminary specification	This data sheet contains preliminary data; supplementary data may be published later.
Product specification	This data sheet contains final product specifications.
Limiting values	
Limiting values given are in accordance with the Absolute Maximum Rating System (IEC 134). Stress above one or more of the limiting values may cause permanent damage to the device. These are stress ratings only and operation of the device at these or at any other conditions above those given in the Characteristics sections of the specification is not implied. Exposure to limiting values for extended periods may affect device reliability.	
Application information	
Where application information is given, it is advisory and does not form part of the specification.	

20 LIFE SUPPORT APPLICATIONS

These products are not designed for use in life support appliances, devices, or systems where malfunction of these products can reasonably be expected to result in personal injury. Philips customers using or selling these products for use in such applications do so at their own risk and agree to fully indemnify Philips for any damages resulting from such improper use or sale.

Microcontrollers for universal infrared
remote transmitter applications

PCA84C922; PCA84C923

NOTES

Philips Semiconductors – a worldwide company

Argentina: see South America

Australia: 34 Waterloo Road, NORTH RYDE, NSW 2113,
Tel. +61 2 9805 4455, Fax. +61 2 9805 4466

Austria: Computerstr. 6, A-1101 WIEN, P.O. Box 213, Tel. +43 160 1010,
Fax. +43 160 101 1210

Belarus: Hotel Minsk Business Center, Bld. 3, r. 1211, Volodarski Str. 6,
220050 MINSK, Tel. +375 172 200 733, Fax. +375 172 200 773

Belgium: see The Netherlands

Brazil: see South America

Bulgaria: Philips Bulgaria Ltd., Energoproject, 15th floor,
51 James Bourchier Blvd., 1407 SOFIA,
Tel. +359 2 689 211, Fax. +359 2 689 102

Canada: PHILIPS SEMICONDUCTORS/COMPONENTS,
Tel. +1 800 234 7381

China/Hong Kong: 501 Hong Kong Industrial Technology Centre,
72 Tat Chee Avenue, Kowloon Tong, HONG KONG,
Tel. +852 2319 7888, Fax. +852 2319 7700

Colombia: see South America

Czech Republic: see Austria

Denmark: Prags Boulevard 80, PB 1919, DK-2300 COPENHAGEN S,
Tel. +45 32 88 2636, Fax. +45 31 57 0044

Finland: Sinikalliontie 3, FIN-02630 ESPOO,
Tel. +358 9 615800, Fax. +358 9 61580920

France: 4 Rue du Port-aux-Vins, BP317, 92156 SURESNES Cedex,
Tel. +33 1 40 99 6161, Fax. +33 1 40 99 6427

Germany: Hammerbrookstraße 69, D-20097 HAMBURG,
Tel. +49 40 23 53 60, Fax. +49 40 23 536 300

Greece: No. 15, 25th March Street, GR 17778 TAVROS/ATHENS,
Tel. +30 1 4894 339/239, Fax. +30 1 4814 240

Hungary: see Austria

India: Philips INDIA Ltd, Band Box Building, 2nd floor,
254-D, Dr. Annie Besant Road, Worli, MUMBAI 400 025,
Tel. +91 22 493 8541, Fax. +91 22 493 0966

Indonesia: see Singapore

Ireland: Newstead, Clonskeagh, DUBLIN 14,
Tel. +353 1 7640 000, Fax. +353 1 7640 200

Israel: RAPAC Electronics, 7 Kehilat Saloniki St, PO Box 18053,
TEL AVIV 61180, Tel. +972 3 645 0444, Fax. +972 3 649 1007

Italy: PHILIPS SEMICONDUCTORS, Piazza IV Novembre 3,
20124 MILANO, Tel. +39 2 6752 2531, Fax. +39 2 6752 2557

Japan: Philips Bldg 13-37, Kohnan 2-chome, Minato-ku, TOKYO 108,
Tel. +81 3 3740 5130, Fax. +81 3 3740 5077

Korea: Philips House, 260-199 Itaewon-dong, Yongsan-ku, SEOUL,
Tel. +82 2 709 1412, Fax. +82 2 709 1415

Malaysia: No. 76 Jalan Universiti, 46200 PETALING JAYA, SELANGOR,
Tel. +60 3 750 5214, Fax. +60 3 757 4880

Mexico: 5900 Gateway East, Suite 200, EL PASO, TEXAS 79905,
Tel. +9-5 800 234 7381

Middle East: see Italy

Netherlands: Postbus 90050, 5600 PB EINDHOVEN, Bldg. VB,
Tel. +31 40 27 82785, Fax. +31 40 27 88399

New Zealand: 2 Wagener Place, C.P.O. Box 1041, AUCKLAND,
Tel. +64 9 849 4160, Fax. +64 9 849 7811

Norway: Box 1, Manglerud 0612, OSLO,
Tel. +47 22 74 8000, Fax. +47 22 74 8341

Philippines: Philips Semiconductors Philippines Inc.,
106 Valero St. Salcedo Village, P.O. Box 2108 MCC, MAKATI,
Metro MANILA, Tel. +63 2 816 6380, Fax. +63 2 817 3474

Poland: Ul. Lukiska 10, PL 04-123 WARSZAWA,
Tel. +48 22 612 2831, Fax. +48 22 612 2327

Portugal: see Spain

Romania: see Italy

Russia: Philips Russia, Ul. Usatcheva 35A, 119048 MOSCOW,
Tel. +7 095 755 6918, Fax. +7 095 755 6919

Singapore: Lorong 1, Toa Payoh, SINGAPORE 1231,
Tel. +65 350 2538, Fax. +65 251 6500

Slovakia: see Austria

Slovenia: see Italy

South Africa: S.A. PHILIPS Pty Ltd., 195-215 Main Road Martindale,
2092 JOHANNESBURG, P.O. Box 7430 Johannesburg 2000,
Tel. +27 11 470 5911, Fax. +27 11 470 5494

South America: Rua do Rocio 220, 5th floor, Suite 51,
04552-903 São Paulo, SÃO PAULO - SP, Brazil,
Tel. +55 11 821 2333, Fax. +55 11 829 1849

Spain: Balmes 22, 08007 BARCELONA,
Tel. +34 3 301 6312, Fax. +34 3 301 4107

Sweden: Kottbygatan 7, Akalla, S-16485 STOCKHOLM,
Tel. +46 8 632 2000, Fax. +46 8 632 2745

Switzerland: Allmendstrasse 140, CH-8027 ZÜRICH,
Tel. +41 1 488 2686, Fax. +41 1 481 7730

Taiwan: Philips Semiconductors, 6F, No. 96, Chien Kuo N. Rd., Sec. 1,
TAIPEI, Taiwan Tel. +886 2 2134 2865, Fax. +886 2 2134 2874

Thailand: PHILIPS ELECTRONICS (THAILAND) Ltd.,
209/2 Sanpavuth-Bangna Road Prakanong, BANGKOK 10260,
Tel. +66 2 745 4090, Fax. +66 2 398 0793

Turkey: Talatpasa Cad. No. 5, 80640 GÜLTEPE/ISTANBUL,
Tel. +90 212 279 2770, Fax. +90 212 282 6707

Ukraine: PHILIPS UKRAINE, 4 Patrice Lumumba str., Building B, Floor 7,
252042 KIEV, Tel. +380 44 264 2776, Fax. +380 44 268 0461

United Kingdom: Philips Semiconductors Ltd., 276 Bath Road, Hayes,
MIDDLESEX UB3 5BX, Tel. +44 181 730 5000, Fax. +44 181 754 8421

United States: 811 East Arques Avenue, SUNNYVALE, CA 94088-3409,
Tel. +1 800 234 7381

Uruguay: see South America

Vietnam: see Singapore

Yugoslavia: PHILIPS, Trg N. Pasica 5/v, 11000 BEOGRAD,
Tel. +381 11 625 344, Fax. +381 11 635 777

For all other countries apply to: Philips Semiconductors, Marketing & Sales Communications,
Building BE-p, P.O. Box 218, 5600 MD EINDHOVEN, The Netherlands, Fax. +31 40 27 24825

Internet: <http://www.semiconductors.philips.com>

© Philips Electronics N.V. 1997

SCA55

All rights are reserved. Reproduction in whole or in part is prohibited without the prior written consent of the copyright owner.

The information presented in this document does not form part of any quotation or contract, is believed to be accurate and reliable and may be changed without notice. No liability will be accepted by the publisher for any consequence of its use. Publication thereof does not convey nor imply any license under patent- or other industrial or intellectual property rights.

Printed in The Netherlands

457027/00/02/pp36

Date of release: 1997 Oct 22

Document order number: 9397 750 02973

Let's make things better.

**Philips
Semiconductors**



PHILIPS