



# PCF2129A

Integrated RTC, TCXO and quartz crystal

Rev. 01 — 13 January 2010

Product data sheet

## 1. General description

The PCF2129A is a CMOS<sup>1</sup> real time clock and calendar with an integrated Temperature Compensated Crystal (Xtal) Oscillator (TCXO) and a 32.768 kHz quartz crystal optimized for very high accuracy and very low power consumption. The PCF2129A has a selectable I<sup>2</sup>C-bus or SPI-bus, a backup battery switch-over circuit, a programmable watchdog function, a timestamp function, and many other features.

## 2. Features

- Temperature Compensated Crystal Oscillator (TCXO) with integrated capacitors
- Accuracy:  $\pm 3$  ppm from  $-15$  °C to  $+60$  °C
- Integration of a 32.768 kHz quartz crystal and oscillator in the same package
- Provides year, month, day, weekday, hours, minutes, and seconds
- Timestamp function
  - ◆ with interrupt capability
  - ◆ detection of two different events on one multilevel input pin (e.g. for tamper detection)
- Two line bidirectional 1 MHz Fast-mode Plus (Fm+) I<sup>2</sup>C-bus interface ( $I_{OL} = 20$  mA at pin SDA)
- 3 line SPI-bus with separate data input and output (maximum speed 6.5 Mbit/s)
- Battery backup input pin and switch-over circuitry
- Battery backed output voltage pin
- Battery low detection function
- Extra power fail detection function with input and output pins
- Power-On Reset Override (PORO)
- Oscillator stop detection function
- Interrupt output (open-drain)
- Programmable 1 second or 1 minute interrupt
- Programmable watchdog timer with interrupt and reset capability
- Programmable alarm function with interrupt capability
- Programmable square wave open-drain output pin
- Clock operating voltage: 1.2 V to 4.2 V
- Low supply current: typical 0.65  $\mu$ A at  $V_{DD} = 3.0$  V and  $T_{amb} = 25$  °C
- Automatic leap year correction

1. The definition of the abbreviations and acronyms used in this data sheet can be found in [Section 17](#).

### 3. Applications

- Electronic metering for electricity, water, and gas
- Timekeeping instruments with high precision
- GPS equipment to reduce time to first fix
- Applications that require an accurate process timing
- Products with long automated unattended operation time

### 4. Ordering information

Table 1. Ordering information

| Type number | Package |  |          |
|-------------|---------|--|----------|
|             | Name    | Description  | Version  |
| PCF2129AT/1 | SO20    | plastic small outline package; 20 leads; body width 7.5 mm | SOT163-1 |

### 5. Marking

Table 2. Marking codes

| Type number | Marking code |
|-------------|--------------|
| PCF2129AT/1 | PCF2129AT    |

6. Block diagram

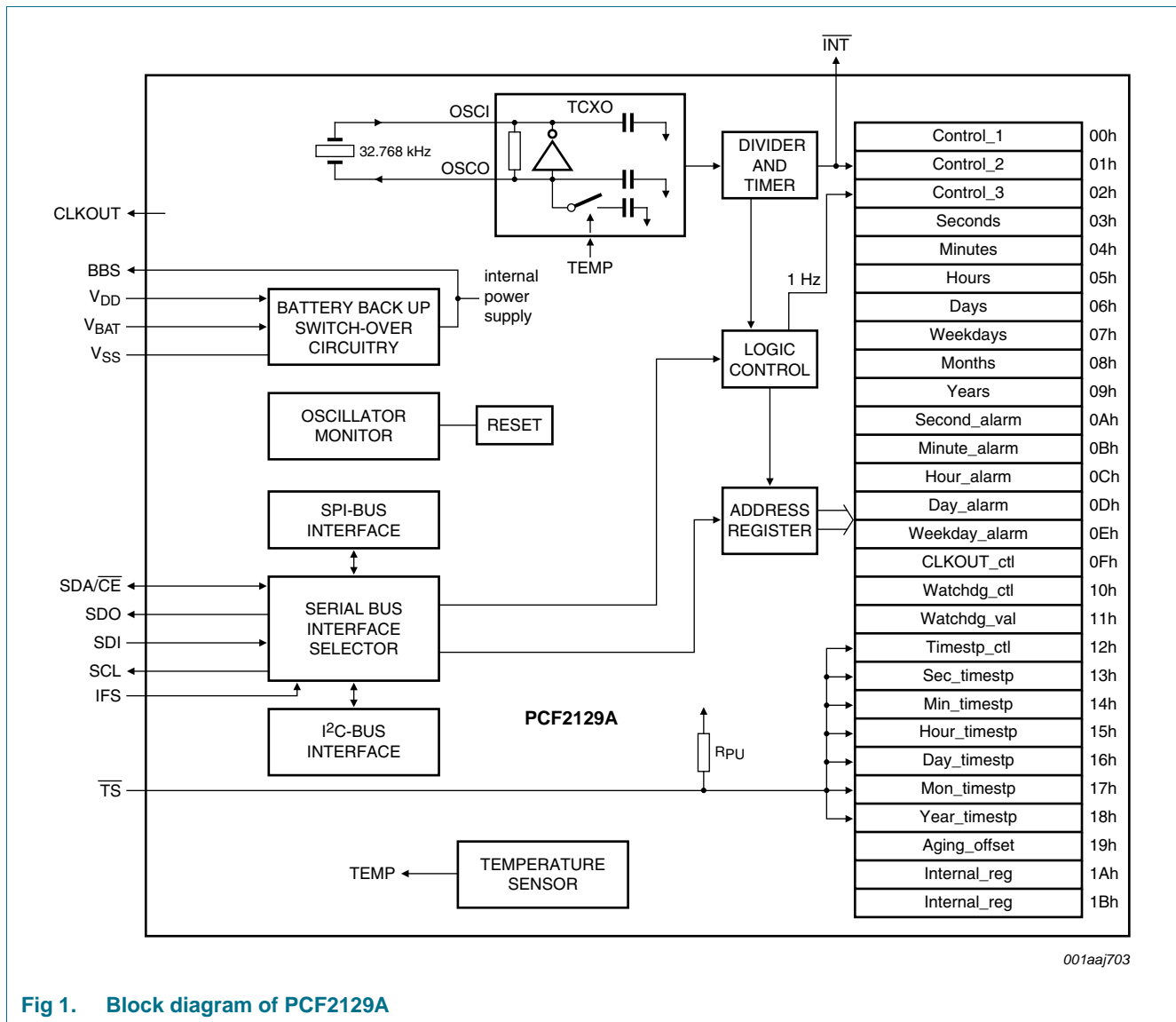
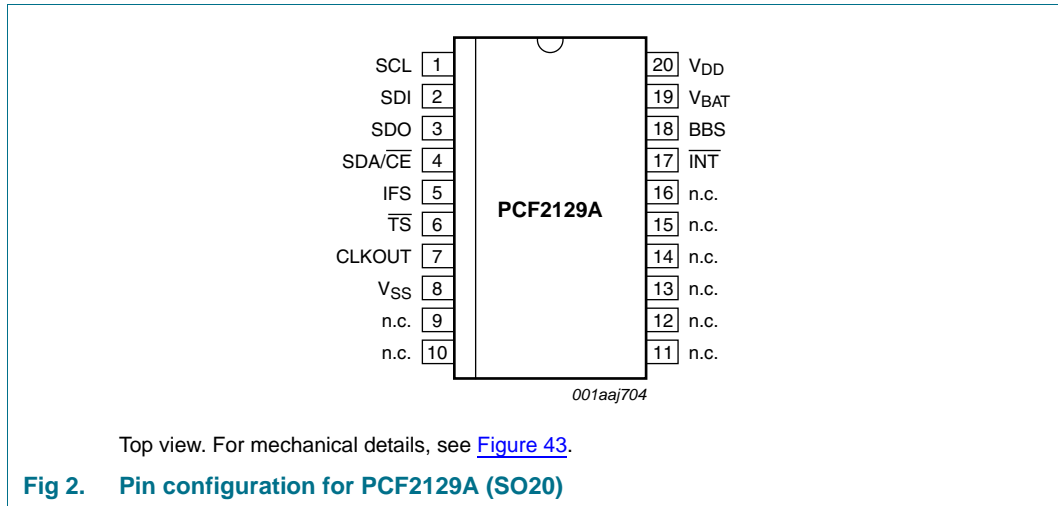

Fig 1. Block diagram of PCF2129A

## 7. Pinning information

### 7.1 Pinning



### 7.2 Pin description

**Table 3. Pin description of PCF2129A**

| Symbol               | Pin     | Description   |
|----------------------|---------|---|
| SCL                  | 1       | combined serial clock input for both I <sup>2</sup> C-bus and SPI-bus; may float when $\overline{CE}$ inactive                            |
| SDI                  | 2       | serial data input for SPI-bus; may float when $\overline{CE}$ inactive  |
| SDO                  | 3       | serial data output for SPI-bus, push-pull   |
| SDA/ $\overline{CE}$ | 4       | combined serial data input and output for the I <sup>2</sup> C-bus and chip enable input (active LOW) for the SPI-bus                     |
| IFS                  | 5       | interface selector input<br>connect to pin V <sub>SS</sub> to select the SPI-bus<br>connect to pin BBS to select the I <sup>2</sup> C-bus |
| $\overline{TS}$      | 6       | timestamp input (active LOW) with 200 kΩ internal pull-up resistor (R <sub>PU</sub> )   |
| CLKOUT               | 7       | clock output (open-drain)   |
| V <sub>SS</sub>      | 8       | ground supply voltage   |
| n.c.                 | 9 to 16 | not connected; do not connect; do not use as feed through   |
| $\overline{INT}$     | 17      | interrupt output (open-drain; active LOW)   |
| BBS                  | 18      | output voltage (battery backed)   |
| V <sub>BAT</sub>     | 19      | battery supply voltage (backup)   |
| V <sub>DD</sub>      | 20      | supply voltage  |

## 8. Functional description

The PCF2129A is a Real Time Clock and calendar (RTC) with an on-chip Temperature Compensated crystal (Xtal) Oscillator (TCXO) and a 32.768 kHz quartz crystal integrated into the same package.

Address and data are transferred by a selectable 1 MHz Fast-mode Plus (Fm+) I<sup>2</sup>C-bus or a 3 line SPI-bus with separate data input and output (see [Section 9](#)). The maximum speed of the SPI-bus is 6.5 Mbit/s.

The PCF2129A contains 28 8-bit registers, that are used for many different functions, such as clock, alarm, watchdog, timestamp etc. (see [Section 8.1](#)).

The PCF2129A has a backup battery input pin and backup battery switch-over circuit which monitors the main power supply and automatically switches to the backup battery when a power failure condition is detected (see [Section 8.5.1](#)). Accurate timekeeping is maintained even when the main power supply is interrupted.

A battery low detection circuit monitors the status of the battery (see [Section 8.5.3](#)). When the battery voltage goes below a threshold value, a flag is set to indicate that the battery must be replaced soon. This ensures the integrity of the data during periods of battery backup.

### 8.1 Register overview

The PCF2129A contains 28 8-bit registers (see [Table 4](#)) with an auto-incrementing address register: the built-in address register will increment automatically after each read or write of a data byte up to the register 1Bh. After register 1Bh the auto-incrementing will wrap around to address 00h.

- The first three registers (memory address 00h, 01h, and 02h) are used as control registers (see [Section 8.2](#)).
- The memory addresses 03h through to 09h are used as counters for the clock function (seconds up to years). The date is automatically adjusted for months with fewer than 31 days, including corrections for leap years. The clock can operate in 12-hour mode with an AM/PM indication or in 24-hour mode (see [Section 8.8](#)).
- Addresses 0Ah through 0Eh define the alarm function. It can be selected that an interrupt is generated when an alarm event occurs (see [Section 8.9](#)).
- The register 0Fh defines the temperature measurement period and the clock out mode. The temperature measurement can be selected from every 4 minutes (default) down to every 30 seconds (see [Table 9](#)). CLKOUT frequencies of 32.768 kHz (default) down to 1 Hz for use as a system clock, a microcontroller clock etc. can be chosen (see [Section 8.3.2](#)).
- Address registers 10h and 11h are used for the watchdog timer functions. The watchdog timer has four selectable source clocks allowing for timer periods from less than 1 ms to greater than 4 hours. An interrupt will be generated when the watchdog times out.
- Address registers 12h to 18h are used for the timestamp function. When the trigger event happens, the actual time is saved in the timestamp registers (see [Section 8.11](#)).
- Address register 19h is used for the correction of the crystal aging effect (see [Section 8.4.1](#)).

- Address registers 1Ah and 1Bh are for internal use only.
- The registers Seconds, Minutes, Hours, Days, Months, and Years are all coded in Binary Coded Decimal (BCD) format to simplify application use. Other registers are either bit-wise or standard binary.

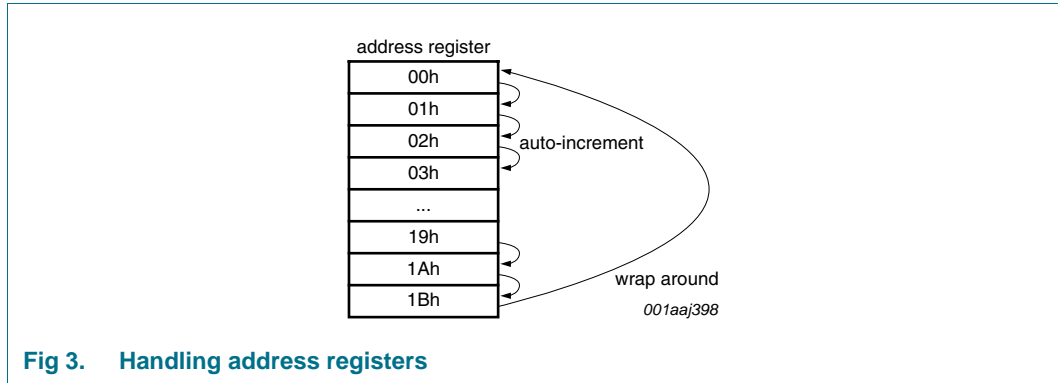

Fig 3. Handling address registers

When one of the RTC registers is read, the content of all counters is temporarily frozen. This prevents a faulty reading of the clock and calendar during a carry condition (see [Section 8.8.8](#)).

Table 4. Register overview

Bit positions labeled as - are not implemented and will return 0 when read. Bits labeled as T must always be written with logic 0. Bits labeled as X are undefined at power-on and unchanged by subsequent resets.

| Address                        | Register name | Bit             |                        |                                   |                                   |           |                        |              |      | Reset value   |
|--------------------------------|---------------|-----------------|------------------------|-----------------------------------|-----------------------------------|-----------|------------------------|--------------|------|---------------|
|                                |               | 7               | 6                      | 5                                 | 4                                 | 3         | 2                      | 1            | 0    |               |
| <b>Control registers</b>       |               |                 |                        |                                   |                                   |           |                        |              |      |               |
| 00h                            | Control_1     | EXT_TEST        | T                      | STOP                              | TSF1                              | POR_OVRD  | 12_24                  | MI           | SI   | 0000 0000     |
| 01h                            | Control_2     | MSF             | WDTF                   | TSF2                              | AF                                | T         | TSIE                   | AIE          | T    | 0000 0000     |
| 02h                            | Control_3     | PWRMNG[2:0]     |                        |                                   | BTSE                              | BF        | BLF                    | BIE          | BLIE | 0000 0000     |
| <b>Time and date registers</b> |               |                 |                        |                                   |                                   |           |                        |              |      |               |
| 03h                            | Seconds       | OSF             | SECONDS (0 to 59)      |                                   |                                   |           | 1XXX XXXX              |              |      |               |
| 04h                            | Minutes       | -               | MINUTES (0 to 59)      |                                   |                                   |           | - XXX XXXX             |              |      |               |
| 05h                            | Hours         | -               | -                      | AMPM                              | HOURS (1 to 12) in 12 h mode      |           |                        | - - XX XXXX  |      |               |
|                                |               |                 |                        | HOURS (0 to 23) in 24 h mode      |                                   |           |                        | - - XX XXXX  |      |               |
| 06h                            | Days          | -               | -                      | DAYS (1 to 31)                    |                                   |           | - - XX XXXX            |              |      |               |
| 07h                            | Weekdays      | -               | -                      | -                                 | -                                 | -         | WEEKDAYS (0 to 6)      |              |      | - - - - - XXX |
| 08h                            | Months        | -               | -                      | -                                 | MONTHS (1 to 12)                  |           |                        | - - - X XXXX |      |               |
| 09h                            | Years         | YEARS (0 to 99) |                        |                                   |                                   | XXXX XXXX |                        |              |      |               |
| <b>Alarm registers</b>         |               |                 |                        |                                   |                                   |           |                        |              |      |               |
| 0Ah                            | Second_alarm  | AE_S            | SECOND_ALARM (0 to 59) |                                   |                                   |           | 1XXX XXXX              |              |      |               |
| 0Bh                            | Minute_alarm  | AE_M            | MINUTE_ALARM (0 to 59) |                                   |                                   |           | 1XXX XXXX              |              |      |               |
| 0Ch                            | Hour_alarm    | AE_H            | -                      | AMPM                              | HOUR_ALARM (1 to 12) in 12 h mode |           |                        | 1 - XX XXXX  |      |               |
|                                |               |                 |                        | HOUR_ALARM (0 to 23) in 24 h mode |                                   |           |                        | 1 - XX XXXX  |      |               |
| 0Dh                            | Day_alarm     | AE_D            | -                      | DAY_ALARM (1 to 31)               |                                   |           | 1 - XX XXXX            |              |      |               |
| 0Eh                            | Weekday_alarm | AE_W            | -                      | -                                 | -                                 | -         | WEEKDAY_ALARM (0 to 6) |              |      | 1 - - - - XXX |

**Table 4. Register overview ...continued**

Bit positions labeled as - are not implemented and will return 0 when read. Bits labeled as T must always be written with logic 0. Bits labeled as X are undefined at power-on and unchanged by subsequent resets.

| Address                        | Register name   | Bit                          |       |                                       |                                       |         |          |              |              | Reset value     |            |
|--------------------------------|-----------------|------------------------------|-------|---------------------------------------|---------------------------------------|---------|----------|--------------|--------------|-----------------|------------|
|                                |                 | 7                            | 6     | 5                                     | 4                                     | 3       | 2        | 1            | 0            |                 |            |
| <b>CLKOUT control register</b> |                 |                              |       |                                       |                                       |         |          |              |              |                 |            |
| 0Fh                            | CLKOUT_ctl      | TCR[1:0]                     |       | -                                     | -                                     | -       | COF[2:0] |              | 00 - - - 000 |                 |            |
| <b>Watchdog registers</b>      |                 |                              |       |                                       |                                       |         |          |              |              |                 |            |
| 10h                            | Watchdg_tim_ctl | WD_CD                        | T     | TI_TP                                 | -                                     | -       | -        | TF[1:0]      |              | 000 - - - 11    |            |
| 11h                            | Watchdg_tim_val | WATCHDGD_TIM_VAL[7:0]        |       |                                       |                                       |         |          |              |              | XXXX XXXX       |            |
| <b>Timestamp registers</b>     |                 |                              |       |                                       |                                       |         |          |              |              |                 |            |
| 12h                            | Timestamp_ctl   | TSM                          | TSOFF | -                                     | 1_O_16_TIMESTAMP[4:0]                 |         |          |              | 00 - X XXXX  |                 |            |
| 13h                            | Sec_timestp     | - SECOND_TIMESTAMP (0 to 59) |       |                                       |                                       |         |          |              |              |                 | - XXX XXXX |
| 14h                            | Min_timestp     | - MINUTE_TIMESTAMP (0 to 59) |       |                                       |                                       |         |          |              |              |                 | - XXX XXXX |
| 15h                            | Hour_timestp    | -                            | -     | AMPM                                  | HOUR_TIMESTAMP (1 to 12) in 12 h mode |         |          |              | - - XX XXXX  |                 |            |
|                                |                 |                              |       | HOUR_TIMESTAMP (0 to 23) in 24 h mode |                                       |         |          | - - XX XXXX  |              |                 |            |
| 16h                            | Day_timestp     | -                            | -     | DAY_TIMESTAMP (1 to 31)               |                                       |         |          | - - XX XXXX  |              |                 |            |
| 17h                            | Mon_timestp     | -                            | -     | -                                     | MONTH_TIMESTAMP (1 to 12)             |         |          |              | - - - X XXXX |                 |            |
| 18h                            | Year_timestp    | YEAR_TIMESTAMP (0 to 99)     |       |                                       |                                       |         |          |              |              | XXXX XXXX       |            |
| <b>Ageing offset register</b>  |                 |                              |       |                                       |                                       |         |          |              |              |                 |            |
| 19h                            | Ageing_offset   | -                            | -     | -                                     | -                                     | AO[3:0] |          | - - - - 1000 |              |                 |            |
| <b>Internal registers</b>      |                 |                              |       |                                       |                                       |         |          |              |              |                 |            |
| 1Ah                            | Internal_reg    | -                            | -     | -                                     | -                                     | -       | -        | -            | -            | - - - - - - - - |            |
| 1Bh                            | Internal_reg    | -                            | -     | -                                     | -                                     | -       | -        | -            | -            | - - - - - - - - |            |

## 8.2 Control registers

PCF2129A has 28 8-bit registers. The first 3 registers with the addresses 00h, 01h, and 02h are used as control registers.

### 8.2.1 Register Control\_1

**Table 5. Control\_1 - control and status register 1 (address 00h) bit description**

| Bit | Symbol   | Value | Description  | Reference                      |
|-----|----------|-------|--|--------------------------------|
| 7   | EXT_TEST | 0     | [1] normal mode  | <a href="#">Section 8.13</a>   |
|     |          | 1     | external clock test mode   |                                |
| 6   | T        | 0     | [2] unused   | -                              |
| 5   | STOP     | 0     | [1] RTC source clock runs  | <a href="#">Section 8.14</a>   |
|     |          | 1     | RTC clock is stopped;<br>RTC divider chain flip-flops are asynchronously set logic 0;<br>CLKOUT at 32.768 kHz, 16.384 kHz, or 8.192 kHz is still available |                                |
| 4   | TSF1     | 0     | [1] no timestamp interrupt generated   | <a href="#">Section 8.11.1</a> |
|     |          | 1     | flag set when $\overline{TS}$ input is driven to an intermediate level between power supply and ground;<br>flag must be cleared to clear interrupt         |                                |
| 3   | POR_OVRD | 0     | Power-On Reset Override (PORO) facility disabled;<br><b>set logic 0 for normal operation</b>   | <a href="#">Section 8.7.2</a>  |
|     |          | 1     | [1] PORO enabled   |                                |
| 2   | 12_24    | 0     | [1] 24 hour mode selected  | <a href="#">Table 18</a>       |
|     |          | 1     | 12 hour mode selected  |                                |
| 1   | MI       | 0     | [1] minute interrupt disabled  | <a href="#">Section 8.12.1</a> |
|     |          | 1     | minute interrupt enabled   |                                |
| 0   | SI       | 0     | [1] second interrupt disabled  |                                |
|     |          | 1     | second interrupt enabled   |                                |

[1] Default value.

[2] When writing to the register this bit has always to be set logic 0.



## 8.2.2 Register Control\_2

Table 6. Control\_2 - control and status register 2 (address 01h) bit description

| Bit | Symbol | Value | Description   | Reference                      |
|-----|--------|-------|---|--------------------------------|
| 7   | MSF    | 0     | [1] no minute or second interrupt generated   | <a href="#">Section 8.12</a>   |
|     |        | 1     | flag set when minute or second interrupt generated;<br>flag must be cleared to clear interrupt                          |                                |
| 6   | WDTF   | 0     | [1] no watchdog timer interrupt or reset generated  | <a href="#">Section 8.12.3</a> |
|     |        | 1     | flag set when watchdog timer interrupt or reset generated;<br>flag cannot be cleared by using the interface (read-only) |                                |
| 5   | TSF2   | 0     | [1] no timestamp interrupt generated  | <a href="#">Section 8.11.1</a> |
|     |        | 1     | flag set when $\overline{\text{TS}}$ input is driven to ground;<br>flag must be cleared to clear interrupt              |                                |
| 4   | AF     | 0     | [1] no alarm interrupt generated  | <a href="#">Section 8.9.6</a>  |
|     |        | 1     | flag set when alarm triggered;<br>flag must be cleared to clear interrupt   |                                |
| 3   | T      | 0     | [2] unused  | -                              |
| 2   | TSIE   | 0     | [1] no interrupt generated from timestamp flag  | <a href="#">Section 8.12.5</a> |
|     |        | 1     | interrupt generated when timestamp flag set   |                                |
| 1   | AIE    | 0     | [1] no interrupt generated from the alarm flag  | <a href="#">Section 8.12.4</a> |
|     |        | 1     | interrupt generated when alarm flag set   |                                |
| 0   | T      | 0     | [2] unused  | -                              |

[1] Default value.

[2] When writing to the register this bit has always to be set logic 0.

### 8.2.3 Register Control\_3

**Table 7. Control\_3 - control and status register 3 (address 0Fh) bit description**

| Bit    | Symbol      | Value | Description   | Reference                      |
|--------|-------------|-------|---|--------------------------------|
| 7 to 5 | PWRMNG[2:0] | [1]   | control of the battery switch-over, battery low detection, and extra power fail detection functions | <a href="#">Section 8.5</a>    |
| 4      | BTSE        | 0     | [2] no timestamp when battery switch-over occurs  | <a href="#">Section 8.11.4</a> |
|        |             | 1     | time-stamped when battery switch-over occurs  |                                |
| 3      | BF          | 0     | [2] no battery switch-over interrupt generated  | <a href="#">Section 8.5.1</a>  |
|        |             | 1     | flag set when battery switch-over occurs; flag must be cleared to clear interrupt                   |                                |
| 2      | BLF         | 0     | [2] battery status ok; no battery low interrupt generated   | <a href="#">Section 8.5.3</a>  |
|        |             | 1     | battery status low; flag cannot be cleared using the interface                                      |                                |
| 1      | BIE         | 0     | [2] no interrupt generated from the battery flag (BF)   | <a href="#">Section 8.12.6</a> |
|        |             | 1     | interrupt generated when BF is set  |                                |
| 0      | BLIE        | 0     | [2] no interrupt generated from battery low flag (BLF)  | <a href="#">Section 8.12.7</a> |
|        |             | 1     | interrupt generated when BLF is set   |                                |

[1] Values see [Table 13](#).

[2] Default value.

### 8.3 Register CLKOUT\_ctl

**Table 8. CLKOUT\_ctl - CLKOUT control register (address 03h) bit description**

| Bit    | Symbol   | Value                        | Description                    |
|--------|----------|------------------------------|--------------------------------|
| 7 to 6 | TCR[1:0] | see <a href="#">Table 9</a>  | temperature measurement period |
| 5 to 3 | -        | -                            | unused                         |
| 2 to 0 | COF[2:0] | see <a href="#">Table 10</a> | CLKOUT frequency selection     |

#### 8.3.1 Temperature compensated crystal oscillator

The frequency of tuning fork quartz crystal oscillators are temperature-dependent. In the PCF2129A the frequency drift caused by temperature variation is corrected by adjusting the load capacitance of the crystal oscillator.

The load capacitance is changed by switching between two load capacitance values using a modulation signal with a programmable duty cycle. Every chip is calibrated in order to produce, at the measured temperature, the correct duty cycle which compensates for the frequency shift.

The frequency accuracy can be evaluated by measuring the frequency of the square wave signal available at the output pin CLKOUT. However, the selection of  $f_{CLKOUT} = 32.768$  kHz (default value) leads to inaccurate measurements. The most accurate frequency measurement occurs when  $f_{CLKOUT} = 1$  Hz is selected (see [Table 10](#)).

##### 8.3.1.1 Temperature measurement

The PCF2129A has a temperature sensor circuit used to perform the temperature compensation of the frequency. The temperature is measured immediately after power-on and then periodically with a period set by the temperature conversion rate TCR[1:0] in the register CLKOUT\_ctl.

**Table 9. Temperature measurement period**

| TCR[1:0] | Temperature measurement period |
|----------|--------------------------------|
| 00       | <a href="#">[1]</a> 4 min      |
| 01       | 2 min                          |
| 10       | 1 min                          |
| 11       | 30 seconds                     |

[1] Default value.

#### 8.3.2 Clock output

A programmable square wave is available at pin CLKOUT. Operation is controlled by the COF control bits in register CLKOUT\_ctl. Frequencies of 32.768 kHz (default) down to 1 Hz can be generated for use as a system clock, microcontroller clock, input to a charge pump, or for calibration of the oscillator.

CLKOUT is an open-drain output and enabled at power-on. When disabled, the output is high-impedance.

The duty cycle of the selected clock is not controlled, however, due to the nature of the clock generation, all but the 32.768 kHz frequencies will be 50 : 50.

**Table 10. CLKOUT frequency selection**

| COF[2:0] | CLKOUT frequency (Hz) | Typical duty cycle <sup>[1]</sup> |
|----------|-----------------------|-----------------------------------|
| 000      | 32768                 | 60 : 40 to 40 : 60                |
| 001      | 16384                 | 50 : 50                           |
| 010      | 8192                  | 50 : 50                           |
| 011      | 4096                  | 50 : 50                           |
| 100      | 2048                  | 50 : 50                           |
| 101      | 1024                  | 50 : 50                           |
| 110      | 1                     | 50 : 50                           |
| 111      | CLKOUT = high-Z       | -                                 |

[1] Duty cycle definition: % HIGH-level time : % LOW-level time.

## 8.4 Register Aging\_offset

**Table 11. Aging\_offset - crystal aging offset register (address 19h) bit description**

| Bit    | Symbol  | Value                        | Description        |
|--------|---------|------------------------------|--------------------|
| 7 to 4 | -       | -                            | unused             |
| 3 to 0 | AO[3:0] | see <a href="#">Table 12</a> | aging offset value |

### 8.4.1 Crystal aging correction

The PCF2129A has an aging offset register Aging\_offset to correct the crystal aging effects<sup>2</sup>.

The accuracy of the frequency of a quartz crystal depends on the aging. Crystal suppliers usually specify the first year aging (typically  $\pm 1$  ppm, maximum  $\pm 3$  ppm) and/or the 10 years aging (typically  $\pm 5$  ppm). The aging offset adds an offset, positive or negative, in the temperature compensation circuits which allows to correct the aging effect.

The change in ppm per AO[3:0] value is different at different temperatures. At 25 °C, the aging offset bits allow a frequency correction of typically 1 ppm per AO[3:0] value, from -7 ppm to +8 ppm.

**Table 12. Frequency correction at 25 °C, typical**

| AO[3:0] |        | ppm                   |
|---------|--------|-----------------------|
| Decimal | Binary |                       |
| 0       | 0000   | +8                    |
| 1       | 0001   | +7                    |
| 2       | 0010   | +6                    |
| 3       | 0011   | +5                    |
| 4       | 0100   | +4                    |
| 5       | 0101   | +3                    |
| 6       | 0110   | +2                    |
| 7       | 0111   | +1                    |
| 8       | 1000   | <a href="#">[1]</a> 0 |
| 9       | 1001   | -1                    |
| 10      | 1010   | -2                    |
| 11      | 1011   | -3                    |
| 12      | 1100   | -4                    |
| 13      | 1101   | -5                    |
| 14      | 1110   | -6                    |
| 15      | 1111   | -7                    |

[1] Default value.

2. For further information please refer to the application note [Ref. 3 "AN10857"](#).

## 8.5 Power management functions

The PCF2129A has two power supply pins and one power output pin:

- $V_{DD}$  - the main power supply input pin
- $V_{BAT}$  - the battery backup input pin
- BBS - battery backed output voltage pin (equal to the internal power supply)

The PCF2129A has two power management functions implemented:

- Battery switch-over function
- Battery low detection function

The power management functions are controlled by the control bits PWRMNG[2:0] in register Control\_3:

**Table 13. Power management control bit description**

| PWRMNG[2:0] | Function  |
|-------------|---|
| 000         | <a href="#">[1]</a> battery switch-over function is enabled in standard mode;<br>battery low detection function is enabled                      |
| 001         | battery switch-over function is enabled in standard mode;<br>battery low detection function is disabled   |
| 010         | battery switch-over function is enabled in standard mode;<br>battery low detection function is disabled   |
| 011         | battery switch-over function is enabled in direct switching mode;<br>battery low detection function is enabled                                  |
| 100         | battery switch-over function is enabled in direct switching mode;<br>battery low detection function is disabled                                 |
| 101         | battery switch-over function is enabled in direct switching mode;<br>battery low detection function is disabled                                 |
| 111         | <a href="#">[2]</a> battery switch-over function is disabled, only one power supply ( $V_{DD}$ );<br>battery low detection function is disabled |

[1] Default value.

[2] When the battery switch-over function is disabled, the PCF2129A works only with the power supply  $V_{DD}$ ;  $V_{BAT}$  must be put to ground and the battery low detection function is disabled.

### 8.5.1 Battery switch-over function

The PCF2129A has a backup battery switch-over circuit which monitors the main power supply  $V_{DD}$  and automatically switches to the backup battery when a power failure condition is detected.

One of two operation modes can be selected:

- **Standard mode:** the power failure condition happens when:  
 $V_{DD} < V_{BAT}$  AND  $V_{DD} < V_{th(sw)bat}$
- **Direct switching mode:** the power failure condition happens when  $V_{DD} < V_{BAT}$ .  
Direct switching from  $V_{DD}$  to  $V_{BAT}$  without requiring  $V_{DD}$  to drop below  $V_{th(sw)bat}$

$V_{th(sw)bat}$  is the battery switch threshold voltage. Typical value is 2.5 V.

When a power failure condition occurs and the power supply switches to the battery the following sequence occurs:

1. The battery switch flag BF (register Control\_3) is set logic 1.
2. An interrupt is generated if the control bit BIE (register Control\_3) is enabled (see [Section 8.12.6](#)).
3. If the control bit BTSE (register Control\_3) is logic 1, the timestamp registers store the time and date when the battery switch occurred (see [Section 8.11.4](#)).
4. The battery switch flag BF is cleared via the interface; it must be cleared to clear the interrupt.

The interface is disabled in battery backup operation:

- Interface inputs are not recognized, preventing extraneous data being written to the device
- Interface outputs are high-impedance

**8.5.1.1 Standard mode**

If  $V_{DD} > V_{BAT}$  OR  $V_{DD} > V_{th(sw)bat}$  the internal power supply is  $V_{DD}$ .

If  $V_{DD} < V_{BAT}$  AND  $V_{DD} < V_{th(sw)bat}$  the internal power supply is  $V_{BAT}$ .

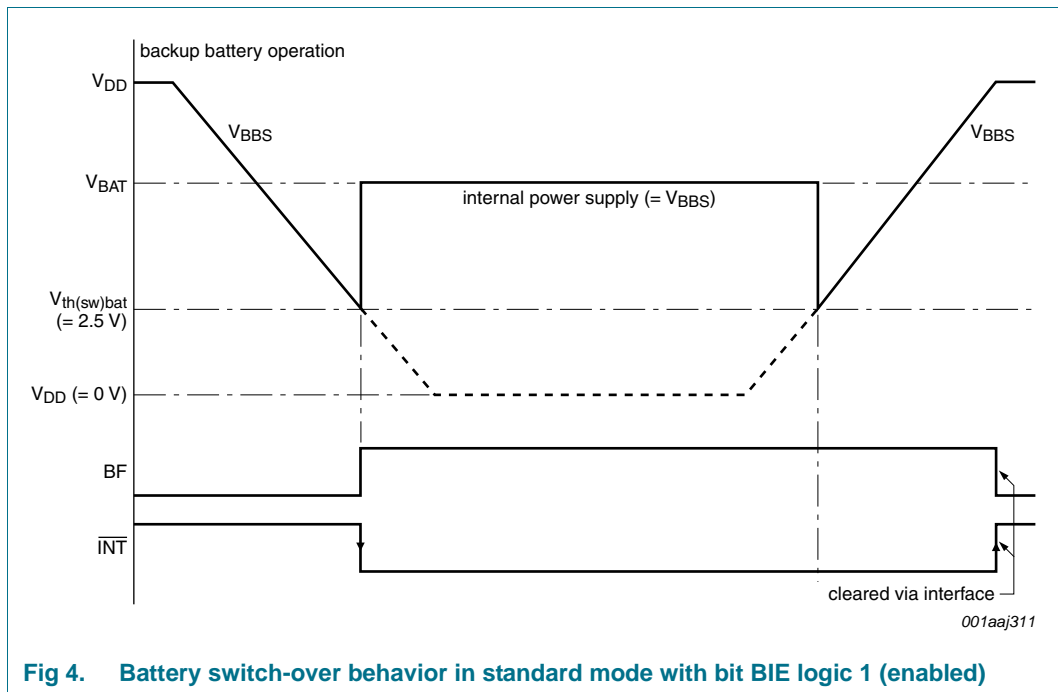

**Fig 4. Battery switch-over behavior in standard mode with bit BIE logic 1 (enabled)**

**8.5.1.2 Direct switching mode**

If  $V_{DD} > V_{BAT}$  the internal power supply is  $V_{DD}$ .

If  $V_{DD} < V_{BAT}$  the internal power supply is  $V_{BAT}$ .

The direct switching mode is useful in systems where  $V_{DD}$  is higher than  $V_{BAT}$  at all times. The direct switching mode is not recommended if the  $V_{DD}$  and  $V_{BAT}$  values are similar (e.g.  $V_{DD} = 3.3\text{ V}$ ,  $V_{BAT} \geq 3.0\text{ V}$ ). In direct switching mode the power consumption is reduced compared to the standard mode because the monitoring of  $V_{DD}$  and  $V_{th(sw)bat}$  is not performed.

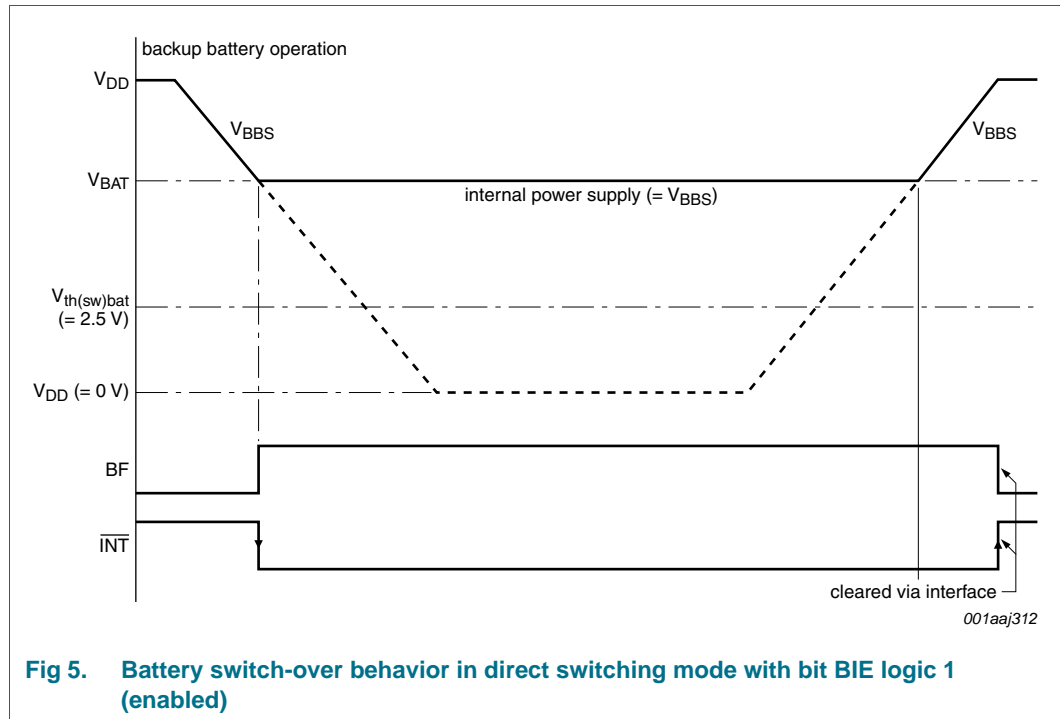

**8.5.1.3 Battery switch-over disabled: only one power supply ( $V_{DD}$ )**

When the battery switch-over function is disabled:

- The power supply is applied on the  $V_{DD}$  pin
- The  $V_{BAT}$  pin must be connected to ground
- The internal power supply, available at the output pin BBS, is equal to  $V_{DD}$
- The battery flag (BF) is always logic 0

**8.5.1.4 Battery switch-over architecture**

The architecture of the battery switch-over circuit is shown in [Figure 6](#).



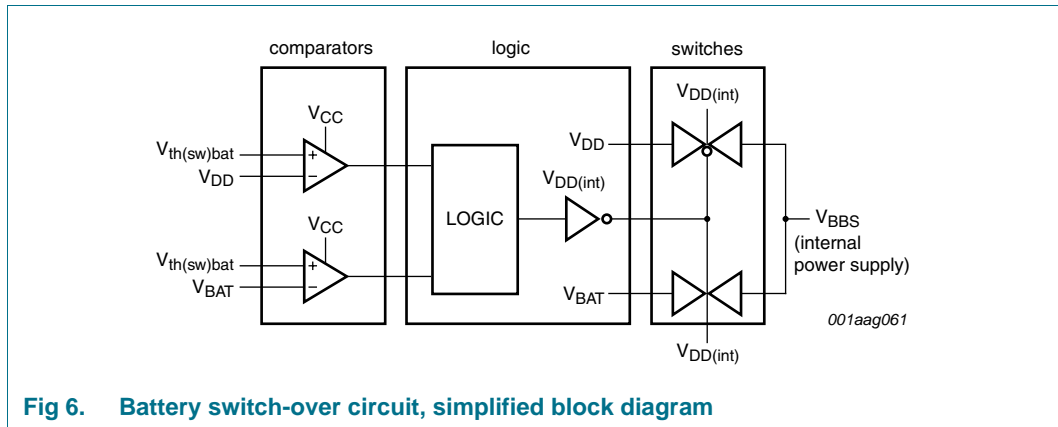

Fig 6. Battery switch-over circuit, simplified block diagram

The internal power supply (available on pin BBS) is equal to  $V_{DD}$  or  $V_{BAT}$ . It has to be assured that there are decoupling capacitors on the pins  $V_{DD}$ ,  $V_{BAT}$ , and BBS.

### 8.5.2 Battery backup supply

The  $V_{BBS}$  voltage on the output pin BBS is equal to the internal power supply and depends on the selected battery switch-over function mode:

Table 14. Output pin BBS

| Battery switch-over function mode | Conditions  | $V_{BBS}$ equals |
|-----------------------------------|---|------------------|
| standard                          | $V_{DD} > V_{BAT}$ OR $V_{DD} > V_{th(sw)bat}$              | $V_{DD}$         |
|                                   | $V_{DD} < V_{BAT}$ AND $V_{DD} < V_{th(sw)bat}$             | $V_{BAT}$        |
| direct switching                  | $V_{DD} > V_{BAT}$  | $V_{DD}$         |
|                                   | $V_{DD} < V_{BAT}$  | $V_{BAT}$        |
| disabled                          | only $V_{DD}$ available,<br>$V_{BAT}$ must be put to ground | $V_{DD}$         |

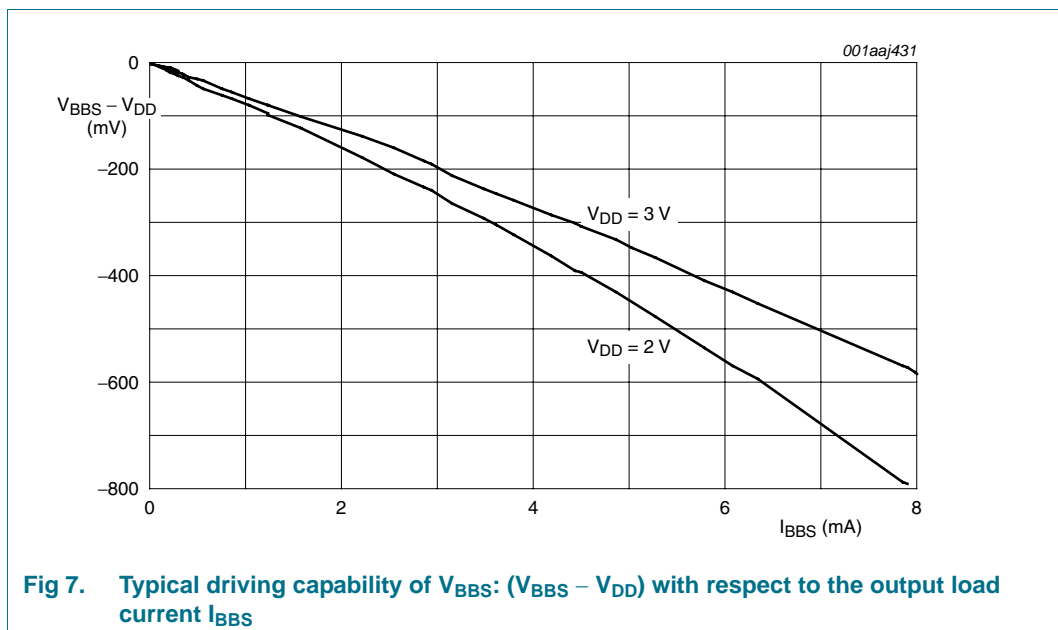

Fig 7. Typical driving capability of  $V_{BBS}$ :  $(V_{BBS} - V_{DD})$  with respect to the output load current  $I_{BBS}$

The output pin BBS can be used as a supply for battery backup devices such as SRAM (see [Ref. 3 "AN10857"](#)). For this case, [Figure 7](#) shows the typical driving capability when  $V_{BBS}$  is driven from  $V_{DD}$ .

### 8.5.3 Battery low detection function

The PCF2129A has a battery low detection circuit which monitors the status of the battery  $V_{BAT}$ .

When  $V_{BAT}$  drops below the threshold value  $V_{th(bat)low}$  (typically 2.5 V) the BLF flag (register Control\_3) is set to indicate that the battery is low and that it must be replaced. A low battery will not ensure data integrity during periods of backup battery operation. Monitoring of the battery voltage also occurs during battery operation.

When  $V_{BAT}$  drops below the threshold value  $V_{th(bat)low}$ , the following sequence occurs (see [Figure 8](#)):

1. The battery low flag BLF is set logic 1.
2. An interrupt is generated if the control bit BLIE (register Control\_3) is enabled (see [Section 8.12.7](#)).
3. The flag BLF remains logic 1 until the battery is replaced. BLF cannot be cleared using the interface. It is cleared automatically by the battery low detection circuit when the battery is replaced.

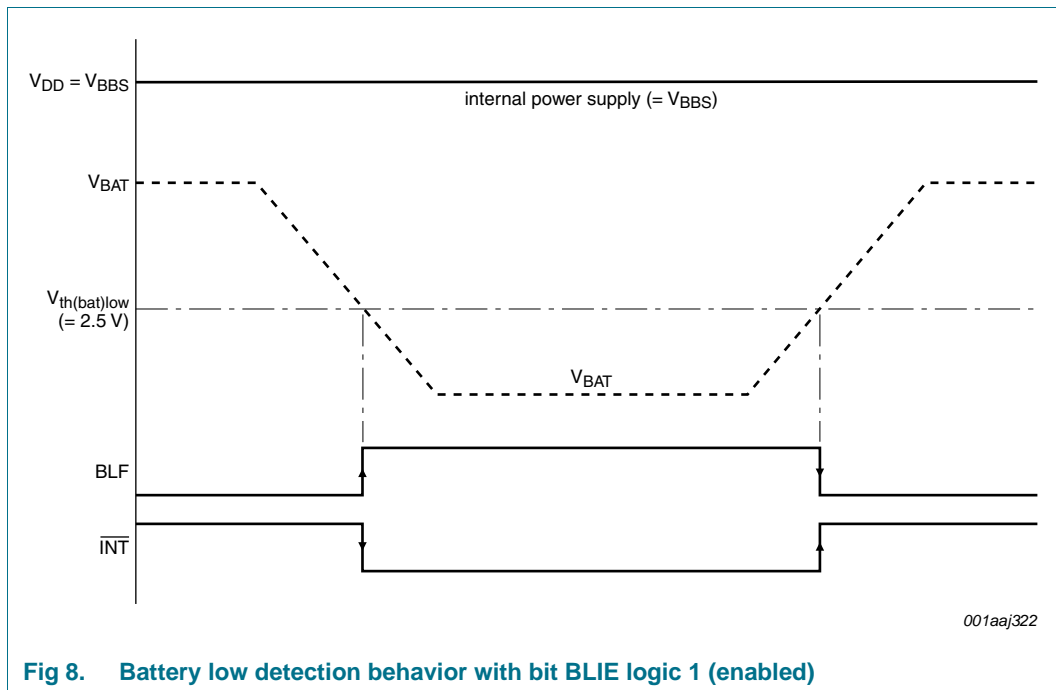

### 8.6 Oscillator stop detection function

The PCF2129A has an on-chip oscillator detection circuit which monitors the status of the oscillation: whenever the oscillation stops, a reset occurs and the oscillator stop flag OSF (in register Seconds) is set logic 1.

- **Power-on:**
  - a. The oscillator is not running, the chip is in reset (OSF is logic 1).
  - b. When the oscillator starts running and is stable after power-on, the chip exits from reset.
  - c. The flag OSF is still logic 1 and can be cleared (OSF set logic 0) via the interface.
- **Power supply failure:**
  - a. When the power supply of the chip ( $V_{DD}$  or  $V_{BAT}$ ) drops below a certain value ( $V_{low}$ ), typically 1.2 V, the oscillator stops running and a reset occurs.
  - b. When the power supply returns to normal operation, the oscillator starts running again, the chip exits from reset.
  - c. The flag OSF is still logic 1 and can be cleared (OSF set logic 0) via the interface.

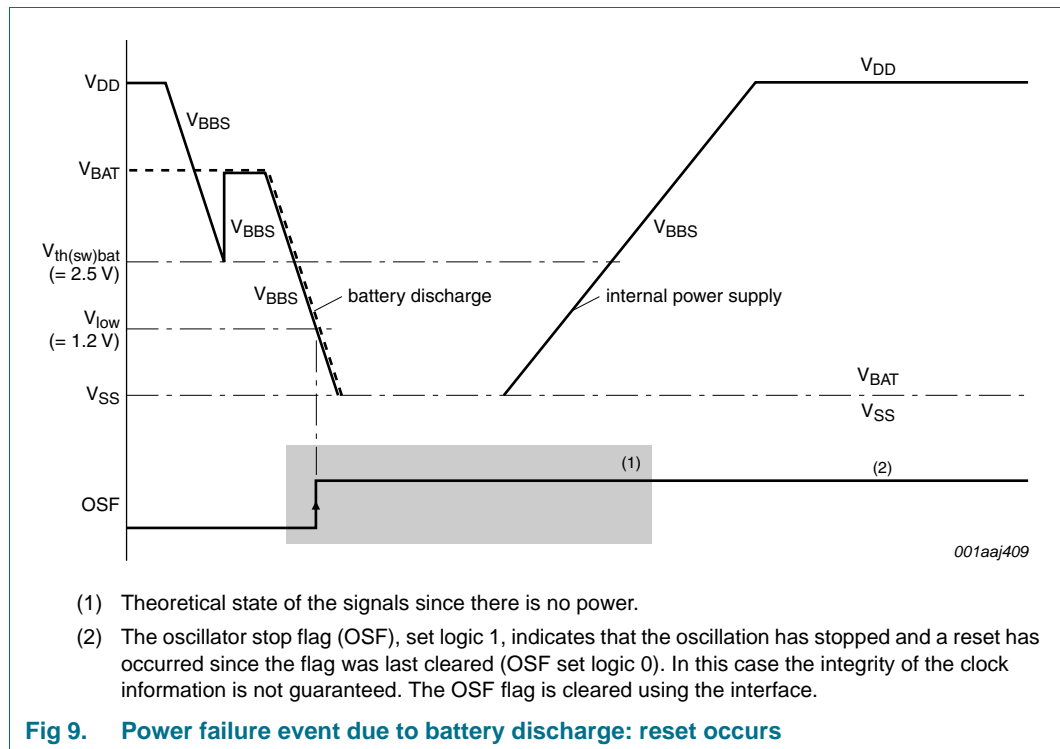

### 8.7 Reset function

The PCF2129A has a Power-On Reset (POR) and a Power-On Reset Override (PORO) function implemented.

#### 8.7.1 Power-On Reset (POR)

The POR is active whenever the oscillator is stopped. The oscillator is also considered to be stopped during the time between power-on and stable crystal resonance (see [Figure 10](#)). This time may be in the range of 200 ms to 2 s depending on temperature and supply voltage. Whenever an internal reset occurs, the oscillator stop flag is set (OSF set logic 1).

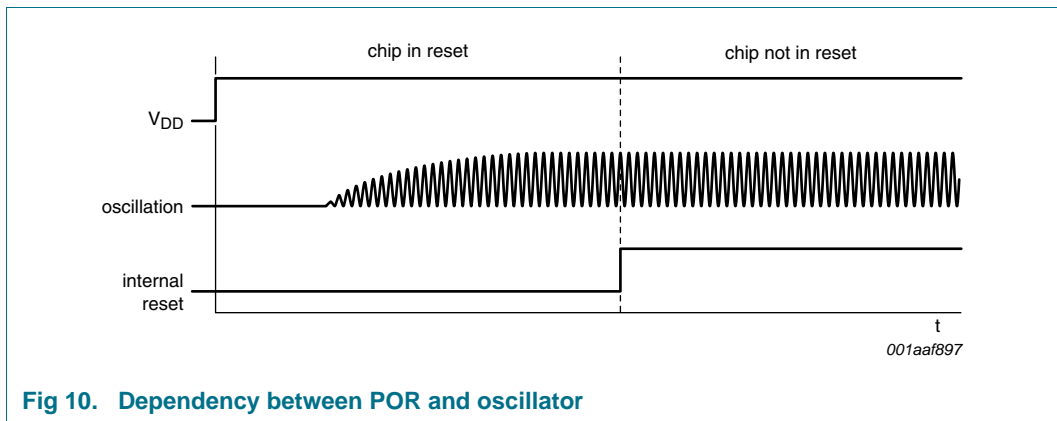

Fig 10. Dependency between POR and oscillator

After POR, the following mode is entered:

- 32.768 kHz CLKOUT active
- Power-On Reset Override (PORO) available to be set
- 24 hour mode is selected
- Battery switch-over is enabled
- Battery low detection is enabled

The register values after power-on are shown in [Table 4](#).

#### 8.7.2 Power-On Reset Override (PORO)

The POR duration is directly related to the crystal oscillator start-up time. Due to the long start-up times experienced by these types of circuits, a mechanism has been built in to disable the POR and hence speed up on-board test of the device.

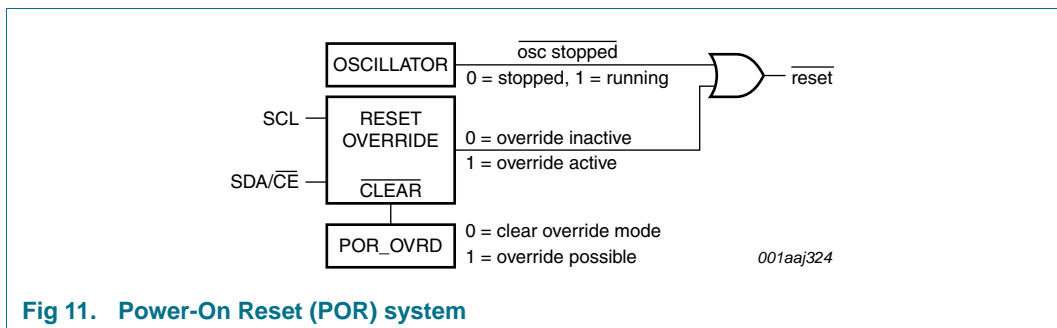
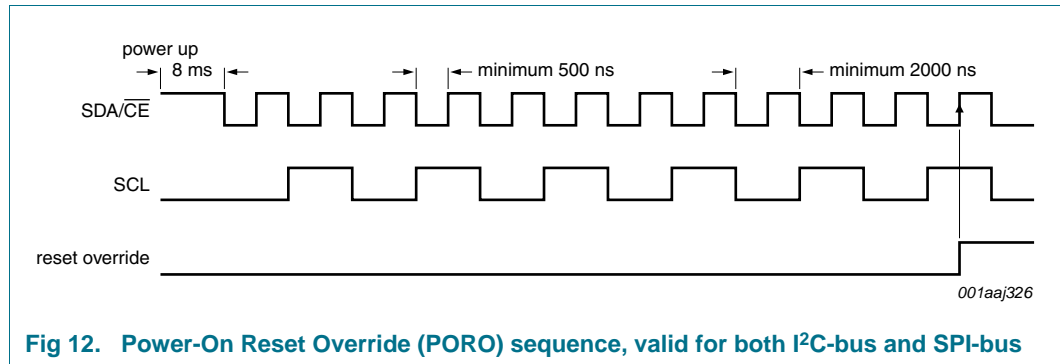

Fig 11. Power-On Reset (POR) system

The setting of the PORO mode requires that POR\_OVRD in register Control\_1 is set logic 1 and that the signals at the interface pins SDA/CE and SCL are toggled as illustrated in [Figure 12](#). All timings shown are required minimums.



**Fig 12. Power-On Reset Override (PORO) sequence, valid for both I<sup>2</sup>C-bus and SPI-bus**

Once the override mode is entered, the device is immediately released from the reset state and the set-up operation can commence.

The PORO mode is cleared by writing logic 0 to POR\_OVRD. POR\_OVRD must be logic 1 before a re-entry into the override mode is possible. Setting POR\_OVRD logic 0 during normal operation has no effect except to prevent accidental entry into the PORO mode.

## 8.8 Time and date function

The majority of this registers are coded in the Binary Coded Decimal (BCD) format.

### 8.8.1 Register Seconds

**Table 15. Seconds - seconds and clock integrity register (address 03h) bit description**

| Bit    | Symbol  | Value            | Place value | Description   |
|--------|---------|------------------|-------------|---|
| 7      | OSF     | 0                | -           | clock integrity is guaranteed   |
|        |         | 1 <sup>[1]</sup> | -           | clock integrity is not guaranteed:<br>oscillator has stopped and chip reset<br>has occurred since flag was last cleared |
| 6 to 4 | SECONDS | 0 to 5           | ten's place | actual seconds coded in BCD format  |
| 3 to 0 |         | 0 to 9           | unit place  |   |

[1] Start-up value.

**Table 16. Seconds coded in BCD format**

| Seconds value in decimal | Upper-digit (ten's place) |       |       | Digit (unit place) |       |       |       |
|--------------------------|---------------------------|-------|-------|--------------------|-------|-------|-------|
|                          | Bit 6                     | Bit 5 | Bit 4 | Bit 3              | Bit 2 | Bit 1 | Bit 0 |
| 00                       | 0                         | 0     | 0     | 0                  | 0     | 0     | 0     |
| 01                       | 0                         | 0     | 0     | 0                  | 0     | 0     | 1     |
| 02                       | 0                         | 0     | 0     | 0                  | 0     | 1     | 0     |
| :                        | :                         | :     | :     | :                  | :     | :     | :     |
| 09                       | 0                         | 0     | 0     | 1                  | 0     | 0     | 1     |
| 10                       | 0                         | 0     | 1     | 0                  | 0     | 0     | 0     |
| :                        | :                         | :     | :     | :                  | :     | :     | :     |
| 58                       | 1                         | 0     | 1     | 1                  | 0     | 0     | 0     |
| 59                       | 1                         | 0     | 1     | 1                  | 0     | 0     | 1     |

### 8.8.2 Register Minutes

**Table 17. Minutes - minutes register (address 04h) bit description**

| Bit    | Symbol  | Value  | Place value | Description                        |
|--------|---------|--------|-------------|------------------------------------|
| 7      | -       | -      | -           | unused                             |
| 6 to 4 | MINUTES | 0 to 5 | ten's place | actual minutes coded in BCD format |
| 3 to 0 |         | 0 to 9 | unit place  |                                    |

### 8.8.3 Register Hours

Table 18. Hours - hours register (address 05h) bit description

| Bit                               | Symbol | Value  | Place value | Description   |
|-----------------------------------|--------|--------|-------------|---|
| 7 to 6                            | -      | -      | -           | unused  |
| <b>12 hour mode<sup>[1]</sup></b> |        |        |             |   |
| 5                                 | AMPM   | 0      | -           | indicates AM  |
|                                   |        | 1      | -           | indicates PM  |
| 4                                 | HOURS  | 0 to 1 | ten's place | actual hours coded in BCD format when in 12 hour mode |
| 3 to 0                            |        | 0 to 9 | unit place  |   |
| <b>24 hour mode<sup>[1]</sup></b> |        |        |             |   |
| 5 to 4                            | HOURS  | 0 to 2 | ten's place | actual hours coded in BCD format when in 24 hour mode |
| 3 to 0                            |        | 0 to 9 | unit place  |   |

[1] Hour mode is set by the bit 12\_24 in register Control\_1.

### 8.8.4 Register Days

Table 19. Days - days register (address 06h) bit description

| Bit    | Symbol              | Value  | Place value | Description                    |
|--------|---------------------|--------|-------------|--------------------------------|
| 7 to 6 | -                   | -      | -           | unused                         |
| 5 to 4 | DAYS <sup>[1]</sup> | 0 to 3 | ten's place | actual day coded in BCD format |
| 3 to 0 |                     | 0 to 9 | unit place  |                                |

[1] The RTC compensates for leap years by adding a 29<sup>th</sup> day to February if the year counter contains a value which is exactly divisible by 4, including the year 00.

### 8.8.5 Register Weekdays

Table 20. Weekdays - weekdays register (address 07h) bit description

| Bit    | Symbol   | Value  | Description  |
|--------|----------|--------|--|
| 7 to 3 | -        | -      | unused   |
| 2 to 0 | WEEKDAYS | 0 to 6 | actual weekday value, see <a href="#">Table 21</a> |

Although the association of the weekdays counter to the actual weekday is arbitrary, the PCF2129A will assume Sunday is 000 and Monday is 001 for the purposes of determining the increment for calendar weeks.

Table 21. Weekday assignments

| Day <sup>[1]</sup> | Bit |   |   |
|--------------------|-----|---|---|
|                    | 2   | 1 | 0 |
| Sunday             | 0   | 0 | 0 |
| Monday             | 0   | 0 | 1 |
| Tuesday            | 0   | 1 | 0 |
| Wednesday          | 0   | 1 | 1 |
| Thursday           | 1   | 0 | 0 |
| Friday             | 1   | 0 | 1 |
| Saturday           | 1   | 1 | 0 |

[1] These bits may be re-assigned by the user.

### 8.8.6 Register Months

**Table 22. Months - months register (address 08h) bit description**

| Bit    | Symbol | Value  | Place value | Description  |
|--------|--------|--------|-------------|--|
| 7 to 5 | -      | -      | -           | unused   |
| 4      | MONTHS | 0 to 1 | ten's place | actual month coded in BCD format, see <a href="#">Table 23</a> |
| 3 to 0 |        | 0 to 9 | unit place  |  |

**Table 23. Month assignments in BCD format**

| Month     | Upper-digit<br>(ten's place) | Digit (unit place) |       |       |       |
|-----------|------------------------------|--------------------|-------|-------|-------|
|           | Bit 4                        | Bit 3              | Bit 2 | Bit 1 | Bit 0 |
| January   | 0                            | 0                  | 0     | 0     | 1     |
| February  | 0                            | 0                  | 0     | 1     | 0     |
| March     | 0                            | 0                  | 0     | 1     | 1     |
| April     | 0                            | 0                  | 1     | 0     | 0     |
| May       | 0                            | 0                  | 1     | 0     | 1     |
| June      | 0                            | 0                  | 1     | 1     | 0     |
| July      | 0                            | 0                  | 1     | 1     | 1     |
| August    | 0                            | 1                  | 0     | 0     | 0     |
| September | 0                            | 1                  | 0     | 0     | 1     |
| October   | 1                            | 0                  | 0     | 0     | 0     |
| November  | 1                            | 0                  | 0     | 0     | 1     |
| December  | 1                            | 0                  | 0     | 1     | 0     |

### 8.8.7 Register Years

**Table 24. Years - years register (address 09h) bit description**

| Bit    | Symbol | Value  | Place value | Description                     |
|--------|--------|--------|-------------|---------------------------------|
| 7 to 4 | YEARS  | 0 to 9 | ten's place | actual year coded in BCD format |
| 3 to 0 |        | 0 to 9 | unit place  |                                 |



8.8.8 Setting and reading the time

Figure 13 shows the data flow and data dependencies starting from the 1 Hz clock tick.

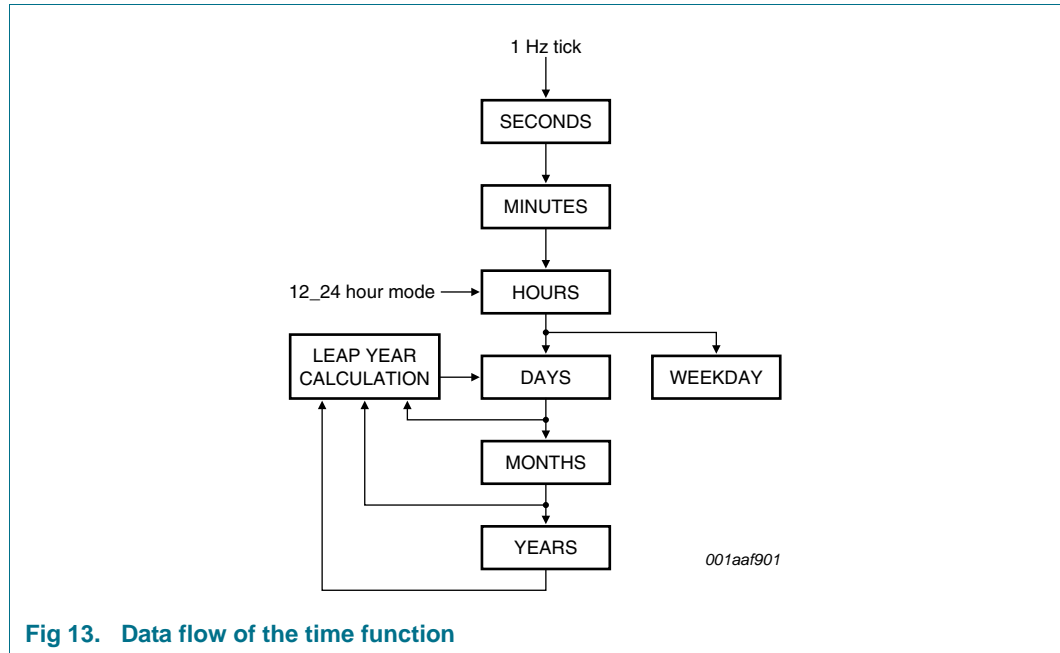

Fig 13. Data flow of the time function

During read/write operations, the time counting circuits (memory locations 03h through 09h) are blocked.

This prevents

- Faulty reading of the clock and calendar during a carry condition
- Incrementing the time registers during the read cycle

After this read/write access is completed, the time circuit is released again and any pending request to increment the time counters that occurred during the read/write access is serviced. A maximum of 1 request can be stored; therefore, all accesses must be completed within 1 second (see Figure 14).

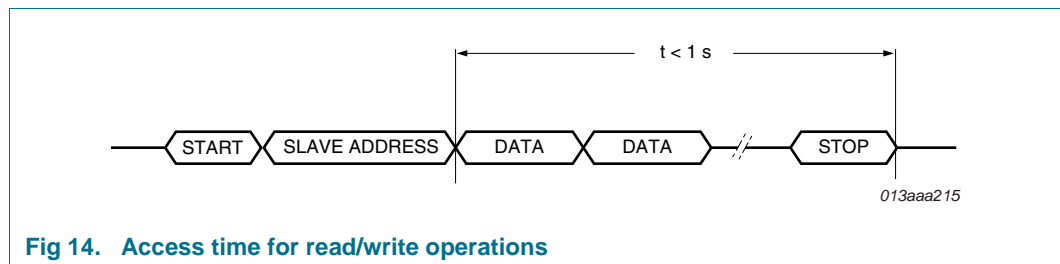

Fig 14. Access time for read/write operations

As a consequence of this method, it is very important to make a read or write access in one go, that is, setting or reading seconds through to years should be made in one single access. Failing to comply with this method could result in the time becoming corrupted.

As an example, if the time (seconds through to hours) is set in one access and then in a second access the date is set, it is possible that the time may increment between the two accesses. A similar problem exists when reading. A roll over may occur between reads thus giving the minutes from one moment and the hours from the next. Therefore it is advised to read all time and date registers in one access.

### 8.9 Alarm function

When one or more of the alarm bit fields are loaded with a valid second, minute, hour, day, or weekday and its corresponding alarm enable bit (AE\_x) is logic 0, then that information is compared with the actual second, minute, hour, day, and weekday (see [Figure 15](#)).

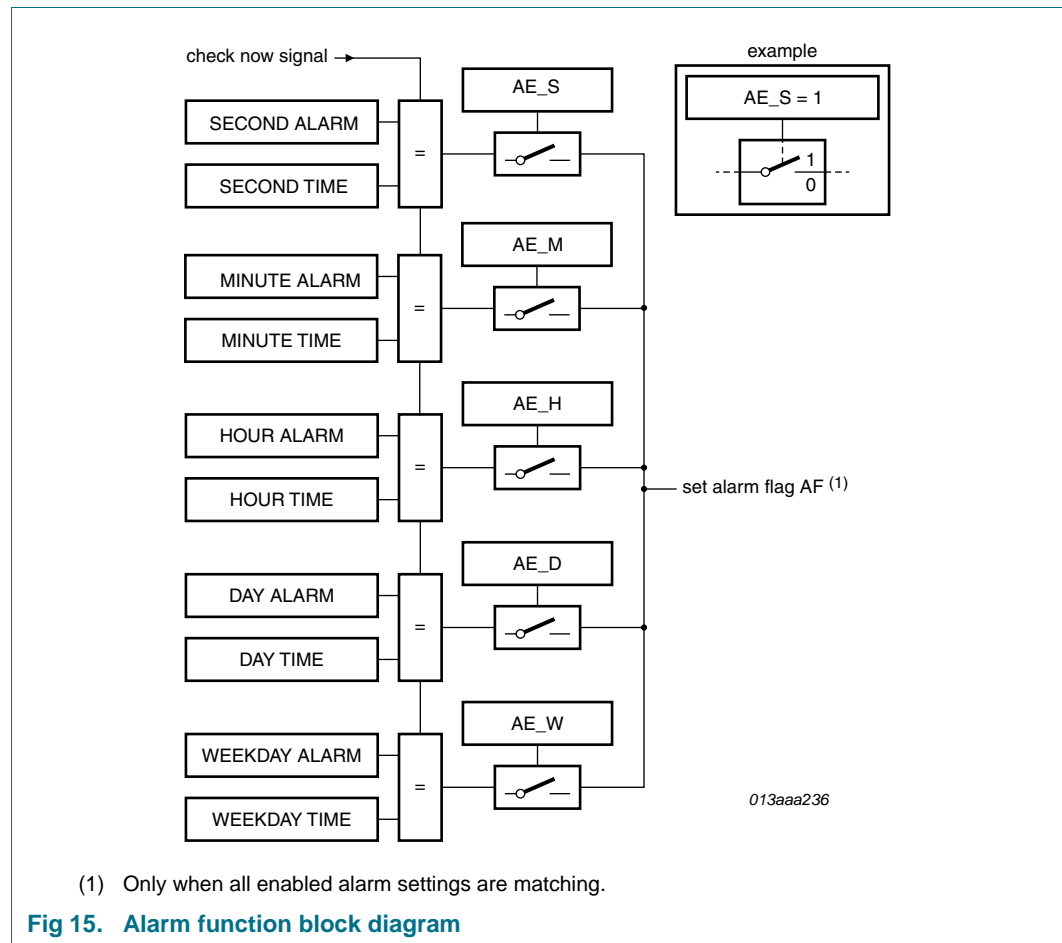

The generation of interrupts from the alarm function is described in [Section 8.12.4](#).

### 8.9.1 Register Second\_alarm

**Table 25. Second\_alarm - second alarm register (address 0Ah) bit description**

| Bit    | Symbol       | Value            | Place value | Description                                  |
|--------|--------------|------------------|-------------|--|
| 7      | AE_S         | 0                | -           | second alarm is enabled                      |
|        |              | 1 <sup>[1]</sup> | -           | second alarm is disabled                     |
| 6 to 4 | SECOND_ALARM | 0 to 5           | ten's place | second alarm information coded in BCD format |
| 3 to 0 |              | 0 to 9           | unit place  |  |

[1] Default value.

### 8.9.2 Register Minute\_alarm

**Table 26. Minute\_alarm - minute alarm register (address 0Bh) bit description**

| Bit    | Symbol       | Value            | Place value | Description                                  |
|--------|--------------|------------------|-------------|--|
| 7      | AE_M         | 0                | -           | minute alarm is enabled                      |
|        |              | 1 <sup>[1]</sup> | -           | minute alarm is disabled                     |
| 6 to 4 | MINUTE_ALARM | 0 to 5           | ten's place | minute alarm information coded in BCD format |
| 3 to 0 |              | 0 to 9           | unit place  |  |

[1] Default value.

### 8.9.3 Register Hour\_alarm

**Table 27. Hour\_alarm - hour alarm register (address 0Ch) bit description**

| Bit                               | Symbol     | Value            | Place value | Description   |
|-----------------------------------|------------|------------------|-------------|---|
| 7                                 | AE_H       | 0                | -           | hour alarm is enabled   |
|                                   |            | 1 <sup>[1]</sup> | -           | hour alarm is disabled  |
| 6                                 | -          | -                | -           | unused  |
| <b>12 hour mode<sup>[2]</sup></b> |            |                  |             |   |
| 5                                 | AMPM       | 0                | -           | indicates AM  |
|                                   |            | 1                | -           | indicates PM  |
| 4                                 | HOUR_ALARM | 0 to 1           | ten's place | hour alarm information coded in BCD format when in 12 hour mode |
| 3 to 0                            |            | 0 to 9           | unit place  |   |
| <b>24 hour mode<sup>[2]</sup></b> |            |                  |             |   |
| 5 to 4                            | HOUR_ALARM | 0 to 2           | ten's place | hour alarm information coded in BCD format when in 24 hour mode |
| 3 to 0                            |            | 0 to 9           | unit place  |   |

[1] Default value.

[2] Hour mode is set by the bit 12\_24 in register Control\_1.

### 8.9.4 Register Day\_alarm

Table 28. Day\_alarm - day rearm register (address 0Dh) bit description

| Bit    | Symbol    | Value            | Place value | Description                               |
|--------|-----------|------------------|-------------|---|
| 7      | AE_D      | 0                | -           | day alarm is enabled                      |
|        |           | 1 <sup>[1]</sup> | -           | day alarm is disabled                     |
| 6      | -         | -                | -           | unused                                    |
| 5 to 4 | DAY_ALARM | 0 to 3           | ten's place | day alarm information coded in BCD format |
| 3 to 0 |           | 0 to 9           | unit place  |   |

[1] Default value.

### 8.9.5 Register Weekday\_alarm

Table 29. Weekday\_alarm - weekday alarm register (address 0Eh) bit description

| Bit    | Symbol        | Value            | Description               |
|--------|---------------|------------------|---------------------------|
| 7      | AE_W          | 0                | weekday alarm is enabled  |
|        |               | 1 <sup>[1]</sup> | weekday alarm is disabled |
| 6 to 3 | -             | -                | unused                    |
| 2 to 0 | WEEKDAY_ALARM | 0 to 6           | weekday alarm information |

[1] Default value.

### 8.9.6 Alarm flag

When all enabled comparisons first match, the alarm flag AF (register Control\_2) is set. AF will remain set until cleared by using the interface. Once AF has been cleared it will only be set again when the time increments to match the alarm condition once more. For clearing the flags see [Section 8.10.5](#)

Alarm registers which have their alarm enable bit AE\_x at logic 1 are ignored.

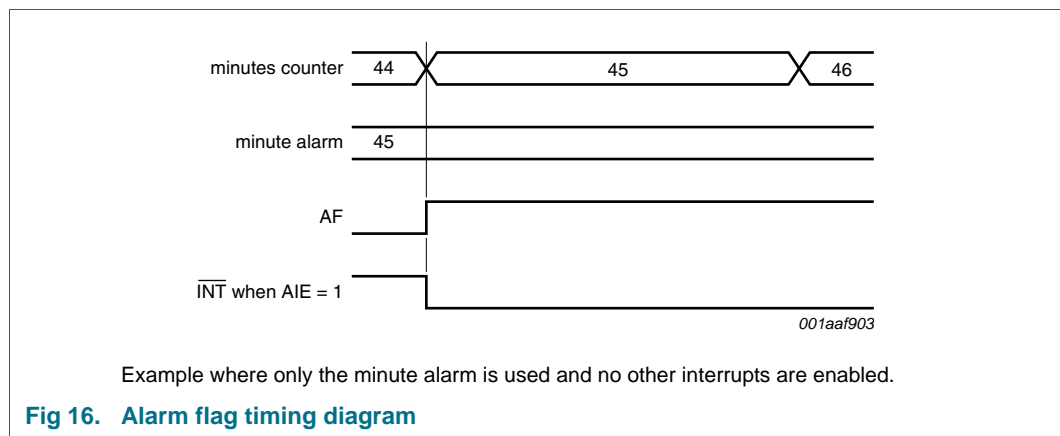

### 8.10 Timer functions

The PCF2129A has a watchdog timer function. The timer can be selected by using the control bit WD\_CD in the register Watchdg\_tim\_ctl.

The watchdog timer has four selectable source clocks. It can be used to detect a microprocessor with interrupt and reset capability which is out of control (see [Section 8.10.3](#))

To control the timer function and timer output, the registers Control\_2, Watchdg\_tim\_ctl, and Watchdg\_tim\_val are used.

#### 8.10.1 Register Watchdg\_tim\_ctl

**Table 30. Watchdg\_tim\_ctl - watchdog timer control register (address 10h) bit description**

| Bit    | Symbol  | Value             | Description   |
|--------|---------|-------------------|---|
| 7      | WD_CD   | 0 <sup>[1]</sup>  | watchdog timer disabled   |
|        |         | 1                 | watchdog timer enabled;<br>the interrupt pin $\overline{\text{INT}}$ is activated when timed out  |
| 6      | T       | 0 <sup>[2]</sup>  | unused  |
| 5      | TI_TP   | 0 <sup>[1]</sup>  | the interrupt pin $\overline{\text{INT}}$ is configured to generate a permanent active signal when MSF (register Control_2) is set        |
|        |         | 1                 | the interrupt pin $\overline{\text{INT}}$ is configured to generate a pulsed signal when MSF flag is set (see <a href="#">Figure 19</a> ) |
| 4 to 2 |         | -                 | unused  |
| 1 to 0 | TF[1:0] |                   | timer source clock for watchdog timer   |
|        |         | 00                | 4.096 kHz   |
|        |         | 01                | 64 Hz   |
|        |         | 10                | 1 Hz  |
|        |         | 11 <sup>[1]</sup> | 1/60 Hz   |

[1] Default value.

[2] When writing to the register this bit has always to be set logic 0.

#### 8.10.2 Register Watchdg\_tim\_val

**Table 31. Watchdg\_tim\_val - watchdog timer value register (address 11h) bit description**

| Bit    | Symbol                | Value    | Description   |
|--------|-----------------------|----------|---|
| 7 to 0 | WATCHDGD_TIM_VAL[7:0] | 00 to FF | countdown period in seconds:<br>$\text{CountdownPeriod} = \frac{n}{\text{SourceClockFrequency}}$ where n is the countdown value |

Table 32. Programmable watchdog timer

| TF[1:0] | Timer source clock frequency | Units | Minimum timer period (n = 1) | Units | Maximum timer period (n = 255) | Units |
|---------|------------------------------|-------|------------------------------|-------|--------------------------------|-------|
| 00      | 4.096                        | kHz   | 244                          | μs    | 62.256                         | ms    |
| 01      | 64                           | Hz    | 15.625                       | ms    | 3.984                          | s     |
| 10      | 1                            | Hz    | 1                            | s     | 255                            | s     |
| 11      | $\frac{1}{60}$               | Hz    | 60                           | s     | 15300                          | s     |

### 8.10.3 Watchdog timer function

The watchdog timer function is enabled or disabled by the WD\_CD bit of the register Watchdog\_tim\_ctl (see [Table 30](#)).

The two bits TF[1:0] in register Watchdog\_tim\_ctl determine one of the four source clock frequencies for the watchdog timer: 4.096 kHz, 64 Hz, 1 Hz, or  $\frac{1}{60}$  Hz (see [Table 32](#)).

When the watchdog timer function is enabled, the 8-bit timer in register Watchdog\_tim\_val determines the watchdog timer period.

The watchdog timer counts down from the software programmed 8-bit binary value n in register Watchdog\_tim\_val. When the counter reaches 1 the watchdog timer flag WDTF (register Control\_2) is set logic 1 and an interrupt will be generated.

The counter does not automatically reload.

When WD\_CD is logic 0 (watchdog timer disabled) and the microcontroller unit (MCU) loads a watchdog timer value n, then:

- the flag WDTF is reset
- $\overline{\text{INT}}$  is cleared
- the watchdog timer starts again

Loading the counter with 0 will:

- reset the flag WDTF
- clear  $\overline{\text{INT}}$
- stop the watchdog timer

**Remark:** WDTF is read only. A read of the register Control\_2 will automatically reset the flag WDTF.

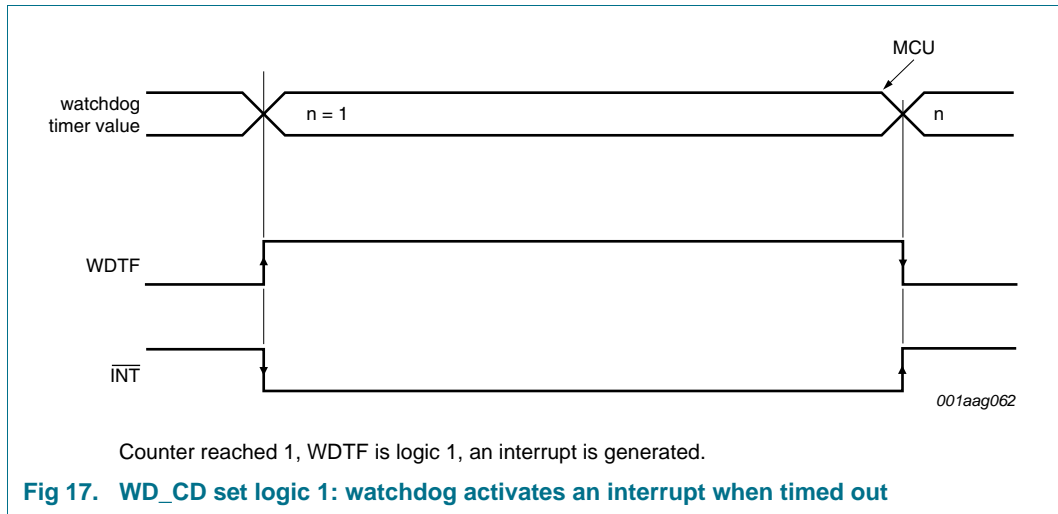

- When the watchdog timer counter reaches 1, the watchdog timer flag WDTF (register Control\_2) is set logic 1
- When a minute or second interrupt occurs, the minute/second flag MSF (register Control\_2) is set logic 1 (see [Section 8.12.1](#)).

The watchdog timer flag WDTF is read only and cannot be cleared with the interface. WDTF can be cleared by

- loading a value in register Watchdg\_tim\_val
- reading of the register Control\_2

Writing logic 0 or logic 1 to WDTF has no effect.

#### 8.10.4 Pre-defined timers: second and minute interrupt

PCF2129A has two pre-defined timers which are used to generate an interrupt either once per second or once per minute. The pulse generator for the minute or second interrupt operates from an internal 64 Hz clock. It is independent of the watchdog timer. Each of these timers can be enabled by the bits SI (second interrupt) and MI (minute interrupt) in register Control\_1.

#### 8.10.5 Clearing flags

The flags MSF, AF, and TSFx can be cleared by using the interface. To prevent one flag being overwritten while clearing another, a logic AND is performed during the write access. A flag is cleared by writing logic 0 whilst a flag is not cleared by writing logic 1. Writing logic 1 will result in the flag value remaining unchanged.

Two examples are given for clearing the flags. Clearing a flag is made by a write command:

- Bits labeled with - must be written with their previous values
- Bits labeled with T have to be written with logic 0
- WDTF is read only and has to be written with logic 0

Repeatedly re-writing these bits has no influence on the functional behavior.

**Table 33. Flag location in register Control\_2**

| Register  | Bit |      |      |    |   |   |   |   |
|-----------|-----|------|------|----|---|---|---|---|
|           | 7   | 6    | 5    | 4  | 3 | 2 | 1 | 0 |
| Control_2 | MSF | WDTF | TSF2 | AF | T | - | - | T |

**Table 34. Example values in register Control\_2**

| Register  | Bit |   |   |   |   |   |   |   |
|-----------|-----|---|---|---|---|---|---|---|
|           | 7   | 6 | 5 | 4 | 3 | 2 | 1 | 0 |
| Control_2 | 1   | 0 | 1 | 1 | 0 | 0 | 0 | 0 |

The following tables show what instruction must be sent to clear the appropriate flag.

**Table 35. Example to clear only AF (bit 4)**

| Register  | Bit |   |   |   |   |                  |                  |   |
|-----------|-----|---|---|---|---|------------------|------------------|---|
|           | 7   | 6 | 5 | 4 | 3 | 2                | 1                | 0 |
| Control_2 | 1   | 0 | 1 | 0 | 0 | 0 <sup>[1]</sup> | 0 <sup>[1]</sup> | 0 |

[1] The bits labeled as - have to be rewritten with the previous values.

**Table 36. Example to clear only MSF (bit 7)**

| Register  | Bit |   |   |   |   |                  |                  |   |
|-----------|-----|---|---|---|---|------------------|------------------|---|
|           | 7   | 6 | 5 | 4 | 3 | 2                | 1                | 0 |
| Control_2 | 0   | 0 | 1 | 1 | 0 | 0 <sup>[1]</sup> | 0 <sup>[1]</sup> | 0 |

[1] The bits labeled as - have to be rewritten with the previous values.



## 8.11 Timestamp function

The PCF2129A has an active LOW timestamp input pin  $\overline{\text{TS}}$ , internally pulled with an on-chip pull-up resistor to the internal power supply of the device. It also has a timestamp detection circuit which can detect two different events:

1. input on the pin  $\overline{\text{TS}}$  is driven to an intermediate level between the power supply and ground.
2. input on the pin  $\overline{\text{TS}}$  is driven to ground.

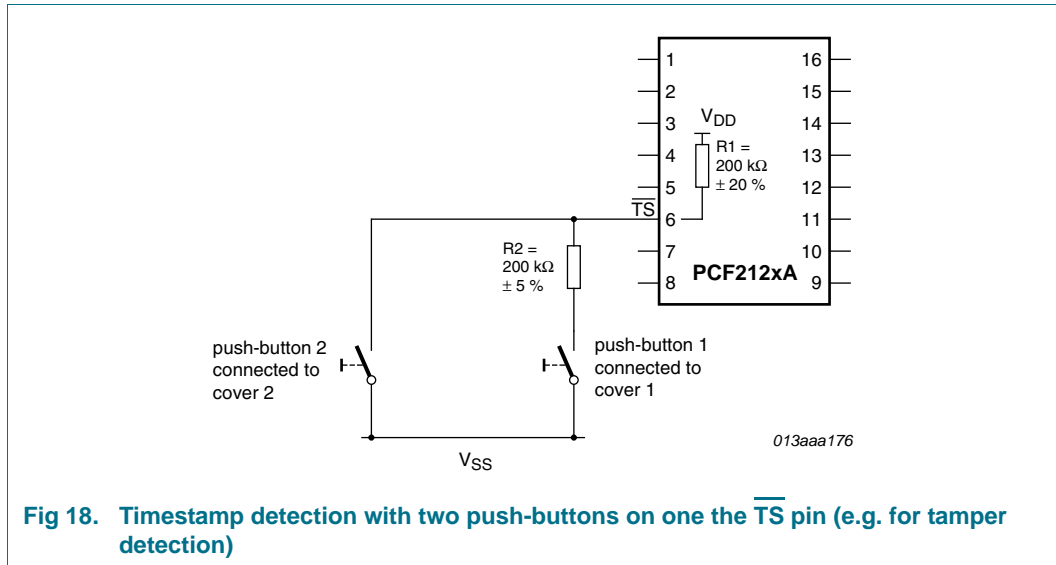

The timestamp function is enabled by default after power-on and it can be switched off by setting the control bit TSOFF (register `Timestamp_ctl`).

A most common application of the timestamp function is described in the application note [Ref. 3 "AN10857"](#).

See [Section 8.12.5](#) for a description of interrupt generation from the timestamp function.

### 8.11.1 Timestamp flag

1. When the  $\overline{\text{TS}}$  input pin is driven to an intermediate level between the power supply and ground then the following sequence occurs:
  - a. The actual date and time are stored in the timestamp registers.
  - b. The timestamp flag TSF1 (register `Control_1`) is set.
  - c. If the TSIE bit (register `Control_2`) is active, an interrupt on the  $\overline{\text{INT}}$  pin is generated.

The TSF1 flag can be cleared by using the interface. Clearing the flag will clear the interrupt. Once TSF1 is cleared it will only be set again when a new negative edge on pin  $\overline{\text{TS}}$  is detected.

2. When the  $\overline{\text{TS}}$  input pin is driven to ground the following sequence occurs:
  - a. The actual date and time are stored in the timestamp registers.
  - b. In addition to the TSF1 flag, the TSF2 flag (register `Control_3`) is set.
  - c. If the TSIE bit is active, an interrupt on the  $\overline{\text{INT}}$  pin is generated.

The TSF1 and TSF2 flags can be cleared by using the interface; clearing both flags will clear the interrupt. Once TSF2 is cleared it will only be set again when pin  $\overline{TS}$  is driven to ground once again.

### 8.11.2 Timestamp mode

The timestamp function has two different modes selected by the control bit TSM (timestamp mode) in register Timestp\_ctl:

- If TSM is logic 0 (default): in subsequent trigger events without clearing the timestamp flags, the last timestamp event is stored
- If TSM is logic 1: in subsequent trigger events without clearing the timestamp flags, the first timestamp event is stored

The timestamp function also depends on the control bit BTSE (battery switch timestamp enable) in register Control\_3, see [Section 8.11.4](#).

### 8.11.3 Timestamp registers

#### 8.11.3.1 Register Timestp\_ctl

**Table 37. Timestp\_ctl - timestamp control register (address 12h) bit description**

| Bit    | Symbol              | Value            | Description  |
|--------|---------------------|------------------|--|
| 7      | TSM                 | 0 <sup>[1]</sup> | in subsequent events without clearing the timestamp flags, the last event is stored  |
|        |                     | 1                | in subsequent events without clearing the timestamp flags, the first event is stored |
| 6      | TSOFF               | 0 <sup>[1]</sup> | timestamp function active  |
|        |                     | 1                | timestamp function disabled  |
| 5      | -                   | -                | unused   |
| 4 to 0 | 1_O_16_TIMESTP[4:0] |                  | $\frac{1}{16}$ second timestamp information coded in BCD format                      |

[1] Default value.

#### 8.11.3.2 Register Sec\_timestp

**Table 38. Sec\_timestp - second timestamp register (address 13h) bit description**

| Bit    | Symbol         | Value  | Place value | Description                                      |
|--------|----------------|--------|-------------|--|
| 7      | -              | -      | -           | unused   |
| 6 to 4 | SECOND_TIMESTP | 0 to 5 | ten's place | second timestamp information coded in BCD format |
| 3 to 0 |                | 0 to 9 | unit place  |  |

#### 8.11.3.3 Register Min\_timestp

**Table 39. Min\_timestp - minute timestamp register (address 14h) bit description**

| Bit    | Symbol         | Value  | Place value | Description                                      |
|--------|----------------|--------|-------------|--|
| 7      | -              | -      | -           | unused   |
| 6 to 4 | MINUTE_TIMESTP | 0 to 5 | ten's place | minute timestamp information coded in BCD format |
| 3 to 0 |                | 0 to 9 | unit place  |  |

### 8.11.3.4 Register Hour\_timestp

**Table 40. Hour\_timestp - hour timestamp register (address 15h) bit description**

| Bit                               | Symbol       | Value  | Place value | Description   |
|-----------------------------------|--------------|--------|-------------|---|
| 7 to 6                            | -            | -      | -           | unused  |
| <b>12 hour mode<sup>[1]</sup></b> |              |        |             |   |
| 5                                 | AMPM         | 0      | -           | indicates AM  |
|                                   |              | 1      | -           | indicates PM  |
| 4                                 | HOUR_TIMESTP | 0 to 1 | ten's place | hour timestamp information coded in BCD format when in 12 hour mode |
| 3 to 0                            |              | 0 to 9 | unit place  |   |
| <b>24 hour mode<sup>[1]</sup></b> |              |        |             |   |
| 5 to 4                            | HOUR_TIMESTP | 0 to 2 | ten's place | hour timestamp information coded in BCD format when in 24 hour mode |
| 3 to 0                            |              | 0 to 9 | unit place  |   |

[1] Hour mode is set by the bit 12\_24 in register Control\_1.

### 8.11.3.5 Register Day\_timestp

**Table 41. Day\_timestp - day timestamp register (address 16h) bit description**

| Bit    | Symbol      | Value  | Place value | Description                                   |
|--------|-------------|--------|-------------|---|
| 7 to 6 | -           | -      | -           | unused  |
| 5 to 4 | DAY_TIMESTP | 0 to 3 | ten's place | day timestamp information coded in BCD format |
| 3 to 0 |             | 0 to 9 | unit place  |   |

### 8.11.3.6 Register Mon\_timestp

**Table 42. Mon\_timestp - month timestamp register (address 17h) bit description**

| Bit    | Symbol        | Value  | Place value | Description                                     |
|--------|---------------|--------|-------------|---|
| 7 to 5 | -             | -      | -           | unused  |
| 4      | MONTH_TIMESTP | 0 to 1 | ten's place | month timestamp information coded in BCD format |
| 3 to 0 |               | 0 to 9 | unit place  |   |

### 8.11.3.7 Register Year\_timestp

**Table 43. Year\_timestp - year timestamp register (address 18h) bit description**

| Bit    | Symbol       | Value  | Place value | Description                                    |
|--------|--------------|--------|-------------|--|
| 7 to 4 | YEAR_TIMESTP | 0 to 9 | ten's place | year timestamp information coded in BCD format |
| 3 to 0 |              | 0 to 9 | unit place  |  |

#### 8.11.4 Dependency between Battery switch-over and timestamp

The timestamp function depends on the control bit BTSE in register Control\_3:

**Table 44. Battery switch-over and timestamp**

| BTSE | BF | Description  |
|------|----|--|
| 0    | -  | [1] the battery switch-over does not affect the timestamp registers  |
| 1    |    | If a battery switch-over event occurs:   |
|      | 0  | the timestamp registers store the time and date when the switch-over occurs; after this event occurred BF is set logic 1                                     |
|      | 1  | the timestamp registers are not modified; in this condition subsequent battery switch-over events or falling edges on pin $\overline{TS}$ are not registered |

[1] Default value.

### 8.12 Interrupt output, $\overline{\text{INT}}$

PCF2129A has an interrupt output pin  $\overline{\text{INT}}$  which is open-drain, active LOW. Interrupts may be sourced from different places:

- second or minute timer
- watchdog timer
- alarm
- timestamp
- battery switch-over
- battery low detection

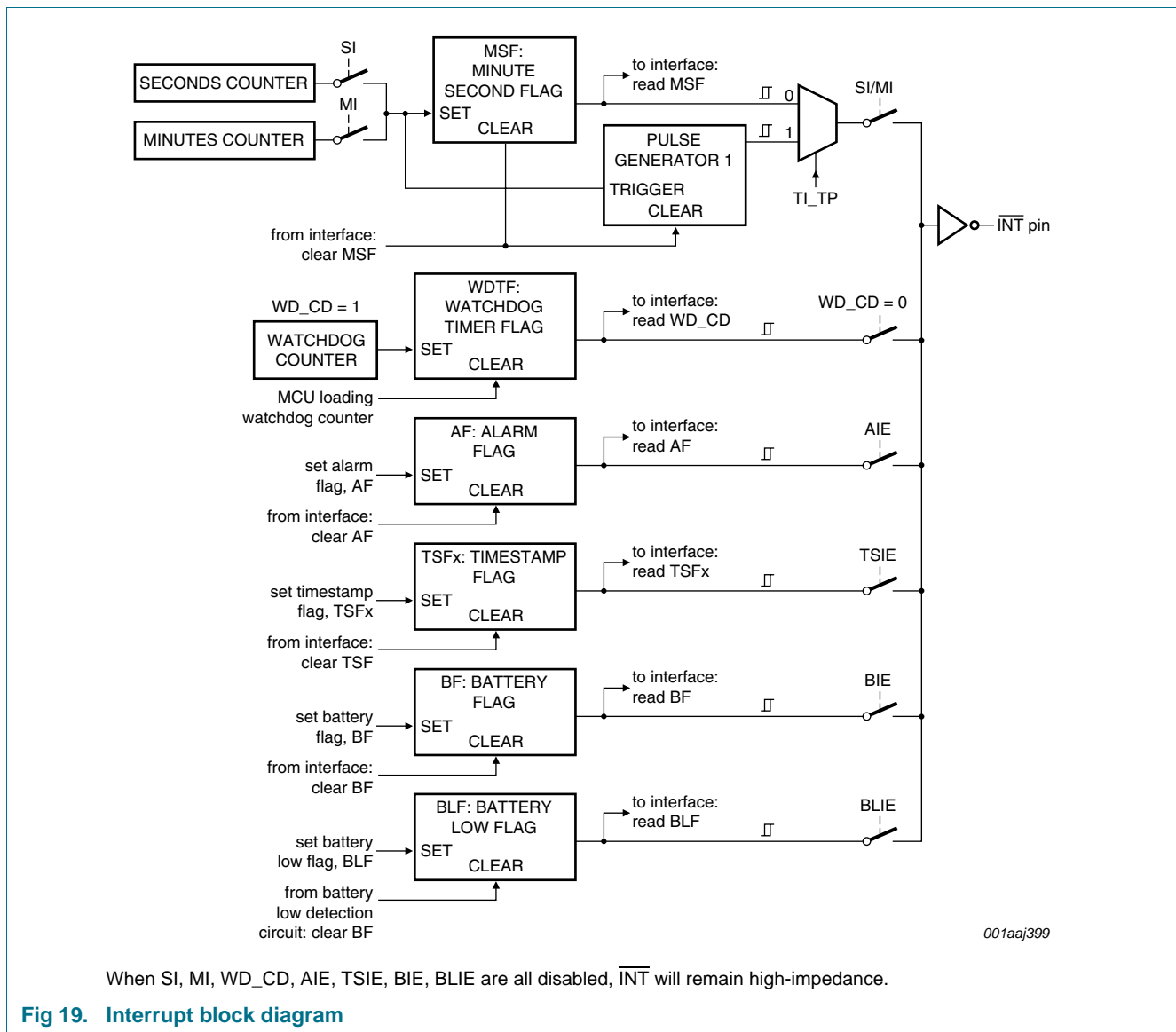

Fig 19. Interrupt block diagram

The control bit TI\_TP (register Watchdog\_tim\_ctl) is used to configure whether the interrupts generated from the second/minute timer (flag MSF in register Control\_2) are pulsed signals or a permanently active signal. All the other interrupt sources generate a permanently active interrupt signal which follows the status of the corresponding flags. When the interrupt sources are all disabled, INT remains high-impedance.

- The flags MSF, AF, TSF<sub>x</sub>, and BF can be cleared by using the interface.
- The flag WDTF is read only. How it can be cleared is explained in [Section 8.10.5](#).
- The flag BLF is read only. It is cleared automatically from the battery low detection circuit when the battery is replaced.

### 8.12.1 Minute and second interrupts

Minute and second interrupts are generated by predefined timers. The timers can be enabled independently from one another by the bits MI and SI in register Control\_1. However, a minute interrupt enabled on top of a second interrupt will not be distinguishable since it will occur at the same time.

The minute/second flag MSF (register Control\_2) is set logic 1 when either the seconds or the minutes counter increments according to the actually enabled interrupt (see [Table 45](#)). The MSF flag can be read and cleared by the interface.

**Table 45. Effect of bits MI and SI on pin INT and bit MSF**

| MI | SI | Result on INT                | Result on MSF                                  |
|----|----|------------------------------|--|
| 0  | 0  | no interrupt generated       | MSF never set                                  |
| 1  | 0  | an interrupt once per minute | MSF set when <b>minutes</b> counter increments |
| 0  | 1  | an interrupt once per second | MSF set when <b>seconds</b> counter increments |
| 1  | 1  | an interrupt once per second | MSF set when <b>seconds</b> counter increments |

When MSF is set logic 1:

- If TI\_TP is logic 1 the interrupt is generated as a pulsed signal.
- If TI\_TP is logic 0 the interrupt is permanently active signal that remains until MSF is cleared.

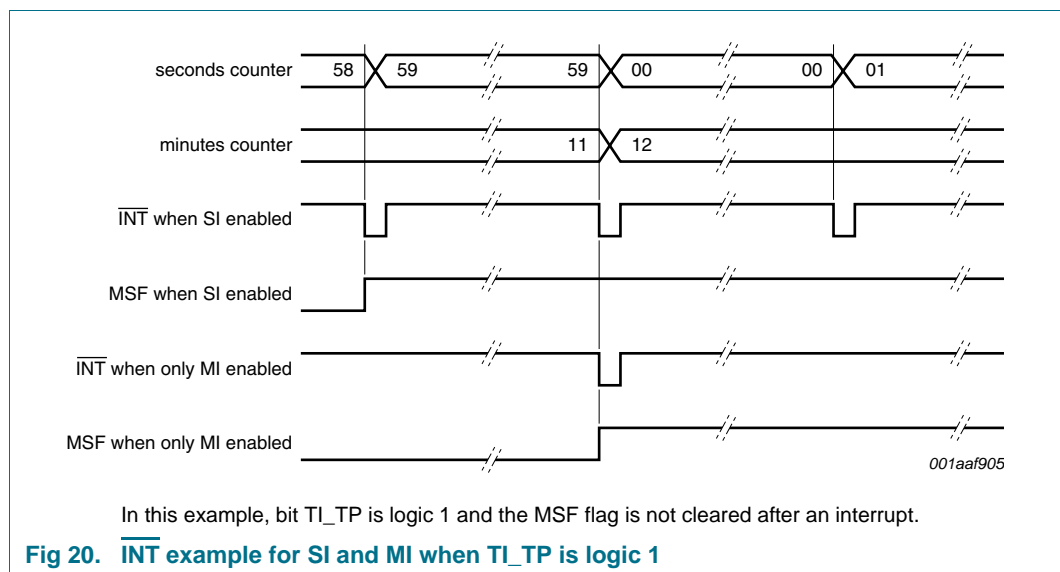

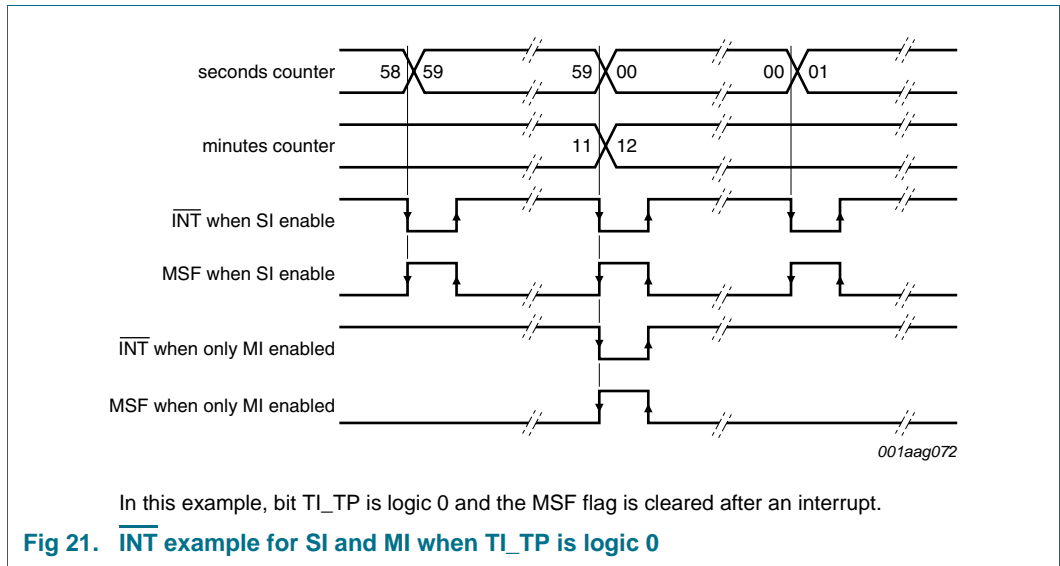

The pulse generator for the minute/second interrupt operates from an internal 64 Hz clock and generates a pulse of  $\frac{1}{64}$  seconds in duration.

### 8.12.2 $\overline{\text{INT}}$ pulse shortening

If the MSF flag (register Control\_2) is cleared before the end of the  $\overline{\text{INT}}$  pulse, then the  $\overline{\text{INT}}$  pulse is shortened. This allows the source of a system interrupt to be cleared immediately when it is serviced, i.e. the system does not have to wait for the completion of the pulse before continuing; see [Figure 22](#). Instructions for clearing the bit MSF can be found in [Section 8.10.5](#).

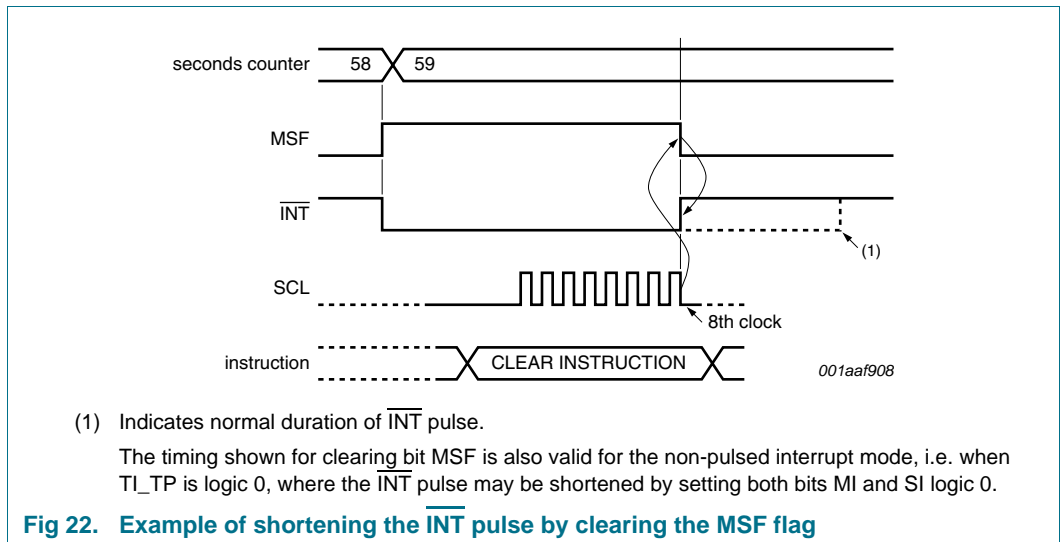

### 8.12.3 Watchdog timer interrupts

The generation of interrupts from the watchdog timer is controlled using the WD\_CD bit (register Watchdog\_tim\_ctl). The interrupt is generated as an active signal which follows the status of the watchdog timer flag WDTF (register Control\_2). No pulse generation is possible for watchdog timer interrupts.

The interrupt is cleared when the flag WDTF is reset. WDTF is a read only bit and cannot be cleared by using the interface. Instructions for clearing it can be found in [Section 8.10.5](#).

### 8.12.4 Alarm interrupts

Generation of interrupts from the alarm function is controlled via the bit AIE (register Control\_2). If AIE is enabled, the  $\overline{\text{INT}}$  pin will follow the status of bit AF (register Control\_2). Clearing AF will immediately clear  $\overline{\text{INT}}$ . No pulse generation is possible for alarm interrupts.

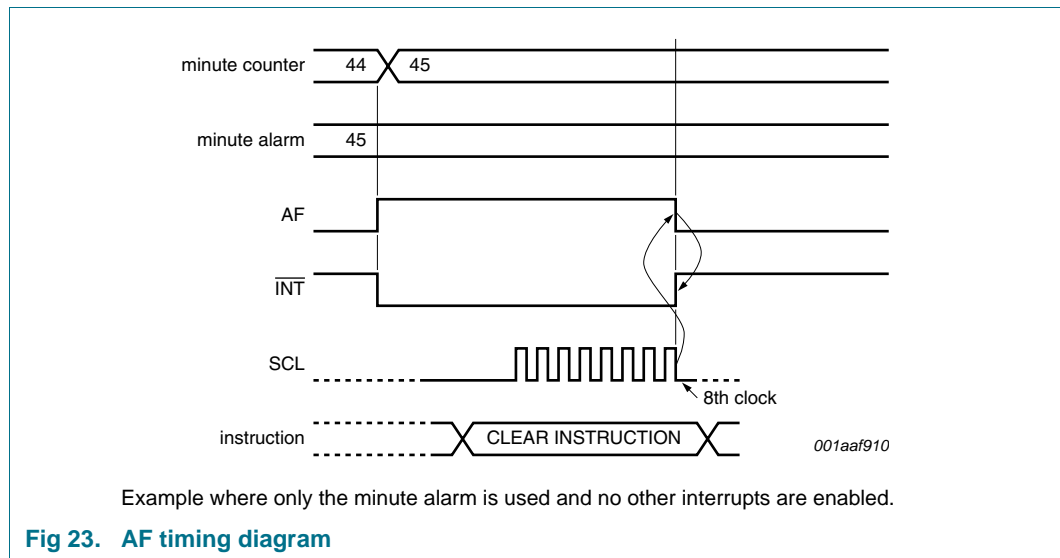

### 8.12.5 Timestamp interrupts

Interrupt generation from the timestamp function is controlled using the TSIE bit (register Control\_2). If TSIE is enabled the  $\overline{\text{INT}}$  pin follows the status of the flags TSFx. Clearing the flags TSFx immediately clears  $\overline{\text{INT}}$ . No pulse generation is possible for timestamp interrupts.

### 8.12.6 Battery switch-over interrupts

Generation of interrupts from the battery switch-over is controlled via the BIE bit (register Control\_3). If BIE is enabled, the  $\overline{\text{INT}}$  pin follows the status of bit BF (register Control\_3). Clearing BF immediately clears  $\overline{\text{INT}}$ . No pulse generation is possible for battery switch-over interrupts.

### 8.12.7 Battery low detection interrupts

Generation of interrupts from the battery low detection is controlled via the BLIE bit (register Control\_3). If BLIE is enabled the  $\overline{\text{INT}}$  pin will follow the status of bit BLF (register Control\_3). The interrupt is cleared when the battery is replaced (BLF is logic 0) or when bit BLIE is disabled (BLIE is logic 0). BLF is read only and therefore cannot be cleared via the interface.



### 8.13 External clock test mode

A test mode is available which allows on-board testing. In this mode it is possible to set up test conditions and control the operation of the RTC.

The test mode is entered by setting bit EXT\_TEST logic 1 (register Control\_1). Then pin CLKOUT becomes an input. The test mode replaces the internal clock signal (64 Hz) with the signal applied to pin CLKOUT. Every 64 positive edges applied to pin CLKOUT generate an increment of one second.

The signal applied to pin CLKOUT should have a minimum pulse width of 300 ns and a maximum period of 1000 ns. The internal clock, now sourced from CLKOUT, is divided down by a  $2^6$  divider chain called prescaler (see prescaler in [Table 46](#)). The prescaler can be set into a known state by using bit STOP. When bit STOP is logic 1, the prescaler is reset to 0. STOP must be cleared before the prescaler can operate again.

From a stop condition, the first 1 second increment will take place after 32 positive edges on pin CLKOUT. Thereafter, every 64 positive edges will cause a 1 second increment.

**Remark:** Entry into test mode is not synchronized to the internal 64 Hz clock. When entering the test mode, no assumption as to the state of the prescaler can be made.

Operating example:

1. Set EXT\_TEST test mode (register Control\_1, EXT\_TEST is logic 1).
2. Set bit STOP (register Control\_1, STOP is logic 1).
3. Set time registers to desired value.
4. Clear STOP (register Control\_1, STOP is logic 0).
5. Apply 32 clock pulses to CLKOUT.
6. Read time registers to see the first change.
7. Apply 64 clock pulses to CLKOUT.
8. Read time registers to see the second change.

Repeat 7 and 8 for additional increments.

### 8.14 STOP bit function

The function of the STOP bit is to allow for accurate starting of the time circuits. STOP will cause the upper part of the prescaler ( $F_9$  to  $F_{14}$ ) to be held in reset and thus no 1 Hz ticks are generated. The time circuits can then be set and will not increment until the STOP bit is released. STOP will not affect the CLKOUT signal but the output of the prescaler in the range of 32 Hz to 1 Hz (see [Figure 24](#)).

The lower stages of the prescaler,  $F_0$  to  $F_8$ , are not reset and because the I<sup>2</sup>C-bus and the SPI-bus are asynchronous to the crystal oscillator, the accuracy of re-starting the time circuits is between 0 and one 64 Hz cycle (0.484375 s and 0.500000 s), see [Table 46](#) and [Figure 25](#).

**Table 46. First increment of time circuits after stop release**

| Bit STOP   | Prescaler bits <sup>[1]</sup><br>$F_0$ to $F_8$ - $F_9$ to $F_{14}$ | 1 Hz tick | Time<br>hh:mm:ss | Comment   |
|--|---|-----------|------------------|---|
| <b>Clock is running normally</b>   |   |           |                  |   |
| 0  | 0100001111-010100   |           | 12:45:12         | prescaler counting normally                           |
| <b>STOP bit is activated by user. <math>F_0</math> to <math>F_8</math> are not reset and values cannot be predicted externally</b> |   |           |                  |   |
| 1  | xxxxxxxx-000000   |           | 12:45:12         | prescaler is reset; time circuits are frozen          |
| <b>New time is set by user</b>   |   |           |                  |   |
| 1  | xxxxxxxx-000000   |           | 08:00:00         | prescaler is reset; time circuits are frozen          |
| <b>STOP bit is released by user</b>  |   |           |                  |   |
| 0  | xxxxxxxx-000000   |           | 08:00:00         | prescaler is now running                              |
| 0  | xxxxxxxx-100000   |           | 08:00:00         |   |
| 0  | xxxxxxxx-100000   |           | 08:00:00         |   |
| 0  | xxxxxxxx-110000   |           | 08:00:00         |   |
| :  | :   |           | :                |   |
| 0  | 1111111111-111110   |           | 08:00:00         |   |
| 0  | 0000000000-000001   |           | 08:00:01         | 0 to 1 transition of F14 increments the time circuits |
| 0  | 1000000000-000001   |           | 08:00:01         |   |
| :  | :   |           | :                |   |
| 0  | 1111111111-111111   |           | 08:00:01         |   |
| 0  | 0000000000-000000   |           | 08:00:01         |   |
| 0  | 1000000000-000000   |           | 08:00:01         |   |
| :  | :   |           | :                |   |
| 0  | 1111111111-111110   |           | 08:00:01         |   |
| 0  | 0000000000-000001   |           | 08:00:02         | 0 to 1 transition of F14 increments the time circuits |

[1]  $F_0$  is clocked at 32.768 kHz.

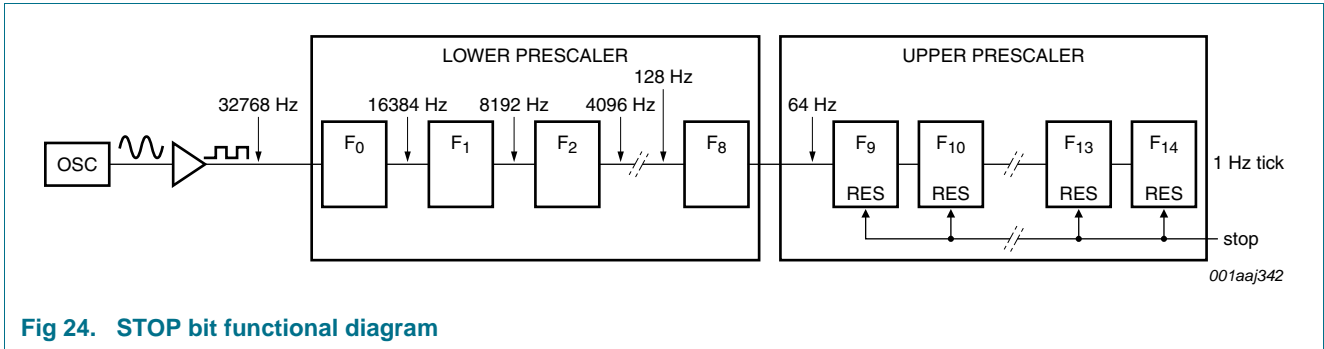

Fig 24. STOP bit functional diagram

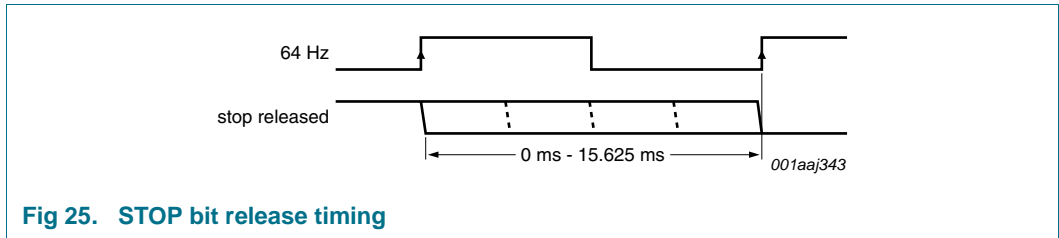

Fig 25. STOP bit release timing

## 9. Interfaces

The PCF2129A has a selectable I<sup>2</sup>C-bus or SPI-bus interface. The selection is done using the interface selection pin IFS (see [Table 47](#)).

**Table 47. Interface selection input pin IFS**

| Pin | Connection      | Bus interface        | Reference                   |
|-----|-----------------|----------------------|-----------------------------|
| IFS | V <sub>SS</sub> | SPI-bus              | <a href="#">Section 9.1</a> |
|     | BBS             | I <sup>2</sup> C-bus | <a href="#">Section 9.2</a> |

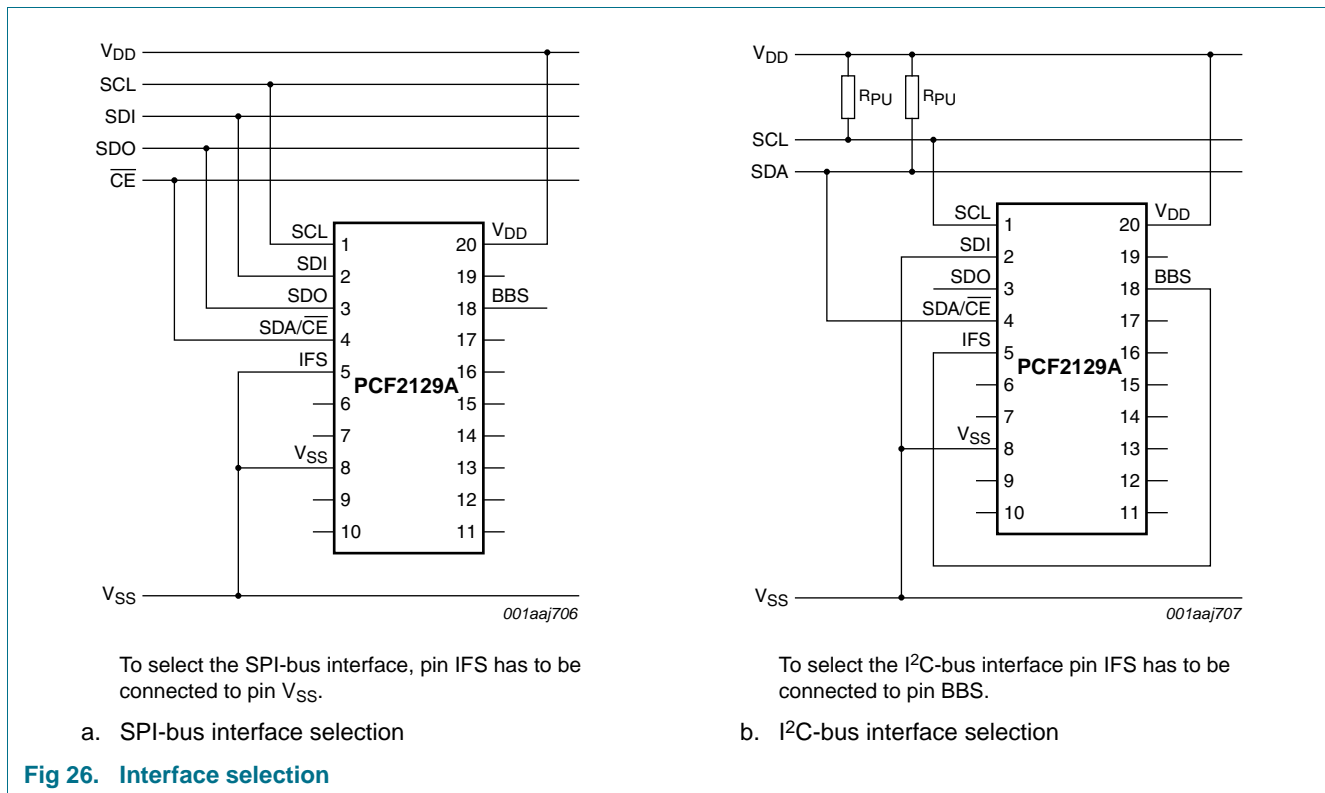

### 9.1 SPI-bus interface

Data transfer to and from the device is made via a 3 line SPI-bus (see [Table 48](#)). The data lines for input and output are split. The data input and output line can be connected together to facilitate a bidirectional data bus (see [Figure 27](#)). The SPI-bus is initialized whenever the chip enable line pin  $\overline{CE}$  is inactive.

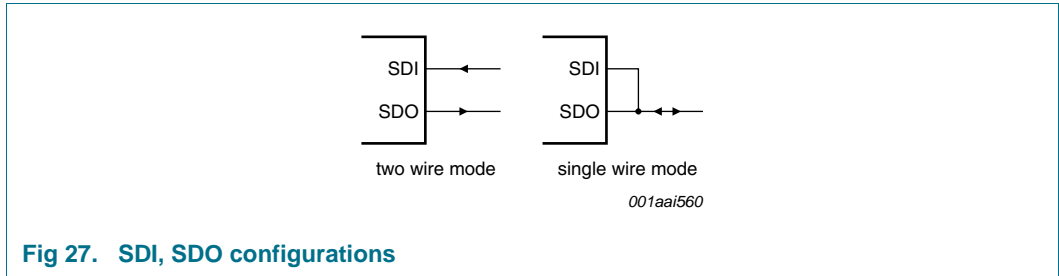

**Table 48. Serial interface**

| Symbol              | Function                      | Description  |
|---------------------|-------------------------------|--|
| $SDA/\overline{CE}$ | chip enable input; active LOW | [1] when HIGH, the interface is reset; input may be higher than $V_{DD}$   |
| SCL                 | serial clock input            | when $\overline{CE}$ is HIGH, input may float; input may be higher than $V_{DD}$   |
| SDI                 | serial data input             | when $\overline{CE}$ is HIGH, input may float; input may be higher than $V_{DD}$ ; input data is sampled on the rising edge of SCL |
| SDO                 | serial data output            | push-pull output; drives from $V_{SS}$ to $V_{BBS}$ ; output data is changed on the falling edge of SCL                            |

[1] The chip enable must not be wired permanently LOW.

#### 9.1.1 Data transmission

The chip enable signal is used to identify the transmitted data. Each data transfer is a byte, with the Most Significant Bit (MSB) sent first.

The transmission is controlled by the active LOW chip enable signal  $SDA/\overline{CE}$ . The first byte transmitted is the command byte. Subsequent bytes will be either data to be written or data to be read (see [Figure 28](#)).

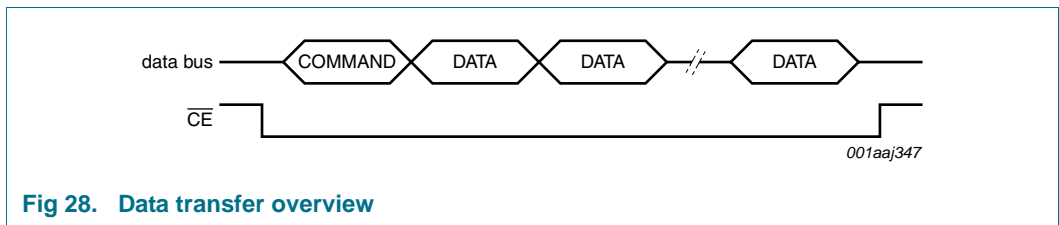

The command byte defines the address of the first register to be accessed and the read/write mode. The address counter will auto increment after every access and will reset to zero after the last valid register is accessed. The read/write bit (R/W) defines if the following bytes will be read or write information.

Table 49. Command byte definition

| Bit    | Symbol | Value      | Description  |
|--------|--------|------------|--|
| 7      | R/W    |            | data read or write selection   |
|        |        | 0          | write data   |
|        |        | 1          | read data  |
| 6 to 5 | SA     | 01         | subaddress;<br>other codes will cause the device to ignore data transfer |
| 4 to 0 | RA     | 00h to 1Dh | register address range   |

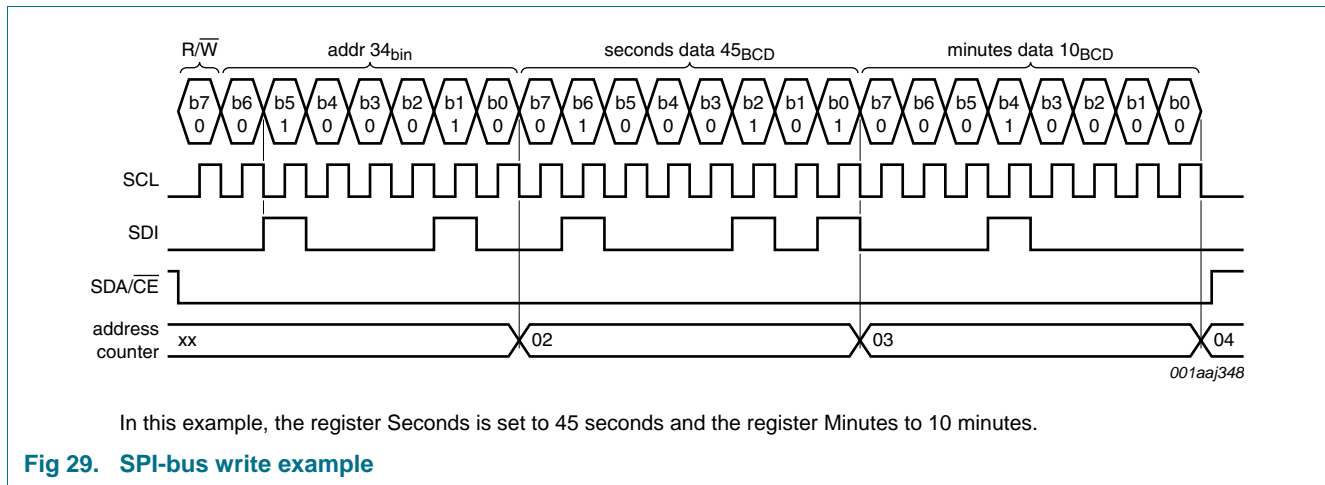

Fig 29. SPI-bus write example

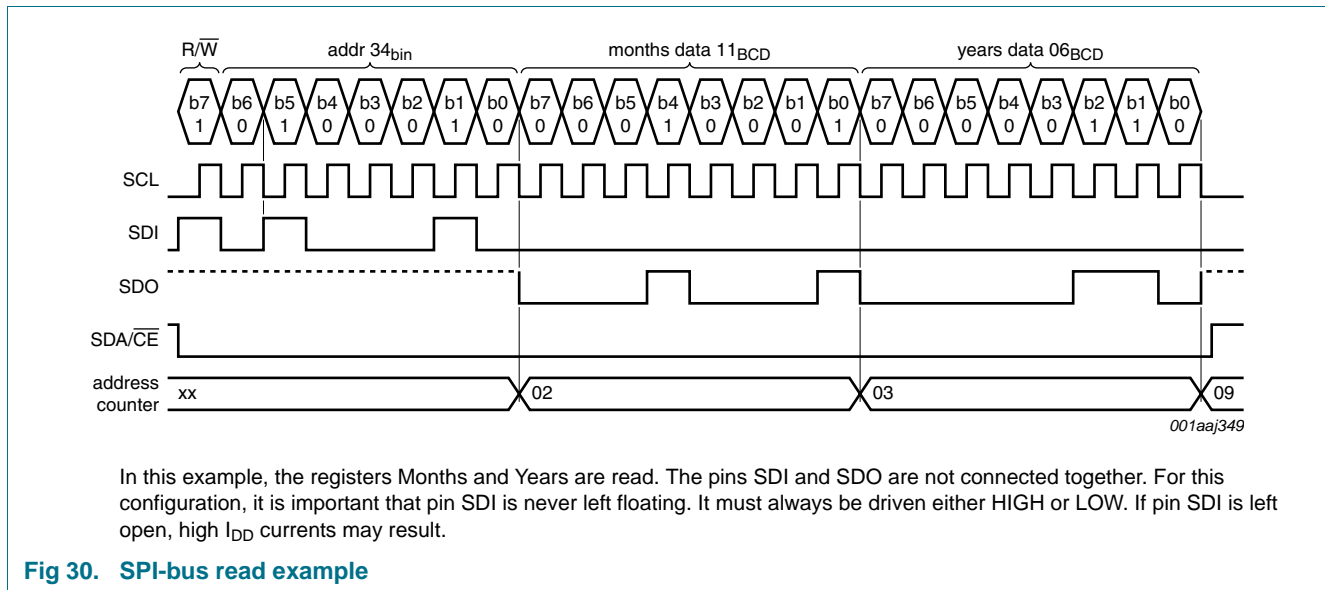

Fig 30. SPI-bus read example

## 9.2 I<sup>2</sup>C-bus interface

The I<sup>2</sup>C-bus is for bidirectional, two-line communication between different ICs or modules. The two lines are a Serial DATA line (SDA) and a Serial Clock Line (SCL). Both lines are connected to a positive supply via a pull-up resistor. Data transfer is initiated only when the bus is not busy.

### 9.2.1 Bit transfer

One data bit is transferred during each clock pulse. The data on the SDA line remains stable during the HIGH period of the clock pulse as changes in the data line at this time are interpreted as control signals (see [Figure 31](#)).

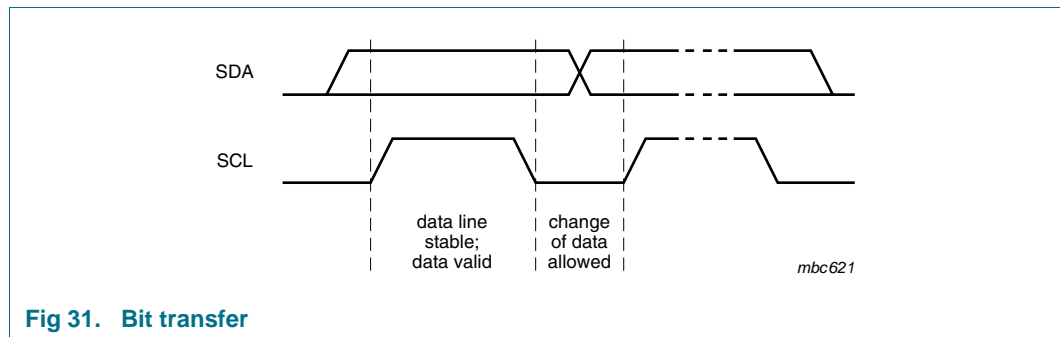

Fig 31. Bit transfer

### 9.2.2 START and STOP conditions

Both data and clock lines remain HIGH when the bus is not busy. A HIGH-to-LOW transition of the data line, while the clock is HIGH, is defined as the START condition S. A LOW-to-HIGH transition of the data line while the clock is HIGH is defined as the STOP condition P (see [Figure 32](#)).

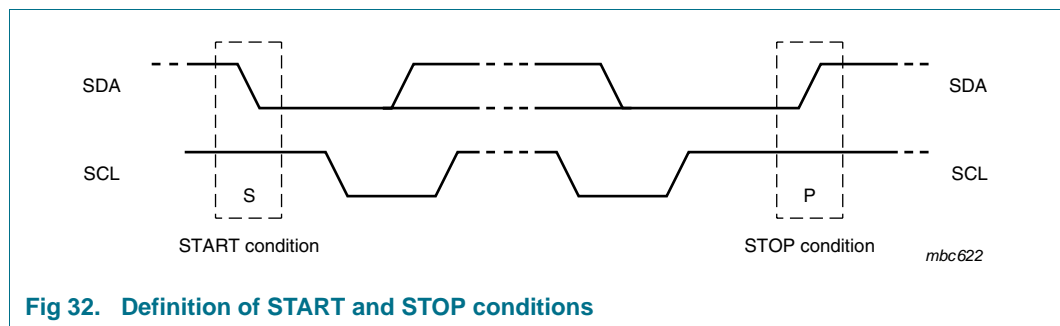

Fig 32. Definition of START and STOP conditions

For this device a repeated START is not allowed for reading. Therefore a STOP has to be released before the next START.

### 9.2.3 System configuration

A device generating a message is a transmitter; a device receiving a message is the receiver. The device that controls the message is the master; and the devices which are controlled by the master are the slaves.

The PCF2129A can act as a slave transmitter and a slave receiver.

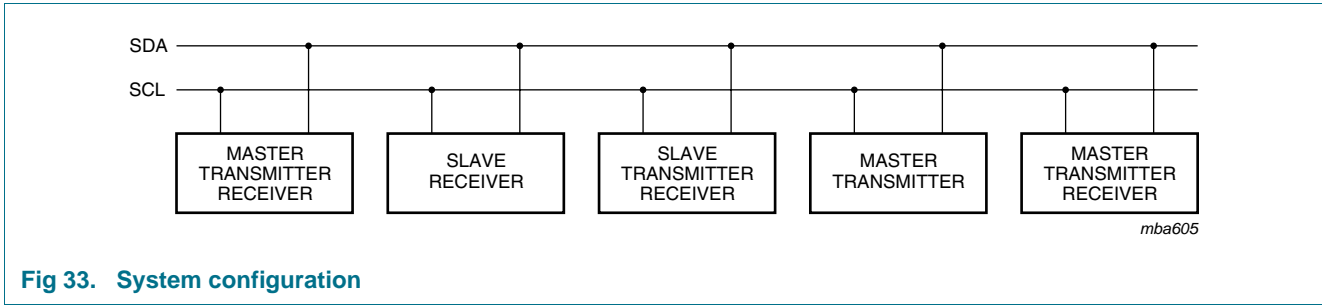

Fig 33. System configuration

9.2.4 Acknowledge

The number of data bytes transferred between the START and STOP conditions from transmitter to receiver is unlimited. Each byte of eight bits is followed by an acknowledge cycle.

- A slave receiver, which is addressed, must generate an acknowledge after the reception of each byte.
- A master receiver must generate an acknowledge after the reception of each byte that has been clocked out of the slave transmitter.
- The device that acknowledges must pull-down the SDA line during the acknowledge clock pulse, so that the SDA line is stable LOW during the HIGH period of the acknowledge related clock pulse (set-up and hold times must be taken into consideration).
- A master receiver must signal an end of data to the transmitter by not generating an acknowledge on the last byte that has been clocked out of the slave. In this event, the transmitter must leave the data line HIGH to enable the master to generate a STOP condition.

Acknowledgement on the I<sup>2</sup>C-bus is illustrated in [Figure 34](#).

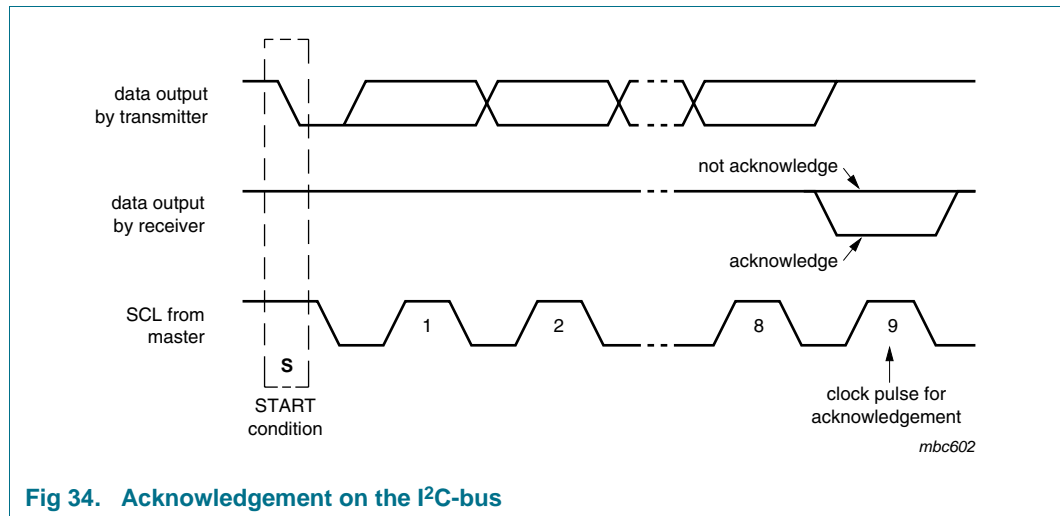

Fig 34. Acknowledgement on the I<sup>2</sup>C-bus

9.2.5 I<sup>2</sup>C-bus protocol

After a start condition a valid hardware address has to be sent to a PCF2129A device. The appropriate I<sup>2</sup>C-bus slave address is 1010001. The entire I<sup>2</sup>C-bus slave address byte is shown in [Table 50](#).



Table 50. I<sup>2</sup>C slave address byte

| Bit | Slave address |   |   |   |   |   |   | 0<br>LSB<br>R/ $\bar{W}$ |
|-----|---------------|---|---|---|---|---|---|--------------------------|
|     | 7<br>MSB      | 6 | 5 | 4 | 3 | 2 | 1 |                          |
|     | 1             | 0 | 1 | 0 | 0 | 0 | 1 |                          |

The R/ $\bar{W}$  bit defines the direction of the following single or multiple byte data transfer (read is logic 1, write is logic 0).

For the format and the timing of the START condition (S), the STOP condition (P), and the acknowledge bit (A) refer to the I<sup>2</sup>C-bus specification [Ref. 13 "UM10204"](#) and the characteristics table ([Table 55](#)). In the write mode a data transfer is terminated by sending either a STOP condition or the START condition of the next data transfer.

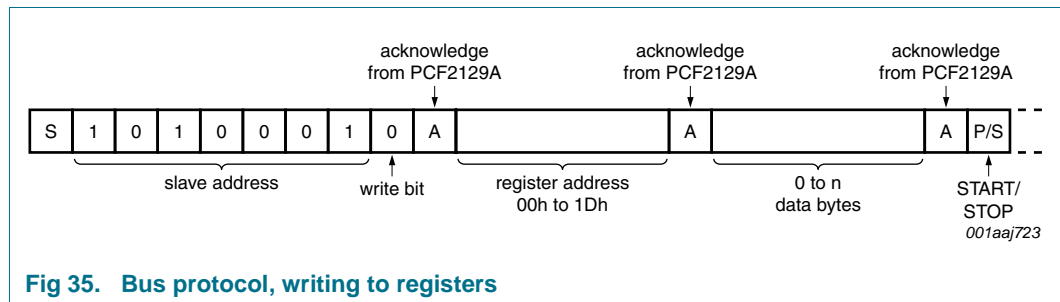

Fig 35. Bus protocol, writing to registers

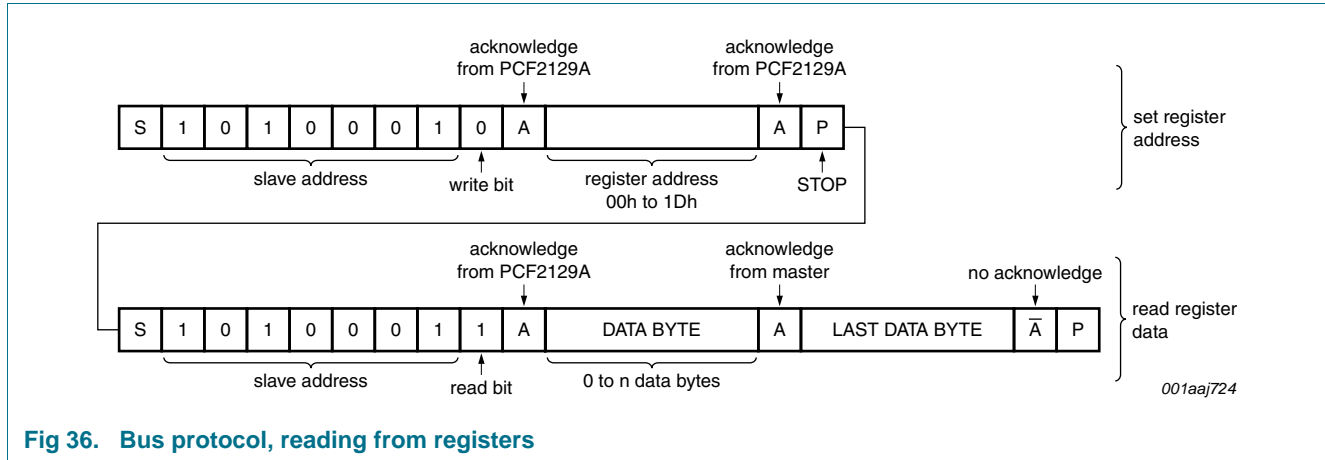

Fig 36. Bus protocol, reading from registers

10. Internal circuitry

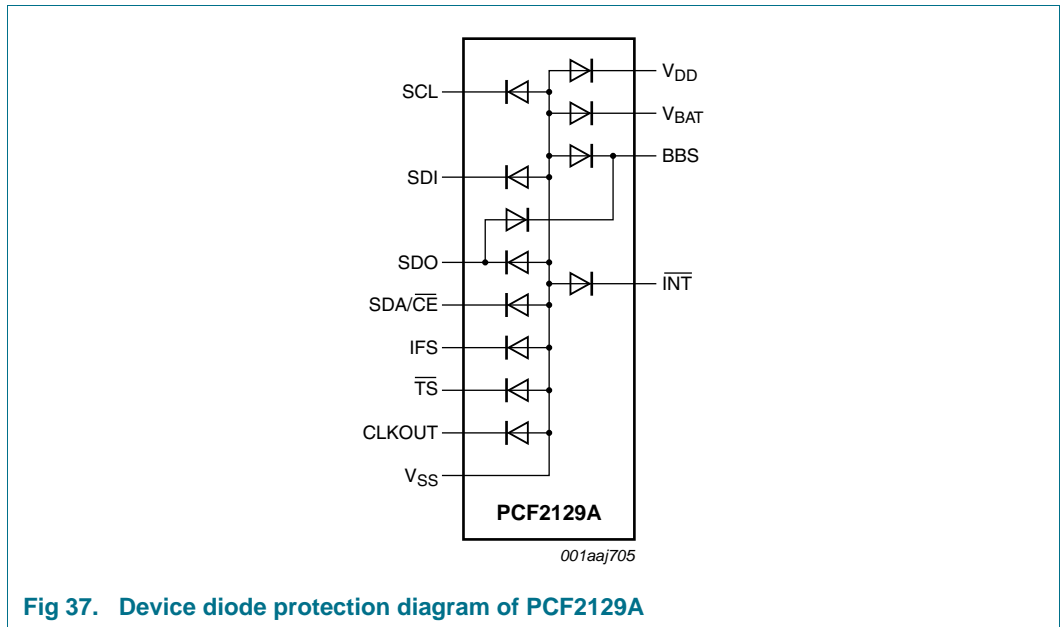

Fig 37. Device diode protection diagram of PCF2129A

## 11. Limiting values

**Table 51. Limiting values**

*In accordance with the Absolute Maximum Rating System (IEC 60134).*

| Symbol           | Parameter                       | Conditions | Min  | Max  | Unit  |    |
|------------------|---------------------------------|------------|------|------|-------|----|
| V <sub>DD</sub>  | supply voltage                  |            | -0.5 | +4.5 | V     |    |
| I <sub>DD</sub>  | supply current                  |            | -50  | +50  | mA    |    |
| V <sub>i</sub>   | input voltage                   |            | -0.5 | +6.5 | V     |    |
| I <sub>I</sub>   | input current                   |            | -10  | +10  | mA    |    |
| V <sub>O</sub>   | output voltage                  |            | -0.5 | +6.5 | V     |    |
| I <sub>O</sub>   | output current                  |            | -10  | +10  | mA    |    |
|                  |                                 | at pin SDA | -10  | +20  | mA    |    |
| V <sub>BAT</sub> | battery supply voltage          |            | -0.5 | +4.5 | V     |    |
| P <sub>tot</sub> | total power dissipation         |            | -    | 300  | mW    |    |
| T <sub>amb</sub> | ambient temperature             |            | -40  | +85  | °C    |    |
| V <sub>ESD</sub> | electrostatic discharge voltage | HBM        | [1]  | -    | ±3000 | V  |
|                  |                                 | MM         | [2]  | -    | ±250  | V  |
|                  |                                 | CDM        | [3]  | -    | ±1500 | V  |
| I <sub>Iu</sub>  | latch-up current                |            | [4]  | -    | 200   | mA |
| T <sub>stg</sub> | storage temperature             |            | [5]  | -55  | +85   | °C |

[1] Pass level; Human Body Model (HBM) according to [Ref. 7 "JESD22-A114"](#).

[2] Pass level; Machine Model (MM), according to [Ref. 8 "JESD22-A115"](#).

[3] Pass level; Charged-Device Model (CDM), according to [Ref. 9 "JESD22-C101"](#).

[4] Pass level; latch-up testing according to [Ref. 10 "JESD78"](#) at maximum ambient temperature (T<sub>amb(max)</sub>).

[5] According to the NXP store and transport requirements (see [Ref. 12 "NX3-00092"](#)) the devices have to be stored at a temperature of +8 °C to +45 °C and a humidity of 25 % to 75 %. For long term storage products deviant conditions are described in that document.

## 12. Static characteristics

**Table 52. Static characteristics**
 $V_{DD} = 1.8 \text{ V to } 4.2 \text{ V}; V_{SS} = 0 \text{ V}; T_{amb} = -40 \text{ }^{\circ}\text{C to } +85 \text{ }^{\circ}\text{C}$ , unless otherwise specified.

| Symbol                   | Parameter                        | Conditions   | Min     | Typ  | Max  | Unit          |  |  |
|--------------------------|----------------------------------|--|---------|------|------|---------------|--|--|
| <b>Supplies</b>          |                                  |  |         |      |      |               |  |  |
| $V_{DD}$                 | supply voltage                   |  | [1] 1.8 | -    | 4.2  | V             |  |  |
| $V_{BAT}$                | battery supply voltage           |  | 1.8     | -    | 4.2  | V             |  |  |
| $V_{DD(cal)}$            | calibration supply voltage       |  | -       | 3.3  | -    | V             |  |  |
| $V_{low}$                | low voltage                      |  | -       | 1.2  | -    | V             |  |  |
| $I_{DD}$                 | supply current                   | interface active   |         |      |      |               |  |  |
|                          |                                  | SPI-bus  |         |      |      |               |  |  |
|                          |                                  | $f_{SCL} = 6.5 \text{ MHz}$  | -       | -    | 800  | $\mu\text{A}$ |  |  |
|                          |                                  | $f_{SCL} = 1.0 \text{ MHz}$  | -       | -    | 200  | $\mu\text{A}$ |  |  |
|                          |                                  | I <sup>2</sup> C-bus   |         |      |      |               |  |  |
|                          |                                  | $f_{SCL} = 1.0 \text{ MHz}$  | -       | -    | 200  | $\mu\text{A}$ |  |  |
|                          |                                  | interface inactive ( $f_{SCL} = 0 \text{ Hz}$ )  |         |      |      |               |  |  |
|                          |                                  | CLKOUT disabled (COF[2:0] = 111), one power supply $V_{DD}$ (PWRMNG[2:0] = 111), timestamp detection disabled (TSOFF = 1)[2] |         |      |      |               |  |  |
|                          |                                  | $V_{DD} = 2.0 \text{ V}$   | -       | 500  | -    | nA            |  |  |
|                          |                                  | $V_{DD} = 3.3 \text{ V}$   | -       | 700  | 1500 | nA            |  |  |
|                          |                                  | $V_{DD} = 4.2 \text{ V}$   | -       | 800  | -    | nA            |  |  |
|                          |                                  | CLKOUT enabled at 32 kHz (default), one power supply $V_{DD}$ (PWRMNG[2:0] = 111), timestamp detection disabled (TSOFF = 1)  |         |      |      |               |  |  |
|                          |                                  | $V_{DD} = 2.0 \text{ V}$   | -       | 600  | -    | nA            |  |  |
|                          |                                  | $V_{DD} = 3.3 \text{ V}$   | -       | 850  | -    | nA            |  |  |
|                          |                                  | $V_{DD} = 4.2 \text{ V}$   | -       | 1050 | -    | nA            |  |  |
|                          |                                  | CLKOUT disabled (COF[2:0] = 111), power management functions enabled (default), timestamp detection enabled (default)        |         |      |      |               |  |  |
|                          |                                  | $V_{DD} = 2.0 \text{ V}$   | -       | 1800 | -    | nA            |  |  |
|                          |                                  | $V_{DD} = 3.3 \text{ V}$   | -       | 2150 | -    | nA            |  |  |
|                          |                                  | $V_{DD} = 4.2 \text{ V}$   | -       | 2350 | 3500 | nA            |  |  |
|                          |                                  | CLKOUT enabled at 32 kHz (default); power management functions enabled (default), timestamp detection enabled (default)      |         |      |      |               |  |  |
| $V_{DD} = 2.0 \text{ V}$ | -                                | 1900   | -       | nA   |      |               |  |  |
| $V_{DD} = 3.3 \text{ V}$ | -                                | 2300   | -       | nA   |      |               |  |  |
| $V_{DD} = 4.2 \text{ V}$ | -                                | 2600   | -       | nA   |      |               |  |  |
| $I_{BAT}$                | battery supply current           | $V_{DD}$ active;<br>$V_{BAT} = 3.0 \text{ V}$  | -       | 50   | 100  | nA            |  |  |
| <b>Power management</b>  |                                  |  |         |      |      |               |  |  |
| $V_{th(sw)bat}$          | battery switch threshold voltage |  | -       | 2.5  | -    | V             |  |  |
| $V_{th(bat)low}$         | low battery threshold voltage    |  | -       | 2.5  | -    | V             |  |  |

**Table 52. Static characteristics ...continued**  
 $V_{DD} = 1.8\text{ V to }4.2\text{ V}$ ;  $V_{SS} = 0\text{ V}$ ;  $T_{amb} = -40\text{ }^{\circ}\text{C to }+85\text{ }^{\circ}\text{C}$ , unless otherwise specified.

| Symbol         | Parameter                 | Conditions  | Min         | Typ | Max             | Unit          |
|----------------|---------------------------|---|-------------|-----|-----------------|---------------|
| <b>Inputs</b>  |                           |   |             |     |                 |               |
| $V_I$          | input voltage             |   | -0.5        | -   | $V_{DD} + 0.5$  | V             |
| $V_{IL}$       | LOW-level input voltage   |   | -           | -   | $0.25V_{DD}$    | V             |
|                |                           | $T_{amb} = -20\text{ }^{\circ}\text{C to }+85\text{ }^{\circ}\text{C}$ ;<br>$V_{DD} > 2.0\text{ V}$ | -           | -   | $0.3V_{DD}$     | V             |
| $V_{IH}$       | HIGH-level input voltage  |   | $0.7V_{DD}$ | -   | -               | V             |
| $I_{LI}$       | input leakage current     | $V_I = V_{DD}\text{ or }V_{SS}$   | -1          | 0   | +1              | $\mu\text{A}$ |
| $C_i$          | input capacitance         |   | [3]         | -   | 7               | pF            |
| <b>Outputs</b> |                           |   |             |     |                 |               |
| $V_O$          | output voltage            | on pins CLKOUT, $\overline{\text{INT}}$ ,<br>referring to external pull-up                          | -0.5        | -   | 5.5             | V             |
|                |                           | on pin SDO  | -0.5        | -   | $V_{BBS} + 0.5$ | V             |
| $I_{OL}$       | LOW-level output current  | output sink current;<br>$V_{OL} = 0.4\text{ V}$ ; $V_{DD} = 4.2\text{ V}$                           |             |     |                 |               |
|                |                           | on pin SDA  | 20          | -   | -               | mA            |
|                |                           | on all other outputs  | 1.0         | -   | -               | mA            |
| $I_{OH}$       | HIGH-level output current | output source current;<br>on pin SDO; $V_{OH} = 3.8\text{ V}$ ;<br>$V_{DD} = 4.2\text{ V}$          | 1.0         | -   | -               | mA            |
| $I_{LO}$       | output leakage current    | $V_O = V_{DD}\text{ or }V_{SS}$   | -1          | 0   | 1               | $\mu\text{A}$ |

[1] For reliable oscillator start-up at power-on:  $V_{DD(po)min} = V_{DD(min)} + 0.3\text{ V}$ .  
 [2] Timer source clock =  $\frac{1}{60}\text{ Hz}$ , level of pins SDA/ $\overline{\text{CE}}$ , SDI, and SCL is  $V_{DD}$  or  $V_{SS}$ .  
 [3] Tested on sample basis.

### 12.1 Current consumption $I_{DD}$ characteristics, typical

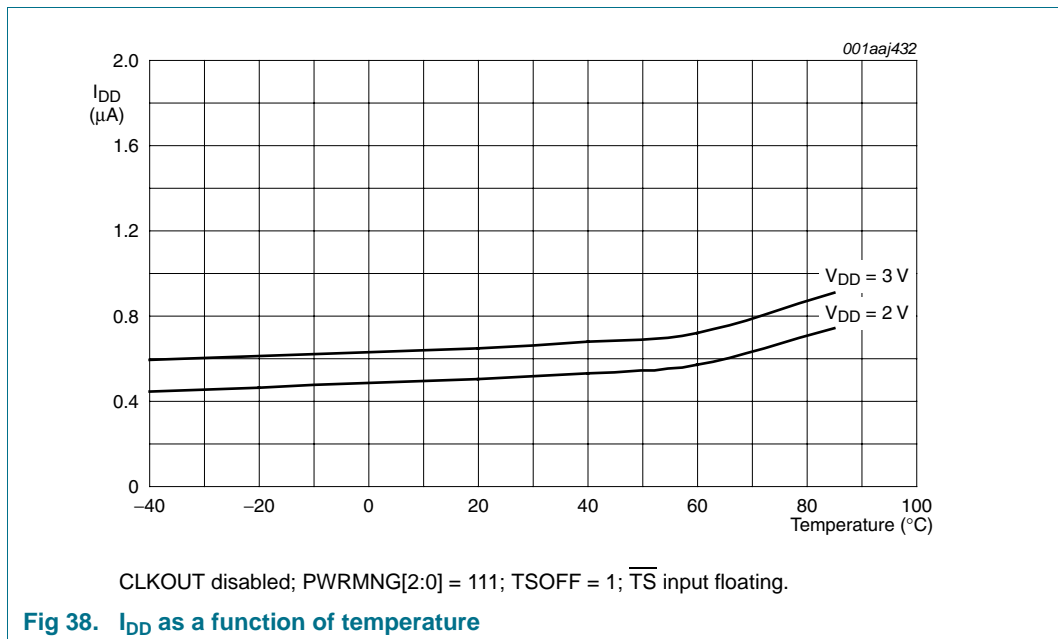

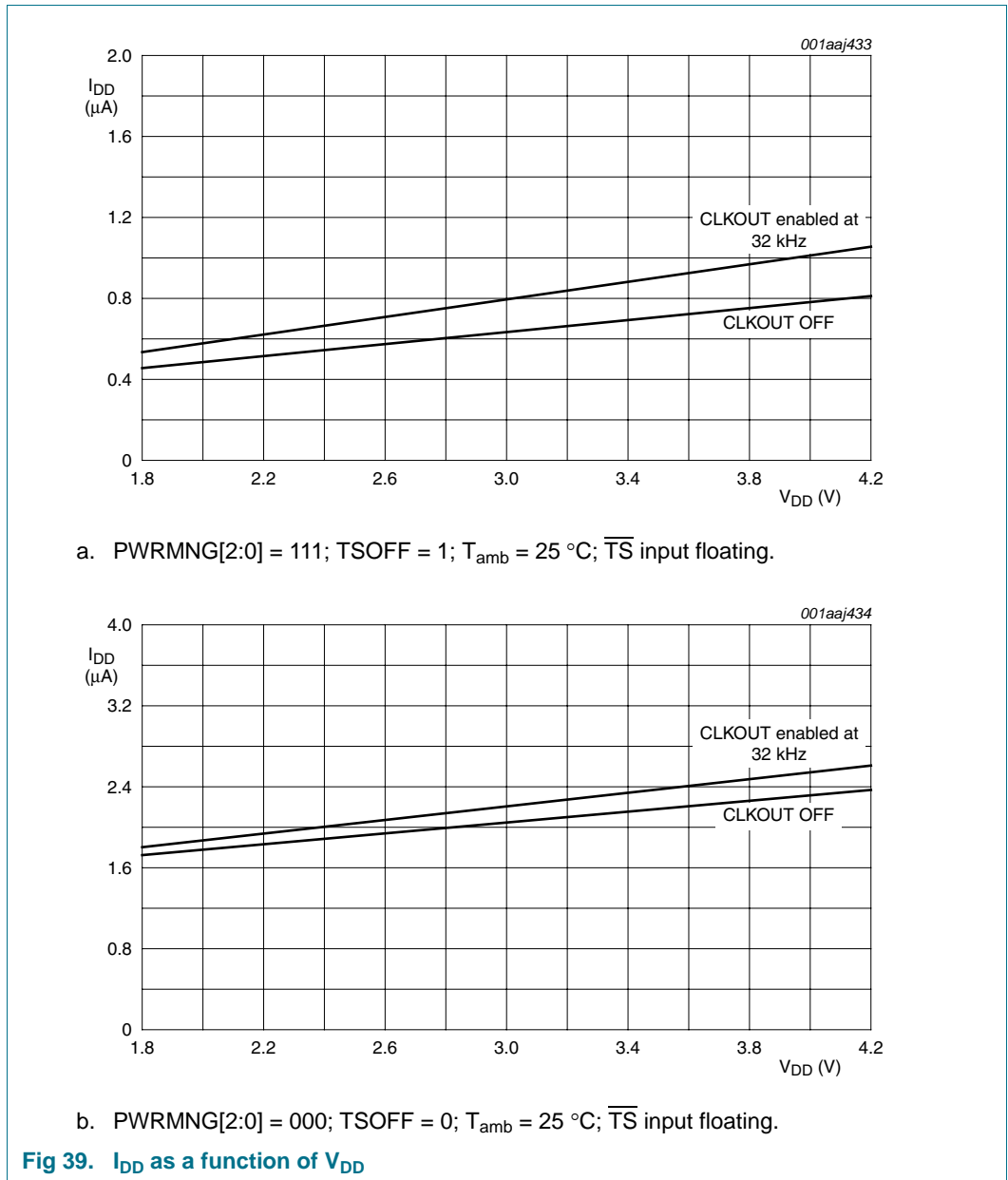

12.2 Frequency characteristics

Table 53. Frequency characteristics

$V_{DD} = 1.8\text{ V to }4.2\text{ V}$ ;  $V_{SS} = 0\text{ V}$ ;  $T_{amb} = +25\text{ }^\circ\text{C}$ , unless otherwise specified.

| Symbol                     | Parameter                            | Conditions  | Min   | Typ     | Max      | Unit  |
|----------------------------|--------------------------------------|---|-------|---------|----------|-------|
| $f_o$                      | output frequency                     | on pin CLKOUT;<br>$V_{DD}$ or $V_{BAT} = 3.3\text{ V}$ ;<br>COF[2:0] = 000;<br>AO[3:0] = 1000   | -     | 32.768  | -        | kHz   |
| $\Delta f/f$               | frequency stability                  | $V_{DD}$ or $V_{BAT} = 3.3\text{ V}$  |       |         |          |       |
|                            |                                      | $T_{amb} = -15\text{ }^\circ\text{C to }+60\text{ }^\circ\text{C}$  | [1] - | $\pm 3$ | $\pm 5$  | ppm   |
|                            |                                      | $T_{amb} = -25\text{ }^\circ\text{C to }-15\text{ }^\circ\text{C}$<br>and<br>$T_{amb} = +60\text{ }^\circ\text{C to }+65\text{ }^\circ\text{C}$ | [1] - | $\pm 5$ | $\pm 10$ | ppm   |
| $\Delta f_{xtal}/f_{xtal}$ | relative crystal frequency variation | crystal aging, first year;<br>$V_{DD}$ or $V_{BAT} = 3.3\text{ V}$  | [2] - | -       | $\pm 3$  | ppm   |
| $\Delta f/\Delta V$        | frequency variation with voltage     | on pin CLKOUT   | -     | $\pm 1$ | -        | ppm/V |

[1]  $\pm 1\text{ ppm}$  corresponds to a time deviation of  $\pm 0.0864$  seconds per day.

[2] Not production tested. Effects of reflow solder not included (see [Ref. 3 "AN10857"](#)).

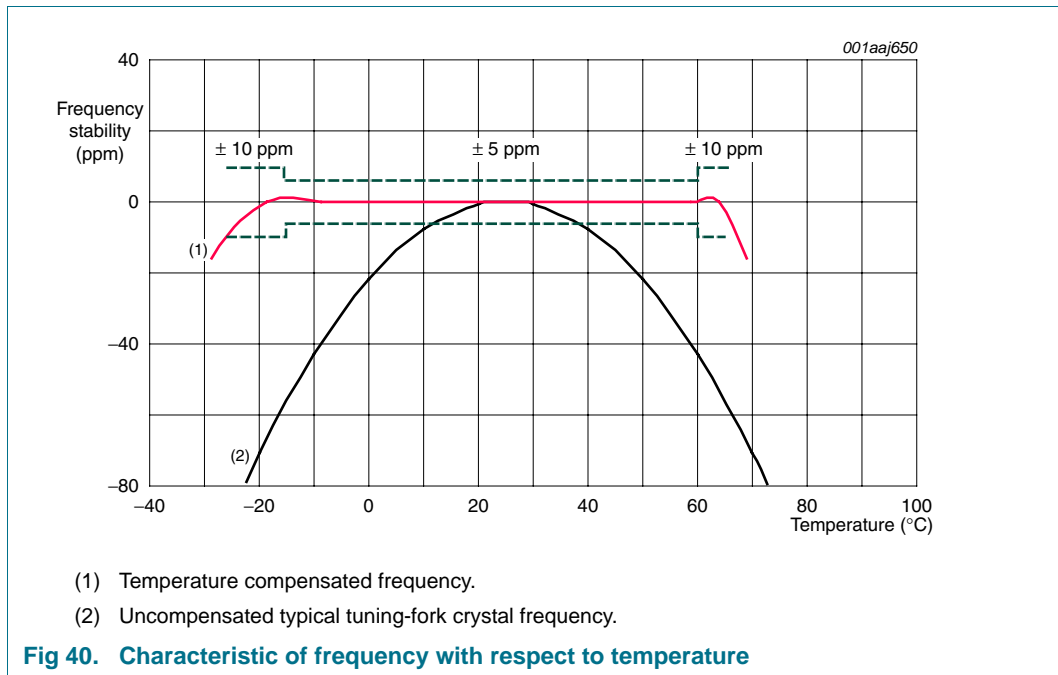

## 13. Dynamic characteristics

### 13.1 SPI-bus timing characteristics

**Table 54. SPI-bus characteristics**

$V_{DD} = 1.8\text{ V to }4.2\text{ V}$ ;  $V_{SS} = 0\text{ V}$ ;  $T_{amb} = -40\text{ °C to }+85\text{ °C}$ , unless otherwise specified. All timing values are valid within the operating supply voltage at ambient temperature and referenced to  $V_{IL}$  and  $V_{IH}$  with an input voltage swing of  $V_{SS}$  to  $V_{DD}$  (see [Figure 41](#)).

| Symbol                | Parameter                       | Conditions               | $V_{DD} = 1.8\text{ V}$ |      | $V_{DD} = 4.2\text{ V}$ |      | Unit |
|-----------------------|---------------------------------|--------------------------|-------------------------|------|-------------------------|------|------|
|                       |                                 |                          | Min                     | Max  | Min                     | Max  |      |
| <b>Pin SCL</b>        |                                 |                          |                         |      |                         |      |      |
| $f_{clk(SCL)}$        | SCL clock frequency             |                          | -                       | 2.0  | -                       | 6.5  | MHz  |
| $t_{SCL}$             | SCL time                        |                          | 800                     | -    | 140                     | -    | ns   |
| $t_{clk(H)}$          | clock HIGH time                 |                          | 100                     | -    | 70                      | -    | ns   |
| $t_{clk(L)}$          | clock LOW time                  |                          | 400                     | -    | 70                      | -    | ns   |
| $t_r$                 | rise time                       | for SCL signal           | -                       | 100  | -                       | 30   | ns   |
| $t_f$                 | fall time                       | for SCL signal           | -                       | 100  | -                       | 30   | ns   |
| <b>Pin CE</b>         |                                 |                          |                         |      |                         |      |      |
| $t_{su(CE\_N)}$       | CE_N set-up time                |                          | 60                      | -    | 30                      | -    | ns   |
| $t_{h(CE\_N)}$        | CE_N hold time                  |                          | 40                      | -    | 25                      | -    | ns   |
| $t_{rec(CE\_N)}$      | CE_N recovery time              |                          | 100                     | -    | 30                      | -    | ns   |
| $t_w(CE\_N)$          | CE_N pulse width                |                          | -                       | 0.99 | -                       | 0.99 | s    |
| <b>Pin SDI</b>        |                                 |                          |                         |      |                         |      |      |
| $t_{su}$              | set-up time                     | set-up time for SDI data | 70                      | -    | 20                      | -    | ns   |
| $t_h$                 | hold time                       | hold time for SDI data   | 70                      | -    | 20                      | -    | ns   |
| <b>Pin SDO</b>        |                                 |                          |                         |      |                         |      |      |
| $t_{d(R)SDO}$         | SDO read delay time             | $C_L = 50\text{ pF}$     | -                       | 225  | -                       | 55   | ns   |
| $t_{dis(SDO)}$        | SDO disable time                | <a href="#">[1]</a>      | -                       | 90   | -                       | 25   | ns   |
| $t_t(SDI\text{-}SDO)$ | transition time from SDI to SDO | to avoid bus conflict    | 0                       | -    | 0                       | -    | ns   |

[1] No load value; bus will be held up by bus capacitance; use RC time constant with application values.



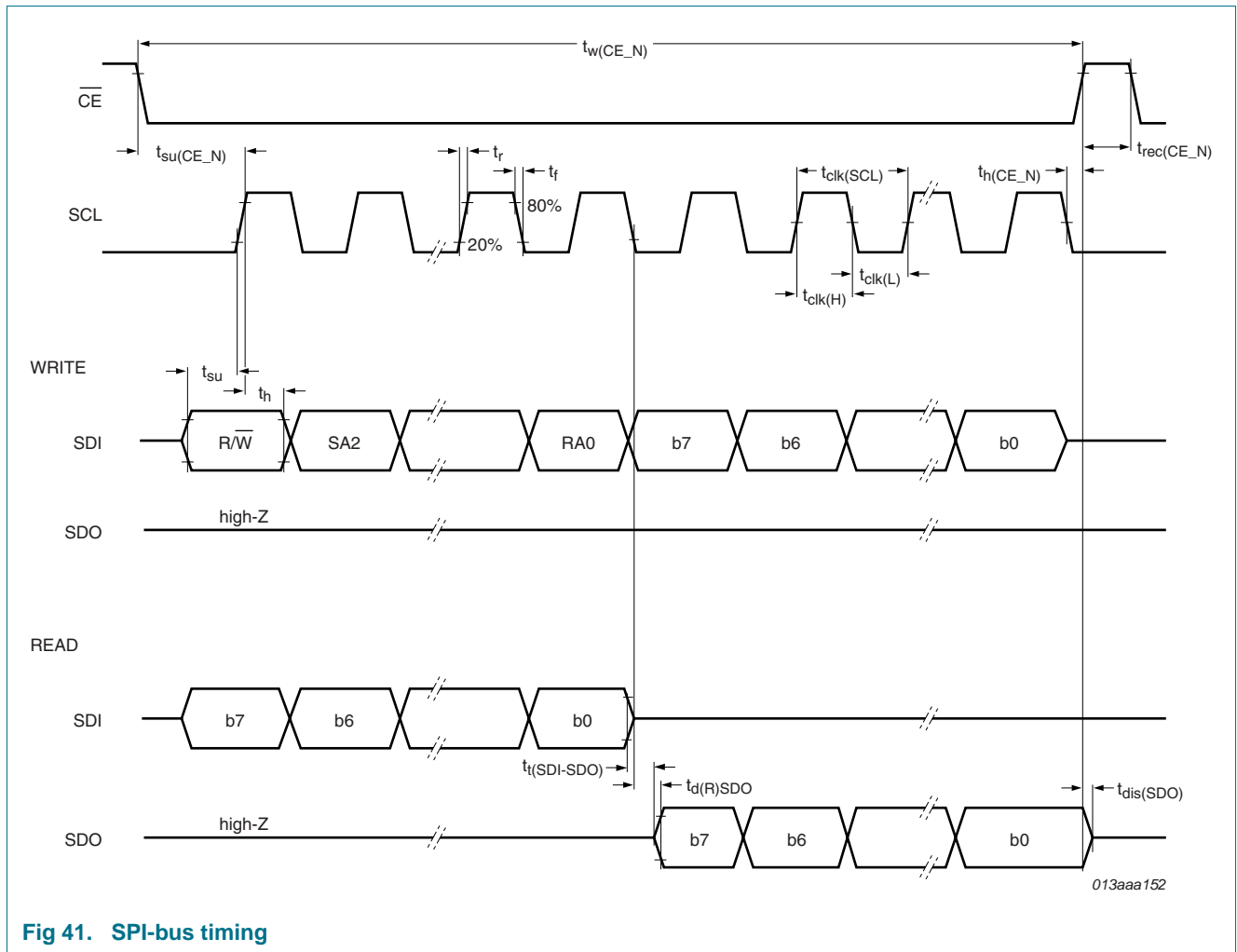

Fig 41. SPI-bus timing

## 13.2 I<sup>2</sup>C-bus timing characteristics

**Table 55. I<sup>2</sup>C-bus characteristics**

All timing characteristics are valid within the operating supply voltage and ambient temperature range and reference to 30 % and 70 % with an input voltage swing of  $V_{SS}$  to  $V_{DD}$  (see [Figure 42](#)).

| Symbol                  | Parameter   | Standard mode |      | Fast-mode (Fm) |     | Fast-mode Plus (Fm+) |      | Unit    |
|-------------------------|---|---------------|------|----------------|-----|----------------------|------|---------|
|                         |   | Min           | Max  | Min            | Max | Min                  | Max  |         |
| <b>Pin SCL</b>          |   |               |      |                |     |                      |      |         |
| $f_{SCL}$               | SCL clock frequency   | [1] 0         | 100  | 0              | 400 | 0                    | 1000 | kHz     |
| $t_{LOW}$               | LOW period of the SCL clock                                       | 4.7           | -    | 1.3            | -   | 0.5                  | -    | $\mu$ s |
| $t_{HIGH}$              | HIGH period of the SCL clock                                      | 4.0           | -    | 0.6            | -   | 0.26                 | -    | $\mu$ s |
| <b>Pin SDA</b>          |   |               |      |                |     |                      |      |         |
| $t_{SU;DAT}$            | data set-up time  | 250           | -    | 100            | -   | 50                   | -    | ns      |
| $t_{HD;DAT}$            | data hold time  | 0             | -    | 0              | -   | 0                    | -    | ns      |
| <b>Pins SCL and SDA</b> |   |               |      |                |     |                      |      |         |
| $t_{BUF}$               | bus free time between a STOP and START condition                  | 4.7           | -    | 1.3            | -   | 0.5                  | -    | $\mu$ s |
| $t_{SU;STO}$            | set-up time for STOP condition                                    | 4.0           | -    | 0.6            | -   | 0.26                 | -    | $\mu$ s |
| $t_{HD;STA}$            | hold time (repeated) START condition                              | 4.0           | -    | 0.6            | -   | 0.26                 | -    | $\mu$ s |
| $t_{SU;STA}$            | set-up time for a repeated START condition                        | 4.7           | -    | 0.6            | -   | 0.26                 | -    | $\mu$ s |
| $t_r$                   | rise time of both SDA and SCL signals                             | [2][3][4] -   | 1000 | $20 + 0.1C_b$  | 300 | -                    | 120  | ns      |
| $t_f$                   | fall time of both SDA and SCL signals                             | [2][3][4] -   | 300  | $20 + 0.1C_b$  | 300 | -                    | 120  | ns      |
| $t_{VD;ACK}$            | data valid acknowledge time                                       | [5] 0.1       | 3.45 | 0.1            | 0.9 | 0.05                 | 0.45 | $\mu$ s |
| $t_{VD;DAT}$            | data valid time   | [6] 300       | -    | 75             | -   | 75                   | 450  | ns      |
| $t_{SP}$                | pulse width of spikes that must be suppressed by the input filter | [7] -         | 50   | -              | 50  | -                    | 50   | ns      |

[1] The minimum SCL clock frequency is limited by the bus time-out feature which resets the serial bus interface if either the SDA or SCL is held LOW for a minimum of 25 ms. The bus time-out feature must be disabled for DC operation.

[2] A master device must internally provide a hold time of at least 300 ns for the SDA signal (refer to the  $V_{IL}$  of the SCL signal) in order to bridge the undefined region of the SCL's falling edge.

[3]  $C_b$  is the total capacitance of one bus line in pF.

[4] The maximum  $t_r$  for the SDA and SCL bus lines is 300 ns. The maximum fall time for the SDA output stage,  $t_f$  is 250 ns. This allows series protection resistors to be connected between the SDA pin, the SCL pin, and the SDA/SCL bus lines without exceeding the maximum  $t_f$ .

[5]  $t_{VD;ACK}$  is the time of the acknowledgement signal from SCL LOW to SDA (out) LOW.

[6]  $t_{VD;DAT}$  is the minimum time for valid SDA (out) data following SCL LOW.

[7] Input filters on the SDA and SCL inputs suppress noise spikes of less than 50 ns.

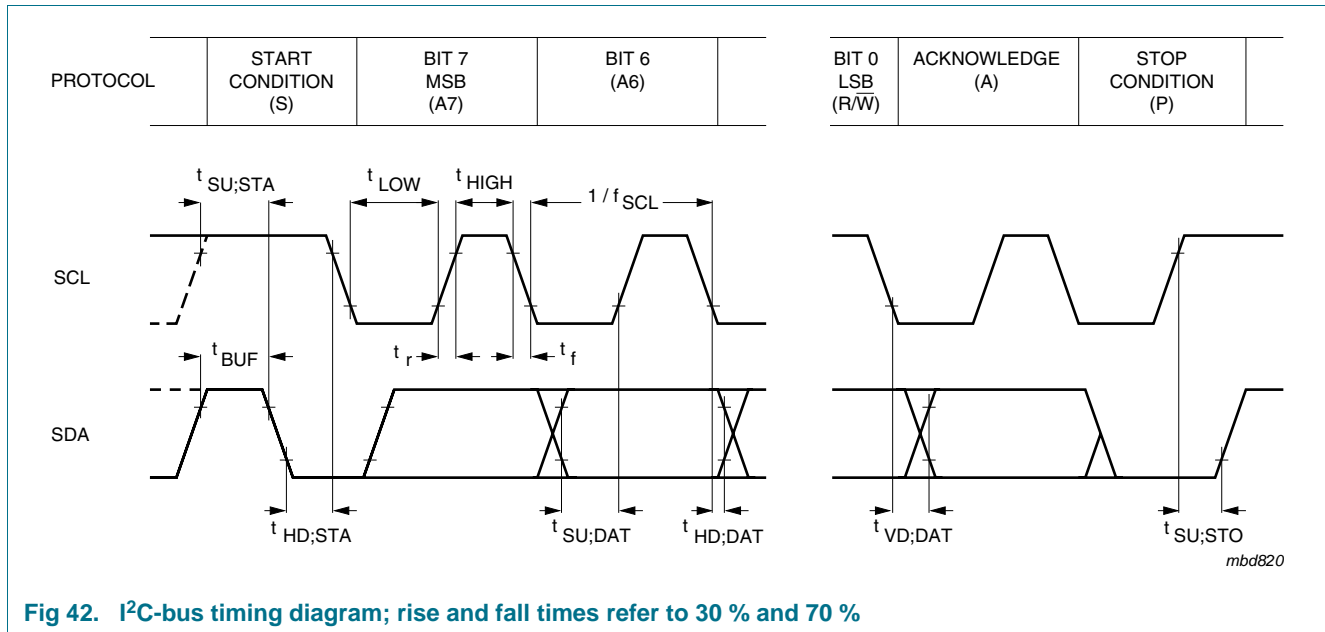

Fig 42. I<sup>2</sup>C-bus timing diagram; rise and fall times refer to 30 % and 70 %

## 14. Application information

For information about application configuration see [Ref. 3 "AN10857"](#).

15. Package outline

SO20: plastic small outline package; 20 leads; body width 7.5 mm

SOT163-1

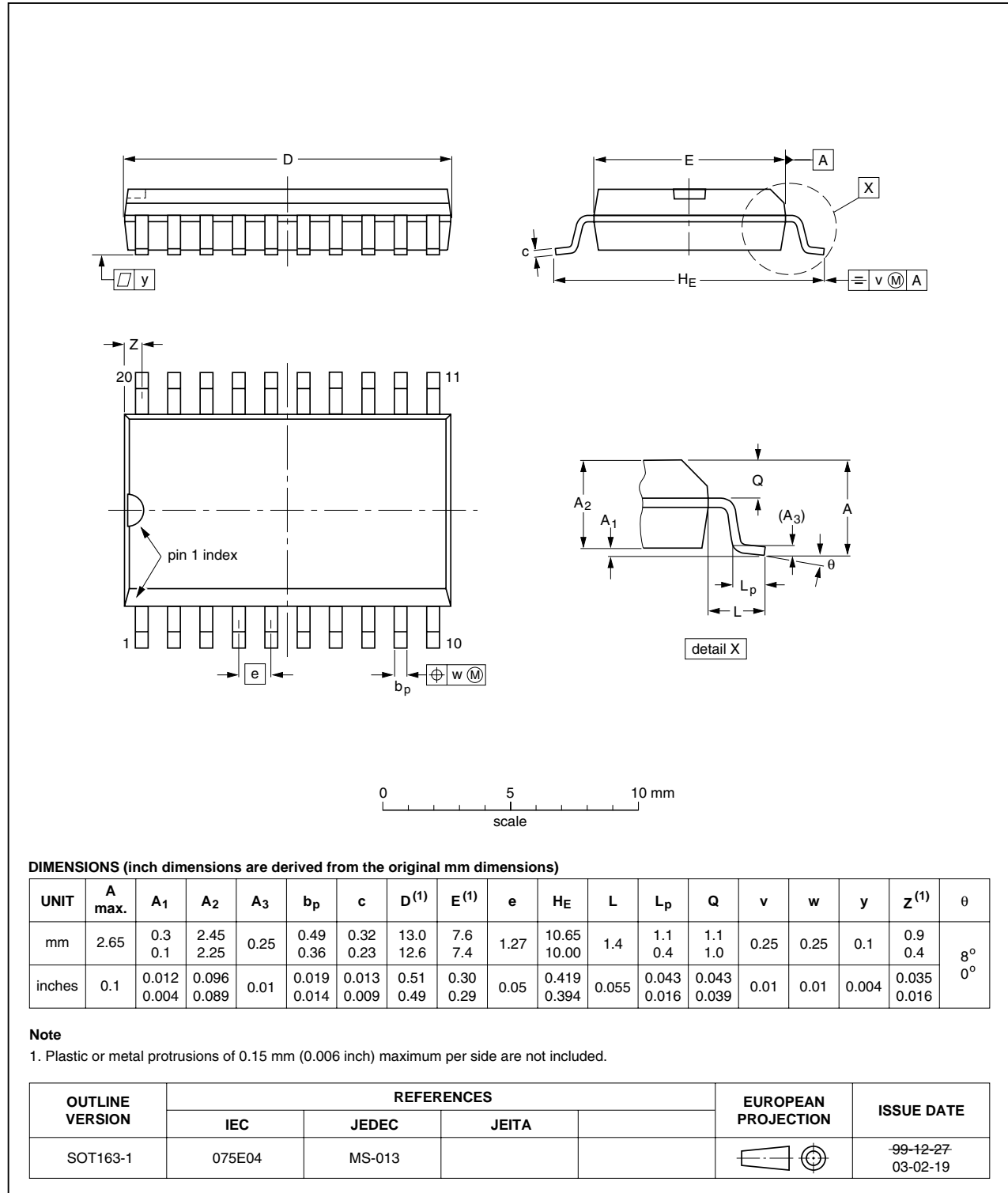

Fig 43. Package outline SOT163-1 (SO20)

## 16. Soldering

For information about soldering see [Ref. 3 “AN10857”](#).

## 17. Abbreviations

**Table 56. Abbreviations**

| Acronym          | Description                             |
|------------------|---|
| AM               | Ante Meridiem                           |
| BCD              | Binary Coded Decimal                    |
| CDM              | Charged-Device Model                    |
| CMOS             | Complementary Metal Oxide Semiconductor |
| DC               | Direct Current                          |
| GPS              | Global Positioning System               |
| HBM              | Human Body Model                        |
| I <sup>2</sup> C | Inter-Integrated Circuit                |
| IC               | Integrated Circuit                      |
| LSB              | Least Significant Bit                   |
| MCU              | Microcontroller Unit                    |
| MM               | Machine Model                           |
| MSB              | Most Significant Bit                    |
| PM               | Post Meridiem                           |
| POR              | Power-On Reset                          |
| PORO             | Power-On Reset Override                 |
| PPM              | Parts Per Million                       |
| RC               | Resistance-Capacitance                  |
| RTC              | Real Time Clock                         |
| SCL              | Serial Clock Line                       |
| SDA              | Serial DATA line                        |
| SPI              | Serial Peripheral Interface             |
| SRAM             | Static Random Access Memory             |
| TCXO             | Temperature Compensated Xtal Oscillator |
| Xtal             | crystal                                 |

## 18. References

---

- [1] **AN10365** — Surface mount reflow soldering description
- [2] **AN10853** — Handling precautions of ESD sensitive devices
- [3] **AN10857** — Application and soldering information for PCF2127A and PCF2129A TCXO RTC
- [4] **IEC 60134** — Rating systems for electronic tubes and valves and analogous semiconductor devices
- [5] **IEC 61340-5** — Protection of electronic devices from electrostatic phenomena
- [6] **IPC/JEDEC J-STD-020D** — Moisture/Reflow Sensitivity Classification for Nonhermetic Solid State Surface Mount Devices
- [7] **JESD22-A114** — Electrostatic Discharge (ESD) Sensitivity Testing Human Body Model (HBM)
- [8] **JESD22-A115** — Electrostatic Discharge (ESD) Sensitivity Testing Machine Model (MM)
- [9] **JESD22-C101** — Field-Induced Charged-Device Model Test Method for Electrostatic-Discharge-Withstand Thresholds of Microelectronic Components
- [10] **JESD78** — IC Latch-Up Test
- [11] **JESD625-A** — Requirements for Handling Electrostatic-Discharge-Sensitive (ESDS) Devices
- [12] **NX3-00092** — NXP store and transport requirements
- [13] **UM10204** — I<sup>2</sup>C-bus specification and user manual

## 19. Revision history

Table 57. Revision history

| Document ID | Release date | Data sheet status  | Change notice | Supersedes |
|-------------|--------------|--------------------|---------------|------------|
| PCF2129A_1  | 20100113     | Product data sheet | -             | -          |

## 20. Legal information

### 20.1 Data sheet status

| Document status <sup>[1][2]</sup> | Product status <sup>[3]</sup> | Definition  |
|-----------------------------------|-------------------------------|---|
| Objective [short] data sheet      | Development                   | This document contains data from the objective specification for product development. |
| Preliminary [short] data sheet    | Qualification                 | This document contains data from the preliminary specification.                       |
| Product [short] data sheet        | Production                    | This document contains the product specification.                                     |

[1] Please consult the most recently issued document before initiating or completing a design.

[2] The term 'short data sheet' is explained in section "Definitions".

[3] The product status of device(s) described in this document may have changed since this document was published and may differ in case of multiple devices. The latest product status information is available on the Internet at URL <http://www.nxp.com>.

### 20.2 Definitions

**Draft** — The document is a draft version only. The content is still under internal review and subject to formal approval, which may result in modifications or additions. NXP Semiconductors does not give any representations or warranties as to the accuracy or completeness of information included herein and shall have no liability for the consequences of use of such information.

**Short data sheet** — A short data sheet is an extract from a full data sheet with the same product type number(s) and title. A short data sheet is intended for quick reference only and should not be relied upon to contain detailed and full information. For detailed and full information see the relevant full data sheet, which is available on request via the local NXP Semiconductors sales office. In case of any inconsistency or conflict with the short data sheet, the full data sheet shall prevail.

### 20.3 Disclaimers

**General** — Information in this document is believed to be accurate and reliable. However, NXP Semiconductors does not give any representations or warranties, expressed or implied, as to the accuracy or completeness of such information and shall have no liability for the consequences of use of such information.

**Right to make changes** — NXP Semiconductors reserves the right to make changes to information published in this document, including without limitation specifications and product descriptions, at any time and without notice. This document supersedes and replaces all information supplied prior to the publication hereof.

**Suitability for use** — NXP Semiconductors products are not designed, authorized or warranted to be suitable for use in medical, military, aircraft, space or life support equipment, nor in applications where failure or malfunction of an NXP Semiconductors product can reasonably be expected to result in personal injury, death or severe property or environmental

damage. NXP Semiconductors accepts no liability for inclusion and/or use of NXP Semiconductors products in such equipment or applications and therefore such inclusion and/or use is at the customer's own risk.

**Applications** — Applications that are described herein for any of these products are for illustrative purposes only. NXP Semiconductors makes no representation or warranty that such applications will be suitable for the specified use without further testing or modification.

**Limiting values** — Stress above one or more limiting values (as defined in the Absolute Maximum Ratings System of IEC 60134) may cause permanent damage to the device. Limiting values are stress ratings only and operation of the device at these or any other conditions above those given in the Characteristics sections of this document is not implied. Exposure to limiting values for extended periods may affect device reliability.

**Terms and conditions of sale** — NXP Semiconductors products are sold subject to the general terms and conditions of commercial sale, as published at <http://www.nxp.com/profile/terms>, including those pertaining to warranty, intellectual property rights infringement and limitation of liability, unless explicitly otherwise agreed to in writing by NXP Semiconductors. In case of any inconsistency or conflict between information in this document and such terms and conditions, the latter will prevail.

**No offer to sell or license** — Nothing in this document may be interpreted or construed as an offer to sell products that is open for acceptance or the grant, conveyance or implication of any license under any copyrights, patents or other industrial or intellectual property rights.

**Export control** — This document as well as the item(s) described herein may be subject to export control regulations. Export might require a prior authorization from national authorities.

### 20.4 Trademarks

Notice: All referenced brands, product names, service names and trademarks are the property of their respective owners.

**I<sup>2</sup>C-bus** — logo is a trademark of NXP B.V.

## 21. Contact information

For more information, please visit: <http://www.nxp.com>

For sales office addresses, please send an email to: [salesaddresses@nxp.com](mailto:salesaddresses@nxp.com)



22. Tables

|  |    |  |    |
|--|----|--|----|
| Table 1. Ordering information . . . . .  | 2  | (address 12h) bit description . . . . .  | 34 |
| Table 2. Marking codes . . . . .   | 2  | Table 38. Sec_timestp - second timestamp register<br>(address 13h) bit description . . . . . | 34 |
| Table 3. Pin description of PCF2129A . . . . .   | 4  | Table 39. Min_timestp - minute timestamp register<br>(address 14h) bit description . . . . . | 34 |
| Table 4. Register overview . . . . .   | 6  | Table 40. Hour_timestp - hour timestamp register<br>(address 15h) bit description . . . . .  | 35 |
| Table 5. Control_1 - control and status register 1<br>(address 00h) bit description . . . . .          | 8  | Table 41. Day_timestp - day timestamp register<br>(address 16h) bit description . . . . .    | 35 |
| Table 6. Control_2 - control and status register 2<br>(address 01h) bit description . . . . .          | 9  | Table 42. Mon_timestp - month timestamp register<br>(address 17h) bit description . . . . .  | 35 |
| Table 7. Control_3 - control and status register 3<br>(address 0Fh) bit description . . . . .          | 10 | Table 43. Year_timestp - year timestamp register<br>(address 18h) bit description . . . . .  | 35 |
| Table 8. CLKOUT_ctl - CLKOUT control register<br>(address 03h) bit description . . . . .               | 11 | Table 44. Battery switch-over and timestamp . . . . .  | 36 |
| Table 9. Temperature measurement period . . . . .  | 11 | Table 45. Effect of bits MI and SI on pin INT and<br>bit MSF. . . . .                        | 38 |
| Table 10. CLKOUT frequency selection . . . . .   | 12 | Table 46. First increment of time circuits after<br>stop release . . . . .                   | 42 |
| Table 11. Aging_offset - crystal aging offset register<br>(address 19h) bit description . . . . .      | 13 | Table 47. Interface selection input pin IFS. . . . .   | 44 |
| Table 12. Frequency correction at 25 °C, typical . . . . .   | 13 | Table 48. Serial interface . . . . .   | 45 |
| Table 13. Power management control bit description. . . . .  | 14 | Table 49. Command byte definition . . . . .  | 46 |
| Table 14. Output pin BBS. . . . .  | 17 | Table 50. I <sup>2</sup> C slave address byte. . . . .                                       | 49 |
| Table 15. Seconds - seconds and clock integrity<br>register (address 03h) bit description . . . . .    | 22 | Table 51. Limiting values . . . . .  | 51 |
| Table 16. Seconds coded in BCD format . . . . .  | 22 | Table 52. Static characteristics . . . . .   | 52 |
| Table 17. Minutes - minutes register (address 04h)<br>bit description . . . . .                        | 22 | Table 53. Frequency characteristics . . . . .  | 55 |
| Table 18. Hours - hours register (address 05h)<br>bit description . . . . .                            | 23 | Table 54. SPI-bus characteristics . . . . .  | 56 |
| Table 19. Days - days register (address 06h)<br>bit description . . . . .                              | 23 | Table 55. I <sup>2</sup> C-bus characteristics . . . . .                                     | 58 |
| Table 20. Weekdays - weekdays register<br>(address 07h) bit description . . . . .                      | 23 | Table 56. Abbreviations . . . . .  | 61 |
| Table 21. Weekday assignments . . . . .  | 23 | Table 57. Revision history . . . . .   | 63 |
| Table 22. Months - months register (address 08h)<br>bit description . . . . .                          | 24 |  |    |
| Table 23. Month assignments in BCD format. . . . .   | 24 |  |    |
| Table 24. Years - years register (address 09h)<br>bit description . . . . .                            | 24 |  |    |
| Table 25. Second_alarm - second alarm register<br>(address 0Ah) bit description . . . . .              | 27 |  |    |
| Table 26. Minute_alarm - minute alarm register<br>(address 0Bh) bit description . . . . .              | 27 |  |    |
| Table 27. Hour_alarm - hour alarm register<br>(address 0Ch) bit description . . . . .                  | 27 |  |    |
| Table 28. Day_alarm - day rearm register<br>(address 0Dh) bit description . . . . .                    | 28 |  |    |
| Table 29. Weekday_alarm - weekday alarm register<br>(address 0Eh) bit description . . . . .            | 28 |  |    |
| Table 30. Watchdg_tim_ctl - watchdog timer control<br>register (address 10h) bit description . . . . . | 29 |  |    |
| Table 31. Watchdg_tim_val - watchdog timer value<br>register (address 11h) bit description . . . . .   | 29 |  |    |
| Table 32. Programmable watchdog timer. . . . .   | 30 |  |    |
| Table 33. Flag location in register Control_2 . . . . .  | 32 |  |    |
| Table 34. Example values in register Control_2. . . . .  | 32 |  |    |
| Table 35. Example to clear only AF (bit 4) . . . . .   | 32 |  |    |
| Table 36. Example to clear only MSF (bit 7). . . . .   | 32 |  |    |
| Table 37. Timestp_ctl - timestamp control register   |    |  |    |

23. Figures

|   |    |  |  |
|---|----|--|--|
| Fig 1. Block diagram of PCF2129A . . . . .  | 3  |  |  |
| Fig 2. Pin configuration for PCF2129A (SO20) . . . . .  | 4  |  |  |
| Fig 3. Handling address registers . . . . .   | 6  |  |  |
| Fig 4. Battery switch-over behavior in standard mode with bit BIE logic 1 (enabled) . . . . .                                       | 15 |  |  |
| Fig 5. Battery switch-over behavior in direct switching mode with bit BIE logic 1 (enabled) . . . . .                               | 16 |  |  |
| Fig 6. Battery switch-over circuit, simplified block diagram . . . . .  | 17 |  |  |
| Fig 7. Typical driving capability of $V_{BBS}$ : ( $V_{BBS} - V_{DD}$ ) with respect to the output load current $I_{BBS}$ . . . . . | 17 |  |  |
| Fig 8. Battery low detection behavior with bit BLIE logic 1 (enabled) . . . . .   | 18 |  |  |
| Fig 9. Power failure event due to battery discharge: reset occurs . . . . .   | 19 |  |  |
| Fig 10. Dependency between POR and oscillator . . . . .   | 20 |  |  |
| Fig 11. Power-On Reset (POR) system. . . . .  | 20 |  |  |
| Fig 12. Power-On Reset Override (PORO) sequence, valid for both I <sup>2</sup> C-bus and SPI-bus . . . . .                          | 21 |  |  |
| Fig 13. Data flow of the time function. . . . .   | 25 |  |  |
| Fig 14. Access time for read/write operations . . . . .   | 25 |  |  |
| Fig 15. Alarm function block diagram. . . . .   | 26 |  |  |
| Fig 16. Alarm flag timing diagram . . . . .   | 28 |  |  |
| Fig 17. WD_CD set logic 1: watchdog activates an interrupt when timed out . . . . .   | 31 |  |  |
| Fig 18. Timestamp detection with two push-buttons on one the TS pin (e.g. for tamper detection) . . . . .                           | 33 |  |  |
| Fig 19. Interrupt block diagram . . . . .   | 37 |  |  |
| Fig 20. $\overline{INT}$ example for SI and MI when TI_TP is logic 1 . . . . .  | 38 |  |  |
| Fig 21. $\overline{INT}$ example for SI and MI when TI_TP is logic 0 . . . . .  | 39 |  |  |
| Fig 22. Example of shortening the $\overline{INT}$ pulse by clearing the MSF flag. . . . .  | 39 |  |  |
| Fig 23. AF timing diagram . . . . .   | 40 |  |  |
| Fig 24. STOP bit functional diagram . . . . .   | 43 |  |  |
| Fig 25. STOP bit release timing. . . . .  | 43 |  |  |
| Fig 26. Interface selection . . . . .   | 44 |  |  |
| Fig 27. SDI, SDO configurations . . . . .   | 45 |  |  |
| Fig 28. Data transfer overview. . . . .   | 45 |  |  |
| Fig 29. SPI-bus write example. . . . .  | 46 |  |  |
| Fig 30. SPI-bus read example . . . . .  | 46 |  |  |
| Fig 31. Bit transfer . . . . .  | 47 |  |  |
| Fig 32. Definition of START and STOP conditions. . . . .  | 47 |  |  |
| Fig 33. System configuration . . . . .  | 48 |  |  |
| Fig 34. Acknowledgement on the I <sup>2</sup> C-bus . . . . .   | 48 |  |  |
| Fig 35. Bus protocol, writing to registers . . . . .  | 49 |  |  |
| Fig 36. Bus protocol, reading from registers . . . . .  | 49 |  |  |
| Fig 37. Device diode protection diagram of PCF2129A . . . . .   | 50 |  |  |
| Fig 38. $I_{DD}$ as a function of temperature . . . . .   | 53 |  |  |
| Fig 39. $I_{DD}$ as a function of $V_{DD}$ . . . . .  | 54 |  |  |
| Fig 40. Characteristic of frequency with respect to temperature . . . . .   | 55 |  |  |
| Fig 41. SPI-bus timing . . . . .  | 57 |  |  |
| Fig 42. I <sup>2</sup> C-bus timing diagram; rise and fall times refer to 30 % and 70 % . . . . .                                   | 59 |  |  |
| Fig 43. Package outline SOT163-1 (SO20) . . . . .   | 60 |  |  |

## 24. Contents

|          |   |          |           |   |           |
|----------|---|----------|-----------|---|-----------|
| <b>1</b> | <b>General description</b> . . . . .  | <b>1</b> | 8.9.3     | Register Hour_alarm . . . . .                                     | 27        |
| <b>2</b> | <b>Features</b> . . . . .   | <b>1</b> | 8.9.4     | Register Day_alarm . . . . .                                      | 28        |
| <b>3</b> | <b>Applications</b> . . . . .   | <b>2</b> | 8.9.5     | Register Weekday_alarm . . . . .                                  | 28        |
| <b>4</b> | <b>Ordering information</b> . . . . .   | <b>2</b> | 8.9.6     | Alarm flag . . . . .  | 28        |
| <b>5</b> | <b>Marking</b> . . . . .  | <b>2</b> | 8.10      | Timer functions . . . . .   | 29        |
| <b>6</b> | <b>Block diagram</b> . . . . .  | <b>3</b> | 8.10.1    | Register Watchdg_tim_ctl . . . . .                                | 29        |
| <b>7</b> | <b>Pinning information</b> . . . . .  | <b>4</b> | 8.10.2    | Register Watchdg_tim_val . . . . .                                | 29        |
| 7.1      | Pinning . . . . .   | 4        | 8.10.3    | Watchdog timer function . . . . .                                 | 30        |
| 7.2      | Pin description . . . . .   | 4        | 8.10.4    | Pre-defined timers: second and<br>minute interrupt . . . . .      | 31        |
| <b>8</b> | <b>Functional description</b> . . . . .   | <b>5</b> | 8.10.5    | Clearing flags . . . . .  | 31        |
| 8.1      | Register overview . . . . .   | 5        | 8.11      | Timestamp function . . . . .                                      | 33        |
| 8.2      | Control registers . . . . .   | 8        | 8.11.1    | Timestamp flag . . . . .  | 33        |
| 8.2.1    | Register Control_1 . . . . .  | 8        | 8.11.2    | Timestamp mode . . . . .  | 34        |
| 8.2.2    | Register Control_2 . . . . .  | 9        | 8.11.3    | Timestamp registers . . . . .                                     | 34        |
| 8.2.3    | Register Control_3 . . . . .  | 10       | 8.11.3.1  | Register Timestp_ctl . . . . .                                    | 34        |
| 8.3      | Register CLKOUT_ctl . . . . .   | 11       | 8.11.3.2  | Register Sec_timestp . . . . .                                    | 34        |
| 8.3.1    | Temperature compensated crystal<br>oscillator . . . . .                             | 11       | 8.11.3.3  | Register Min_timestp . . . . .                                    | 34        |
| 8.3.1.1  | Temperature measurement . . . . .   | 11       | 8.11.3.4  | Register Hour_timestp . . . . .                                   | 35        |
| 8.3.2    | Clock output . . . . .  | 11       | 8.11.3.5  | Register Day_timestp . . . . .                                    | 35        |
| 8.4      | Register Aging_offset . . . . .   | 13       | 8.11.3.6  | Register Mon_timestp . . . . .                                    | 35        |
| 8.4.1    | Crystal aging correction . . . . .  | 13       | 8.11.3.7  | Register Year_timestp . . . . .                                   | 35        |
| 8.5      | Power management functions . . . . .  | 14       | 8.11.4    | Dependency between Battery<br>switch-over and timestamp . . . . . | 36        |
| 8.5.1    | Battery switch-over function . . . . .  | 14       | 8.12      | Interrupt output, INT . . . . .                                   | 37        |
| 8.5.1.1  | Standard mode . . . . .   | 15       | 8.12.1    | Minute and second interrupts . . . . .                            | 38        |
| 8.5.1.2  | Direct switching mode . . . . .   | 15       | 8.12.2    | INT pulse shortening . . . . .                                    | 39        |
| 8.5.1.3  | Battery switch-over disabled: only<br>one power supply (V <sub>DD</sub> ) . . . . . | 16       | 8.12.3    | Watchdog timer interrupts . . . . .                               | 39        |
| 8.5.1.4  | Battery switch-over architecture . . . . .  | 16       | 8.12.4    | Alarm interrupts . . . . .  | 40        |
| 8.5.2    | Battery backup supply . . . . .   | 17       | 8.12.5    | Timestamp interrupts . . . . .                                    | 40        |
| 8.5.3    | Battery low detection function . . . . .  | 18       | 8.12.6    | Battery switch-over interrupts . . . . .                          | 40        |
| 8.6      | Oscillator stop detection function . . . . .  | 19       | 8.12.7    | Battery low detection interrupts . . . . .                        | 40        |
| 8.7      | Reset function . . . . .  | 20       | 8.13      | External clock test mode . . . . .                                | 41        |
| 8.7.1    | Power-On Reset (POR) . . . . .  | 20       | 8.14      | STOP bit function . . . . .                                       | 42        |
| 8.7.2    | Power-On Reset Override (PORO) . . . . .  | 20       | <b>9</b>  | <b>Interfaces</b> . . . . .                                       | <b>44</b> |
| 8.8      | Time and date function . . . . .  | 22       | 9.1       | SPI-bus interface . . . . .                                       | 45        |
| 8.8.1    | Register Seconds . . . . .  | 22       | 9.1.1     | Data transmission . . . . .                                       | 45        |
| 8.8.2    | Register Minutes . . . . .  | 22       | 9.2       | I <sup>2</sup> C-bus interface . . . . .                          | 47        |
| 8.8.3    | Register Hours . . . . .  | 23       | 9.2.1     | Bit transfer . . . . .  | 47        |
| 8.8.4    | Register Days . . . . .   | 23       | 9.2.2     | START and STOP conditions . . . . .                               | 47        |
| 8.8.5    | Register Weekdays . . . . .   | 23       | 9.2.3     | System configuration . . . . .                                    | 47        |
| 8.8.6    | Register Months . . . . .   | 24       | 9.2.4     | Acknowledge . . . . .   | 48        |
| 8.8.7    | Register Years . . . . .  | 24       | 9.2.5     | I <sup>2</sup> C-bus protocol . . . . .                           | 48        |
| 8.8.8    | Setting and reading the time . . . . .  | 25       | <b>10</b> | <b>Internal circuitry</b> . . . . .                               | <b>50</b> |
| 8.9      | Alarm function . . . . .  | 26       | <b>11</b> | <b>Limiting values</b> . . . . .                                  | <b>51</b> |
| 8.9.1    | Register Second_alarm . . . . .   | 27       | <b>12</b> | <b>Static characteristics</b> . . . . .                           | <b>52</b> |
| 8.9.2    | Register Minute_alarm . . . . .   | 27       |           |   |           |

continued &gt;&gt;

12.1 Current consumption  $I_{DD}$  characteristics, typical . . . . . 53

12.2 Frequency characteristics . . . . . 55

**13 Dynamic characteristics . . . . . 56**

13.1 SPI-bus timing characteristics . . . . . 56

13.2 I<sup>2</sup>C-bus timing characteristics . . . . . 58

**14 Application information . . . . . 59**

**15 Package outline . . . . . 60**

**16 Soldering . . . . . 61**

**17 Abbreviations . . . . . 61**

**18 References . . . . . 62**

**19 Revision history . . . . . 63**

**20 Legal information . . . . . 64**

20.1 Data sheet status . . . . . 64

20.2 Definitions . . . . . 64

20.3 Disclaimers . . . . . 64

20.4 Trademarks . . . . . 64

**21 Contact information . . . . . 64**

**22 Tables . . . . . 65**

**23 Figures . . . . . 66**

**24 Contents . . . . . 67**



Please be aware that important notices concerning this document and the product(s) described herein, have been included in section 'Legal information'.

© NXP B.V. 2010.

All rights reserved.

For more information, please visit: <http://www.nxp.com>

For sales office addresses, please send an email to: [salesaddresses@nxp.com](mailto:salesaddresses@nxp.com)

Date of release: 13 January 2010

Document identifier: PCF2129A\_1