

# CAT24WC01/02/04/08/16

## 1K/2K/4K/8K/16K-Bit Serial EEPROM

### FEATURES

- 400 kHz I<sup>2</sup>C Bus Compatible\*
  - 1.8 to 5.5Volt Operation
  - Low Power CMOS Technology
  - Write Protect Feature
    - Entire Array Protected When WP at V<sub>IH</sub>
  - Page Write Buffer
- Self-Timed Write Cycle with Auto-Clear
  - 1,000,000 Program/Erase Cycles
  - 100 Year Data Retention
  - 8-pin DIP, SOIC, TSSOP and MSOP packages
    - "Green" package option available
  - Commercial, Industrial, Automotive and Extended Temperature Ranges

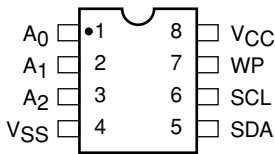
### DESCRIPTION

The CAT24WC01/02/04/08/16 is a 1K/2K/4K/8K/16K-bit Serial CMOS EEPROM internally organized as 128/256/512/1024/2048 words of 8 bits each. Catalyst's advanced CMOS technology substantially reduces device power requirements. The the CAT24WC01/02/04/

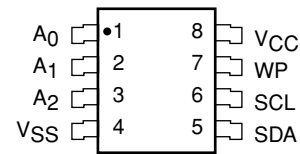
08/16 feature a 16-byte page write buffer. The device operates via the I<sup>2</sup>C bus serial interface, has a special write protection feature, and is available in 8-pin DIP, SOIC, TSSOP and MSOP packages.

### PIN CONFIGURATION

#### DIP Package (P, L, GL)



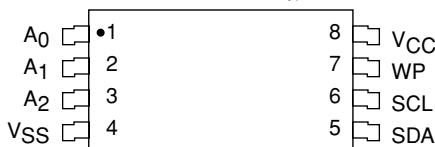
#### SOIC Package (J, W, GW)



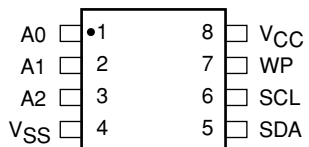
5020 FHD F01

#### TSSOP Package (U, Y, GY)

(MSOP and TSSOP available for CAT24WC01, CAT24WC02 and CAT24WC04 only)



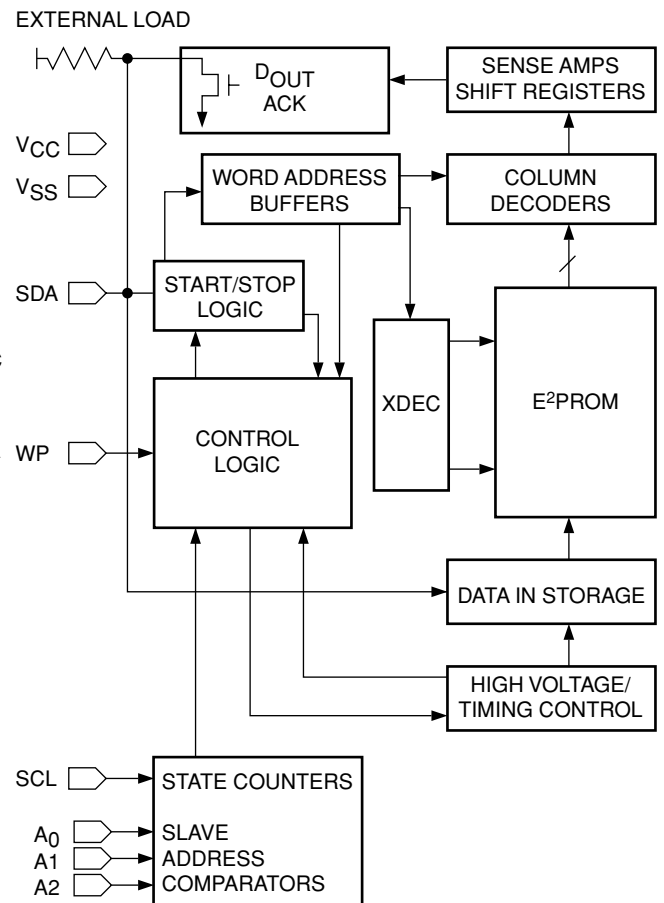
#### MSOP Package (R, Z, GZ)



### PIN FUNCTIONS

Pin Name	Function
A0, A1, A2	Device Address Inputs
SDA	Serial Data/Address
SCL	Serial Clock
WP	Write Protect
V <sub>CC</sub>	+1.8V to +5.5V Power Supply
V <sub>SS</sub>	Ground

### BLOCK DIAGRAM



\* Catalyst Semiconductor is licensed by Philips Corporation to carry the I<sup>2</sup>C Bus Protocol.

**ABSOLUTE MAXIMUM RATINGS\***

Temperature Under Bias .....	-55°C to +125°C
Storage Temperature .....	-65°C to +150°C
Voltage on Any Pin with Respect to Ground <sup>(1)</sup> .....	-2.0V to +V <sub>CC</sub> + 2.0V
V <sub>CC</sub> with Respect to Ground .....	-2.0V to +7.0V
Package Power Dissipation Capability (T <sub>a</sub> = 25°C) .....	1.0W
Lead Soldering Temperature (10 secs) .....	300°C
Output Short Circuit Current <sup>(2)</sup> .....	100mA

**\*COMMENT**

Stresses above those listed under “Absolute Maximum Ratings” may cause permanent damage to the device. These are stress ratings only, and functional operation of the device at these or any other conditions outside of those listed in the operational sections of this specification is not implied. Exposure to any absolute maximum rating for extended periods may affect device performance and reliability.

**RELIABILITY CHARACTERISTICS**

Symbol	Parameter	Min.	Max.	Units
N <sub>END</sub> <sup>(3)</sup>	Endurance	1,000,000		Cycles/Byte
T <sub>DR</sub> <sup>(3)</sup>	Data Retention	100		Years
V <sub>ZAP</sub> <sup>(3)</sup>	ESD Susceptibility	2000		Volts
I <sub>LTH</sub> <sup>(3)(4)</sup>	Latch-up	100		mA

**D.C. OPERATING CHARACTERISTICS**

V<sub>CC</sub> = +1.8V to +5.5V, unless otherwise specified.

Symbol	Parameter	Limits			Units	Test Conditions
		Min.	Typ.	Max.		
I <sub>CC</sub>	Power Supply Current			3	mA	f <sub>SCL</sub> = 100 KHz
I <sub>SB</sub> <sup>(5)</sup>	Standby Current (V <sub>CC</sub> = 5.0V)			1	μA	V <sub>IN</sub> = GND or V <sub>CC</sub>
I <sub>LI</sub>	Input Leakage Current			10	μA	V <sub>IN</sub> = GND to V <sub>CC</sub>
I <sub>LO</sub>	Output Leakage Current			10	μA	V <sub>OUT</sub> = GND to V <sub>CC</sub>
V <sub>IL</sub>	Input Low Voltage	-1		V <sub>CC</sub> × 0.3	V	
V <sub>IH</sub>	Input High Voltage	V <sub>CC</sub> × 0.7		V <sub>CC</sub> + 0.5	V	
V <sub>OL1</sub>	Output Low Voltage (V <sub>CC</sub> = 3.0V)			0.4	V	I <sub>OL</sub> = 3 mA
V <sub>OL2</sub>	Output Low Voltage (V <sub>CC</sub> = 1.8V)			0.5	V	I <sub>OL</sub> = 1.5 mA

**CAPACITANCE** T<sub>A</sub> = 25°C, f = 1.0 MHz, V<sub>CC</sub> = 5V

Symbol	Test	Max.	Units	Conditions
C <sub>I/O</sub> <sup>(3)</sup>	Input/Output Capacitance (SDA)	8	pF	V <sub>I/O</sub> = 0V
C <sub>IN</sub> <sup>(3)</sup>	Input Capacitance (A0, A1, A2, SCL, WP)	6	pF	V <sub>IN</sub> = 0V

Note:

- (1) The minimum DC input voltage is -0.5V. During transitions, inputs may undershoot to -2.0V for periods of less than 20 ns. Maximum DC voltage on output pins is V<sub>CC</sub> + 0.5V, which may overshoot to V<sub>CC</sub> + 2.0V for periods of less than 20ns.
- (2) Output shorted for no more than one second. No more than one output shorted at a time.
- (3) These parameters are tested initially and after a design or process change that affects the parameter according to appropriate AEC-Q100 and JEDEC test methods.
- (4) Latch-up protection is provided for stresses up to 100 mA on address and data pins from -1V to V<sub>CC</sub> + 1V.
- (5) Maximum standby current (I<sub>SB</sub>) = 10μA for the Automotive and Extended Automotive temperature range.

**A.C. CHARACTERISTICS**
 $V_{CC} = +1.8V$  to  $+5.5V$ , unless otherwise specified.

**Read & Write Cycle Limits**

Symbol	Parameter	CAT24WCXX-1.8		CAT24WCXX				Units
		1.8V-5.5V		2.5V-5.5V		4.5V-5.5V		
		Min.	Max.	Min.	Max.	Min.	Max.	
$F_{SCL}$	Clock Frequency		100		100		400	kHz
$T_I^{(1)}$	Noise Suppression Time Constant at SCL, SDA Inputs		200		200		200	ns
$t_{AA}$	SCL Low to SDA Data Out and ACK Out		3.5		3.5		1	$\mu$ s
$t_{BUF}^{(1)}$	Time the Bus Must be Free Before a New Transmission Can Start	4.7		4.7		1.2		$\mu$ s
$t_{HD:STA}$	Start Condition Hold Time	4		4		0.6		$\mu$ s
$t_{LOW}$	Clock Low Period	4.7		4.7		1.2		$\mu$ s
$t_{HIGH}$	Clock High Period	4		4		0.6		$\mu$ s
$t_{SU:STA}$	Start Condition Setup Time (for a Repeated Start Condition)	4.7		4.7		0.6		$\mu$ s
$t_{HD:DAT}$	Data In Hold Time	0		0		0		ns
$t_{SU:DAT}$	Data In Setup Time	50		50		50		ns
$t_R^{(1)}$	SDA and SCL Rise Time		1		1		0.3	$\mu$ s
$t_F^{(1)}$	SDA and SCL Fall Time		300		300		300	ns
$t_{SU:STO}$	Stop Condition Setup Time	4		4		0.6		$\mu$ s
$t_{DH}$	Data Out Hold Time	100		100		100		ns

**Power-Up Timing(1)(2)**

Symbol	Parameter	Max.	Units
$t_{PUR}$	Power-up to Read Operation	1	ms
$t_{PUW}$	Power-up to Write Operation	1	ms

**Write Cycle Limits**

Symbol	Parameter	Min.	Typ.	Max	Units
$t_{WR}$	Write Cycle Time			10	ms

The write cycle time is the time from a valid stop condition of a write sequence to the end of the internal program/erase cycle. During the write cycle, the bus

interface circuits are disabled, SDA is allowed to remain high, and the device does not respond to its slave address.

Note:

- (1) This parameter is tested initially and after a design or process change that affects the parameter.
- (2)  $t_{PUR}$  and  $t_{PUW}$  are the delays required from the time  $V_{CC}$  is stable until the specified operation can be initiated.

## FUNCTIONAL DESCRIPTION

The CAT24WC01/02/04/08/16 supports the I<sup>2</sup>C Bus data transmission protocol. This Inter-Integrated Circuit Bus protocol defines any device that sends data to the bus to be a transmitter and any device receiving data to be a receiver. Data transfer is controlled by the Master device which generates the serial clock and all START and STOP conditions for bus access. The CAT24WC01/02/04/08/16 operates as a Slave device. Both the Master and Slave devices can operate as either transmitter or receiver, but the Master device controls which mode is activated. A maximum of 8 devices (CAT24WC01 and CAT24WC02), 4 devices (CAT24WC04), 2 devices (CAT24WC08) and 1 device (CAT24WC16) may be connected to the bus as determined by the device address inputs A0, A1, and A2.

## PIN DESCRIPTIONS

**SCL:** Serial Clock

The CAT24WC01/02/04/08/16 serial clock input pin is used to clock all data transfers into or out of the device. This is an input pin.

**SDA:** Serial Data/Address

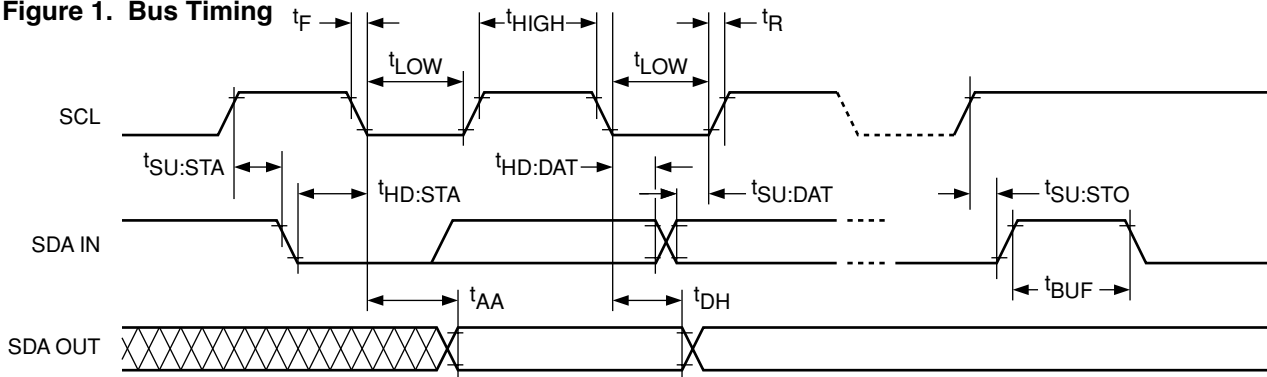
The CAT24WC01/02/04/08/16 bidirectional serial data/address pin is used to transfer data into and out of the device. The SDA pin is an open drain output and can be wire-ORed with other open drain or open collector outputs.

**A0, A1, A2:** Device Address Inputs

These inputs set device address when cascading multiple devices. When these pins are left floating the default values are zeros.

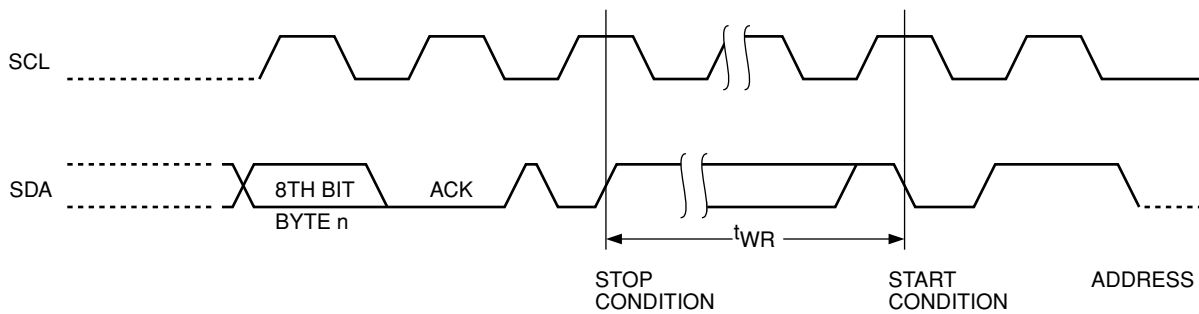
A maximum of eight devices can be cascaded when

**Figure 1. Bus Timing**



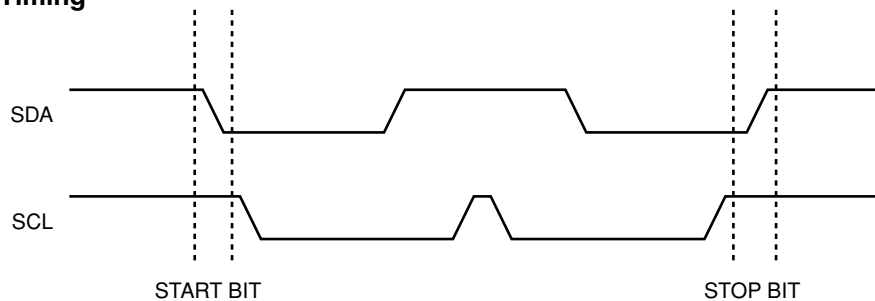
5020 FHD F03

**Figure 2. Write Cycle Timing**



5020 FHD F04

**Figure 3. Start/Stop Timing**



5020 FHD F05

using either CAT24WC01 or CAT24WC02 device. All three address pins are used for these densities. If only one CAT24WC01 or CAT24WC02 is addressed on the bus, all three address pins (A0, A1 and A2) can be left floating or connected to V<sub>SS</sub>.

A total of four devices can be addressed on a single bus when using CAT24WC04 device. Only A1 and A2 address pins are used with this device. The A0 address pin is a no connect pin and can be tied to V<sub>SS</sub> or left floating. If only one CAT24WC04 is being addressed on the bus, the address pins (A1 and A2) can be left floating or connected to V<sub>SS</sub>.

Only two devices can be cascaded when using CAT24WC08. The only address pin used with this device is A2. The A0 and A1 address pins are no connect pins and can be tied to V<sub>SS</sub> or left floating. If only one CAT24WC08 is being addressed on the bus, the address pin (A2) can be left floating or connected to V<sub>SS</sub>.

The CAT24WC16 is a stand alone device. In this case, all address pins (A0, A1 and A2) are no connect pins and can be tied to V<sub>SS</sub> or left floating.

**WP: Write Protect**

If the WP pin is tied to V<sub>CC</sub> the entire memory array becomes Write Protected (READ only). When the WP pin is tied to V<sub>SS</sub> or left floating normal read/write operations are allowed to the device.

**I<sup>2</sup>C Bus Protocol**

The following defines the features of the I<sup>2</sup>C bus protocol:

- (1) Data transfer may be initiated only when the bus is not busy.
- (2) During a data transfer, the data line must remain

stable whenever the clock line is high. Any changes in the data line while the clock line is high will be interpreted as a START or STOP condition.

**START Condition**

The START Condition precedes all commands to the device, and is defined as a HIGH to LOW transition of SDA when SCL is HIGH. The CAT24WC01/02/04/08/16 monitor the SDA and SCL lines and will not respond until this condition is met.

**STOP Condition**

A LOW to HIGH transition of SDA when SCL is HIGH determines the STOP condition. All operations must end with a STOP condition.

**DEVICE ADDRESSING**

The bus Master begins a transmission by sending a START condition. The Master then sends the address of the particular slave device it is requesting. The four most significant bits of the 8-bit slave address are fixed as 1010 for the CAT24WC01/02/04/08/16 (see Fig. 5). The next three significant bits (A2, A1, A0) are the device address bits and define which device or which part of the device the Master is accessing. Up to eight CAT24WC01/02, four CAT24WC04, two CAT24WC08, and one CAT24WC16 may be individually addressed by the system. The last bit of the slave address specifies whether a Read or Write operation is to be performed. When this bit is set to 1, a Read operation is selected, and when set to 0, a Write operation is selected.

After the Master sends a START condition and the slave address byte, the CAT24WC01/02/04/08/16 monitors the bus and responds with an acknowledge (on the SDA line) when its address matches the transmitted slave

**Figure 4. Acknowledge Timing**

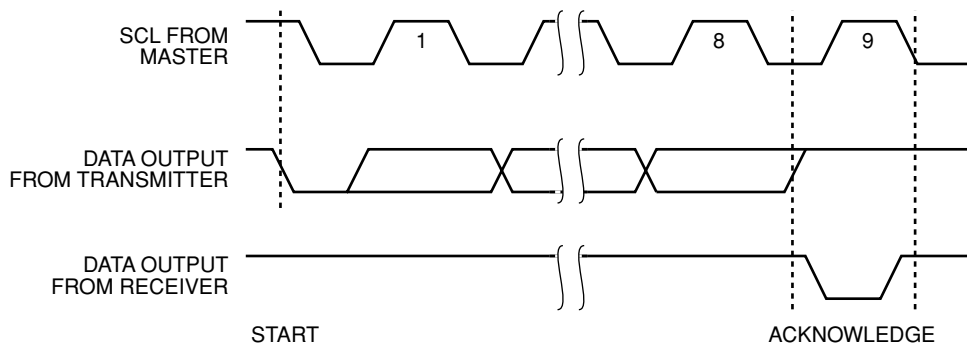
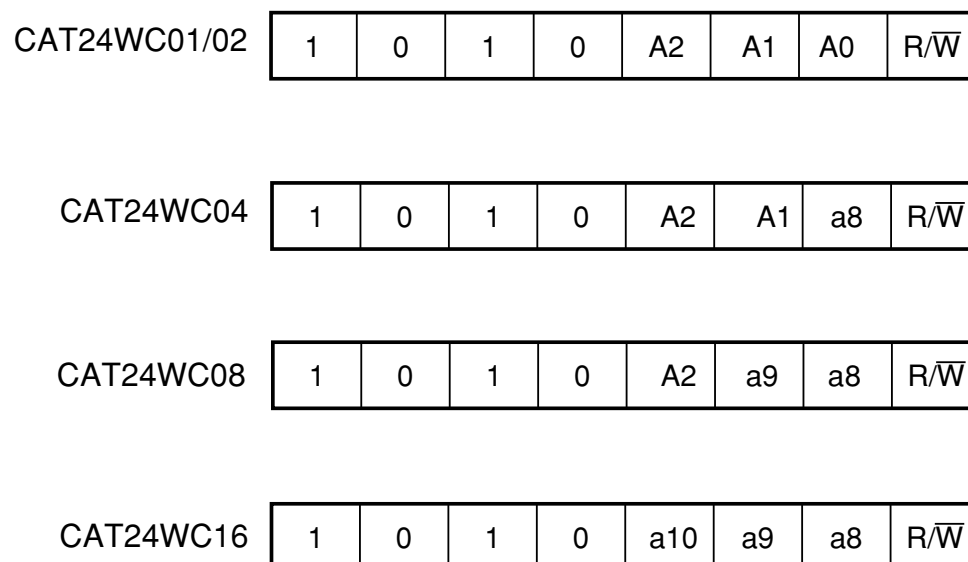


Figure 5. Slave Address Bits



\* A0, A1 and A2 correspond to pin 1, pin 2 and pin 3 of the device.

\*\* a8, a9 and a10 correspond to the address of the memory array address word.

\*\*\* A0, A1 and A2 must compare to its corresponding hard wired input pins (pins 1, 2 and 3).

address. The CAT24WC01/02/04/08/16 then performs a Read or Write operation depending on the state of the R/ $\overline{W}$  bit.

### Acknowledge

After a successful data transfer, each receiving device is required to generate an acknowledge. The Acknowledging device pulls down the SDA line during the ninth clock cycle, signaling that it received the 8 bits of data.

The CAT24WC01/02/04/08/16 responds with an acknowledge after receiving a START condition and its slave address. If the device has been selected along with a write operation, it responds with an acknowledge after receiving each 8-bit byte.

When the CAT24WC01/02/04/08/16 is in a READ mode it transmits 8 bits of data, releases the SDA line, and monitors the line for an acknowledge. Once it receives this acknowledge, the CAT24WC01/02/04/08/16 will continue to transmit data. If no acknowledge is sent by the Master, the device terminates data transmission and waits for a STOP condition.

## WRITE OPERATIONS

### Byte Write

In the Byte Write mode, the Master device sends the START condition and the slave address information (with the R/ $\overline{W}$  bit set to zero) to the Slave device. After the Slave generates an acknowledge, the Master sends the byte address that is to be written into the address pointer of the CAT24WC01/02/04/08/16. After receiving another acknowledge from the Slave, the Master device transmits the data byte to be written into the addressed memory location. The CAT24WC01/02/04/08/16 acknowledge once more and the Master generates the STOP condition, at which time the device begins its internal programming cycle to nonvolatile memory. While this internal cycle is in progress, the device will not respond to any request from the Master device.

### Page Write

The CAT24WC01/02/04/08/16 writes up to 16 bytes of data in a single write cycle, using the Page Write operation. The Page Write operation is initiated in the same manner as the Byte Write operation, however instead of terminating after the initial word is transmitted,

the Master is allowed to send up to fifteen additional bytes. After each byte has been transmitted the CAT24WC01/02/04/08/16 will respond with an acknowledge, and internally increment the low order address bits by one. The high order bits remain unchanged.

If the Master transmits more than sixteen bytes prior to sending the STOP condition, the address counter 'wraps around', and previously transmitted data will be overwritten.

Once all sixteen bytes are received and the STOP condition has been sent by the Master, the internal programming cycle begins. At this point all received data is written to the CAT24WC01/02/04/08/16 in a single write cycle.

**Acknowledge Polling**

The disabling of the inputs can be used to take advantage of the typical write cycle time. Once the stop condition is issued to indicate the end of the host's write operation, the CAT24WC01/02/04/08/16 initiates the internal write cycle. ACK polling can be initiated immediately. This involves issuing the start condition followed by the slave address for a write operation. If the CAT24WC01/02/04/08/16 is still busy with the write operation, no ACK will be returned. If the CAT24WC01/02/04/08/16 has completed the write operation, an ACK will be returned and the host can then proceed with the next read or write operation.

**WRITE PROTECTION**

The Write Protection feature allows the user to protect against inadvertent programming of the memory array. If the WP pin is tied to V<sub>CC</sub>, the entire memory array is protected and becomes read only. The CAT24WC01/02/04/08/16 will accept both slave and byte addresses, but the memory location accessed is protected from programming by the device's failure to send an acknowledge after the first byte of data is received.

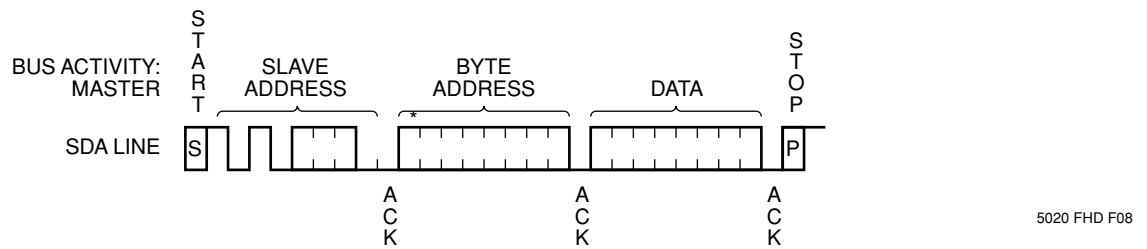
**READ OPERATIONS**

The READ operation for the CAT24WC01/02/04/08/16 is initiated in the same manner as the write operation with the one exception that the R/W bit is set to a one. Three different READ operations are possible: Immediate Address READ, Selective READ and Sequential READ.

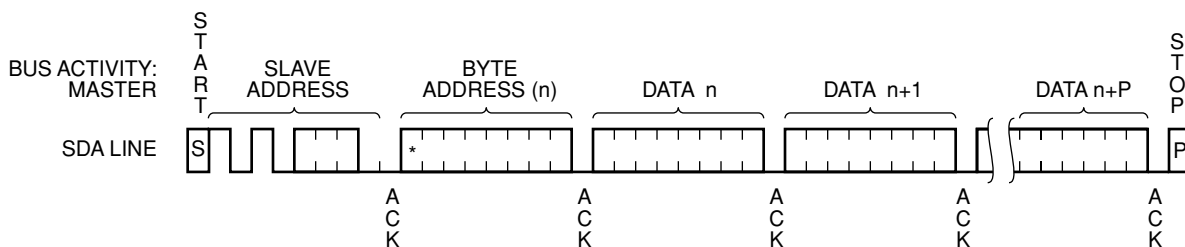
**Immediate Address Read**

The CAT24WC01/02/04/08/16's address counter contains the address of the last byte accessed, incremented by one. In other words, if the last READ or WRITE access was to address N, the READ immediately following would access data from address N+1. If N=E (where E = 255 for 24WC02, 511 for 24WC04, 1023 for 24WC08, and 2047 for 24WC16), then the counter will 'wrap around' to address 0 and continue to clock out data. If N = E (where E = 127 for the CAT24WC01) the counter will not 'wrap around'.

**Figure 6. Byte Write Timing**



**Figure 7. Page Write Timing**



NOTE: IN THIS EXAMPLE n = XXXX 0000(B); X = 1 or 0

P=7 for CAT24WC01 and P=15 for CAT24WC02/04/08/16

\* = Don't care for CAT24WC01

24WCXX F09

**Selective Read**

Selective READ operations allow the Master device to select at random any memory location for a READ operation. The Master device first performs a 'dummy' write operation by sending the START condition, slave address and byte address of the location it wishes to read. After the CAT24WC01/02/04/08/16 acknowledge the word address, the Master device resends the START condition and the slave address, this time with the R/W bit set to one. The CAT24WC01/02/04/08/16 then responds with its acknowledge and sends the 8-bit byte requested. The master device does not send an acknowledge but will generate a STOP condition.

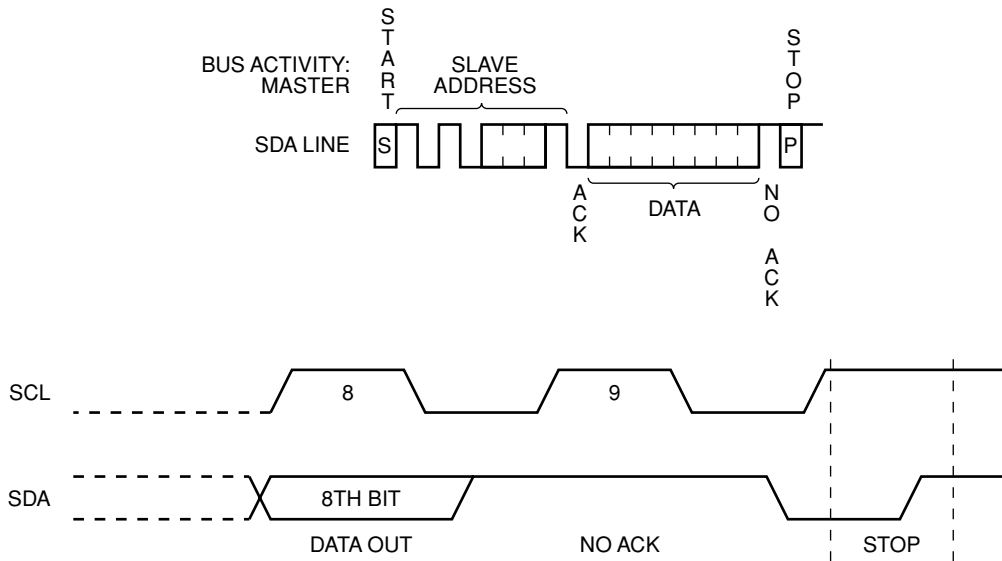
operations. After the 24WC01/02/04/08/16 sends initial 8-bit byte requested, the Master will respond with an acknowledge which tells the device it requires more data. The CAT24WC01/02/04/08/16 will continue to output an 8-bit byte for each acknowledge sent by the Master. The operation is terminated when the Master fails to respond with an acknowledge, thus sending the STOP condition.

**Sequential Read**

The Sequential READ operation can be initiated by either the immediate Address READ or Selective READ

The data being transmitted from the CAT24WC01/02/04/08/16 is outputted sequentially with data from address N followed by data from address N+1. The READ operation address counter increments all of the CAT24WC01/02/04/08/16 address bits so that the entire memory array can be read during one operation. If more than the E (where E = 255 for 24WC02, 511 for 24WC04, 1023 for 24WC08, and 2047 for 24WC16) bytes are read out, the counter will "wrap around" and continue to clock out data bytes. If N = E (where E = 127 for the CAT24WC01) the counter will not 'wrap around'.

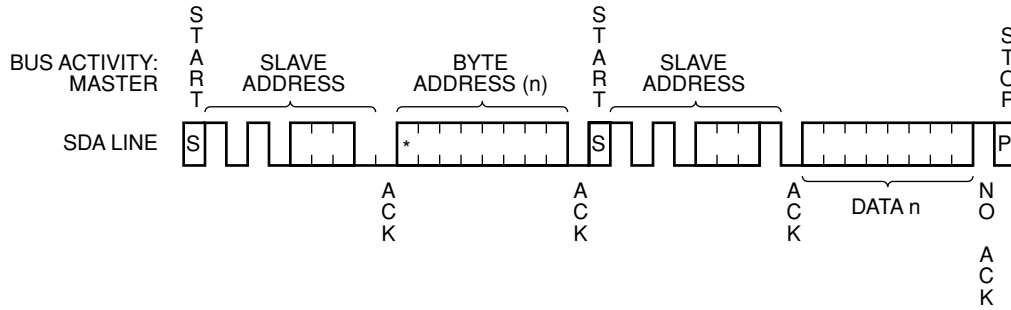
**Figure 8. Immediate Address Read Timing**



5020 FHD F10

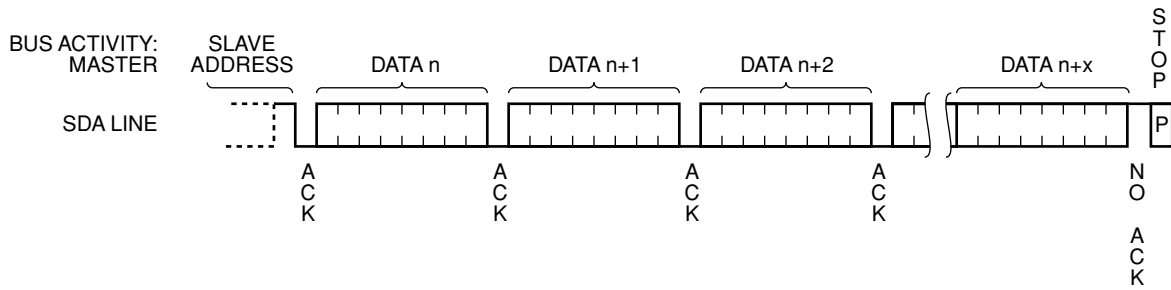


Figure 9. Selective Read Timing



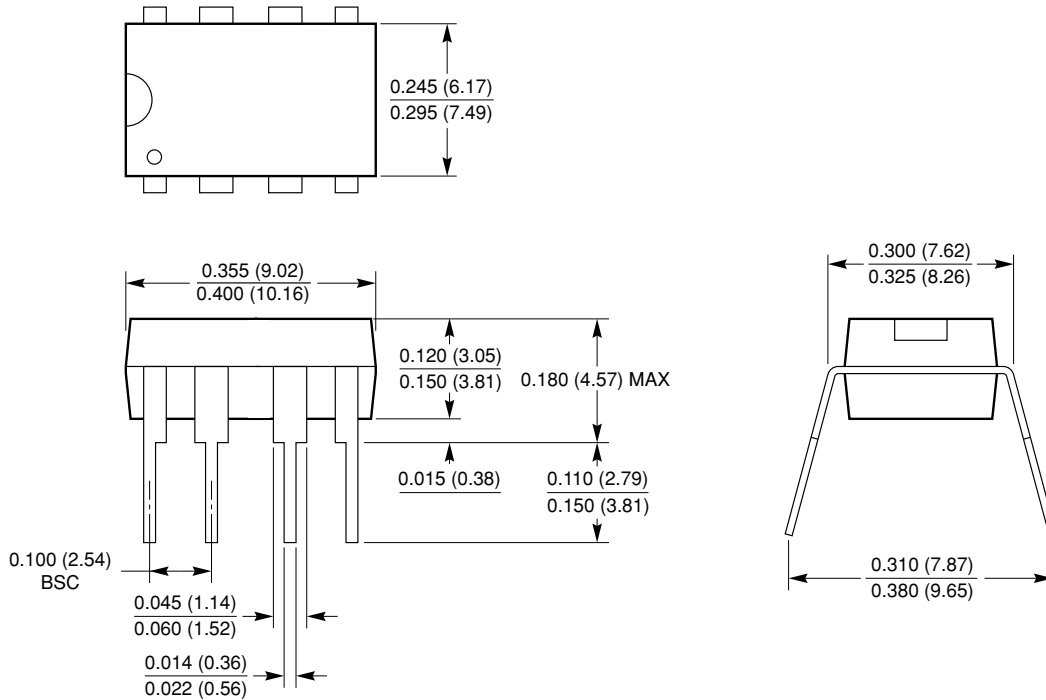
24WCXX F11

Figure 10. Sequential Read Timing



5020 FHD F12

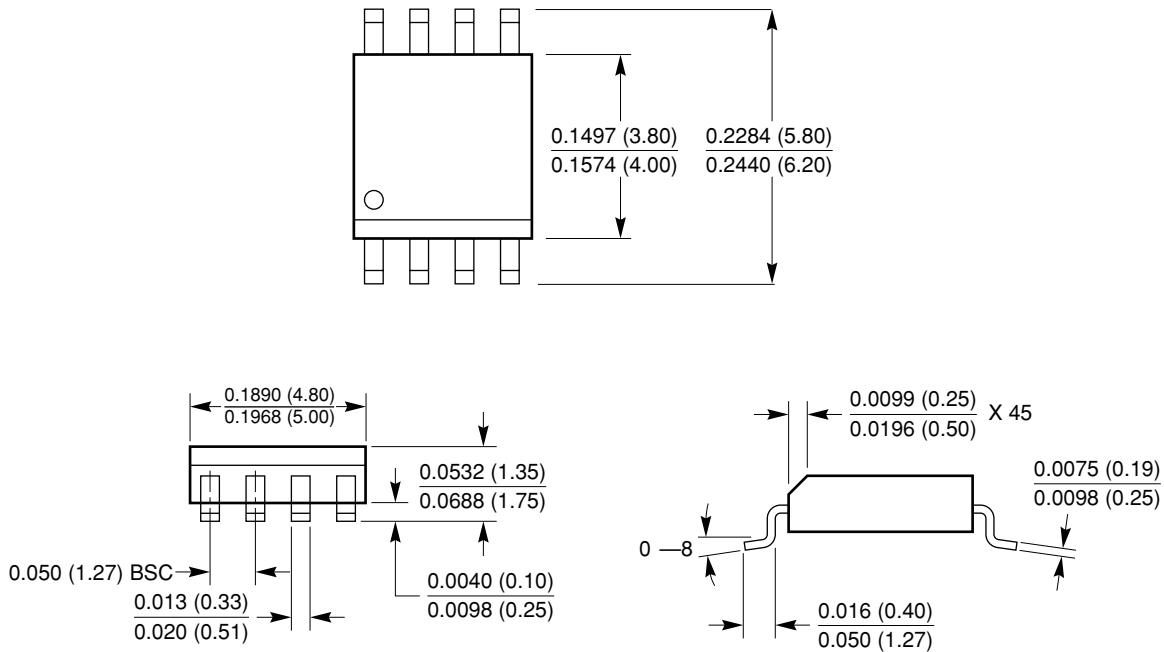
### 8-LEAD 300 MIL WIDE PLASTIC DIP (P, L, GL)



Notes:

1. Complies with JEDEC Publication 95 MS001 dimensions; however, some of the dimensions may be more stringent.
2. All linear dimensions are in inches and parenthetically in millimeters.

### 8-LEAD 150 MIL WIDE SOIC (J, W, GW)

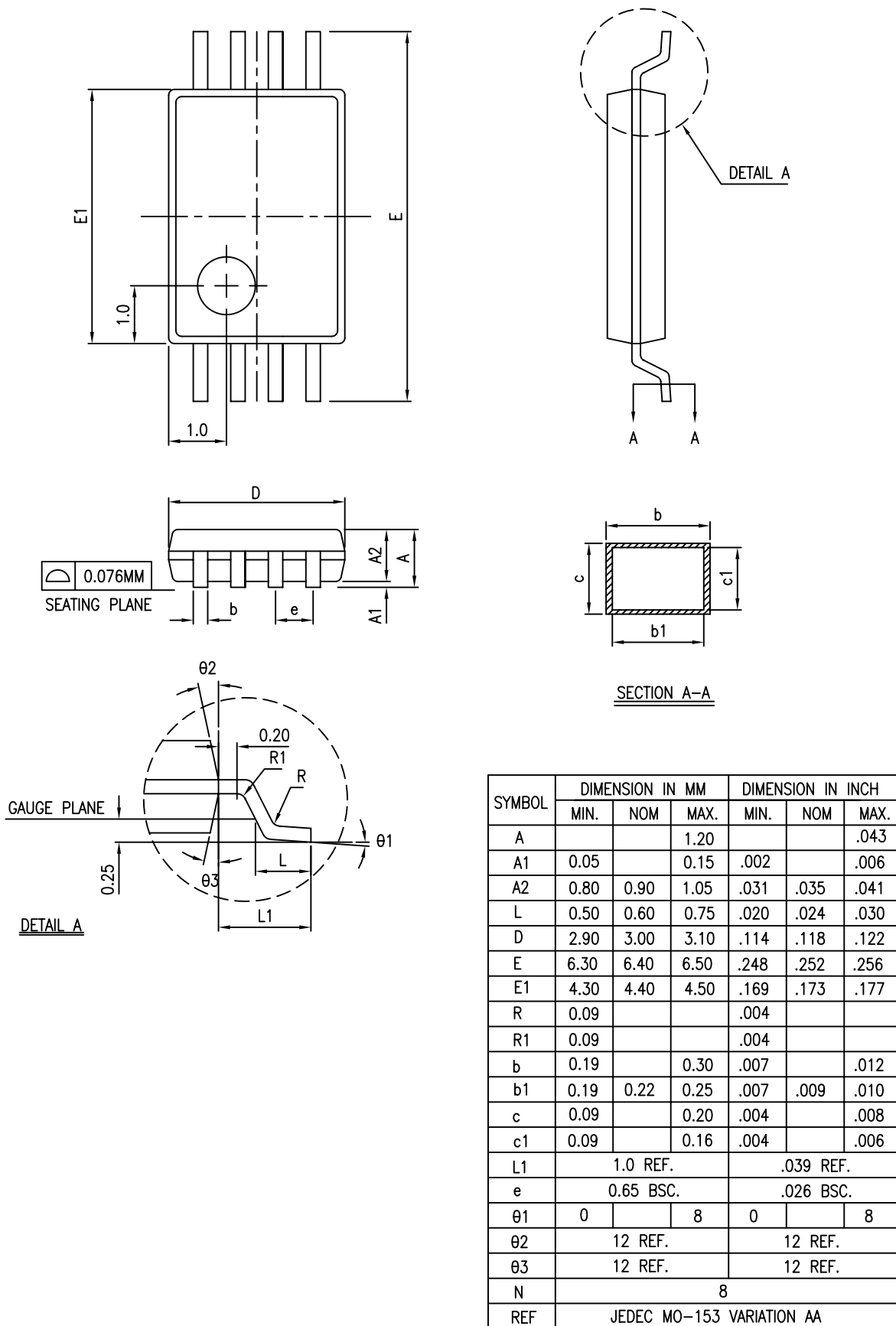


Notes:

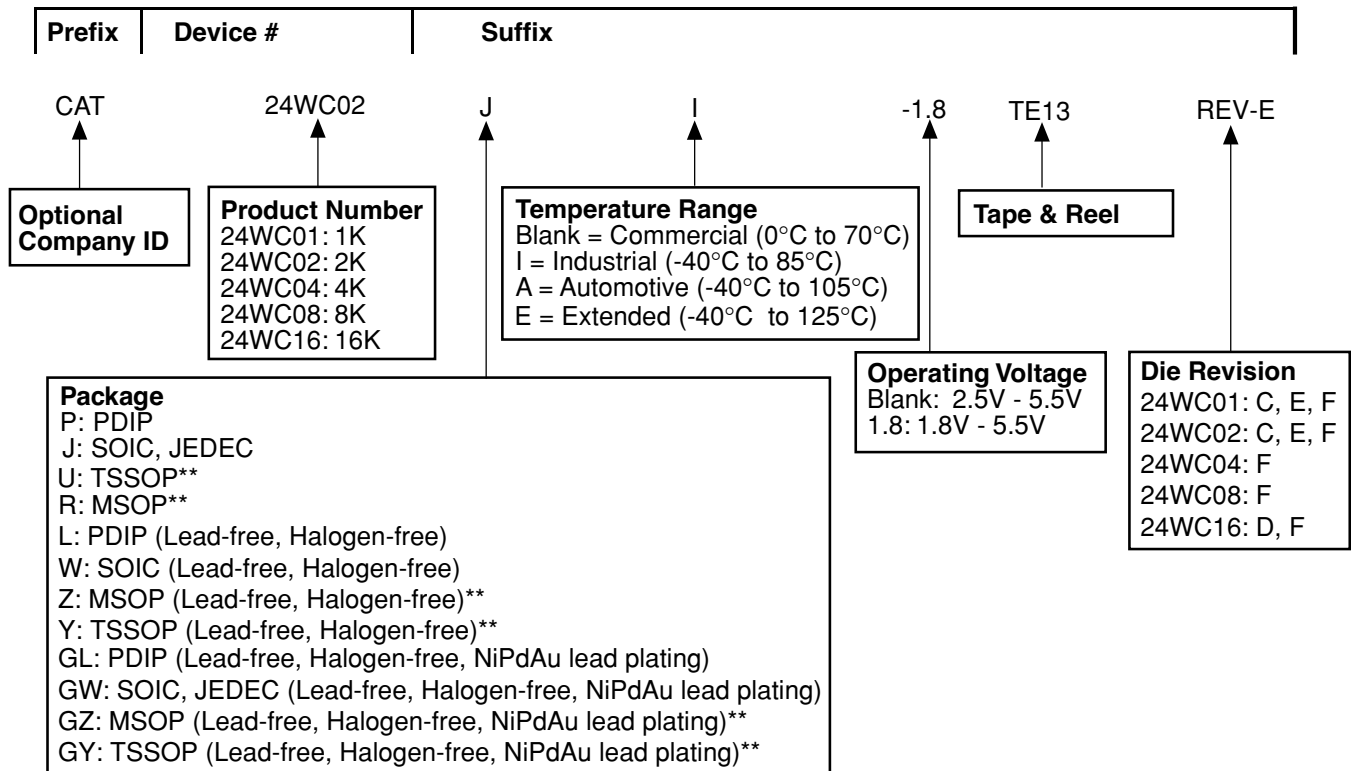
1. Complies with JEDEC publication 95 MS-012 dimensions; however, some dimensions may be more stringent.
2. All linear dimensions are in inches and parenthetically in millimeters.



**8-LEAD TSSOP (U, Y, GY)**



**ORDERING INFORMATION**



\*\* Available for CAT24WC01, CAT24WC02 and CAT24WC04

Notes:

- (1) The device used in the above example is a CAT24WC02JI-1.8TE13REV-E (SOIC, Industrial Temperature, 1.8 Volt to 5.5 Volt Operating Voltage, Tape & Reel, Die Revision E)

## REVISION HISTORY

Date	Rev.	Reason
2/3/2004	H	Added: CAT24WC01/02/16 not recommended for new designs. See CAT24FC01, CAT24FC02 and CAT24FC16 data sheets
5/28/2004	I	Added Die Revision to ordering information
7/28/2004	J	Update DC operating characteristics and notes
1/27/2005	K	Added Die Revision E to ordering information
2/28/2005	L	Edit Ordering Information
3/18/2005	M	Edit Features
08/12/05	N	Edit Features Edit Pin Functions Edit Reliability Characteristics Edit D.C. Operating Characteristics Edit A.C. Characteristics Add Package Dimensions Edit Ordering Information

---

### Copyrights, Trademarks and Patents

Trademarks and registered trademarks of Catalyst Semiconductor include each of the following:

DPP™ AE<sup>2</sup>™

Catalyst Semiconductor has been issued U.S. and foreign patents and has patent applications pending that protect its products. For a complete list of patents issued to Catalyst Semiconductor contact the Company's corporate office at 408.542.1000.

*CATALYST SEMICONDUCTOR MAKES NO WARRANTY, REPRESENTATION OR GUARANTEE, EXPRESS OR IMPLIED, REGARDING THE SUITABILITY OF ITS PRODUCTS FOR ANY PARTICULAR PURPOSE, NOR THAT THE USE OF ITS PRODUCTS WILL NOT INFRINGE ITS INTELLECTUAL PROPERTY RIGHTS OR THE RIGHTS OF THIRD PARTIES WITH RESPECT TO ANY PARTICULAR USE OR APPLICATION AND SPECIFICALLY DISCLAIMS ANY AND ALL LIABILITY ARISING OUT OF ANY SUCH USE OR APPLICATION, INCLUDING BUT NOT LIMITED TO, CONSEQUENTIAL OR INCIDENTAL DAMAGES.*

Catalyst Semiconductor products are not designed, intended, or authorized for use as components in systems intended for surgical implant into the body, or other applications intended to support or sustain life, or for any other application in which the failure of the Catalyst Semiconductor product could create a situation where personal injury or death may occur.

Catalyst Semiconductor reserves the right to make changes to or discontinue any product or service described herein without notice. Products with data sheets labeled "Advance Information" or "Preliminary" and other products described herein may not be in production or offered for sale.

Catalyst Semiconductor advises customers to obtain the current version of the relevant product information before placing orders. Circuit diagrams illustrate typical semiconductor applications and may not be complete.

---



Catalyst Semiconductor, Inc.

Corporate Headquarters

1250 Borregas Avenue

Sunnyvale, CA 94089

Phone: 408.542.1000

Fax: 408.542.1200

[www.caalyst-semiconductor.com](http://www.caalyst-semiconductor.com)

Publication #: 1022

Revision: N

Issue date: 08/12/05