

HD74LS669

Synchronous Up / Down 4-bit Binary Counter

REJ03D0493-0200
Rev.2.00
Feb.18.2005

This synchronous preset table 4-bit binary counter features an internal carry look-ahead for cascading in high-speed counting applications. Synchronous operation is provided by having all flip-flops clocked simultaneously so that the outputs change coincident with each other when so instructed by the count-enable inputs and internal gating. This mode of operation helps eliminate the output counting spikes that are normally associated with asynchronous (ripple-clock) counters. A buffered clock input trigger the four master-slave flip-flops on the rising (positive-going) edge of the clock waveform. This counter is fully programmable; that is, the outputs may each be preset to either level. the load input circuitry allows loading with the carry-enable output of cascaded counters. As loading is synchronous, setting up a low level at the load input disables the counter and causes the outputs to agree with the data inputs after the next clock pulse. The carry look-ahead circuitry provides for cascading counters for n-bit synchronous applications without additional gating. Instrumental in accomplishing this function are two count enable inputs and a carry output. Both count enable inputs (\bar{P} and \bar{T}) must be low to count. The direction of the count is determined by the level of the up / down input. when the input is high, the counter counts up; when low, it counts down. Input \bar{T} is fed forward to enable the carry output. The carry output thus enabled will produce a low-level output pulse with a duration approximately equal to the high portion of the Q_A output when counting up and approximately equal to the low portion of the Q_A output when counting down. This low level overflow carry pulse can be used to enable successive cascaded stages.

Transitions at the enable \bar{P} or \bar{T} inputs are allowed regardless of the level of the clock input. All inputs are diode-clamped to minimize transmission-line effects, thereby simplifying system design. This counter features a fully independent clock circuit. Changes at control inputs (enable \bar{P} , enable \bar{T} , load, up / down) that will modify the operating mode have no effect until clocking occurs. The function of the counter (whether enabled, disabled, loading, or counting) will be dictated solely by the conditions meeting the stable setup and hold times.

Features

- Ordering Information

Part Name	Package Type	Package Code (Previous Code)	Package Abbreviation	Taping Abbreviation (Quantity)
HD74LS669FPEL	SOP-16 pin (JEITA)	PRSP0016DH-B (FP-16DAV)	FP	EL (2,000 pcs/reel)

Note: Please consult the sales office for the above package availability.

Pin Arrangement

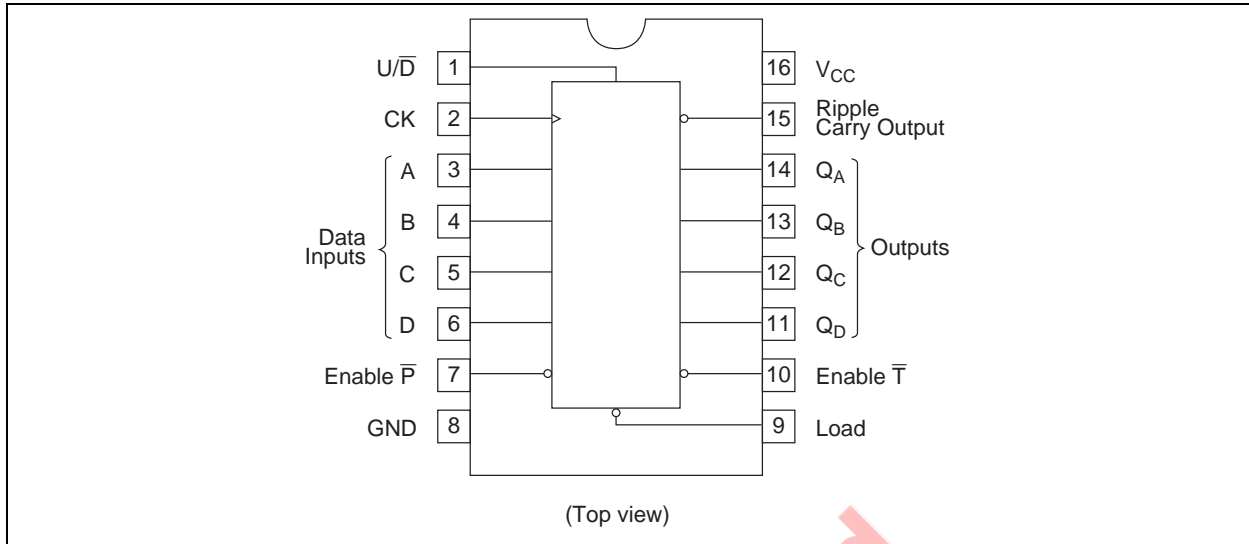

Block Diagram

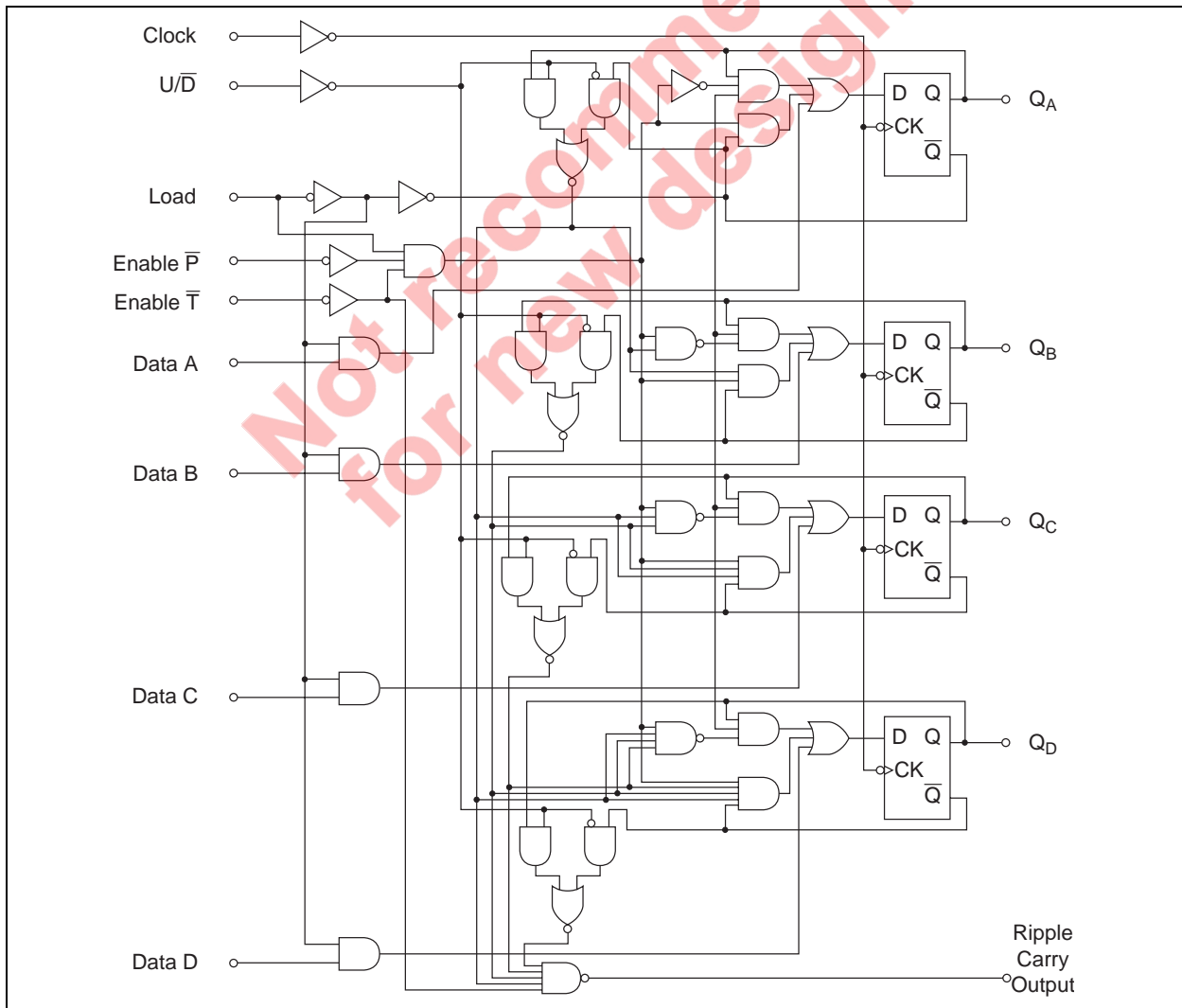

Absolute Maximum Ratings

Item	Symbol	Ratings	Unit
Supply voltage	V_{CC}	7	V
Input voltage	V_{IN}	7	V
Power dissipation	P_T	400	mW
Storage temperature	T_{stg}	-65 to +150	°C

Note: Voltage value, unless otherwise noted, are with respect to network ground terminal.

Recommended Operating Conditions

Item	Symbol	Min	Typ	Max	Unit	
Supply voltage	V_{CC}	4.75	5.00	5.25	V	
Output current	I_{OH}	—	—	-400	μ A	
	I_{OL}	—	—	8	mA	
Operating temperature	T_{opr}	-20	25	75	°C	
Count frequency	f_{count}	0	—	25	MHz	
Clock pulse width	$t_w (CK)$	25	—	—	ns	
Setup time	Input Data A, B, C, D	t_{su}	25	—	—	ns
	Enable \bar{P} , \bar{T}		35	—	—	
	Load		30	—	—	
	Up/Down		35	—	—	
Hold time	t_h	0	—	—	ns	

Electrical Characteristics

($T_a = -20$ to $+75$ °C)

Item	Symbol	min.	typ.*	max.	Unit	Condition	
Input voltage	V_{IH}	2.0	—	—	V		
	V_{IL}	—	—	0.8	V		
Output voltage	V_{OH}	2.7	—	—	V	$V_{CC} = 4.75$ V, $V_{IH} = 2$ V, $V_{IL} = 0.8$ V, $I_{OH} = -400$ μ A	
	V_{OL}	—	—	0.4	V	$I_{OL} = 4$ mA	
—		—	0.5	V	$I_{OL} = 8$ mA	$V_{CC} = 4.75$ V, $V_{IH} = 2$ V, $V_{IL} = 0.8$ V	
Input current	A, B, C, D, \bar{P} , U/\bar{D}	I_{IH}	—	—	20	μ A	$V_{CC} = 5.25$ V, $V_I = 2.7$ V
	Clock, \bar{T}		—	—	20		
	Load		—	—	40		
	A, B, C, D, \bar{P} , U/\bar{D}	I_{IL}	—	—	-0.4	mA	$V_{CC} = 5.25$ V, $V_I = 0.4$ V
	Clock, \bar{T}		—	—	-0.4		
	Load		—	—	-0.8		
A, B, C, D, \bar{P} , U/\bar{D}	I_I	—	—	0.1	mA	$V_{CC} = 5.25$ V, $V_I = 7$ V	
Clock, \bar{T}		—	—	0.1			
Load		—	—	0.2			
Short-circuit output current	I_{OS}	-20	—	-100	mA	$V_{CC} = 5.25$ V	
Supply current**	I_{CC}	—	20	34	mA	$V_{CC} = 5.25$ V	
Input clamp voltage	V_{IK}	—	—	-1.5	V	$V_{CC} = 4.75$ V, $I_{IN} = -18$ mA	

Notes: * $V_{CC} = 5$ V, $T_a = 25$ °C

** I_{CC} is measured after applying a momentary 4.5 V, then ground, to clock input with all other inputs grounded the outputs open.

Switching Characteristics

($V_{CC} = 5\text{ V}$, $T_a = 25^\circ\text{C}$)

Item	Symbol	Inputs	Outputs	min.	typ.	max.	Unit	Condition
Maximum clock frequency	f_{max}			25	32	—	MHz	
Propagation delay time	t_{PLH}	Clock	Ripple Carry	—	26	40	ns	$C_L = 15\text{ pF}$, $R_L = 2\text{ k}\Omega$
	t_{PHL}			—	40	60		
	t_{PLH}	Clock	Q_A to Q_D	—	18	27	ns	
	t_{PHL}			—	18	27		
	t_{PLH}	Enable \bar{T}	Ripple Carry	—	11	17	ns	
	t_{PHL}			—	29	45		
	t_{PLH}	Up/Down	Ripple Carry	—	22	35	ns	
	t_{PHL}			—	26	40		

Count Sequence

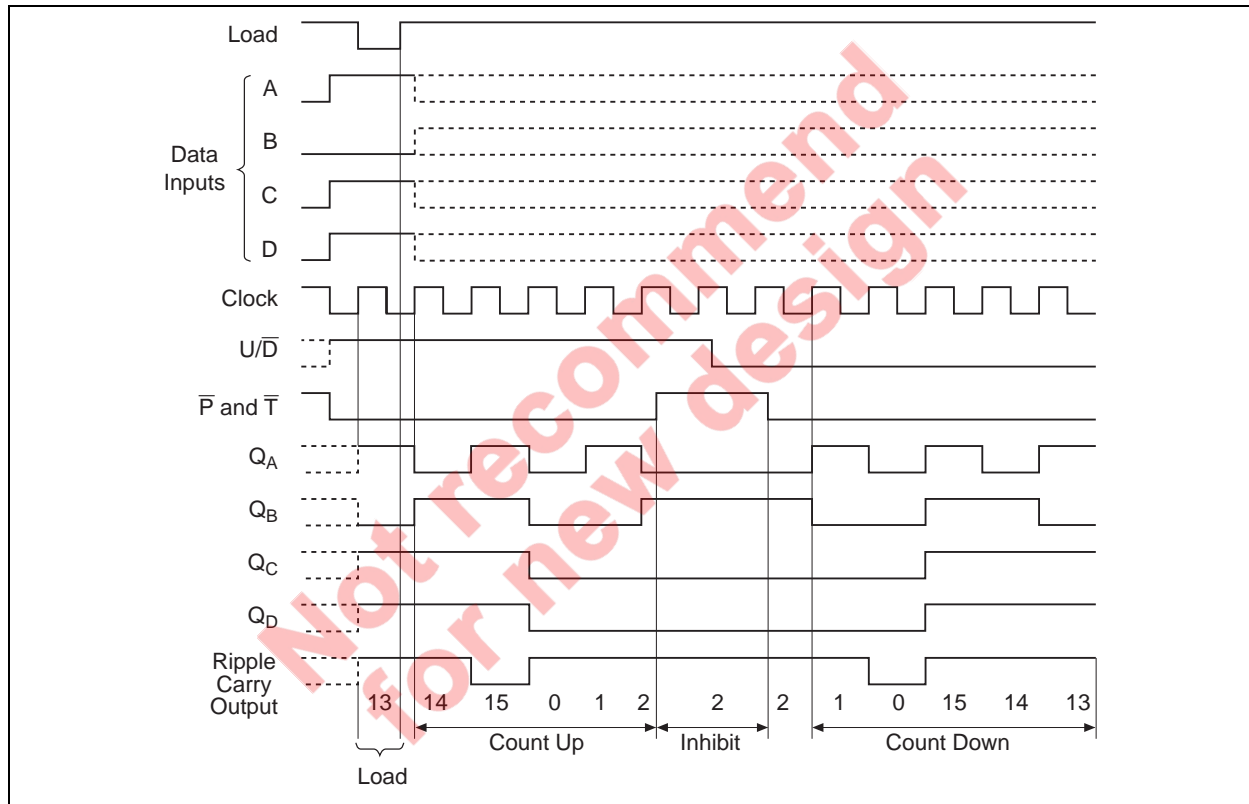

Testing Method

Test Circuit

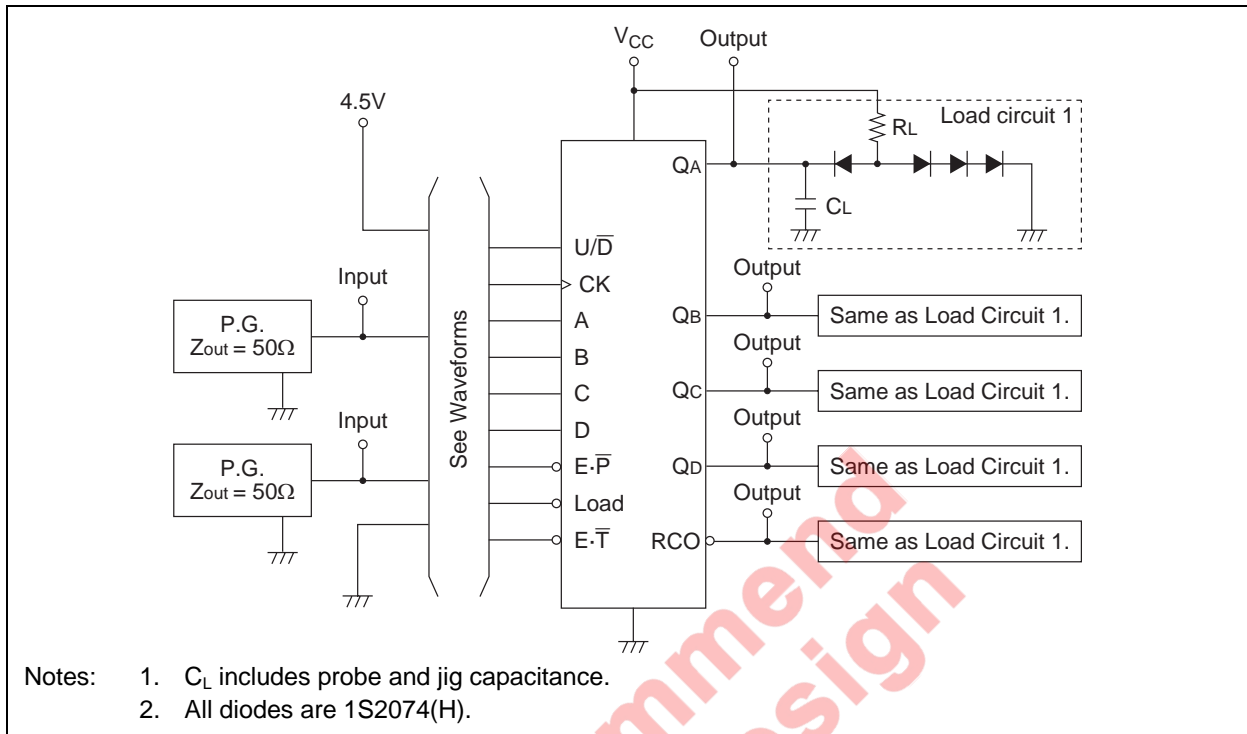

Waveforms 1

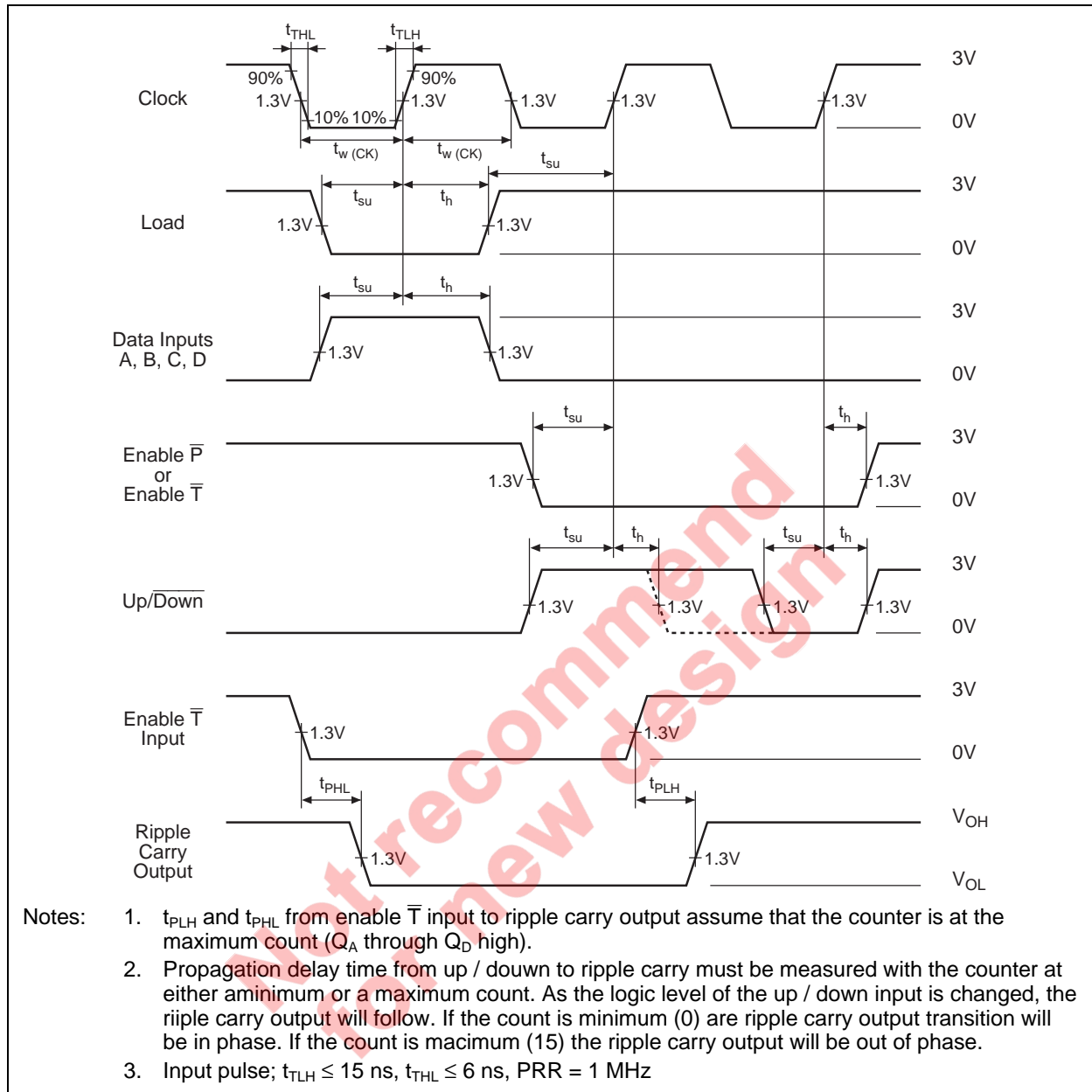

Waveforms 2

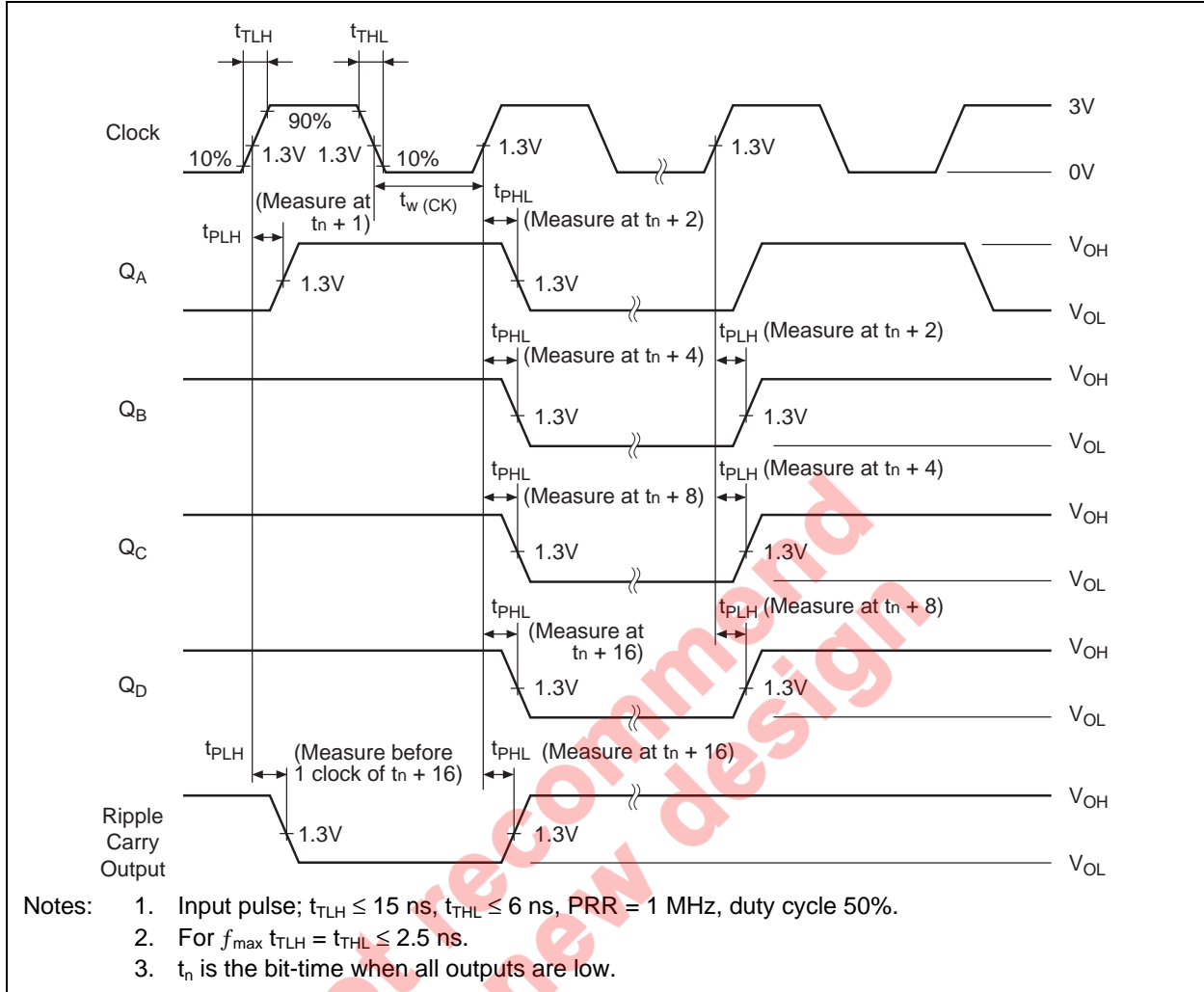

Package Dimensions

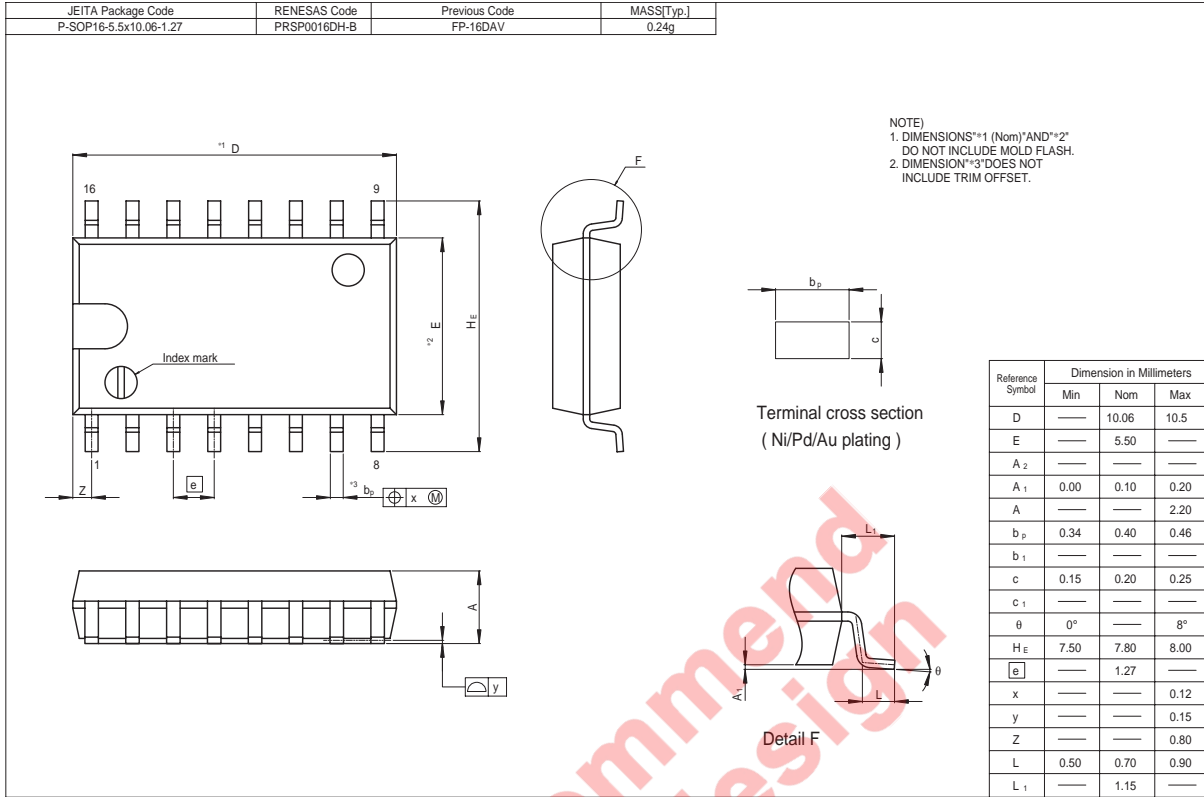

Not recommended for new design

Renesas Technology Corp. Sales Strategic Planning Div. Nippon Bldg., 2-6-2, Ohte-machi, Chiyoda-ku, Tokyo 100-0004, Japan

Keep safety first in your circuit designs!

1. Renesas Technology Corp. puts the maximum effort into making semiconductor products better and more reliable, but there is always the possibility that trouble may occur with them. Trouble with semiconductors may lead to personal injury, fire or property damage. Remember to give due consideration to safety when making your circuit designs, with appropriate measures such as (i) placement of substitutive, auxiliary circuits, (ii) use of nonflammable material or (iii) prevention against any malfunction or mishap.

Notes regarding these materials

1. These materials are intended as a reference to assist our customers in the selection of the Renesas Technology Corp. product best suited to the customer's application; they do not convey any license under any intellectual property rights, or any other rights, belonging to Renesas Technology Corp. or a third party.
2. Renesas Technology Corp. assumes no responsibility for any damage, or infringement of any third-party's rights, originating in the use of any product data, diagrams, charts, programs, algorithms, or circuit application examples contained in these materials.
3. All information contained in these materials, including product data, diagrams, charts, programs and algorithms represents information on products at the time of publication of these materials, and are subject to change by Renesas Technology Corp. without notice due to product improvements or other reasons. It is therefore recommended that customers contact Renesas Technology Corp. or an authorized Renesas Technology Corp. product distributor for the latest product information before purchasing a product listed herein. The information described here may contain technical inaccuracies or typographical errors. Renesas Technology Corp. assumes no responsibility for any damage, liability, or other loss rising from these inaccuracies or errors. Please also pay attention to information published by Renesas Technology Corp. by various means, including the Renesas Technology Corp. Semiconductor home page (<http://www.renesas.com>).
4. When using any or all of the information contained in these materials, including product data, diagrams, charts, programs, and algorithms, please be sure to evaluate all information as a total system before making a final decision on the applicability of the information and products. Renesas Technology Corp. assumes no responsibility for any damage, liability or other loss resulting from the information contained herein.
5. Renesas Technology Corp. semiconductors are not designed or manufactured for use in a device or system that is used under circumstances in which human life is potentially at stake. Please contact Renesas Technology Corp. or an authorized Renesas Technology Corp. product distributor when considering the use of a product contained herein for any specific purposes, such as apparatus or systems for transportation, vehicular, medical, aerospace, nuclear, or undersea repeater use.
6. The prior written approval of Renesas Technology Corp. is necessary to reprint or reproduce in whole or in part these materials.
7. If these products or technologies are subject to the Japanese export control restrictions, they must be exported under a license from the Japanese government and cannot be imported into a country other than the approved destination. Any diversion or reexport contrary to the export control laws and regulations of Japan and/or the country of destination is prohibited.
8. Please contact Renesas Technology Corp. for further details on these materials or the products contained therein.



RENESAS SALES OFFICES

<http://www.renesas.com>

Refer to "<http://www.renesas.com/en/network>" for the latest and detailed information.

Renesas Technology America, Inc.

450 Holger Way, San Jose, CA 95134-1368, U.S.A
Tel: <1> (408) 382-7500, Fax: <1> (408) 382-7501

Renesas Technology Europe Limited

Dukes Meadow, Millboard Road, Bourne End, Buckinghamshire, SL8 5FH, U.K.
Tel: <44> (1628) 585-100, Fax: <44> (1628) 585-900

Renesas Technology Hong Kong Ltd.

7th Floor, North Tower, World Finance Centre, Harbour City, 1 Canton Road, Tsimshatsui, Kowloon, Hong Kong
Tel: <852> 2265-6688, Fax: <852> 2730-6071

Renesas Technology Taiwan Co., Ltd.

10th Floor, No.99, Fushing North Road, Taipei, Taiwan
Tel: <886> (2) 2715-2888, Fax: <886> (2) 2713-2999

Renesas Technology (Shanghai) Co., Ltd.

Unit2607 Ruijing Building, No.205 Maoming Road (S), Shanghai 200020, China
Tel: <86> (21) 6472-1001, Fax: <86> (21) 6415-2952

Renesas Technology Singapore Pte. Ltd.

1 Harbour Front Avenue, #06-10, Keppel Bay Tower, Singapore 098632
Tel: <65> 6213-0200, Fax: <65> 6278-8001